



The University of  
**Nottingham**

UNITED KINGDOM • CHINA • MALAYSIA

Kolluru, Kiran V. and Axinte, Dragos A. and Raffles, Mark H. and Becker, Adib A. (2014) Vibration suppression and coupled interaction study in milling of thin wall casings in the presence of tuned mass dampers. Proceedings of the Institution of Mechanical Engineers, Part B: Journal of Engineering Manufacture, 228 (6). pp. 826-936. ISSN 2041-2975

**Access from the University of Nottingham repository:**

<http://eprints.nottingham.ac.uk/35508/1/%28ePrint%20Version%29-2014-Kolluru-Vibration%20suppression-%28Published%29.pdf>

**Copyright and reuse:**

The Nottingham ePrints service makes this work by researchers of the University of Nottingham available open access under the following conditions.

This article is made available under the University of Nottingham End User licence and may be reused according to the conditions of the licence. For more details see: [http://eprints.nottingham.ac.uk/end\\_user\\_agreement.pdf](http://eprints.nottingham.ac.uk/end_user_agreement.pdf)

**A note on versions:**

The version presented here may differ from the published version or from the version of record. If you wish to cite this item you are advised to consult the publisher's version. Please see the repository url above for details on accessing the published version and note that access may require a subscription.

For more information, please contact [eprints@nottingham.ac.uk](mailto:eprints@nottingham.ac.uk)

Kolluru, K.V., Axinte, D.A., Raffles, M.H., Becker, A.A. “Vibration suppression and coupled interaction study in milling of thin wall casings in the presence of tuned mass dampers”, **Proc. IMechE, Part B: Journal of Engineering Manufacture**, Vol. 228 (6), pp. 826-836, 2014.

## **Vibration suppression in machining of thin wall casings through tuned mass dampers – A finite element analysis approach**

K Kolluru<sup>a</sup>, D Axinte<sup>a,\*</sup>, M Raffles<sup>a</sup>, AA Becker<sup>a</sup>, B Staples<sup>b</sup>, P Winton<sup>b</sup>

<sup>a</sup> Department of Mechanical, Materials and Manufacturing Engineering, University of Nottingham, Nottingham NG7 2RD, UK

<sup>b</sup> Rolls-Royce plc, Derby DE24 8BJ, UK

### **Abstract**

Damping of machining vibrations in thin walled structures is an important area of research due to the ever-increasing use of lightweight structures such as jet engine casings. Previous work reported in the literature has focussed on passive and active damping solutions for simple planar thin walls; whereas vibration damping in thin wall ring type casings was not reported. Moreover, implementation of any of these solutions on an industrial scale component needs proven simulation tools for validation. In this work, a passive damping solution in the form of tuned viscoelastic dampers is studied to minimise the vibration of thin walled casings. The implementation of tuned dampers was driven by a specific characteristic observed for the casing under study where a couple of modes dominate the dynamic response. Finite element simulation studies are carried out for a casing both with and without passive dampers, and are validated using machining tests and experimental modal tests. The finite element predictions are found to match with experimental results with reasonable accuracy.

### **Keywords**

Thin wall casing, tuned viscoelastic damper, machining vibration, frequency response, finite element analysis

## **1. Introduction**

Machining of thin wall structures is a challenging task owing to their low stiffness. Common problems encountered during the machining of such structures are static deflections of the workpiece and chatter. While static deflection of the workpiece causes out of tolerance geometries, chatter produces geometrical inaccuracies, poor surface finish, tool wear, damage to spindle bearings, and may sometimes lead to scrapping of the part. Researchers have addressed this problem from two different perspectives – choosing stable (chatter-free) machining parameters and proposing fixturing solutions. Selection of stable machining parameters is based upon chatter prediction theories proposed in the literature [1-5]. A machining system consists of Machine-Tool-Workpiece-Fixture

\* Corresponding author at: Department of Mechanical, Materials and Manufacturing Engineering, Room B72 Coates Building, The University of Nottingham, University Park, Nottingham, Nottinghamshire NG7 2RD, UK.

Tel.: +44 0 115 951 4117; fax: +44 0 115 951 3800.

E-mail address: Dragos.Axinte@nottingham.ac.uk (D. Axinte)

chain. Calculation of stable machining parameters must take into account one or more of the weak links of this system. The stability lobe algorithms, available through commercially available software [6, 7], are currently being used mostly for machines, tools, and fixtures and in general are utilised for simple workpiece geometries [8-10]. Workpiece vibration when machining complex components could be more practically addressed through fixturing solutions [11]. This is mainly due to the complexity involved in obtaining a workpiece frequency response and also due to the fact that it changes with removal of material during machining. Hence, the way to suppress vibration is through appropriate fixture designs. Moreover, the research in suppressing vibration through fixturing solutions was not only driven by the need to overcome the complexity of the component's geometry, but also, indirectly, by the use of difficult-to-machine workpiece materials so commonly employed in high value-added products such as gas turbine engines. In these situations, due to process damping effects, the stability lobe algorithms are not particularly useful at the low cutting speeds at which these materials are machined [12].

Typical fixturing solutions researched for improving thin wall machining stability are either standard mechanical fixtures or damping solutions. Research has been carried out in both passive and active damping treatments with a view to suppressing vibrations during machining. However, these solutions have sought to dampen vibrations in toolholders (boring, turning) [13-15] and machine tool structures [16]; only a few researchers have investigated solutions to dampen vibrations arising from the workpiece.

Sims et al. [17] reported mitigation of workpiece chatter during milling using granular particle dampers to provide energy dissipation through friction. Using this technique the depth of cut was able to exceed the previous limit by an order of magnitude. Zhang et al. [18] reported on workpiece chatter avoidance in milling using piezoelectric active damping mounted directly on the workpiece. Although this is more difficult to implement in real industrial environments, by using this approach a seven-fold improvement in the limiting depth of cut has been obtained. However, this has been done on simple geometry parts such as a cantilever plate. Rashid et al [19] proposed an active control of workpiece vibrations in milling through piezo-actuators embedded in work holding systems. However, the part on which the demonstration was done was of simple geometry (rectangular blocks) and was dynamically stiff. Nevertheless, this was directed to improve the dynamics of a production workholding system, (i.e. a pallet) by generating a secondary controlled

signal (i.e. vibration) that cancels the primary disturbing signal generated by the cutting process (i.e. milling); improvements in surface finish and tool life were reported.

In addition to damping through piezo-actuators, passive dampers such as tuned mass dampers were also employed to mitigate workpiece vibration. Rashid et al. [20] proposed the use of tuned mass dampers mounted on a stiff workpiece, a rigid steel block. They presented an experimental validation of tuned viscoelastic dampers for damping a targeted mode of a solid workpiece during a milling operation, in which a reduction in vibration acceleration by 20dB for the targeted mode was reported. The vibration absorbers for structural dynamics applications are usually tuned based on Den Hartog's method which gives two peaks of equal magnitude in the damped frequency response function. However, considering the special nature of machining chatter problems, where the limiting depth of cut in machining is inversely proportional to the negative real part of the transfer function, Sims [21] proposed a novel tuning methodology for vibration absorbers in machining application. This consisted of a tuning methodology with equal troughs of the real part of frequency response function instead of the conventional equal-peaks of amplitude method.

The aforementioned research validates both the passive and active damping concepts on simple geometries which can be represented by a few degrees of freedom. Hence, the solutions that were proposed up to now can be analytically designed and evaluated. However, on actual industrial applications which have a much more complex response with multiple modes, no work has been reported to demonstrate these solutions. Of course, in such situations there is a significant difficulty in simultaneously suppressing various modes that also might change their values while the workpiece is machined. Also, the clamping setups/forces may have some inherent variations.

Moreover, damping of machining vibrations of thin walled cylindrical structures has not been reported. Chang et al [22] studied the chatter behaviour of a thin wall cylindrical workpiece while turning, in which they showed that the chatter phenomenon is determined by the ratio of the internal diameter of the casing to the wall thickness. With an increase in this ratio, the compliance of shell mode increases and hence is easily excited when compared to beam mode. Lai et al [23] studied the stability characteristics while turning a thin walled cylindrical workpiece clamped by a three jaw chuck. They reported that the vibration properties such as stiffness coefficient and vibration direction angle of beam and shell modes change with the relative position of the cutting tool to the chucking jaw. Mehdi et al [24-25] also studied the dynamic behaviour of three jaw clamped thin walled cylindrical workpieces during turning and a proposed response to a Dirac excitation in the form of Nyquist curves to characterise the stability of the turning process – a negative real abscissa value less than -1 indicating an unstable process. They also reported a

reduction in vibrations when a supplementary damper, an arbitrarily selected rubber tube, was attached to the workpiece system. However, there was no mention of the scientific basis of damper selection and also no attempt was made to validate the experimental results using numerical simulations. Also the variation in the dynamic behaviour of the workpiece with added supplementary damping was not presented.

In this context, there exists a clear gap in the literature in two areas: (1) establishing appropriate methodologies for simulating the fixturing setups with vibration damping solutions, and (2) studying of effect of damping treatments on thin walled cylindrical workpieces in milling operations. To the authors' knowledge, no prior work was reported on simulating passive or active damping treatments as fixturing solutions for thin walled components in milling operation, and investigating the effect of the damper on the dynamic response of the components.

To address this need, in this work a finite element simulation was carried out to design and validate the tuned viscoelastic dampers for a thin walled cylindrical component during milling operations, and also to study the behaviour of the workpiece with dampers mounted on it. The advantage of such a simulation is the ability to evaluate the effectiveness of the dampers on actual components during setting up of the fixture, so that vibration during milling is effectively suppressed. Using the proposed simulation methodology, design parameters such as the number and location of the dampers as well as the mass ratio can also be optimised. In this paper, firstly, the dynamic response analysis of the un-damped workpiece (both through finite element and experiment) is discussed. Then, the following sections present the details of the design of the Tuned Viscoelastic Dampers (TVDs) based on the analysis of un-damped workpiece response supported by numerical and experimental validation of TVDs.

## **2. Dynamic response analysis of an un-damped workpiece**

### **2.1. Finite element analysis**

An understanding of the dynamic response of the workpiece is essential before designing the tuned dampers. This section presents numerical and experimental evaluations of the workpiece response. The workpiece chosen was a generic component to represent a practical range of thin walled casings typically used in aerospace structures. The component is made of a Nickel based superalloy (Waspaloy®) and has a thin wall of 2.5mm thickness, a height of 95 mm, and an inner diameter of 360mm. As per industrial specifications, a peripheral milling operation needs to be performed on the thin wall to generate specific features (pockets/bosses). As shown in Figure 1(a), the casing is clamped on a base plate (the fixture) with bolts; here M6 bolts are used as examples.

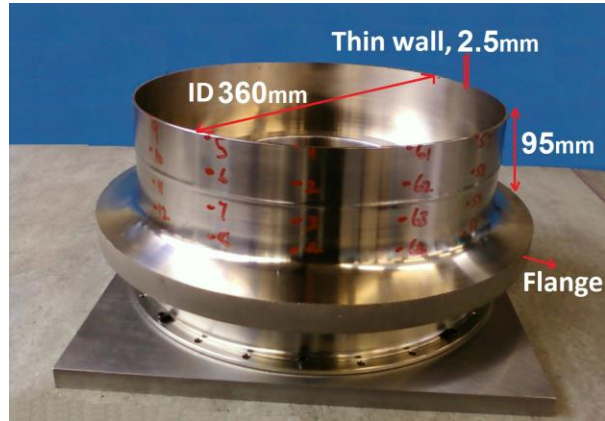

(a)



(b)

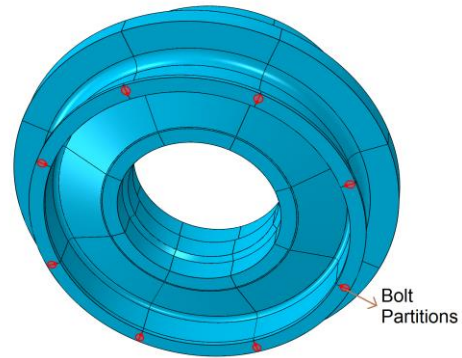

(c)

Figure 1. Casing used for studying viscoelastic damping

(a) Casing geometry (b) Finite element model (c) bottom view of casing showing partitions used as bolt surfaces which are tied to the fixture plate

Finite element analysis was carried out using standard commercial software Abaqus<sup>®</sup>. The casing is meshed using a combination of hexahedral with reduced integration (C3D20R) and tetrahedral (C3D10M) elements to avoid phenomena such as shear and volumetric locking. This combination of elements in the mesh is necessary due to the creation of circular partitions, equal to the bolt sizes, as shown in Figure 1(c) on the bottom flange of the casing. These partitions are fixed to the fixture plate through a 'tie' constraint to simulate a bolted joint. The fixture is meshed using C3D20R elements. The mesh size is finalised based on convergence studies of natural frequencies below 6000Hz, considering the need for studying high frequency modes as explained in the following paragraphs. As most of the modes observed are circumferential modes of the thin shell of the casing, the number of elements on the casing periphery is chosen as the parameter used to achieve

mesh refinement, which provides a direct indication of the highest possible mode that can be captured. Four different mesh sizes are studied: 96, 160, 200 and 240 elements along the casing periphery; and the mesh size that gives similar natural frequencies over successive mesh refinements is chosen. Another criterion which is considered is the representation of the highest frequency mode with reasonable spatial accuracy; ensuring at least 4 to 5 elements exist in half the circumferential wave at the highest frequency of interest. Due to the significant number of modes within this range, the results of only the first three modes and two of the important modes (as explained in subsequent sections) are presented here in Table 1. It can be seen that a mesh refinement of 200 elements along the periphery is capable of representing all modes with sufficient accuracy.

	<b>Number of elements along casing periphery</b>			
<b>Mode no.*</b>	<b>96</b>	<b>160</b>	<b>200</b>	<b>240</b>
1	1287.5	1289.7	1290	1290.2
2	1332.5	1334.3	1334.7	1334.7
3	1384	1386.5	1387	1387
45	4615.8	4617.2	4618.3	4618
46	4722.3	4723.8	4724.7	4724.4
* Excluding symmetric modes				

Table 1. Variation of natural frequencies with mesh refinement

A frequency extraction step was carried out in Abaqus® to extract the first 200 modes using the Lanczos solver as it has the most general capabilities such as computation of modal damping factors and modal participation factors [26]. This high number of modes was chosen considering the fact that most of the modes have symmetric counterparts. Generally, for most of the structures the criteria to decide the number of modes to be extracted depends on the total effective mass in each direction; as this should represent a significant fraction, e.g. 85% [27], of the total mass of the structure. However, for casings such as the one presented here, it is not practical to decide the number of modes based on such criteria due to the fact that part of the structure (the thin wall) has very low stiffness when compared to the remaining part (e.g. the flange). For example, the total

casing weights 80 kg and the thin wall section amounts to only 4 kg. Due to this reason, most of the modes extracted are local modes of the thin wall and the effective mass in each direction accounts for only 70% of the total structural mass even after the extraction of 500 modes (highest frequency corresponding to 20,000 Hz).

Harmonic analysis was carried out to study the workpiece response at all the extracted natural frequencies in which the casing thin wall participates. The harmonic response was computed using a linear perturbation step in Abaqus®, steady state dynamics, and direct integration. Although this step is computationally expensive, it was chosen as it gives accurate results in the presence of material properties that depend on frequency – a characteristic of viscoelastic materials, the analysis of which is presented in the next section. To maintain a direct comparison between damped and un-damped casings, the same analysis step was chosen for the un-damped casing. As the amplitude of the harmonic response of the un-damped casing will be unrealistically high, a preliminary experimental modal analysis was carried out to find out the order of structural damping. This was found to be of the order of 0.1% after curve-fitting the frequency responses. The same damping factor was input for the finite element simulations. The harmonic response of the un-damped casing, as shown in Figure 2, is computed using fifteen frequency points, around each resonance peak, with frequency spacing of 0.2Hz. Such close frequency spacing was chosen to capture the resonance peak considering the un-damped nature of the frequency response. However, considering the high computational cost associated with using direct integration, the number of points is kept to a minimum, and hence the discrete nature of the spectrum in Figure 2.

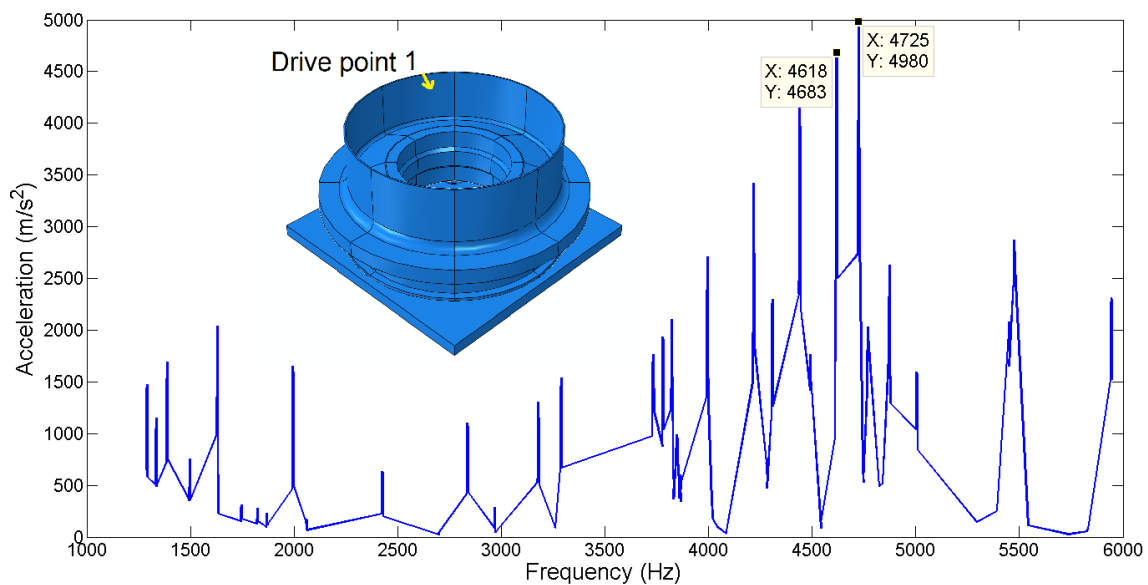
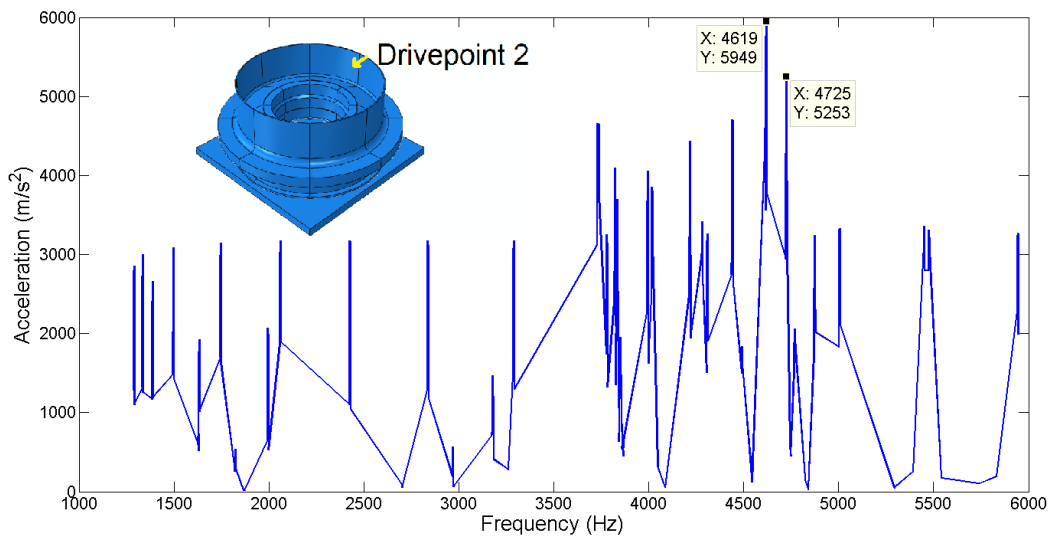

Figure 2. Driving point harmonic response of un-damped casing [Inset: response location on casing]



For a clamped with a three jaw chuck, Lai et al [23] reported that for thin wall casings different modes get excited as the position of the tool changes with respect to the jaw location. However, in the present case the bottom of the thin wall can be considered to be uniformly clamped all around the circumference due to the rigid hub and flange at the bottom. To study the effect of this the drive point, harmonic response was acquired at different locations on the circumference of the thin wall of the casing as shown in Figure 3. As seen in the harmonic responses shown in Figure 3, in all the cases a dominant response is noticed for modes 4724.7 Hz and 4618.3 Hz; these modes correspond to the 1<sup>st</sup> and 2<sup>nd</sup> circumferential nodal orders ( $n=1$  and  $2$ , where  $n$  is the number of circumferential waves) with one nodal point in the axial direction ( $m=2$ , where  $m-1$  is the number of nodes in the axial direction), as shown in Figure 4. Symmetric modes at 90 degrees were also observed for the same shapes.



(a)

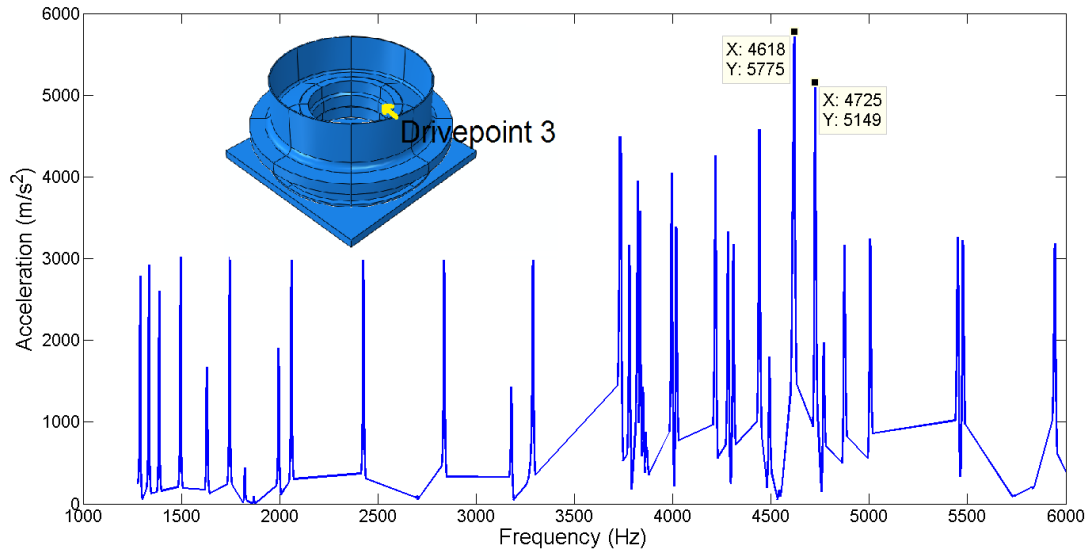

(b)

Figure 3. Harmonic response on un-damped casing at additional points (a) ... (b) ...

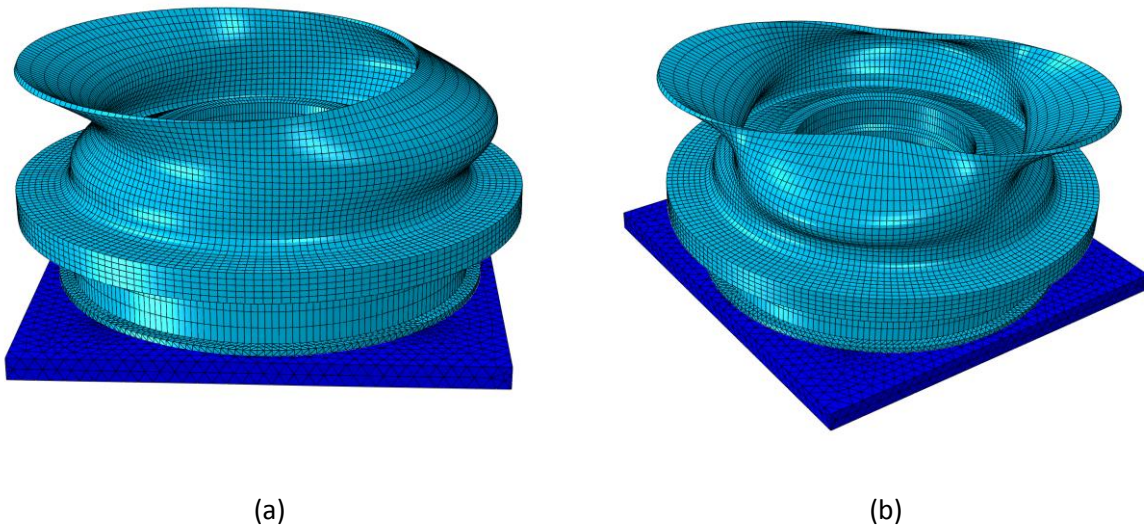

Figure 4. Mode shapes of two dominant modes (a) 4724.7 Hz, (b) 4618.3 Hz

## 2.2. Machining experiments on un-damped casing

To study the behaviour of the dominance of a group of modes in the dynamic response as observed in FE analysis, machining trials were carried out on the casing with two accelerometers mounted on it within the machining zone. Peripheral milling cuts were taken over one full quarter of the casing using a  $\varnothing 16\text{mm}$  tool with two inserts. An axial and radial depths of cut of 2mm and 1mm along with a feed rate of 0.1mm/tooth and cutting speed of 40 m/min are employed. The frequency spectrum (FFT) of the machining acceleration signal was studied at various instances of the entire machining

sequence. Figure 5 shows one such analysis of frequency spectra for a time period of one tooth contact, which can be considered to be an impact excitation of the structure. Note that Figure 5 shows the acceleration signal for one complete revolution of the tool having 2 inserts. It can be seen that 4869Hz and 4767Hz and their harmonics are quite dominant in the whole spectrum. In fact, this behaviour was observed, within a variation of only a few Hz, without fail in the whole acceleration signal acquired over a machining period for a quarter part of the casing.

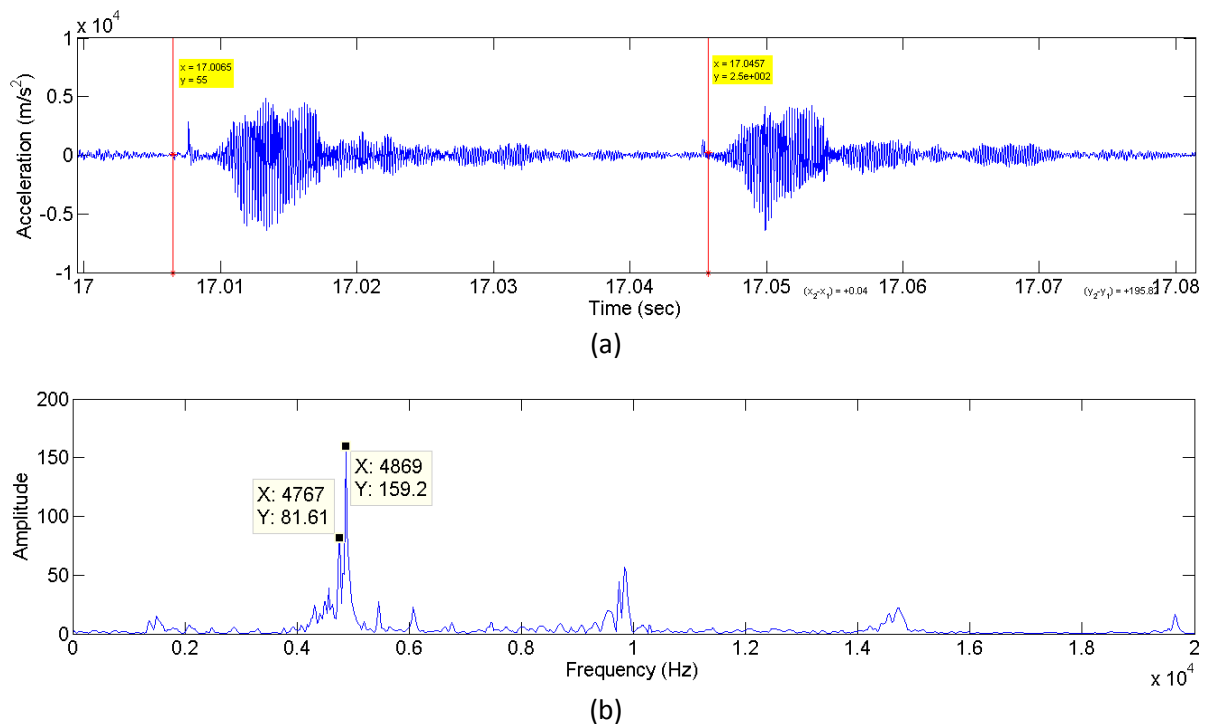

Figure 5. (a) Acceleration signal acquired during machining (b) frequency spectrum

### 2.3. Modal testing of un-damped casing

The variation between the finite element prediction of 4724.7Hz and the experimental observation of 4869Hz in frequency spectra of the machining signal is analysed. Experimental modal analysis was carried out on the casing in the actual machining set up, as shown in Figure 6, considering the sensitivity of modes to the boundary conditions. As the thin walled section of the casing is of primary interest, the test was carried out only on this area. The grid size for modal testing was decided after studying the mode shapes in the finite element analysis. As the height of the thin wall of the casing is small when compared to the diameter, it has a relatively easier tendency to vibrate at higher order circumferential modes as compared to axial direction. This can be observed from the fact that within the studied frequency band (0-6000 Hz) seventeen circumferential and second axial modal orders are noticed. Hence the thin wall was meshed into 36 sections circumferentially and 4 sections axially. Considering that such a symmetrical structure has repeating modes, two reference accelerometers

are used to capture the symmetric modes. The mode shape analysis revealed that the  $m=2$  and  $n=1$  mode (terminology as explained in section 2.1) occurs at 4874.7Hz as shown in Figure 7, the mode shape of which compares with that of the FE mode 4724.7Hz, see Figure 4(a), and thus confirming the FE prediction. Similarly,  $m=2$  and  $n=2$  mode occurs at 4760.41Hz which corresponds to the FE mode of 4618.3Hz. The slight mismatch in frequencies could be due to non-updating of the finite element model. A finite element model with bolted joints modelled using spring dashpot elements, as reported in [28] and updating their stiffness and damping using experimental results will predict the correct natural frequencies; however in the present study this error of 3% is considered acceptable for further analysis.

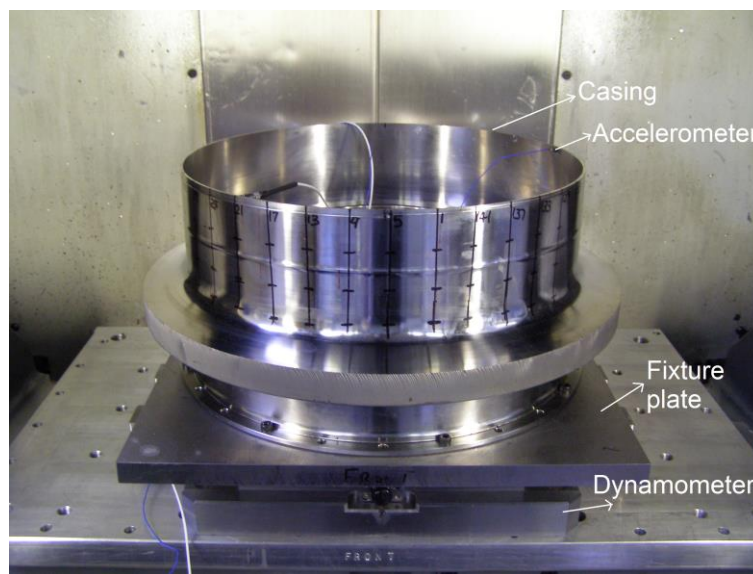

Figure 6. Casing clamped onto fixture and dynamometer for experimental modal analysis

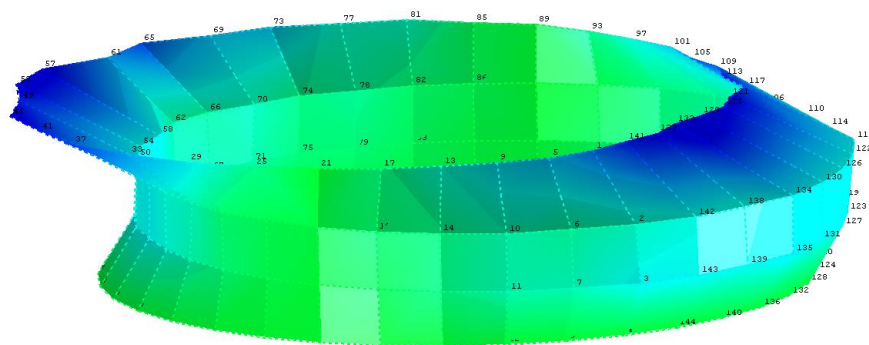

Figure 7. Experimental mode shape at 4874.7Hz ( $m=2, n=1$ ) mode

Considering the finite element and experimental results, it can be seen that the first and second order circumferential modes are dominant for the given boundary conditions. The FE model predicts the dominant modes, through harmonic analysis, with reasonable accuracy. It is also shown that the generalised modal mass obtained during the extraction of the natural frequencies can be used as an indicator for possible dominant modes. The fact that few modes are dominant irrespective of the location of excitation along the circumference, has offered the scope to try out tuned dampers as the possible damping solution. The next section presents the methodology employed in designing the tuned dampers and the results obtained thereof.

### 3. Dynamic response analysis of workpiece with TVDs

#### 3.1. Finite element modelling of TVDs

Finite element analysis of viscoelastic damping is a popular approach for dealing with constrained layer damping of automotive panel vibrations. Research has been carried out on various aspects such as developing methodologies for the faster prediction of the damped response of structures [29-30], optimisation of damper location [31-32], and development of new damping polymers to suit different automotive components [33-34]. A detailed review of modelling and finite element implementation of viscoelastic damping is given in Vasques et al [35].

A viscoelastic material is represented using a complex modulus in the frequency domain:

$$G^* = G' + iG'' = G'(1 + i\eta) \quad (1)$$

Where  $G'$  and  $G''$  represent storage and loss modulus respectively, and  $\eta = G''/G'$  represents the loss factor of material. Manufacturers' data sheets for the damping polymers generally provide the storage modulus and loss factor in the form of nomographs showing their frequency and temperature dependence. In this research, 3M® ISD112 viscoelastic tape is used as it has a high loss factor and a moderate modulus value, and with a little variation of these values within the expected operational temperature range. The frequency domain viscoelastic data for 3M® ISD112 provided in [36] which was extracted from manufacturer's data sheet is used in this simulation and is reproduced in the Appendix. The guidelines for static and dynamic analysis of viscoelastic materials using finite elements are summarised in [37].

Considering the experimental dynamic response of the un-damped casing as presented in Figure 5(b) and the experimental modal analysis results presented in Figure 7, the 4874.7Hz mode is the most dominant mode throughout the casing. The corresponding FE mode is 4724.7Hz and hence the tuned viscoelastic dampers for FE analysis are designed for 4724.7 Hz. However, for experimental

validation, presented in the next section, dampers were tuned for 4874 Hz. The storage shear modulus and loss factor for this 4724.7Hz frequency are 6.89 MPa and 0.60 respectively, which are obtained through linear interpolation from the frequency domain data provided in Table A-1 in the Appendix. For a given target frequency, the design parameters are the mass of the damper block and the thickness of viscoelastic tape. It is usual to take the damper block mass as 1-5% of the vibrating mass [38], and calculate the corresponding thickness of viscoelastic tape using equations (2) and (3).

$$\omega_n = \sqrt{\frac{k}{m}} \quad (2)$$

$$k = \frac{AE}{l} \quad (3)$$

where  $\omega_n$  = target natural frequency, Hz

$k$  = stiffness, N/m

$m$  = Mass of the damper, kg

$A$  = Area of damper block over which the viscoelastic layer will be attached, m<sup>2</sup>

$l$  = Thickness of viscoelastic tape, m

$E$  = Young's modulus of the viscoelastic material, MPa, obtained from the shear modulus,  $G$  using the relation  $2G(1+\nu)$ ,  $\nu$  being Poisson's ratio (0.49 for the viscoelastic material 3M ISD112)

For the casing under study, the 2.5mm thin wall is considered to be the main vibrating mass (4.47kg). With the above calculations, for a mild steel damper block with a mass equal to 5% of vibrating mass and dimensions of 40x40x20mm, the thickness of viscoelastic tape was found out to be 0.163mm. A finite element model, shown in Figure 8, was created with these parameters in which a single damper block is modelled (attached) inside the periphery of the casing. The location of the damper block is arranged at the maximum amplitude location of 4724.7Hz mode of FE, mode shape as shown in Figure 4(a). Though this mode also has an identical symmetric mode shape at 90 degrees, only one damper block is modelled initially to study the effect of a single damper block. The damper block was meshed using C3D20R elements, similar to the casing, and the viscoelastic layer was meshed using hybrid continuum elements C3D20RH which will give accurate results while simulating incompressible rubber-like materials [37], such as the 3M ISD112 viscoelastic material used in this study. The nodes of the viscoelastic layer are tied to those of the casing and damper block on either side. To minimise the distortion due to the automatic re-adjustment of the nodes by Abaqus® before the analysis, a uniform mesh was designed for the viscoelastic and damper blocks where nodes of these parts fall close to each other. During initial trials, it was noticed that this step is

essential as non-matching nodes can result in distorted elements leading to aborting of the simulation.

After completion of the initial frequency extraction step, a harmonic analysis was run using Steady State Dynamics, Direct step. As explained in the previous section, this allows viscoelastic material properties, which vary with frequency, to be considered, albeit at additional computational burden. It should be noted that while extracting natural frequencies, Abaqus® gives the option of considering the frequency dependent properties at only one frequency point, and in this case 4725Hz was considered for that option as the damper is tuned for this frequency. Also, out of all the frequencies extracted, some of the modes correspond to the rigid body motion of the damper block, viscoelastic layer and the bending modes of the fixture plate without affecting the casing. These frequencies are discarded while evaluating the harmonic response, retaining only those modes where the casing participated.

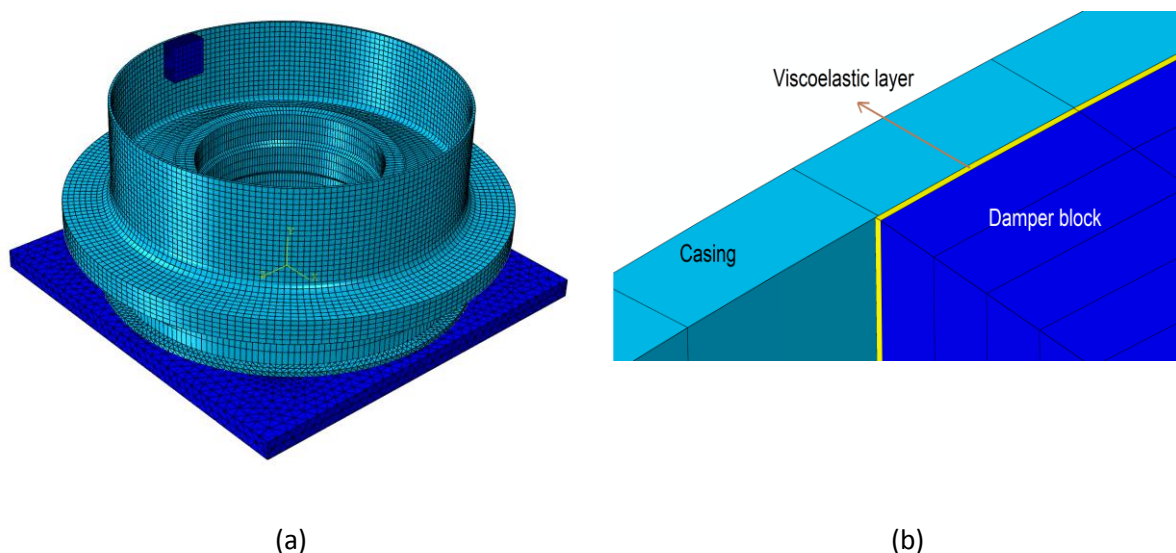

Figure 8. (a) FE model with single TMD (b) Close up view showing the viscoelastic layer between damper block and casing

The drive point harmonic response (Figure 9) clearly shows that the targeted mode of 4725Hz is damped about 7 times, while decreasing the overall response acceleration magnitude. A close analysis of mode shapes with respect to the response reveals that out of the two symmetric modes of 4725Hz, the mode shape which is targeted for damping has shifted to 4707.7Hz with mode shape as shown in Figure 10(a) and the other mode remained at similar frequency of 4725.2Hz with mode shape as shown in Figure 10(b). However, the response magnitude in both the cases has reduced to approximately  $600 \text{ m/s}^2$  from an un-damped response of  $4992 \text{ m/s}^2$  (at the same location as shown



in Figure 2). This not only shows the importance of choosing the placement location of the damper but also its efficacy on damping the targeted mode.

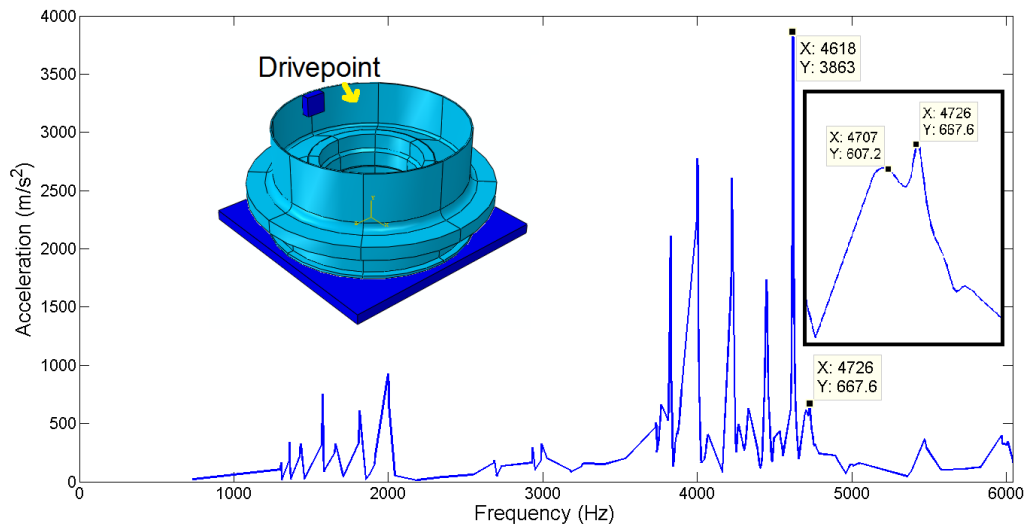

Figure 9. Harmonic response of casing with single TMD; Insets show the location where the response is acquired and the close-up view of the targeted mode

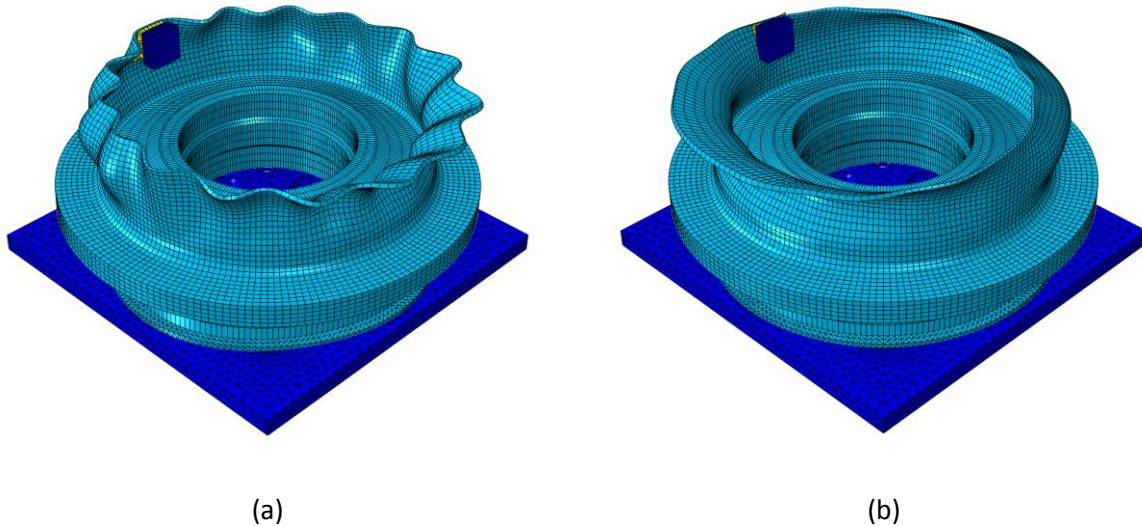
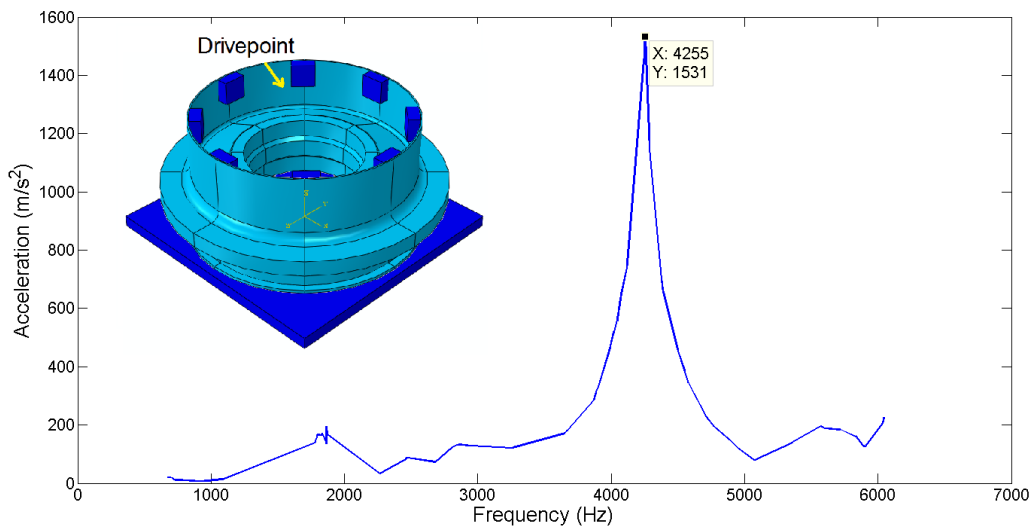

Figure 10. Mode shapes of targeted mode with tuned mass damper in place (a) Targeted mode – 4707.7Hz (b) Symmetric mode – 4725.2Hz

In addition to damping of the targeted mode of 4724.7Hz, the tuned damper has its positive effect on all other modes which can be observed by comparing the amplitude of response in Figure 2 and Figure 9, e.g. the next dominant mode of 4618Hz has its amplitude reduced from 4683 m/s<sup>2</sup> to 3863 m/s<sup>2</sup>. To study this effect when a series of damper blocks are mounted, an analysis was carried out



with 8 damper blocks along the casing periphery, with all the blocks tuned for 4725Hz. This configuration simulates the effect of increased mass percentage of tuned damper; the placement of which covering the whole structure. This configuration, in addition to acting as a tuned damper for a particular frequency, acts as a mass addition with a damping layer on it. Figure 11(a) shows the casing FE model with 8 tuned dampers and its harmonic response with excitation applied as shown in the inset. Figure 11(b) shows the mode shape of the dominant mode 4255Hz. While it is intuitive to think that the casing now vibrates most inbetween two dampers, the presence of such vibration as the only dominant mode is an interesting observation. While there is a dominant mode, it can be observed that the peak acceleration has reduced from 4900 m/s<sup>2</sup> to 1530 m/s<sup>2</sup>, showing an improvement of 3.2 times.



(a)

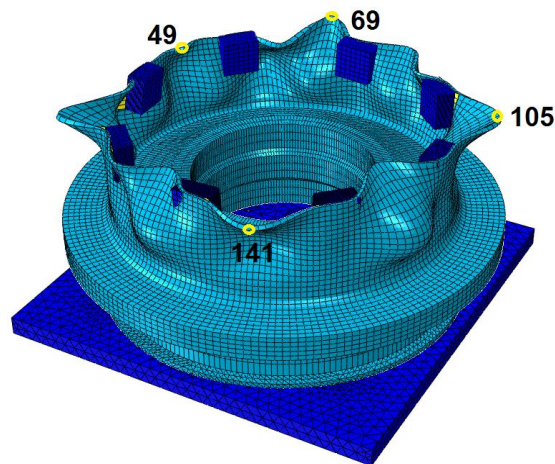

(b)

Figure 11. (a) Harmonic response of casing with 8 tuned dampers (b) Mode shape at 4255Hz; the nodes 33, 49, 65, and 105 are marked for comparison purposes with the experimental mode shape as shown in Figure 13

### 3.2. Machining experiments and modal testing on casing with 8 tuned dampers

To verify the dominant nature of the response, machining experiments were carried out with 8 tuned dampers mounted on the casing. It should be noted that these dampers are tuned for 4874Hz as this is the frequency which corresponds to 4724.7Hz in FE analysis. Similar machining setup has been used as in section 2.2. With the dampers mounted in place, the casing exhibited overall improvement in rigidity which can be observed by the absence of whistling high frequency sounds and machining characteristics akin to that of a solid block. The efficacy of damper blocks on machining was evaluated by calculating the Root Mean Square (RMS) value of the acceleration signal acquired during machining as shown in Figure 12. It can be noticed that the vibration signal was totally damped at the regions where the damper blocks were situated, and reasonable damping can be noticed in the intermediate area as well. A reduction in RMS value of 3.9 times is noticed across the area studied.



(a)

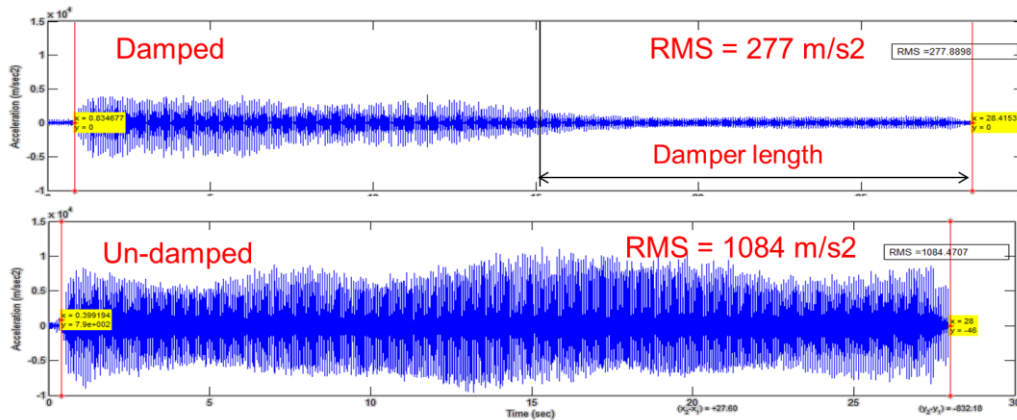

(b)

Figure 12. (a) Experimental setup of casing with TMDs and (b) Evaluating damper effectiveness through RMS value of vibration signal

The frequency spectrum of acceleration signal acquired inbetween two damper blocks during machining for one tooth contact, shown in Figure 13, clearly indicates the presence of a dominant mode, even after mounting 8 tuned dampers, at 4451Hz. When the time signal corresponding to different tooth contacts was analysed, it was noticed that this dominant frequency varied from 4445Hz to 4458Hz. To study the mode shape of this dominant mode, experimental modal testing was performed on the casing with the dampers mounted on it in the actual machining set up. The testing proved difficult, mainly due to two reasons: (a) damping of vibration across the dampers leads to an insufficient signal for the farther away accelerometer while causing overloading of the accelerometer nearer to the excitation point. This also affected the coherence of the measured frequency response. This was addressed by auto-ranging the hammer trigger level for different sections of the casing. (b) Most of the commercial modal analysis software packages have parameter estimation routines that assume proportional damping while converting experimental complex modes into real modes (which are useful in comparing with FE mode shapes). For a structure with local tuned viscoelastic dampers attached, such an assumption is not valid [39]. However, in this work, modal parameter estimation routines using proportional damping only are used.

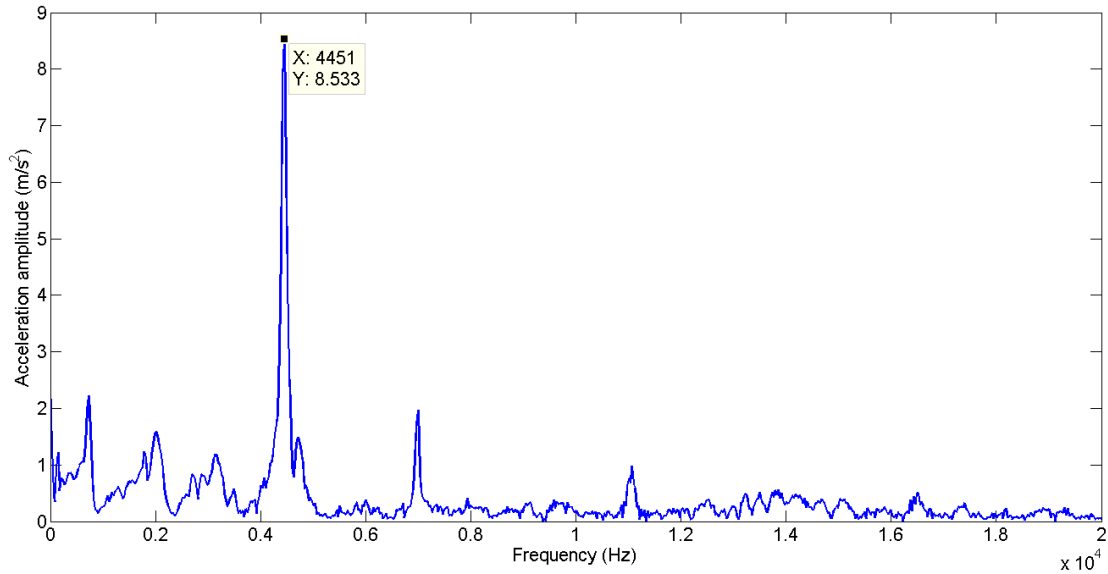

Figure 13. Frequency spectrum of acceleration signal acquired inbetween two damper blocks for one tooth contact

Figure 14 shows the mode shape of the casing with tuned dampers at 4490.79Hz; the mode shape correlates well with that of Figure 11(b) which shows that the FE predicted mode of 4255Hz corresponds to 4490Hz in actual casing. While it is difficult to appreciate the exact similarity between two mode shapes, some of the points used to observe the phase similarity are shown in Figure 11(b) and can be matched to identify the mode similarity. Also, the top profile of the casing of FE mode shape is overlaid in Figure 14. It is more likely that this mode is shown up as 4451Hz mode in the frequency spectra of the acceleration signal; the possible reasons for this difference of approximately 40Hz could be the interaction of tool and workpiece, machining conditions, etc. The variation in the FE predicted frequency of 4255Hz with that of the experimental modal result of 4490.79Hz could have occurred, in addition to the requirement of model updating, due to variation in the material properties of viscoelastic material and mild steel used for the damper blocks. The error from the finite element prediction methodology should be minimal since a direct integration technique was used, and hence FE approximations such as the consideration of viscoelastic properties at a single frequency are avoided. However, the total error is only 5% and the frequency variation in the un-damped casing itself is 3%. This demonstrates the high accuracy of the prediction of the dynamic response with tuned viscoelastic dampers on the casing.

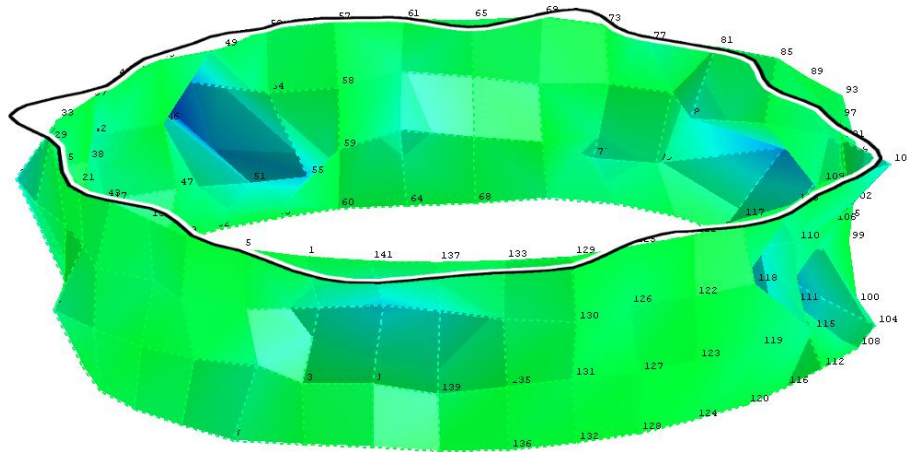

Figure 14. Mode shape of casing with 8 tuned mass dampers at 4490.72Hz; the FE mode shape profile of 4255Hz are overlaid on the top

#### 4. Conclusions

Damping of machining vibrations is crucial in achieving a better surface quality of the product and also to improve productivity by utilising aggressive process parameters. Thin-walled ring type structures are prone to workpiece vibrations during machining, and passive damping treatments are potential solutions to address this problem. In this work, a novel approach into modelling and utilisation of passive damping, i.e. tuned viscoelastic dampers, is devised to minimise vibrations on a thin walled casing. The paper brings into attention the following key aspects:

- No previous research has been reported in the literature on the dynamic behaviour of thin walled casings in highly dynamic processes such as milling. It has been shown that the casing studied in this work has a dynamic behaviour consisting of a dominant response from few modes at higher frequency prompting the usage of tuned dampers to minimise machining vibrations. This behaviour was validated using spectral analysis of the acceleration signal acquired during machining tests and also through experimental mode shape analysis. The variation in predicted and experimental natural frequencies of interest for un-damped casing is only 3%, and considering that this deviation is achieved without any model updating demonstrates the accuracy of simulation.
- Finite element simulation of the tuned viscoelastic damper was not previously reported for manufacturing applications. In the present work this is performed with a view to implement and validate a methodology for designing passive damping solutions as fixturing concepts for

large industrial thin walled structures. Frequency response predictions using FE analysis are validated through spectral analysis of machining acceleration signal and experimental mode shapes; predictions are made with an error of 5%. Considering that the un-damped casing predictions itself differ by 3%, such a variation of 5% for response simulation with dampers is considered to be very good.

- The benefits of tuned dampers in minimising the machining vibration are evaluated through the root mean square (RMS) value of the acceleration signal acquired during machining; a reduction in RMS value of nearly 4 times is observed when using the proposed passive damping solution.
- The damped dynamic response of the casing also showed a dominant mode, though with reduced acceleration, that is related to the vibration of the casing inbetween the damper blocks. It is likely that even a fully damped casing (continuous damping treatment) will have a dominant mode; this will be further investigated in future.

Overall, this work reports the dynamic response of thin walled casings with and without tuned dampers, and also throws some light on the behaviour of the structure when shell vibrations alone are treated with discrete damping solution. The accuracy with which the results are obtained and validated proves the benefits of using FE analysis for designing and validating the damping solutions in manufacturing applications, thereby achieving important benefits such as better surface finish and higher productivity while machining thin walled structures.

## Acknowledgements

The authors would like to thank EPSRC and Rolls-Royce for providing the funding under DHPA scholarship to undertake this research. Special thanks also go to Stuart Branston and Mark Daine of University of Nottingham for supporting all the experimental activities reported in this work.

## Appendix

**Table A.1** Frequency domain data for viscoelastic material 3M ISD112 [36]

Frequency (Hz)	Storage Modulus (Pa), G'	Loss Factor, $\eta$
0.1	7.00E+04	0.4
0.5	1.00E+05	0.6
1	1.40E+05	0.7
2	1.70E+05	0.8
3	2.00E+05	0.85
4	2.10E+05	0.9
5	2.40E+05	0.9
10	3.40E+05	1
20	5.00E+05	1
50	7.50E+05	1
70	9.00E+05	1
100	1.00E+06	1
200	1.60E+06	1
500	2.50E+06	0.9
700	3.00E+06	0.9
1000	3.50E+06	0.85
5000	7.00E+06	0.6
10000	9.00E+06	0.5

Relaxed shear modulus – 6.9e4 Pa, Poisson ratio – 0.49, Density – 1000 kg/m<sup>3</sup>

## References

1. Tobias, S.A., Fishwick, W., Theory of Regenerative Machine Tool Chatter, Engineering, London, 258, 1958
2. J. Tlustý, M. Poláček, The stability of machine tools against self-excited vibrations in machining, International Research in Production Engineering, 1963, 465–474
3. Sridhar, R., Hohn, R.E., and Long, G.W., 1968, A Stability Algorithm for the General Milling Process, Trans. ASME Journal of Engineering for Industry, 90, 330-334
4. I Minis, T Yanushevsky, A new theoretical approach for the prediction of machine tool chatter in milling, Transaction of ASME, Journal of Engineering for Industry, 115:1-8, 1993
5. E. Budak, Y. Altintas, Analytical prediction of chatter stability in milling—part I and II, Journal of Dynamic Systems, Measurement and Control, Transactions of the ASME 120 (1) (1998) 22–36
6. CUTPRO™, [www.malinc.com](http://www.malinc.com)
7. METALMAX™, [www.mfg-labs.com](http://www.mfg-labs.com)
8. L N Lopez de Lacalle, A Lamikiz, Machine tools for high performance machining, Volume 10, Springer publication, 2009, ISBN: 978-1-84800-379-8, pg.111
9. Research on Dynamic Simulation and Optimization Technology of Milling Process for Frame Parts of Marine Diesel Engine, Engineering Science Research paper, February 2012
10. U Bravo, O Altuzarra, L N Lopez de lacalle, J A Sanchez, F J Campa, Stability limits of milling considering the flexibility of workpiece and the machine, International J of machine tools and manufacture, 45, 2005, 1669-1680
11. Jiayuan He, Yan Wang, Nabil Gindy, Pre-tensioning fixture development for machining of thin walled components, 44<sup>th</sup> CIRP Conference on Manufacturing Systems, June 2011
12. K Ahmadi, F Ismail, Experimental investigation of process damping nonlinearity in machining chatter, Int. J of Machine Tools and Manufacture, 50, 2010, 1006-1014
13. Y.S. Tarng, J.Y. Kao, E.C. Lee, Chatter suppression in turning operations with a tuned vibration absorber, Journal of Material Processing Technology, Vol 150, 2000, 55-60
14. H. Moradi, F. Bakhtiari Nejad, M.R. Movahhedy, Tuneable vibration absorber design to suppress vibrations: An application in boring manufacturing process, Journal of Sound and Vibration, Vol 318, 2008, 93-108
15. Neil D Sims, Phillip V Bayly, Keith A Young, Piezoelectric sensors and actuators for milling tool stability lobes, Journal of Sound and Vibration, Vol 281, 2005, 743-762
16. Y Yang, J Munoa, Y Altintas, Optimisation of multiple tuned mass dampers to suppress machine tool chatter, International Journal of Machine tools and Manufacture, Vol 50, 2010, 834-842
17. Neil D Sims, Ashan Amarasinghe, Keith Ridgway, Particle dampers for workpiece chatter mitigation, Proceeding of IMECE 2005, ASME International Mechanical Engineering Congress, IMECE2005-82687



18. Yuanming Zhang, Neil D Sims, Milling workpiece chatter avoidance using piezoelectric active damping: a feasibility study, Technical note, Smart materials and structures, Vol 14, 2005, N65-N70
19. Amir Rashid, Cornel Mihai Nicolescu, Active vibration control in palletised workholding system for milling, International Journal of Machine Tools and Manufacture, Vol 46, 2006, 1626-1636
20. Amir Rashid, Cornel Mihai Nicolescu, Design and implementation of tuned viscoelastic dampers for vibration control in milling, International Journal of Machine Tools and Manufacture, Vol 48, 2008, 1036-1053
21. Neil D Sims, Vibration absorbers for chatter suppression: a new analytical tuning methodology, Journal of Sound and Vibration, Vol 301, 2007, 592-607
22. Chang J Y, Lai G J, Chen M F, A study on the chatter characteristics of the thin wall cylindrical workpiece, International Journal of Machine Tools and Manufacture, Vol.34, 4, 1994, 489-498
23. G J Lai, J Y Chang, Stability analysis of chatter vibration for a thin wall cylindrical workpiece, International Journal of Machine Tools & Manufacture, Vol.35, No.3, 1995, 431-444
24. Mehdi, K, Rigal, J.-F., Play, D, Dynamic behaviour of thin walled cylindrical workpiece during the turning process, Part1: cutting process simulation, Journal of Manufacturing Science and Engineering, 124, 2002, 562-568
25. Mehdi, K, Rigal, J.-F., Play, D, Dynamic behaviour of thin walled cylindrical workpiece during the turning process, Part2: Experimental approach and validation, Journal of Manufacturing Science and Engineering, 124, 2002, 569-580
26. Abaqus Analysis User's Manual, Volume II: Analysis
27. Y T Chung, L L Kahre, A general procedure for finite element model check and model identification, MSC 1995 World Users' Conference Proceedings
28. O.J. Bakker, Control methodology and modelling of active fixtures, PhD Thesis, University of Nottingham, August 2010
29. Conor D Johnson, David A Kienholz, Finite element prediction of damping in structures with constrained viscoelastic layers, AIAA Journal, 20(9), 1981
30. Yanchu Xu, Yanning Liu, Bill S Wang, Revised modal strain energy method for finite element analysis of viscoelastic damping treated structures, Smart structures and materials 2002: Damping and Isolation, 35-42
31. Hamid Movaffaghi, Olof Friberg, Optimal placement of dampers in structures using genetic algorithm, Engineering Computations, Vol 23, Iss 6, pp 597-606
32. Zhao-Dong Xu, Ya-Peng Shen, Hong-Tie Zhao, A synthetic optimisation analysis method on structures with viscoelastic dampers, Soil Dynamics and Earthquake Engineering, 23, 2003, 683-689
33. Nicholas J Oosting, Julie Hennessy, David T Hanner, Dave Fang, Application of a constrained layer damping treatment to a cast aluminium V6 engine front cover, Society of automotive engineers, 2005-01-2286

34. Jun Y Kim, Rajendra Singh, Effect of viscoelastic patch damping on casing cover dynamics, Society of automotive engineers, 2001-01-1463
35. Vasques C M A, Moreira R A S, Rodrigues J D, Viscoelastic damping technologies – Part I: Modelling and finite element implementation, Journal of Advanced Research in Mechanical Engineering, 1(2), 2010, 76-95
36. Marie-Josée Potvin, Comparison of Time-domain finite element modelling of viscoelastic structures using an efficient fractional Voigt-Kelvin model or Prony series, PhD Thesis, 2001, Mc Gill University
37. Oyadiji, S O, How to analyse the static and dynamic response of viscoelastic components, NAFEMS publication, August 2004
38. [http://www.deicon.com/tuned\\_abs\\_damper.html](http://www.deicon.com/tuned_abs_damper.html)
39. Balmes, E., New results on the identification of normal modes from experimental complex modes, Mechanical Systems and Signal Processing, 1997, 11(2), 229-243