



Publicly Accessible Penn Dissertations

1-1-2016

Information in Environmental Architecture: Ecological Network Analysis and New indices of Building Performance

Hwang Yi

University of Pennsylvania, hwangyilove@gmail.com

Follow this and additional works at: <http://repository.upenn.edu/edissertations>

 Part of the [Architecture Commons](#), [Environmental Sciences Commons](#), and the [Graphic Design Commons](#)

Recommended Citation

Yi, Hwang, "Information in Environmental Architecture: Ecological Network Analysis and New indices of Building Performance" (2016). *Publicly Accessible Penn Dissertations*. 2117.
<http://repository.upenn.edu/edissertations/2117>

This paper is posted at ScholarlyCommons. <http://repository.upenn.edu/edissertations/2117>
For more information, please contact libraryrepository@pobox.upenn.edu.

Information in Environmental Architecture: Ecological Network Analysis and New indices of Building Performance

Abstract

This dissertation suggests a new framework and indices of building performance evaluation based on an ecosystemic approach. The energy-efficient building construction and operation are important to achieve sustainability. Nevertheless, efficiency does not fully account for the building's complex environmental phenomena in which nature, art, and human living are inseparably involved. In particular, increasing efficiency cannot clearly associate the robustness and stability of the building's internal energetic organization (and trade-offs between energy efficiency and material use) with building form and occupant behavior. The purpose of this study is to argue that environmental information content is a substantial source to achieve building sustainability and to suggest that an emergy (spelled with an "m")-coupled information measure is the most comprehensive and holistic index of building performance.

Based on ecosystems theory, this dissertation defines building as a thermodynamic system that utilizes, transfers, and self-organizes the useful environmental resources—energy, material, and information—through networking processes. Definitions and formulas of information measures and ecological indicators from Shannon's information theory, Ulanowicz's ascendancy principle, and Odum's maximum empower principle are discussed and adopted to develop a new methodology of integrating building information and emergy and a model of building emergy-flow networking. A hypothetical generic building system is modeled and tested to characterize the building's systematic behavior with the examination of information change. Results of the hypothetical tests show that the informational characteristics of building emergy-flow networking parallels the phenomenological evidences of ecosystems development and sustainability—increasing complexity, resilience, fitness, and useful energy (power).

To verify the consistency between ecosystem development and building sustainability, experiments were conducted with two case study buildings: a net-zero energy building (NZEB) and a non-NZEB. Emergy-integrated information analyses according to the suggested governing equations and system models were carried out. Results show that the non-NZEB tends to be more resilient and adaptable and to have more "generative" empower (or total system information), even though the NZEB is more efficient. This indicates that high-performance (high-efficient) buildings may end up greater nonrenewable inputs. On the other hand, the investigation of the information content of building envelope demonstrates that human activities can generate the largest amount of useful information content than any other building system components, and the responsive building form coupled with smart human behavior contribute the most to increasing resilience, power, and information. Findings demonstrate that buildings self-organize internally, like ecosystems, with the inputs and outputs of resources. This eventually suggests that increasing complexity, total information, and power be the final goal of building sustainability and environmental building design.

Degree Type

Dissertation

Degree Name

Doctor of Philosophy (PhD)

Graduate Group
Architecture

First Advisor
William W. Braham

Keywords
building performance, complexity, emergy, Information, resilience

Subject Categories
Architecture | Art and Design | Environmental Sciences | Graphic Design

INFORMATION IN ENVIRONMENTAL ARCHITECTURE
ECOLOGICAL NETWORK ANALYSIS AND NEW INDICES OF
BUILDING PERFORMANCE

Hwang Yi

A DISSERTATION

in

Architecture

Presented to the Faculties of the University of Pennsylvania

in

Partial Fulfillment of the Requirements for the

Degree of Doctor of Philosophy

2016

Supervisor of Dissertation

William W. Braham, Professor, Department of Architecture, University of Pennsylvania

Graduate Group Chairperson

David E. Leatherbarrow, Professor, Department of Architecture, University of Pennsylvania

Dissertation Committee

David R. Tilley

Associate Professor, Environmental Science and Technology, University of Maryland

Ravi S. Srinivasan

Assistant Professor, School of Building Construction, University of Florida

INFORMATION IN ENVIRONMENTAL ARCHITECTURE

ECOLOGICAL NETWORK ANALYSIS AND NEW INDICIES OF BUILDING PERFORMANCE

COPYRIGHT

2016

Hwang Yi

This work is licensed under the
Creative Commons Attribution-
NonCommercial-ShareAlike 3.0
License

To view a copy of this license, visit

<http://creativecommons.org/licenses/by-nc-sa/2.0/>

ACKNOWLEDGEMENT

I thank Prof. William Braham from my heart. I can never thank enough, with any words, his affectionate support, guidance, and trust that I have received during my doctoral study and for this dissertation. I remember a beautiful spring day, about four years ago, when I first discussed with him energy theory and architecture, and after that, he suggested reading Ulanowicz's articles about information. It was the beginning of this difficult but very important work. What I learned from him was not only about explanations of theories or technical skills but his scholarly attitude, unwavering enthusiasm for teaching and research, confidence, and, most importantly, a sense of humor and generosity. His commitment to the advancement of environmental architecture has strongly influenced my architectural thinking and got me taken steps much further. Above all, the biggest lesson was that I realized asking an essential question is the key to solving a new problem. At this moment to take a step forward as a teacher and scholar, he means far more than an advisor to me.

I would also like to thank Prof. David Tilley. Even though I ran into him in my presentation at the energy conference, he was willing to be in the committee. I would have not been able to complete this work without his invaluable feedback and comments about ecosystem analysis and energy theory. I sincerely express my gratitude to Prof. Ravi Srinivasan for his strong encouragement. His ready availability and intellectual nourishment nurtured me. Moreover, his practical advice, as a former student of the University of Pennsylvania helped me finish my PhD study very well.

I am also indebted to the Korean members of T.C. Chan Center, Dr. Yoon-Soo Lee and Prof. Jihun Kim. Thanks to them, I felt at home in Philadelphia. I am also grateful to Prof. Santosh S. Venkatesh and Prof. David Leatherbarrow. Santosh spent time to give me technical advice about information study. Prof. Leatherbarrow's serious and earnest attitude to architectural thinking inspired me. Thank-you Prof. Ali Malkawi and my PhD colleagues in PennDesign, Xuefeng Gao, Pengyuan Shen, Linfan Liu, Sang-Phil Lee, Jae-Min Lee whom I met during this long journey. I enjoyed studying together. Thank-you MEBD students. I enjoyed a lot of conversations. I did not teach them but learned from them. Lastly and especially, thank-you my family and my fiancé, Christina Lee.

ABSTRACT

INFORMATION IN ENVIRONMENTAL ARCHITECTURE ECOLOGICAL NETWORK ANALYSIS AND NEW INDICES OF BUILDING PERFORMANCE

Hwang Yi

William W. Braham

This dissertation suggests a new framework and indices of building performance evaluation based on an eco-systemic approach. The energy-efficient building construction and operation are important to achieve sustainability. Nevertheless, efficiency does not fully account for the building's complex environmental phenomena in which nature, art, and human living are inseparably involved. In particular, increasing efficiency cannot clearly associate the robustness and stability of building's internal energetic organization (and trade-offs between energy efficiency and material use) with building form and occupant behavior. The purpose of this study is to argue that environmental information content is a substantial source to achieve building sustainability and to suggest that an emergy (spelled with an "m")-coupled information measure is the most comprehensive and holistic index of building performance.

Based on ecosystems theory, this dissertation defines building as a thermodynamic system that utilizes, transfers, and self-organizes the useful environmental resources—energy, material, and information—through networking processes. The definitions and formulas of information measures and ecological indicators from Shannon's information theory, Ulanowicz's ascendancy principle, and Odum's maximum empower principle are discussed and adopted to develop a new methodology of integrating building information and emergy and a model of building emergy-flow networking. A hypothetical generic building system is modeled and tested to characterize building's systematic behaviors with an examination of information change. Results of the hypothetical tests show that the informational characteristics of building emergy-flow networking parallels the phenomenological evidences of ecosystems development and sustainability—increasing complexity, resilience, fitness, and useful energy (power).

To verify the similarity between ecosystem development and building sustainability, experiments were conducted with two case study buildings: a net-zero energy building (NZEB) and a non-NZEB. Emergy-integrated information analyses according to the suggested governing equations and system models were carried out. Results show that the non-NZEB tends to be more resilient and adaptable and to have more “generative” empower (or total system information), even though the NZEB is more efficient. This indicates that high-performance (high-efficient) buildings may end up greater nonrenewable inputs. On the other hand, the investigation of the information content of building envelope demonstrates that human activities can generate the largest amount of useful information content than any other building system components, and the responsive building form coupled with smart human behavior contribute the most to increasing resilience, power, and information. Findings demonstrate that buildings self-organize internally, like ecosystems, with the inputs and outputs of resources. This eventually suggests that increasing complexity, total information, and power be the final goal of building sustainability and environmental building design.

TABLE OF CONTENTS

ACKNOWLEDGEMENT.....	III
ABSTRACT.....	IV
LIST OF TABLES	X
LIST OF ILLUSTRATIONS.....	XI
CHAPTER 1 INTRODUCTION.....	1
1.1 New perspective of building sustainability.....	3
1.1.1 Emergence of a new paradigm	3
1.2 New approach to the evaluation of building performance.....	6
1.2.1 Criticism on the mechanistic approaches and new questions	6
1.2.2 Need of a dynamic intensive system model in the evaluation of building performance.....	9
1.3 Building as an ecosystem: System networking of energy, matter, and information	11
1.3.1 Building as a living system and performance evaluation	11
1.3.2 Building as an energetic organization	15
1.3.3 Form of information: Encoding of energy and matter	17
1.4 Brief introduction of terminology and principles of systems ecology and information theory.....	20
1.5 Objectives and hypotheses of dissertation.....	21
CHAPTER 2 A REVIEW OF BUILDING SUSTAINABILITY ASSESSMENT METHODS: METRICS AND APPLICATIONS OF SYSTEMATIC APPROACHES	25
2.1 Assessment of building sustainability	25
2.2 Methods of quantification and accounting measures	27
2.2.1 Extensive methods (non-system-based approach).....	29
2.2.1.1 Single-criteria measures (SCMs).....	29

2.2.1.2 Summary and comparison of SCMs	40
2.2.1.3 Multi-criteria measures (MCMs).....	42
2.2.2 Intensive methods: System-based complexity measures	44
2.2.2.1 Information theory and Shannon index	45
2.2.2.2 Kullback-Leibler information.....	49
2.2.2.3 Fisher information: A local index of system behavior.....	50
2.3 Information entropy, thermodynamics, and applications to environmental studies	53
2.3.1 Information entropy and thermodynamics	54
2.3.2 Entropy, order, and disorder.....	60
CHAPTER 3 THERMODYNAMIC METABOLISM OF BUILDING SYSTEM AND NETWORK ANALYSIS	62
3.1 “A world of two metabolism” and global sustainability	63
3.2 Global thermodynamic principles of the analysis of an ecological system network	66
3.2.1 Order and disorder model and a metabolic understanding of building environmental functioning	67
3.2.2 Global principles of self-organization: Maximum entropy production and maximum power principle.....	69
3.2.2.1 Development of dissipative structure	73
3.2.2.2 Autocatalytic network and maximum complexity.....	74
3.3 Power and resilience: system-level indices of sustainability	75
3.3.1 Locality of building sustainability and information	77
3.3.2 Evaluation of information content: Quantification of power, organization, and complexity.....	81
3.3.2.1 Evaluation of reciprocal connectivity: Average Mutual Information	81
3.3.2.2 Probabilistic indicators of local system behavior	85
3.3.3 Application of an ecological understanding to building systems	101
3.3.3.1 Pros and cons of the eco-centric approach	101
3.3.3.2 Pilot test: Hypothetical experiment on the generic building network model.....	102
CHAPTER 4 DEVELOPMENT OF AN INFORMATION–EMERGY INTEGRATED BUILDING MODEL AND ASSESSMENT METHOD	109

4.1 General rule of development.....	109
4.1.1 Rules and theories of system modeling	109
4.1.2 Modeling procedure and components	110
4.2 Development of building network models.....	111
4.2.1 Extension of the order-disorder model into the chain of mutualism.....	111
4.2.2 Building network model of metabolism	113
4.2.3 Network model integrating the metabolism of the building envelope	119
4.3 Energy-information integrated formulation.....	123
4.3.1 Advantages of the energy metric system to the measurement of complexity	123
4.3.2 Computation algorithm for life cycle analysis.....	123
4.3.2.1 Whole building system analysis	128
4.3.2.2 Building envelope analysis	129
 CHAPTER 5 APPLICATION AND VERIFICATION	 131
5.1 Overview of case study buildings and methods of experiment.....	131
5.1.1 Description of the case study buildings and data collection	131
5.1.2 Building energy simulation: modeling and results	136
5.2 Energy analysis of the case study buildings.....	140
5.2.1 Energy synthesis of Building A (Baseline)	140
5.2.2 Energy synthesis of Building B (NZEB).....	144
5.2.3 Comparative analysis	150
5.3 Information analysis: Whole system	154
5.3.1 Annual variation during building life time (50 years)	155
5.3.2 Whole system: Monthly	159
5.4 Information of building form and human behavior.....	163
5.4.1 Effect of climate-adapted behavior to energy flow networking and information	164
5.4.2 Inputs and assumptions of model setup for behavior emulation	165
5.4.3 Simulation results: Information of building form and adaptive behavior	174

5.4.3.1 Envelope: Annual (life cycle analysis)	175
5.4.3.2 Envelope: Monthly (after 33 years)	179
5.4.3.3 Envelope: Hourly (after 33 years)	183
5.4.3.4 Significance of building form for the achievement of sustainability	188
5.5 System phase analysis	188
5.5.1 Diversity of inputs and outputs and the proxy of empower	189
5.5.2 Whole system (life-cycle and monthly observation)	190
5.5.3 Building envelope	196
5.5.3.1 Envelope: Hourly (after 33 years)	196
5.5.3.2 Envelope: Monthly (after 33 years)	201
5.5.3.3 Envelope: Annual (life cycle analysis)	205
CHAPTER 6 CONCLUSIONS.....	209
APPENDICES.....	214
BIBLIOGRAPHY	276

LIST OF TABLES

Table 2.1 Comparison of SCMs	40
Table 4.1 Categorization of metabolic compartments of building ecosystem	114
Table 4.2 Categorization and description of network flows for the whole building system.....	116
Table 4.3 Categorization of forward flows in the building envelope system	121
Table 5.1.1 Comparative description of test buildings	132
Table 5.2.1 Emergy synthesis of site work and structure (Building A, baseline)	141
Table 5.2.2 Emergy synthesis of building envelope (Building A, baseline)	142
Table 5.2.3 Emergy synthesis of mechanical systems and pipe/duct work (Building A, baseline)	142
Table 5.2.4 Emergy synthesis of interior work (Building A, baseline)	143
Table 5.2.5 Emergy synthesis of maintenance and renewable energy inputs (Building A, baseline)	144
Table 5.2.6 Emergy synthesis of site work and structure (Building B, NZEB).....	146
Table 5.2.7 Emergy synthesis of building envelope (Building B, NZEB).....	147
Table 5.2.8 Emergy synthesis of mechanical systems and pipe/duct work (Building B, NZEB)	148
Table 5.2.9 Emergy synthesis of interior work (Building B, NZEB).....	149
Table 5.2.10 Emergy synthesis of maintenance and renewable energy inputs (Building B, NZEB).....	150
Table 5.4.1 Building objects of physical management and factors in thermal comfort	166
Table 5.4.2 Simulation targets and parameters	166
Table 5.4.3 Parameters of probability distributions of other simulation factors	170

LIST OF ILLUSTRATIONS

Fig. 1.1 Which building is more sustainable?.....	4
Fig. 1.2 Analogy of building to living organism's metabolism	10
Fig. 1.3 What is the (environmental) building information?	18
Fig. 1.4 Ecosystem-based hierarchical understanding of environmental building types	22
Fig. 1.5 Hypothetic quantity-quality diagram	24
Fig. 2.1 Philosophy of sustainability assessment: reductionism vs. holism	27
Fig. 2.2 Extensive analysis vs. intensive analysis	28
Fig. 2.3 Thermodynamic relationship of energy, exergy and entropy	31
Fig. 2.4 Three major inputs in the emergy analysis	34
Fig. 2.5 Maximum power and efficiency	37
Fig. 2.6 Comparison of extensive analytic methods	41
Fig. 2.7 The whole extensive process of the building system and the scopes of the reductionist methods based on the traditional concept of each SCM	44
Fig. 2.8 Concept of Shannon information and Fisher information	49
Fig. 2.9 Transformation of the semantic level of information (knowledge)	55
Fig. 2.10 Intent and limit of the analogy in quantification	56
Fig. 2.11 Definition of information and two types of information content.....	60
Fig. 3.1 Conceptual representation of sustainability models	65
Fig. 3.2 Schematic system network model of building energy-matter metabolism	68
Fig. 3.3 Compatibility of global ecosystem development principles	73
Fig. 3.4 MePP, self-organization, and degree of global system development	75
Fig. 3.5 Concept of system resilience and duality of systems sustainability	80
Fig. 3.6 Representation of the AMI concept	82
Fig. 3.7 Formulation of AMI	83
Fig. 3.8 AMI is the measure of a network	84

Fig. 3.9 AMI is the quantum-based measure, a probabilistic distribution of quantum	83
Fig. 3.10 AMI is not the measure of intricacy of a configuration. Pruning of redundant paths increases AMI.	83
Fig. 3.11 Curve of system fitness and its maximum value	88
Fig. 3.12 Test of the measure of resilience (and robustness)	90
Fig. 3.13 General structure of a one-way flow system with n compartments	92
Fig. 3.14 Compartment efficiency (u) and information indices	94
Fig. 3.15 System efficiency, AMI, fitness, and robustness (bits)	96
Fig. 3.16 Final system efficiency and AMI	100
Fig. 3.17 Variation of complexity (H, total system uncertainty) and fitness	100
Fig. 3.18 Generic model of the building metabolic system	102
Fig. 3.19 Results of the pilot test	105
Fig. 3.20 Results of the pilot test: Export rate and information change	106
Fig. 4.1 Schematic global and building ecosystem model for environmental mutualism	112
Fig. 4.2 Emergy diagram of the whole building system network model	117
Fig. 4.3 Digraph representation of the whole building system network model	118
Fig. 4.4 System diagram of the building envelope metabolism	120
Fig. 4.5 Digraph representation of the envelope system network model	122
Fig. 5.1.1 Overview of test building A	134
Fig. 5.1.2 Overview of test building B	135
Fig. 5.1.3 Representation of EnergyPlus input geometry	137
Fig. 5.1.4 Energy use breakdown of a reference building (BA house) and simulation results of test buildings	139
Fig. 5.2.1 Comparison of empower	151
Fig. 5.2.2 Comparison of UEVs	153
Fig. 5.2.3 Quantity-quality plot	154
Fig. 5.3.1 Information contents of Building A and B (yearly)	155
Fig. 5.3.2 Information profiles of the whole building over the entire building life (50years)	158
Fig. 5.3.3 Information contents of Building A and B (monthly)	160

Fig. 5.3.4 Monthly information profiles of the whole building	162
Fig. 5.4.1 Emulation of human behavior in Building A at the ecosystem level	163
Fig. 5.4.2 Decision-making chart (Main loop)	167
Fig. 5.4.3 Decision-making chart (Sub loop: Cooling)	171
Fig. 5.4.4 Decision-making chart (Sub loop: Heating)	172
Fig. 5.4.5 Results of human behavior simulation	174
Fig. 5.4.6 Information content of the case study forms (yearly)	176
Fig. 5.4.7 Information profiles of the case study forms (yearly)	178
Fig. 5.4.8 Information content of the case study forms (monthly)	180
Fig. 5.4.9 Information profiles of the test cases (monthly)	181
Fig. 5.4.10 Variation of total system throughput (TST) and information content of system complexity (power)	184
Fig. 5.4.11 Temporal variation of the system-based indices at June 21th	185
Fig. 5.4.12 Temporal variation of the system-based indices at December 21th	187
Fig. 5.5.1 Empower profiles of test buildings (whole system)	191
Fig. 5.5.2 Total system information (TIs) and complexity (H)	192
Fig. 5.5.3 Phase plots: Total system information (TIs) and building performance	194
Fig. 5.5.4 Phase plots of information indices (whole building system)	195
Fig. 5.5.5 Empower profiles of test buildings (envelope) at June 21th	196
Fig. 5.5.6 Phase plots: Total system information (TIs) and building performance (June 21th)	198
Fig. 5.5.7 Phase plots of information indices (June 21th, building envelope)	199
Fig. 5.5.8 Phase plots: Total system information (TIs) and building performance (December 21th)	200
Fig. 5.5.9 Phase plots of information indices (December 21th, building envelope)	201
Fig. 5.5.10 Empower profiles of test buildings (envelope), monthly analysis	202
Fig. 5.5.11 Empower profiles of test buildings (envelope), monthly	203
Fig. 5.5.12 Phase plots of information indices (envelope), monthly	204
Fig. 5.5.13 Empower profiles of test buildings (envelope), life-cycle analysis	205
Fig. 5.5.14 Empower profiles of test buildings (envelope), life-cycle analysis	206

Fig. 5.5.15 Phase plots of information indices (envelope), life-cycle analysis208

CHAPTER 1

INTRODUCTION

Motivation and background

Sustainability has been studied and discussed over many scales in various disciplines. In architecture, nevertheless, it is still controversial to define what would lead to a sustainable building. As sustainability of contemporary buildings increasingly relies on energy-efficiency, we need more comprehensive ways to evaluate their environmental performance. However, several major problems are found in a range of environmental tactics as well as current performance evaluation metrics and methods, including that: (1) Building energy performance has been evaluated by modeling the building as if it is part of a mechanical product. All too often, due to the visually and physically solid enclosure, we regard it as an isolated object and discount inextricable direct or indirect connections to diverse contexts of social, economical, and environmental systems; (2) Energy use reduction is a very important technique of environmental design. Nevertheless, sustainability cannot be achieved solely by low energy use. It is necessary not only to consider what a building uses but also into what the building produces or contributes to the environment in a positive way. In this respect, the study of building sustainability requires a clear understanding of how building, its subsystems, and natural environment function collectively; (3) Environmental building design and management are concerned closely with a thermodynamic signature of mutual interactions among design elements (e.g., material use, infiltration, space size, lighting intensity, internal loads). Each building undergoes a singular situation within the mixed terrain of different thermodynamic contexts. Relative significance and function of a design element are thus contingent, and they end up with a dynamic behavioral pattern of environmental impacts. However, there is no clear performance index that can indicate the whole range of complex thermodynamic phenomena. Synergies, trade-offs, and conflicts that trigger an intensive change of the pattern are little addressed through the current extensive/reductive approaches to performance evaluation.

Many scientific tools of performance evaluation and impact assessment (building energy simulation algorithms, Life Cycle Assessment (LCA), rating standards, etc.) have been developed primarily from the perspective that views the building as a physical object, and, consequently, discussions about building performance tend to address direct influences and immediate operating energy demands; they have given less attention to the important question of how a building interacts with complex socio-technological backgrounds and/or large-scale environmental systems, which is eventually crucial to decision-making processes about geometry, material selection, and spatial programming.

Specifically, in terms of methodology, existing agendas of the sustainable building solutions (for example, zero emission/energy use) are intrinsically based on the “principle of thermodynamic equivalence” which is the essence of the classical Newtonian paradigm (Ulanowicz, 1997) whose fundamental assumption is that time and energy can be homogeneous and articulated. It apparently helps to explore the transport of mass and energy explicitly at the micro levels, but any attempts to make a general macro interpretation of all thermodynamic phenomena, however, are subject to criticism due to the emergence of the contemporary science: statistical mechanics, quantum theory, and cybernetics. The common ideas of these theories assert that everything is interdependent to one another indeterminately at any level and that a (thermodynamic) system can never be identified without taking into account the presence of an observer or other systems/elements involved¹. What we find from the system is, accordingly, just a snapshot of scores of probabilistic states of the system. Thus, it may be far-fetched to believe that an exact system performance (thermodynamic position) can be described.

Based on the recent awareness of a great deal of indeterminacy in building performance evaluation, a number of study have attempted to overcome uncertainty of metric systems and methods by incorporating new parameters and accurate data into a building model. Nevertheless, mechanics-based frameworks lack a clear account of how and why building communicates with the global environment, the openness of building elements to the universe, and/or the ambiguous causality that arises at any

¹ Wiener (1948) says, “In Newton’s dynamics, in its original form, we are connected with an individual system. However, in the vast majority of practical cases, we are far from that.”, and also contends, “Property of every element is the result of transforming an element.”

level of building performance analysis.

To address these concerns, it is desirable to focus on “relationships”, “interactions”, and the potential internal change that the complex building system undergoes. This idea is, in general, to acknowledge the empirical nature of building thermodynamics, i.e., dynamic balancing, that embodies multiple sequences of the various time-dependent events, but, more importantly, to underline the building’s capability of self-alignment, responding to external/internal variations.

Aside from the conventional capacity-oriented performance measures that are centered on resource stock and quantity in consumption (e.g., energy use and material use), understanding the building as a responsive dynamic system allows for new indicators to describe relationships of energetic flows and intensive “system” dynamics (such as homeostasis, resistance, or robustness of energy flow patterns) as more significant performance evaluators.

The complexity of performance emphasizes interactive relations and reciprocal variations of the building’s operational mechanism. It renders building sustainability with a new paradigm-shifting perspective; the energy-flow networking of the global environmental resources. At the end of the day, a system-based approach plays a key role to propose a new evaluation methodology of building performance.

1.1 New perspective of building sustainability

1.1.1. Emergence of a new paradigm

Despite the Rio declaration (1992), there is no general consensus on the notion of sustainability, and the definition of building sustainability is still debatable. Peacock (1999) categorizes the approaches to the sustainability into three concepts: (i) *business as usual*, (ii) *lifeboat*, and (iii) *mutual symbiosis*. The “business as usual” approach is very similar to the concept of “*technological sustainability*” defined by the environmental educator D.W. Orr (Van der Ryn and Cowan, 1996). It seeks to insist technical inventions are a panacea of all the environmental fear, and relies entirely on the foggy idea that either technological development or market solutions will resolve the demanding environmental pressure². It is important to realize that it is

² The Brundtland Commission's statement (“Sustainable development is development that meets the

too utopian to call for a fundamental innovation of sustainable building design.

The “lifeboat” is the most familiar, mainstream model that has also been used for the sustainability campaign in the design community. The lifeboat is a metaphoric expression to describe our planet’s limited carrying capacity of non-renewable resources. According to this idea, all human works are running down to be killed in the long run. There is no way that we avoid annihilation. The only action we can do is to restrict the rapid pace of resource depletion so as to delay the extinction as possible. It is horribly pessimistic. Proponents of this approach believe the rate at which a society operates must be restrained depending on the earthly supply given to us (Leadbitter, 2002; Meadow et al, 2003). As a result, of the crucial concern is overshooting of the building energy use, and, therefore, “efficiency” takes on the most important virtue while being employed to justify austerity of building design and occupants’ behavior.



Fig. 1.1 Which building is more sustainable?: Each building could be sustainable in a different manner. The building on the left-hand side is likely to contribute to the health of natural environment, while the right-side building provides some nutrients to the sustenance of economic/industrial systems.

However, Peacock strongly denies the extremist attitudes, and urges us to stay on

needs of the present without compromising the ability of future generations to meet their own needs (WCED, 1987).”) is representative of an underlying direction of this idea.

the ecological point of view — “peaceful coexistence” of man and nature through “symbiosis”. The lifeboat metaphor theoretically originates in the dualistic tradition of modern science that separates living things from physical environment, which eventually provokes a negativism — restraining the growth and development³. At ecosystem level, in contrast, all physical things as well as humans are not isolated individuals, but they are earthly biological components constituting the global ecosystem as a whole. Peacock likens the relationship between the earth and human civilization to heterotrophic organisms, and states the current environmental crisis due to the large amount of energy use and pollutant load is caused by parasitic association of the artificial and natural environment (Peacock, 1999). He emphasizes well-balanced mutualism between the host (the earth) and the parasite (civilization).

Notably, Peacock’s bio-metaphorical definition is perfectly in parallel with Cabezas et al.’s perception that “the concept of (ecological) sustainability applies to integrated systems comprising humans and nature (Cabezas et al., 2005).”, and manifested in an architect W. McDonough’s argument that “buildings, systems, neighborhoods, and even whole cities can be entwined with surrounding ecosystems in ways that are mutually enriching (McDonough and Braungart, 2002).”

This mutualism perspective provides a principled basis for dissolving buildings and natural environment; i.e., patterns of the building system organization are directly associated with the natural and man-made environment, and the largest ecosystem, the earth. McDonough and Braungart (2002) assert that only a successful marriage of biological systems and technological systems ensure sustainability. Therefore, engagement of human activities through buildings is critical in deciding whether or not the flows of energy and materials are in a virtuous cycle. As long as the sun provides the most integral energy source, our ecosystem possesses the power of energy regeneration and redirection of information in the circle.

Energy determinism (survival with emergency food supply) of the lifeboat concept is rooted in the culture of modern civilization that has sharply distinguished nature from man. The terror of unpredictability and loss of control over the nature have made us face the limits to growth of the human world (McDonough and Braungart, 2002). However, it should be noted that our world is “one of abundance,

³ Boltzmann recognized physical systems, unlike natural environment, become increasingly disordered or deteriorated with time, and the effortless transformation to higher orderly states is “infinitely improbable” (Boltzmann, 1886).

not of limits (McDonough and Braungart, 2002)” under “continuous construction (Prigogine, 2003)”, as long as we live on the earth. Which means the growth limit holds true only if it is meant to be an extension of the current ways and thoughts of human lives. Less nonrenewable energy consumption is important, but what is more crucial is the smart manner of utilizing the resources such as setting priority of fuel use (Campbell, 2004).

By incorporating the human attitude to cope with the environment in the definition of sustainability, the goal of sustainable growth can be switched from constraining the resource use to “perpetuating the cycling abundance of resources (Odum, 1971)”, because human intelligence and technological success are capable of acceleration of energy use intensity and effective arrangement of natural resources⁴ (Peacock, 1999; Campbell, 2004).

Mutual symbiosis runs counter to the widespread lifeboat concept and may not be immediately intelligible. But it provides a helpful view of our built environment that sustainable buildings can be more productive, progressively ordered so that they enrich the biosphere. Sustainable development of building means design of the building ecosystem. So, a self-producing environment (Swenson, 1997) that compensates the cost of making it is imperative. It is not covering over the terror of energy shrinkage, but generating useful power by well-disciplined activities with a clear purpose.

1.2 New approach to the evaluation of building performance

1.2.1 Criticism of mechanistic approaches and new questions

Kelly (2010) predicts that technology progresses into a certain direction on a macro scale, like biological evolution. For example, achievements of the machine age have driven our contemporary culture and the modern way of living to be shared, and for the inclination of universality has facilitated global exchanges of energy, material, and goods. As the energy capacity of the earth offsets a limit on the development of our civilization, increased concerns about energy issues (efficiency, scarcity, and the very importance!) became the most powerful and pressing constraints of building

⁴ But our culture, too often, ruins highly organized nature for the seemingly more structured to human understanding such as gardens, lawns, or row crops (Odum, 1994).

sustainability. And, to date, such concerns have led to the emergence of buildings equipped with highly efficient machines and with lower environmental impact.

A number of methods and techniques have been introduced and developed to facilitate the energy-efficient buildings. Proliferated for industry are nationwide certification standards (LEED, BREEAM, etc.) and accounting methods (e.g. LCA, Input-Output (I/O) analysis) based on various fields of knowledge. And more appealing terms such as net zero energy or net zero cost, have permeated into building design disciplines.

However, it is critical to point out that there are mixed signals from different definitions and measures of environmental buildings⁵. Although a few architects have questioned them, science of building assessment lacks an agreed metric or methodology that is fully available to all building types and timeframes. For example, building codes or rating systems such as ASHRAE 90.1 and Energy star, which are widely credited to US building industry, place significance on energy efficiency, but thereby, they underestimate energies embodied in building material use. LCA and I/O methods cover such drawback, but a target boundary the final impact arrives varies depending on applied fields.

On top of that, building analysts, mainly engineers, employ mechanistic techniques based on the conception that building components can be dissected to multiple elementary units of causalities (variation of glazing types and change thereof in energy use intensity). Afterwards, breakdowns for each element are generalized down to describe the overall behavior of a building. For such objects whose parts are combined in a straightforward fashion, mechanistic modeling is fairly powerful (Allen and Starr, 1982). However, this approach remains misleading of buildings in understanding interactive effects among the elements—sub-wholes as a matter of fact, on other lines of environmental stress, even though it may be a small bit, such as recycling rates, resource depletion, and so on.

Some of celebrated architects such as Frank Gehry or Peter Eisenman overtly express disagreement with present discourse of building sustainability, for designers are interested not in the results of energy-saving tactics, but in how individual

⁵ As a case in the United States, “State governments of Mississippi, Georgia and Alabama make efforts to ban federally adopted LEED certification system, claiming the USGBC’s closed-door approach and narrow-minded material interests have shut out stakeholders in various industries that could otherwise aid in the sustainable construction of environmentally-sensitive buildings (Cruz, 2013).”

treatments can be synthesized comprehensively to a formal gesture through design thinking. Unfortunately, no one clearly explains how the mechanistic tactics of low energy use became design conclusions, and often, codes of building sustainability end up creating a high-tech gizmo.

Living Building Challenge (LBC), a recently developed voluntary green building standard that attempts to characterize a building as a biotic creature, may be an alternative to the criticism aforementioned, but it is only partially illustrative because it lacks comprehensive compliances to a “living building” and evaluation of the highest energy performance is subject to the Net-zero energy definition.

Therefore, we must look into building and performance, cutting across time and physical barriers of space with a cosmological perspective, which means exploration of environmentally reciprocal relationships between design elements within an extended context. From a geobiospherical view, a building is inherently the outcome of energetic exchanges of environmental resources to sustain a physical climate-modifying form of material organization (Fernández-Galiano, 2000). Seemingly, it is hard to tell how natural resources are transformed into a built form. However, in effect, a building functions to have different kinds of substances and energies consistently interconnected under a formal organization. In this sense, the building is a highly-complex pseudo living system.

In a narrow observation, building’s environmental status generally looks as if it undergoes a steady variation; topological relationships of materials seem constant and thermostats work to turn on/off mechanical equipment within a certain range of temperature. In the macroscopic level considering multiple indirect influences, however, buildings dissolve human activities, social influence, and different cultural aspects. As a result, the building’s environmental task of climate-modification faces a great deal of uncertainty, as broadened environmental conditions unpredictably change. Measuring building performance is all about a specific internal reception on which the building takes by reacting to a certain denotative (spatially/temporally-varying) situation, given the external conditions. Accordingly, we need a better understanding of “complexity” of building functions and environmental systems that cannot be unveiled solely by mechanistic thinking. Performance evaluation becomes thus a subject of modern complexity science that has primarily to do with controllability based on feedback between entities and organization of interactive communications. In this regard, it is noteworthy that Weaver (1948) characterizes the

complexity of scientific problems with (i) unexpected behavior of human (ii) huge number of variables. This description characterizes the matter of building performance evaluation, revealing that problems with sustainable building design come under the label of complexity.

Then, with awareness of the complexity and living-systemic aspects of environmental building functioning, how could we measure performance? How should a building form look in order to be sustainable? A key point to finding answers is to see building's performance as a work of systematic phenomena in conjunction with the environment. Revisiting Weaver (1948)'s statements, he was convinced that a system as a whole has a certain "order" that is a specific property for a system status represented in averaged terms. If environmental buildings are the latest-evolved species benefitted from advanced technology, and, as Kelly insists, it is true a curve of high-technological system's development converges with a preordained ordering, like the Moore's law, in the same manner as biological evolution (Kelly, 2010), we would be able to track changes of an environmental "order" to identify propensity towards the final direction, as a measure of performance and sustainability. It may be accomplished by exploring parallelism between the structure and developmental sequences of living systems and those of buildings.

1.2.2. Need for a dynamic intensive system model in the evaluation of building performance

Current notion of building sustainability downplays systematic aspects of human-dominated environment, thereby revealing little about a general nature of building system's ecological behavior whose multi-interactive processing of energy and materials needs to be explicitly considered in design, construction, operation, and maintenance. To state the necessity of a new complementary evaluation framework, it is helpful to note that different methods of environmental assessment can be largely grouped into two categories; namely, "intensive or relative" and "extensive or absolute" (Kharrazi et al. 2013) that each of which needs a different approach, since "extensive properties depend upon the size of the system, but intensive variables are not affected by the size. (Ulanowicz, 1997)" Accounting for environmental building functioning with this categorization, input and output flows of resources through building systems are classified into an extensive domain, while energy transfers and

reciprocal relations of material and services between system constituents become the focus of intensive evaluation.

All too often, the present discourse of building sustainability evaluation deduces general formation of evaluation based on the input-output model in the static settings of macro state variables. Environmental impact of a building has been determined by amounts of resource consumption, greenhouse gas emission, or efficiency of mechanical systems⁶ that focus on the extensive realm, because not much is known about the complexity of the building system organization behind our observations, whereby it sets limits primarily to the external level of analysis—measurement of input-output relationships, leaving a building system a “black box.” However, in fact, a building amalgamates various kinds of input-output components, and each of which interactively responds to internal/external changes. The articulation of the response is also neither aimless nor accidental. Even a single organizational behavior definitely heads towards goodness for its sustenance. So, as far as we do not understand the logic of system dynamics, the building environmental impact may simply be shifted or rebounded (Zhang et al, 2010). For this reason, evaluation of building sustainability is often a chicken-and-egg problem, and the nature of the building system suggests that building sustainability should be characterized with system level attributes. In this light, the dynamic energetic networking of building should focus on environmental resource-flow organization, which has been characterized in ecological studies with system descriptors: resilience, feedback, and stability.

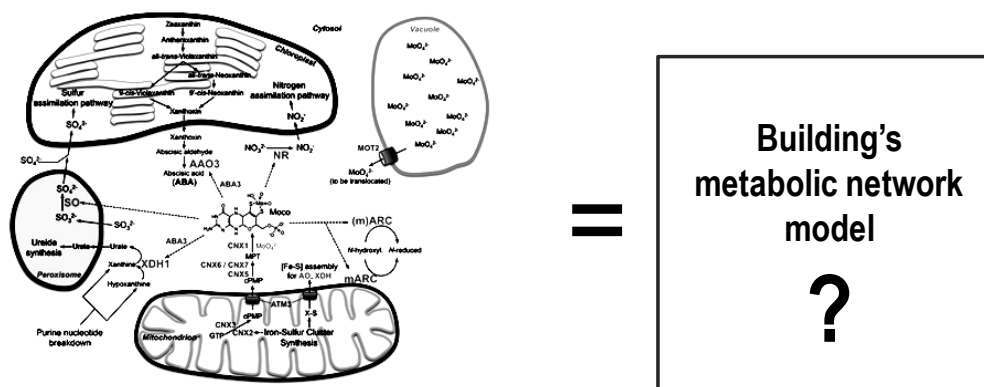

Fig. 1.2 Analogy of building to living organism’s metabolism: If building is a living system, general biological principles can mark the final goal of building system development.

⁶ LEED, ASHRAE 90.1

1.3 Building as an ecosystem: System networking of energy, matter, and information

“Ecosystems can exist in the dirt under your fingernail; and they exist in the rumen of a cow, and also on the regional, continental and planetary scale (Lovelock, 1979; Toussaint and Schneider, 1998).”

1.3.1 Building as a living system and thermodynamic analogy

William Cronon, in his 1991 book *Nature's Metropolis*, defines built environment as “second nature” atop the un-constructed natural world. Besides this, perception of building in association with natural creatures is not new to the architectural history. A building, in part or whole, has been likened to an animal or plant, and classical architectural styles have been described in mimicry of a human body. Semblance of a formal structure or a hierarchical assembly of parts found in living organisms was a target of architectural studies. Functional relationships of building components have also been characterized with those of the bodily parts performing specialized tasks⁷. And attempts to identify work of building functions with living organisms have agreed with an idea that “individual parts contribute to the effect or purpose of the whole (Steadman, 2008).” The principle of similitude was not only a central concept in the aesthetics of applied arts, but played a significant role in the production of architecture to reveal its wholeness and integrity.

Such biological comparison is desirable to some extent in that it provides a context in which we integrate variations of forms and functions of buildings with those of environmental systems. Steadman (2008) argues that an architectural style and formal characteristic resemble the growth of a plant as if they follow unconsciously certain rules of nature. Nevertheless, this identity remains half-baked

⁷ Galiano (2000) quotes F.L. Wright's saying, “Any house is a mechanical counterfeit of the human body. Electrical wiring for nervous system, plumbing for bowels, heating system and fireplaces for arteries and heart, and windows for eyes, nose, and lungs generally. The structure of the house, too, is a kind of cellular tissue stack full of bones (Galiano, 2000).”, and also Corbusier's writing that “...the physiology of breathing with the ventilation of buildings; of the nervous system with the networks of electricity supply ... the circulation of the blood with the circulation of people or traffic (Steadman, 2008).”

until we seek teleological “metabolism” that enables to explain an evident similarity in internal structure, organizational characteristics, and behavioral phenomena in presence of external changes. Limiting the analogical narratives to the physical boundary of a building, without any details of emulation of living processes, may distract our understanding or end up with formal imitation, functional determinism, or just a rhetoric metaphor. Technically, buildings are not organic creature but man-made objects. However, a model based on an eco-systemic analogy helps to overcome some difficulties to identify metabolic homogeneity with axiomatic ruling principles of the external physical world—laws of thermodynamics.

From Carnot’s elaboration, thermodynamic principles (energy conservation and energy degradation) in the 19th century had been affirmed as the universal laws that must be applicable to every phenomenon of the physical world⁸, Ludwig von Bertalanffy, an Austrian biologist in the early 20th century, proposed the first modern systems theory, General Systems Theory (GST), that proved the physical laws applicable to the development model of living organisms with a systematic perspective. After him, a mathematician Norbert Wiener, in his book— *Cybernetics: or the Control and Communication in the Animal and the Machine*, enunciated the validity of the keen relationship between living systems and mechanical systems by saying “the modern automata⁹ exist in the same sort of Bergsonian time¹⁰ as the living organism (Wiener, 1948).”. This locates the living organisms and the man-made systems under the same thermodynamic laws.

The bottom line of a thermodynamic analogy between buildings and living systems is in the notion of an “open system” that implies a living organism and ecosystems are associated with the outside world at every level, in terms of energetic exchanges. Based on this idea, some of ecologists in the 1950s made efforts to characterize behavioral patterns of individual organisms by analyzing greater multi-

⁸ “The second law of thermodynamics indicates a general tendency in the evolution of physical world (Brillouin, 1961).”

⁹ It could be understood as man-made machinery.

¹⁰ Henri Bergson defines time as “duration” that must be distinguished from the time that is perceived in abstract space of homogeneous occurrences. Duration can never be thought of as being separated from space, and always invokes a series of heterogeneous moments. Underscoring the fact that it identifies non-recurring events of natural cycles, Galiano (2000) states that Bergsonian time marks a “process of creation”.

scale engagement.¹¹ Eugene Odum (1959) thus named ecology series of this kind of study as ‘synecology’ against autecology whose research subject sets a limit on one or a few organisms. According to Hall and Fagen (1956), a system has three components: (i) object or component, (ii) attribute of object, and (iii) the relationship between the components¹². Because the metabolism of living organism interacts with external forces and other ecological entities, investigation of external relationships is fundamental to give better visibility on the rules of ecological process.

However, in exploration of the analogical relationship between ecosystems and technological environment to which buildings are subject, we face a major barrier that we must explicate if ecosystem’s behavioral characteristics can be valid in the same manner to building systems. If several principles of systems ecology are consistent with building systems, buildings can be considered equivalent to ecosystem and thus performance can be evaluated with analysis methods from ecosystem theories. In this regard, systems ecologists found a number of common characteristics in ecosystem behaviors. Three major principles established from their findings are: (i) *Self-organization*, (ii) *Dissipative structure*¹³, and (iii) *Reductive system*. (Odum and Odum, 1981; Jørgensen, 2000)

Self-organization is in fact the cardinal feature in the systematic understanding because it identifies the complexity of system that makes it difficult to apply conventional investigation based on the factor-result relationship. Wiener demonstrates that self-regulation is found in all kinds of systems during the development of feedback (or oscillation) loops. In ecology on the other hand, self-organization indicates that ecosystems distinctively transform for themselves properties of a network: attributes, number of components, and relationships, creating a particular form of the system hierarchy. It is an active process of adjustment, rearrangement, and creation of bodies of systems to adapt quickly to an environment for their survival, growth, and prosperity.

Every element of buildings, in fact, originates from nature. From the inference of

¹¹ The incipient appearance of the ecosystem concept dates back to 1914, much earlier before the ecosystem researchers employed the modern systems theory. Abolin, a Russian scholar, had used first the term *epigen* to correspond to the today’s ecosystem idea (Van Dyne, 1969).

¹² Schultz (1969) uses “elements” to refer to objects and “states” to attributes.

¹³ It is the characteristic of an open system. The term, “dissipative system or structure”, is first clearly identified by I. Prigogine, as a simultaneous characteristic of the self-organization, in his book (1977), “Self-Organization in Nonequilibrium Systems: From Dissipative Structures to Order through Fluctuations”.

the aforementioned principles, they are also ecosystems themselves. Not all may seem ecological, but in a macroscopic view, environmental behaviors of each building certainly resembles ecosystems, since essential characteristics of the building systems, self-assertiveness and cohesive tendency are also major properties of self-regulating open hierarchical structures (Koestler, 1967).

The long history of architecture shows many examples of self-organization. In terms of the fashion or style, from the primitive hut to modern skyscraper, buildings have been developed, not coincidentally but decidedly, to “complex” systems by communicating with social and cultural contents as well as useful environmental resources. Several demonstrations show our built environment is structured hierarchically according to distribution of the energy quality (Huang et al., 2001; Odum, 2007; Abel, 2010; Braham and Yi, 2014). Abel (2013) traced fuel use patterns of US households and revealed a social hierarchy of buildings has followed the principles of the ecosystems self-organization. It is partly because, in a highly-developed built environment, all parts are increasingly dependent on one another (Kelly, 2010).

When one seeks to extend the building system boundary to a whole society, however, care needs to be taken. Even though Odum (1981) showed the feasibility of self-organizing structures for human environment, Fernández-Galiano (2013) points out “lack of self-limitation” in sociocultural systems, quoting Eric Jontsch’s argument that “socio-cultural systems obey the law of biological life only partially.”, and, for that reason, he is skeptical on the fact that built environment would spontaneously organize itself under a certain thermodynamic rule. But he shows no clear evidence; what he insists is the potential inconsistency between Prigogine’s minimum entropy rule and human environment. However, he does not relate built environment to the law-like system-level maximum useful energy consumption, overlooking the fact that living systems always funnel energy into a large amount of dissipation towards growth and survival. Paradoxically, a highly-dense city reveals that the built environment responds to environmental crises by creating internal patterns of higher complexity. Environmental design is a conscious effort to make it in harmony with the environment, it is reasonable to assume environmental building systems will follow the biological laws. Zhang et al. (2006) also mentions built environment cannot be rigorously consistent with ecosystems due to the intervention of human activities, but apparently admits extrinsic variations change internal structures of a complex

artificial networking into higher adaptability. Braham and Yi (2014) presents that a contemporary building is constructed to follow the self-organization principle and building components consist of an energetic hierarchy. Open thermodynamic systems develop dissipative subsystems for the sake of metabolic activities. Every living organism of an ecosystem has a dissipative structure. Each of individual absorbs outside energy and matter as input sources. Then they are transferred to other organisms or thrown away in part. This dissipation process controls the speed of metabolic rates. The same holds true for building systems. A building requires a certain amount of external energy and materials for operation and maintenance, but they are degraded and taken out of a building after use.

Energy demands for building systems operation also clearly demonstrate buildings develop reductive systems to aid human living as plants maintain homeostasis through photosynthesis. Photovoltaic equipments attached to environmental buildings provide an analogical example. Then what remains is to look to how the system network interacts and move toward growth and self-sustenance, according to the level of system complexity.

1.3.2 Building as thermodynamic organization

“Architecture can be understood as a material organization that regulates and brings order to energy flow; and, simultaneously and inseparably, as an energetic organization that stabilizes and maintains material forms (Fernández-Galiano, 2000).”

Fernández-Galiano’s interpretation of a building replicates the ordinary characteristics of a dissipative thermodynamic system that imports useful energy and exports wasted energy to maintain a stable (living) state. As Wiener insists that all the elements underlying a system construction are held by “energy” and “its potential”, the essence of the systematic approach in the building-ecosystem analogy is to associate building systems with thermodynamic laws in which energy balance and the flow paths are determinant of all natural phenomena. Ecosystems obviously use an enormous amount of energy flows, and organize them in a certain order. In so far as mechanism of building systems is keenly tied to ecosystem metabolism, defining the medium of thermodynamic processes that interlink system components should be the core task to identify building systems.

In the tradition of biological study, the mechanism of a living system is identified with metabolized works of three cardinal quantities: (i) *energy*, (ii) *matter*, and (iii) *information*. (Jørgensen, 1992; Gatenby and Frieden, 2007). Jørgensen argues that those are driving constraints and inextricably connected inputs to which all systems behaviors are subject. Reception, storage, transmission, and utilization of the three elements dominantly contribute to settle a system into a particular state. Different fields of science use the terms in different contexts, though, to put it coherently in system study literature, energy is a capacity of activities whose two major categories are heat and work. Matter is generalized to refer to the physical substance of any material having mass whilst at rest. In living organisms, information is usually referred to as an inherited knowledge. Energy, matter, information are commonly inputted to create system objects and go through depreciation with temporal flows.

However, a question may arise; do flows of the elements through a system have dominance over each other? The answer is no. Matter and energy are equivalent as one can be converted to estimate the other. Matter can be seen as a statically concentrated carrier of energy, and thus, its quantification takes on a commensurable metric of energy. What is noteworthy is the role and traits of information. Although, information is a formless quantity, it can be treated as a coequal thermodynamic property as energy and matter (Cabezas and Karunanithi, 2008) in that it plays a central role in mapping of a genetic expression with energy and matter. But the behavioral aspect of information is quite different among other elements. Matter and energy are conserved and some of useful content can be recycled for regeneration; the same statement does not hold for information. Instead, while available energy and matter could be limited in existence of a living system, information can be reproduced and transcended for the evolution of the system (Brown, 2005; Kelly, 2010). Since amplification of information is much easier than investment of energy and materials for reproduction (Tribus and McIrvine, 1970), a small quantity of information is capable of reorganizing fluxes of energy and matter and a specific transaction and arrangement of energy and matter are directed only by information (Gatenby and Frieden, 2007). For this reason, some researchers (Fath et al., 2003; Nielsen, 2000; Straskraba, 1995; Brooks and Wiley, 1986; Wicken, 1987) argue that an ecosystem is an “information system” as they take information as the most critical constraint of environmental systems development.

The use of thermodynamic explanation with energy, matter, and information is

effective to drawing some useful principles of environmental building design. A building plan can contain all the information for a single building. During construction, great deals of material are transported to the site, and the building consumes energy for operation, responding to the embedded information. It is quite similar to the way a living organism grows. Therefore, the definition of a building as “a thermodynamic engine”¹⁴ is explained with combination of the three constraints. A building as an open system absorbs, transfers, disposes energy, matter, and information in order to maintain itself away from thermodynamic equilibrium. Analyzing three elements separately will end up with incomplete knowledge to understanding building system’s functioning as a whole. Meanwhile, along with Fernández-Galiano’s assertion, the building form of environmental building is a physically revealed but “embodied” form of information to adjust the balance of energy and matter (Braham, 2015).

1.3.3 Form of (environmentally useful) information: Thermodynamic encoding of energy and matter

“From one cosmic perspective, information is the dominant force in our world. (Kelly, 2011).”

Information, which is a primary term in this dissertation, corresponds to non-physical, formless knowledge as in its everyday sense, but it should also be understood as a physical quantity that pertains to the arrangement of energy and matter in a system network. Limiting implications of information within a single definition may risk its applicability. Multiple applications of information-related terminology in various fields make it occasionally metaphoric and misleading in translation.

The modern system-based definition of ‘information’ was emerged from Wiener’s *Cybernetics* in 1948. His enthusiasm for the human-machine analogy led to a mathematical study of the signal delivery mechanism based on quantum physics and Gibbsian statistical mechanics. As a scientist, his concern was ultimately with the control of simultaneous interaction through the integration of system and signal from

¹⁴ cf. Wiener (1948) proclaims, “The living organism is above all a heat engine”.

the outside. He defined information as “a message driving the internal mechanism into a specified direction (Wiener, 1948)”. Subsequently, three Russian cyberneticians, Aleksei Liapunov, Anatolii Kitov and Sergei Sobolev, expanded Wiener’s idea. They maintained that information is any sort of external data that is absorbed, processed, or produced within a system (Mindell et al., 2003). This stimulated the untapped potential of the term. Information was immediately transferred to different fields: data processing in computer, environmental change, genetic structure in biology, anthropogenic phenomena, human knowledge, etc.

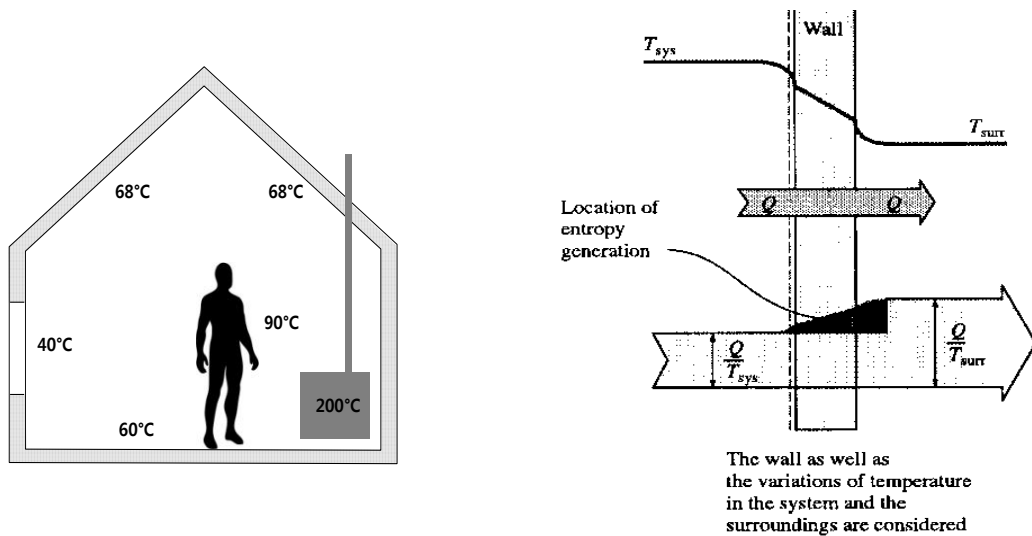

(a) Distribution of conductive heat inside the building

(b) Generation of information (from Dincer and Cengel, 2001)

Fig. 1.3 What is the (environmental) building information?¹⁵

In spite of the widespread multidisciplinary use, the definitions of information in the related disciplines (biology, communication, computer science) can be succinctly described with a double nature, i.e., (i) semantic information (useful meaning or instruction encoded in a system process as a form of a signal, bits, or data), and (ii) syntactic information (the sequence and structure of data). The semantic interpretation

¹⁵ A building form can be understood as the key director of information generation. (a) A building “organizes” energy flows. Particles of imported heat (high-quality energy) are unevenly distributed through the entire building envelope and they create a certain form of heat “gradient” over the surfaces. (b) The building form regulates generation of an energetic order: The wall’s control of heat exchange generates temperature difference and entropy that corresponds to information change of the building system. This example clearly demonstrates that building energy transport always integrates matter and information, and also that higher information indicates higher utilization of matter and energy

is based on the commonality underscoring qualitative aspects and, therefore, familiar to us, but the syntactic definition gives a clue that information could be used for indicating the magnitude and quantity of data and its structural configuration.

This dual nature of information can confuse the selection of technical measure of information. Randomness and unpredictability of data processing prevent the use of qualitative measures of communication. However, Hegel's proposition reminds us that the nature of quantity is a return to a change in quality, and also "quality and quantity are united in measure (Hegel, 1816; 2010)", the two categorizations of the information definition are not indifferent each other, they are two sides of the same coin.

In architecture, an incipient source of information is the architect's (or client's) idea of design and planning. In turn, it is accumulated in form throughout the construction phases. So one may call a building *information memory*. However, the memory is decoded and encoded (spread, amplified, transformed, and mutated) by the various channels (e.g. occupants' lifestyles, adaptation to changing environment) throughout the building's life cycle.

Information in this dissertation is defined as the building's capacity for engagement, by tuning up its subcomponents such as human life, supportive social backgrounds, and physical elements. A first hypothesis is that such informational ability appears through the building's systematic networking. Therefore, building information could be anything that characterizes energetic flows across the components (e.g. operational energy, material, etc.). Note that a critical second hypothesis is that the process of information change is comprehensively embedded in the 'building form' which adjusts and controls the flow of the information content (Fig. 1.3).

On the other hand, from a cosmological view, Kelly (2011) finds that information holds dominant power in shaping the technosphere. He explains, in the formation stage, i.e., Big bang universe, radioactive force was paramount, but afterwards, matter became the most prevailing with the creation of biosphere (Kelly, 2011). Since information imparts order and pattern to a system (Ulanowicz, 1997), information has been accumulated gradually throughout developmental stages of the environment, and now information governs all biotic/abiotic processes on Earth. Evidently, this argument is consistent with the idea that information has the highest quality of energy (Odum, 1988; Tribus and McIrvine, 1971).

Therefore, a building form as an information system is an “*exosystem*” (Fernández-Galiano, 2000), wherein continuous inflow of dematerialized force and energy maintains an (thermodynamic) order of a building system. Energy and matter can be easily measured and integrated as an energy account, since both are theoretically interchangeable substances. However, it is important to note that the building as a living system do not take in information directly, but information obtained from the incoming matter and energy is used up to agitates the system’s internal structure of energy transformation processing. Information is thus created, destroyed, and augmented while in processing of energies and materials. Hence, it can be said that a small amount of energetic exchange may cause a building system to have a entirely different energy flow structure. (Aynes, 1976). At the moment, the building energy structure takes on a certain exosmotic order of complexity.

1.4 Brief introduction of terminology and principles of systems ecology and information theory

Energy (spelled with an “m”) is crucial to describing environmental phenomena and principles in this study. It is an accounting metric that measures embodiment of all types of useful environmental sources. Energy enables to appraise energy quality and hierarchy of an environmental entity or process. Greater energy concentration generally leads to greater energy and higher quality of output energy. Ecosystem’s developmental tendency to maximize useful energy is explained with the maximum energy power principle. On the other hand, based on information theory, an amount of uncertainty in probabilistic distribution of energy is related with a definition of building information content. Information is channeled through the building system, and the built form is a paramount agent in environmental building performance and impact. Odum’s energy power basically takes on an extensive perspective, while measuring information originated from an intensive analysis. Not only that, information cannot be directly quantified, since, (i) by definition, it is observed only with system’s internal structure change (network configuration); (ii) the capacity of a source of the human/building information is unknown. Nevertheless, by introducing information as a thermodynamic quantity, maximum power principle can account for why environmental buildings increase information, because involving human (genetic) information for building operation tends to increase power by developing a feedback

loop. A number of other ecosystem/environmental indicators are discussed and compared in detail with thermodynamic principles in Chapter 2 and 3.

1.5 Objectives and hypotheses of dissertation

This dissertation addresses an intensive domain of performance evaluation and develops a new methodology for the holistic evaluation of building performance. To this end, models and methods incorporating flows of energy (spelled with an “m”) and information are established, so that building information content can be used to describe both qualitative and intensive aspects of sustainability in the processing of energy and material. This study identifies building thermodynamics with an interconnected dynamic networking of individual environmental flows. From an advocacy of the building-ecosystem analogy based on a thermodynamic understanding and awareness of the problems in current performance evaluation methods, this dissertation applies theorems of systems ecology, thermodynamic principles, and information theory, so as to clarify living-system-like building’s environmental functioning at the system level and eventually to argue that an energy-integrated information is a holistic index of building sustainability. Specifically, this study is primarily based on Shannon’s mathematical definitions of information (Shannon, 1948), Ulanowicz’s ecological interpretation of information theory (Ulanowicz, 1986; Ulanowicz, 1997), and H.T.Odum’s principles of ecosystem behavior (Odum and Pinkerton, 1955; Odum, 1971; Odum, 1996).

Applications of network-based thermodynamic flow analysis to test cases seek to justify the building-ecosystem analogy, describe the characteristics of system development consistent with the general notion of building sustainability, and determine which kind of a building form and design is sustainable. Explanations of the methodology will be followed by suggestions for a new vision of sustainable architecture. Following hypotheses and ecological principles are explained and demonstrated with test buildings.

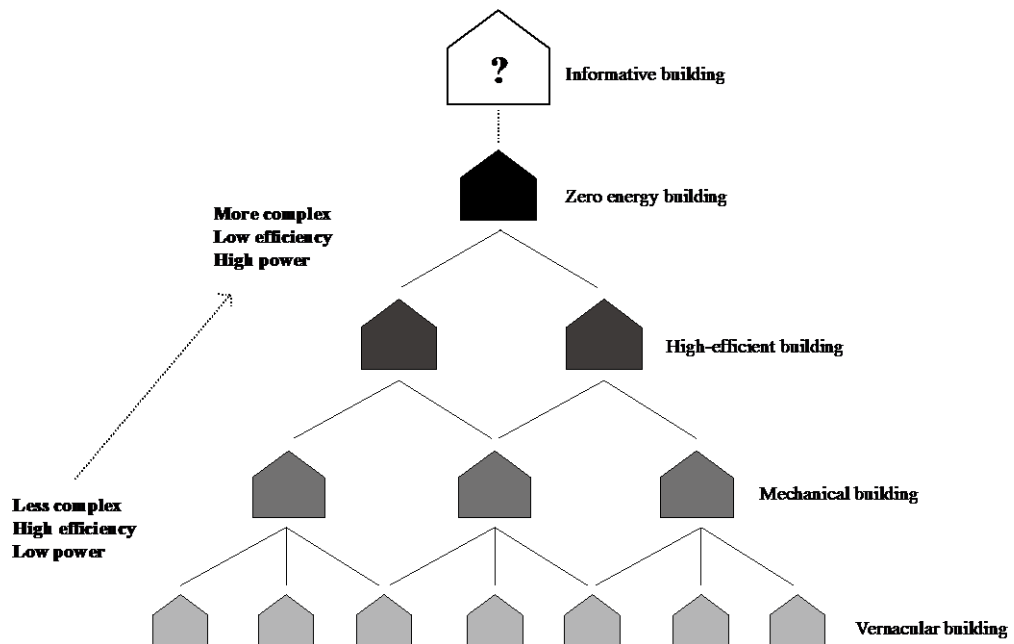

Fig. 1.4 Ecosystem-based hierarchical understanding of environmental building types¹⁶ (Sustainable building performance is not about increasing efficiency but power)

(1) Parallelism of ecosystems metabolism and building energy dynamics is substantiated, under thermodynamic principles, at all spatial and temporal levels. Individual phenomena we experience may be a highly contingent under random variations, but they can be explained with general principles of ecosystems growth and development (especially maximum power principle).

(2) Building and subsystems are subject to a certain energetic hierarchical

¹⁶ This figure shows that historical developmental trends of environmental building types have been dependent on the system power, not efficiency. Vernacular buildings made of natural and local materials, without mechanical systems (e.g. a primitive hut), tend to carry less power, but their efficiency in terms of thermodynamic is very high, because there would be no significant difference between the inside and outside temperature and, thus, it is fully-reversible. As mechanical systems attached for thermal comfort, buildings become endo-irreversible, and efficiency decreases as the building undergoes more complex energy transformation processes. According to the ecosystems principles, such genealogical development of the environmental building type is quite natural, however, sustenance of the present hierarchy whose power sources rest mainly upon nonrenewable (e.g., fossil fuel, industrial goods) sources is highly contingent on the source availability, and must be vulnerable if the resources become scarce. In this respect, zero energy building is just another developmental type following this way. However, information functions as a quasi-renewable source, because it is readily available, and its high quality help increase power as well. So, one may expect that future sustainable building would be more informative.

structure which is likely to have a high degree of complexity and an optimized (intermediate) level of efficiency in the structural organization as ecosystems are. For this reason, both maximizing power and increasing information content become a common tendency of sustainable buildings and building forms (Fig. 1.4).

(3) A sustainable building form tends to self-organize functional interplays between internal and external coordinates of environmental resource flows. Since a resilient thermodynamic system gives feedback on its performance with greater potential of system learning and self-adjustment (Hasseler, 2014), it can be expected that highly resilient building would construct an energy transmission circuit to a high degree of potential human engagement and end up increasing information. In a system's state of high resilience, the building form becomes a game changer in the whole system functioning towards sustainability (Fig. 1.5). As a biophysical order is inherited through a certain "form" of DNA or a cell (not directly through genetic information), it is assumed that the building form is the final director over all building system behaviors and it seek to accumulate the genetic information while in responding to environmental conditions.

Major challenges regarding demonstration of the above hypotheses are:

- Identification of thermodynamic process in construction and operation of building systems.
- Building ecosystem modeling (definitions of the system boundary and components)
- A clear substantiation of how information indices can be incorporated into environmental building studies, provided that integrated indices can identify flow structures of building materials and energies.
- Development of building performance indicator systems and computation algorithms that enable to integrate energy units and the definition of information.
- Evaluation of building information content to characterize a thermodynamic status in a quantitative manner.

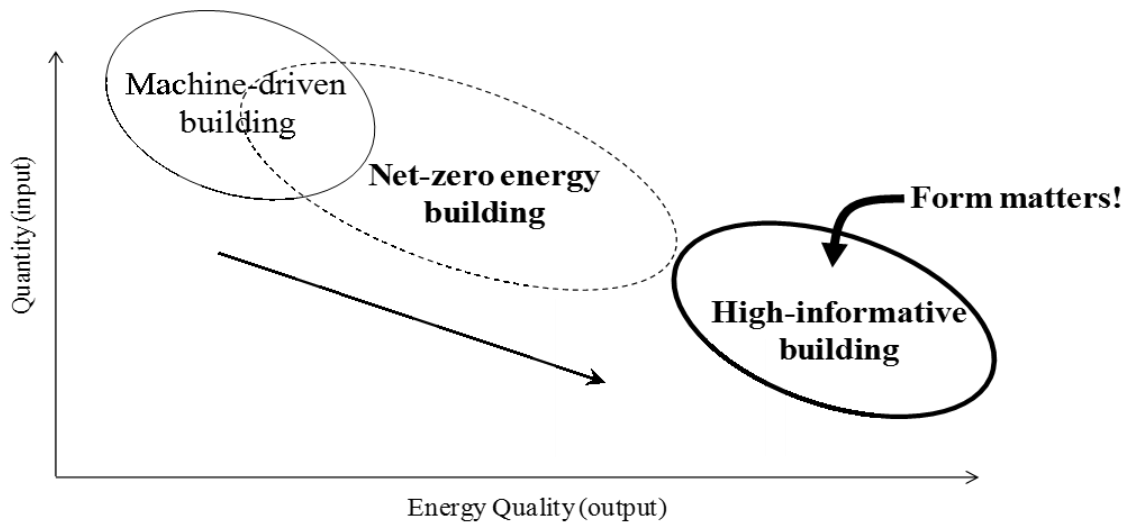

Fig. 1.5 Hypothetic quantity-quality diagram: Sustainable building shall be highly informative. Increased information content works to reduce the quantity of energy usage, while increasing the quality of the energy. An information-based understanding of building performance gives a scientific rationale for the tendency to increase information content of the future sustainable building, and also justify why we should explore information of the building form.

CHAPTER 2

A REVIEW OF BUILDING SUSTAINABILITY ASSESSMENT METHODS: METRICS AND APPLICATIONS OF SYSTEMATIC APPROACHES

2.1 Assessment of building sustainability

A goal of assessing building sustainability is to quantify the capability of a building to manage, conserve, and restore environmental sources, based on the measures that are bound to underlying ecological constraints. It is used to weigh a resource balance, to establish a direction and a rate of development or for benchmarking. Kharrazi et al. (2013) characterize the three categories of general constraints in environmental development: (i) resource availability, (ii) limits to inputs, and (iii) consumption efficiencies.

Specifically, if one sought to understand the nature of what is to be evaluated for buildings, there are challenges directed into twofold, i.e., “capacity” and “efficiency”. In effect, environmental resource availability and input limits of goods and services delineate a productive capacity of the social/natural environment. Efficiency depends on the rate of resource use, as well as various system-operation schemes of throughput management.

Capacity concerns donor-side aspects, addressing a consumer’s overall demands, whereas efficiency refers to the user-side ability to handle disposal processes. Each of which is mutually indispensable, and, in general, one cannot take absolute precedence over the other. For instance, if efficiency of consumption is a parameter which demonstrates the amount of resource used to provide heat, lower capacity (reduction of space heating demand) requires higher efficiency of machines, and lower efficiency demands a greater amount of carrying capacity of heating sources. Leslie White’s pithy formula that $E \times T \rightarrow C$ ¹⁷ (White, 1949) also implicitly highlights that the degree of sustainability is reinforced by correlation of the two factors. For a more

¹⁷ E denotes the amount of energy used, T is the quality or efficiency of the tools employed for harnessing the energy, and C is the degree of cultural development (White, 1949).

general definition, the expression could be rewritten as a cross product function of two vectors as below,

$$\mathbf{B} = \mathbf{C} \times \mathbf{I} \quad (2.1)$$

where \mathbf{B} denotes the degree of building sustainability, \mathbf{C} is the capacity-related factors, and \mathbf{I} is the efficiency-related variables. To be specific, the quantity of matter and energy are related to \mathbf{C} , and \mathbf{I} can be a flux density or a degree of concentration of matter and energy. Note that the final indicator \mathbf{B} has both a magnitude and a direction whose interpretations and dimensions depend on the attributes of the inputs.

The symbiotic translation between two terms does not prevent trade-offs between them, and occasionally it is being misused, or interrelations are overlooked. “Net-zero”, for example, means that 100% efficiency ensures an unlimited virtual capacity of nature or economy invested (Pless and Torcellini, 2010). But this enthralling assumption misshapes what a sustainable building is for. It does not explain different thresholds of throughputs, and not acknowledge that renewable resources are “forms of potentially unstable energy” which are not limitless (Odum, 2007; Srinivasan et al., 2012). In addition, energy or cost payback scenarios do not shed full light on future uncertainty since a building may not be working in the same way as it does at its birth (Fernández-Galiano, 2013). Net-zero definitions seem to rely on a short-term payback of any kind. Based on an understanding of the various strata of the relations between capacity and efficiency, an appropriate building sustainability quantification method will depend on two considerations: (i) the “medium” to be used for analysis and (ii) the “system definition” that is dictated by a scope of analysis (Zhang et al., 2010a). Both have much to do with the approach to understanding of buildings, including establishment of hypothetical models for sustainability evaluation. An appropriate quantitative measure of building sustainability can be derived from an investigation of the parameters characterizing a building as an ecosystem (energy, matter, and information) whose attributes vary according to variations of the two terms of sustainability: capacity and efficiency. Prior to a new suggestion, existing methods employed for environmental building studies are presented and critically reviewed in the next sections. Section 2.2.2 introduces methods of an intensive system measurement that is new to building sustainability, which provides essential concepts

and techniques for this dissertation.

2.2 Methods of quantification and accounting measures

A building is bound to a set of natural/technological/social systems, which is demonstrated by (i) the number of variables to define the building system is extremely high, and (ii) the orientations and properties of numerous component connections are all different, and vary interactively. So, in order to examine sustainability, a large number of data sets representing the real system need to be gathered through a series of observations or experiments. Munda (2006) analyzes that sustainability assessment methods are developed by setting: (i) a purpose of evaluation, (ii) scale of analysis, and (iii) set of dimension, objectives, and criteria (Munda, 2006). Based on the above factors, the methodological approaches to characterize the complexity can be grouped into (i) reductionism and (ii) holism, according to the dimension of measurement, types of media, and the number of indicators to describe system performance (Fig. 2.1).

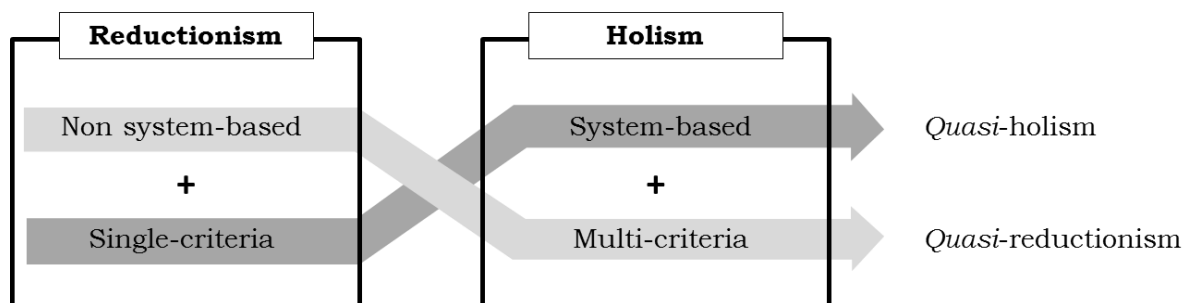

Fig. 2.1 Philosophy of sustainability assessment: Reductionism vs. holism

The perspectives to which each method holds can be subdivided largely into (i) extensive analysis (non system-based) and (ii) intensive analysis (system-based) (Fig. 2.1), depending on the level of resolution of the system structure, and the scale of analysis. One might be confused about the use of this classification because they are illustrated somewhat differently in the literature. Especially, several studies considered intensive analysis to be tantamount to holistic evaluation. For example, Jørgensen (1992) uses reductionism and holism in the same way as the distinction of

the extensive and intensive analysis. Munda (2006) distinguishes reductionism only in terms of the number of criteria, while Reed et al. (2005) contrast reductionism against system-based approaches.

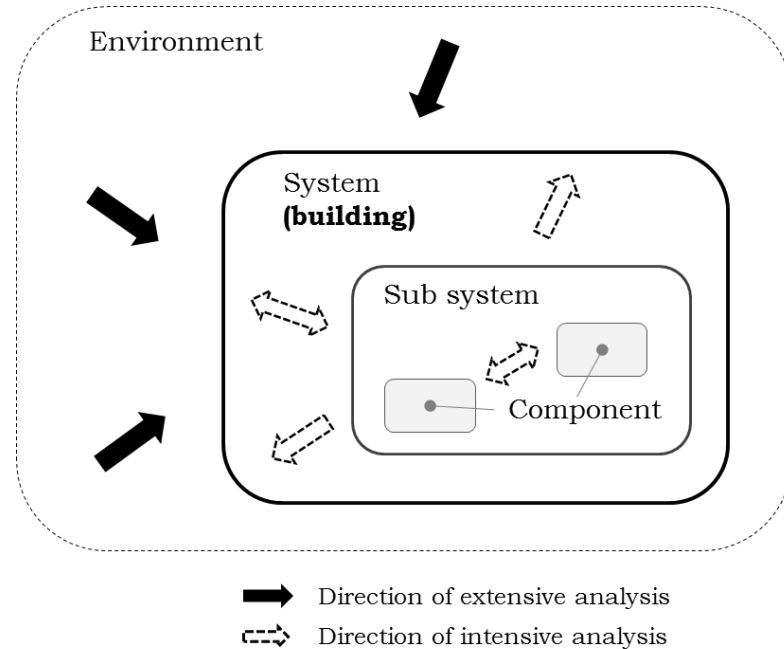

Fig. 2.2 Extensive analysis vs. intensive analysis

It seems apparently true that the resolution of the system structure under analysis renders a clearer definition for this distinction than the number of indicators. Notice, however, that selection of criteria is dependent on the structural detail. The extensive-intensive categorization sets the definition on the scope and the subject of accounting variables and data observation. At a molecular level, for instance, trajectory of movement, external work, volume of a molecule, and interaction between molecular particles, which depend on the size of a system, are the sources of external analysis. In contrast, intensive analysis deals with density, pressure, or internal temperature of the molecule, which identifies arrangement of the molecule structure. On the other hand, this reductionism-non-reductionism distinction concerns the way of conducting the observation and the final outcome of quantification. Reductionism is fundamentally based on a mechanistic point of view, taking for granted the common misconception that a total equals the sum of parts. As a result, reductionist methodologies do not consider an inner state of the system. Various complex phenomena during system processes fall into a set of causality of inputs and outputs, and monitoring system

variations condense to a single or few key indicators (Reed et al., 2005). On the other hand, the holistic view emphasizes the local context of and internal change in the system. In the holistic framework, multiple techniques and tools can be implemented in different phases throughout the analysis, and it allows simultaneous use of various indicators (Bossel, 2001; Reed et al., 2005).

By suggesting subcategories within the division between reductionism and holism, various environmental accounting methods can be comprehensively reviewed in a more hierarchical manner. Below discussed are the developed indicators and tools.

2.2.1 Extensive methods (Non-system-based approach)

2.2.1.1 Single-criteria measures (SCMs)

Reductionist descriptions for the building system represent a large number of variables with a single metric. In this claim, a sustainability index is obtained in such a way that the whole system is disassembled into parts mechanistically. This framework supposes that the property of the system simply consists in that of subcomponents, i.e., a total exactly equals to the sum of the parts and vice versa; thus a system can be identified by exploring a small subgroup of entities or even a single compartment.

The selected media for data reduction help to display a clear vision of a system state, and judicious use of the tools during the design processes can facilitate reasonable decision-making. However, this perspective may lack detailed specification of various local circumstances of the system.

(1) Energy analysis

American Society of Heating and Air-Conditioning Engineers (ASHRAE) standard 90.1 defines energy such as “the capacity for doing work, it takes a number of forms that may be transformed from one into another such as thermal (heat), mechanical (work), electrical, and chemical (ASHRAE, 2013).” Energy analysis (EA) measures the amount of energy that a system requires to produce a specified good or service (Brown and Herendeen, 1996).

Currently, energy accounting forms the basis of many building sustainability

assessment methods including the credited standards (CIBSE, LEED, etc) and tools (EnergyPlus, IES-VE, eQuest, etc.). Theoretically, energy never disappears during all system processes, but only transforms into another forms. For example, one joule of heat is perfectly interchangeable with one joule of work, since it is based on the principle of “*thermal equivalency*” – the primary feature of the Newtonian paradigm – as the first law of thermodynamics (FLT), the law of conservation, supposes. It provides a very useful concept with which various forms of the system constituents can be evaluated on the same base. As Odum and Odum (1971) explain that energy is stored in the form of matter, materials and operational energies of buildings can be treated equivalently if they have the same joule of energy. As a result, energy illustrates a major limiting constraint for systematic phenomena (Kelly, 2011); i.e., energy measures are capable of providing a restriction on the gross energy usage that can be tracked though the partial amount.

However, the methods of assessing energy balance based on the conservation law do not bear any explanation on spontaneous processing of materials and products and their pathways. The energy equivalency, which perfectly meets the hegemony of mechanistic ideas that reductionism underlies, apparently downplays time and direction of the energy flows which are irreversible (Fernández-Galiano, 2000; Dincer and Cengel, 2001). Moran and Shapiro (2000) point out that the concept of energy flows is ill-suited to depict “significant aspects of energy source utilization”.

(2) *Exergy analysis*

Exergy was first coined in 1950s to characterize thermodynamic potential of energy – availability of heat that can be transformed to work, but the concept was introduced long ago as “free energy” by W. Gibbs.

Exergy analysis (ExA) measures the system’s maximum useful work, i.e., a rate of conversion of heat for effective use (work). While the concept of energy is that heat equals work, exergy does not. Even if energy is never destroyed during a process, the “usefulness” decreases according to thermal difference between the system and external conditions. System content of energy and matter are dissipated, degraded, and dispersed into the surrounding during any work process (Dincer and Cengel, 2001). Fernández-Galiano argues that exergy is the true author of all energetic phenomena (Fernández-Galiano, 2000). As Brown and Herendeen (1996) explain, EA

does not quantify an emission or absorption from or to the environment, energy primarily accounts for the heat transfer within the system. In contrast, exergy accounts are descriptions of the conversion process of energy according to the interactive relationship between the system and the environment.

Thermodynamically, exergy is a measure of “distance from thermal equilibrium (Jørgensen and H. Mejer, 1979).” If a system is in the equilibrium with the surrounding, exergy is zero. Thermal equilibrium refers to the state of the system with no heat exchanges to the external environment, which means death of the system. Accordingly, quality and value of the system, in terms of the energetic utility, depend on the distance. The longer the distance becomes, the higher the quality of energetic (heat) content goes up.

Shukuya (1994) introduced ExA to building study, and exergy has been widely utilized to measure the thermodynamic efficiency of building’s heating, ventilation, and air-conditioning systems (HVAC) or overall performance of building systems. Szargut et al (1988) proposed an extension of exergy analysis called cumulative exergy consumption (CExC) analysis. This method implements the total efficiency of energy carriers of natural resources.

Exergy is based on the second law of thermodynamics (SLT), and it is closely related to the concept of “*entropy*”. Unlike energy, entropy is not on casual perception. Entropy (S) is defined by change in heat content (Q) of a system divided by the system temperature (T), such that

$$\Delta S = \Delta Q / T \geq 0 \quad (2.2)$$

Eq. (2.2) is called the Clausius equality. Entropy always increases and entropy change (ΔS) is irreversible. ΔS becomes zero in the rare case of the reversible system.

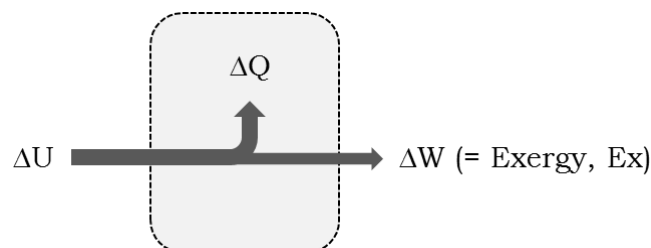

Fig. 2.3 Thermodynamic relationship of input energy (U), exergy (W) and internal heat (Q)

The correlation between exergy and entropy is identified with a simple example (Fig. 2.3). Given the external input energy (ΔU) to a system, by FLT, $\Delta U = \Delta Q + \Delta W$, where ΔQ is a finite increment of the internal heat content, and ΔW indicates the part of the input energy that participates into doing actual work. Introducing the energy conservation, Eq. (2.2) becomes,

$$T\Delta S = \Delta U - \Delta W \quad (2.3)$$

The amount of the useful work done is equivalent to exergy (Ex) of the system. Assuming no external energy is entered (spontaneous process), i.e., $\Delta U = 0$, finally we obtain,

$$\Delta Ex = -T\Delta S \leq 0 \quad (2.4)$$

Eq. (2.4) demonstrates that exergy varies inversely to entropy, and the fact that exergy increment is always less than or equal to zero reveals energy is always degraded accompanying the entropy increase in the natural process ($\Delta U = 0$) unless the positive amount of energy from the surrounding flows into the system.

Entropy (S) is the central concept for understanding the system status. It is a state function or a state variable at the same time, since it refers to accumulation of internal heat whose concentration leads to an ordered state of the system structure (Odum and Odum, 1971). Boltzman explained it as the number of possible quantum states, and formulated it as a function of probabilistic distribution of the energetic states. Entropy change can be used as a measure of intensive analysis. Due to the strong correlation between entropy and exergy as shown in Eq. (2.4), exergy might also be able to be categorized as an intensive measure. (Its implication is discussed with the statistical formulation in detail in Section 2.2.2 and Section 2.3).

Dincer and Cengel (2001) state that energy and matter in the universe can be rated with level of usefulness, Jørgensen (1992) argues “exergy illustrates pathways to create organization that move away from the thermodynamic equilibrium,” which leads to his ecological law of thermodynamic; we can characterize complexity and hierarchy of system from exergy levels. Entropy and exergy as thermodynamic measures will be discussed further in association with information theory and Odum’s

order and disorder model through Section 2.3 and Chapter 3.

(3) Embodied energy analysis (Input-Output analysis)

Embodied energy analysis (EEA) is also called Input-Output energy analysis. The objective of EEA is quite often energy cost-based economic planning and decision-making (Bullard et al, 1978; Burnakarn, 1998). Correspondingly, the target is to estimate the total energy consumption of manufacturing goods and services.

One of the key concepts to understand EEA is “net energy” (Bullard et al, 1978; Brown and Herendeen, 1996), since it aggregates various types of energy processing during the production of a unit of good and service into an energy input-output framework.

While EA measures consumption of energy sources at a specified time frame. EEA extends the time and scope on a energy flow chain to account for indirect energy and material inputs. However, care should be taken in the setting of the EEA boundary and conversion of indirect energy sources since the separation of energy from matter is improbable. Identification of the union of matter with energy with an appropriate conversion ratio is not easy.

(4) Emergy analysis

Emergy (spelled with an “m”) was developed by H.T. Odum in the early 1970s, to estimate solar embodied energy invested for producing goods and services. Emergy is “the available energy of one kind required to be used up previously, directly and indirectly, to generate the inputs for an energy transformation (Odum, 1996; Brown et al., 2004)”. Emergy is rooted in the concept of embodied exergy. It can be understood as an utmost extension of embodied energy, since it accumulates all kinds of direct/indirect energy flows stretched from the natural formation of materials. Specifically, similar to embodied energy, emergy is (i) process-based, and includes (ii) economic value and (iii) indirect effects of energy flow. Inspired by ExA, emergy is also concerned with quality of energy, and implicitly sums up all contributions of useful energy (exergy) inputs¹⁸ (Bastianoni et al., 2007) (EEA also acknowledges

¹⁸ In emergy theory, H.T. Odum distinguishes available energy and useful energy in definition.

different quality of energy sources, but it follows the energy conservation law in computation).

Energy-based energy flow accounting, called energy synthesis, and more formally energy analysis (EmA), traces the flows of the thermodynamic quantum (energy) within an analysis boundary. EmA underscores bookkeeping of all energy flows, and records the trajectories in its quantity.

Energy emphasizes the donor-side perspective rather than receiver based. i.e., similar to EA, Exergy, and EEA, energy aggregates upstream (inflow) impacts. While other extensive measures set an upper limit of processes so as to fit the goal of evaluation, energy locates it at the extreme capacity of global resources such as solar insolation, tidal flow, and deep earth heat that are eventually normalized in a single energy source—the sun. As a result, the measure of energy aggregates all type of energy into the equivalent solar energy, namely, solar emjoule (sej).

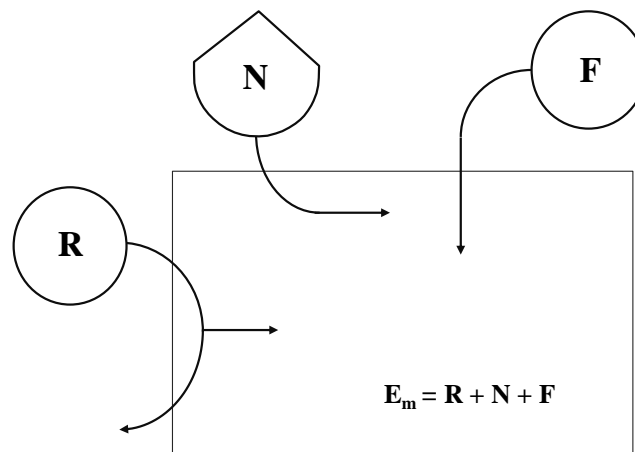

Fig. 2.4 Three major inputs in the energy analysis (Redrawn from Morandi et al., 2013). Abbreviations: E_m , Energy; F , purchased energy sources; R , renewable sources; N , non-renewable sources.

Unlike exergy-based analytical methods, EmA makes a clear distinction among energy sources (renewable, nonrenewable, and imported) (Kharrazi et al., 2014), and

Available energy is defined as “potential energy capable of doing work and being degraded in the process” (Odum, 1996; 1998), which is known as a synonym of *exergy*, and *useful energy* is an ‘actually’ used portion of the available energy for increasing system production. However, in many literatures, occasionally, the definitions are mixed. Available (potential) energy is generally appeared to imply both (Odum, 2007). Mellino et al.(2014) states that available energy can be identical to useful energy only when the reference state of environment is the standard laboratory condition for pressure and temperature.

proposes sustainability indices such as environmental loading ratio (ELR; $ELR = F+N/R$) and emergy yield ratio (EYR; $EYR = \text{emergy of products (Y)}/F$). Also from the ratio of ELR and EYR, EmA suggests a emergy sustainability index (ESI or SI), i.e., $ESI = EYR/ELR$ (Brown and Ulgiati, 1997).

Mathematically, due to the use of the common denominator (solar energy), every matter and energy has a specific emergy value, i.e., emergy intensity termed transformity (some literature uses unit emergy value (UEV; sej/unit quantity) to include the case of material inputs (Brown and Cohen, 2008)). Transformity is substantial to understand emergy. Transformity describes the quality of energy (a degree of energy concentration) and reveals the hierarchy of energy transformation, as Odum presented a series of cases from a small food chain to a large social structure for the demonstration of hierarchical system development (Odum, 1971; Odum and Odum, 1981; Odum, 1996; Tilley 2004). In a hierarchical chain, a system component with larger transformity (e.g. human information) takes one or more levels higher, governs larger supporting subsystems, and also has longer turnover time than one with lower transformity. In this sense, it is possible to suppose that an item/process with greater transformity has greater responsibility of environmental development, because greater investment of emergy is more likely.

Use of the emergy concept in the observation of systematic phenomena explains the ordering energy hierarchies, and inextricably reveals the following principles as to the fundamentals of ecosystem theory.

The ecological notion of self-organizing system is based on the hypotheses that all systems (e.g. living, human, cosmological, etc) develop specific forms of hierarchies ‘spontaneously’, and through trial and error, in such a way that all components constrain one another in selection of alternatives (Odum, 1996). It concerns shift of the system status that is driven by communication between system organization and external conditions. Odum (1988) demonstrates that given more available energy flows into a system, a network of the system structure evolves from simple linear to complex autocatalytic paths.

Maximum empower principle

Maximum empower principle (MePP) can be referred to as a principle of energy

transformation in system designs. Power is specifically defined as “rate of useful transformation of the available energy for each available energy source” (Odum, 1988) and represented with emergy per unit time. It suggests that all self-organizing systems evolve to utilize maximum available energy (emergy), and a system with higher empower thus prevails in competition with others.

This theorem begins with the Lotka’s law of maximum power in biological systems (Lotka, 1925). Odum (1988) points it out that it lacks (i) definition of human work and (ii) quantitative evaluation of different energy types, and, in turn, he proposed to use emergy instead of energy, contending “it is incorrect to use energy as a measure of work where more than one type of energy is concerned (Odum, 1988).” The maximum empower principle can be understood as an energy-quality sensitive maximum power principle. Boltzmann (1905) defines system development is “a struggle for free energy” (Jørgensen, 1992), and Jørgensen (1992) states an ecosystem with a higher level of exergy prevails.

The MePP clearly explains why and how a system develops, and Odum and Hall (1995) states that the empower principle and the hierarchical transformation rule are the fourth and fifth law of thermodynamics.

Odum (2007) contends that human affairs are also regulated by the energetic laws, MPP applies for explanation of civilization development. Let’s say a farmer plans to draw water from a well for irrigation. In the primitive stage, simply using a bucket, he or she would irrigate the soil efficiently with less energy invested in a short amount of time. But with a pumping machine installed, more volume of water (more available energy) can be supplied. Notice that maximum empower—a system’s full usable power is achieved when all system components develop feedback loops to amplify input sources. In this case, additional drainage pipelines will return gray water to the ground to be reused later as an underground water source. It will culminate in far more increased emergy flow per unit time.

H.T. Odum further demonstrated that 50% of input energy must be drained to sink, i.e., the intermediate efficiency, so as to reach the maximum power state (Odum, 2007). To be specific, in Fig. 2.5, a maximum output occurs at a trade-off point between speed and efficiency (Jørgensen et al., 2007). Let E_p denote potential energy of a heat reservoir, E_u be actual energy used to do work, and dt elapsed time to have the work done. Then, efficiency is given by E_u/E_p , and power (W) is E_u /dt . At the

point 1 on the left diagram, $E_u = E_p$, so, the efficiency becomes 100%, however, since $dt \rightarrow \infty$, and $W \rightarrow 0$. At the point 2, conversely, the work is done very fast. But no useful work is delivered ($E_u = 0$), hence, $W = 0$ as well. In the reality, the torque (power)-speed (*rpm*; i.e., rate) curve of a car engine shows the power is maximized at around 3000 ~ 4000*rpm* that is half of the maximum speed. The speed is inversely proportional to gas consumption (i.e., efficiency).

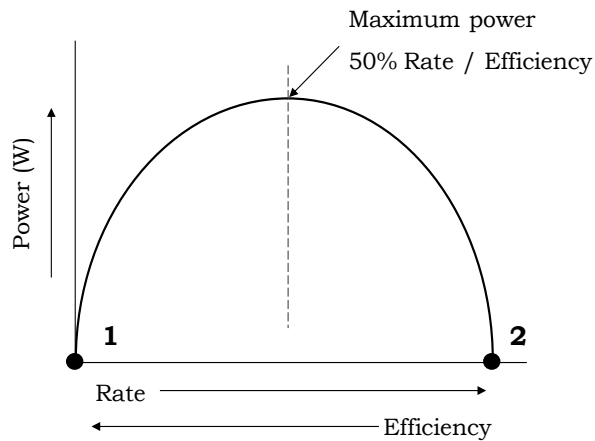

Fig. 2.5 Maximum power and efficiency

On the other hand, the MePP is mutually indispensable to the concept of self-organization, because the goal of self-organization is to facilitate maximized useful energy throughput.

In large built environment systems, particularly quasi-living systems such as cities or states, direct destinations and turnover time of feed-back loops of a network may not be observed in the reality. However, the self-organization towards maximum energy flows identifies the invisible reinforcement (Odum, 1988; Lee et al., 2013). Previous studies successfully find spatio-temporal hierarchies of energy flows in cities, landscape, and regional systems (Odum et al., 1995; Huang, et al. 2001; Abel, 2010; Lee et al, 2013). As for building systems also, Braham (2012) mentions “buildings are tools in a vast evolutionary process of self-organization”, and Braham and Yi (2014) substantiate that building production is a “formal cause¹⁹” of an energetic order of building components.

EmA, in fact, has been criticized from other environmental study disciplines

¹⁹ Ulanowicz, R.E., Ecology, the Ascendent Perspective, Columbia University Press, NewYork, NY, 1997.

mainly due to the uncertainty in the calculation of the global emergy baseline— annual total emergy input from the global sources to support the whole geobiosphere— and the specific emergy values. Ayres (1998) and Cleveland et al. (2000) doubt credibility of emergy models due to inaccuracy of emergy parameter values. To be specific, any particular EmA is measured relative to the emergy baseline, but the datum is quite uncertain. Odum (1996) gives 9.44×10^{24} *sej/yr* under the assumption that every source is independent, yet no one perfectly ensures that the three sources are not mutually dependent (Hau and Bakshi, 2004; Ulgiati et al., 2005)²⁰.

Moreover, if one were to strictly follow the emergy theorems, specific emergy values should be obtained case-by-case because even similar sorts of materials may not go through an identical process (Hau and Bakshi, 2004). It is, however, impossible to synthesize every different processing for every case of analysis and, consequently, EmA applies the same transformity for similar sorts of energy sources and matter. In spite of recent achievements for the baseline (Brown and Ulgiati, 2010), transformity data refinement (Brown and Buranakarn, 2003; Bastianoni et al., 2009), and uncertainty analysis (Campbell, 2003; Ingwersen, 2010; Hudson and Tilley, 2013), the questionable generalization on the baseline, insufficient data collection, and lack of quality assurance are still major barriers to deter its wider application into various fields.

Nevertheless, building emergy analysis (BEmA) is a valuable tool for building sustainability assessment, because (i) Emergy provides a ‘holistic’ indicator (from the receiver-side perspective), particularly bridging a site-specific local system and global energy resource flows and depletion, and (ii) Emergy evaluates all natural (renewable) sources as limited source. Meillaud and his team (2005) first attempted to measure building emergy use with a small building case. Pulselli et al. (2007) comprehensively analyzed whole building emergy consumption for manufacturing and operation. Srinivasan et al. (2012) pioneered new definition of zero energy building based on the maximum energy feedback concept. BEmA methods are constantly being evolved. Recent studies include a new methodology for emergy simulation (Yi et al., 2014), comparison of emergy and life cycle assessment (LCA) methods (Srinivasan et al., 2014), development LCA-based building emergy indicators (Reza et al., 2014), and a

²⁰ Intervention of the three sources (sun, tide, and geothermal heat) are considered in the maximum empower principle.

case study for an off-grid house (Rothrock, 2014).

Meanwhile, emergy reveals clear limits on the investigation of internal system states. Odum (1988) argues that different system behavior depends on different operating mechanisms, but he argues that the prediction of system performance is enough with including combinations and availabilities of external sources. The strength of systematic power, however, can fluctuate with time while in the development towards maximizing empower. He suggests pulsing as a general pattern observed during a self-organizing process (Brown et al, 2004). It is difficult to precisely expect and evaluate of the magnitude of power oscillation, and the I/O-based measure remains a limitation of EmA, because it may aggregate the multivariate aspects of system complexity. On top of this context, current BEmA methodologies do not fully elucidate the following questions for more comprehensive environmental building research.

(A) Lack of a full spectrum of illustration on receivers' response and ability.

(A)-1 The same quality of material (the same UEV) can exist in various kinds of building forms and energy processing. Suppose two building of the same energetic quality with the same amount of energy have different forms. The form affects the building energy use pattern in a different manner. Then, it remains questionable to answer how we evaluate the sustainability of building?

(A)-2 Lack of a threshold for drawing a system structure, and no focus on the strength of individual flow paths. For example, in an energy diagram, BEmA is descriptive of links between compartments. However, aggregation of multiple paths shows little or no difference in results. Provided a specific external environment change occurs, a code, like genes, to regulate a threshold and a preferred pattern of separate flow variation certainly exist in an embedded form of a receiver, but the emergy measure itself cannot detect it explicitly.

(B) Does it 'really' deal with energy quality?

Emergy is based on the concept of available energy, but does not directly calculate

the actual maximum work depending on the surrounding temperature in which the energy flows are generated. In many cases of BEmA applications, e.g., consuming fuels for building operation, energy is obtained by multiplication of given transformity and raw energy inflows, not exergy. Therefore, one may say BEmA does not accurately reflect thermodynamic irreversibility and energy loss during an energy transformation process (Zhou et al., 1996). This may also lead to domino-type uncertainty in all energy-based decision-making.

2.2.1.2 Summary and comparison of single-criteria measures (SCMs)

This section recaps the definition of SCMs and clarifies the difference and limit of each SCM by direct comparison. Technically, exergy is not a state variable, but it could be, since it is dependent on the system state change due to external conditions (Jørgensen, 1992; Zhou et al., 1996). So, if energy is “bookkeeper”, exergy is a “director” (Jørgensen, 1992).

Energy based analyses such as EA and ExA may discount the play of renewable energy and energy in small quantity (e.g., sunlight and human service). However, they are not free, and a service involving human body is a work of low quantity but high quality. Different quality of energy is acknowledged in ExA, but it only considers a narrow range of energy transformation (Odum, 1996).

Table 2.1 Comparison of SCMs

Method	Target	limit capacity	Transfer dir.	Efficiency
<i>EA</i>	net change	●	x	E_o/E_i
<i>ExA</i>	net negentropy net ‘useful’ energy (internal potential)	●	●	E_{x_o}/E_{x_i}
<i>EEA</i>	net energy	●	x	$\Sigma E_o/\Sigma E_i$
<i>EmA</i>	energy ‘flow’, accumulation of net ‘available’ energy	●	●	EYR

SCMs except for EmA neglect environment-supporting services that cannot be estimated in a common single unit (Zhang et al., 2010a). EmA overcomes such a problem, and highlight indirect impacts. Nonetheless, the point is, they all tend to

assume buildings as static systems, i.e., the systems are degraded through linear-static processes.

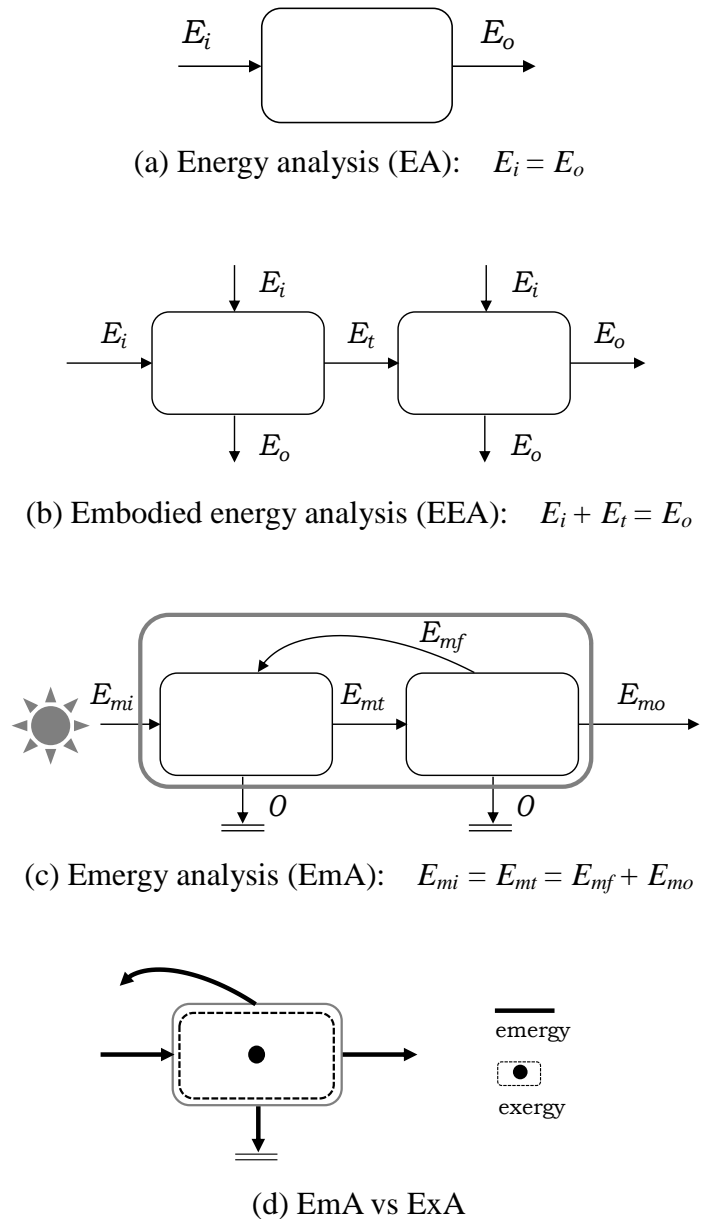

Fig. 2.6 Comparison of extensive analytic methods (E : energy, E_m : energy, i : input, o : output, t : transfer, f : feedback)

- EA and EEA focuses on the interchangeability of heat and work, and does not account for the energy quality.
- EmA primarily deals with ‘flow’ of energy as the Odum’s empower principle defines empower as the rate of energy delivery, but exergy concerns with the energy ‘fluxes’

of internal states of a component in the presence of the external energy exchange.

- It is at the first transmission process (E_{mi}) that the rate of energy inflow (empower) is measured to identify the maximum power principle (MPP). In the case of multiple first energy exchanges, each energy output of which must be evaluated (Cai et al, 2004), because MPP takes all the energy directly supplied from the source into account (occasionally, but not too often, in a complex system, it is hard to identify every input point, thus, a total of dissipated energy is measured instead (Odum, 1996)).

2.2.1.3 Multi-criteria measures (MCMs)

MCMs employ a comprehensive set of indicators to illustrate system behavior. Reductionism is an effective way to map complex phenomena around a system-specific domain into a universally applicable causality which contributes to the analysts' decision-making. But the problem is that the level of sophistication is limited due to its inherent top-down framework, and decisions based on a single objective as to selecting alternative processes may be misleading (Reed et al., 2005; Allen and Starr, 1982). In order to overcome the shortcoming, MCMs highlight to describe the diverse aspects of a system. Multi-criteria methodologies promote use of various individual indicators and interdisciplinary combination of the SCMs.

Life cycle Assessment (LCA) and hybrid indicators

In fact, LCA belongs to an intersectional area of SCMs and MCMs, depending on the evaluator's selection of energy delivery media and indices, since LCA focuses on scoping "phase"-based processes (generally, cradle-to-grave—i.e., production, use, and disposal), not development of a specified metric or an index. That is, life cycle of a building can be investigated with various terms such as physical energy units, monetary and cost units, or social effects based on the I/O analysis (Bekker, 1982).

LCA standards prescribe four steps for analysis, namely, goal and scope definition, life cycle inventory analysis (LCI), life cycle impact assessment (LCIA), and interpretation. LCA targets an evaluation of full range of environmental impact during an industrial process, and it highlights both upstream and downstream impact (Raugei et al., 2014). The upstream impact is primarily assessed by life cycle energy analysis (LCEA) (Fay, 2000) that aims to accounts for all energy inputs invested at every stage,

aggregating them using a single energy unit (Joule or Watt), whereas LCIA employs carbon dioxide (CO₂) equivalent to estimate all downstream waste (e.g., green house gas emission, water-borne pollutants, etc.). The two different directions are complementary to each other.

Even though the need of LCA is strongly underpinned by the stage-based chain of resource circulation, it is fundamentally based on the I-O analytical framework. So, industrial manufacturers can estimate consequence of decision-making, and LCA reports are used to improve environmental performance of the process such as reducing input sources, emission of pollutants and waste (Buranakarn, 1998).

Indication of each reductionist measure is inherently restricted to a system boundary and its unit bounds up with the sort of quantum of the processing flows (Fig. 2.6). Therefore, many studies attempt to synthesize and integrate SCMs with LCA, orchestrating the advantages of each SCM to fit specific objectives of evaluation. The multi-disciplinary compositions are developed to new MCMs frameworks and hybrid measures. Examples are energy-based LCA (Ingwersen, 2011; Raugei et al., 2014; Reza et al., 2014) such as ECO-LCA (Zhang et al., 2010b), exergetic LCA (Cornelissen and Hirs, 1997) or LCA-based exergy based on the cumulative exergy consumption (CExC) (Liu et al., 2010), and Life cycle energy analysis (LCEA) (Cabeza et al., 2014).

Hau and Bakshi (2004) attempted to expand exergy analysis to include ecological processes. Ukidwe and Bakshi (2005) propose thermodynamic input-output (TIO) analysis as an extension of the traditional CExC approach so as to integrate ecological and human sectors with industrial processes. They used monetary flows and global exergy inputs as well as the EmA indices to deal with the comprehensive aspect of the economic-ecological-social (EES) system.

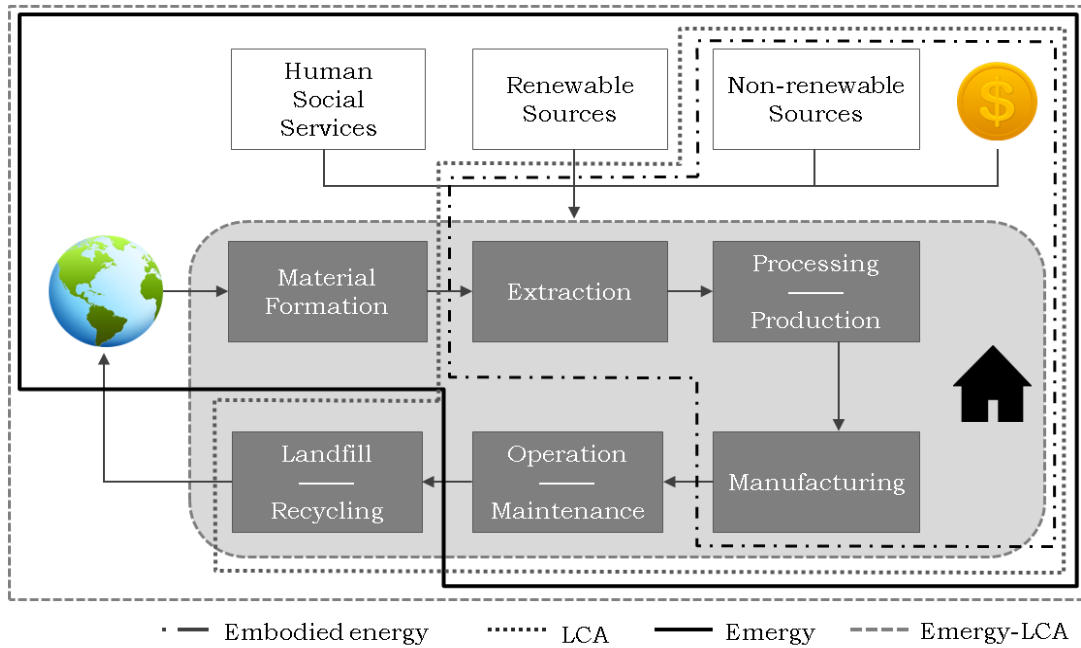

Fig. 2.7 The whole extensive process of the building system and the scopes of the reductionist methods based on the traditional concept of each SCM (EEA and LCA could include a renewable input but cannot evaluate the value as a limited environmental source.)

2.2.2 Intensive methods: System-based complexity measures

The methods and tools presented in Section 2.2.1 decode Eq. (2.1) in terms of the full reductionist and the quasi-reductionist perspectives. They employ aggregated indicators to measure depletion of material and energy resources, and evaluate the system efficiency based on the input-output framework. As an occasion arises, a building is sectioned off into the individual subset of elements such as structure materials, HVAC systems, glazing, interior furniture, and so forth. Then, a summation of the energy carriers accounts for the whole building system performance.

However, despite the wealth of knowledge from the reductionist tools on the overall building system performance, they do not provide much useful insight into the internal organization of and interactions between the individual elements, or the mutual relations between each phase of the building life cycle. Jørgensen (1992) points out that (i) “a direct overview of the many processes that work simultaneously is not possible, (ii) the interaction of all processes and components are contingent, and

(iii) the conditions determined by the external factors keep changing.” Specifically, the building extensive measures primarily consider quantity of throughput of the energetic structure. The concept of exergy and emergy informs the qualitative aspects of energy equivalency and illustrates the hierarchical context of building energy use (direction of the flows from high quality to low quantity), but it does not render a clear vision as to how the system constituents are integrated to adjust capacity and efficiency. i.e., reductionist methodologies underestimate organizational complexity of the building systems internal structure, which is implicit, or even invisible, but clearly influential to the ability of energy intake and processing (Eq. (1)).

A building is more than a mechanical assembly. It is analogous to an organic body that cannot be fully described without investigation on the internal metabolism. As Grumbine (1994) finds that monitoring ecosystems metabolism should focus on (i) ecological boundaries, (ii) degree of integrity, (iii) local context, (iv) inter-agency cooperation, and (v) organizational change (Czech and Krausman, 1997), building analysis needs to explore new indicators to identify those factors.

Based on these backgrounds, methods and indicators for intensive analysis are from the system-based approach. Intensive measures concern the degree of system organization, opposing the reductionist claims. It is based on the modern systems theory, and aims at taking closer look at internal variations among systems, subsystems, and components. Intensive analysis has not yet been introduced to environmental building research, yet adaptation of information theory is not new in the literature. It has been studied earlier in the field of system ecology (synecology), and emerging in other disciplines such as urbanism, city planning, regional policy studies, environmental management, and economics.

The following subsections introduce the theoretical backgrounds and discuss applications to the ecosystem and other disciplines.

2.2.2.1 Information theory and Shannon index

Thermodynamic entropy and Boltzmann equation

Methodological development of the system-based complexity analysis that is currently used for a broad spectrum of interests is indebted to the rise of modern physics based on probability theories (especially, statistical mechanics and quantum

theory). At first glance, physics seems to have little to do with other fields directly, but the revolutionary idea that a system state perceptible at human scale can be explained by the system's microscopic network is derived from physicists' persistent endeavor that opposes to the idea that heat is indestructible regardless of the system content.

The first attempt to quantify the inner state of a system was made by a group of theoretical physicists in the mid 1800s. In explaining behaviors of mechanical systems in terms of the thermodynamic laws, what they noticed was that knowledge of the general thermodynamic properties (e.g. energy, pressure, temperature) of the system was not fully insightful to and not necessarily consistent with that of atomic-level attributes (e.g. molecular kinetics, chemical composition of a particle). This discrepancy had been noted earlier by D. Bernoulli and S. Carnot who had recognized that energy was a motion of granular particles, and vibration of the molecular structure generated heat (Brillouin, 1961).

It was clarified that the observation of macroscale properties that was explained by the Newtonian mechanics involved with a great deal of uncertainty in terms of the microstates of the system, and which served as an incentive that the classical mechanics was integrated with probability theorems.

In the course of the transitional moments, Ludwig von Boltzmann (1886) is the most responsible for describing the second law of thermodynamics, which applies to every state of the universe as a whole, in probabilistic accounts. Boltzmann thought the thermodynamic property of entropy could be approximated by the statistical measure of number of possible molecular or atomic states.

To be specific, if energy is the outcome of molecular vibration as supposed, there need a small part of total molecules to be active in a high-entropy system (i.e. a macrostate in large amount of unavailable energy). Accordingly, one may observe variety of discrete combinations of the individual particle to participate the given energetic state. In other words, a large number of micro thermodynamic states can be chosen under a macrostate.

For an equilibrium system, entropy (S) or Boltzmann entropy is defined as a logarithm of probable microstates, Ω ;

$$S = k_b \log \Omega \quad (2.5)$$

where k_b is Boltzmann constant (1.38×10^{-23} J/K), and Ω denotes the number of cases

of microstates corresponding to the macroscopic state of the system. Then, S is the entropy of a system thermodynamic state at a macro scale.

Compared to the Clausius's formulation (Eq. (2.2)), the above formula establishes an innovative way of measuring thermodynamic entropy. Eq. (2.5) can be rewritten in the classical form as,

$$S = -k_b \log \frac{1}{\Omega} = -k_b \log P \quad (2.6)$$

Now, we obtain a clearer picture of the relationship between probability of macro states (P) and the macroscopic attribute of a system process (S). Based on this idea, entropy corresponds to a degree of variability or freedom of choice in a deterministic observation that can be finally compiled to balance of the internal complexity. For instance, if every system particle (quantum) is presumed to be available for heat generation, choice of the particle combination must be unique. Therefore, probability (P) to represent this state becomes 1, bring on minimum entropy ($S=0$), which is actually unprobable in the reality.

Meanwhile, it should be noted that this statistical entropy theorem was induced by Boltzmann's experimentation with ideal gas, and is premised on the independence of each particle. If particles interact one another, system states could be unpredictable from the combination of individual particles, because even a single particular combination can have a wide range of energetic states (Jørgensen, 1992).

Shannon information (Shannon index)

Harry Nyquist (1924) first demonstrated that a large source of communication inputs can be defined as the logarithm of the possible sequences of input signs. After him, Shannon (1948) developed the concept of information or information entropy to calculate the capacity of signal transmission in telegraph communication. The simplest system of delivering telegraphic messages consists of an information source producing messages, a receiver as a terminal, and a channel as the medium used to transmit signals (Shannon, 1948). This theory basically intends to identify how many bits are required for the signal delivery to a destination. Note that it has nothing to do

with what the contents stand for. For example, when one sends a symbolic message such as ABA|ABA on 2-bit basis, he or she must set the limit of the capacity to not less than 64 bits (2^6) for proper operation in noiseless environment. If the first two characters (AB) were fixed, the capacity is reduced to 16 bits (2^4). Those results can be expressed in logarithm such that $6 = \log_2 64$ and $4 = \log_2 16$. One may easily notice that the form of expression is quite similar to that of the Boltzmann equation. If we let p_i denote the frequency of a target signal measured on the i -th of n channels, the information entropy (H) of the channel system and the probability (p_i) are related such that $p^H = p_1 p_2 \dots p_n$, assuming that each channel is independent. This leads to Shannon's major theorems. Let's say we have several compartments (transmitter) within a simple flow graph, and then information entropy or Shannon index is given by:

$$\begin{aligned}
 H &= k \left(p_1 \log \frac{1}{p_1} + p_2 \log \frac{1}{p_2} + \dots + p_n \log \frac{1}{p_n} \right) \\
 &= -k \sum_{i=1}^n p_i \log (p_i) \quad (2.7)
 \end{aligned}$$

where k is a positive constant that amounts to unit selection (it is usually set to be 1), n is the number of total channels. Negative sign means information is inversely proportional to the number of possible signal occurrence.

The general expression of Eq. (2.7) for continuous variables is²¹

$$H = -k \int p(x) \log p(x) dx \quad (2.8)$$

For Shannon index, common bases are 2 and e , or sometimes 10, and the selection of the bases does not critically affect the information value. When 2 is used for the logarithm, the unit of information is *bit* (binary digits). When 10 is used, then it is termed *dit* (decimal digits; Shannon, 1948) or *hartley*. For the natural logarithm, the unit information is called *nit* (natural unit) or *nat*.

²¹ However, the continuous form cannot be directly derived from passing the discrete expression (Eq (2.7)) to the limit. (see Appedices)

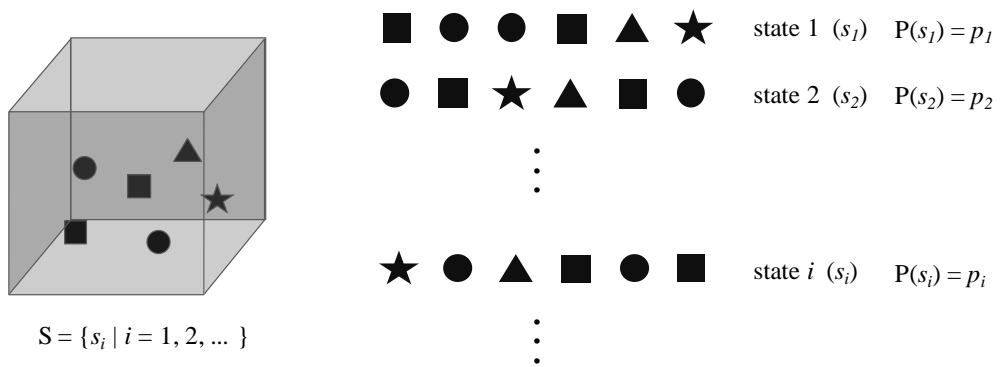

(a) Concept of information entropy

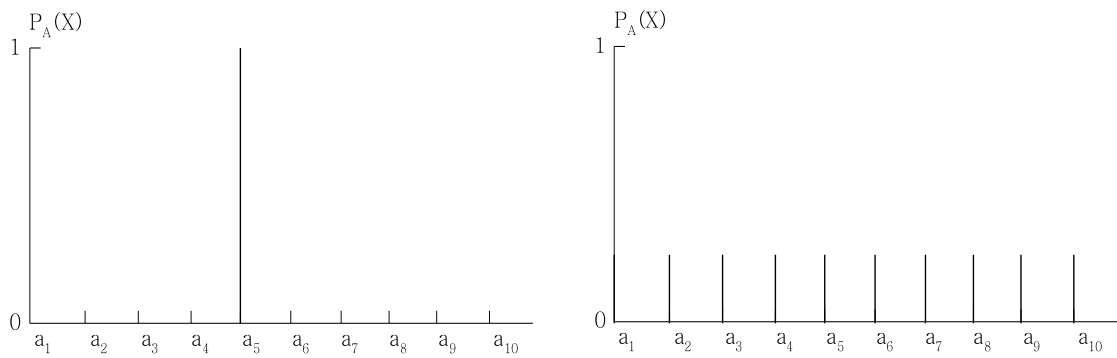

(b) Shannon information becomes zero (left), and reaches the maximum (right)

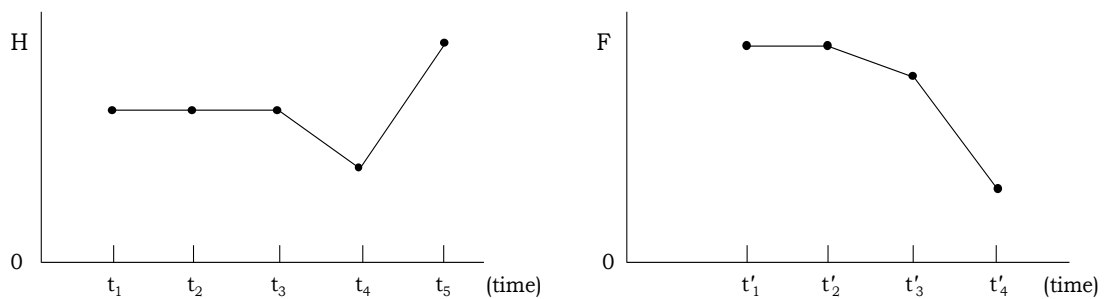

(c) Hypothetical profile of Fisher information variation given Shannon information (left) for a time-series dataset

Fig. 2.8 Concept of Shannon information and Fisher information

2.2.2.2 Kullback–Leibler information

Kullback-Leibler information (KL-divergence; D_{KL}) is also called relative entropy or information gain. It evaluates the extra information required to estimate a true probability distribution P (e.g., true values or observed data) with a hypothetical distribution Q (e.g., theoretical probability function). KL divergence is closely related

to Bayesian inference because it represents a degree of uncertainty in the approximation of P given a prior distribution Q. The following equation computes the KL divergence:

$$D_{KL}(p||q) = \sum_i p(x) \log \frac{p(x)}{q(x)} = H(P, Q) - H(P) \quad (2.9)$$

2.2.2.3 Fisher information: A local index of system behavior

MacArthur (1955) introduced information theory to ecology. Replacing p_i of Eq. (2.7) with a fraction of species number in an ecological web, he used Shannon information as a stability indicator of a trophic structure.

Shannon information successfully aggregates a degree of ‘equitability’ and ‘variety’ of a given data set into one index (Odum, 1969). However, the matter is, it does not depend on the sequence of the data collection (e.g. in Fig 2.7 (a), the order of the individual distributions has nothing to do with the final value. Switching a_5 and a_6 , to make $P(a_5) = 0$ and $P(a_6) = 1$, ends up with none of information content as one expected), because the Shannon index finds its purpose in representation of ‘average’ indeterminacy (degree of freedom) of a unit medium of a system in a certain state. It follows that it cannot account for the variation of ordering of system components (Fath et al, 2003; Eason and Cabezas, 2012). If attribute and order of compartments are constant, it will always give the same information regardless of the ordering. In the case of which we could ensure that any variables do not counteract one another, emphasizing the averaged aspect of a particular system observation (for this reason, Brian D. Fath and his team (Fath et al., 2003) assert to call Shannon index a “global” property of a system), in a way, is advantageous especially in terms of its capability of measuring information changes that are not affected by adjustment of data arrangement.

However, real ecosystems tend to move away from equilibrium during developmental stages. In the course of the movement, external perturbations agitate, either radically or moderately, an organization of the system so that it is occasionally driven into an unexpected extraordinary state. Such transition is occurring through time— a universal independent variable, and, therefore, Shannon information that is a

static measure does not help studies whose focus is on the unusual paradigm shifts of a system.

For that matter, in an effort to monitor sequential variations of system components in a dynamic manner, an alternative indicator²², Fisher information, is employed to detect the re-ordering of an internal organization without change of probability values.

Fisher-information

Fisher information (named after the statistician Ronald Fisher) is defined as the variance of the expected values of observed distributions. Mathematically, from Eq. (2.7), if the parameter θ is non-random, Fisher-information is formulated as,

$$F(X|\theta) = \int_x \frac{1}{p(x|\theta)} \left[\frac{\partial}{\partial \theta} p(x|\theta) \right]^2 dx \quad (2.9)$$

where θ denotes a random parameter of the random variable x .

$$X = \{x_1, x_2, \dots, x_i, \dots\}.$$

If the probability of the prototypical trial X , $p(x)$, varies with a certain regularity organized by the parameter of interest θ . This is not a function of a particular observation, but implies a continuous description of dynamic system behaviors.

Suppose one seeks to track of regime (state) changes with the strength quantified. In this case, the system variable x that characterizes system states can be imposed over a time-based system trajectory. Let the trajectory be a vector S . Subdividing the path into several segments so that each includes major transformation of microstate changes, we represent S as a set of segment vectors i.e., $S = \{s_1, s_2, \dots, s_i, \dots\}$. Now, the system variables (x_i) can be grouped to occupy a state of a certain time period (s_i), and, then, the independent system variable of Fisher information is substituted with the state variable s . This process turns the original form (Eq. (2.9)) into a new formula as below,

²² Another information indicator is Gini-simpson information, $G = 1 - \sum_{i=1}^n (p_i)^2$, which is unpopular, and has not yet been introduced to environmental study. Similar to Shannon index, it also sets limit on detection of global system change.

$$F(s) = \int_s \left[\frac{d}{ds} p(s) \right]^2 \frac{ds}{p(s)} \quad (2.10)$$

which substituting $p(x)$ with $p(s)$ yields the likelihood that one observes the system being in a particular state s . Notice that Eq. (2.10) uses the derivative term $dp(s)/ds$, which means Fisher information is proportional to the rate of distribution change. If the system stays longer within a particular state, Fisher information goes up for that period of time. Therefore, it follows that Fisher information is a measure of ‘*invariability*’ of local system states (Karunanithi et al., 2008). Meanwhile, for practical applications, it is necessary to transform Eq. (2.10) into an expression for discrete variables because most natural phenomena are discretely perceived.

It is important to distinguish what Shannon and Fisher information mean to measure respectively in terms of the theoretical implication as well as practical purpose. Suppose the shape of the density function $p(s)$ is flat, then the overall system state is extremely unstable. Accordingly, information required to identify individual states is huge, and the Shannon index should be the maximum. However, what about Fisher information? $dp(s)/ds$ approaches zero, and, therefore, nothing is given to Fisher information. What do these results imply?

As discussed earlier, system organizations keep changing, whether it is on a small or large scale, and the order and pattern of the change always occurs on a time basis. At this point, Shannon information attempts to describe the status quo from the macroscopic viewpoint, just as statistical entropy (Eq. (2.5)) defines the energy systems. Accordingly, Shannon information is effective to examining how distant the observed state of the system is away from equilibrium (maximum entropy). Fisher information concerns the history of the state variation within the observed range of time. Shannon index could be time-sensitive by tracing a sequence of numerical quantities distributed on a time axis, but Fisher information basically always requires time-series data.

Shannon and Fisher information are not opposed to each other, but illuminate different sides of the same event for different questions. Shannon index tends to be associated with the concept of homogeneity, diversity, or capacity, whereas Fisher information is used as an indicator of regime change (Fath et al., 2003), of the system

moving away from usual fluctuation, and it quantifies the degree of vulnerability and the homeostasis of the organization.

2.3 Information entropy, thermodynamics, and applications to environmental studies

Boltzmann linked the entropy of mechanical systems with stochastic configuration of the internal states (Section 1.2.3 and 2.2.2.1), entropy is the central concept in the development of statistical mechanics and it also has been understood as an iconic name of the network complexity measure.

As soon as Shannon generalized entropy under the context of communication (Shannon, 1948; Tribus and McIrvine, 1971), non-physicists became aware of its universal applicability. Simultaneously, inspired by thermodynamic laws, the measure of entropy and energy degradation spread widely to characterize various processes of multiscale systems (e.g. geographical, social, economical, and biological systems) far beyond the investigation of mechanical systems. Using thermodynamic accounts, we are capable of explicating the energetic states of a system that are indeed segmented according to our interest from nature; thus it does not seem strange that different areas of study have implemented it to identify systematic problems of their own fields.

However, the bottom line is that entropy is meant to be a thermodynamic term that is consistent with the classic mechanics (In this dissertation, *entropy* only refers to thermodynamic entropy of Clausius and Boltzmann. Use of *information entropy* is restricted to refer to the indices derived from the Shannon index or Fisher information for the clarity of terminology use). Accordingly, we need to draw a sharp line between the metaphorical adaptation and applications from the genuine definition of entropy to avoid intellectual confusion, since it is too often employed indiscreetly, and occasionally abused to some extent in various contexts and research fields of different culture. Even if the law of entropy must be self-evident in all disciplines, expanding the use of the term outside the scientific terrain without delving into the thermodynamic postulates and empirical evidences risk lending itself to misinterpretations. The relationship between information entropy and entropy is still open to debate. Nevertheless, as Jørgensen(1992) asserts, information entropy and thermodynamic entropy are seemingly analogous but not the same, it is certain that information entropy is not exactly the same as that of thermodynamics for chemical

reaction, microscopic free-energy change, molecular binding, etc²³. Therefore, critical scrutiny should be given to ambiguous and misleading distinction about (1) information (entropy) and (thermodynamic) entropy, and (2) entropy and disorder. It is because the concept of entropy and its theorem are adapted in different fields with different models for which they are designed. The following sections clarify the definitions that can invoke constructive discourse of building sustainability. To this end, along with a review on previous studies, applications of information and entropy are examined for the development of the methodology in this dissertation.

2.3.1 Information entropy and thermodynamics

The technical definition of information based on entropy has been organized since the anthropocentric interaction of a system mechanism began to draw the modern system theorists' attention. Based on the fact that every system process is connected to the outside world²⁴, information can be conceptualized as “a measurable but invisible body corresponding to the outside context” that is transferred through system processing to maintain a desired mechanism (whether or not it is deterministic or self-governing). In this sense, Wiener(1948) enunciated information becomes “time-dependent” and shapes a “vital structure.” In the way that the information content flows along substantial network paths, its behavior is similar to quantum of energy and matter (Fig. 2.8). However, recalling that the external intelligence provided for the system adjusts the distribution of energy and matter, it is appropriate to regard information as a more generic concept than other two elements. And at this point, information tends to be analogous to thermodynamic entropy in such a way that both are the index of probability assignment of matter and energy. Meanwhile, as explained in Section 1.2.3, information has double nature in interpretation: (i) any form of knowledge delivered to a system (e.g. human language, signal, numeric data, genetic code, etc.) and (ii) a measure of network complexity based on mathematical

²³ Warning about the popularity of information theory beyond communication problems, Shannon highlights that “the hard core of information theory is, essentially, a branch of mathematics, a strictly deductive system (Shannon, 1956).” His apprehension is also shared by Chapman (1970)'s statement that “without a temperature constant entropy in information theory defines a property of an equation and not the inevitable state of a closed thermodynamic system (Ayeni, 1976).”

²⁴ Note that measure of thermodynamic entropy is applied to the analysis of both isolated and non-isolated systems, but information is always premise the system being under study is open.

reductivism. However, this differentiation may not be contradictory or dissimilar in the context of system evaluation, because the system analysts aimed at integrating mechanical systems with human intelligence by quantification of information content. Wiener was aware of this problem, and he embraced the different implications in a single definition of information²⁵, (i) “the knowledge of all positions and momentum at any moment” and (ii) “the number of decisions to be made for system processing (Wiener, 1948)” for the semantic definition. His idea is supported by the Ulanowicz’s statement that information is “anything that constraints the system elements so as to change their probability assignments (Ulanowicz, 1997).” Either way, this framing identifies information as an extension of thermodynamic entropy in similar situations (Wiener, 1948). However, campaigns of information theory associated with entropy cannot be undoubtedly justified because Boltzmann entropy is a measure of atomic organization of ‘energy’ which is directly germane to the classical thermodynamic laws. On the other hand, information entropy that incorporates any kinds of media in its formulation may not strictly follow the law of entropy. Thus, in this light, Jaynes (1957) mentions that thermodynamic entropy is a subset of information entropy (Fig. 2.9).

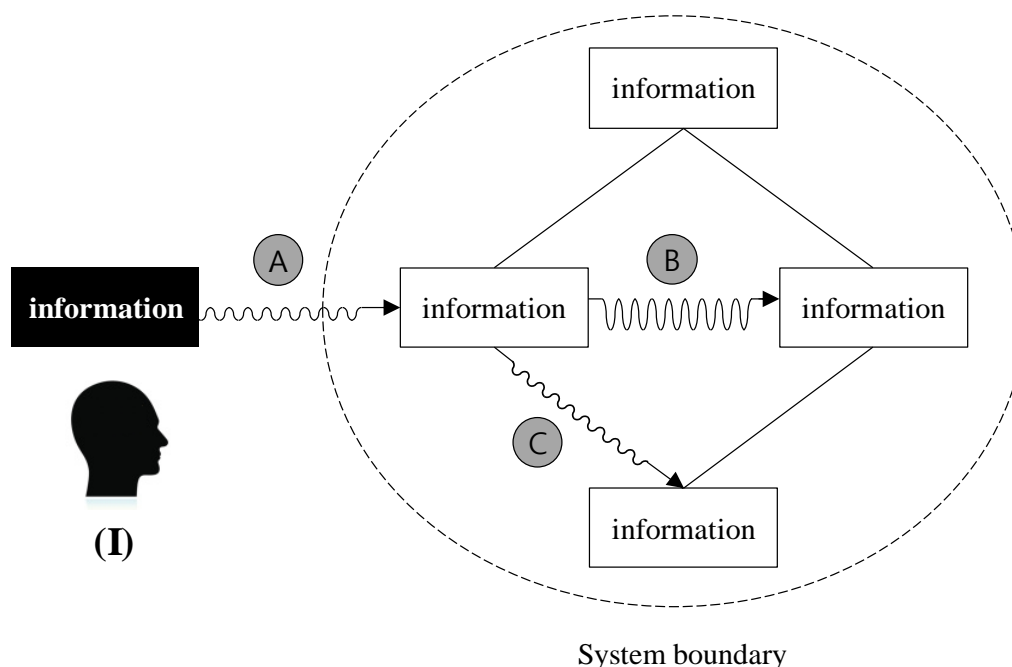

Fig. 2.9 Transformation of the semantic level of information (knowledge)

²⁵ <http://www.informationphilosopher.com/solutions/scientists/brillouin>

into the syntactic structure: External information (I) is transmitted into the system's internal network whose subcomponents, likewise, consists of energy, matter, and information. The external information is delivered through some of the network channels in a direct manner (B,C). While in transfer, information does not spread homogenously. The information content can be augmented (B) or even faded. As a result, it induces (1) internal resonance of the system structure (2) a set of network instances. Any of which could be an object of analyst's measurement, namely, evaluation of semantic information content dissolved in the structure of the system network.

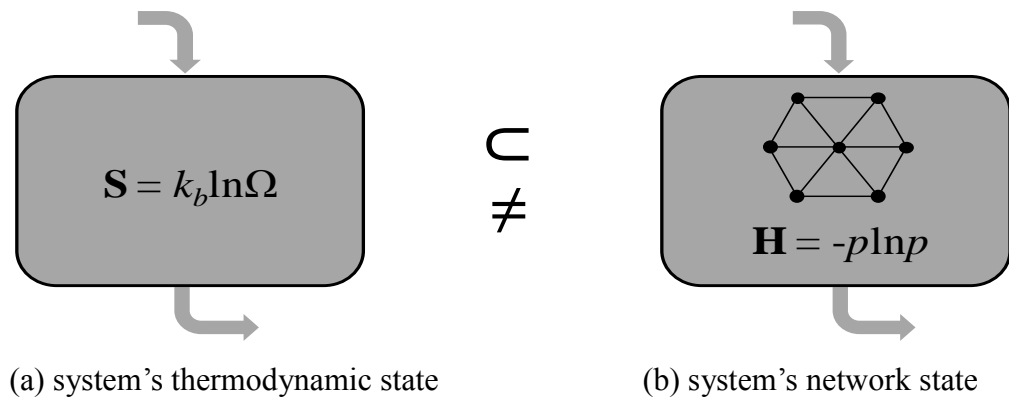

Fig. 2.10 Intent and limit of the analogy in quantification: Information entropy (H) could be understood as a generalization of the notion of thermodynamic entropy (S). However, during this remarkable moment of analogical transition, the measure of information entropy is away from the direct link with thermodynamic principles.

Wiener's first categorization deals with the methodology of quantifying information. It implies that any external signal acts as a stimulus to affect change in the system's internal organization to some degree. For example, let's say a driver is going to accelerate a car. He or she would step on the gas pedal, and the pressure applied to the pedal switches on the spark, and the driving power generated from the engine is transmitted through the gearbox and shafts to the wheels. Elements of the vehicle driving system operate selectively, which changes the configuration of the organization of active components. The driver does not touch any of internal elements other than the accelerator, and does not know any details of the principle of motion. However, the whole system has been manipulated at will by introduction of the information the driver possesses. Therefore, this case can be generalized to suggest that variations of system networking are a surrogate of human knowledge (information) that the system obtains.

The second categorization is more directly related to measurement techniques.

However, as Batty (1974) points out, there are two different theoretical roots that confuse the choice of information measurement. One originates in Shannon's theory (1948) and another derives from the idea of Wiener (1948) and Brillouin (1961). It is a common ground that both understand information as the number of observer's decisions (particularly, that of binary choice) regarding system manipulation, but the derivation process and implication are quite different. First, as seen in Eq. (2.6) and (2.7), the main fuel that connects entropy to information theory is the similarity of the formulaic expression. Shannon's equation describes nothing more than a degree of the unpredictability of data. Nevertheless, he insisted on calling information entropy, and definitely suggested the index of uncertainty as a measure of information. However, note again that the focus of the Shannon index is different from entropy in physics. Misinterpretation primarily lies in the translation of entropy (S) to the carrying capacity of signal (H). It could be employed to measure entropic phenomena, but has no direct implications for thermodynamic actions (Fig. 2.9). In other words, information entropy is a mathematical expression that was developed to describe non-thermodynamic content. As a result, information entropy has no absolute reference value. (it be indexed to H maximized, but it is not invariable.) However, thermodynamic entropy is always estimated from the reference state (S_0) of absolute zero ($T = 0\text{K}$), where entropy becomes zero ($S_0=0$).²⁶ Therefore, empirical justification is required when information entropy is applied to represent the states of a system, even though any system in the universe must be under the law of entropy.

In this context, Thims (2012) argues that Shannon-based thermodynamic "campaign" —information entropy— has nothing to do with entropy, and that information entropy does not correlate rigorously to thermodynamic issues, thereby conclusively suggesting to call Shannon index (H) "*bitropy*" (Thims, 2012). Jørgensen (1992) insists it must be flawed if H is interpreted as the actual information we have. He states that H is an amount of information that needs to be acquired to fully identify the microstates of a system.²⁷ Meanwhile, the calibration of information proposed by Wiener and Brillouin is more related to the interpretation of biological communication processes in the context of a mechanical automation, i.e., estimation of man's

²⁶ So, in fact, **Eq. (2.5)** implies the expansion including the reference state

such that $S = S - S_0 = S - 0 = k_b \log \Omega - k_b \log 1$

²⁷ A study argues that inclusion of time is the critical difference between entropy and information entropy (<https://sites.google.com/site/markovchainuniverse/understanding-information-and-thermodynamics/information-entropy-vs-thermodynamic-entropy>. Accessed September 18, 2014)

knowledge supplied to activate the system operation (one can notice that this is the method of quantification directly motivated by the Wiener's first categorization of the information definition). To this end, Brillouin (1949), who first infused Wiener's cybernetics into physics, attempted to generalize the principle of irreversibility and entropy increase to the process of (human) 'thought'. He assumed, in a system process, a change of entropy corresponds to that of information (e.g. observer's input of light beam to investigate a dark object changes its quantum structure, i.e., change of entropy(S)), and finally argued that it is "negentropy", the negative of entropy, which is translated to the ability to produce work, which represents information. For this formulation, information (I) can be written as,

$$I_B = NE = S_1 - S_2 = -\Delta S \quad (2.11)$$

where NE denotes negentropy, S_2 is entropy of the observed state, S_1 is entropy of the reference state, and ΔS is total entropy change. In the Brillouin's theorem, there are two points that claim our attention. First, he expanded entropy to the notion of the "value" of other phenomena, and, no matter what the content is, the value is determined relative to the surrounding conditions, as heat of the same quantity has different entropy according to the ambient temperature. Second, unlike Shannon information, Brillouin information (Eq. (2.11)) presumes entropy of a certain state (S_2) degenerates from a reference state entropy (S_1). In this case, the reference state is not necessarily absolute zero. S_1 can be an initial entropy before observation. Because of the two features, Brillouin's negentropy theorem is far more consistent with the physical and thermodynamic principles than the Shannon index. He addresses the fact that every observation consumes information with coupling of a man and observations in a physical experiment. If a man observes a stem that transits from state 1 to state 2, the observer must invest knowledge to identify a system state into the system. The knowledge is an energetic work of the brain in useful work. Therefore, information supplied by the observer to read the observed system is negentropy, in other word, negentropy must be inputted to extract useful data (information) from a system under study. As a complex system require a large amount of information, information becomes a complexity measure²⁸.

²⁸ For example, think of a paper with full of a single letter 'A' and a newspaper article. Suppose a man

This progressive idea influenced researchers of other fields (Marchand, 1970; Landauer, 1991; Jørgensen, 1992), particularly a group of ecologists who dealt with information in terms of accumulation of genetic data. To integrate the Brillouin's idea with the Shannon index, they set a reference as an equally probable state which is analogous to thermodynamic equilibrium. Then, observed information entropy is counted from the reference, which gives a new definition of information using Shannon index. This is given by

$$I = H_{max} - H \quad (2.12)$$

where I is (obtained) information, H_{max} is maximum Shannon index, and H is observed Shannon index. H_{max} is always greater than H . This equation indicates that an entropy increase (increase of Shannon index, H) results in a loss of information (I).

In this equation, the formulaic similarity strongly implies that an observer's information gain corresponds to relative entropy (KL-divergence). Thus, I is a potential measure of information gain which becomes a possession of the observer immediately after observation. In other words, it can be understood in a way that I (and I_B) is the knowledge of how much the observed system is structured, namely, degree of organization. In contrast, Shannon information (H) can be referred to as the description of unstructured parts (Fig. 2.10).

Compared to Eq. (2.11), Eq. (2.12) is still flawed because of the equivalence of the Shannon index (H) and thermodynamic microstates (S).²⁹ Nevertheless, many studies following Brillouin's approach name information as I , and adopt H as system entropy. The reversed relation is used to characterize the relationship of information and entropy (Marchand, 1972; Jørgensen, 1992; Balocco and Grazzini, 2006).

Note that H and F are descriptions of the system itself. Information quantifies various aspects of complexity. Moreover, in the semantic sense that man's knowledge is related to something that we know, it is more natural to call the information measure estimated from Eq. (2.12) information. H and F are more appropriate to

would read them. Which one requires less time to read? (not understanding) Absolutely, the former. This indicates that the work with complicated words, which actually tends to deliver much more information contents to the reader, needs far more knowledge to read—higher level of information.

²⁹ Layzer (1976), Books et al. (1989), and Jørgensen (1992) state that H corresponds to entropy of the ecosystem.

describe the system's unstructured instance.

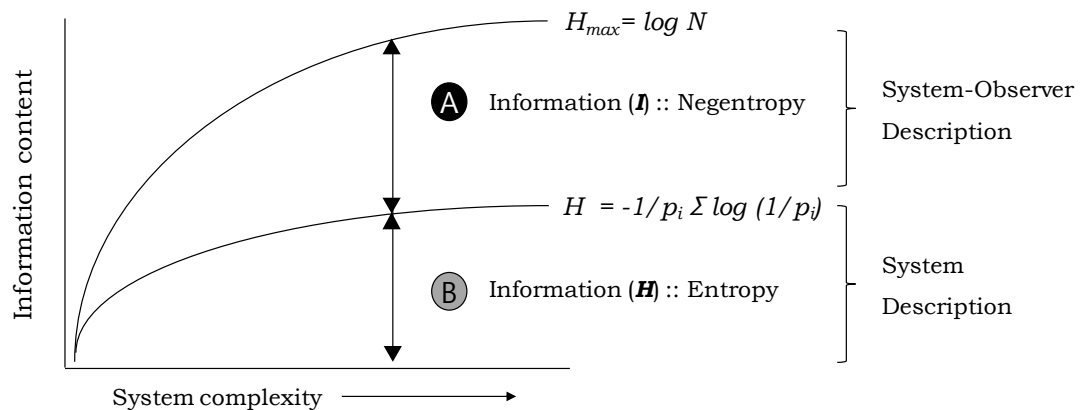

Fig. 2.11 Definition of information and two types of information content

(A) Degree of organization (order), (B) Degree of disorganization (uncertainty, disorder, unpredictability) (Given a system, if N number of microstates are equally probable, namely in the most uncertain situation, the probability of each state (p_i) becomes $1/N$. Then, the information entropy is maximized such that $H_{max} = -\sum_{i=1}^n \frac{1}{N} \log \frac{1}{N} = \log N$.)

2.3.2 Entropy, order, and disorder

The popular conception that “entropy is a measure of disorder” may be correct in special cases of physics or chemistry, but must not be generally accepted for all cases (Leff, 2012; Martyushev, 2013). It may be due to no single definition as to what is ordered and how much strongly it is ordered. Depending on the subject of interest, order can refer to spatial regularity, systematic arrangement of a structure, a specified orientation of the arrangement, or a high density of substances, frequency in occurrence of an event with time. Distinction between order and disorder may also depend on whether a system is opened or closed. Previous research provides two interesting examples to break commonality of order and disorder, particularly with respect to spatial order and order of self-organization.

First, if disorder means rupture, falling apart of spatial structure, all rusting process should accompany an increase of entropy. But Leff (2012) shows that oxidization of metal decreases entropy ($4\text{Fe} + 3\text{O}_2 \rightarrow 2\text{Fe}_3\text{O}_3$; $\Delta S = -0.5\text{kJ/K}$) while increasing the surrounding entropy to 5.7kJ/K .

Second, according to the common sense based on theory of evolution, organisms

such as plants and animals are a more ordered system, a result of the self-organizing mechanisms and low entropy than inanimate bodies. However, Martyushev (2013) shows that entropy of an animate body can be both higher and lower than inorganic substances ($S_{\text{wood}} = 2.8\text{kJ/K}$, $S_{\text{silica}} = 0.7\text{kJ/K}$, $S_{\text{air}} = 6.8\text{kJ/K}$).

In principle, as Clausius's formula (Eq. (2)) indicates, entropy is essentially related with the energetic status of a system. Most, yet not all, stable energy systems have ordered spatial structures and orientations to preserve stored energy against frictional forces, but those observed phenomena are merely byproducts of atomic reactions and exchanges of the energy quanta within a certain timeframe during a system lifecycle. More correctly, Leff (2012) defines entropy as a "distribution of energy over system's volume" and "spreading over accessible microstates" (Leff, 2012). He correspondingly argues that entropy is a measure of uncertainty of energy states. This is consistent with Boltzmann's idea and Odum's statement that defines disorder as spatial dispersal of "energy" (Odum, 1971).

However, if an observed system is not isolated (i.e. allowing heat exchange with the external environment), and regulated by an innate genetic mechanism, the uncertainty of an ordering process may or may not go through a local decrease at a certain moment depending on the mechanism. Therefore, a trend of entropy 'change', rather than entropy value itself, must be examined throughout the system development. It should be noted, at this moment, that entropy change does not depend on quantity of energy potential but does on the amount of heat transfer. Energy influx itself may not be conducive to maintenance of a low entropy level, for the arrangement of quanta can cause a chaotic state due to introduction of new quanta (similar to turbulence generation when two flows converge). i.e., in order to decrease entropy, energy quantum must be concentrated.

In a nutshell, we may continue to use entropy for environmental study not as a measure of disorder, only as a measure of '*energetic disorder*'. Meanwhile, if one seeks to identify the global disorder of a system, the whole ordering cycle must be explored with measurement of entropy change. Then, the object of the measurement should pertain to the *distribution of energy quantum positions*.

THERMODYNAMIC METABOLISM OF BUILDING SYSTEM AND NETWORK ANALYSIS

Glossary				
Symbol	Unit	Term	Definition 1	Definition 2
<i>Information per individual</i>				
<i>H</i>	<i>bits</i>	Shannon index	Degree of uncertainty in probabilistic distribution	<ul style="list-style-type: none"> • Diversity of resource flows per individual
<i>AMI</i>	<i>bits</i>	Average mutual information		<ul style="list-style-type: none"> • Portion of efficient resource transfer
<i>L</i>	<i>bits</i>	Redundancy	$L = H - AMI$	<ul style="list-style-type: none"> • Order of flow organization • Degree of freedom in the selection of flow pathways • System resilience
<i>F</i>		Fitness ^a	Logarithm of the ratio of <i>AMI</i> (<i>A</i>) to <i>H</i> (<i>C</i>)	Degree of adaptability
<i>Scaled information measures</i>				
<i>C</i>	<i>bits size</i>	Capacity ^a	$C = H \cdot T$ (system size)	
<i>A</i>	<i>bits size</i>	Ascendency ^a	$A = AMI \cdot T$ (system size)	
ϕ	<i>bits size</i>	Overhead ^a	$\phi = C - A$	
<i>R</i>	<i>bits size</i>	Robustness ^a	$R = F \cdot T$ (system size)	
<i>TI</i>	<i>bits sej</i>	Total information ^b	$TI = H \cdot Em$	<ul style="list-style-type: none"> • Surrogate of the input empower of an ecosystem

Note: Definition 1: Mathematical definition; Definition 2: Definitions for ecological network analysis and this dissertation. **a.** Ulanowicz, 1986 **b.** Tilley and Thompson, 2015

H is a key term to describing the complexity of network-flow configuration in an ecosystem, and in this study, also used as a proxy measure of the potential “power” of an emergy-flow network. An organized (in terms of effective resource delivery) part of ***H*** is represented by ***AMI***, a degree of association between flows. A disordered portion of ***H*** is ***L***. In this study, ***L*** is defined as system resilience, because it can characterize system’s self-organizing potential. ***H*** can approximate system power, but it cannot clearly identify emergy power (empower), since it does not account for emergy inputs. Therefore, ***TI*** is employed to measure empower based on information content. ***C***, ***A***, **ϕ** , and ***R*** incorporates information measures with overall flow quantity. Nevertheless, they may not be available to compare buildings with different types of quantities, and thus, are not adopted for this study.

This chapter addresses a system-level perspective and tools of environmental performance evaluation that are new to building sustainability. Ecosystems principles are hypothesized to work at the building system level for material selection and organization of a specific formal pattern. For the specification of buildings systematic behavior in the next chapter, a generic model of the transport of environmental

resources is presented at the system level with an application of the fundamental principles of the ecological development, before it is considered for the indication of sustainability. Section 3.1 introduces a system-networking concept of sustainability with thermodynamic accounts, in an effort to reveal a new dimension of building sustainability. Section 3.2 presents a schematic building network model and thermodynamic ecosystems principles that are applicable to the new definition of building sustainability. Section 3.3 introduces mathematical definitions of information-based ecosystem indices. Pilot experiments are conducted to identify applicability of ecosystems principles to building with establishment of a generic building system model. Findings from the tests provide a rationale for the use of information as a new building performance indicator.

3.1 “A world of two metabolism” and global sustainability

McDonough and Braungart (2002) recognize that our planet is sustained largely by two kinds of energy source cycles; namely, the cycle of (i) technical and (ii) biological nutrients. The technical nutrients are the inflows of matter and operational energy that support our *technosphere* — man-made technology-driven environment to which built environment belongs, and the biological nutrients feed natural environment. Each of which consists of own metabolic flows of physical substances, but the conclusion is that those two are not indifferent. The technical nutrients of our civilization are in fact entirely obtained from nature.

McDonough and Braungart assert that cradle-to-cradle (C2C) recycling of technical (abiotic) products helps promote ecologically efficient environment, and eventually enhances the state of global sustainability. As mentioned in Section 1.3.1, the C2C idea is congruent with Peacock’s mutual symbiosis concept, but more useful in a way that suggests a clearer configuration of the ecosystem design. C2C points out that the earth is a self-contained ecosystem through recycling of biological substances, but men’s poor understanding of the cycling has worsen the negative environmental pressure.

A general life cycle of an industrial product from the prevailing life-boat model can be schematized as in Fig. 3.1 (a) and (b). In this extensive energy transport process without recycling, environmental resources are simply thrown away as waste in the long run. To prevent the depletion, one may recycle, reclaim, or reuse the

resources in part or whole in the middle of the process, and then believe that the recycling is closer to sustainability.

However, C2C identifies the blind spot of this process. As a manufactured product is recycled, the quality of usability decreases, and accumulated emission of pollutant aggravates environmental health of our planet. As far as the recycling loop is opened, it is eventually depreciated, and, during the cycling, our environment becomes increasingly degraded (Fig. 3.1 (b)). McDonough names this vicious circle “downcycling”.

Therefore, to maximize the full advantage of recycling, the recycling loop must be closed with the tight connection of the biological and technical metabolism.³⁰ At a glance, the closing is not feasible, because any transport process of an industrial material always comes with an entropy increase, and, technically, a return to the same state is impossible. Nevertheless, notice that solar energy is plentiful enough to transform effluxes of hazardous disposal to useful natural sources. Ideally, at the end-of-life stages of the material, it can be disassembled into biological and technological nutrient. The biological constituent can be decomposed and become provision for plants and animals. Technical waste can supply high-quality raw materials of other industrial products. This metabolic coupling characterizes a virtuous cycle (*upcycling*) of an environmental system that leads to sustenance of high-quality, and the goal of sustainability is to maximize the nutrient flows³¹ (McDonough and Braungart, 2002).

This new paradigm of sustainability based on a positive symbiosis has been mentioned earlier by E.P. Odum, who said, “Mutualism seems to replace parasitism as ecosystems evolve towards maturity (Odum, 1983)”. So, that nutrient flows of the building are influxes of useful energy in terms of thermodynamics is in parallel with the ecologist’s recognition. Therefore, a tendency of increasing nutrients through a

³⁰ The definitions of the terms to describe the recycling processes vary from one author to another. The Global Development Research Center (GDRC), McDonough and Braungart (2002), and Yuan et al. (2011) use “closed”-loop recycling to refer to potential transformation of a particular mass of material into a different type of product, whereas the same characteristic of a system is termed “open”-loop recycling by US Environmental Protection Agency (EPA) and Lacarrière et al. (2015). This difference comes from the size of a potential production domain on which the material is recycled.

³¹ Bekker (1982) provides an illustration of upcycling in a nationwide system. According to his estimation, buildings in Netherlands dispose one million tons of wood annually to demolition. If two thirds of this waste were properly treated (collection, separation, and chipping), it could amount to be a source of all kilns of the whole brick and tile industry and also suffice to heat 125,000 dwellings. The different pattern of house conditioning and material production would create new jobs and increase household income, while saving around 300 million cubic meters per annum of natural gas.

closed-loop recycling could be consistent with the maximum power principle of autocatalytic ecosystem development which will be discussed in Section 3.3.

However, our built environment is neither perfectly open nor fully closed-loop. It is being settled in the middle of them. So, an integrated model of being mutually closed for biological and industrial cycle renders a clear description of how environmental building design actually develops (Fig. 3.1. (c)).

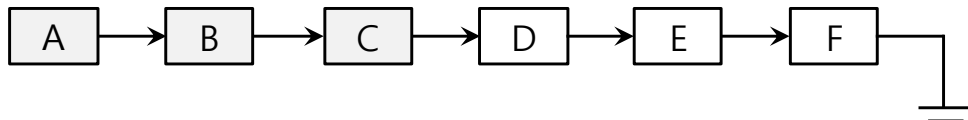

(a) Parasitism (life-boat model): no recycling

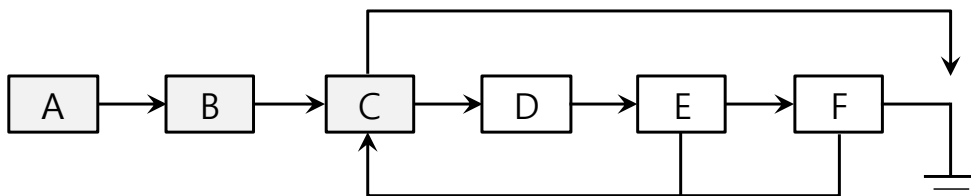

(b) Parasitism (life-boat model): open-loop recycling

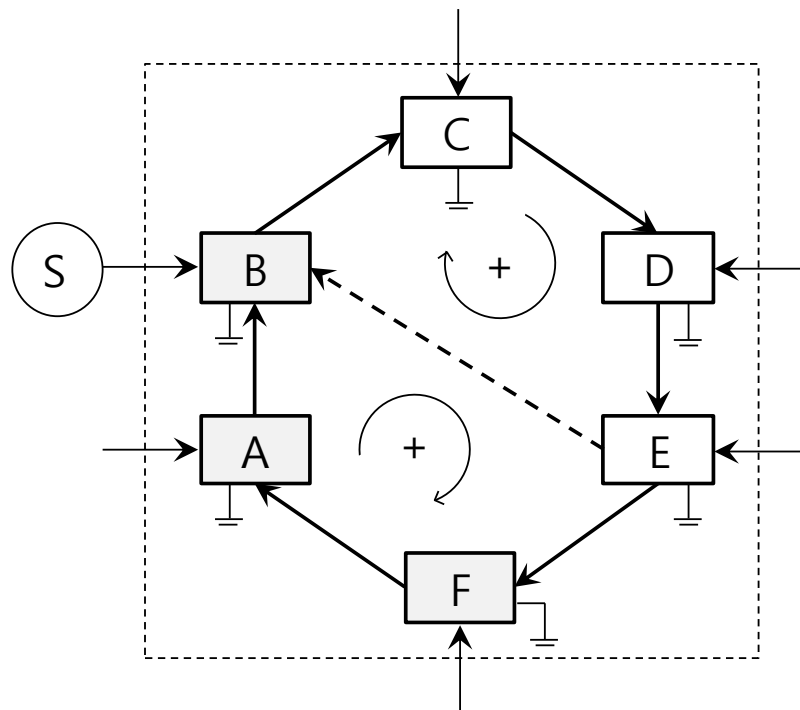

(c) Mutualism: closed-loop recycling

Fig. 3.1 Conceptual representation of sustainability models (A: material formation, B: social/industrial source, C: manufacturing/production, D: use/operation, E: waste disposal, F: decomposition and generation); B-C-D-E : technical metabolism, F-A-B : biological metabolism, S: source energy (solar, tidal, and geothermal heat)): Energy/material stock is easy to observe but changes at a slow pace. Flows are relatively harder to quantify but more effective to characterize system dynamics and sustainability due to its suddenness of variation and higher sensitivity to the environmental change.

3.2 Global thermodynamic principles of the analysis of an ecological system network

The second law of thermodynamics (law of entropy; SLT) is a universal principle applied to the entire processes of life and death, and predicts the termination of all living and non-living systems in the universe, thermodynamic equilibrium. If energy in a system is depleted and becomes wasteful (low quality energy; e.g., heat), the system will perish, and, conversely, if it gains useful energy (high-quality energy), it survives. However, it does not directly clarify the logic of ecosystems driving them to keep persisting against the death. In other words, even though SLT is ubiquitously true, it does not clarify why a highly-ordered system is naturally selected, survives in competition, and eventually well-fitted to the environment.

When SLT is applied to living organisms with respect to their sustenance, it presents a dilemma—what Jørgensen (1992) calls the *environmental paradox*. According to the SLT, any system has to maintain a lower entropy state during its life cycle to avoid thermodynamic equilibrium (heat death). However, every attempt to do so requires more energy inputs and information (negentropy), and, thereby, shapes a lengthy chain of energy exchange. In this process, SLT is indicative of more energy loss (waste of heat), and greater generation of entropy budget (Jørgensen, 1992). In other words, maintenance of the low entropy always brings on a higher entropy state.

This contradiction has been first noticed by Lotka (1922) in his study of ecosystems. He found that the “course of events in a physical system” did not strictly follow SLT, and mentioned “freedom of choice” in the course —system processing of energy transformation— is the main method of resisting to the equilibrium (Lotka, 1922). At the large system scale— the universe, there is no doubt about SLT, because the universe is assumed to be an isolated system. But, as Lotka (1922) suggested, systems continuously moving towards a non-equilibrium state are not subject to the

thermodynamic statement within the scope of the specific system level. The same holds for buildings. The following addresses a thermodynamic account of how building systems construct complexity in the account of thermodynamics. Measures based on similar but somewhat different hypothesis for system development must be integrated.

3.2.1 Order and disorder model and a metabolic understanding of building environmental functioning

The underlying process of all natural phenomena is the transition from order to disorder. They sound like casual words, but an energy-based perspective adds a thermodynamic rigor to both macro- and micro-scale observations. A system's energetic order requires (i) ability to maintain potential energy (low-entropy) and (ii) thermal concentration (spatial intensity that is differentiated from the dispersed entities of surroundings) (Odum and Odum, 1976).

A probabilistic definition can bridge the micro- and macro-scale processes, the order appears in a predictable state of molecular motions of a system, which is in fact a low-entropy state in terms of the Boltzmann's understanding, whereas disorder means a gain in uncertainty to describe a specific state of the system. That is, the justification for the use of information to identify order and disorder. The quantitative aspect of the system **order** can be referred to as the dual meaning of information which interchangeably connected: (i) amount of an observer's information (negentropy) about how much energy is associated at any instance with each mode of system quanta's energy possession (Dincer and Cengel, 2001), and (ii) low system's information entropy as a complexity measure indicating predictability (restraint of the "freedom of choice") of the quantum positions in the system's internal network.

A clear relationship between order and information is revealed throughout the order-and-disorder transformation. As SLT explains, orderliness of energy particles of a substance spontaneously turns into disorderliness with time (dissipation), and, vibration and motion of the particles in the way of the process generate useful energy as well as increase the freedom of choice and complexity of energy structure. So, more energy inputs enhance the complexity, which leads to higher information entropy.

In the growth and the evolution of biosystems and organisms, however, they generate a new order and maintain it from disorder through a hierarchical energy structure and metabolic functions. At the system level, the process of generating order pertains to a matter of “reproduction” by extracting or exchanging essential values of the available energy (useful energy) from low-entropy sources. A building is a highly-ordered system in terms of thermodynamics. It extracts energy from relatively disordered raw materials, and restructures them in a specific pattern. In an effort to reconcile physical laws and the process of life, such striking feature of the living systems, *order-from-disorder*, was proclaimed by Schrödinger (1944), as a central dogma of system organizations in both animate and non-animate processes. He said, “An organization is maintained by extracting order from environment (Schrödinger, 1944; Jørgensen et al, 2007)”, as an extended statement of SLT. What should be noted is that system complexity is directed to shape a hierarchy of energy flows. The inherent order of living systems is designed by a thermodynamic mechanism (Ulanowicz and Hannon, 1987). Through its life cycle, the construction of a building is to weave “energy” into a specified pattern. In this manner, all subsystems and component are affected by a higher level of order. In this understanding, a generic building system diagram based on the Odum’s order-and-disorder model provides a basis for identifying general dynamics of the energy transformation work (Fig. 3.2).

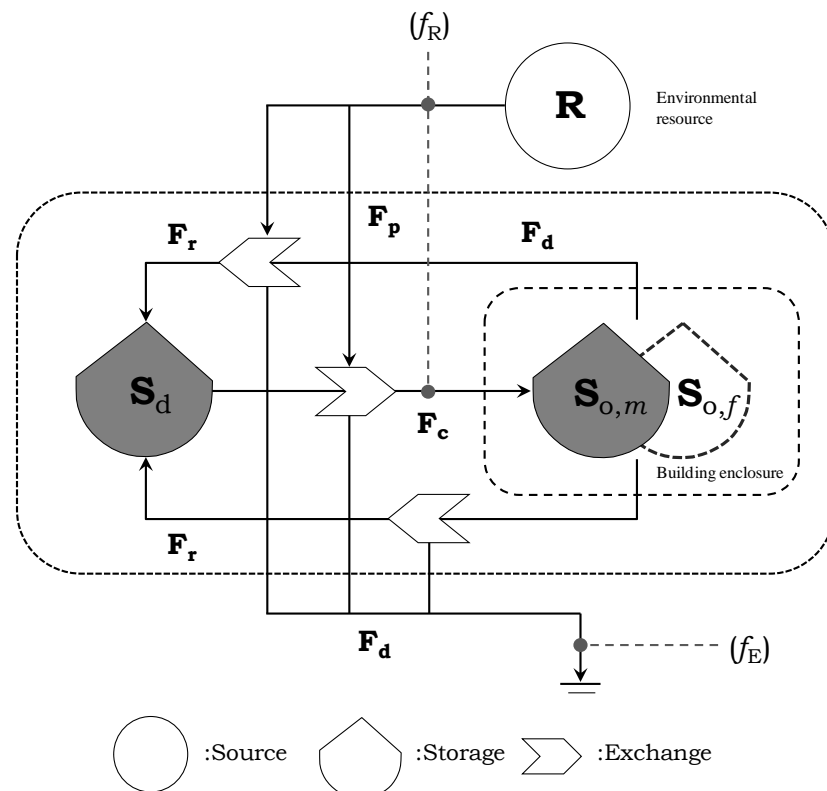

Fig. 3.2 Schematic system network model of building energy-matter metabolism:

This model is based on the Odum's order-disorder theory. (forcing functions: f_R, f_E) Each flow is denoted by R: potential energy resource, S_d : storage of disorder, S_o : storage of order ($S_{o,m}$: one of materials, $S_{o,f}$: one of building form). F_c is an "input" of the 'place-based building system, but, in terms of the whole building system, it is an "output" available for future use. *Production* (F_p): According to above definitions, all input sources of an ecosystem (e.g., fossil fuel, sunlight, raw materials, etc.) are in states of order and low-entropy (the solar energy is a huge low-entropy source due to the tight intensity of energy photon), and the ecosystem funnel the potential energy into their own mechanism. *Consumption* (F_c): occupant's activities for energy acquisition and utilization for human living. *Regeneration* (F_r): transition from order to disorder is natural, but living systems purposely feed backward flows for intensive upstream flow (F_c), by recycling material/energy, refurbishment, and employing human knowledge and/or intelligent devices. *Deconstruction* (F_d): emission, disposal, landfill.

3.2.2 Global principles of self-organization: Maximum entropy production (MaxEP) and maximum power principle (MPP)

Just as the spontaneous emergence of an orderly pattern during a living systems' developmental stages provoked a controversy over the SLT, it inspired many ecologists and physicists to explore more immediate theoretical foundations to explain the thermodynamic systems behavioral programs (such as homeostasis against perturbation) and the selective logic of system evolution. Most of the arguments for potential principles have been based on the survival of living systems. Without nourishment, no systems exist. Meanwhile, as Odum (1976) states "*everything is energy*," any form of nutritional substance on the earth is a form of energy. So, the acquisition of nutrients is the acquisition of useful energy, which is an essential prerequisite for the viability of all physical and biological systems. In effect, the energy acquisition needs extraction work. And, according to SLT, the work indispensably involves an entropy increase as it discounts the potential energy of a source. Hence, it is reasonable to postulate that production of entropy is a dominant indicator of all biological metabolisms.

Laws of entropy production

In mechanics, Prigogine established the theorem of minimum entropy production (MinEP) in 1945. The MinEP principle argues that a stationary or near equilibrium

system has a tendency to maintain the lowest entropy production rate (Prigogine, 1945)³². Prigogine's identification is notable because it presents a general mathematical derivation consistent with SLT, as it proves an orderly stable state must produce lower entropy. However, MinEP is a local theorem which is effective only with a strict linear condition and a state of very slow, purely diffusive transfer (Nicolis and Prigogine, 1977; Martyushev, 2013). It does not justify the transient increase of entropy of non-equilibrium, nonlinear systems which are far more general in animate systems. So, in a generalization of the narrow rationale, Jaynes (1957) and Ziegler (1963) recognized the concept of maximum entropy production (MaxEP), and Swenson (1988) articulated it as a cardinal thermodynamic principle. Later on, Schneider (1994) adopted it for the formulation of ecosystem models and functions. If an open system has a sufficient degree of freedom for system organization (e.g., molecular structure), it evolves towards a steady state with a more complex configuration that produces maximum entropy.

The MaxEP principle has two significant implications for system analysis. First, it breaks the common notion that entropy is an indicator of disorder. Proponents of the MaxEP principle have demonstrated that a system developing towards orderliness is an accelerator of entropy increase (Schneider and Kay, 1994; Toussaint and Schneider, 1998; Meysman and Bruers, 2010). Second, it is syntagmatically applicable to organizing behavior of biological and non-biological (physical) systems.

Most importantly, the theorems of entropy production (MaxEP, MinEP) feature in common they concern the “*rate*” of entropy increase. SLT introduces the notion of *time* to characterize the irreversibility of thermodynamic work as well, but does not explicitly employ it for energy discounting processes (Odum and Pinkerton, 1955; Ulanowicz and Hannon, 1987). The cornerstone of entropy production theorems is to incorporate the temporal scale (*a magnitude of duration* of the energy discounting) as a key indicator of the degree of system complexity (Ulanowicz and Hannon, 1987; Schneider and Kay, 1994).

System optimization principle: Maximum power and maximum empower

³² *If the stationary state of the process is stable, then the unreproducible fluctuations involve local transient decreases of entropy. The reproducible response of the system is then to increase the entropy back to its maximum by irreversible processes: the fluctuation cannot be reproduced with a significant level of probability. Fluctuations about stable stationary states are extremely small except near critical points (Kondepudi and Prigogine 1998, page 323)."*

Earlier than propagation of the entropy production principles in mechanics, an ecologist Lotka (1922) argued that living organisms tend to maximize the rate of resource utilization for their growth (succession in ecological terminology) and biological systems with higher temporal density of energy output (“output” here means available energy stored within the system’s body, it does not necessarily exit it.) are more likely to succeed in the struggle for existence. Inspired by the Lotka’s tentative theorem, Odum formulated maximum power principle (MPP) extending it to all types of ecosystems, arguing that “living and also man-made processes (including human civilizations) do not operate at the highest efficiencies that might be expected of them (Odum and Pinkerton, 1955)”.

The key concept of the MPP is that it associates the maximum power state with “optimal” efficiency, which is always less than maximum efficiency. Physical and biological systems sacrifice efficiency of energy transport for obtaining more quantity of useful energy and vice versa (reciprocity of power and efficiency) (Odum and Pinkerton, 1955) (see Appendix D). It is important to note that the effect of optimization does not necessarily appear over every component of the systems. Since the principle deals with system-level attributes, not individual compartment, the system efficiency is not maximized under a normal external condition, even if a single compartment attains 100% efficiency.

Odum refined the MPP to a principle incorporating the accumulated inputs of all upstream direct/indirect energy budgets, *emergy*, and finally proposed the maximum empower principle (MePP) (Odum, 1996). In a way, MePP is an extension of the MPP that sets temporal intake of “all available energy” as a cardinal index of biological development (Cai et al., 2004; Ulgiati et al., 2007; Li et al., 2013). Conflation of the energy quality and quantity helps elucidate the hierarchical transformation of energy, extending it to the most primitive inputs (sunlight, mineral, rainwater, etc.) (Hall, 2004). MaxEP, MPP, and MePP are compatible with one another (Appendix D.1) in that they deal in common with the change of total “free” energy inside the system. An entropy increase involves exergy change (Eq. (2.4)), and MPP is a quantitative postulate of the trade-off between the entropy change rate and system efficiency.

Importantly, those principles expound the final cause of development— a system’s spontaneous resistance to modification of the external environment and acquisition of

more useful energy. At a glance, the notion of maximum power sounds scientifically controversial, because conservation of diminishing sources is a demanding pressure. The struggle for the least stressful condition and maximized harnessing of available energy can be seen as a greedy act. However, such narcissistic behavior of a single organism is not self-centered but a self-reinforcement to benefit a whole ecosystem through feedback, since sustenance of geobiosphere is profitable for the organism itself in the long run. Therefore, the maximum power production is the ultimate goal of sustainability of all physical, non-physical systems in the earth. As Odum speculated (Odum and Pinkerton, 1955), sustainability of our civilization and building environment must be subject to attainment of maximum power, not the blind commitment to reaching maximum efficiency. Odum proposed the MePP as a comprehensive indicator of system development as it has been used to illustrate various types of system mechanisms, and, following Lotka's suggestion, he even proclaimed MePP as the fourth principle of thermodynamics. However, despite its paradigm-shifting support to the mutualism-based sustainability, there are several criticisms: (i) it does not predict any threshold of power at the maximum stage, (ii) although the principle has been noticed by observational investigations, the laboratorial monitoring still lacks sufficient number of empirical demonstration, and (iii) it is not unconditionally true. Since it premises a dynamic state with plentiful food supply to ensure full degree of material choice of the system organization, a system under insufficient supply of the resources could pursue maximum efficiency rather than intermediate efficiency. Although, applicability of MePP for buildings will be explained in this study, many researchers have challenged the first and second concern through case studies (Cai et al., 2006; Li et al, 2013), and noticed the increase of useful energy influx through complex changes of community structure and chemical constituents. Previous studies found the maximum value of system power depends on the attributes of energy pathways, and external forces.

The third criticism is especially noteworthy. If an abundance of resources is not the case of a system, maximum power may not be effective. A cactus enhances its overall power for effective absorption of water, limit of choice of material on a barren land may bias against MePP. And in a barren regions, ecosystems grow quickly to use up immediate resources.

Our focus on global sustainability must be based on the MePP. When it comes to building sustainability, which has to deal with global development of human society,

this is a local deviation, or temporarily appears due to the recognition of resource shortage. For example, as shown in the recent explosive production of shale gas in US, if we innovate conventional ways of energy exploitation, operative resources for our society are not insufficient as far as solar energy is transmitted to the earth.

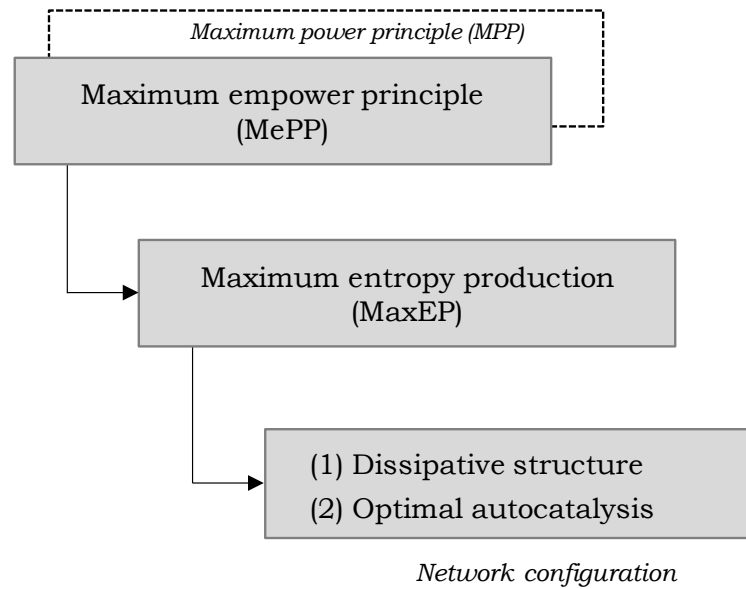

Fig. 3.3 Compatibility of global ecosystem development principles: Increased available energy intake towards development does not only affect quantity of the energy flow but also leads to notable characteristic of system properties and configuration of pathways through self-organization such as: (i) higher diversity, (ii) development of feedback loop (iii) pulsing between producers and consumers, (iv) relatively higher efficiency after growth (a state of minimum entropy production) (v) hierarchical structure of energy transaction based on the energy quality (Jørgensen, 1992; Toussaint and Schneider, 1998; Cai et al., 2004). For network analysis, the most critical aspects of self-organizing complexity are (i) *autocatalytic* organization through increased cycling activities and (ii) generation of diverse pathways for maximizing total *dissipation*. Diversity of system components, pulsing, and the appearance of hierarchical trophic levels are results of the construction of complex structure.

3.2.2.1. Development of dissipative structure

In the process of utilization of environmental sources, an open, far-from equilibrium system tends to dump wasted energy as a form of heat (Prigogine, 1980). If the system produces more energy, it needs to be able to degrade the energy more quickly with an expanded structure. That is, the goal of dissipative structure is to

abet entropy production. Effective complex and elaborated network structure of exergy drainage must emerge in system growth and development, which lead to maximum power.

3.2.2.2. Autocatalytic network and maximum complexity

The complexity of self-organization often depends on “indirect” connectednesses between compartments (a causality of input-output is found between nonadjacent nodes). However, such indirectness is not unconditionally conducive to sustainability, because disoriented complexity can bring on a biased development that makes fragile an ecosystem in the end (Ulanowicz, 1997). In that sense, the mutual sustainability needs the system to develop *autocatalytic* network (Ulanowicz, 1997). Autocatalysis means that an outcome of energetic reactions becomes a catalyst for first reactants (inputs).

Like dissipation (exergy destruction), autocatalysis is compatible with MePP in that storage of the power is maximized only when system components of different scales are collectively, interdependently connected on a balanced circulation of input-output of the sources (matter, energy, and information). Autocatalysis is also an identification of the system’s ability to recycle; i.e., use wasted energy and matter to feed itself back so that they amplify generation of the sources, which is a fundamental activity of enhancing network quality towards mutual symbiosis. Hence, a maximum power state at which none of absorbed energy leaks attains full autocatalytic connection— energy is stored, conserved, and managed to be circulated throughout the whole ecosystem.

The increased amount of internal material flows caused by autocatalysis corresponds to longer cycling lengths and a decrease of turnover time of the cycling (Schneider and Jay, 1994). The greater number of the circulation the more complex system organization, which leads to an increased amount of power. Ecosystems develop control functions of power progressively through the cyclical pathways (Patten, 1992; Odum, 1996). In this sense, the indirect effects of the autocatalytic network have been called “*amplification*”, “*synergism*” (Fath and Pattern, 1999), or environmental “*order*” due to its ability to maintain the potential energy (Ulanowicz, 1997). Hence, by applying the degree of autocatalysis as the fundamental criterion to evaluate the system states, we can assess power intensity and the degree of

sustainability (Fig. 3.4).

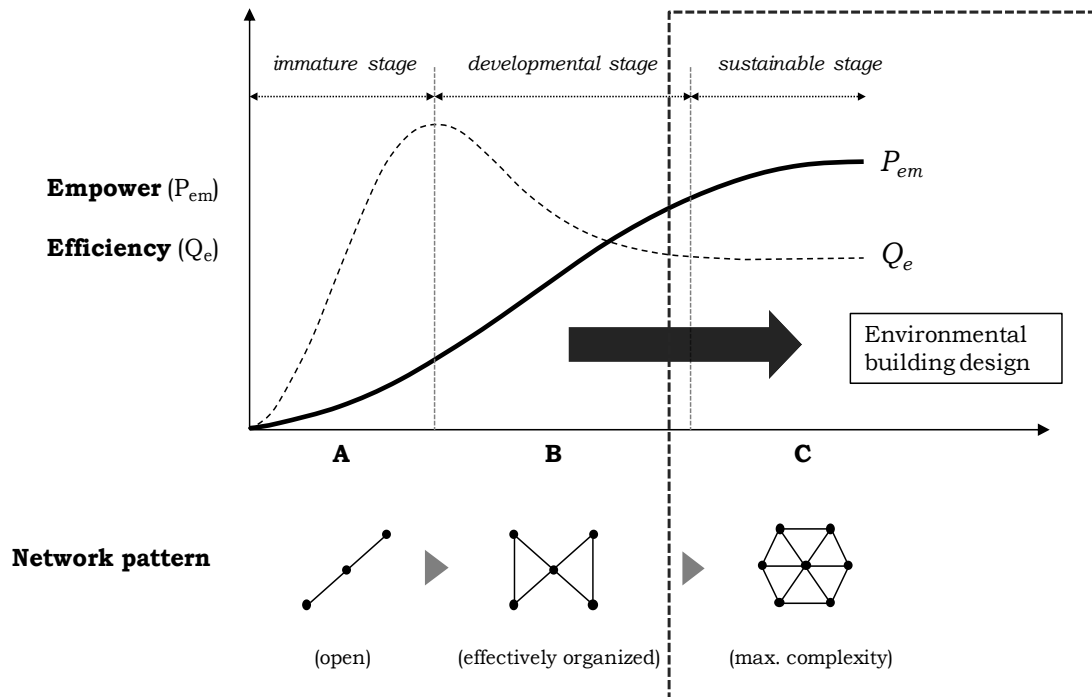

Fig. 3.4 MePP, self-organization, and degree of global system development (under steady-state condition): MaxEP, MPP, and MePP are essentially extended statements of SLT, and the specific structural organization of resource flows (dissipation and autocatalysis) is a network-version surrogate of the principles.

3.3 Power and Resilience: System-level indices of sustainability

As discussed in Section 3.2, indication of building sustainability is associated with combination of extensive and intensive changes (Eq. (3.3)). Non-equilibrium systems undergo fluctuations of extensive input quantity; e.g., the variable rate of throughput of energy, matter, and information. Such fluctuations belong to a function of external constraint (f) and complexity of internal organization, which are subject to temporal intensity of the external variations. However, further elaboration is required to clarify the formula with the following questions: how do local ecosystems control the balance of external and internal functions? Which contributes more to the systems to maintain developmental activities over time?

In 1886, Boltzmann asserted, even though he found little immediate evidence, that living system's general struggle for their survival was not for acquisition of raw

materials (because the global ecosystem was not yet at the equilibrium, and relatively plentiful are air, soil, or water) and energy, but for “entropy”—utilization of the energy and matter (Boltzmann, 1886; Schneider and Kay, 1994b). This argument means the quantity of external resources function (f) is not the most limiting factor of ecosystem development (Jørgensen, 1992), but the system’s “response” to the external stress and managerial ability is critical. Therefore, we have to notice that the function (g) of intensive parameters is the key to achieve building sustainability, because it connotes the time and context of our civilization in which the boundary conditions of the building system is situated, and explains the supportive backgrounds of the social and cultural forces (e.g., climate, technology, and social content). In the scarcity of the external sources or external perturbations, the organizational state controls how to gain access to the environmental sources, and acts as a brake that manages inflows when the external quantity enters the building system. Eventually, the strength of the internal composition becomes the power to resist the unfavorable conditions.

From this perspective, the organizational aspect of system network properties for survival should be the imperative of sustainability evaluation. So, the evaluation of the mutualism-based building sustainability is refined to the level of exploring the characteristics of the network itself, such as total throughput, degree of cycling, turnover rate, and direction of interactions that are widely used in ecosystem analysis to identify the system’s capacity to retain function, structure, and feedback. To identify such properties, systems ecology sets the tone for the research of “*stability*.” Ecosystem stability is a highly complex definition (May, 1973), and its evaluation is not possible without a rigorous consideration of the methods of quantitative measurement as well as study of reaction mechanisms. Many researchers have proposed multiple biological concepts and definitions to describe associative system properties such as *adaptability*, *buffer capacity*, *resistance*, or *elasticity* (Jørgensen et al., 2007). However, direct use of those constructs may be too general for a cursory analysis, or too speculative to understand the complexity of the systems energy exchange based on the networking of entities.

Nevertheless, among those measures, resilience is of particular importance, because it refers to the system’s ability to self-organize (Meadow, 2008). The ecosystem’s ability to evolve and sustain itself is in parallel with that of adaptation by restructuring a resource flow circuit. Resilience is, in effect, a multi-disciplinary concept widely adopted in different domains, from economics through social science

and computer engineering, to characterize a system's capacity for flexible self-recovery against untoward external conditions and unexpectedly varying circumstances (Smith and Stirling, 2008; Stokols et al., 2013). Resilience as an environmental measure was first discussed in the ecological arena by Holling (1973). He defined resilience as the “persistence of ecosystems and their ability to absorb change and disturbance and maintain the same relationship between state variables (Holling, 1973).” Resilience does not only highlight the homeostatic aspect but also the evolutionary capability such that a circuit of energy within the system forms a dynamic closure (Ho and Ulanowicz, 2005). Depending on situation, a structure of closed connection can be opened to yield energy flows to those that require energy for the system growth.

Based on these statements, this study finds resilience as a definitive index of systematic ecosystem sustainability, in addition to the system power. While the power is primarily concerned with resource availability and the development of the hierarchy of forward transmission, resilience, and stability, underline the network balance between self-prosperity (*robustness*) and flexibility (*adaptation*) through the development of feedback loops in presence of perturbation. E.P. Odum argues that mutualism evolves to produce resilient systems (Odum, 1983). Fath et al. (2003) define, “ecosystem resilience is a measure of the ability of an ecosystem to maintain function in the presence of disturbance and change³³” In this sense, we conclude that resilience is the most appropriate term to characterize mutual networking of a building system, because it is the most inclusive ecological concept of describing the stability of the organization, which can also be extended to refer to “resistance” and “*buffer capacity* (Jørgensen, 1992)” (Jørgensen et al., 2007). It is similar to elasticity (Orians, 1975) but more inclusive (Jørgensen, 1992).

3.3.1 Locality of building sustainability and information

Sustainability based on mutual metabolism complies with the principles of biological and non-equilibrium thermodynamic system development, such as maximum (em)power and maximum entropy production, because the mutual

³³ However, Jørgensen (1992) is reluctant to use the concept resilience as a quantitative term, because a system theoretically resilient, but technically never return to an original state before perturbation.

connection of ecosystem functions is the best way of augmenting useful energy inflows and dissipation by autocatalytic feedback. Autocatalysis is an efficient way of self-proliferation and multiplication of a biological entity, because the synergetic cooperation between components continuously spread over the whole system with the least number of pathways. R.E. Ulanowicz argues that autocatalysis accelerates a system's centripetal tendency to bring more energy and information into the system circuit (Ulanowicz, 1997). In this mechanism, the conventional relation of source, producer, storage, and consumer is incessantly reconstructed with the variation of compartmental connectivity and storage power (Fig. 3.1. (c)). Even though the law of maximum (em)power is valid at every scale (Odum and Pinkerton, 1955) and fine-tunes ecosystems like the "invisible hand" (Li et al., 2013), examination of mutualism using short-term energy fluxes may lead to a biased interpretation and not provide a practical sustainability assessment of *local* ecosystems (such as building and built environment). This concern is largely due to the following reasons: (1) theoretically, energy power can be estimated by identifying initial inlets of energies or the total amount of energy degraded, yet the measurement involves a great deal of uncertainty, particularly for complex systems *dynamically* moving away from thermodynamic equilibrium, (2) the behavior of local systems can be quite different from that of the global system. Scarcity of local sources may cause the development strategy of the local system to prefer conservative activities by reducing entropy production, and, hence, the maximum power law may not apply at this case, since the principle presumes abundance of useful resources. (3) Due to the limit of the system analysis window, it is very hard to estimate the contribution of local systems activities to global evolution towards maximum power. Even if that is possible, the generality would diminish the resolution of the result, and (4) As Jørgensen (1992) argues, ecosystems never return to the same state. Even though behavior of a local state is clearly analyzed and predicted, the general local system order does not deterministically match with the attributes of the global complexity due to the randomness of the organizing pattern of the geobiosphere functions. Thus, mutualism based on autocatalytic mechanisms and the degree of useful power must be a global model of sustainability, but, they may not be appropriate to be a direct indicator of local system states. As for built environment, like any other local living systems, stable cycling of subsystem populations and a durable supply of biological/technological sources around a local area has a powerful impact on the

sustainability. Therefore, we have to focus more on the system's instant *potential* that draws its spontaneous move contributing to a continuous global increase of the system power in accordance with other local systems as well as the global system. In this sense, a degree of resilience can be seen as an inclusive measure to reflect the qualitative/quantitative aspects of the system's self-sustenance, controllability, and protection.

For building design, a hidden side of the attempt to characterize every facet of self-organization (e.g. hierarchy and degree of energy accumulation) in a fixed position can be seen as an extension of the mechanical idea, because the hierarchy between system elements and the intensity of energy exchange are not explicit, but ever-changing. In this light, the resilience-based view of sustainability embodies a profound transition in the examination of sustainability in two regards: (1) it requires us to shift our attention from a deterministic judgment about building performance of a static state into a *probabilistic* description of the building's dynamic behavioral *tendency* heading to evolutionary design, (2) The quantity of energy and mass is still influential, but the main target of performance evaluation should be their flowing direction and distribution throughout the building ecosystem's metabolic network. Now, we have to answer some questions that may arise at this point, such as: what makes the flux of energy and mass change? And what do we have to measure to monitor the degree of resilience? As shown in the Schneider and Kay (1994a)'s Bénard cell experiment (Section 3.2), variations of external conditions eventually affect the entropy production rate (system behavior). This clearly demonstrates that "something" stored in the system becomes a dominant player in rearrangement of the internal motions of energy and mass; that is, *information*. As Odum (2007) illustrates, living systems try to utilize more energy to maintain non-equilibrium state at an optimal operating point(s), but it is only accomplished by "continuous application of information (Gatenby and Frieden, 2007)." Information is transmitted through and stored in a *network configuration* of an ecosystem, and it maps the energy and mass over the organization by controlling the activation of useful nodes and links during the developmental stages and crisis (Janssen et al., 2006), thereby changing (1) the level of connectivity between system components, (2) network centrality, and (3) the strength of power storage. So, that information is the most critical factor to indicate the system's resilience, and it is a macroscopic system-level property. This finding also lets us define a building as a channel of information (e.g., adding a new material

to the building envelope would change the internal heat distribution due to the information encoded in the material), and informs that the environmental performance of the building can be monitored by information change.

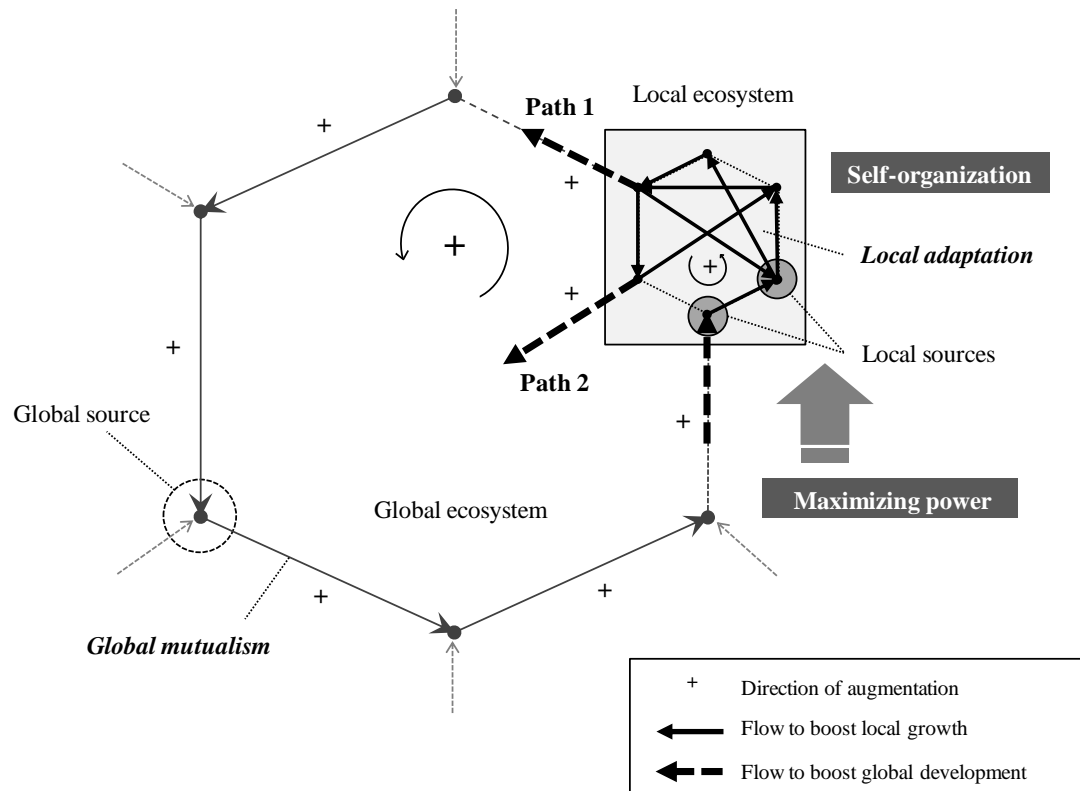

Fig. 3.5 Concept of system resilience and duality of systems sustainability: Path 1 and 2 indirectly amplify the local sources for the local ecosystem to obtain more potential energy by augmenting remote global sources. Internal autocatalytic network directly strengthens the local sources. Resilience refers to assurance of the local system’s spontaneous interplay of the indirect and direct effect, thereby ability of existence under unpredictable global conditions.

Nevertheless, the task of quantifying resilience with information is challenging. First, even though information is recognized as a physical quantity, it can be noticed only by a variance of its carrier’s state variables and relationship with other substances. The following section discusses the quantification methods of resilience. Second, a large stack of information leads to a highly-developed system (Odum, 1981), but the simple complexity due to incoming information does not guarantee a “resilient” hierarchy of the system components. As discussed in Chapter 2, information of the energy network is measured with stochastic distribution of

quantum, which are generally assumed to have no interaction to one another, but they are not in fact completely independent (Wiener, 1948). Koestler (1967) mentioned “self-assertiveness” of energy particles of biological systems (called “*holons*”) (Allen and Starr, 1982). This means that energy fluxes of ecosystems are not arbitrary, but the particles of the flows integrate particular functions of a larger whole. Koestler asserts that the development of a hierarchical organization based on the energy particles’ dual tendency is the inherent hallmark of all living systems (Koestler, 1967). That is, we have to understand that resilience is an emergent property from self-cohesiveness. It is consistent with embedded information that is subject to external perturbations. The “independence” and “dependence” of the system organization must be considered simultaneously in the evaluation of resilience (Fig. 3.5).

3.3.2 Evaluation of information content: Quantification of power, organization, and complexity

A few quantitative evaluation methods of the flow topology of an ecosystem network have been proposed. They stem from a similar intuitive understanding—a cycling of a medium on pathways, but each measure has a different mathematical background. Bernard Patten (1985) analyzed a distribution of total throughput over the structured pathways of the ecosystem with a Leontief’s matrix function for economical input-output analysis. Although this study does not explore his theory, Ulanowicz’s ecosystem analysis shares its fundamental understanding, partly derived from the Patten’s, and it focuses more on the uncertainty of a single quantum by reinterpreting Shannon’s information theorems in average mutual information (Ulanowicz, 1986).

3.3.2.1 Evaluation of reciprocal connectivity (developmental organization): Average Mutual Information

The definition and mathematical formulation of average mutual information (AMI) were introduced by Gallager (1968) within the communication theory discipline. Rutledge et al. (1976) applied it to systems ecology to characterize the stochastic nature of ecosystem succession. Based on the hypothesis that the ecosystem organizations mature towards autocatalytic networks for succession (Ulanowicz,

1980), Hirata and Ulanowicz (1984) proposed an AMI-based index in order to assess the developmental pattern of an ecosystem structure.

Then, why and how is AMI chosen as a system maturity index? Because the concept and the target of measurement are consistent with the major ecosystem principles such as (i) the maximum power principle (Lotka, 1922; Odum, 1963) and (ii) the exergy-storage hypothesis outlined by Jørgensen (1992), which both state system evolution increases system throughput by developing various routes of energetic sources particularly including “feedback” loops. Intuitively, we are aware that the more inter-compartmental flows are diffused, the complexity of the total organization increases. Uncertainty of the flow distribution accordingly will rise. However, in terms of where a flow originates, uncertainty (capacity of information) may or may not be increased depending on the diffusivity of the network configuration.

Suppose that a simple binary network is composed of two elements namely i and j (Fig. 3.6). The inflow to j (f_1) from i yields a constraint of the flow capacity. However, as j develops a positive feedback path (f_2), the flow out of j may influence f_1 conversely. That is, jointly, both i and j are a “source” and a “reservoir” at the same time. One may need to assess such an interactive effect. As for a system network, information is the stochastic index of the network structure that is indeterminate but apparently away from an arbitrary configuration. Therefore, mutual information evaluates the “reciprocal restrictions of the compartments” that make the network organized in a certain manner. “Mutual” here refers to “an indirect relationship” between a pair of compartments due to feedback paths or unclear source of the inflow for each element. Therefore, the mutual information is a suitable measure to identify a constraint from an implicit interaction occurred in the self-organizing ecosystem progression.

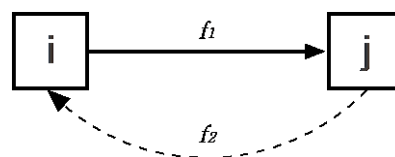

Fig. 3.6 Representation of the AMI concept

For mathematical discussion, the mutual information can be defined as the measurement of residual uncertainty due to “unknown (unobserved)” events given probabilistic events of flow distributions (Latham II and Scully, 2002). Then, AMI is a weighted sum of the uncertainty for each unit flow. This reminds of Bayes Theorem that deals with *posteriori* and *priori* distribution.

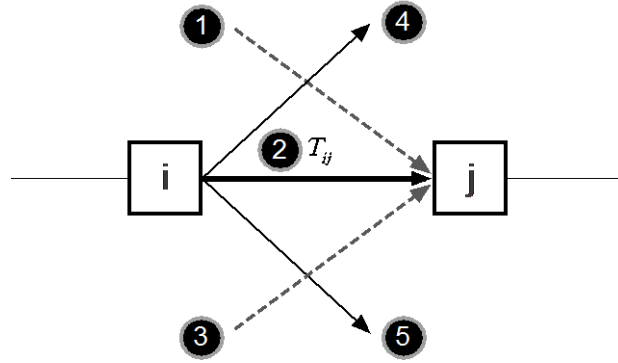

Fig. 3.7 Formulation of AMI: (1) external import to j , (2) internal transfer from i to j (T_{ij}), (3) internal transfer to j , (4) flows out of i to other compartments, (5) export and dissipation.

AMI is represented with the logarithm of the probabilistic ratio of a posteriori to a priori event (Appendix A) which means subdivision of uncertainty in a known source (a priori) from total uncertainty (a posteriori). Extended from Fig. 3.6, Fig. 3.7 displays all possible flows between the pair. Let uncertainty of this unit pair be U_{ij} , by the Shanon information, U_{ij} is obtained by,

$$\begin{aligned}
 U_{ij} &= -k \log \frac{T_j}{T} - \left(-k \log \frac{T_{ij}}{T_i} \right) \\
 &= k \log \frac{T_{ij}T}{T_i T_j}
 \end{aligned} \tag{3.7}$$

where T is total system throughput, T_i is the total flows leaving from i ((2)+(4)+(5)), T_j is total inflow to j ((1)+(2)+(3)), and T_{ij} is transfer from i to j . Setting the the coefficient k of the scalar constant equal to 1, the weighted sum of unit uncertainty becomes AMI

as follows,

$$\begin{aligned}
 \text{AMI} &= \sum_{i=1}^m \sum_{j=1}^n U_{ij} \\
 &= \sum_{i=1}^m \sum_{j=1}^n \frac{T_{ij}}{T} \log \frac{T_{ij}T}{T_i T_j}
 \end{aligned} \tag{3.8}$$

where m is total number of outflow paths of i , and n is total number of inflow paths of j .

Fig. 3.8, 3.9, and 3.10 show AMIs calculated for three sample networks. Fig. 3.8 demonstrates that AMI is a measure of system organization. In Fig. 3.8 (a), T_i equals to T , and T_{ij} also equals to T_j , thus AMI becomes zero which means no flow from unknown sources (all flows to B, C, and D come from A). In the perfect autocatalytic loop (Fig. 3.8 (c)), AMI reaches the maximum.

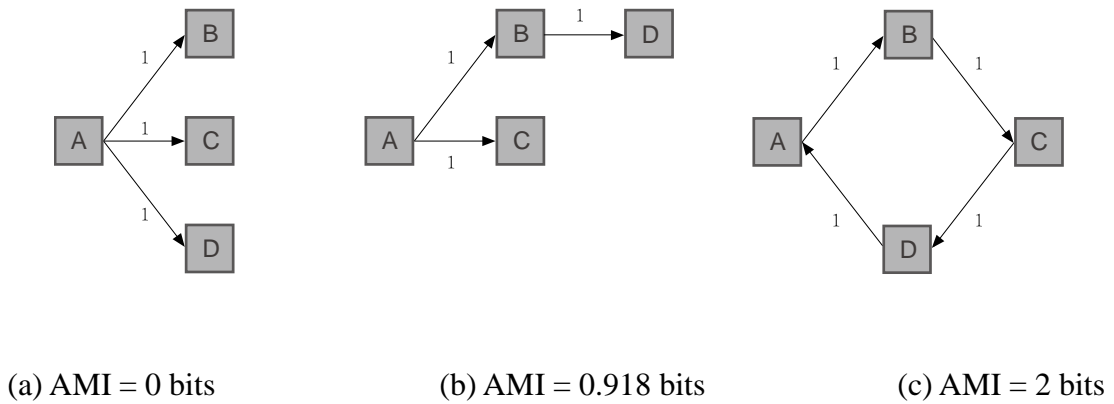

Fig. 3.8 AMI is the measure of a network

Fig. 3.9 demonstrates AMI is not only the measure of the profile of network construction. A target of AMI measurement is the unit of flows, i.e., a quantum of the flows, because average mutual uncertainty is dependent on the relative flow quantity to which a quantum belongs to. That is, AMI is the “quantum-based” description of a network configuration.

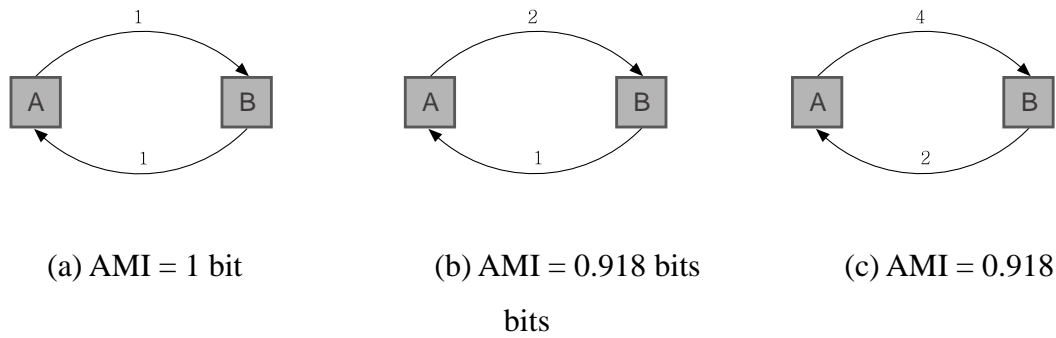

Fig. 3.9 AMI is the quantum-based measure, a probabilistic distribution of quantum

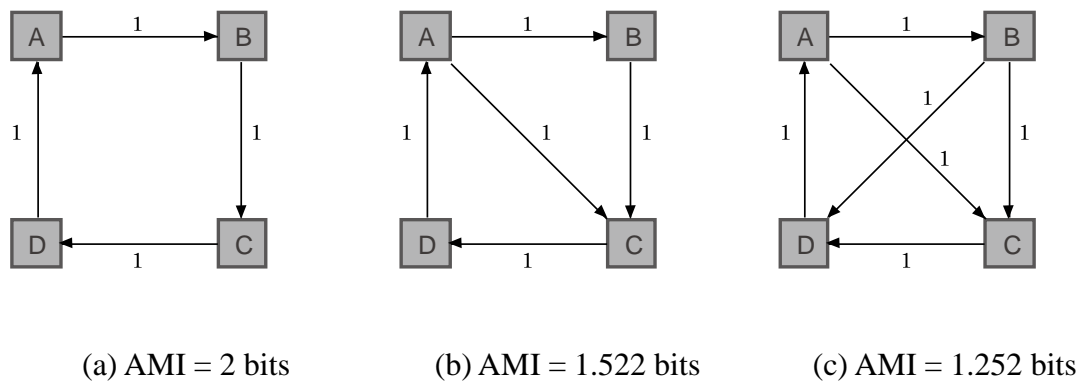

Fig. 3.10 AMI is not the measure of the intricacy of a configuration. Pruning of redundant paths increases AMI.

As depicted in Fig. 3.10, AMI is maximized when a quantity of medium is evenly distributed on each path branching into a perfectly cyclic direction. However, the maximum level of AMI, which becomes the same as the total information of the system network, can never be achieved for local ecosystems because the ecosystems always encompass open ends such as sources and sinks.

AMI is, therefore, compromised by being reduced into a certain level. Work of adjustment is the work of self-organization. The balance and the level of complication at which AMI is compromised are the targets we have to evaluate for a sustainability index.

3.3.2.2 Probabilistic indicators of local system behavior

(A) Asendency and Overhead

Resilient ecosystems basically seek to run under an optimal system operation with an alignment of network balance between metaphysical efficiency of internal development and system redundancy against extraneous perturbations (Ulanowicz, 1997).

In an operational process, efficiency is maximized if and only if the ecosystem medium (energy or mass) is circulated through each participating component via an autocatalytic loop. The information of autocatalysis results in an effective self-enhancing mutualism that prunes pathways of untoward (less efficient) directions. In this regard, AMI is a perfect indicator of such patterning, because it is also maximized if the quantities are evenly distributed over pathways of a circulating alignment. From this finding, Ulanowicz defines “*ascendency (A)*” as a measure of system development using AMI (Eq. (3.8)) multiplied by total system throughput (T) such that:

$$\begin{aligned}
 A = T \cdot \text{AMI} &= T \sum_{i=0}^{m+2} \sum_{j=0}^{n+2} \frac{T_{ij}}{T} \log \frac{T_{ij}T}{T_i T_j} \\
 &= \sum_{i=0}^{m+2} \sum_{j=0}^{n+2} T_{ij} \log \frac{T_{ij}T}{T_i T_j} \quad (3.9)
 \end{aligned}$$

(0: external input (import), $m+1$ and $n+1$: system output to external environment (export), $m+2$ and $n+2$: depreciation)

Ascendency becomes an indicator of “structure-enhancing configurations (Ulanowicz, 2009)”, and the capability of system repair for self-development. However, full autocatalysis is a result of mechanical construction and highly improbable in reality, because it easily fails (brittle) in the case of unpredictable events (noise), which occurs quite frequently in the real world in which local systems are immersed. Accordingly, to maintain system integrity (order), local ecosystems prepare for the emergencies by embracing internal disorder, which Ulanowicz (1980) calls “*overhead (ϕ)*.” The concept of overhead is critical to the quantitative definition of resilience in that it stands for the system’s flexibility and potential of future evolution (Ulanowicz et al., 2009). Overhead is calculated by subtracting ascendency from total system *capacity (C)*. The capacity is calculated by multiplying system throughput (T) and overall uncertainty of particle distribution (Shanon information,

Eq. (2.7)). During the system's development, it is hypothesized that capacity gradually increases. Capacity is given by:

$$\begin{aligned}
C = T \cdot H &= -T \sum_{i=0}^{m+2} \sum_{j=0}^{n+2} \frac{T_{ij}}{T} \log \frac{T_{ij}}{T} \\
&= - \sum_{i=0}^{m+2} \sum_{j=0}^{n+2} T_{ij} \log \frac{T_{ij}}{T} \quad (3.10)
\end{aligned}$$

And, then, overhead is computed as:

$$\begin{aligned}
\phi = C - A &= - \sum_{i=0}^{m+2} \sum_{j=0}^{n+2} T_{ij} \log \frac{T_{ij}}{T} - \sum_{i=0}^{m+2} \sum_{j=0}^{n+2} T_{ij} \log \frac{T_{ij}T}{T_i T_j} \\
&= - \sum_{i=0}^{m+2} \sum_{j=0}^{n+2} T_{ij} \log \frac{T_{ij}^2}{T_i T_j} \quad (3.11)
\end{aligned}$$

where $C \geq \phi \geq 0$ and $C \geq A \geq 0$.

System resilience (L) is defined,

$$L = \frac{\phi}{T} = H - AMI \quad (3.12)$$

(B) Fitness of system evolution and consistency of resilience indicators with maximum power principle

The resilience indicators (A , ϕ , and C), were integrated by Ulanowicz (1997) to suggest new indices of ecosystem resilience, namely, “*fitness (F)*” and “*robustness (R)*.” Fitness is the ratio of ascendancy and capacity multiplied by the logarithm of the ratio, and robustness is a sum of the fitness for each particle such that:

$$F = -\frac{A}{C} \log \frac{A}{C} = \frac{\sum_{i=0}^{m+2} \sum_{j=0}^{n+2} T_{ij} \log \frac{T_{ij} T}{T_i T_j}}{\sum_{i=0}^{m+2} \sum_{j=0}^{n+2} T_{ij} \log \frac{T_{ij}}{T}} \log \frac{\sum_{i=0}^{m+2} \sum_{j=0}^{n+2} T_{ij} \log \frac{T_{ij} T}{T_i T_j}}{\sum_{i=0}^{m+2} \sum_{j=0}^{n+2} T_{ij} \log \frac{T_{ij}}{T}} \quad (3.13)$$

$$R = T \cdot F \quad (3.14)$$

This formulation seems straightforward, though; metaphysical interpretation implies that F is the average uncertainty of an energy quantum towards ecosystem's order— i.e., a normalized factor of effective accumulation of useful energy and the local system's potential to self-organize for evolution. Robustness (R) is an adjusted value of fitness augmented by the magnitude of total network flow. Both have essentially the same nature, representing a system's adaptability to changes in the external world, and an observer may choose one of them as a design criterion. Robustness is suitable for evaluation of different kinds of systems because it reveals the scale of the system being assessed. However, if one seeks to identify inherent resilient attributes of system activities or fraction of resiliently active fluxes in throughput, fitness would make greater sense, since it measures “developmental” adaptability by normalizing the degree of sustainability regardless of the system size and the amount of throughput (attributes of the system growth). A system with a fixed value of fitness may improve overall resilience by absorbing energy flows, thereby increasing robustness.

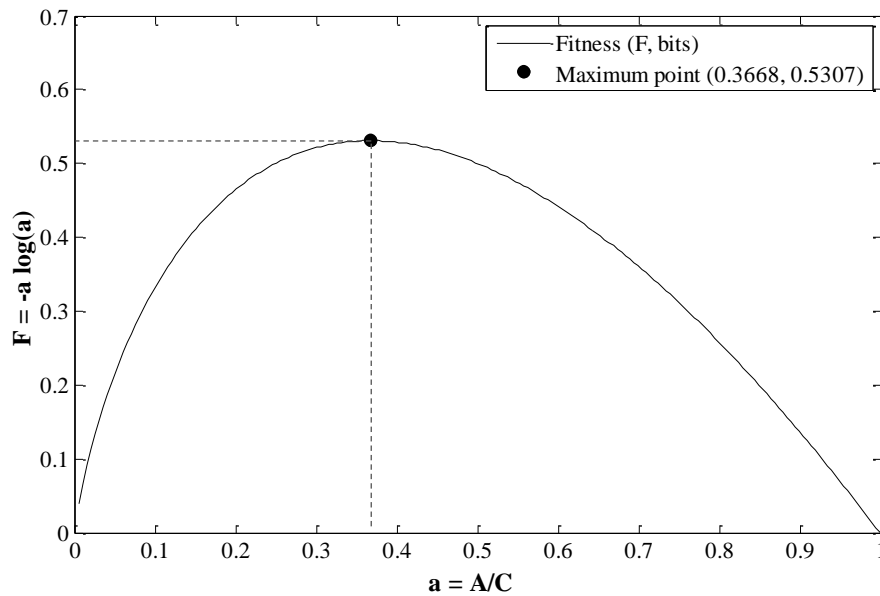
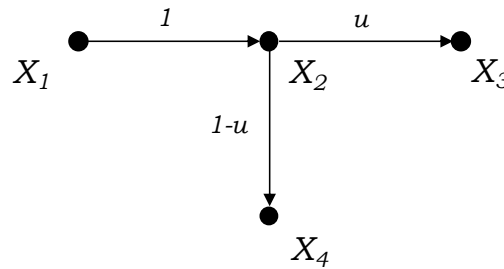
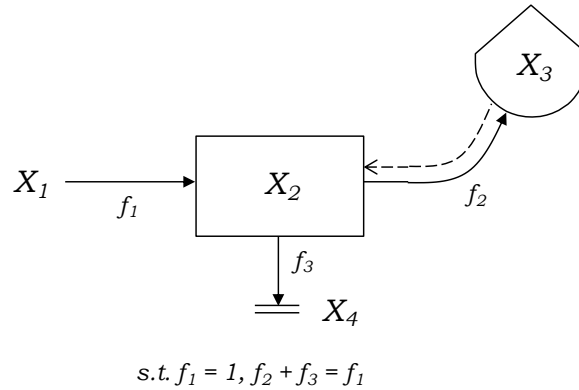

Fig. 3.11 Curve of system fitness and its maximum value: This graph shows an optimal ascendancy or a capacity can be proposed for maximizing the potential of system evolution. For the maximization of a fitness value, an intermediate system component becomes a critical player.



(a) System representation: system diagram (upper) and digraph (below)

Efficiency, u (%)	AMI	A	C (H)	L	F
0	1	2	2 (1)	0	0
10	1	2	2.47(1.24)	0.24	0.25
20	1	2	2.72(1.36)	0.36	0.33
30	1	2	2.88(1.44)	0.44	0.37
50	1	2	3.00(1.50)	0.50	0.39
70	1	2	2.88(1.44)	0.44	0.37
80	1	2	2.72(1.36)	0.36	0.33
90	1	2	2.47(1.24)	0.24	0.25
100	1	2	2(1)	0	0

Note: (1) A: Ascendancy, C: Capacity, F: Fitness $(-(A/C) \log (A/C))$, where T is a system throughput), (2) When $f_2 = 0.9$ and $f_3 = 0.1$, then the system efficiency equals 10% (2) In this case, fitness is the same as robustness (R). (3) Measures are all for the internal organization (i.e., no external import and export).

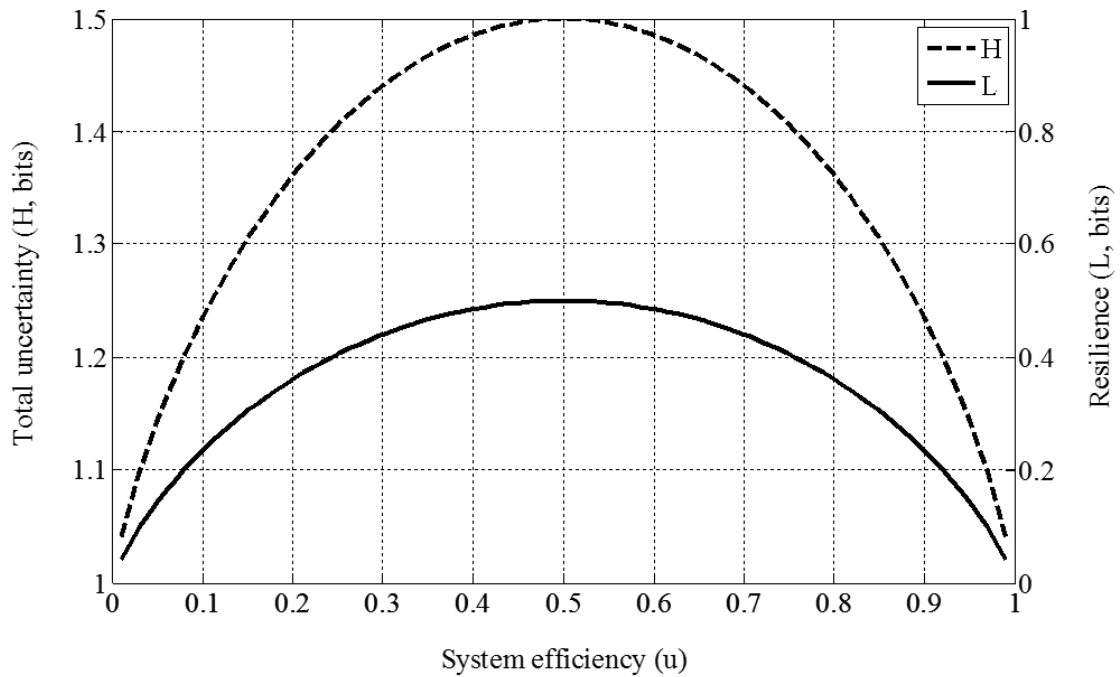

(b) Test result of system attributes (resilience and total uncertainty)

Fig. 3.12 Test of the measure of resilience (and robustness): Results show the degree of resilience is consistent with the maximum (em)power principle in steady state development.

(C) Reconciling stock and flow-focused measurements

H.T. Odum’s descriptive term for a sustainable ecosystem construction, “self-rewarding loop (Odum 1971)”, recalls the Ulanowicz’s “autocatalytic” reaction. Most of Ulanowicz’s arguments about the resilience of a network configuration is similar to Odum’s energy principles of compromise efficiency and maximum (em)power, and the postulates on resilience could also be understood as embracing Odum’s principle. Although he does not make a direct correlation to the Odum’s statements on maximum power,³⁴ theoretical consistency can be found by a simple experiment,

³⁴ Ulanowicz emphasizes that ascendancy synthesizes E.P. Odum’s 24 attributes of ecosystem development (Odum, 1969), and then he puts it, “Optimal ascendancy translates into maximal work, when the medium of interest is energy (Ulanowicz, 1986).” Although Ulanowicz disagrees with H.T. Odum’s maximum power at 50% efficiency (Ulanowicz, 1980), by extending his arguments, when the medium changes to emergy, optimal ascendancy represents maximal empower. However, a problem involves our understanding of optimal ascendancy. In a benign condition (also in a steady state), system ascendancy reaches its full (maximum) potential at optimality so that the ascendancy theorem perfectly works with maximum (em)power principle. Nevertheless, such maximal tendency should be compromised in an external disturbance or severe environment, then, consistency of the two principles becomes undermined. An increase of ascendancy is influenced by compartmentalization (i.e., specialization and internalization) as well as attributes of the flow configuration (i.e., concentration and cycling).

shown in Fig. 3.12. Suppose a thermodynamic system is in a steady state development. Then, the system's energy transformation processes are aggregated into a single compartment (X_2) so that it simplifies this theoretical test. This system has three energy pathways: inflow (f_1), outflow (f_2), and degradation (f_3). Let X_1 , X_3 , and X_4 denote a source, a storage (or a consumer), and a sink respectively. The system operation can be depicted as a digraph (Fig. 3.12 (a)), and the system efficiency is computed by f_2/f_1 , denoted as u . Since the system is steadily working, f_1 shall equal $f_2 + f_3$.

To parameterize each of the flows with the efficiency, let the input be a unit flux. Then, f_2 and f_3 are denoted as u and $1-u$ and total throughput becomes 2. Now, we can calculate the informational indicators (A, C, ϕ , and F) in various magnitude of efficiency by altering the values of f_2 and f_3 :

$$\text{AMI} = \frac{1}{2} \log_2 2 + \frac{u}{2} \log_2 2 + \frac{1-u}{2} \log_2 2 = 1$$

$$H = -\left(\frac{1}{2} \log_2 \frac{1}{2} + \frac{u}{2} \log_2 \frac{u}{2} + \frac{1-u}{2} \log_2 \frac{1-u}{2}\right) = 1 - \frac{u}{2} \log_2 u - \frac{1-u}{2} \log_2 (1-u)$$

where $0 \leq u \leq 1$.

The results are presented in Fig. 3.12 (b). Interestingly, it shows that fitness (F) is maximized when the efficiency reaches a mediated level (50%), while A/C becomes minimized. Since the directions of pathways and total throughput are fixed ($f_1 + f_2 + f_3=2$), AMI and ascendency are constant. But one can notice that the system capacity (C) is variable, and also maximized at 50% efficiency.

The fixed value of AMI and ascendency implies a network constraint that the size (throughput) and the number of effective pathways of the system organization are constant. In this condition, the only way of system development is to increase flow diversity (uncertainty of information content). The diversity of quantum flows is ensured with an assumption of growth in steady state without any external perturbation, which is a fundamental premise of the maximum power principle.

For these reasons, as Ulanowicz (1980) suggests, behavior of the ascendency's optimality is not yet clearly revealed, and it shall be an interest of further study. Ulanowicz (1986) finally states, "*It is inappropriate to compare competing descriptions for the purpose of deciding unequivocal acceptance or rejection. Just as a phenomenological statement cannot be completely verified, neither can it be entirely falsified.*" This dissertation takes only theoretical utility of ascendency and the emergy metrics to discuss a holistic system configuration under steady-state system development.

Even if the system size growth is limited, an increase of capacity means a gain of uncertainty in the identification of the system configuration. That is, the system networking becomes highly sensitive to the position and intensity of a single particle of a flow pathway. If the “usefulness” and “quality” highlighted in the description of the maximum (em)power principle can be interpreted as equivalent to “significance” of a single energy particle’s contribution to the overall energy transaction, then this case suggests that the concept of resilience based on the network examination and the maximum (em)power based on the input-output analysis are, inevitably, two sides of the same coin.

(D) Understanding the relationships between the informational performance measures and system efficiency

This is an advanced extension of Ulanowicz’s experiment (Appendix F) for the purpose of an enriched understanding of hypothesized relationships between information-based measures of system performance. To generalize the results of Appendix F, consider the following multi-compartment system with one-way flow of a medium (energy or mass), so that the topology represents the general case of an open-loop biological system (Fig. 3.13).

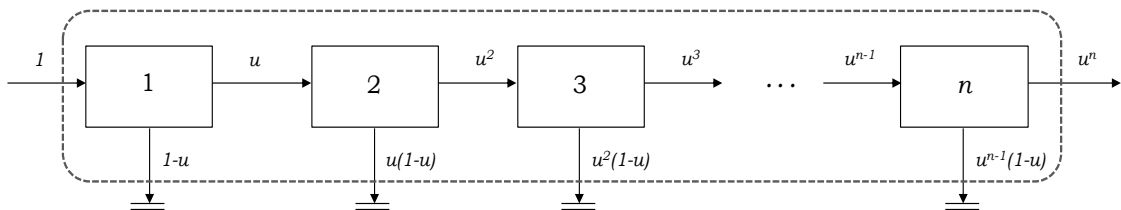

Fig. 3.13 General structure of a one-way flow system with n compartments

This complex model consists of n system compartments. No export, import, and backward flows are considered for the system work to mimic the chain network of a trophic system in a simple scheme. We set the efficiency of each unit compartment (trophic efficiency) equal, and denote it as u so an output of a single compartment is the multiplication of u and an input to the compartment. Limiting our discussion to the steady-state flux, i.e., gain and loss at each node are the same, if 1 is an initial input to the system, the total flow transaction eventually gives a useful medium of u^n

from the n -th compartment. Hence, the efficiency of the entire system is measured u^n . A unique parameter of the flow topology is the efficiency value. Total system throughput (TST, T_n) is the sum of all individual values on pathways such that:

$$T_n = 2 + u + u^2 + \dots + u^{n-1}$$

And system complexity, AMI, and resilience are computed by:

$$H_n = \log(T_n) - ((u^2)' + (u^3)' + \dots + (u^n)' + u^n) \frac{1}{T_n} \log(u) - (1 - u^n) \frac{1}{T_n} \log(1 - u)$$

$$AMI_n = \log(T_n) - (1 - u^n) \frac{1}{T_n} \log(T_n - 1) - (u^2 + 2u^3 + 3u^4 + \dots + (n - 1)u^n) \frac{1}{T_n} \log(u)$$

$$L_n = \frac{(1 - u^n)}{T_n} \log \frac{T_n - 1}{1 - u} - \frac{2 \log(u)}{T_n} \left(u + u^2 + u^3 + \dots + u^{n-1} + \frac{2 - n}{2} u^n \right)$$

System ascendancy and capacity are calculated as,

$$A_n = T_n \log(T_n) - (1 - u^n) \log(T_n - 1) - (u^2 + 2u^3 + 3u^4 + \dots + (n - 1)u^n) \log(u)$$

$$C_n = T_n \log(T_n) - ((u^2)' + (u^3)' + \dots + (u^n)' + u^n) \log(u) - (1 - u^n) \log(1 - u)$$

Fig. 3.14 exhibits variations of the system-level attributes and information indices according to variations in the number of compartments and the efficiency of each compartment within the test flow chain. In Fig. 3.14 (a)~(c), we observe that TST, AMI, ascendancy (A), and capacity (C) increase proportionally to the number of compartment and the efficiency, while complexity (H) peaks at an intermediate efficiency level and decreases. It is noticeable that TST exponentially increases after a certain level of efficiency, and this trend becomes intensified as the system adds compartments. Also, ascendancy variation shows a similar trajectory. This result reveals that a system grows with an increase in individual compartmental efficiency,

and augmentation of the scale of flow quantity has a strong leverage to that of ascendency.

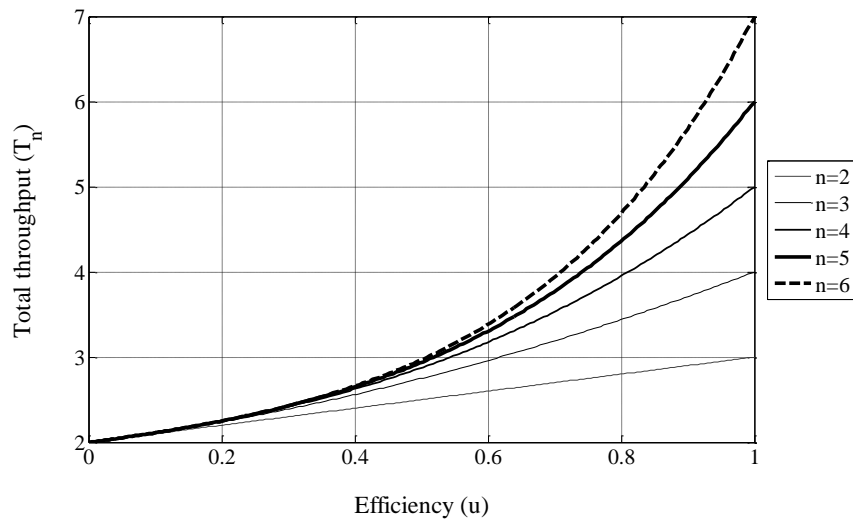

(a) Compartment efficiency and system throughput

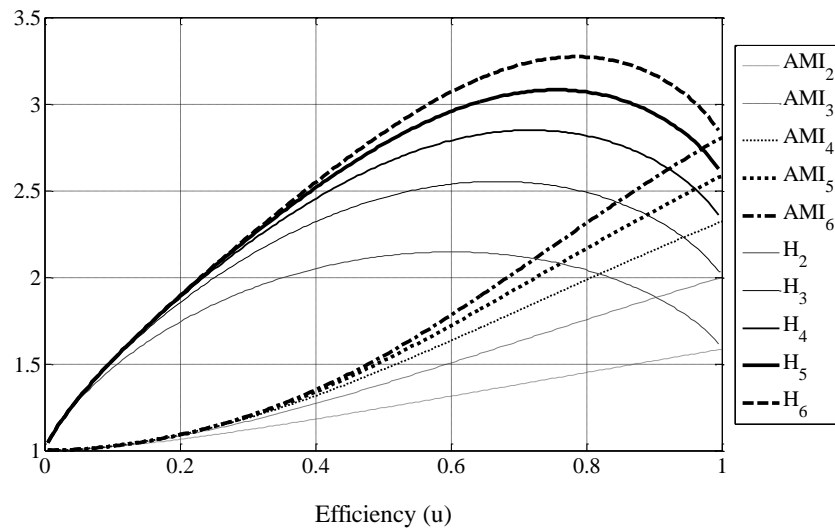

(b) Compartment efficiency and average mutual information (AMI) and complexity

(H)

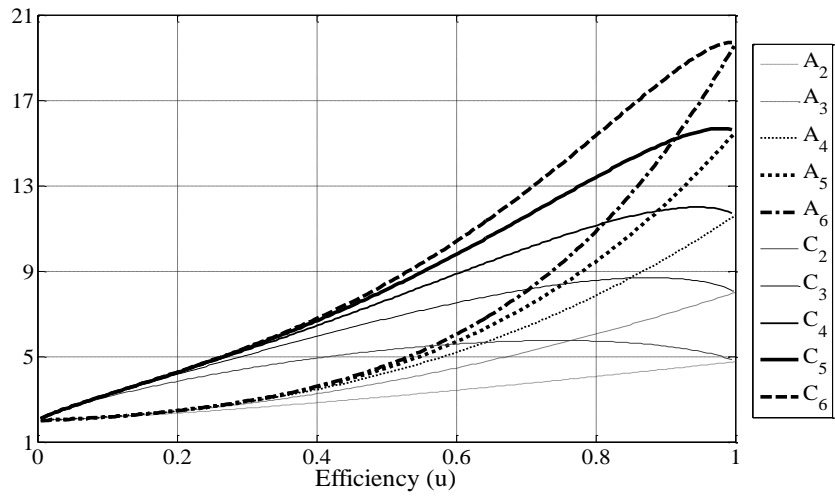

(c) Compartment efficiency, ascendency (A), and capacity (C)

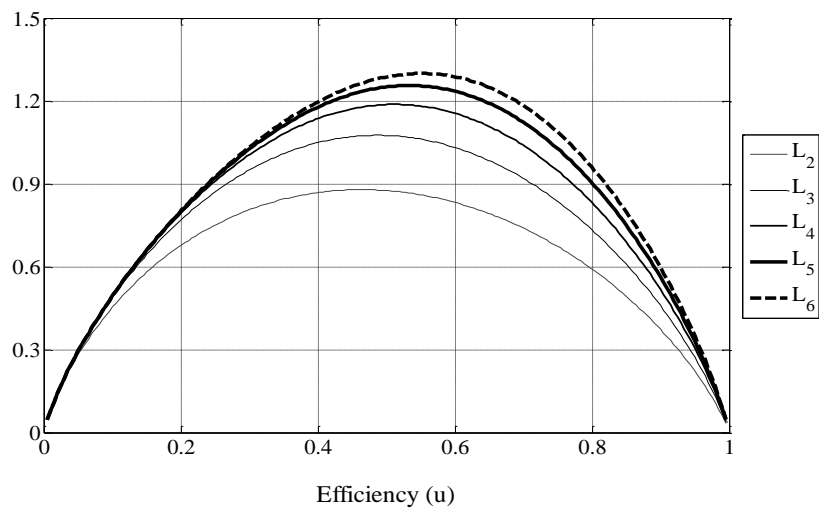

(d) Compartment efficiency and Resilience (L)

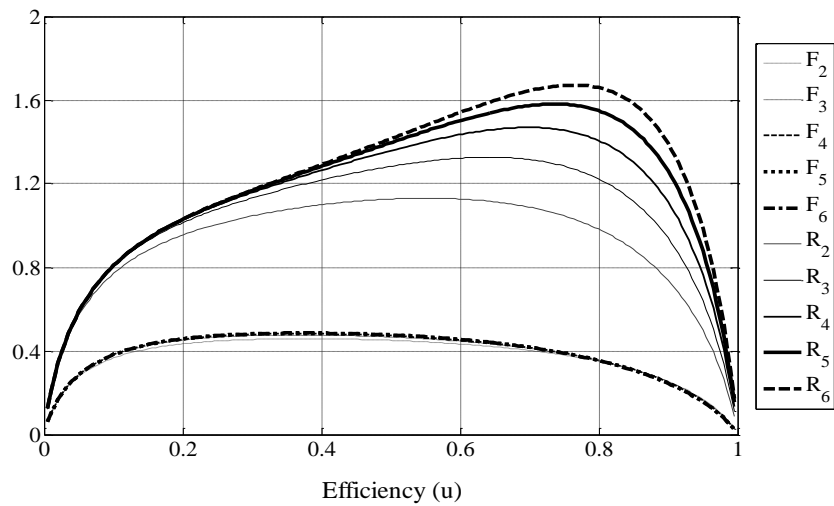

(e) Compartment efficiency, fitness (F), and robustness (R)

Fig. 3.14 Compartment efficiency (u) and information indices

It is important to notice that AMI increases in parallel with the efficiency, because it substantiates that AMI is a surrogate of network-based efficiency. By definition (Shanon, 1948; Ulanowicz, 1986), AMI refers to a system's retaining ability of quantum on the pathways. Since greater compartmental efficiency ensures that more initial inputs stay all the way through the flow structure, we identify that a longer chain of a resource flow with high efficiency augments AMI. These phenomena are consistent with our conventional (mechanistic) understanding that increased efficiency followed by energy conservation assures system growth (greater TST) and development (greater AMI), as if it underpins that system sustainability gain advantage solely from thermodynamic minima (reduction of energy loss and greater efficiency). However, the profile of system complexity (H) and ecosystem indices pertaining mainly to system stability (resilience, fitness, and robustness) tell us that the system is likely to be unstable if the efficiency increases excessively (Fig. 3.14 (d) and (e)). Complexity profiles in Fig. (b) roughly follow the findings from the experiment with the single compartment model. Complexity (a proxy of system power) is maximized at about 50~80% efficiency, even though peak points of efficiency move up as the system expands.

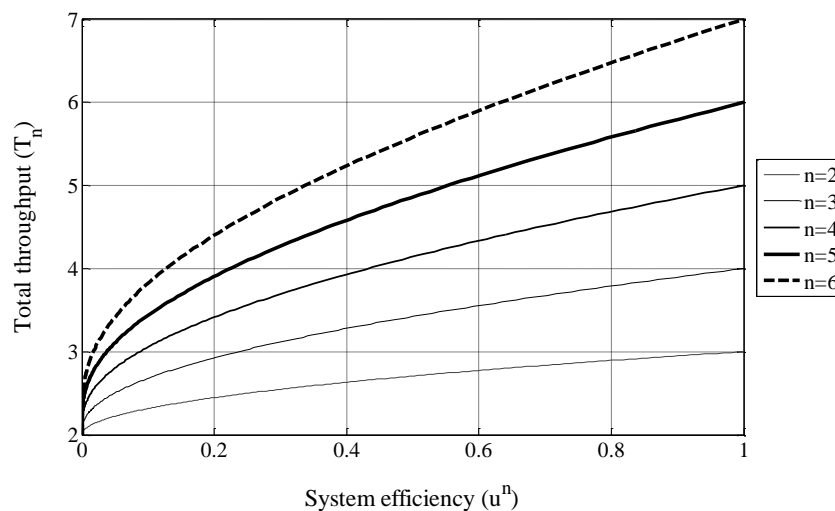

(a) Whole system efficiency and system throughput

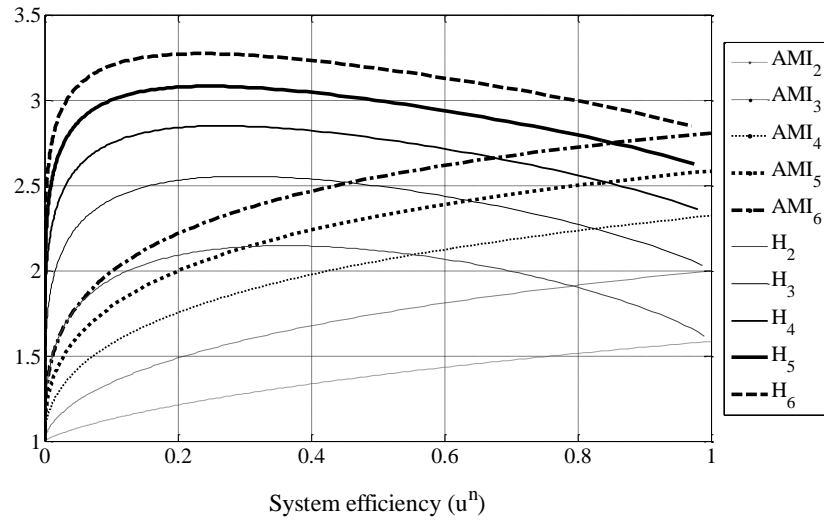

(b) Whole system efficiency and average mutual information (AMI) and complexity

(H)

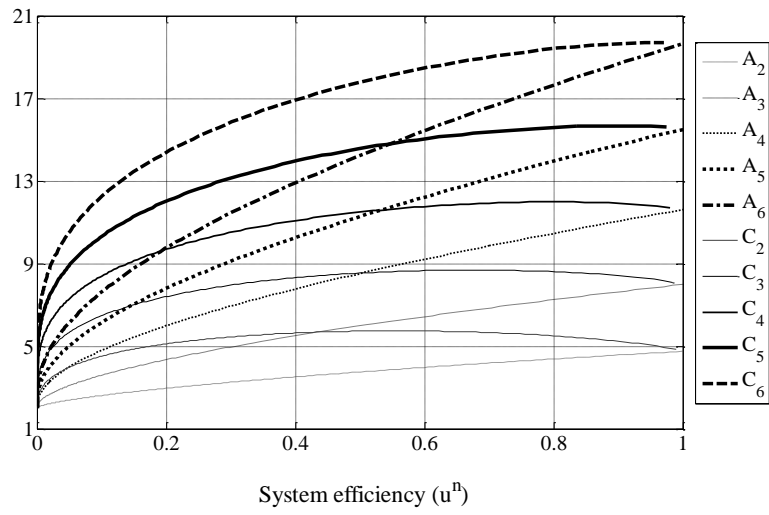

(c) Whole system efficiency, Ascendency (A) and Capacity (C)

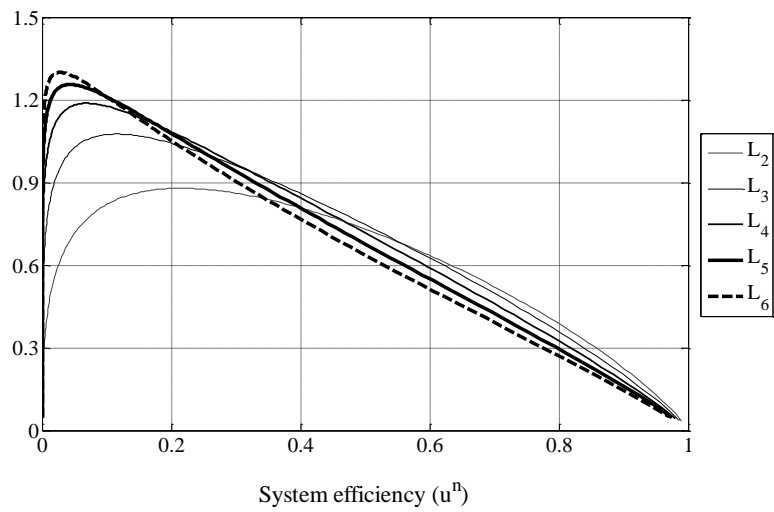

(d) Whole system efficiency and Resilience (L)

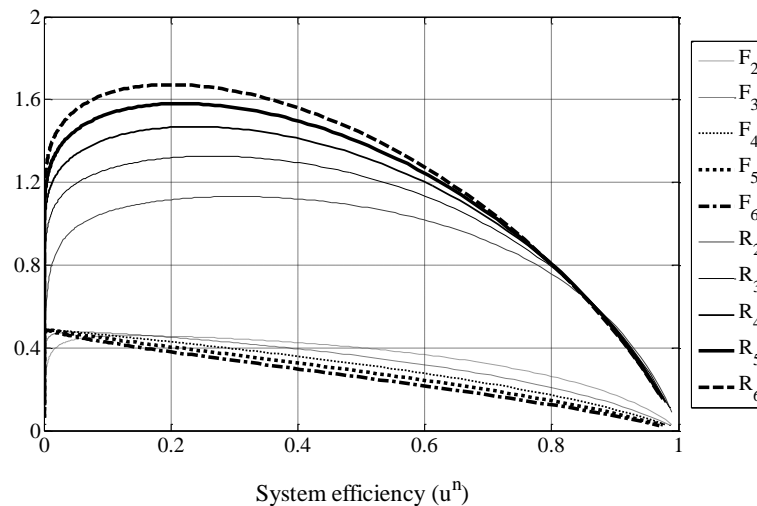

(e) Whole system efficiency and fitness

Fig. 3.15 System efficiency, AMI, fitness, and robustness (bits)

In Fig. 3.14, Resilience (L) profiles look similar to complexity (H), but maximal values appear within a narrow and lower range of efficiency. Fitness (F) is maximized relatively earlier at around 20~30% efficiency, when the system is under development (lower AMI and H). It proves that an environmental system is likely to be more flexible (adaptable) before it is fully organized (structuralized in flow network configuration). It is interesting to observe that system robustness increases along with the increase of capacity and sharply drops after a peak point.

These findings clearly show that augmentation of compartmental efficiency is not always conducive to the intensive system-level properties such as system's power accumulation, potential of reorganization, adaptability to environmental change, and resistance to perturbation (strong forcing function from the external sources). In order to identify that an external observation of efficiency acquires with the above findings, indices are coordinated with the whole system efficiency (u^n) (Fig. 3.15).

Interestingly, the increasing tendencies of TST and AMI at high efficiency slow down. System complexity (H) increases with growth of the system. However, comparing to Fig. 3.14, H is maximized around a far lower level of efficiency (about 10~30%), and the efficiency of maximum uncertainty moves down as compartments are added (system growth). This finding makes sense along with the fact that ecosystems trophic level efficiency is often around 10% or less. The system grows with increased number of compartments and fluxes, but slowdowns of the AMI and

capacity increase show that increased efficiency sets a certain limit on the system development. Similar to the complexity trajectory, resilience, fitness, and robustness are also maximized at low efficiency and this trend tends to be intensified as the system flow network is more complicated (Fig. 3.15 (d) and (e)).

From the whole system perspective, thus, system descriptions of internal states can be very different, because the whole system efficiency does not parallel compartmental efficiency. Accordingly, it turns out that AMI is network efficiency but it should be distinguished from the efficiency of a unit process. Lowering system efficiency for greater AMI looks incompatible with the general notion of sustainability.

Nevertheless, as shown in Fig. 3.16, system efficiency and AMI have an inverse correlation, since total efficiency of coupled compartments is, according to the SLT, always less than that of a unit transfer. Looking back into Fig. 3.15 (b), it is clarified why a developing system sacrifices efficiency. The six-compartment model is far less efficient than the two-compartment model, but, in general, natural adaptation will prefer the six-compartment system because it has greater potential of carrying power (higher uncertainty in source selection, H). That is, this test implies that *system development goes through a trade-off between efficiency and complexity*. Higher complexity means less efficiency. However, the degrees of the complexity are not limitless, yet they are clearly bounded, as less efficiency (or too much AMI) results in lesser power (Fig. 3.14). At this point, it recalls the Ulanowicz's statement that maximum AMI is not desirable for self-organizing ecological communities and, so, an ecosystem in a steady state would find an optimal level of system efficiency and AMI to increase fitness, resilience, and power.

To summarize the terms of information indices, the ratio of AMI and H (AMI/ H) refers to developmental (organizational) efficiency of system flow networking, while system complexity is a proxy of the potential developmental power. Resilience and fitness are significant attributes for examining developmental adaptability. However, increasing tendencies of H and L do not necessarily coincide (Fig. 3.17). A complex system network tends to have greater H and L , but they are maximized at different developmental levels. Therefore, we can suppose that an environmental system maximizes resilience when increasing power is not available with current resource availability. The system status can move back and forth between maximum power and maximum resilience, by switching priority depending on an external thermodynamic

constraint. Nevertheless, it is clear that a general tendency towards sustainability is to increase both.

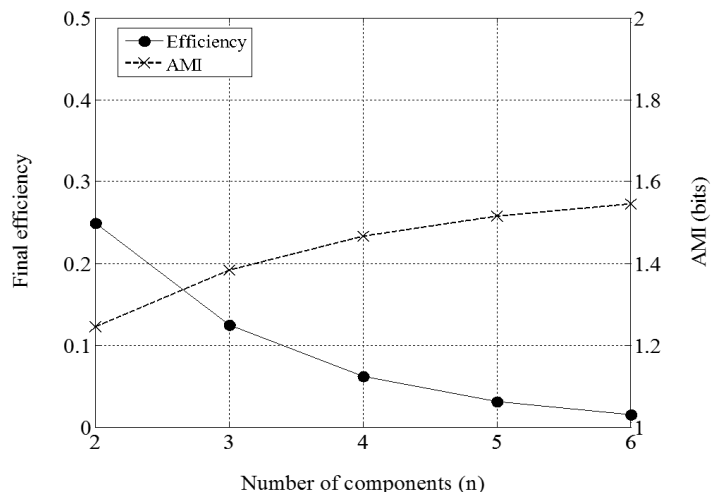
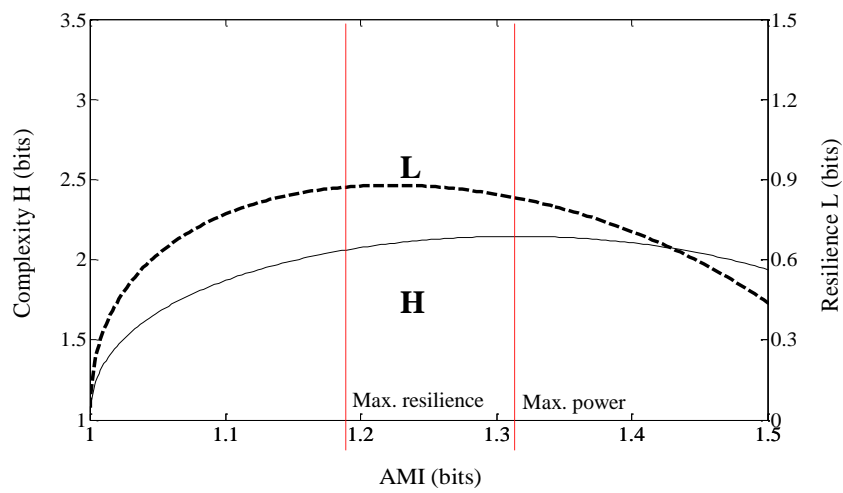
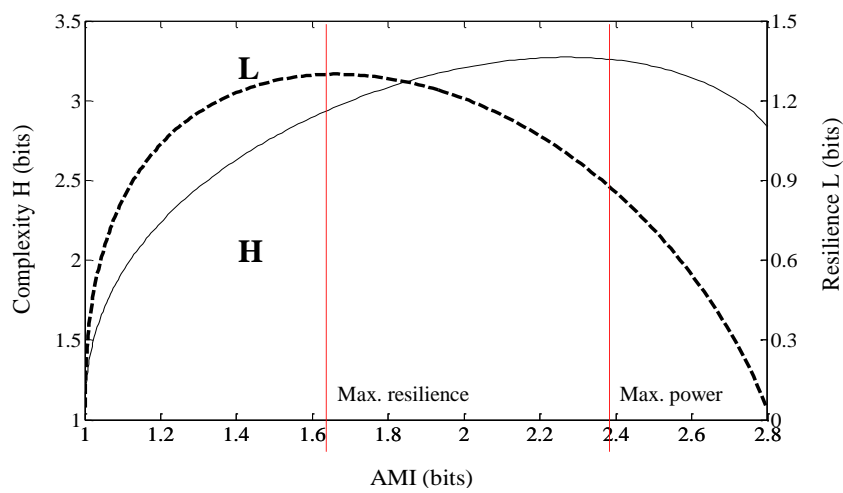

Fig. 3.16 Final system efficiency and AMI



(a) Two-compartment model



(b) Six-compartment model

Fig. 3.17 Variation of complexity (H, total system uncertainty) and fitness

3.3.3 Application of an ecological understanding to building systems

3.3.3.1 Pros and cons of the eco-centric approach

This dissertation attempts to demonstrate that the ecosystem principles (maximum power, increasing fitness and resilience, and optimal efficiency) are applicable at a building scale and to different types of building systems. However, even though the thermodynamic principles obtain generality in many disciplines, and also provide a great deal of advantages in the description of causality of system events, conceptual utility of ecological principles and appropriate interpretation of mathematical measures have been demonstrated primarily by empirical evidences of natural environment. Some hypotheses for thermodynamic understanding are also structured with “phenomenological” terms. For these reasons, they do not always align with outright acceptance. Paul Stoy (2010) criticizes that, to some extent, “all ecosystem theories are: (i) overly abstract, (ii) oversimplified, (iii) not universally applicable, or (iv) too difficult to test.” In effect, the Odum’s maximum (em)power principle does not articulate a full insight for development in harsh environment and a dynamic setting (i.e., scarcity of resources and disturbance) (Odum and Pinkerton 1955; Stoy 2010; Ulanowicz 1980). Ulanowicz’s ascendancy principle also draws a limit due to (i) lesser number of rigorous empirical tests and (ii) selection of flow metrics³⁵ (Odum 1996). Admittedly, both theories rely on a network construction, which suffers from lots of uncertainty arisen mainly from (i) difficulty in estimating unknown medium values (parameter uncertainty) and (ii) modeling (there may exist some network pathways unknown to an observer.) (Ulanowicz 1986; Stoy 2010).

However, in spite of some disputes in the biological community and problems of data approximation and system modeling, a comprehensive biological view of sustainability provides an effective theorems and tools to newly and correctly apprehend building form and function. Even though the emergy and ascendancy theorems are primarily developed for living systems, those conceptual principles can be applied to building study, since growth and development are general phenomena in all environmental disciplines, regardless of temporal intervals or physical scales (Odum and Pinkerton, 1955; Ulanowicz, 1986). Even if the treatment of growth and

³⁵ Howard Odum mentions, “It is better to use emergy rather than energy (Odum, 1996).”

development as independent variables remains problematic, it is significant to notice that Eq. (3.9) ~ Eq. (3.12) couple external factors (T) and the internal factors (H, AMI), which agrees with our hypothesized equation for quantifying holistic building sustainability (Eq. 2.1). Depending on the type of a flow quantum (e.g., energy or mass) for the throughput parameter (T) and identification of information gain (H, AMI), we find Eq. (3.3) also strongly parallels it. This formulaic parallelism encourages the practical utility of informational indicators for the building sustainability assessment. Adaptation requires some technical treatment followed by theoretical articulation.

3.3.3.2 Pilot test: Hypothetical experiment on the generic building network model

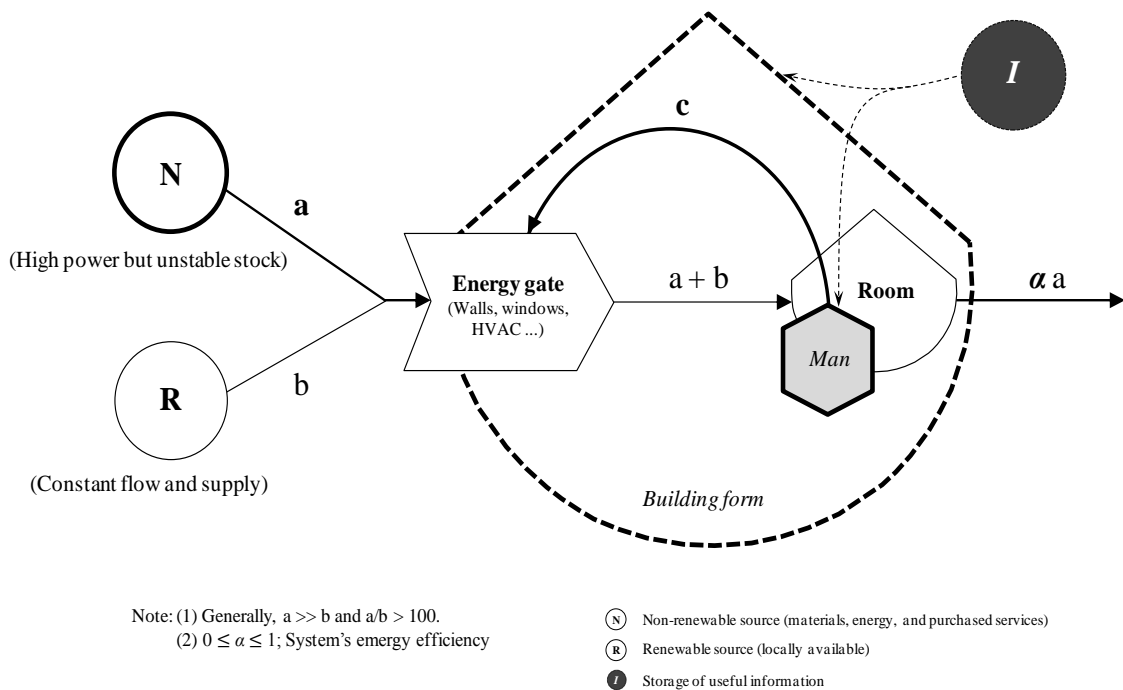

Fig. 3.18 Generic model of the building metabolic system: Information is a substantial environmental resource that is plentiful and readily available (thus, it functions as a surrogate of renewable source). However, the size and capacity of its storage are unknown, and cannot be measured directly. Information is measured only by observing changes in the configuration of flow networking.

Information-based ecosystem indices do not include the whole building's information content. They account for "thermodynamically useful" content of whole building information, so they identify system-level building performance and sustainability. It is by incorporating an emergy unit into the information indices, that building performance and sustainability can be characterized at the global-system level.

To verify applicability of ecosystem indices and system interpretations to building thermodynamics, the following generic building system was designed to emulate the metabolism of a living system as simply as possible (Fig. 3.18).

System design and parameters

This network model was designed to have primary building components only, and was drawn with Odum's emergy diagram symbols. Flow quantity over each path indicates the emergy value of each flow. Most physical elements that are in charge of building energy transactions (e.g., building façade, mechanical equipment, windows, doors) were lumped into a single component named energy gate. It was assumed that the building has three categories of environmental sources: renewable (R) and nonrenewable (N) that include both energy and matter and information (I). However, despite its importance, building information is accumulated from a storage whose capacity and location is unknown. So, this model monitors pattern changes of the emergy flow networking to detect its effects. This is because (1) information content is only measured by observing the change in system organization; (2) the two external sources (R and N) have distinctively different characteristics (stock-constrained and flow-constrained); and (3) this test aims in part to demonstrate that information-based performance indication is not incompatible with the common notion of building sustainability (e.g., reduction of nonrenewable energy use). Emergy gained from the resource reservoir through the energy gate is transmitted to interior space (room and man), and computed as $a+b$ according to the emergy accounting rule. Behavioral interactions (opening windows, lighting control, etc.) that control the energy gate and any feedback from interior space to other building components were represented as a backward flow (c). The building system yields a useful product, but it can be varying depending on the (emergy) efficiency of the space. As for the system, total system throughput (TST, T) is a function of four parameters and computed by adding up all

flow quantities such that:

$$\mathbf{T}(a, b, c, \alpha) = (2 + \alpha)a + 2b + c$$

And H, AMI, and resilience are calculated respectively as follows:

$$\mathbf{H}(a, b, c, \alpha) = \log T - \frac{1}{T} \{a \log a + b \log b + c \log c + (a + b) \log(a + b) + \alpha \log \alpha\}$$

$$\mathbf{AMI}(a, b, c, \alpha) = \log T - \frac{1}{T} \{(a + b + c) \log(a + b + c) + (c + \alpha) \log(c + \alpha) + (a + b) \log(a + b) - c \log c\}$$

$$\mathbf{L}(a, b, c, \alpha) = \frac{1}{T} \{(a + b + c) \log(a + b + c) + (c + \alpha) \log(c + \alpha) - a \log a - b \log b - 2c \log c - \alpha \log \alpha\}$$

System ascendancy and capacity are calculated by multiplying AMI and H by the system scale (T).

Test results

In order to identify the influence of each parameter and their contribution to building sustainability, tests were conducted with variations of individual parameters (Fig. 3.19 and 3.20). First, to confirm the consistency of information-based examination and the general notion of building sustainability, information profiles were observed by changing the nonrenewable source import (a) with other parameters fixed (Fig. 3.19 (a)). Results show that reducing nonrenewable source use triggers an increase of complexity (H), i.e., system power, while adjusting AMI to a lower level. Another sign of sustainability is an increase of fitness. We can observe that both complexity and fitness sharply increase as the system self-organizes to significantly reduce nonrenewable energy flows. Similar trends are found with activation of feedback flows (c). In Fig. 3.19 (b), feedback increments cause the system to have greater power (H) as well as greater fitness with low AMI. This means that an engagement of the feedback loop in system networking (e.g., human activities for

building energy control) contributes to achieving sustainability. That said, it is noteworthy to see that the system may collapse if the feedback is excessive beyond input quantity. Fig. 3.19 (c) shows that increased energy efficiency (α) is conducive to gain greater power (H). However, as opposed to the previous tests, it helps to augment system organization (AMI), whereas it decreases adaptability (fitness). It tells us that appropriate partitioning of export and feedback would be significant in determination of a degree of sustainability.

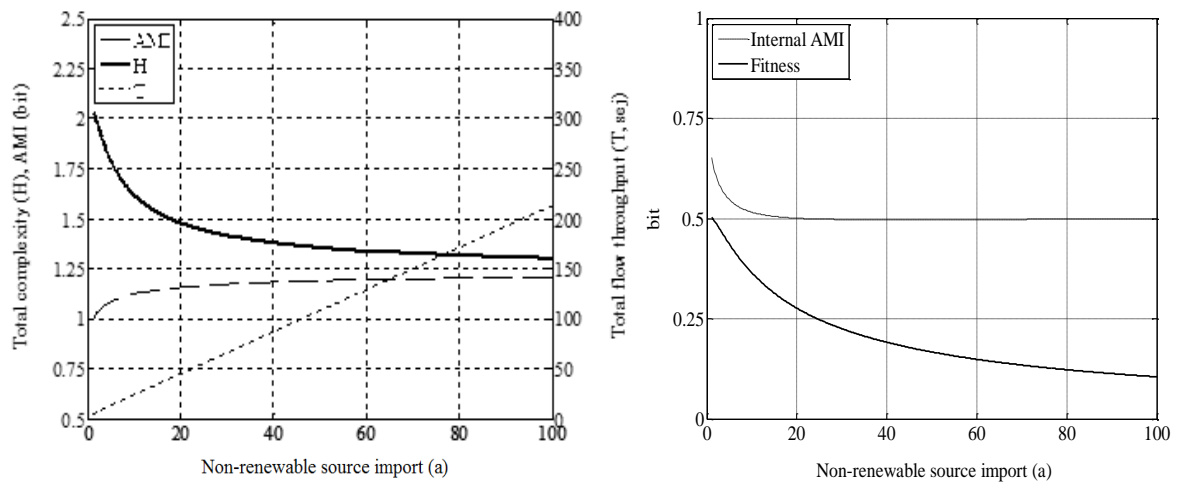

(a) $a=[1,100]$, $b=1$, $\alpha=0.1$, $c=1$

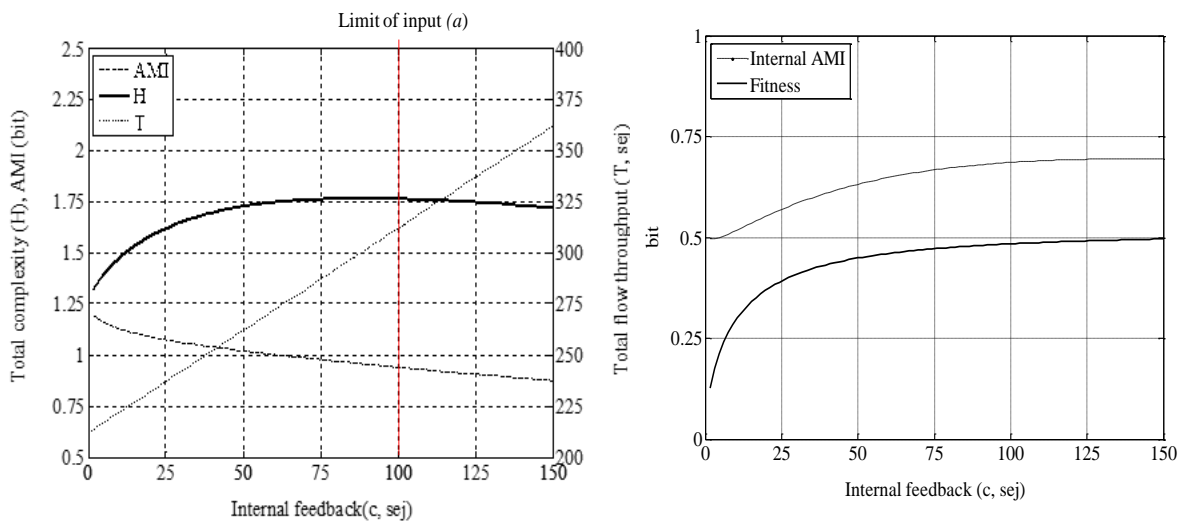

(b) $a=100$, $b=1$, $\alpha=0.1$, $c= [0, 150]$

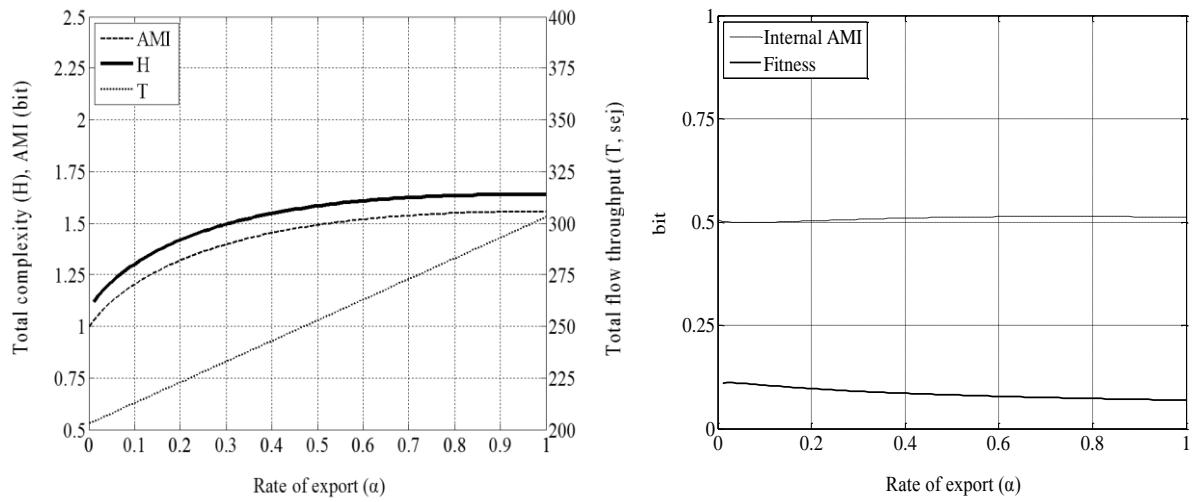

(c) $a=100, b=1, \alpha=[0,1], c=1$

Fig. 3.19 Results of the pilot test

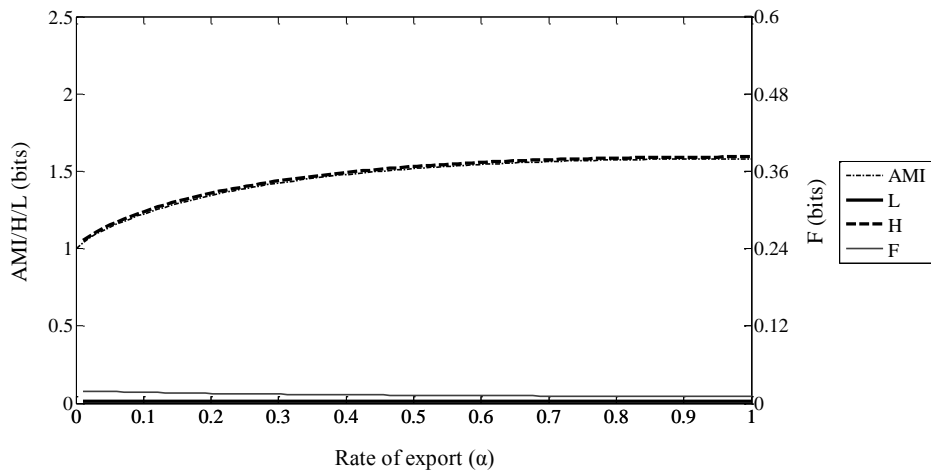

(a) $a = 1000, c = 1, b=1$

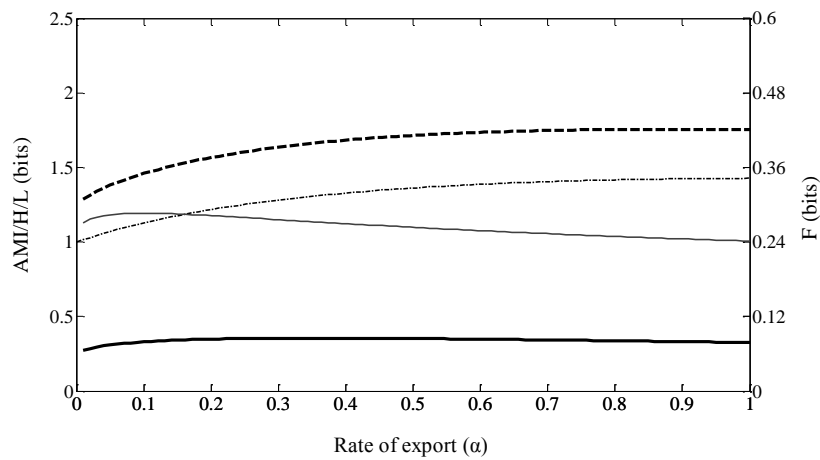

(b) $a = 200, c=20, b=1$

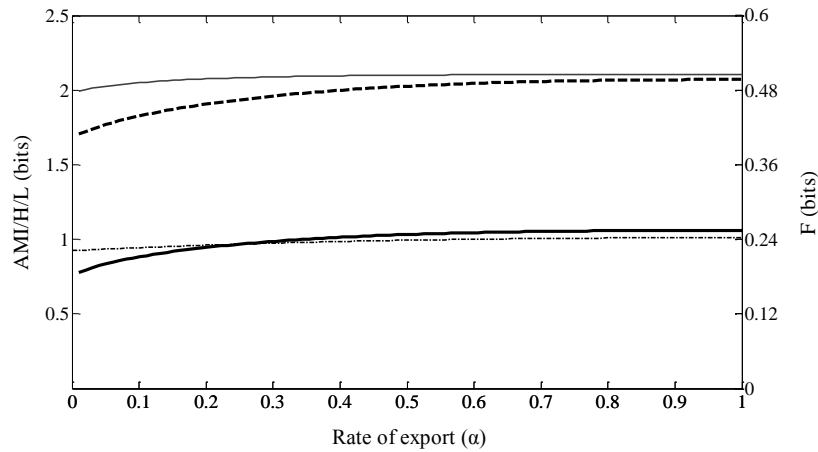

(c) $a = c = 20, b = 1$

Fig. 3.20 Results of the pilot test: Export rate and information change

Findings from Fig. 3.19 demonstrate that reduction of nonrenewable source use, increment of internal recycling or feedback, and greater export rate contributes to maximizing system power and sustainability. It is consistent with the ecosystem-based argument of sustainability that “a self-organizing mechanism that eliminates any one pathway from being more limiting than others is contributable to the maximum processing of the available energy (Odum, 1995; Hall, 2004)”, because, by definition, greater complexity (H) refers to greater uncertainty in source selection and flow distribution.

MePP coherently works for examining performance and sustainability of natural systems, for they do not use nonrenewable sources for development in general. Application of the principle to built environment, however, seems to be incompatible. In other words, in terms of ecosystem development, it is contradictory to define a building of reduced fuel use as a sustainable system, because it is likely to carry low power. However, as hypothesized, by incorporating information as a significant environmental source of the building, MePP clearly accounts for this paradox. Even if we do not perfectly clarify the origin and capacity of building information sources for now, it is a high-quality (large transformity), almost limitless, and quasi-renewable source (Odum, 1988). Building energy reduction due to an environment-conscious control, accordingly, justifies a far greater energy inflow and greater empower involving information. By the same token, it can be assumed that even though the building system undergo a TST decrease (without presence of information), system

complexity (H) can increase as an indication of system development and sustainability, because, in effect, reduction of flow quantity from the renewable and nonrenewable source is not possible without an increase of information. Then, it eventually turns out that the building ends up having an increased TST and capacity (N+R+I). The presence of information in the processing of energy reduction can be proved by activation of the feedback loop (particularly an increase of resilience that highlights potential human intervention in flow networking).

Fig. 3.20 demonstrates this assumption. Having the renewable source flow constant as a unit quantity ($b=1$), we identify that an increase of the feedback flow (c) to 20 with decreased nonrenewable flows (a; from 1000 to 20) eventually leads to a higher state of system resilience at the expense of efficiency (AMI). In terms of network configuration, resilience shows that securing redundant flow pathways (making the system more complex) is desirable to increase power (from information) rather than creating an efficient (autocatalytic) connection. Since resilience and adaptable stability concern the accumulation of information content, utilizing an information source could be a very effective type of development, especially when environmental conditions are so stressful that amount and sorts of resources are limited to choose.

CHAPTER 4

DEVELOPMENT OF AN INFORMATION–EMERGY INTEGRATED BUILDING MODEL AND ASSESSMENT METHOD

4.1 General rule of model development

4.1.1. Rules and theories of system modeling

In general, system modeling is suggested for (i) overall description of a problem, (ii) articulation of synthetic information, and (iii) quantification of complex system behavior (Jørgensen, 2009). Janssen et al. (2006) recognize the usefulness of the network-based modeling in the quantitative evaluation of a socio-ecological system because system level properties are characterized by a dynamic description of the system structure and the interactive variation between the systemic entities. Nonetheless, decision-criteria for the qualification of a system actor (component) and the level of system resolution (i.e., complexity of connectivity and the number of nodes and paths) remain unclear to setting up a building system model for this study.

In the previous chapter, the generic model structure of a building ecosystem was proposed as a complete conceptualization of schematic energy networking conceived by the order-disorder transition of biological nutrients (Fig. 3.3). However, the lumped metabolic pathways of the base model need to be subdivided for higher resolution of system observations so that the model is both descriptive and predictive at macro/micro levels: i.e., description of specific system behavior at an assembly level and prediction of the effect of design element changes into the environment.

Multiple strategies and guidelines regarding ecosystem modeling have been recommended. Costanza (1996) notably suggests, in his discussion of ecological-economic modeling, that three basic criteria shall be considered for the selection of modeling parameters and state variables and the representation of system organization; they are (i) realism, (ii) precision, and (iii) generality. Realism and generality are concerned with configuration of model structure as well as selection of elements. Precision depends on the reliability of inputs and outputs, and, thus, it is strongly

influenced by data quality, selection of variables. Finer space-time subdivisions of system configuration and parameters are known to guarantee realism and precision of the results, but no ecosystem model is a perfect representation of reality because it is implausible to study an ecosystem in its full complexity due to the enormous volume of data. So, it cannot help avoiding to some extent an aggregation that funnels large number of associative elements, variables, and parameters into fewer numbers of upper domains. The appropriate level of model detail is determined considering the purpose of analysis, but an optimal model construction is attained only at a balance point between simplification and refinement. To determine the level of simplification and refinement, two structural approaches based on algebraic manipulation are introduced for the ecological translation of a real system; i.e., (i) homomorphism and (ii) isomorphism (Schultz, 1969). The formal definition of homomorphism allows the additive union of system states, elements, or subsystems. So, Schultz (1969) identifies homomorphism as a simplified model. In the ecological literature, homomorphism is often described as an aggregation technique that considers any part of a system as a black box that can be joined to the system organization, while isomorphism is a non-aggregated modeling approach (Cale and Odell, 1979). Technically, isomorphism is a special form of homomorphism, which is valid if one-to-one correspondence is found between the model and the real system description. Accordingly, at a focus level, aggregation may not be necessary for the isomorphism, and, hence, it can map the real interconnections between system elements onto the model (Schultz, 1969).

4.1.2. Modeling procedure and components

Regarding the system modeling procedure, Jørgensen (2009) suggests five formulaic modeling components: (i) external variables (forcing functions), (ii) state variable (substance concentration in an organism), (iii) mathematical equations (formal descriptions of system processes), (iv) parameters (coefficients of the mathematical equations), and (v) universal constant (e.g., gas constant, atomic weights, etc.). However, an information-based building ecosystem model may not encompass all of these components, because energy-information concerns communicational flows, whereas external and state variables are in accordance with stock of energy/exergy. Mathematical formulation and parameters that directly refer to an environmental state (temperature, pressure, a constant of chemical composition,

etc.) are not necessarily revealed at the focal level of this study. So, the first task of building system modeling procedure is to define system boundary and components.

A building is comprised of a few physical assemblies where architects engage to design. However, even a single assembly has a large number of heterogeneous elements. For example, a wall is decomposable into external materials, structure, insulation, and window system units in which a number of smaller-scale individuals are identifiable and occasionally serve trade-off thermodynamic works. This combination of elements also leads to difficulty in the selection of characteristic processes among many interferences and linkages between the elements. For this kind of system, Jørgensen (2009) argues that elements and flows that contribute more than 5% of the total biomass should be included. Based on this idea, system modeling developed for this study attempts to include every energy/material/informational flows whose thermodynamic interactions are expected to influence outdoor/indoor environmental changes. However, given that the ultimate goal of this study is to provide architects/designers with a practical recognition of environmental information during design processes, criteria of the component selection include: (i) the object of decision-making in design work, (ii) major construction assemblies, (iii) explicit relation to building management and operation, and (iv) significant contribution to overall change of energy, material, or information (>5%).

Mathematical formulations are developed by incorporating Odum's energy calculation and the definitions of Ulanowicz's indicators (Chapter 3). Key variables are energy quantities of gas emission, energy, and material use that define the medium on each flow pathway. Transformities from energy references are considered constants for energy-information integrated formulas.

4.2 Development of building network models

4.2.1 Extension of the order-disorder model into the chain of mutualism

To further specify a model of building's environmental flows, the analysis needs to explore the environmental metabolism of internal energetic organization, with a clear awareness of the interlocked correspondence between the local system (building) and the global environment. Fig. 4.1 illustrates how mutual interactions of energy, material, and information transfers work within the hierarchical structure of the global

environment. Extending the context of our interest (Fig. 3.4) to the utmost level, i.e., geobiosphere, a building is recognized as a system that imports/exports useful resources for its own sustenance, thereby contributing the development of the global environment.

For a building system, most environmental resources other than natural production reservoir (plants, lands, and ocean) can be regarded as stock of disorder (S_d), since they are in a disassembled setting of a building form. Starting from the external renewable sources (e.g., solar energy), energy, material, and information flows self-organize through an environmental supply chain (forward flows). Each system component lives on the resources of low-level components, but this source-consumer relationship may be converted by activation of feedback flows. In this hierarchical structure, buildings are not at the highest trophic level, because metaphysical resources such as shared information (knowledge) or culture feed on what is generated from the buildings and civilized environment.

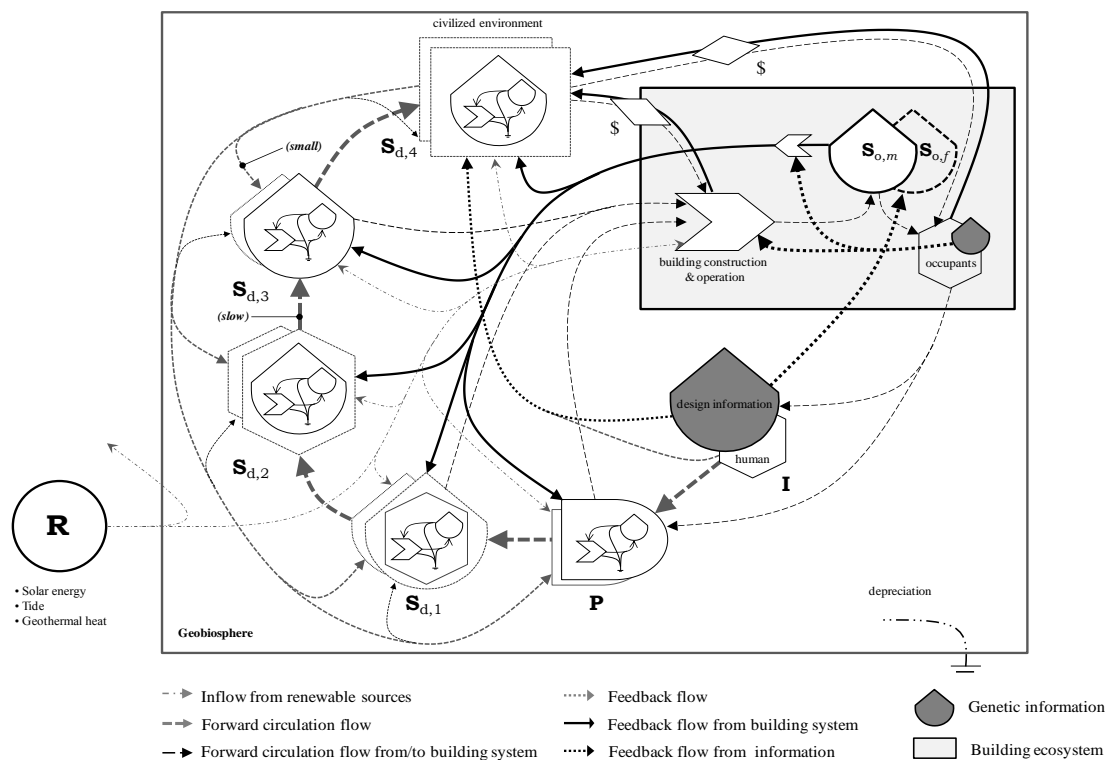

Fig. 4.1 Schematic global and building ecosystem model for environmental mutualism: (P: producers: plant, ocean, land, etc., $S_{d,1}$: inanimate consumers (wind, rainwater, etc.), $S_{d,2}$: animate consumers, $S_{d,3}$: fossil fuels, $S_{d,4}$: economy, industry, etc., I: shared information system, R: renewable resource)

Within the building system, feedback flow pathways can be created at every step and for every system component. It is important to note that feedback flows that contain energy and matter (e.g., material recycling, monetary flow from human productivity) are intensified by information. A building form is not only a material stock but also an organization of the material, so it carries an amount of information. During operational phases, occupant's decision-making manages "throttle valves" of energy gates (e.g., window opening, thermostat control). Based on an extended systemic understanding, we can notice that information describes the performance of the flow organization. Even if information could not be observed directly, useful information content can be identified by investigating energy and material flows across the building system.

4.2.2 Building network model of metabolism

Measurement of information content generally depends on system design. Systemic compartmentalization for the building model is based on the following specific factors: (1) if two building assemblies are exposed to different spatial and tectonic hierarchies, they belong to different components. For example, interior spaces and equipment do not belong to landscape. Building structure, floors, and walls strictly may not be within the same component, since their tectonic attributes are different. Nevertheless, it is contingent on the resolution of investigation; (2) the eco-systemic distinction between source, producer, and consumer originates from the energy hierarchy within the system. This definition is also applicable to subdivide building components; (3) a set of building elements and assemblies supported by similar energy sources are aggregated into a single component, since this study focuses on thermodynamic differences of energy quality; (4) it is assumed that elements of a component do not exchange effects with one another in generation/transmission of information.

Table 4.1 Categorization of metabolic compartments of building ecosystem

Node	Name	Description	Informational components	
			Energy-saving actions	Potential regeneration
N ₁	Dispersed heat	- Exterior heat dissipation		• Recovery of heat loss
N ₂	Yard and landscape	- Plants - Ground covering topology - Land-occupying equipment	• Minimization of topological exploitation • Natural habitat protection	• Regeneration of brown fields • Increase of recyclable footprint • Increased surface permeability • Self-energy supply devices (e.g., small building wind turbine, geothermal heat pump, etc.)
N ₃	Envelope/Structure	- Form and façade - Structural frames	• Air-tight construction • Aerodynamically-efficient form • High-performance insulation • High-performance glazing • Reflective exterior surface • Heat exchange units • Various passive technologies • Clean construction • Low-emitting material use	• Use of recyclable materials • Demolition management • Building integrated solar panels • Solar thermal collector • Rooftop/wall vegetation • Thermal mass (cooling/heating)
N ₄	Systems	- Space heating/cooling - Ventilation systems - Duct/pipe works - Electrical wiring - Indoor control system/Information grid	• maximum usage of renewable sources in generation • High-efficient HVAC systems	• Use of recyclable materials • Carbon offset facilities • Water-purifying device
N ₅	Interiors/Equipment	- Home appliances - Life-support utility - Domestic water use - Food consumption	• High-efficient consumer electronics • Use of eco-friendly domestic products/furnishings (e.g., low-carbon, recycled ingredients, etc.) • Efficient thermal comfort (e.g., thermostat, smart behavior) • Products from local industry • Reuse of rainwater • Indoor smoke control • Minimizing cultural disruptions	• Natural ventilation • Use of recyclable products • Contribution to social well-being • Formation of intellectual cultural capitals • Improving economic growth • Lowering infrastructural costs • Solid waste reuse (e.g., fertilizer, fuel source) • Gray water reuse (e.g., irrigation) • Environmental collective systems (e.g., effective underground drainage)
N ₆	Lighting	- Lighting fixtures - Lamps	• High-efficient fixtures/lamps • Automatic lighting control	• Use of recyclable materials
N ₇	Indoor heat/cool (Dispersed)	- Conditioned air volume of interior spaces		• Recovery of heat loss
N ₈	Occupants	- Building residents	• Thrifty activities	

Note: Table 4 References: [1] Asdrubali et al., 2015; [2] Balocco and Grazzini, 2006; [3] El Shenawy and Zmeureau, 2013; [4] Reza et al., 2014; [5] LEED: www.usgbc.org/credits

Table 4.1 shows the result of compartmentalization and lists the components. A building ecosystem consists of eight components that characterize dynamic transport

of heat and mass. Each of which is denoted by a node of the system network: (i) dispersed heat (ambient heat, N_1), (ii) yard and landscape (N_2), (iii) building envelope/structure (N_3), (iv) systems (N_4), (v) interiors/equipment (N_5), (vi) lighting (N_6), (vii) Indoor heat/cool (N_7), and (viii) building occupants (N_8). In addition to these internal compartments, the building system has external components outside the analysis boundary. I_R denotes renewable sources, I_N refers to nonrenewable sources, and E denotes external components of internal resources.

The useful information content that each compartment generates or transmits is estimated by identifying energy-flow reduction and/or potentials for regeneration, both of which are directly or indirectly associated with the development of feedback loops. As tested in Chapter 3, reduction of nonrenewable source import and feedback of energy and material contribute to increase information content of the whole building system. Identification of connections between components is pivotal in the construction of the network pathways. Table 4.2 lists potential energetic flows between internal components or exchanges between internal and external components. The flows are categorized into two types, i.e., forward transmissions from a low-grade to a high-grade component and backward flows that help regeneration of environmental sources. Flows in Table 4.2 identify all potential flows that are feasible to define complex building thermodynamics.

Fig. 4.2 depicts the result of component selection and the identification of connection flows, using the grammar of the energy diagramming in emergy theory. Compartments within the analysis window are employed to define the building and its environmental functioning, and, by associating them with external resource stocks and heat sinks, this system definition enables us to explore the energetic dynamics of the building as an ecosystem. Fig. 4.2 (a) presents the networking of forward emergy loops in which emergy generally circulates to increase system organization, i.e., emergy/material concentration or “order.” External nonrenewable resources are divided into five major compartments which represent major environmental sources for building construction, operation, and maintenance: natural gas, electricity, water, raw building material, and goods and services ($I_{NR1} \sim I_{NR5}$). Downstream impact from gas emission and/or waste discharge is also taken into account for the information change by supposing three export compartments ($E_1 \sim E_3$). It is important to assume that external sources/sinks are independent to each other, because their interactions, if any, are beyond our concern. Meanwhile, the building transfers internal resources to

other systems beyond our analysis window, which is a generation of useful nutrients for the global environment. Material recycling, for example, is a very effective and natural systemic technique to strengthen the development of the building itself and geobiosphere. It is a kind of feedback action, but should not be represented within the analysis window, since the final destination of the feedback pathway is beyond our observation. So, external feedbacks are added to the export paths.

Table 4.2 Categorization and description of network flows of the whole building system

Flow	Description	Flow	Description
Forward flows			
$f_{R,1}$	Solar radiation onto a building site	$f_{5,8}$	Energy gain from hot water shower/food
$f_{R,2}$	Renewable source inputs to landscape	$f_{5,E3}$	Recycling of clothing, appliances, or furniture
$f_{R,3}$	Solar/wind energy onto a building envelope	$f_{6,7}$	Internal heat gain from lighting devices
$f_{R,4}$	Renewable inputs to mechanical equipment	$f_{7,3}$	Heat transfer to an envelope (conduction/ventilation)
$f_{2,4}$	Energy transfer from landscape to HVAC system	$f_{7,4}$	Heat pump source flow in winter
$f_{3,1}$	Heat loss to ambient environment	$f_{8,2}$	Human labor for landscape maintenance
$f_{3,4}$	Energy generated within the envelope and structure	$f_{8,5}$	Human labor (indoor)
$f_{3,6}$	Natural light/ Sunlight penetrating an envelope to a lighting device (e.g., light shelf/duct)	$f_{8,7}$	Internal heat gain from human bodies
$f_{3,7}$	Heat conduction from walls/Direct radiation through windows and perforations/Heat recovery	$f_{8,E3}$	Upcycling export of useful energy (e.g., material export for recycling, work activities, etc.)
$f_{4,1}$	Heat discharge from cooling systems	$f_{NR,2}$	Material, water, goods and services for landscape
$f_{4,2}$	Grey/rain water reuse for landscape irrigation	$f_{NR,3}$	Raw material, goods, and services for building manufacturing and maintenance
$f_{4,5}$	Hot water /Utility for cooking and home appliances	$f_{NR,4}$	Gas, electricity, water, material, goods, and services for mechanical system manufacturing and operation
$f_{4,6}$	Electricity for lighting fixtures and luminaires	$f_{NR,5}$	Raw material, goods, and services for interior space construction, appliances, and furniture. (e.g., food supplies, financial income, etc.)
$f_{4,7}$	Energy use for space heating	$f_{NR,6}$	Purchase of luminaires or other lighting devices
$f_{4,E3}$	Export of electricity to grid	$f_{NR,8}$	Purchase of clothes, food, and accessories
$f_{5,7}$	Internal heat gain from electric/gas equipment		
Potential regeneration flows			
$f_{4,R}$	Heat transfer from HVAC system to ground (e.g., GSHP)	$f_{5,4}$	Restoration of grey water/ Heat pump source in summer
ETC.			
s_{1-8}	Heat sink/Depreciation of material and information	a_{1-8}	Potential export of solid waste or water
b_{1-8}	Potential export of discharging gas	$f_{2-6,E}$	Export of material, useful energy, and information

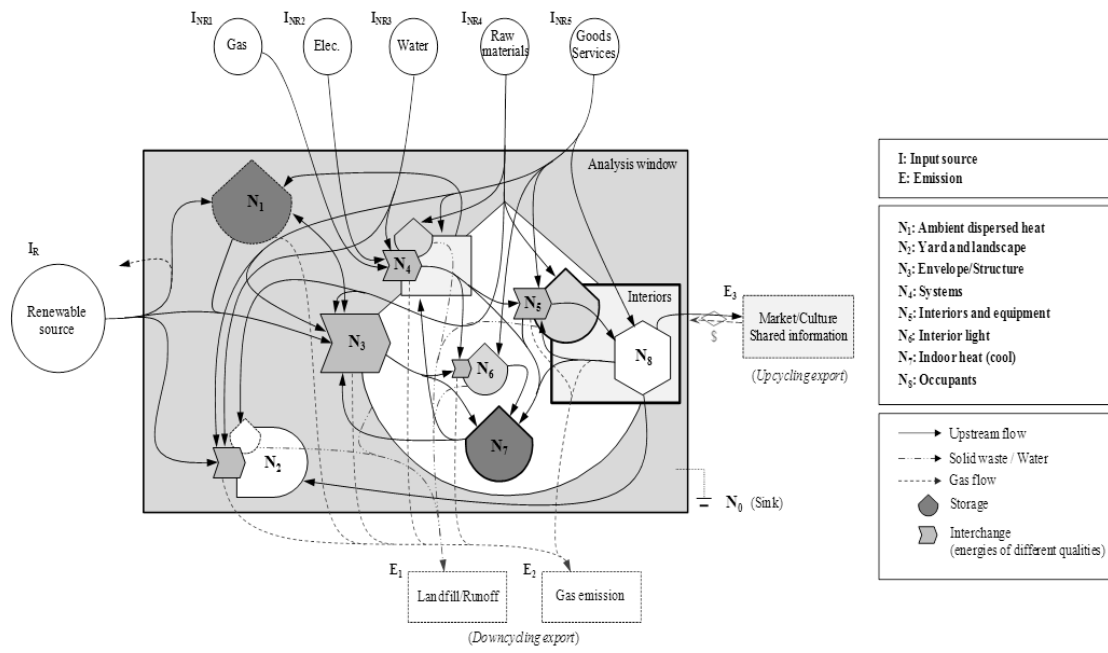

(a) Forward loops

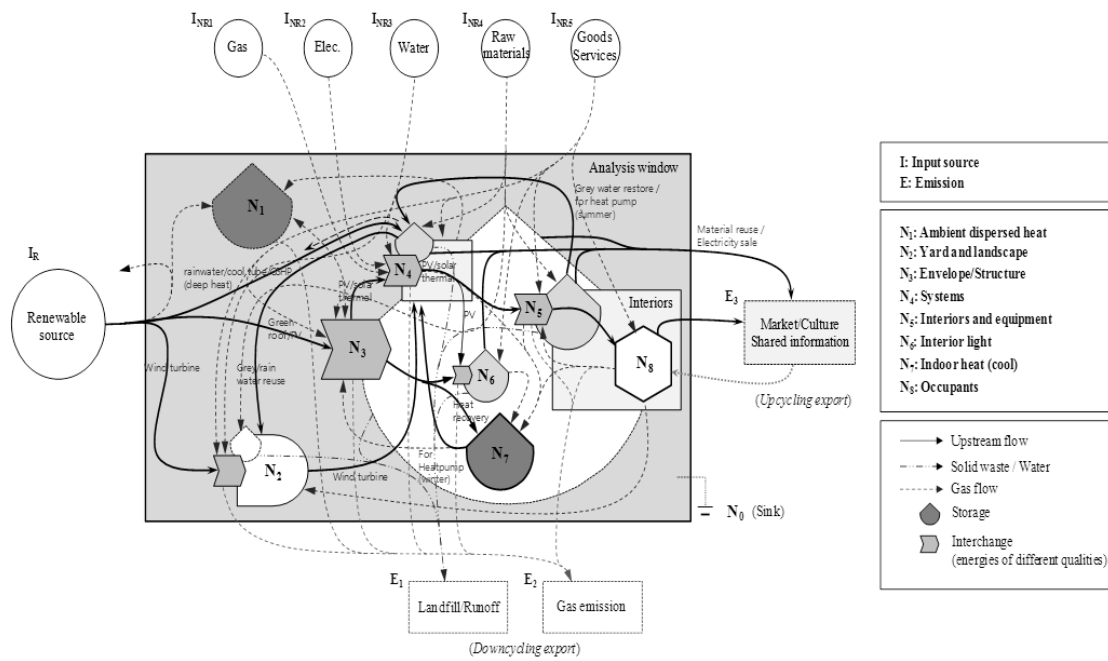

(b) Forward and backward loops

Fig. 4.2 Diagrams of the whole building system network model (with component symbols from energy theory)

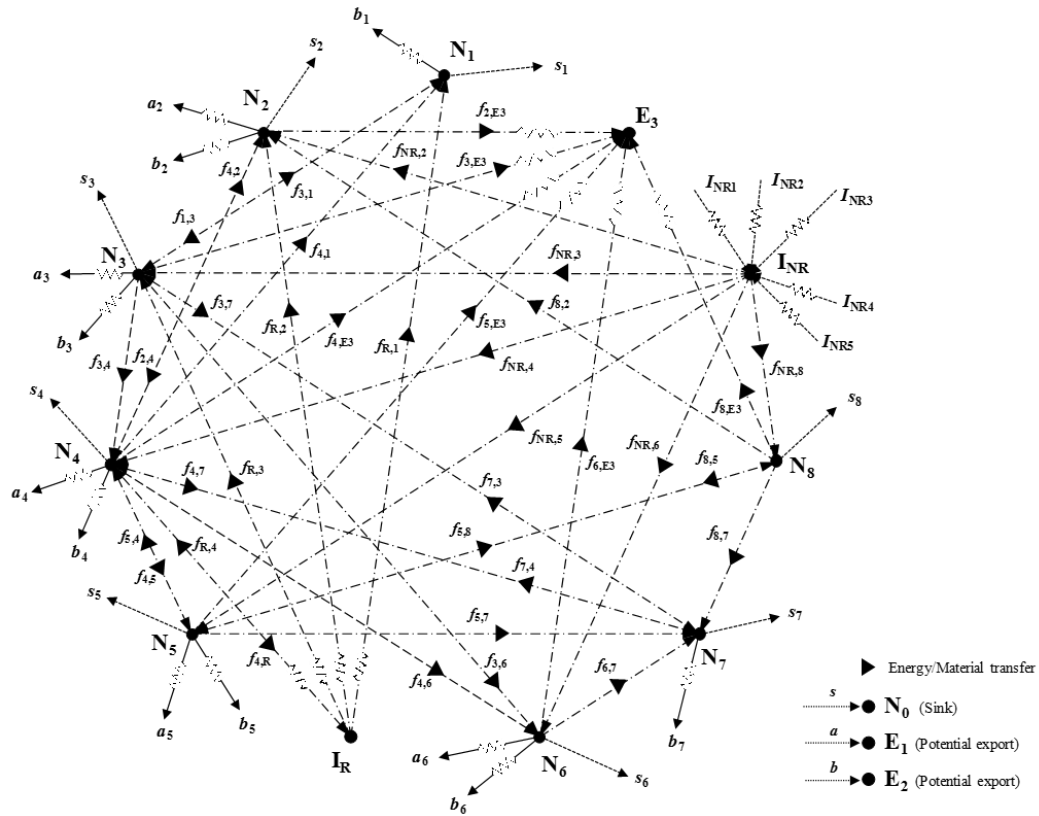

(a) Compartmental system networking model (Nonrenewable sources ($I_{NR1\sim5}$) look lumped in this illustration, but they are calculated respectively)

0	0	0	0	0	0	0	0	0	0	0	0	0	0	0	0	0	0	
0	0	0	0	0	0	0	$f_{R,1}$	$f_{R,2}$	$f_{R,3}$	$f_{R,4}$	0	0	0	0	0	0	0	
0	0	0	0	0	0	0	0	0	0	$f_{NR1,4}$	0	0	0	0	0	0	0	
0	0	0	0	0	0	0	0	0	0	$f_{NR2,4}$	0	0	0	0	0	0	0	
0	0	0	0	0	0	0	0	$f_{NR3,2}$	0	$f_{NR3,4}$	0	0	0	0	0	0	0	
0	0	0	0	0	0	0	0	$f_{NR4,2}$	$f_{NR4,3}$	$f_{NR4,4}$	$f_{NR4,5}$	$f_{NR4,6}$	0	0	0	0	0	
0	0	0	0	0	0	0	0	$f_{NR5,2}$	$f_{NR5,3}$	$f_{NR5,4}$	$f_{NR5,5}$	$f_{NR5,6}$	0	$f_{NR5,8}$	0	0	0	
s_1	0	0	0	0	0	0	0	0	$f_{1,3}$	0	0	0	0	0	0	b_1	0	
s_2	0	0	0	0	0	0	0	0	0	$f_{2,4}$	0	0	0	0	a_2	b_2	$f_{2,E3}$	
s_3	0	0	0	0	0	0	0	$f_{3,1}$	0	0	$f_{3,4}$	0	$f_{3,6}$	$f_{3,7}$	0	a_3	b_3	$f_{3,E3}$
s_4	$f_{4,R}$	0	0	0	0	0	0	$f_{4,1}$	$f_{4,2}$	0	0	$f_{4,5}$	$f_{4,6}$	$f_{4,7}$	0	a_4	b_4	$f_{4,E3}$
s_5	0	0	0	0	0	0	0	0	0	0	$f_{5,4}$	0	0	$f_{5,7}$	$f_{5,8}$	a_5	b_5	$f_{5,E3}$
s_6	0	0	0	0	0	0	0	0	0	0	0	0	0	$f_{6,7}$	0	a_6	b_6	$f_{6,E3}$
s_7	0	0	0	0	0	0	0	0	$f_{7,3}$	$f_{7,4}$	0	0	0	0	0	0	b_7	0
s_8	0	0	0	0	0	0	0	0	0	0	$f_{8,2}$	0	0	$f_{8,5}$	0	$f_{8,7}$	0	$f_{8,E3}$
0	0	0	0	0	0	0	0	0	0	0	0	0	0	0	0	0	0	0
0	0	0	0	0	0	0	0	0	0	0	0	0	0	0	0	0	0	0
0	0	0	0	0	0	0	0	0	0	0	0	0	0	0	0	0	0	0

(b) Conversion into a matrix

Fig. 4.3 Digraph representation of the whole building system network model

Fig. 4.3 shows a conversion of the emergy diagram to a nodal network, which enables the integration of the system configuration and computational procedure. It should be noted that equivalency of emergy quantity between inputs and outputs at a node is not a necessary constraint, for emergy can be cumulated in the component.

4.2.3 Network model integrating the metabolism of the building envelope

Exploring thermodynamic networking of the building envelope is important for examining information content and the resilience of the building form, because the shape of a building enclosure is immediately coupled with the building form and architectural style. By doing so, we can eventually identify the environmental performance of the form and style. The building envelope system consists of fewer components in comparison to the whole building, even though more complex and dynamic thermal exchanges are under our scrutiny. Fig 4.4 presents an emergy system diagram that accounts for envelope-related thermodynamic actions. It is basically developed from the whole system diagram (Fig. 4.2), but more sophisticated in that it subdivides the building envelope component (energy gate) into physical elements (ground floor, roof, and walls). The focus of investigation is on how a formal organization of the elements (design) ensuring thermal comfort generates information by managing heat/light flows between the inside and outside. To reduce influence from the external source variation, nonrenewable sources are aggregated into a single compartment. By the same token, the occupant's interventions transform the building form. The network configuration includes extraneous source flows to the human activities and mechanical conditioning equipment.

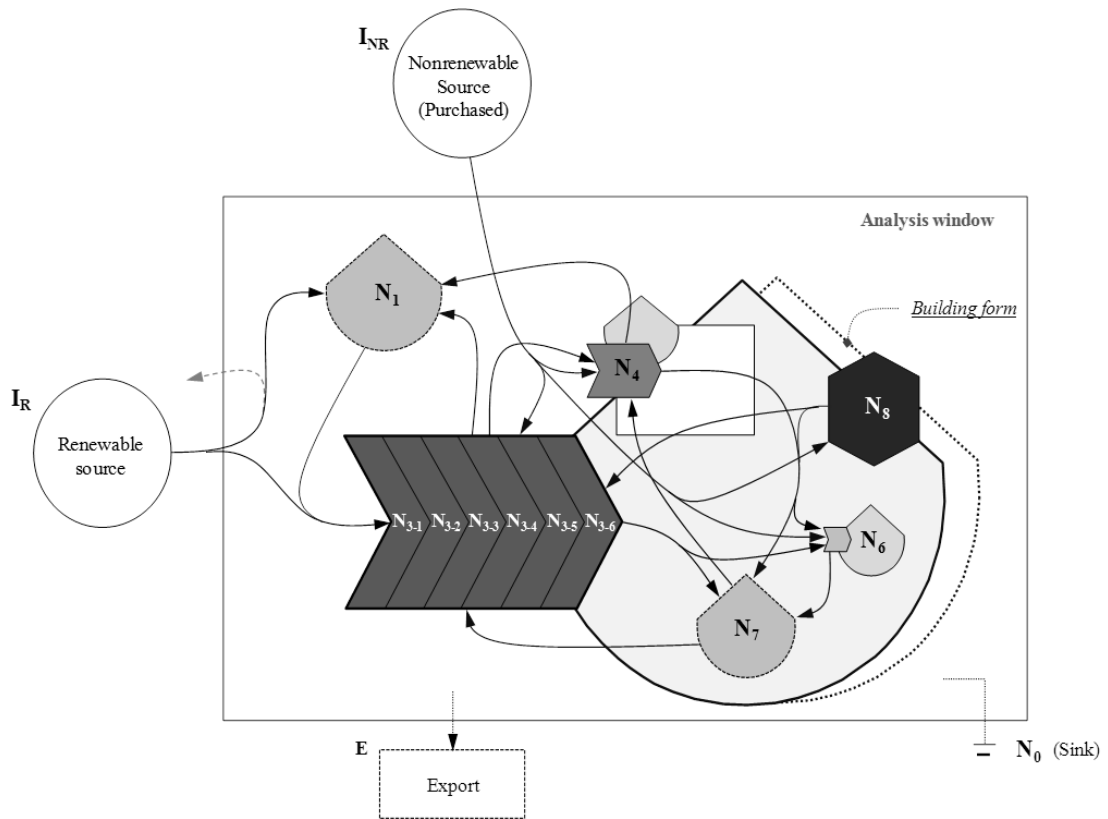

Fig. 4.4 Diagram of the building envelope system network model (with component symbols from energy theory)

Table 4.3 lists energy flows across the envelope components. Renewable/nonrenewable sources (I_R and I_{NR}) flow in each envelope element ($N_{3.1} \sim N_{3.6}$), and heat gain/loss ($f_{1,3-1 \sim 6} / f_{3-1 \sim 6,1}$) from/to the ambient thermal storage (N_1) shows the envelope takes in charge of the control of environmental perturbation. It is noteworthy that the conditioning system (N_4), light (N_6), indoor thermal storage (N_7), and occupants (N_8) are employed to define the building form. It is because (1) they are spatially enclosed by the enclosure in whole or in part, and (2) energetic interactions of those indoor components end up making a specialized form of the envelope. Thus, the building form embodies information content through the thermodynamic networking. Meanwhile, the occupant component (N_8) is an internal source of genetic (human) information. Every human behavior within building spaces entails decision-making as well as an energy transfer, and that gives rise to the changes in building information content. Even if an amount of physiological energy transmission to the building form is negligible, the implication of the human action is significant, due to its very high transformity, in the information of the system.

For computational convenience, the above energy diagram is converted to a diagram and matrix (Fig. 4.5). Each node other than external sources and the occupant has connections to both a heat sink (s) and export nodes (e). Export energy flows become important if the building produces useful energy (electricity generation from solar panels).

Table 4.3 Categorization of forward flows in the building envelope network

Flow	Description
$f_{R,1}$	Solar radiation on a building site
$f_{R,3-1-6}$	Import of renewable energy (solar/wind/rain) to each part of a building envelope (e.g., roof vegetation, heat conduction, ventilation, solar radiation, etc.)
$f_{N,3-1-6}$	Import of purchased nonrenewable energy (electricity/natural gas/building material/service) to each part of a building envelope
$f_{NR,4}$	Import of purchased nonrenewable energy to a HVAC system
$f_{NR,6}$	Raw materials and services for lighting fixtures and luminaires
$f_{NR,8}$	Purchase of clothes, food, and accessories
$f_{1,3-1-6}$	Heat flow from ambient environment to each part of a building envelope
$f_{3-1-6,1}$	Heat flow from each part of a building envelope to ambient environment
$f_{3-1-6,4}$	Energy flow from part of an envelope to a HVAC system
$f_{3-1-6,6}$	Natural light through glazing or perforation of an envelope
$f_{3-1-6,7}$	Indoor heat gain from each part of an envelope
$f_{4,1}$	Heat discharge of a HVAC system for space cooling
$f_{4,6}$	Electricity use for lighting
$f_{4,7}$	Energy use for heat gain (during heating season)
$f_{6,7}$	Internal heat gain from lighting equipment
$f_{7,3-1-6}$	Indoor heat loss to each part of an envelope
$f_{7,4}$	Indoor energy transfer for heat discharge (during cooling season)
$f_{8,3-1-6}$	Occupant behavior (energy and information delivery to each part of an envelope)
$f_{8,4}$	Occupant behavior (energy and information delivery to a HVAC system and a light controller)
$f_{8,7}$	Heat released from human bodies
s	Heat drain, depreciation of material and information
e	Export of useful energy

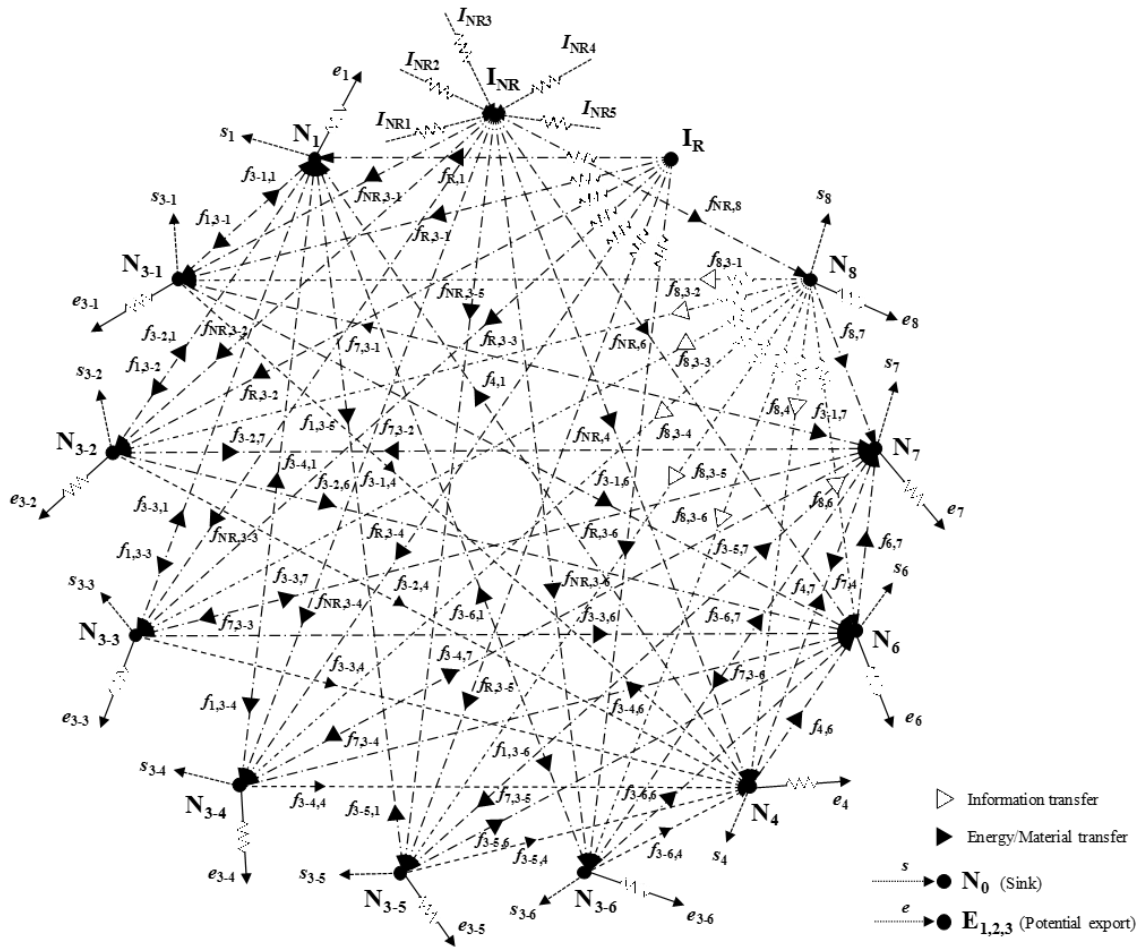

(a) Compartmental system networking

0	0	0	0	0	0	0	0	0	0	0	0	0	0	0
0	0	0	$f_{R,1}$	$f_{R,3-1}$	$f_{R,3-2}$	$f_{R,3-3}$	$f_{R,3-4}$	$f_{R,3-5}$	$f_{R,3-6}$	0	0	0	0	0
0	0	0	0	$f_{NR,3-1}$	$f_{NR,3-2}$	$f_{NR,3-3}$	$f_{NR,3-4}$	$f_{NR,3-5}$	$f_{NR,3-6}$	$f_{N,4}$	$f_{N,6}$	0	0	0
s_1	0	0	0	$f_{1,3-1}$	$f_{1,3-2}$	$f_{1,3-3}$	$f_{1,3-4}$	$f_{1,3-5}$	$f_{1,3-6}$	0	0	0	0	$f_{1,E}$
s_{3-1}	0	0	$f_{3-1,1}$	0	0	0	0	0	0	$f_{3-1,4}$	$f_{3-1,6}$	$f_{3-1,7}$	0	$f_{3-1,E}$
s_{3-2}	0	0	$f_{3-2,1}$	0	0	0	0	0	0	$f_{3-2,4}$	$f_{3-2,6}$	$f_{3-2,7}$	0	$f_{3-2,E}$
s_{3-3}	0	0	$f_{3-3,1}$	0	0	0	0	0	0	$f_{3-3,4}$	$f_{3-3,6}$	$f_{3-3,7}$	0	$f_{3-3,E}$
s_{3-4}	0	0	$f_{3-4,1}$	0	0	0	0	0	0	$f_{3-4,4}$	$f_{3-4,6}$	$f_{3-4,7}$	0	$f_{3-4,E}$
s_{3-5}	0	0	$f_{3-5,1}$	0	0	0	0	0	0	$f_{3-5,4}$	$f_{3-5,6}$	$f_{3-5,7}$	0	$f_{3-5,E}$
s_{3-6}	0	0	$f_{3-6,1}$	0	0	0	0	0	0	$f_{3-6,4}$	$f_{3-6,6}$	$f_{3-6,7}$	0	$f_{3-6,E}$
s_4	0	0	0	0	0	0	0	0	0	0	0	$f_{4,6}$	$f_{4,7}$	0
s_6	0	0	0	0	0	0	0	0	0	0	0	0	$f_{6,7}$	0
s_7	0	0	0	$f_{7,3-1}$	$f_{7,3-2}$	$f_{7,3-3}$	$f_{7,3-4}$	$f_{7,3-5}$	$f_{7,3-6}$	0	0	0	0	$f_{7,E}$
s_8	0	0	0	$f_{8,3-1}$	$f_{8,3-2}$	$f_{8,3-3}$	$f_{8,3-4}$	$f_{8,3-5}$	$f_{8,3-6}$	$f_{8,4}$	$f_{8,6}$	$f_{8,7}$	0	$f_{8,E}$
0	0	0	0	0	0	0	0	0	0	0	0	0	0	0

(b) Conversion into a matrix

Fig. 4.5 Digraph representation of the envelope system network model

4.3 Energy-information integrated formulation

4.3.1 Advantages of the emergy metric system to the measurement of complexity

As discussed in Chapter 2, emergy measures environmental impacts at the global system level in a unified and quantitative metric. Specifically, introducing an emergy unit to the building network analysis has two integral advantages: (1) identification of the direct implications of local variations (in building components) to the global environment and (2) greater sensitivity in the indication of performance than non-system-based metrics (energy, exergy, etc.). Any metric that can describe a network pattern of system behavior is generally available for measuring flow quanta. Ulanowicz (1986) uses energy for ecosystem modeling, and Kharrazi et al. (2013) uses a monetary unit for oil-trade analyses. However, analyses of the system may only represent a very limited temporal/spatial situation.

Unless we recognize the ultimate source of energy, and the energy dissipation is considered for each network flux. It leads to a misunderstanding of the hierarchical structure of the building components.

In this regard, emergy makes visible the full qualitative and quantitative range of natural and human work and social services delivered to a quantum of building thermodynamic flows as well as their qualities with solar transformities (sej/unit).

Moreover, emergy more effectively quantifies the change of network pattern particularly in the upper level ecosystem such as the built environment. Christensen (1994) demonstrates that emergy is more sensitive than energy to the change of organization at high trophic levels, because the amount of energy circulation considerably diminishes as the trophic level increases. The socio-technological systems that the building network analyses deal with are generally positioned in the highest level within the global environmental system. Therefore, information measured with an emergy unit is most suitable to examine the variation of environmental resource flows impacted simultaneously by nature, design (shared information), and the context of socio-technological infrastructure.

4.3.2 Computation algorithm for life cycle analysis

An overarching characteristic of this network-based methodology is that it is

capable of integrating the donor-side (upstream) energy delivery and the impact from end-users (downstream) on a lifecycle basis. To suggest formulas of computational algorithm, we consider the equations of life cycle energy analysis (LCEA) and life cycle impact analysis (LCIA). The total useful energy invested in a building during its life (Q_E) is represented by extending the LCEA formula (Bekker, 1982; Adalberth, 1997) to include all building related services such that:

$$\begin{aligned}
 Q_E &= Q_M + Q_C + Q_O + Q_R + Q_D \\
 &= (Q_{MP} + Q'_{MP}) + (Q_{CT} + Q_{CS} + Q'_{CT} + Q'_{CS}) + (Q_{OC} + Q_{OS} + Q_{OE}) + (Q_{DT} + Q_{DS}) \quad (4.1)
 \end{aligned}$$

where Q_E : total useful energy invested for building during its life

Q_M : energy for material production

Q_C : energy for building construction

Q_O : energy for building operation

Q_D : energy for demolition and recycling

Q_R : energy for renovation and maintenance ($Q_R = Q'_{MP} + Q'_{CT} + Q'_{CS}$)

Q_{MP} : energy for materials of initial manufacturing

Q'_{MP} : energy for materials of maintenance

Q_{CT} : energy for transport in construction

Q_{CS} : energy for services in construction

Q'_{CT} : energy for transport in recurring construction

Q_{OS} : operational energy for services

Q'_{CS} : energy for services in recurring construction

Q_{OC} : operational energy for indoor conditioning

Q_{OE} : operational energy for electric equipment and lighting

Q_{DT} : energy for transport in building demolition, reuse, and recycling

Q_{DS} : energy for services in building demolition, reuse, and recycling

Q_{CS} accounts for human work and indirect energy investment (i.e., use of machinery), and Q_{OS} includes water use, food, electronics, and other supplies for building occupants. From Eq. (4)-1, the total energy for the building life (Em_T) is computed by multiplying it by the transformity (Tr) of each term:

$$\begin{aligned}
 Em_T &= Tr_N Q_N + Tr_E Q_E = Tr_N Q_N + Tr_M Q_M + Tr_C Q_C + Tr_O Q_O + Tr_R Q_R + \\
 &Tr_D Q_D \quad (4.2)
 \end{aligned}$$

where Q_N is energy invested within a site boundary from natural/renewable sources

Notice that energy invested within a site boundary from natural/renewable sources (Q_N ; e.g. solar radiation, soil, and other renewable sources such as rain and wind) on building surface and landscape must be included the emergy estimate. On the other hand, BEmA does not fully consider the downstream impact of building energy use and other operational activities. The building's environmental impact is identified from three primary sources: (i) solid waste that goes to landfills, (ii) emission to the air, and (iii) emission to the water. Solid waste can be recycled or reused with refurbishment, but harmful discharge may happen during reprocessing. To evaluate the emergy value of pollutants, Reza et al. (2014) introduce a new emergy-based indicator to recover losses of geobiological environmental capacity. In other words, the emergy of waste in landfill is estimated by potential emergy for the land restoration such that:

$$Em_{LL} = \left(\sum_i s_i \cdot Loc_i \right) Em_L \quad (4.3)$$

where Em_{LL} is emergy impact of landfill (sej), s_i is weight of solid waste of an i th material (kg), Loc denotes land occupation factor of the waste (ha/kg), and Em_L is emergy of land restoration per a unit area (sej/ha). Similarly, emergy losses due to the loss of natural sources (Em_{LN}) and human health (Em_{LH}) are given by:

$$Em_{LN} = \left(\sum_i c_i \cdot DF_i \cdot AY_i \right) Em_B \quad (4.4)$$

$$Em_{LH} = \left(\sum_i c_i \cdot DY_i \right) Em_P \quad (4.5)$$

where c_i is the amount of harmful chemical released to the air and the water (kg), DF refers to potentially disappeared fraction of species per a unit weight in the influenced ecosystems (%/kg), AY is a dimension of the affected ecosystem area and time (m^2 yr), and Em_B denotes an annual emergy budget allocated to the regional natural capital (sej/ m^2 yr). In Eq 4.5, DY means disability adjusted human life expectancy per unit emission (yr/kg), and Em_p is total annual emergy per population (1.73×10^{17} sej/yr/person).

Emergy coefficients used in the equations are estimated from previous studies. We

assign the energy values onto upstream network flows (Fig. 4.3 and Fig. 4.5) within a specific time frame. Note that the developed network models are to represent dynamic variations of the magnitude of energy. Introducing the time dimension with a new temporal variable t , where t denotes elapse time (year, month, or hour) after building completion, the following equation can be established:

$$F'_p(t) = Tr_N(t)Q_N(t) + Tr_M(t)Q_M(t) + Tr_C(t)Q_C(t) + Tr_R(t)Q_R(t) \quad (4.6)$$

where $F'_p(t)$ is total energy flow (for building manufacturing and maintenance at time t (yr), $F'_p(t) = \sum_{i=2}^4 f_{R,i} + \sum_{j=3}^5 \sum_{k=2}^6 f_{NR,j,k}$ for the whole building system, or $F'_p(t) = f_{R,3} + \sum_{i=3}^4 f_{NR,i} + f_{NR,6}$ for the building envelope.

For this study, we assume that transformities are static, and natural sources and energy for building erection are evenly distributed over a period in which the energy is invested. Introducing a life span of a whole building (l_T) and each component ($l_{r,i}$) to Eq. (4.2), $F'_p(t)$ can be rewritten as:

$$\begin{aligned} F'_p(t) &= Tr_M(Q_{MP}(t) + Q'_{MP}(t)) + \frac{Tr_T(Q_{CT} + Q'_{CT}) + Tr_S(Q_{CS} + Q'_{CS})}{T_{C,tot}} + \frac{Tr_N Q_N}{l_T} \\ &= r_d(1 - r_d)^{t - \lfloor \frac{t}{l_r} \rfloor l_r} (Q_{MP} + Q'_{MP}) Tr_M + \frac{Tr_T Q_{CT} + Tr_S Q_{CS}}{T_C} \\ &\quad + \frac{Tr_T Q'_{CT} + Tr_S Q'_{CS}}{T'_C} + \frac{Tr_N Q_N}{l_T} \\ &= \sum_i r_{d,i} (1 - r_{d,i})^{t - \lfloor \frac{t}{l_{r,i}} \rfloor l_{r,i}} m_i \left(1 + \frac{w_i}{100}\right) Tr_{M,i} \left(1 - \frac{r_{uc,i}}{100}\right) \\ &\quad + \frac{Tr_T Q_{CT} + Tr_S Q_{CS}}{T_C} g(t) \\ &\quad + \sum_i \frac{Tr_{T,i} Q'_{CT,i} + Tr_{S,i} Q'_{CS,i}}{T'_{C,i}} h(t) + \frac{Tr_N Q_N}{l_T} \quad (4.7) \end{aligned}$$

where r_d : rate of depreciation of a building material or assembly

$$r_{d,i} = 1 - \sqrt[n]{\frac{\text{residual value of material } i}{\text{initial value of material } i}} \quad (n: \text{life span of } i\text{th material (yr)})$$

- $T_{C,tot}$: total construction time (yr)
- T_C : duration (yr) of initial construction phase T'_C : duration of recurring construction phase
- $g(t)$: 1 (if $1 \leq t \leq T_C$) or 0 (else)
- $h(t)$: 1 (if $kl_{r,i} \leq t \leq kl_{r,i} + T'_C, k=1, 2, 3, \dots$) or 0 (else)
- m : weight of a building material or assembly used for manufacturing (kg),
 $m = \rho V$ (ρ : unit weight, kg/m³; V : volume, m³)
- w : fraction of waste in a raw building material or assembly during construction (%)
- r_{uc} : reused or recycled fraction of a building material or assembly (%)
($t = 0, 1, 2, \dots, l_T - 1$)

On the other hand, total energy flows during building operation phases ($F'_C(t)$) and demolition ($F'_D(t)$) are respectively given by,

$$F'_C(t) = Tr_{OC} \dot{Q}_{OC} + Tr_{OE} \dot{Q}_{OE} + Tr_{OS} \dot{Q}_{OS} / l_T \quad (4.8)$$

$$F'_D(t) = \frac{t}{l_T(Q_{DT} + Q_{DS})Tr_D} \quad (4.9)$$

Therefore, total energy system throughput (TST) of the whole building system, including downstream flows, at time t is,

$$TST'(t) = F'_P(t) + F'_C(t) + F'_D(t) + F'_R(t) + \sum_i a'_i + \sum_j b'_j \quad (4.10)$$

where $TST'(t)$: Total energy system throughput (sej) of the whole building system at time t

$F'_R(t)$: Energy flows of regeneration (feedback flows)

$$\sum_{i=1}^7 a'_i + \sum_{j=1}^7 b'_j = Em_{LL}(t) + Em_{LN}(t) + Em_{LH}(t)$$

a'_i : Energy outflow from N_i to E1 (Landfill/runoff)

b'_j : Energy outflow from N_i to E2 (Emission)

Identifying each flow (f_{ij}) on the system circuit (Table 4.2 and 4.3) and associating it with the general analytical frame of LCEA are combinatorily vast and rely on a large number of datasets. Nevertheless, we can identify the following relationships:

4.3.2.1 Governing equations of the whole building system analysis

$$\left\{ \begin{array}{l} \text{Tr}_N \dot{Q}_N = \sum_{j=1}^4 f'_{R,j} + f'_{4,R} \\ \text{Tr}_M(Q_{MP}(t) + Q'_{MP}(t)) + \frac{\text{Tr}_T(Q_{CT} + Q'_{CT})}{T_{C,tot}} = \sum_{j=2}^4 f'_{N4,j}(t) \\ \text{Tr}_S Q_{CS}(t), \text{Tr}_S Q'_{CS}(t) = \sum_{j=2}^4 f'_{N5,j}(t) \\ \text{Tr}_{OC} \dot{Q}_{OC} + \text{Tr}_{OE} \dot{Q}_{OE} + \text{Tr}_{OS} \dot{Q}_{OS} = \sum_{i=N1}^{N5} \sum_{j=4}^5 f'_{i,j} \\ \text{Tr}_D(Q_{DT} + Q_{DS}) = \sum_{i=2}^6 \sum_{j=E1}^{E3} f'_{i,j} \\ \text{Em}_{LL}(t) = \sum_{i=2}^6 f'_{i,E1}(t) \\ \text{Em}_{LL}(t) + \text{Em}_{LH}(t) + \text{Em}_{LN}(t) = \sum_{i=2}^6 f'_{i,E1}(t) + \sum_{i=2}^6 f'_{i,E2}(t) + f'_{8,E2}(t) \end{array} \right.$$

Considering external supply and discharge (s_{ij} , a_{ij} , and b_{ij}), complexity, AMI, and resilience of the whole building network (unit: bits) are computed by:

$$\begin{aligned} H_B(t) &= \sum_{j=0}^8 \frac{f_{Rj}(t)}{T'(t)} \log \frac{f_{Rj}(t)}{T'(t)} + \sum_{i=N1}^{N5} \sum_{j=0}^8 \frac{f_{ij}(t)}{T'(t)} \log \frac{f_{ij}(t)}{T'(t)} + \sum_{i=1}^8 \sum_{j=1}^8 \frac{f_{ij}(t)}{T'(t)} \log \frac{f_{ij}(t)}{T'(t)} \\ &+ \sum_{i=1}^8 \sum_{j=E1}^{E3} \frac{f_{ij}(t)}{T'(t)} \log \frac{f_{ij}(t)}{T'(t)} \end{aligned} \quad (4.11)$$

$$\begin{aligned}
AMI_B(t) = & \sum_{j=0}^8 \frac{f_{Rj}(t)}{T'(t)} \log \frac{f_{Rj}(t)T'(t)}{T'_{R}(t)T'_{j}(t)} + \sum_{i=N1}^{N5} \sum_{j=0}^8 \frac{f_{ij}(t)}{T'(t)} \log \frac{f_{ij}(t)T'(t)}{T'_{i}(t)T'_{j}(t)} \\
& + \sum_{i=1}^8 \sum_{j=1}^8 \frac{f_{ij}(t)}{T'(t)} \log \frac{f_{ij}(t)T'(t)}{T'_{i}(t)T'_{j}(t)} \\
& + \sum_{i=1}^8 \sum_{j=E1}^{E3} \frac{f_{ij}(t)}{T'(t)} \log \frac{f_{ij}(t)T'(t)}{T'_{i}(t)T'_{j}(t)} \quad (4.12)
\end{aligned}$$

$$L_B(t) = H_B(t) - AMI_B(t) \quad (4.13)$$

4.3.2.2 Governing equations of the building envelope analysis

$$\left\{ \begin{aligned}
& \text{Tr}_N \dot{Q}_N = f'_{R,1} + f'_{R,3} \\
& \text{Tr}_M(Q_{MP}(t) + Q'_{MP}(t)) + \frac{\text{Tr}_T(Q_{CT} + Q'_{CT})}{T_{C,tot}} + \text{Tr}_S Q_{CS}(t) + \text{Tr}_S Q'_{CS}(t) = f'_{N,3} + f'_{N,4} \\
& \text{Tr}_D(Q_{DT} + Q_{DS}) = \sum_{j=E1}^{E3} f'_{3,j} + \sum_{j=E1}^{E3} f'_{4,j} + \sum_{j=E1}^{E3} f'_{6,j} \\
& \text{Em}_{LL}(t) + \text{Em}_{LH}(t) + \text{Em}_{LN}(t) = \sum_{i=3}^4 \sum_{j=E1}^{E3} f'_{i,j}(t) + \sum_{j=E1}^{E3} f'_{6,j}(t)
\end{aligned} \right.$$

Considering external supply and discharge (s_{ij} , a_{ij} , and b_{ij}), complexity, AMI, and resilience of the building envelope network (unit: bits) are computed by:

$$\begin{aligned}
H_E(t) = & \sum_{j=0}^8 \left(\frac{f_{Rj}(t)}{T'(t)} \log \frac{f_{Rj}(t)}{T'(t)} + \frac{f_{Nj}(t)}{T'(t)} \log \frac{f_{Nj}(t)}{T'(t)} \right) + \sum_{i=1}^8 \sum_{j=1}^8 \frac{f_{ij}(t)}{T'(t)} \log \frac{f_{ij}(t)}{T'(t)} \\
& + \sum_{i=1}^8 \sum_{j=E1}^{E3} \frac{f_{ij}(t)}{T'(t)} \log \frac{f_{ij}(t)}{T'(t)} \quad (4.14)
\end{aligned}$$

$$\begin{aligned}
& \text{AMI}_E(t) \\
&= \sum_{j=0}^8 \left(\frac{f_{Rj}(t)}{T'(t)} \log \frac{f_{Rj}(t)T'(t)}{T'_{R}(t)T'_j(t)} + \frac{f_{Nj}(t)}{T'(t)} \log \frac{f_{Nj}(t)T'(t)}{T'_{N}(t)T'_j(t)} \right) \\
&+ \sum_{i=1}^8 \sum_{j=1}^8 \frac{f_{ij}(t)}{T'(t)} \log \frac{f_{ij}(t)T'(t)}{T'_i(t)T'_j(t)} \\
&+ \sum_{i=1}^8 \sum_{j=E1}^{E3} \frac{f_{ij}(t)}{T'(t)} \log \frac{f_{ij}(t)T'(t)}{T'_i(t)T'_j(t)} \tag{4.15}
\end{aligned}$$

$$L_E(t) = H_E(t) - \text{AMI}_E(t) \tag{4.16}$$

CHAPTER 5

APPLICATION AND VERIFICATION

To verify the behavior of the building as a self-organizing system, experiments are conducted to demonstrate that the final goal of a building's environmental functioning (performance) is to increase (maximize) empower and to adjust (optimize) system efficiency with energetic flows spontaneously organized, while an immediate goal might be reducing the quantity of non-renewable source import (energy, material, and services). In terms of energy flows, the concern is how building's thermodynamic information and informational performance indices behave according to the variation of the flow topology. Two case study buildings are selected for comparison, since even an identical design decision-making is expected to cause different consequences on the configuration of energy networking. Changes in information content are examined with an energy-information integrated calculation.

5.1 Overview of case study buildings and methods of experiment

This experimentation examines and analyzes building system information and ecosystem-level indices by identifying energy flow networking. Resolution of the exploration on the consequences of energy variation depends on a time period of system observation (Chapter 4 Fig. 4.1). Simulation-based information analyses are used to incorporate operational energy use, predicted material depreciation, and occupants' activities into the exploration of the reciprocal influence between the global and local ecosystem changes.

5.1.1 Description of the case study buildings and data collection

Table 5.1.1 Comparative description of test buildings

	Test building A (Baseline)	Test building B (Net zero energy house)
Site area	1265.99 m ²	1245.87 m ² ^a
Total floor area	340.73 m ²	315.69 m ² ^b
Conditioned floor area	282.38 m ²	254.34 m ²
Conditioned air volume	722.01 m ³	769.52 m ³
Exterior surface area ^c	460.31 m ²	192.30 m ²
Glazing area (skylight) ^d	35.11 m ²	68.12 m ²
Window-to-wall ratio ^d	11.30%	23.39%
Internal mass ^e	931.26 m ²	178.80 m ²
Heating/Cooling system	Gas furnace/DX air conditioner	Ground source heat pump (water)
Renewable energy system	No	Solar panel/Wind turbine
Automatic thermostat	No	Yes
Glazing	Double	Low-e triple/double
Structure	Wood frame	Steel frame

Note: ^a An ancillary building for public information (315.69m²) is in the same plot (2456.10 m²). Thus, the site area for building B only is obtained according to the floor area ratio. ^b Except underground mechanic room (84.85m²). ^c Including roofs, exposed floors, and exterior surfaces adjacent to sunroom covered with double-skin space. ^d Considering conditioned area (heat transfer zone) only. ^e If both side of an interior wall are exposed to a thermal zone, its surface area is double counted.

Table 5.1.1, Fig. 5.1.1, and Fig. 5.1.2 give an overview of case study buildings. Two existing single-family houses of similar sizes were chosen for comparative information analyses. Even though the locations are different, site area, total floor area, and conditioned volume are quite similar. Building A is a general house type constructed in 1960s in Pennsylvania, U.S., and Building B is located in a suburb of Seoul, South Korea. It was constructed in 2009 by SAMSUNG as the first LEED platinum-credited building in East Asia. This building is a one-storey 315.69m² Net zero energy building (NZEB) for residential use. So, in this study, Building A is used as a baseline in terms of energy use and system network design, while Building B is used as a proposed one. For both test buildings, building data about construction, operation, and maintenance have been collected in an intensive and extensive manner.

Field data and results of energy simulation using EnergyPlus are used for building energy analysis (BEmA). However, numeric calculations cannot help involving two inherent types of uncertainty, as it includes all the environmental resources invested to every building element and process: (1) quantities of input energies and materials; and (2) transformity or specific energy values. In order to minimize this uncertainty, Data quality and transparency plays an important role in assurance of computation results for this study. Elaborate efforts were made to collect the data as accurately as possible from field study, drawings, and energy inventories. The latest techniques were also utilized for the estimation of each network flow quantity.

The thermal comfort of Building A is provided by a conventional and popular type of system, gas furnace and electric direct expansion conditioner, whereas Building B adopts high-end technology, a ground-source heat pump. Design and construction of building B were by Ove Arup & Partners and SAMSUNG for the LEED certification. Accordingly, most data about mechanical equipment and energy simulation parameters were referenced from the technical documents that they submitted to the U.S. Green Building Council. In-house detail drawings and design documents were also examined to measure material quantities and system specifications. Building B is intended to achieve an “on-site” net-zero energy definition, and was based on the architectural style of Korean traditional houses, where renewable energy production meets operational energy demand within the site boundary of 1245.87 m². For climate adaptation, the front is exposed to the south, stretching from east to west. The main entrance, large openings, and windows are on the south façade, whereas much smaller windows are placed on the north. the building is lightweight steel-framed, and clad with hardwood, refurbished wood, zinc, and ceramic stone tiles. 73.3% of construction materials were acquired from the local area. Renewable energy is produced in electricity primarily from building (roof) integrated photovoltaic panels (BIPV), and solar thermal panels on the roof support domestic water heating. This building adopts a ground source heat pump (GSHP) system, and HVAC (heating, ventilation, and air-conditioning) and lighting systems are monitored with sensors to control their operations automatically.



(a) Front view

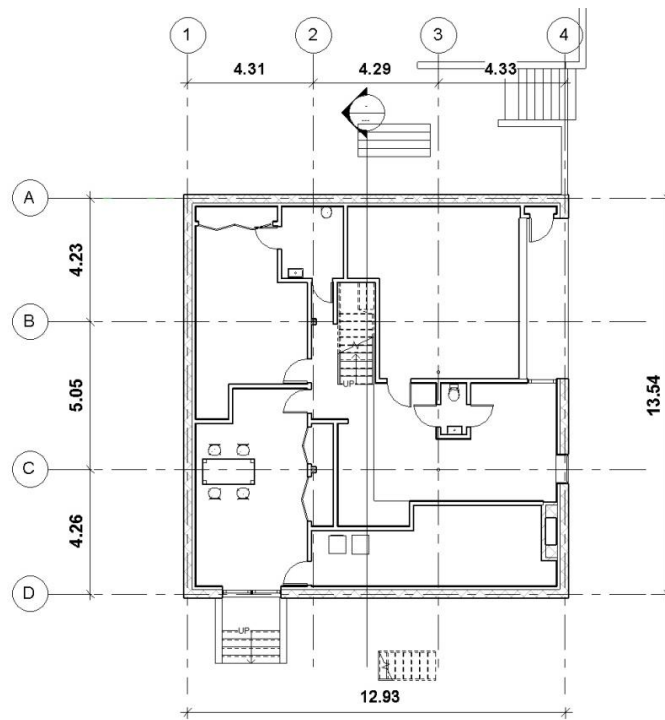

(b) Ground plan

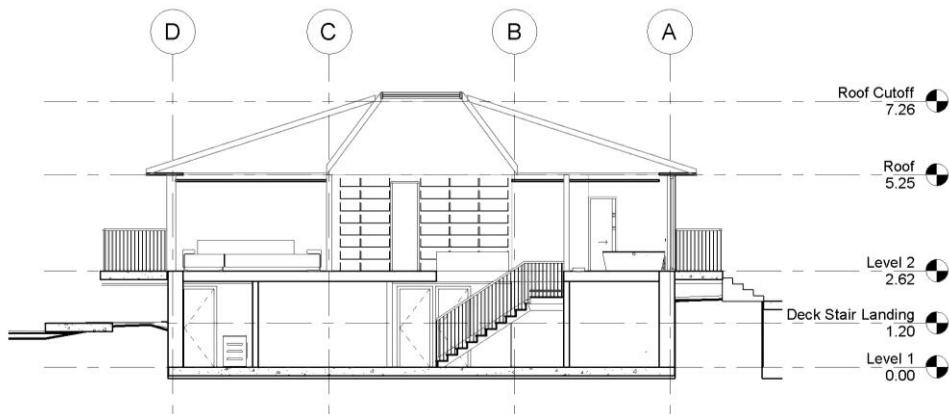

(c) Section

Fig. 5.1.1 Overview of test building A



(a) Front view

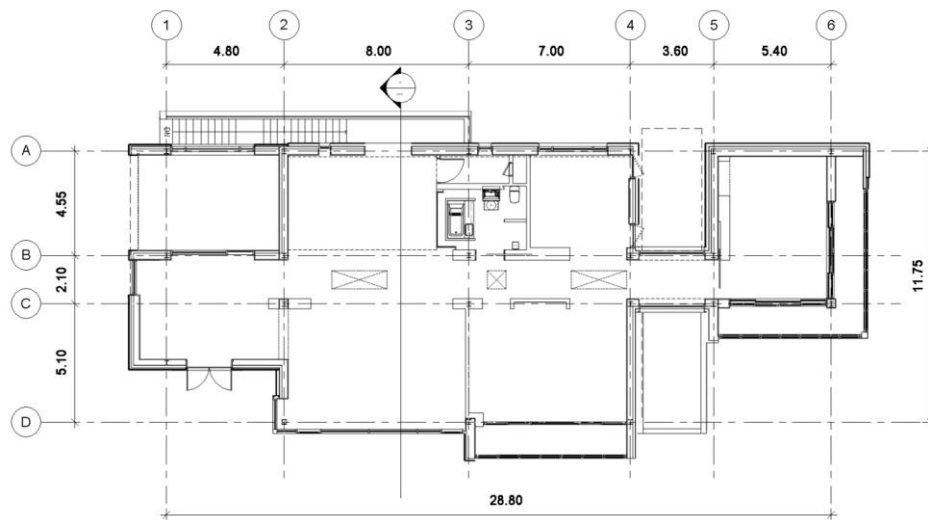

(b) Plan

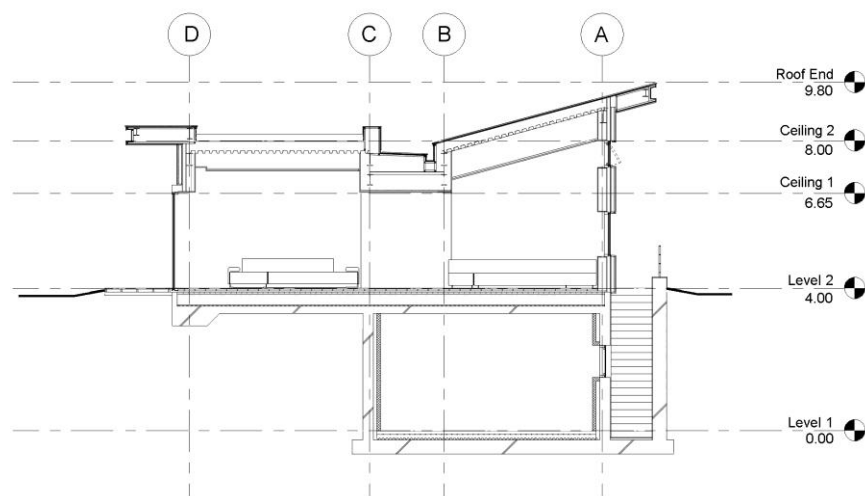

(c) Section

Fig. 5.1.2 Overview of test building B

5.1.2 Building energy simulation: modeling and results

Measurement of energy use is important in BEmA during operational phases. Even though meter data is available for the test buildings, whole building energy simulations were carried out for further scenario-based comparative analyses. High-quality input parameter values and modeling methods reduce uncertainty of simulation results. Energy standards and code for efficient design such as ASHRAE 90.1 thus provide energy simulation guidelines and protocols for various types of buildings, yet there has been no standardized reference for low-rise residential buildings. In this study, data and parameters from the Building America House Simulation Protocols (BAHSP; Wilson et al., 2014) were used to set up a baseline simulation model. While keeping the actual data of the specification of mechanical systems and internal mass, the operation schedules (light, occupancy, set points, etc.), electrical loads, and other inputs, which are unknown and indeterminable, were based on the BAHSP (Appendix H).

While strictly keeping the conditioned volume and surface area, the input building geometry for the main living areas was simplified to lump multiple functional spaces into a single thermal zone. Topological simplification of minor geometrical factors (e.g. roof angle) is quite acceptable for such small houses, and does not degrade the simulation quality within an allowable error range (EnergyPlus). By the same token, fenestration is also combined together so that each surface of a thermal zone has a single glazing area (Fig 5.1.3).

Building A is divided into three thermal zones. Conditioned areas are aggregated into a single thermal zone, while other two separate zones (garage and mechanic room) are considered unconditioned. Building B has a more complex shape and, thus, it is quite tricky to subdivide spaces into thermal zones. However, likewise, mechanical rooms and storage are set to be unconditioned. Balcony areas of the double-leaf façade are also treated as an unconditioned thermal zone, whereas the living area is fully conditioned.

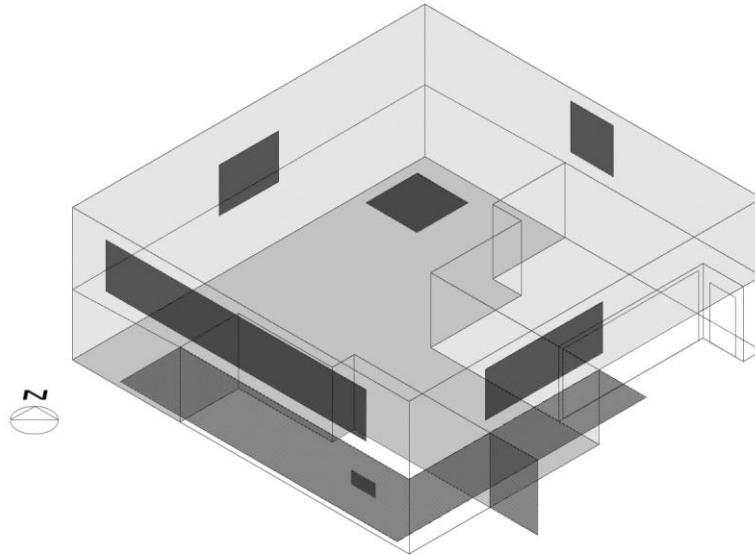

(a) Building A (Conditioned thermal zone- total volume: 718.69m^3 ; window area: 31.33m^2)

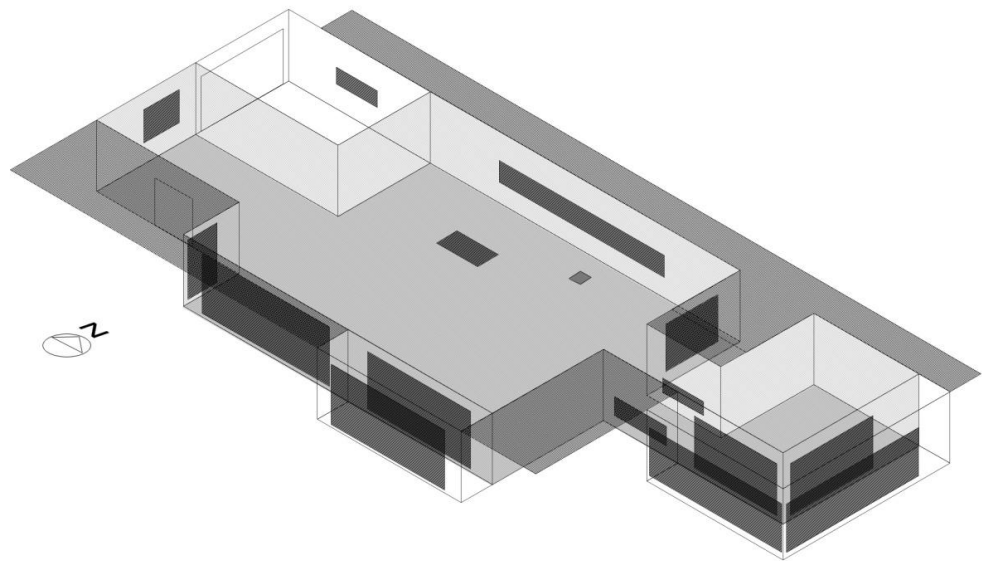

(b) Building B (Conditioned thermal zone- total volume: 763.02m^3 ; window area: 68.12m^2)

Fig. 5.1.3 Representation of EnergyPlus input geometry

Simulation results were compared to both meter data and the benchmark model proposed by BAHSP (BA house) to ensure reliability of the tests. As shown in Fig. 5.1.4 (a), recent actual data (as of 2012) reports that Building A consumes 95.25 GJ annually for operation (electricity: 6397 kWh/yr; natural gas 65.78 MBtu/yr). Heating and miscellaneous gas equipment take up the greatest portion (51.80 GJ/yr). The

second greatest domain is 17.60 GJ/yr for domestic hot water (DHW) heating. Total energy use is not identical with the protocol house, but only 6% less than an estimate of the BA house normalized to the conditioned floor area of Building A (101.41 GJ/yr). Simulated data is similar to the meter data. Total annual energy consumption is calculated as 99.34 GJ (4% difference). Energy use distribution also presents a similar pattern, but air-conditioning and electric appliances are expected to consume more, whereas water, DHW, and lighting use less. It appears that relatively greater difference in cooling and interior equipment between the actual and simulation data result from the difference in behavioral patterns (Building A occupants usually take a long leave during summer.). Large difference in heating, lighting, and equipment use between the simulation and the BA house is due primarily to differences in input loads, because the simulation conducted with actual data as available as possible. Different inputs in conditioning systems, lighting devices, and efficiencies resulted in inconsistency of the energy use pattern. That said, overall, simulation results demonstrate that input data and geometry appear to reflect actual conditions and allowable to use for setting up a baseline model.

Similarly, Building B (Net zero energy building) was also simulated with the same inputs for unknown values. This experiment, however, does not take the reported data for it, because of some of biased simulation inputs, occupancy schedule, heating/cooling set point, internal loads, etc., show disagreement with field data, and field data had been occasionally incompletely monitored. So, the simulation results were examined and compared with the baseline that the design team initially defined based on the average household energy use in Seoul (Appendix H, Fig. 5.1.4 (b)). Building B was supposed to be a passive house. The energy produced by employing active mechanical technologies (a wind turbine and photovoltaic panels) meets the rest of operative energy demand. During design stages, efficiency of this building was also expected to follow the ASHRAE Standard 90.1 2004, as the simulation model for LEED credits reduced end-use energy by about 56.2 % with renewable energy supply of 77.18 kWh/m²yr (baseline: 139.27 kWh/m²yr; proposed: 61.30 kWh/m²yr; an initial goal was 63.7% energy reduction to the ASHRAE 90.1 2004 code.).

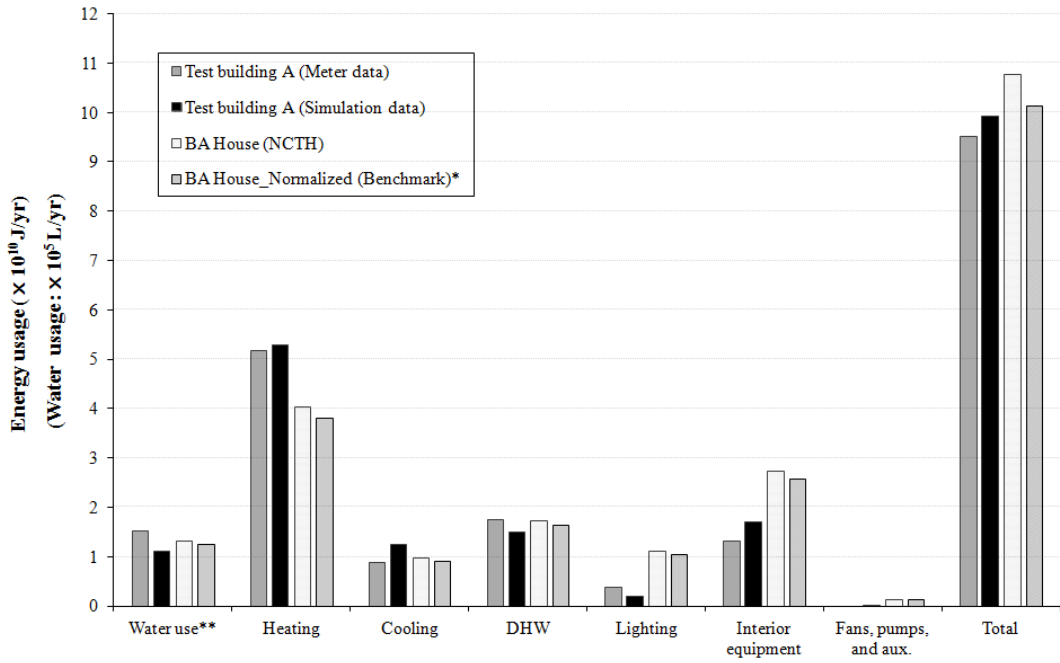

(a) Test building A

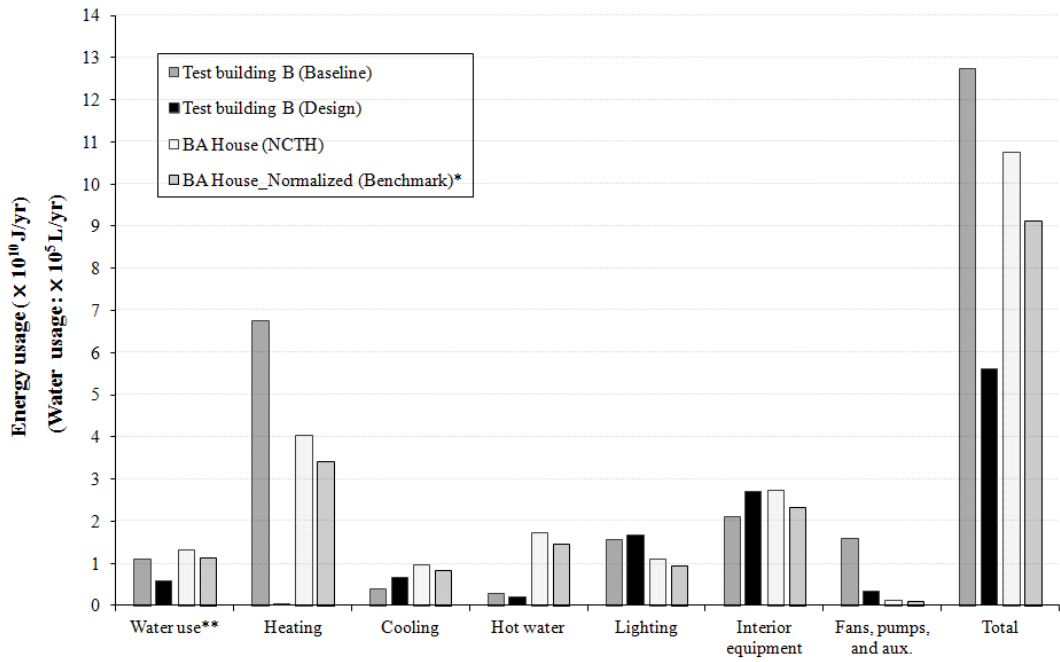

(b) Test building B (NZEB)

Fig. 5.1.4 Energy use breakdown of a reference building (BA house) and simulation results of test buildings

Building B demands 56.13 GJ/yr for operation. Annual renewable energy production is 19.6MWh/yr from the BIPV and 144.7kWh/yr from a wind turbine (Appendix H, Table H.10), generating total electricity of 62.64kWh/m²/yr (71.19

GJ/yr). As a result, this building achieves a site-NZEB definition by offsetting the demand by on-site energy production. The residual electricity of 13.21kWh/m²yr (15.06 GJ/yr) is assumed to be sold back to the grid. The greatest reduction occurs in heating (from 67.70 to 0.51 GJ/yr). High-performance insulation (due to the use of triple glazing, 430mm and 350mm polystyrene for the roof and ground floor respectively, etc.) and a high-efficient GSHP are dominant players for the reduced heating energy. Water use is also slightly reduced to 5.72E+4 L/yr, due to water reuse facilities. However, it should be noted that other domains other than heating and water consume more or a little less than the baseline. Cooling demand increased from 3.96 GJ to 6.60 GJ/yr due to the thickened envelope. Also, even if Building B adopts high efficient home appliances and lighting devices, energy consumption through electric equipment also increased from 21.1 GJ to 27.0 GJ/yr.

5.2 Emergy analysis of the case study buildings

5.2.1 Emergy synthesis of Building A (Baseline)

Emergy synthesis (the emergy evaluation procedure) for Building A was carried out to establish a baseline. From an environmental perspective, a building is generally conceived of as a climate-modifying machine that can be decomposed into five discrete components: (1) site work, (2) building structure, (3) building skin (envelope), (4) mechanical systems and equipment, and (5) indoor spaces (interior) (Braham, 2015; Yi and Braham, 2015). Even if this classification depends on the degree of spatial distinction and functional independency in material allocation, grouping building elements into these modules is consistent with the system network models presented in Chapter 4, and thermodynamic interactions of those physical entities reveal the characteristic systematic organization of the building energy dynamics (Braham, 2015). In order to make emergy flow measurement comply with the components of the system network definition, it is assumed that building system processes are divided largely into two parts: (1) operation that periodically harnesses energy for indoor thermal comfort and other human purposes; (2) manufacturing/maintenance for producing/sustaining the building form that is, in effect, a huge reservoir of mass and energy content; Total global environmental cost is obtained by combining emergy of each part. Note the solar transformities referenced

to the global solar energy baseline of 15.2E+24 sej/yr (Brown and Ulgiati, 2010). If the transformity of an item is not available in the literature, to enhance data quality, it was estimated by analyzing ingredients. Mean values from various sources were used for estimating life spans of materials and components (Appendix N, Table N.3).

Table 5.2.1 Emergy synthesis of site work and structure (Building A, baseline)

Item	Specification	Data	Unit	UEV (sej/unit)	Ref.	Life (yr)	Emergy (E15 sej)	Intensity (E15 sej/yr)
<i>Site work</i>								
Pavement	Concrete, Cast-in-Place gray	5361	kg	2.32E+12	[35]	78	12.44	0.16
	Concrete, Cast-in-Place gray	2028	kg	2.32E+12	[35]	78	4.70	0.06
	Concrete, Cast-in-Place gray	905	kg	2.32E+12	[35]	78	2.10	0.03
	Wood plank, 2" Oak	7142	kg	3.32E+12	[35]	38	23.71	0.62
Driveway	Cement asphalt, 4"	13332	kg	4.33E+12	[37]	78	57.73	0.74
	Gravel base, 2"	35553	kg	2.15E+12	[37]	78	76.44	0.98
<i>Sum</i>	w/o service	64.32	ton				177.12	2.59
	w service							3.00
<i>Structure</i>								
Vertical frame	Column, Steel	560	kg	6.68E+12	[35]	65	3.74	0.06
	Beam, Steel(ASTM A992)	1374	kg	6.68E+12	[35]	65	9.18	0.14
	Lumber frame, 2 x 4, 16"O.C	724	kg	1.42E+12	[35]	65	1.03	0.02
	Sheathing, 1/2" plywood OSB	639	kg	2.32E+12	[35]	65	1.48	0.02
Roof frame	Block wall, Concrete Masonry Units	29564	kg	2.17E+12	[35]	78	64.15	0.82
	Rafter, 2 x 10, 24" O.C	1794	kg	1.42E+12	[35]	65	2.55	0.04
Foundation	Sheathing, 1/2" plywood - OSB	1416	kg	2.32E+12	[35]	65	3.29	0.05
	4" granular fill	35500	kg	2.19E+12	[37]	78	77.75	1.00
	0.23" HDPE	32	kg	8.49E+12	[35]	78	0.27	0.003
	4" Reinforced Concrete, Cast-in-situ	44374	kg	2.32E+12	[35]	78	102.95	1.32
<i>Sum</i>	5.4% of Concrete	7824	kg	6.68E+12	[35]	78	52.26	0.67
	w/o service	123.80	ton				318.64	4.14
	w service							5.85

Note: 1. Top soil loss and natural landscape is not considered.

Table 5.2.2 Emergy synthesis of building envelope (Building A, baseline)

Item	Specification	Data	Unit	UEV (sej/unit)	Ref.	Life (yr)	Emergy (E15 sej)	Intensity (E15 sej/yr)
<i>Walls</i>								
External brick	Brick-common (6lb/unit)	15444	kg	3.57E+12	[35]	78	55.14	0.71
	Vapor barrier, HDPE	15	kg	8.49E+12	[35]	78	0.13	0.002
	Insulation, fiberglass fiber batt (R-11)	61	kg	3.86E+12	[35]	67	0.24	0.004
	1/2" Gypsum wall board- 2ply	1867	kg	1.61E+12	[142]	52	3.01	0.06
	Interior finish, acrylic paint	23	kg	2.45E+13	[35]	12	0.57	0.05
External block	Cement base stucco	5604	kg	3.72E+12	[35]	50	20.85	0.42
	Binder, Mortar (1.17lb/brick unit)	481	kg	3.72E+12	[35]	50	1.79	0.04
	Vapor barrier, HDPE	20	kg	8.49E+12	[35]	50	0.17	0.003
	Insulation, 2" Exp. Polystyrene	230	kg	1.11E+13	[124]	67	2.55	0.04
	1/2" Gypsum wall board- 2ply	2457	kg	1.61E+12	[142]	52	3.96	0.08
	Interior finish, acrylic paint	31	kg	2.45E+13	[35]	12	0.75	0.06
<i>Roof</i>								
	Roofing, asphalt shingle 1/4"	1895	kg	4.42E+13	[37]	31	83.77	2.70
	Insulation, fiberglass fiber batt, 2"	34	kg	3.86E+12	[35]	67	0.13	0.002
	Underlayment, 15lb felt paper	193	kg	6.92E+12	[124]	31	1.34	0.04
<i>Chimney</i>								
	Brick-common (6lb/unit)	7505	kg	3.57E+12	[35]	78	26.79	0.34
	Binder, Mortar (1.17lb/brick unit)	1468	kg	3.72E+12	[35]	78	5.46	0.07
<i>Windows</i>								
	Frame, wood	1366	kg	3.38E+12	[35]	38	4.62	0.12
	Double glazing, float glass (thick. 0.47")	1680	kg	1.27E+13	[35]	33	21.33	0.65
	Interior finish, acrylic paint	34	kg	2.45E+13	[35]	12	0.84	0.07
<i>Exterior doors</i>								
Doors	Frame/Panel, wood	187	kg	3.38E+12	[35]	31	0.63	0.02
	Double glazing, float glass (thick. 0.47")	51	kg	1.27E+13	[35]	31	0.65	0.02
Garage entrance	Casing frame, Aluminum	690	kg	2.04E+13	[35]	31	14.07	0.45
	Interior finish, acrylic paint	9	kg	2.45E+13	[35]	12	0.22	0.02
	Door, Aluminum	1862	kg	2.04E+13	[35]	31	37.98	1.23
<i>Ground floor</i>								
Insulation cover	Concrete (thick. 40mm)	12897	kg	2.32E+12	[35]	67	29.92	0.45
Slab cover	HDPE (double layer, thick. 0.2mm)	11353	kg	1.11E+13	[35]	67	126.01	1.88
	Insulation, 1" Exp. Polystyrene	175	kg	1.11E+13	[35]	67	1.94	0.03
<i>Sum</i>	w/o service	67.63	ton				559.81	11.71
	w service							13.36

Note: 1. Emergy inputs of land use and machine cost for building manufacturing were not considered.

Table 5.2.3 Emergy synthesis of mechanical systems and pipe/duct work (Building A, baseline)

Item	Specification	Data	Unit	UEV (sej/unit)	Ref.	Life (yr)	Emergy (E15 sej)	Intensity (E15 sej/yr)
<i>Drainage system and pipe work</i>								
Rainwater gutter	Aluminum alloy (thick. 0.03")	47	kg	2.04E+13	[35]	38	0.97	0.03
	Water sink	7	kg	6.60E+12	[37]	17	0.05	0.003
Water pipes	Carbon Steel (D50mm supply, D25mm)	363	kg	6.60E+12	[37]	47	2.39	0.05
	PVC (drainage)	119	kg	9.45E+12	[35]	47	1.13	0.02
<i>HVAC, wiring, and duct work</i>								
Gas furnace	Bryant 355AAV	92	kg	1.08E+13	[138]	19	0.99	0.05
Air conditioner	Bryant 552A	76	kg	1.08E+13	[138]	15	0.82	0.05
Air duct	Galvanized steel(supply and return)	673	kg	6.60E+12	[37]	17	4.44	0.26
Pipe and duct	Insulation (polystyrene, thick. 15mm)	90	kg	1.11E+13	[35]	47	1.00	0.02
Electric wiring	Copper wire	183	kg	1.09E+14	[124]	67	19.95	0.30
<i>Sum</i>	w/o service	1.75	ton				32.77	0.86
	w service							1.69

Table 5.2.4 Emergy synthesis of interior work (Building A, baseline)

Item	Specification	Data	Unit	UEV (sej/unit)	Ref.	Life (yr)	Emergy (E15 sej)	Intensity (E15 sej/yr)
<i>Ceilings</i>								
Roof ceiling	Ceiling joist 2 x 10, 24" O.C	1713	kg	1.42E+12	[37]	65	2.43	0.04
	Gypsum board 5/8"	2253	kg	1.61E+12	[142]	52	3.63	0.07
Finish	Interior finish, acrylic paint	50	kg	2.45E+13	[35]	11	1.21	0.11
Floor ceiling	Ceiling Joist 2 x 10, 24" O.C	1537	kg	1.42E+12	[37]	65	2.18	0.03
	Gypsum board 5/8"	2021	kg	1.61E+12	[142]	52	3.25	0.06
Finish	Interior finish, acrylic paint	44	kg	2.45E+13	[35]	11	1.09	0.10
<i>Interior floor</i>								
First floor	Hardwood flooring 7/8"	3230	kg	1.42E+12	[37]	57	4.59	0.08
	Floor truss 24" O.C	1537	kg	1.42E+12	[37]	65	2.18	0.03
Ground floor	Hardwood flooring 7/8"	3413	kg	1.42E+12	[37]	57	4.85	0.09
<i>Interior stair</i>								
Structure	Frame, 2 x 6, wood joist	22	kg	1.42E+12	[37]	65	0.03	0.0005
	Hardwood Flooring 7/8"	81	kg	1.42E+12	[37]	57	0.12	0.002
Finish	Interior finish, acrylic paint	1	kg	2.45E+13	[35]	11	0.03	0.002
<i>Interior walls</i>								
	Lumber frame, 2 x 4, 16"O.C	4166	kg	1.42E+12	[37]	65	5.92	0.09
	1/2" Gypsum wall board	10740	kg	1.61E+12	[142]	52	17.29	0.33
Finish	Interior finish, acrylic paint	269	kg	2.45E+13	[35]	11	6.60	0.60
<i>Doors</i>								
Frame/Panel	Wood	662	kg	2.64E+12	[35]	31	1.75	0.05
Finish	Interior finish, acrylic paint	13	kg	2.45E+13	[35]	12	0.32	0.03
<i>Electronic appliances, furniture, lighting and housewares</i>								
Bath	Bathtub, porcelain	35	kg	4.93E+12	[35]	30	0.17	0.01
	Bathtub, porcelain on steel	43	kg	4.93E+12	[35]	30	0.21	0.01
	Shower base, terazzo	68	kg	4.93E+12	[35]	30	0.34	0.01
	Toilets, TOTO CST764SG	148	kg	4.93E+12	[35]	30	0.73	0.02
	Lavatories	64	kg	4.93E+12	[35]	30	0.31	0.01
Kitchen	Kitchen Cabinets	428	kg	6.60E+12	[37]	35	2.83	0.08
Appliances	Washing Machine, Frigidaire	100	kg	1.08E+13	[138]	15	1.08	0.07
	Dryer, Frigidaire	59	kg	1.08E+13	[138]	15	0.63	0.04
	Dishwasher, Frigidaire	36	kg	1.08E+13	[138]	15	0.39	0.03
	Wall-Oven, Electric	64	kg	1.08E+13	[138]	15	0.69	0.05
	Cooktop Range, Gas	18	kg	1.08E+13	[138]	15	0.19	0.01
	Refrigerator, LG LRFC21755	126	kg	1.08E+13	[138]	15	1.36	0.09
	Microwave Oven	14	kg	1.08E+13	[138]	15	0.15	0.01
	Computer	9	kg	3.20E+13	[138]	7	0.29	0.04
Lighting fixtures and luminaires	Compact fluorescent (14 ea.)	210	\$	1.76E+12	[12]	24	0.37	0.02
	Incandescent (42 ea.)	684	\$	1.76E+12	[12]	24	1.20	0.05
	Other (11 ea.)	308	\$	1.76E+12	[12]	24	0.54	0.02
Furniture and goods	Furnishings	4789	\$	1.76E+12	[12]	24	8.43	0.35
	Misc. goods	1074	\$	1.76E+12	[12]	24	1.89	0.08
Sum	w/o service	42.13	ton				79.26	2.72
	w service							4.52

Table 5.2.5 Emergy synthesis of maintenance and renewable energy inputs
(Building A, baseline)

Item	Specification	Data	Unit	UEV (sej/unit)	Ref.	Emergy (E15 sej)	Intensity (E15 sej/yr)
<i>Various goods and services for operation and maintenance</i>							
Living supplies	Food and apparel	5141	\$/yr	1.76E+12	[12]		9.05
Maintenance	Building structure	259	\$/yr	1.76E+12	[12]		0.46
	HVAC/Water systems	89	\$/yr	1.76E+12	[12]		0.16
	Appliances/Equipment	936	\$/yr	1.76E+12	[12]		1.65
	Furnishings	779	\$/yr	1.76E+12	[12]		1.37
	Disposal systems	10	\$/yr	1.76E+12	[12]		0.02
Public service	Property tax	2548	\$/yr	1.76E+12	[12]		4.48
<i>Water</i>	Public water supplies	300438	kg/yr	3.01E+08	[35]		0.09
<i>Renewable sources</i>							
Solar	Transmission to indoor space	6.25E+10	J/yr		1 [142]		0.0001
<i>Nonrenewable sources/Fossil fuel use</i>							
Heating/Hot water	Natural gas	6.79E+10	J/yr	7.14E+04	[12]		4.85
Cooling/Equipment	Electricity	3.15E+10	J/yr	2.80E+05	[12]		8.81
Waste	Solid waste	2353	kg/yr	4.49E+12	[35]		10.56
<i>Construction service (labor and indirect cost)^a</i>		210707	\$	1.76E+12	[24]	370.85	6.86
<i>Total (manufacturing w/ service)</i>		299.63	ton			1166.36	21.57
<i>Total (manufacturing w/o service)</i>		299.63	ton			1537.21	28.42
<i>Total (construction + operation and maintenance)</i>		606.21	ton				59.35

a. Alternative calculation : $1.01E+15 \text{ sej/m}^2 [35] \times 340.73 \text{ m}^2 = 344.14E+15 \text{ sej}$

5.2.2 Emergy synthesis of Building B (NZEB)

Table 5.2.6 through Table 5.2.10 present the results of emergy accounting for the manufacturing of the test building. Service for construction includes all the embodied investment from human economy (human labor, tax, transportation, etc.) other than direct material deposits. It is estimated with indirect construction cost and emergy per dollar (Bastianoni et al, 2009) (there found no significant difference with the Burnakarn (1998)'s estimation).

On the other hand, the taxonomy may not be clear for all technical items. Some of them are not classified simply into mechanical systems but according to the location of the subsystem that main controllers serve. For example, the wind turbine is considered *site work*, because its control systems are outside. In a similar vein, borehole and casing pipes of GSHP are subject to *systems* though they are in effect under the ground. As for the BIPV, hardware for collecting solar energy is par of the *envelope*, whereas battery cabinets are in *systems*.

The mass of each component measures 27.38 ton (site work, 5.1%), 307.99 ton

(structure, 57.3%), 163.22 ton (envelope, 30.3%), 13.26 ton (systems, 2.5%), and 25.92 ton (interior, 4.8%), which gives a total weight of 537.77 ton. The structure exhibits the largest deposits of mass, followed by the envelope.

In site work, the large mass of block pavement gives the greatest emergy content and intensity ($6.70\text{E}+14\text{sej/yr}$, w/o service), but wind turbine catches up the intensity due to greater UEV and shorter lifetime. For structure, concrete foundation and steel structure contribute a major share in both emergy ($8.02\text{E}+17\text{sej}$) and an intensity ($1.07\text{E}+16\text{sej/yr}$), while others are confined to a small portion.

Table 5.2.7 shows the accounting result of the envelope. It was subdivided into three units (wall, roof, and floor) by tectonic contacts. An emergy content (w/o service) of the walls is $2.13\text{E}+17\text{sej}$ with an intensity of $5.24\text{E}+15\text{sej/yr}$. The roof gives an emergy of $4.10\text{E}+17\text{sej}$ and an intensity of $1.44\text{E}+16\text{sej/yr}$. An emergy and intensity of the floor are, respectively, $2.64\text{E}+17\text{sej}$ and $3.40\text{E}+15\text{sej/yr}$. It is important to notice that the intensity of the roof is far greater than others (175%, 324% increase than the walls and floor, respectively), due to the large energy concentration of roof material (zinc) and solar energy collectors.

System (Table 5.2.8) is subdivided into three parts in order to separate: (1) water-related equipment, (2) infrastructural elements for HVAC and electricity use, and (3) supporting elements (batteries of BIPV and thermostat/lighting control units). An emergy content (w/o service) of each is $2.78\text{E}+16\text{sej}$ (24.9%), $5.48\text{E}+16\text{sej}$ (49.2%), and $2.89\text{E}+16\text{sej}$ (25.9%). Portions of intensities are distributed in a similar fashion. However, even if the supporting unit is far lighter (0.92ton) than other two units (12.34ton), we notice that its UEV ($3.14\text{E}+13\text{sej/kg}$) becomes greater (the final UEV of other two is $1.44\text{E}+13\text{sej/kg}$).

Interiors (Table 5.2.9) is departmentalized in order to assort parts in tectonic contact and free-standing interior elements (furniture, electric appliances, lighting devices, etc.). The interior walls and floor refer to physical assemblies bearing no structural/thermal loads. Most of building elements in emergy accounting are, basically, evaluated based on mass/volume. That said, it is necessary to note that it is more accurate to estimate the emergy values of home appliances/house wares based on market prices, so that they account for various service inputs in addition to material cost (difference between mass-based and market price-based estimates was around 33.8%). We obtained monetary data from design documents, while survey results from Siniavskaja (2008) were used to estimate expenditure for furnishings and

goods. Total mass of interior Findings show electronic appliances and goods entail the greatest energy intensity ($2.24\text{E}+15\text{sej/yr}$) due to short life expectancy and human services.

Table 5.2.10 presents annually renewed environmental inputs and system services. Maintenance costs include tax imposed on the building, spending for repair/replacement, and living supplies (for this study, we consider only major inputs such as food and clothes). Notice that the sum of renewable energy ($1.54\text{E}+13\text{sej/yr}$) are much less than that of purchased ones ($1.75\text{E}+16\text{sej/yr}$).

Finally, total energy for manufacturing is $4.16\text{E}+18\text{sej}$ ($4.45\text{E}+16\text{sej/yr}$) without service or $4.40\text{E}+18\text{sej}$ ($4.70\text{E}+16\text{sej/yr}$) with service. If we weigh the building with mass of water, furniture and miscellaneous gadgets for operation and maintenance, the final weight becomes 688.07 ton, giving the final intensity of $6.46\text{E}+16\text{sej/yr}$.

Table 5.2.6 Energy synthesis of site work and structure (Building B, NZEB)

Item	Specification	Data	Unit	UEV (sej/unit)	Ref.	Life (yr)	Emergy (E15 sej)	Intensity (E15 sej/yr)
<i>Site work</i>								
Wind turbine	Rotor and blade	680	kg	$1.08\text{E}+13$	[138]	20	7.34	0.37
	Control system and inverter	19	kg	$3.14\text{E}+13$	[37]	20	0.58	0.03
	Structure (steel column, thick. 3mm)	190	kg	$6.68\text{E}+12$	[35]	78	1.27	0.02
	Concrete	83	kg	$2.32\text{E}+12$	[35]	78	0.19	0.002
Cool tube	Steel pipe (rectangular, 40x40mm)	25	kg	$3.48\text{E}+12$	[78]	38	0.09	0.002
	Wood grill (cedar, thick. 20mm)	76	kg	$3.32\text{E}+12$	[35]	38	0.25	0.01
	Concrete (w/o steel, thick. 150mm)	541	kg	$2.32\text{E}+12$	[35]	78	1.25	0.02
Pond	Rain (precipitation)	10200	kg	$1.39\text{E}+08$	[135]	0.1	0.001	0.02
Pavement	Clay stone block	14640	kg	$3.57\text{E}+12$	[35]	78	52.26	0.67
	Wood deck (thick. 20mm)	570	kg	$3.32\text{E}+12$	[35]	38	1.89	0.05
	Deck support structure	361	kg	$3.48\text{E}+12$	[78]	65	1.25	0.02
<i>Sum</i>	w/o service	27.38	ton				66.39	1.20
	w service							1.35
<i>Structure</i>								
Frames	Steel (H-beam)	22158	kg	$6.68\text{E}+12$	[35]	65	148.01	2.28
Structure deck	Metal sheet (depth 75mm, thick. 1.2mm)	5234	kg	$6.68\text{E}+12$	[35]	65	34.97	0.54
Fire protection	Fireproofing plaster (thick. 16mm)	18831	kg	$3.16\text{E}+12$	[124]	65	59.50	0.92
Foundation	Granular fill (thick 200mm)	30340	kg	$2.15\text{E}+12$	[37]	78	65.23	0.84
	Concrete (thick. 60mm)	52964	kg	$2.32\text{E}+12$	[35]	78	122.88	1.58
	Reinforced concrete (thick. 200mm)	151702	kg	$2.32\text{E}+12$	[35]	78	351.95	4.51
	Steel (5.4% of concrete volume)	26760	kg	$6.68\text{E}+12$	[35]	78	178.76	2.29
<i>Sum</i>	w/o service	307.99	ton				961.30	12.95
	w service							13.58

Note: 1. Top soil loss and natural landscape is not considered.

Table 5.2.7 Emergy synthesis of building envelope (Building B, NZEB)

Item	Specification	Data	Unit	UEV (sej/unit)	Ref.	Life (yr)	Emergy (E15 sej)	Intensity (E15 sej/yr)
<i>Walls</i>								
Window glazing	Triple glass (thick. 17mm)	2795	kg	1.27E+13	[35]	33	35.49	1.08
	Double glass (thick. 12mm)	1341	kg	1.27E+13	[35]	33	17.03	0.52
Window frames	Aluminum	264	kg	2.04E+13	[35]	38	5.39	0.14
	PVC	283	kg	9.45E+13	[35]	38	26.75	0.70
Window shading	Blind screen	430	\$	1.76E+12	[12]	10	0.76	0.08
Exterior door	Steel	113	kg	6.68E+12	[35]	31	0.76	0.02
	Paint	2	kg	2.45E+13	[35]	11	0.04	0.004
Substructure	Steel pipe (rectangular, 40x40mm)	741	kg	3.48E+12	[78]	65	2.58	0.04
Wall studs	Channel (100x50x2mm,100x45x0.8mm)	3375	kg	3.48E+12	[78]	65	11.75	0.18
Energy collector	Solar cell	9	m ²	9.49E+14	[154]	20	8.20	0.41
Panels	Gypsum board (double, thick. 12.5 mm)	6641	kg	1.61E+12	[142]	52	10.69	0.21
	Cement board (double, thick. 6mm)	3925	kg	3.72E+12	[35]	52	14.60	0.28
Insulation	Glass wool 32K (double, thick. 90mm)	1844	kg	3.86E+12	[35]	67	7.12	0.11
	Expanded polystyrene (thick. 160mm)	1573	kg	1.11E+13	[124]	67	17.46	0.26
Interior finish	Paint	73	kg	2.45E+13	[35]	11	1.79	0.16
	Paper	11	kg	3.83E+12	[124]	11	0.04	0.004
Exterior finish	Terracotta tile cladding	6359	kg	4.93E+12	[35]	50	31.35	0.63
	Wood siding (reused)	946	kg	1.09E+13	[35]	50	10.31	0.21
Miscellaneous	Support hardware (galvanized steel)	2508	kg	3.48E+12	[78]	65	8.73	0.13
Louver	Wood folding shutter	316	kg	7.55E+12	[35]	31	2.39	0.08
<i>Roof</i>								
Glazing	Triple glass (thick. 17mm)	88	kg	1.27E+13	[35]	33	1.11	0.03
Casing frame	PVC	7	kg	9.45E+12	[35]	38	0.06	0.002
Substructure	Steel pipe (rectangular, 40x40mm)	3212	kg	3.48E+12	[78]	65	11.18	0.17
Exterior finish	Zinc	1085	kg	1.09E+14	[142]	31	118.30	3.82
	Aluminum	724	kg	2.04E+13	[35]	31	14.76	0.48
Louver	Aluminum	33	kg	2.04E+13	[35]	31	0.68	0.02
Vapor barrier	HDPE (double layer, thick. 0.2mm)	4	kg	8.49E+12	[35]	78	0.03	0.0004
Roof panels	Plywood (thick. 12mm)	2353	kg	2.32E+12	[35]	38	5.46	0.14
Insulation	Expanded polystyrene (thick. 430mm)	3942	kg	1.11E+13	[35]	67	43.75	0.65
Planting	Sedum-planted green area	78	m ²	5.42E+14	[32]	78	42.28	0.54
Photovoltaic	Solar module (1326x716mm, 180EA)	174	m ²	9.49E+14	[31]	20	165.13	8.26
	Support hardware (galvanized steel)	407	kg	3.48E+12	[78]	65	1.42	0.02
Light pipe	Dome and diffuser (polycarbonate)	7	kg	9.27E+12	[35]	33	0.07	0.002
Light pipe:	Tube and casing (aluminum)	38	kg	2.04E+13	[35]	33	0.77	0.02
Solar thermal	Solar energy collector	142	kg	3.78E+13	a	20	5.36	0.27
<i>Ground floor</i>								
Insulation	Expanded polystyrene (thick. 350mm)	556	kg	1.11E+13	[124]	67	6.17	0.09
Vapor barrier	HDPE (double layer, thick. 0.2mm)	4	kg	8.49E+12	[35]	78	0.03	0.0004
Insulation cover	Concrete (thick. 60mm)	41034	kg	2.32E+12	[35]	78	95.20	1.22
	Lightweight concrete (thick. 40mm)	23261	kg	3.72E+12	[35]	78	86.53	1.11
Slab cover	Cement mortar (thick. 30mm)	20476	kg	3.72E+12	[35]	78	76.17	0.98
<i>Sum</i>	w/o service	163.22	ton				887.69	23.07
	w service							23.86

a. Estimated in this study (see Appendix B)

Table 5.2.8 Emergy synthesis of mechanical systems and pipe/duct work
(Building B, NZEB)

Item	Specification	Data	Unit	UEV (sej/unit)	Ref.	Life (yr)	Emergy (E15 sej)	Intensity (E15 sej/yr)	
<i>Water treatment system and pipe work</i>									
Water reuse equipment	Septic and equalization tank (2 ton each)	317	kg	6.68E+12	[35]	47	2.12	0.05	
	Membrane bio reactor (1ton)	200	kg	3.14E+13	[37]	15	6.28	0.42	
Rainwater storage	Stainless steel tank (30 ton)	2379	kg	6.68E+12	[35]	47	15.89	0.34	
Grey water storage	Stainless steel tank (1 ton)	79	kg	6.68E+12	[35]	47	0.53	0.01	
Supply pumps	Motor pump	9	kg	1.08E+13	[138]	16	0.10	0.01	
Water pipes	Carbon Steel (D50mm supply, D25mm)	257	kg	6.68E+12	[35]	47	1.71	0.04	
	PVC (drainage)	72	kg	9.45E+12	[124]	47	0.68	0.01	
	Insulation (polystyrene, thick. 15mm)	44	kg	1.11E+13	[124]	47	0.49	0.01	
<i>HVAC, wiring, and duct work</i>									
Ventilation duct	Galvanized steel(supply and return)	1487	kg	3.48E+12	[78]	17	5.18	0.30	
	Insulation (polystyrene, thick. 20mm)	152	kg	1.11E+13	[124]	17	1.68	0.10	
Cool tube duct	Stainless steel (D300mm, thick. 1.2mm)	538	kg	6.68E+12	[35]	17	3.60	0.21	
Heat recovery	Casing and fan (steel, thick. 1.2mm)	33	kg	1.08E+13	[35]	13	0.36	0.03	
	Insulation (glass wool, thick. 20mm)	1	kg	3.86E+12	[35]	13	0.004	0.0003	
Electric wiring	Copper wire	133	kg	1.09E+14	[124]	67	14.44	0.22	
GSHP	Heat pump	296	kg	1.08E+13	[138]	16	3.19	0.20	
	Borehole pipe (PVC, D30mm)	162	kg	9.45E+12	[35]	47	1.53	0.03	
	Casing pipe (steel, D150mm)	3390	kg	3.48E+12	[35]	47	11.80	0.25	
	Grouting material (Bentonite)	1447	kg	2.15E+12	[35]	47	3.11	0.07	
	Buffer tank (1ton)	512	kg	6.68E+12	[35]	47	3.42	0.07	
	Water heater	16	kg	1.08E+13	[138]	14	0.17	0.01	
	Expansion tank (200L)	304	kg	6.68E+12	[35]	47	2.03	0.04	
	Circulation pipes	60	kg	6.68E+12	[35]	47	0.40	0.01	
	Circulation pumps	16	kg	1.08E+13	[138]	16	0.17	0.01	
	Pipe insulation (thick. 15mm)	10	kg	1.11E+13	[124]	47	0.11	0.002	
	Air conditioner	Ceiling cassette unit (one-way)	88	kg	1.08E+13	[138]	15	0.95	0.06
	Heating coil	Polybutylene pipe (thick. 1.6, D10mm)	120	kg	9.45E+12	[35]	47	1.13	0.02
		Distribution controller	8	kg	1.08E+13	[35]	20	0.09	0.004
Solar thermal heating system	Controller and heat exchanger	14	kg	1.08E+13	[138]	20	0.15	0.01	
	Drain and hot water tank	180	kg	6.68E+12	[35]	47	1.20	0.03	
	Pumps	7	kg	1.08E+13	[138]	16	0.08	0.005	
	Pipe (stainless steel, D10mm)	5	kg	6.68E+12	[35]	47	0.03	0.001	
	Insulation (glass wool, thick. 25mm)	1	kg	1.11E+13	[124]	47	0.01	0.0002	
<i>Other systems</i>									
Control system	Sensor, switching server, and displayer	120	kg	3.14E+13	[37]	29	3.77	0.13	
Storage/battery	Battery cabinets for solar energy systems	800	kg	3.14E+13	[37]	24	25.12	1.05	
<i>Sum</i>	w/o service	13.26	ton				111.52	3.74	
	w service							4.05	

Table 5.2.9 Energy synthesis of interior work (Building B, NZEB)

Item	Specification	Data	Unit	UEV (sej/unit)	Ref.	Life (yr)	Emergy (E15 sej)	Intensity (E15 sej/yr)
<i>Interior walls/doors</i>								
Wall studs	Channel (100x50x2mm)	1431	kg	3.48E+12	[78]	65	4.98	0.08
Panels	Gypsum board (double, thick. 12.5 mm)	3157	kg	1.61E+12	[142]	52	5.08	0.10
Interior finish	Paint	63	kg	2.45E+13	[35]	11	1.55	0.14
	Wood siding (reused)	98	kg	1.09E+13	[35]	50	1.07	0.02
	Paper	1	kg	3.83E+12	[124]	11	0.003	0.0003
	Ceramic tile (thick. 5mm)	127	kg	4.93E+12	[35]	12	0.63	0.05
	Adhesives	37	kg	6.12E+11	[35]	12	0.02	0.002
Interior doors	Wood	92	kg	3.32E+12	[35]	31	0.31	0.01
<i>Interior floor</i>								
Floor finish	Hardwood flooring (thick. 15mm)	1338	kg	1.42E+12	[37]	57	1.90	0.03
	Ceramic tile flooring (thick. 10mm)	3361	kg	4.93E+12	[35]	57	16.57	0.29
	Wood deck (thick. 20mm)	364	kg	3.32E+12	[35]	38	1.21	0.03
	Deck support structure (steel pipe)	230	kg	3.48E+12	[78]	65	0.80	0.01
	Polyvinyl tile	142	kg	1.02E+13	[35]	12	1.44	0.12
	Adhesives	983	kg	6.12E+11	[37]	12	0.60	0.05
<i>Ceiling</i>								
Miscellaneous	Support hardware (galvanized steel)	439	kg	3.48E+12	[78]	65	1.53	0.02
Panels	Gypsum board (double, thick. 9.5 mm)	4825	kg	1.61E+12	[142]	52	7.77	0.15
Interior finish	Paint	84	kg	2.45E+13	[35]	11	2.05	0.19
<i>Electronic appliances, furniture, lighting and housewares</i>								
Home theater	UN55B6000VF	8250	\$	1.76E+12	[12]	15	14.52	0.97
Desktop	DB-X150-CA160/P2370 23"	810	\$	1.76E+12	[12]	15	1.43	0.10
Laptop	NP-X360	690	\$	1.76E+12	[12]	15	1.21	0.08
Laser printer	CLP 315K	180	\$	1.76E+12	[12]	15	0.32	0.02
Fridge-freezer	HBRL26GUL/R	1620	\$	1.76E+12	[12]	15	2.85	0.19
Freezer	HRM316GWMQ	890	\$	1.76E+12	[12]	15	1.57	0.10
Electric oven	HSB-C427AST/DER-3800GB	1140	\$	1.76E+12	[12]	15	2.01	0.13
Washing machine	SEW-HAR149AUR	650	\$	1.76E+12	[12]	15	1.14	0.08
Furniture	Furnishings	4789	\$	1.76E+12	[12]	24	8.43	0.35
	Miscellaneous goods	493	\$	1.76E+12	[12]	24	0.87	0.04
Bath	Bathub, porcelain	35	kg	4.93E+12	[35]	30	0.17	0.01
	Toilets	49	kg	4.93E+12	[35]	30	0.24	0.01
	Lavatories	16	kg	4.93E+12	[35]	30	0.08	0.003
Lighting fixtures and luminaires	LED, 20W flood light (2 ea.)	44	\$	1.76E+12	[12]	24	0.08	0.003
	LED, 24W down light (38 ea.)	950	\$	1.76E+12	[12]	24	1.67	0.07
	LED, 40W panel light (6 ea.)	240	\$	1.76E+12	[12]	24	0.42	0.02
	LED, 60W panel light (23 ea.)	920	\$	1.76E+12	[12]	24	1.62	0.07
	Fluorescent light tube, 24W (7 ea.)	105	\$	1.76E+12	[12]	24	0.18	0.01
<i>Sum</i>	w/o service	25.92	ton				86.33	3.54
	w service							4.20

Table 5.2.10 Emergy synthesis of maintenance and renewable energy inputs
(Building B, NZEB)

Item	Specification	Data	Unit	UEV (sej/unit)	Ref.	Emergy (E15 sej)	Intensity (E15 sej/yr)
<i>Various goods and services for operation and maintenance</i>							
Living supplies	Food and apparel	5346	\$/yr	1.76E+12	[12]		9.41
Maintenance	Building structure	259	\$/yr	1.76E+12	[12]		0.46
	HVAC/Water systems	89	\$/yr	1.76E+12	[12]		0.16
	Appliances/Equipment	936	\$/yr	1.76E+12	[12]		1.65
	Furnishings	779	\$/yr	1.76E+12	[12]		1.37
	Disposal systems	10	\$/yr	1.76E+12	[12]		0.02
Public service	Property tax	2548	\$/yr	1.76E+12	[12]		4.48
<i>Water</i>	Public water supplies	57160	kg/yr	3.01E+08	[35]		0.017
<i>Renewable sources</i>							
Solar	Absorbed to photovoltaic system	9.27.E+11	J/yr	1	[142]		0.001
	Absorbed to solar thermal system	3.44.E+10	J/yr	1	[142]		0.00003
	Transmission to indoor space	1.19E+10	J/yr	1	[142]		0.00001
Wind ^a	Kinetic energy for wind turbine	1.49.E+09	J/yr	1.07E+03	[142]		0.002
Rainwater ^b	Chemical potential of rainwater	4.31.E+08	J/yr	2.93.E+04	[142]		0.013
Geothermal heat ^c	Energy to ground heat exchanger	1.74.E+07	J/yr	1.15E+04	[135]		0.0002
Sum		9.75E+11	J/yr				0.015
<i>Construction service (labor and indirect cost)^d</i>		135425	\$	1.76E+12	[12]	238.35	2.55
<i>Total (manufacturing w/ service)</i>		537.77	ton			4160.05	44.49
<i>Total (manufacturing w/o service)</i>		537.77	ton			4398.40	47.04
<i>Total (construction + operation and maintenance)</i>		688.07	ton				64.60

a. Wind for natural ventilation was not considered.

b. Gibbs chemical energy of rainwater 4.95 J/g

c. Geothermal heat, Bentonite specific heat (800 J/kgK), density (1447kg), Delta T = 15 °C

d. Alternative calculation : $1.01E+15 \text{ sej/m}^2 [35] \times 315.69 \text{ m}^2 = 318.85E+15 \text{ sej}$

5.2.3 Comparative analysis

Odum's maximum empower principle argues that an ecosystem should construct a self-organizing structure of energy power between system components so that the system obtains power efficiently. In order to identify a relationship appeared between the compartmental hierarchies and self-organizing work of Building B, the empower value of each component was computed for Building A and B by considering multiple internal and external emergy inflows per time (Table 5.2.1~5.2.10). Each of the categories of the hierarchy is basically a building element as listed in the emergy analysis tables. For example, photovoltaic panels belong to envelope, and GSHP and water treatment equipment belongs to systems. On the other hand, operational energies and resources are categorized from where initial investment occurs to the

final end of their flows, since they are transferred all the way through the hierarchical system network. For example, natural gas and electricity for heating/cooling are distributed by systems and categorized in envelope. Systems accounts for potable water, and simultaneously, water use belongs to interiors. Following this accounting rule, Fig. 5.2.1 displays the results.

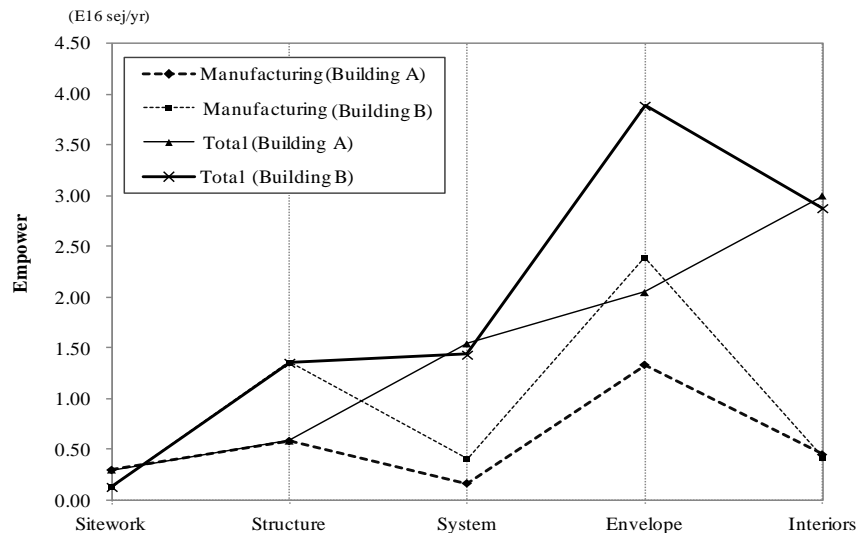

Fig. 5.2.1 Comparison of empower

Power profiles appear similar for both building types unless non-construction elements (water, operational energies, furnishings and goods) considered. For building manufacturing, empower peaks at the envelope and structure, while powers of site work, system, and interiors stay low. In terms of building thermodynamics, we may generalize from this finding that building construction processes accumulate a certain magnitude of power for the building envelope to provide thermal comfort by climate modification. Shifting attention to operation and management, engagement of the occupant's needs causes this relationship to reorganize. Empower of the system of Building A is increased by the fossil fuel use for HVAC, and interiors is also increased by the huge imports of goods and living supplies. Building A eventually reveals a power arrangement in order of site work, structure, system, envelope, and interiors, which is in parallel with the Braham (2015)'s finding of an energetic hierarchy of building components.

Building B's system power is greater overall than the non-NZEB, Building A (Fig. 5.2.1). However, empowers of system and interiors are similar to Building A. Even

though NZEB does not require operational fuels, it is noticeable that Building B's empower of system is not decreased as such, because it consumes enormous non-renewable inputs for manufacturing high-efficient HVAC/BIPV equipment. By the same token, despite the introduction of high-efficient home appliances, Building B's empower of interior use is not reduced, because it is not concerned with occupants' behavioral patterns or lifestyles regarding demand side control. Moreover, it is important to note that Building B's total empower peaks at the envelope. This is due primarily to the enormous concentration of insulation materials and the use of environmentally expensive (high transformity) resources for renewable energy production (e.g., PV panels on the roof and walls). This identifies that the ability of climate-modification and heat transfer stability provided by the envelope as well as non-renewable energy supply plays the most significant role in Building B's energy transformation mechanism. Building B sacrifices the ability to process living services for thermal comfort.

In this empower profile, we can speculate that a building self-organizes differently during different stages of development. Then, how does this structural difference of empower affect systematic behavior and the quality of system components, operational energies, and energy production? We should evaluate the change of transformity values, since they are a measure of energy quality. To identify an environmental hierarchy of building construction, Fig. 5.2.2 (a) compares the UEV of each component. Interestingly, unlike power organization, systems have the top rank for both cases ($4.43E+13$ sej/kg and $1.40E+13$ sej/kg, respectively for Building A and B). This reveals the highest-quality energy is invested in manufacturing building's mechanical systems, and thus compartmental hierarchies during the construction becomes inconsistent with the self-organizing structures towards increasing power. Meanwhile, Building B relieves the uneven distribution of energy wealth by sharing it with the envelope and interiors. Building B's construction work, at the end, earns a higher hierarchical rank (greater UEV) than the typical building in the energy hierarchy of the global environment.

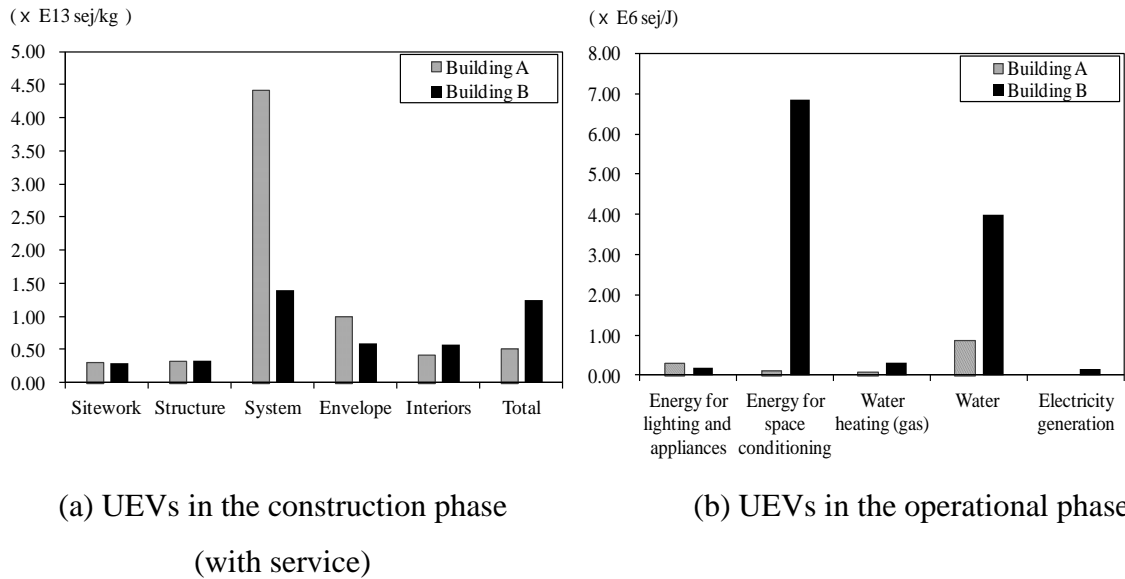

Fig. 5.2.2 Comparison of UEVs

In a similar way, emergence of the compartmental hierarchy during building operation is figured out by examining the change in UEVs (Fig.5.2.2 (b)). However, due to complexity, the estimation of an operational UEV of a building component would be biased if we simply represent mixed accumulation of different types of energies with a single unit such as mass (kg) or energy (J). For this reason, this study attempts to investigate transformities of operational environmental sources. Fig. 7 compares energy, energy inflows and transformities of Building A and B. Results indicate that the baseline consumes a larger amount of operational energy. Fossil-fuel based operation needs $6.20\text{E}+10\text{J/yr}$ for conditioning, $1.40\text{E}+10\text{J/yr}$ for water heating, and $9.80\text{E}+9\text{J/yr}$ for water use, while Building B reduces them to $5.69\text{E}+9\text{J/yr}$, $1.93\text{E}+9\text{J/yr}$, and $1.90\text{E}+8\text{J/yr}$ respectively. In contrast, energy appears greater for Building B, which leads to an increase of transformity. Though energy transformities of both cases are apparently greater than the estimates for public supply (electricity: $2.80\text{E}+5\text{sej/J}$; natural gas: $7.14\text{E}+4\text{sej/J}$ (Bastianoni, 2009); and water: $6.54\text{E}+4\text{sej/J}$ (Buenfil, 2001)), it is particularly important to note that NZEB's transformities for conditioning energy and water are far greater than Building A (Fig.5.2.2 (b)), because it demonstrates that Building B concentrates a huge amount of mass and energy to reduce the operational source use. On the other hand, electricity produced by the BIPV is environmentally cheaper than that from a fuel-fired power plant. Transformity of electricity that Building B produces measures around $1.44\text{E}+5\text{sej/J}$

(similar to $1.45E+05$ sej/J from Brown et al., 2012). It shows a mixture of renewable energy reduces energy quality. Meanwhile, even though Building B uses high-efficient electric appliances and LED lighting (Table 5.2.9), energy consumption has been increased to $3.49E+10$ J/yr, and transformity ends up lowered (Fig. 5.2.3). This reveals the rebound effect that high efficiency causes energy/material use to increase.

Based on these results, a quantity-quality relationship of each energy source is plotted as displayed in Fig. 5.2.3. Each building component of Building B contributes to high-quality energy production in small quantity, whereas Building A's components produce low-quality energy in large quantity. This demonstrates that Building B is a relatively more developed system that is placed in the upper hierarchical level of the global environment. It clearly reveals that a major target of the building development has been the production of finer energy and more power for providing indoor thermal comfort with thermodynamic minima.

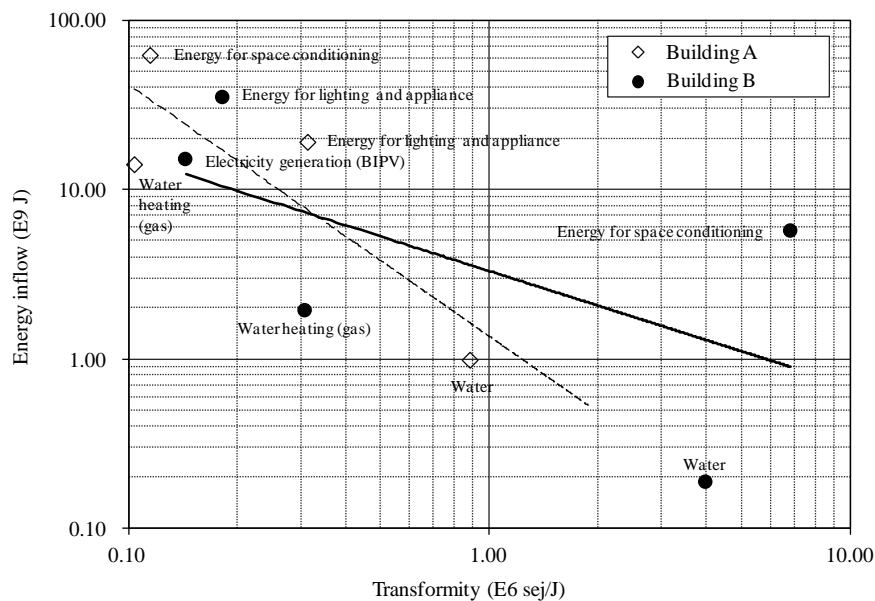

Fig. 5.2.3 Quantity-quality plot

5.3 Information analysis: Whole system (※ Numeric calculation data is presented in Appendix S)

The emergy-information integrated modeling and method (Chapter 4) were applied to evaluate the whole building system inclusive of all components within the site boundary. Note that results show the information quantity of a unit energy carrier, not the whole amount of system information. In this study, information content is

measured on a quantum basis for the sake of comparative evaluation, and also because capacity and outflow quantity of external information storage are unknown. This is why complexity (H) is termed “potential” power. Once we rigorously figure out either the inflow information quantity or transformity of building information, the potential power can turn into an actual power by multiplying it with the information content per unit quantum.

5.3.1 Annual variation during building life time (50 years)

Information analyses over the building life give a long-term strategy of comprehensive sustainable building management and design. Fig. 5.3.1 and 5.3.2 show information profiles over the entire building life (assumed to be 50 years). Since operational energy use is supposed to be identical in this time frame, yearly variation primarily show information exchanges through materials and services whose degradation and trends of replacement changes dynamically. That is, this experiment assumes that energy investment of building materials is based on the declining depreciation schedule (Appendix R).

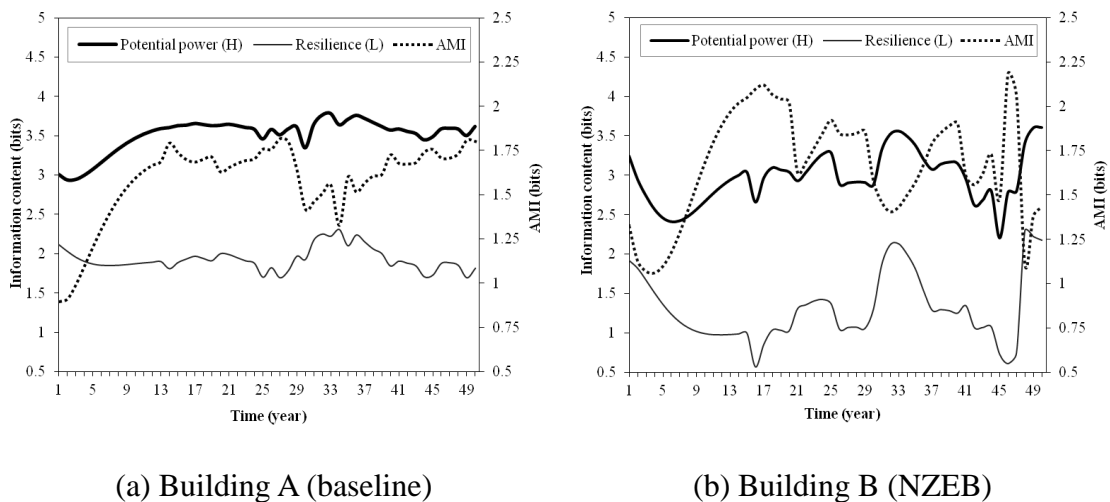

Fig. 5.3.1 Information contents of Building A and B (yearly)

The information content of each type of building reveals different results. The reading of Building A shows that the average complexity (H), resilience (L), and AMI are 3.51 bits, 1.93 bits, and 1.58 bits respectively. Building B’s average H, L, and AMI measure 2.98 bits, 1.31 bits, and 1.67 bits.

Interestingly, variation patterns are also quite different (Fig. 5.3.1). While

Building A's H and L varies relatively steadily within the observation range, Building B undergoes sharp fluctuation. Different schedules of investment and replacement of building elements give rise to the variation in the configuration of emergy networking. If replacement frequencies for building maintenance overlap at a certain time, information content of a building rapidly changes. The graphs in Fig. 5.3.1 show a number of niches at the 30th year of Building A and at the 16th, 21th, 26th to 30th, and 45th year of Building B. Building B has more bumps and niches with sharp variations, for it carries a complicated set of individual system elements (materials and equipment) that supports NZEB technologies and each of which has a different life span (see Section 5.2.2 and Appendix R). Information quantifies the synthesis of numerous contributions, frictions, and trade-offs that various emergy flows cause.

It is worth noting differences in the information indicator values during the early years (within around 10 years). Peak material expenditure for initial manufacturing causes useful information shortly to fall in common (Fig. 5.3.2 (a)). However, Power of Building B goes downhill until the 6th year (3.24 bits to 2.41 bits), and resilience descends until the 12th year (1.92 bits to 0.97 bits). This extended declination results from mixed signals of material, equipment, and service inputs that appear to cause a heavy disturbance to the system development.

Thermodynamically useful building information is likely to maximize if different source inflows even out and diverse resource availability is secured (Chapter 3). In other words, the information content of complexity (H) is generally accumulated as inflows from nonrenewable sources wane. So, Building A increases information content as nonrenewable material inputs decreases and the network pattern is gradually organized (AMI increases) with an increase of operational energy use. However, Building B goes through a complex circumstance and loss of the resource diversity balance. A decrease of a nonrenewable inflow seems adverse to increasing power and resilience during the early phases. It is largely because nutrients are obtained primarily from a single source, raw material (I_{N4} , Fig. 5.2 (a)) Therefore, it demonstrates that NZEB's huge investment to reduce fossil fuel use for operation results in the loss of resilience and adaptability to environmental change.

A loss of information content occurs when resource availability and a balance of the internal flow circulation collapse. In Building B's profile, replacement of electric appliances in the 16 year causes a drastic information loss. Emergy flows from maintenance of PV panels affect downturn in the 20th year, but its informational

impact is not greater than other mechanical and electric equipment. The greatest loss at the 45th year is mainly due to the overlap of replacement frequencies (walls, PV panels, lighting devices, etc.).

Fig. 5.3.2 (a) reveals discrepancy in the extensive system description using energy quantity (total throughput, TST) and the intensive description using information. Since nonrenewable energies and materials, unlike natural living systems, hold a large majority in the building system, reduction of inputs is generally expected to increase sustainability. At the first year, TST of $1.55E+18$ sej is inputted to Building B, whereas far less input ($0.58E+18$ sej) circulates in Building A. However, we notice that information of Building B (3.05 bits) is greater than that of Building A (3.01 bits). Not only that, it is also found that greater information content involves larger amount of TST or vice versa (e.g., from 9th to 15th year, 26th, 30th year, etc.). Therefore, in terms of the intensive system assessment, the causality of emergy reduction and sustainability may not be true and even appear contradictory. It also follows that information is able to evaluate the building performance that energy quantity cannot explain.

In this respect, AMI, a degree of network organization, often becomes a dominant descriptor of the system status. Even though total building information or complexity is large, if the AMI is too high, the system would become brittle, and its operation in a normal mode easily fails when a current environmental condition is perturbed. Fig. 5.3.2 (b) presents the variation of the building's organizational states. AMI tends to increase after 4~5 years for both buildings. Building B is subject to larger variability than Building A, and has greater AMI values on average. Nevertheless, it ends up with loss of resilience, because flow networking is structuralized mainly from the raw material source, and dwindled choice about source import drives the higher retention of the emergy circulation into an unfavorable direction to sustainability. AMI means a system's ability of effective nutrient delivery and, thus, pertains to efficiency. Despite the higher average, Building B's AMI becomes less in between over the course of building life, as if it loses efficiency. Building B's system network efficiency (AMI/H, the ratio of AMI and power), however, is distinctively greater than Building A.

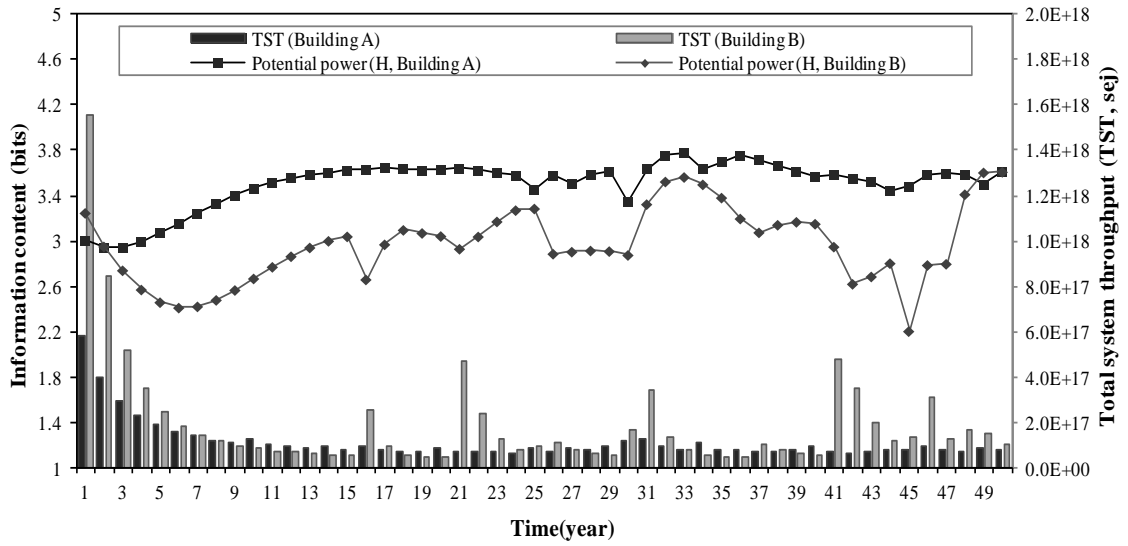

(a) Total system throughput (energy quantity) and information

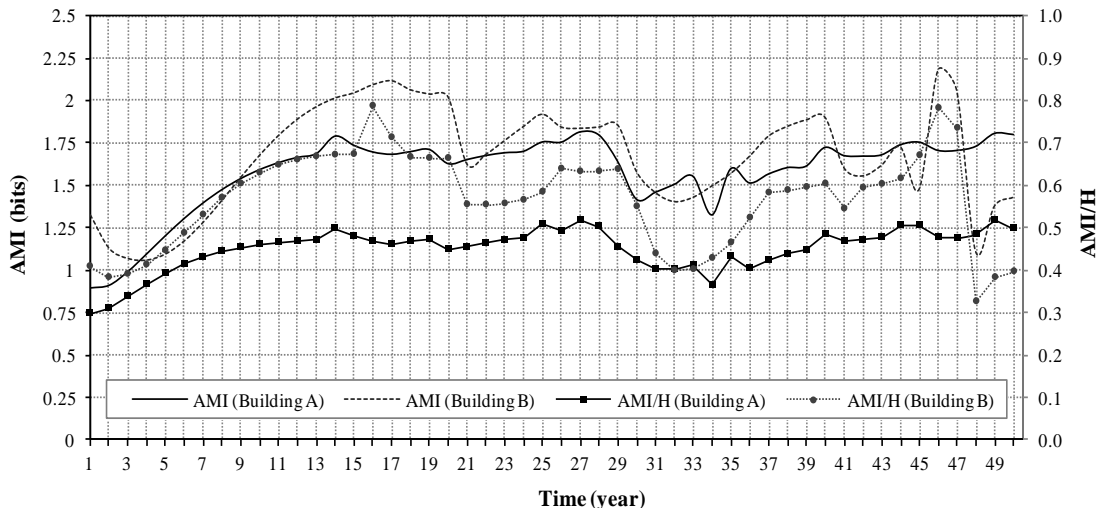

(b) AMI and network efficiency (AMI/H)

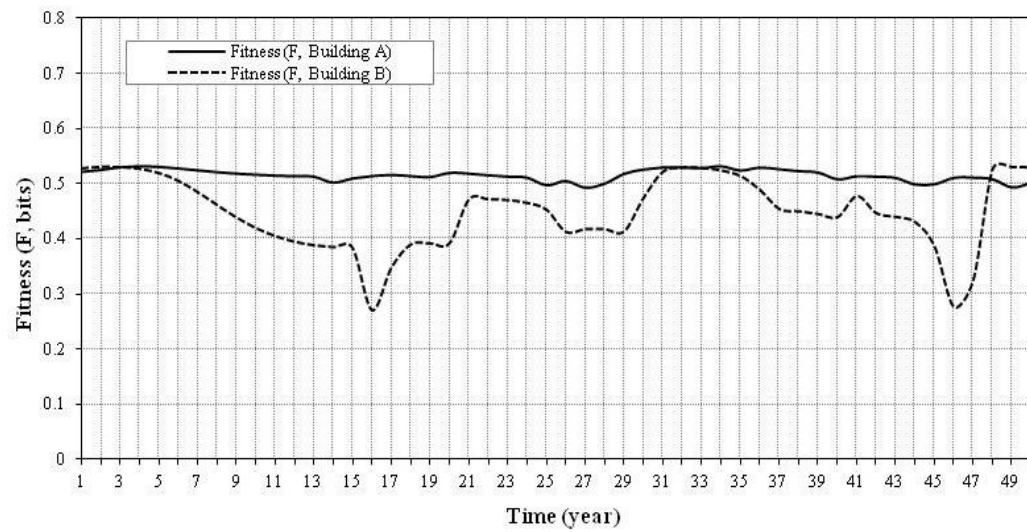

(c) Fitness

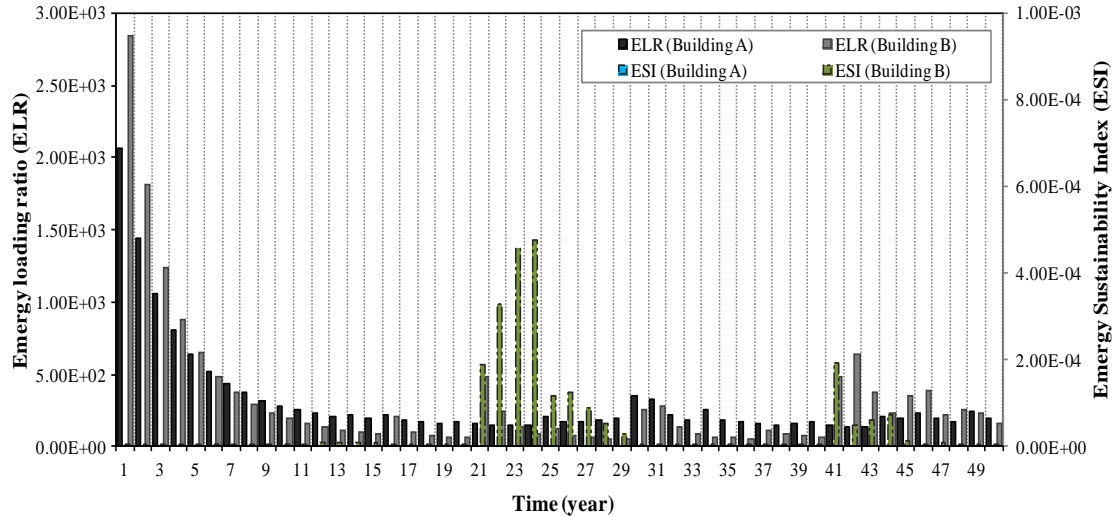

(d) Energy indices: Energy loading ratio (ELR) and energy sustainability index (ESI)

Fig. 5.3.2 Information profiles of the whole building over the entire building life (50years)

This finding clearly demonstrates the argument (presented in Chapter 3) that excessively increased system efficiency may cause the loss of power, resilience, and sustainability at the macroscopic level. It is also consistent with Ulanowicz's sustainability indicator, fitness, because the system of high potential power shows an increased fitness and adjusted system efficiency (AMI/H) which is closer to the optimum value, 0.37 (Fig. 5.3.2 (b) and (c); Section 3.2.2). The variations of energy loading ratio (ELR) in Fig. 5.3.2 (d) are similar to the TST changes in Fig. 5.3.2 (a). The NZEB has greater ELR during the early years due to a larger amount of nonrenewable construction materials, but the Building A's ELR becomes greater during the operation-dominated stages. This means that Building A is more degenerative in building operation. It is important to note that Building A outperforms the NZEB, even though the energy sustainability index (ESI) of the NZEB is markedly greater from 21th to 30th and 41th to 44th year. The potential power and fitness of Building A remain higher during that time. This contradiction reveals that an external (non-system-based) evaluation of building performance may lead to a biased diagnosis.

5.3.2 Whole system: Monthly

An investigation of the monthly variation of information content is very useful to

understand thermodynamic effects of system operation and seasonal changes of energy flow arrangement. The 33th year was selected to observe the monthly difference, for it is when TSTs of the test buildings are almost identical, and the whole building systems are stabilized in terms of adaptability (fitness).

In effect, information was measured every week for the analysis of high resolution. Informational indicators reveal that Building A is more sustainable during the year, because Building A's power is generally greater than Building B. Simulation measurements shows that average H, L, and AMI of Building A and B are 3.43 bits, 1.70 bits, and 1.73 bits and 3.18 bits, 1.59 bits, and 1.59 bits respectively (Fig. 5.3.3).

However, it is particularly interesting to find that Building A's information content is subject to more frequent fluctuation and that its trend is a downturn during the heating and cooling periods, whereas Building B's information is relatively constant during the winter. Also, Building A's resilience and power tend to be highest during the lowest conditioning periods (spring and autumn) but, conversely, Building B's information is minimized.

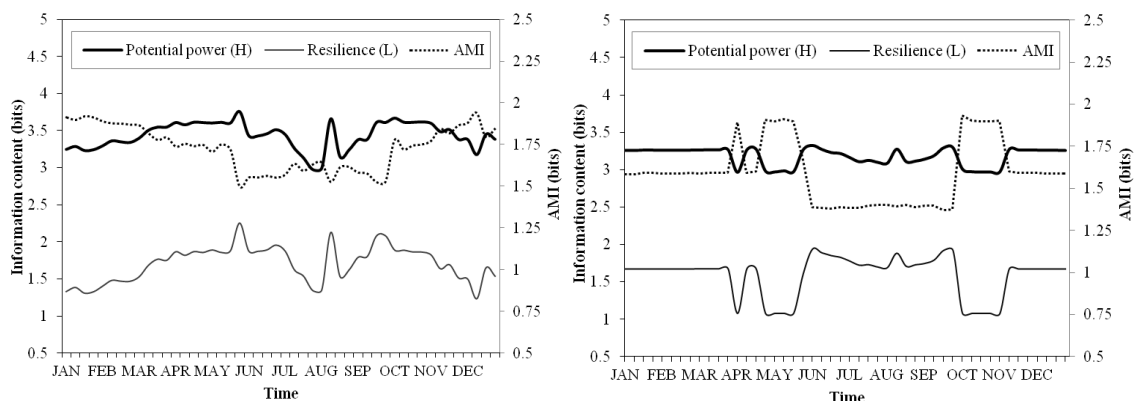

(a) Building A (baseline)

(b) Building B (NZEB)

Fig. 5.3.3 Information contents of Building A and B (monthly)

Building A's seasonal variation depends on the use of operational energy. If the mechanical equipment (gas furnace and air-conditioner) are turned off, system complexity increases, and the building carries greater useful information content in terms of environmental adaptation and robustness. From a quantitative view, Building B is expected to perform far better than the ordinary building (Building A). As substantiated in Fig. 5.3.4 (a), Building B actually circulates less energy for cooling and heating. However, the intensive investigation shows that Building B, during the

summer and winter, just catches up the Building A's information content or still does not reach that level. It is largely because NZEB is supposed to import raw materials and services (I_{N4} and I_{N5}), regardless of the season, in order to collect nonrenewable energies (solar and wind), and generate and store electricity. That is, consistent energy flows to the roof solar panels, battery, wire, and associated electric devices prevent Building B from accumulating information.

Moreover, NZEB's energy reduction sacrifices the system's organizational ability. Fig. 5.3.4 (b) shows Building B's AMI is less than Building A during the heating and cooling season. So, it demonstrates that Building B's flow networking, despite the decreased TST, is disadvantageous to organizing useful energy into a sustainable direction. Meanwhile, as the building behaves over the life time, throughout the year, the high-power system attempts to operate at an intermediate level of efficiency. When external conditions are favorable, Building A's efficiency (AMI/H) comes closer to the optimal value (0.37) at a steady state (Niches in May, August, and December are due to the holiday schedule of building operation).

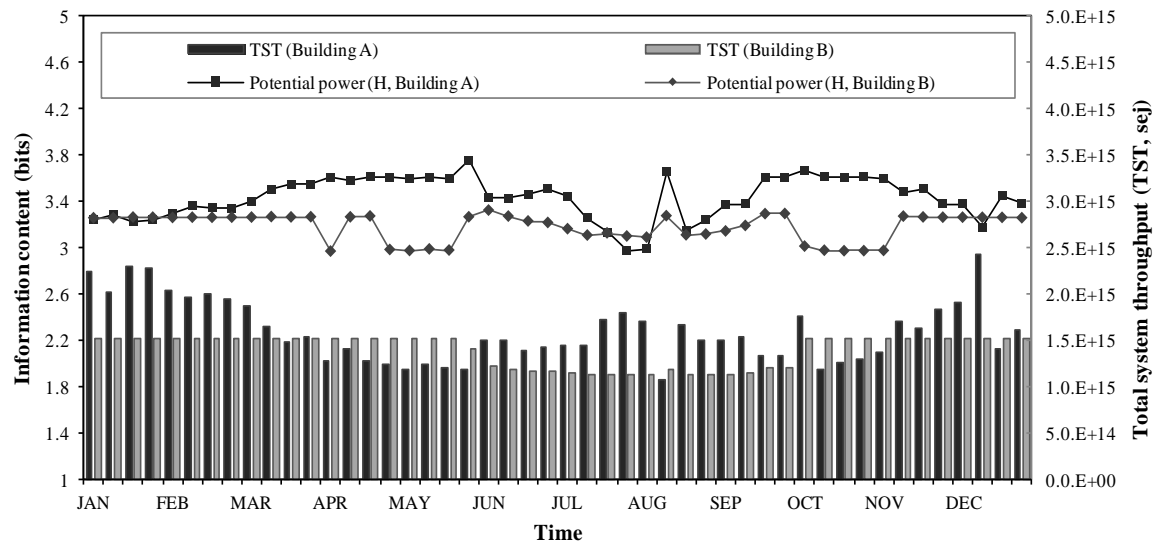

(a) Total system throughput (energy quantity) and information (the variation of Building B's TST looks relatively uniform because materials inputs to mechanical equipment are constant regardless of seasonal change.)

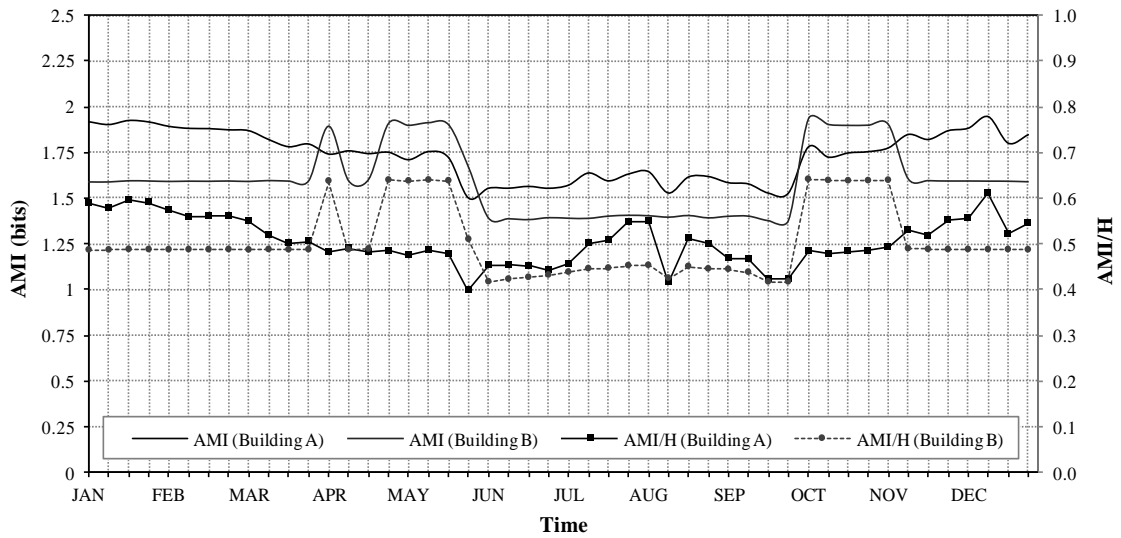

(b) AMI and network efficiency (AMI/H)

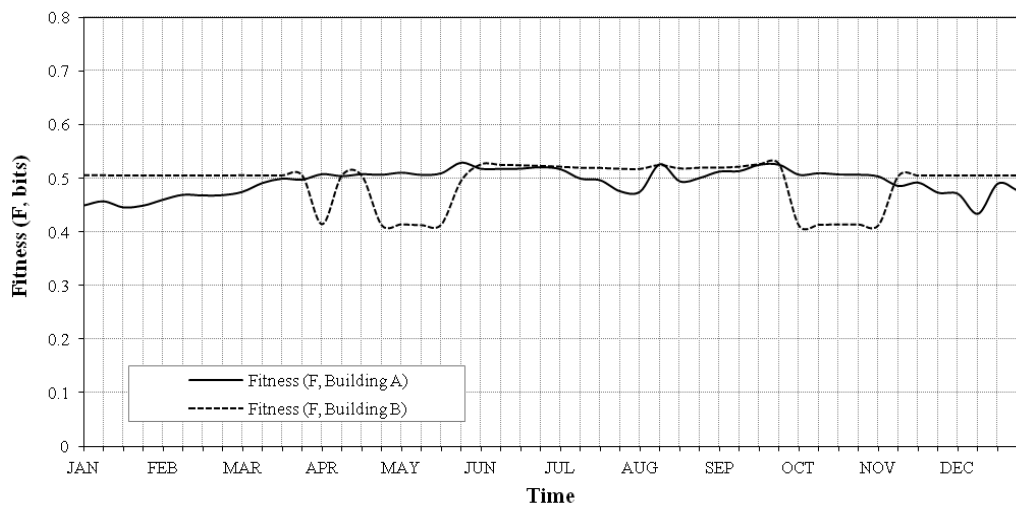

(c) Fitness

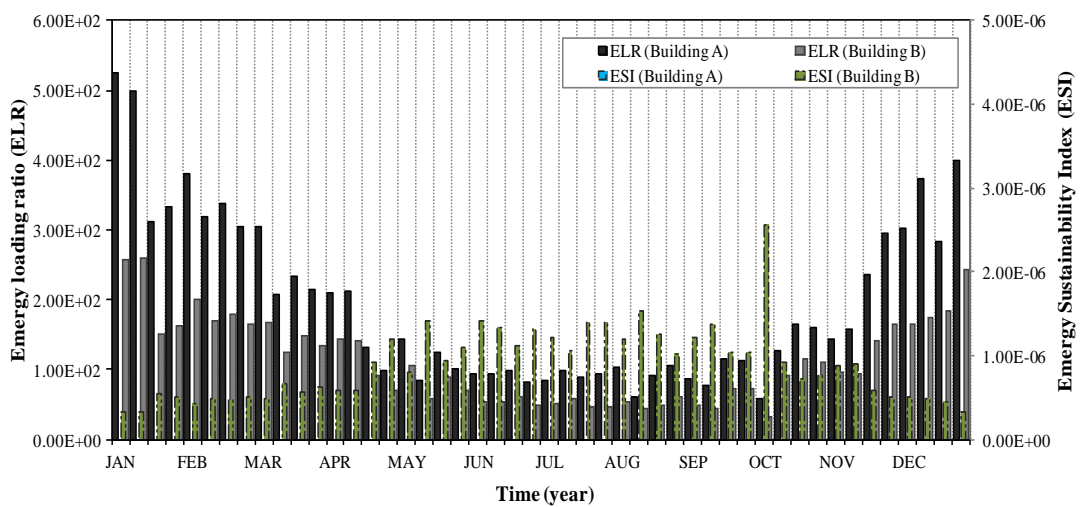

(d) Energy indices: Energy loading ratio (ELR) and energy sustainability index (ESI)

Fig. 5.3.4 Monthly information profiles of the whole building

Resilience and fitness profiles exhibit that NZEB is not good at environmental adaptability, especially during the non-conditioning periods, because highly thick insulation and a great deal of machines to control thermal comfort efficiently perform unfittingly, if the outside climate is favorable. On the other hand, energy-based indicators in Fig. 5.3.4 (d) show that Building A is less sustainable (generative) than the NZEB during the operation-dominated stages, because the ELRs of Building A are greater and the ESIs are zero. Nevertheless, according to the information measurement, Building A can be more adaptable and have greater power (Fig. 5.3.4). This result confirms that the building's internal organization of inputs and outputs is significant for sustainability and, thus, we may have a biased diagnosis of building performance unless examining the work of self-organization.

5.4 Information of building form and human behavior

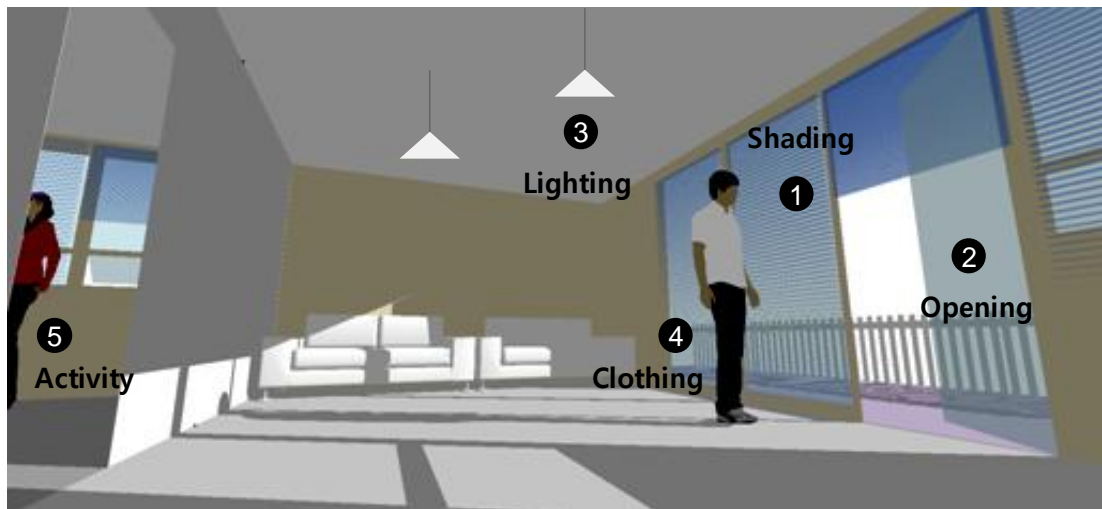

Fig. 5.4.1 Emulation of human behavior in Building A at the ecosystem level

To verify the hypothesis that the building form takes on the greatest responsibility to achieve sustainability, this section attempts to evaluate the information content of the building form and human (occupant) behavior associated with formal mutation. Whether or not the empower principle is in accordance with the examination of the building form's resilience is also a main goal of this experiment. Regarding the evaluation of a human dominated system, the primary concern is to demonstrate Chapter 3's argument that a building system of high resilience and fitness is the

system in which the feedback of occupant works the most effectively. It is because the occupant's activity is the most dynamic factor and utilizes a quasi-renewable source (i.e., genetic information) for the mechanic system control and climatic adaptation of the building form.

To this end, experimentation refers to the BEmA for the building envelope, and divides the baseline into four different cases: (i) Building A-as-is (full mechanical air-conditioning and fixed thermostat set point), (ii) human behavior-dominated control, (iii) behavioral management with enriched insulation (following the Passive House code), and (iiii) Building B-as-is.

5.4.1 Effect of climate-adapted behavior to energy flow networking and information

For bioclimatic adaptation in the course of the envelope's climate modification, human engagement can strengthen the feedback flow (Chapter 3 Fig) and rearrange the building form's energy flow networking, as the genetic information controls living systems functioning, not directly through information but through its enclosure (Schneider and Kay, 1994). Also, as demonstrated in Chapter 3, human information flows play a critical role in increasing system resilience and robustness, because the feedback loop eventually makes the form self-organize to resist to external perturbation (Meadow, 2008). In this thermodynamic mechanism, adding or restoring useful information is a powerful intervention of system management to achieve sustainability, for human information is most immediately available to restructuring system functions (Meadow, 2008). Smart human activities can apparently buffer an extreme effect of climate conditions in an energetically easier and cheaper way. However, what is still in question is whether adaptive behavior always contributes more to sustainability (and resilience) than so-called high-performance buildings form (e.g. NZEB) or vice versa. In this regard, for effective living system-inspired sustainable design and operation control, it is necessary to elucidate the threshold of building information content required to maintain system stability, so it thus informs a leverage point of system management. By so doing, we can account for, with informational indices, the correlation of the building form and behavior and priority of sustainable design/evaluation criteria.

In short, human behavior is significant to measuring building performance at the

macroscopic level, particularly in that (1) the occupant's activity is an ecosystem component in accordance with formal variation (Chapter 3 and 4), and (2) it is important to identify how impactful the local change is for thermodynamic adaptation of building performance in the global environment. Human information content, at the global system level, can be measured by investigating a source-sink pattern of energy flow organization, which originates from a transient interplay between the building form (envelope) and occupant behavior. Building information change is obtained by comparing normal building operation with a fixed thermostat set point (baseline) and adaptive building use (austere operation).

5.4.2 Inputs and assumptions of model setup for behavior emulation

Behavior and bodily recognition of thermal comfort influences the immediate daily operation of the mechanical equipment such as ventilation system control and thermostat setting that is closely associated with the whole building energy consumption. Van Raaij and Verhallen (1983) identify the consequences of occupant's habit or sensitivity and physiological characteristics that can explain up to 26% of heating demand. Iwashita and Akasaka (1997) report that people account for 87% of the total air change rate of a building. Van Raaij and Verhallen (1983) also categorize types of human behaviors in residential building energy use largely in three parts: purchase-, usage-, and maintenance-related behavior. The purchase- and maintenance-related behaviors are subject to the efficiency of machinery and equipment, while the usage-related behaviors refer to thermal comfort-conscious occupants' activity patterns.

Therefore, this study categorizes major occupant behavior types and controllable objects of building envelope loads based on previous studies (Polinder et al., 2013; Lee and Malkawi, 2014), which aims to explore how they contribute to the building system's self-organizing work. Table 5.4.1 lists target objects of the behavioral control that are used for this experiment.

Table 5.4.1 Building objects of physical management and factors in thermal comfort

<i>Object</i>	<i>Description</i>	<i>Focal environmental factors</i>
Shading devices	Operation of interior/exterior screen	Indoor daylight and glare, window solar heat gain, transmitted solar heat
Operable windows and doors	Natural ventilation to refresh or cool the air	Internal heat gain, indoor airflow, humidity level
Lighting equipment	Artificial sources of visible illumination	Solar radiation and indoor illuminance
Thermostat Equipment use	Operation of heating/cooling system	Indoor air temperature, people occupancy, clothing levels

The occupant's shading control can change the transparency and shape of building envelope, and user operation of the envelope fenestration also strongly affects the building's formal status. Lighting control and thermostat setting are necessarily coupled with the operation of such physical elements. To test an immediate environmental impact, EnergyPlus and Radiance were used to calculate energy usage and indoor illuminance. By coupling the physical objects with environmental factors in Table 5.4.1, Table 5.4.2 presents specific simulation targets, associated environmental loads, and EnergyPlus control objects and parametric variables for the behavior simulation.

Table 5.4.2 Simulation targets and parameters

<i>Target</i>	<i>Load</i>	<i>Control object (EnergyPlus)</i>	<i>Behavior input (parameter)</i>
Lighting	Lighting	Light Intensity	Lighting schedule
Daylight	Internal Gains	Daylighting:Controls Dimming control type	Illumination Setpoint Schedule
Interior blinds	Cooling	WindowProperty:ShadingControl Shading control type	Control Setpoint Schedule
Window operation		WindowProperty:AirflowControl ZoneVentilation:Wind/StackOpenArea	Air flow Schedule
Clothing levels	Heating	Clothing Insulation Level	Clothing Insulation Schedule
Metabolic rates	Cooling	People Occupancy/Activity Level	Activity Level Schedule
Air-conditioning equipment		ZoneControl:Thermostat ThermostatSetpoint/DualSetpoint	Setpoint Schedule

From Wiener and Shannon's mathematical definitions, human information content involved in a system can correspond to the number of decision-making that an observer makes to manage system phenomena. Nevertheless, even though a system boundary defines thresholds and conditions of behaviors, human actions are essentially spontaneous. Any unscripted circumstance other than climate condition can affect behavioral decisions. However, since this study focuses on thermodynamic aspects and ecological robustness of human-dominated building control, occupant's

energy-conscious decisions about the management of indoor thermal comfort is of the primary concern. Thus, the following decision-making flow chart was made to set up an energy simulation model (Fig.5.4.2), because behavior-based controls can be roughly emulated to the sensory energy management.

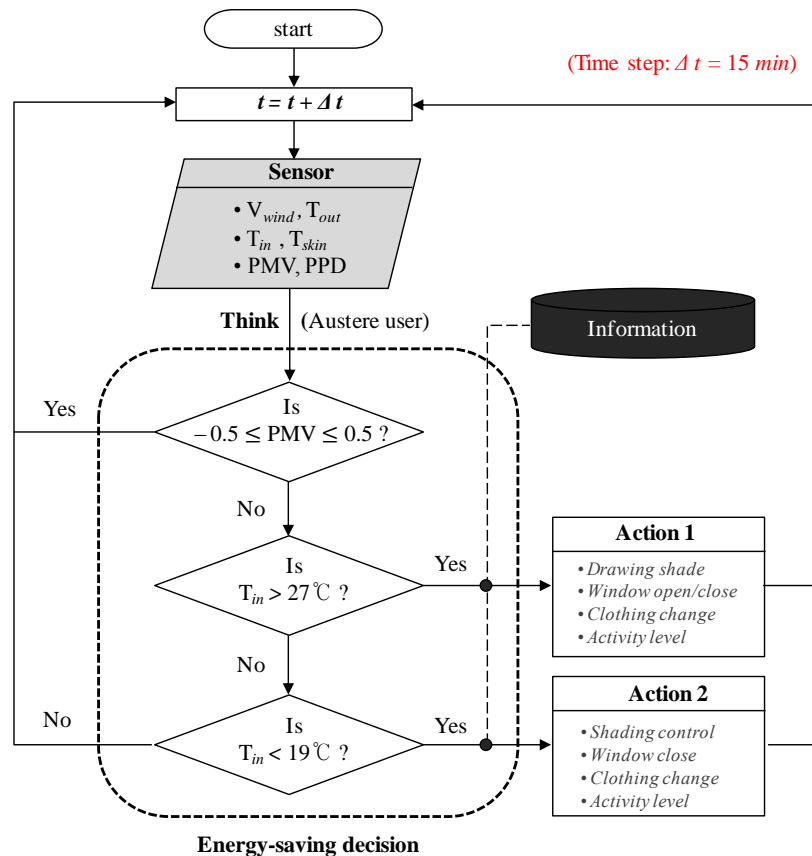

Fig. 5.4.2 Decision-making chart (Main loop)

To construct the simulation model, it was assumed that building users are climate-conscious, adaptive, object-oriented, fully accessible to the enclosure, and well-informed to make intelligent energy-saving decisions unless thermal satisfaction is hindered. Occupants make an operational decision every 15 minutes according to a bodily thermal sensation and indoor environmental status measured from the sensor. Thermal comfort, however, is difficult to quantify because it is highly subjective and contingent on numerous factors (air and radiant temperature, air speed, humidity, metabolic rates, clothing levels, etc.). So, in order to indicate the comfort level quantitatively, six environmental indices are measured through a sensor: outside wind velocity (V_{wind}), indoor zone and outdoor temperature (T_{in} and T_{out}), mean skin

temperature (T_{skin}), predicted mean vote (PMV), and Predicted percentage of dissatisfied index (PPD). Each of which indicates assurance of thermal comfort within a certain numeric range and scale. The main loop of the emulation of behavioral adaptation has the users check PMV first, because PMV (and PPD) are the most suitable for self-reported perceptions of an occupancy condition. The ASHRAE-55 2010 Standard recommends that an acceptable PMV value ranges from -0.5 to +0.5. If a measured PMV index is between the numbers, the occupants do not act, and would check next (almost simultaneously) if zone air temperature is within the acceptable range (ASHRAE 55 recommendation is approximately between 19°C and 27°C). If the PMV and PPD meets requirement, user's decision-making occurs only one time regardless of temperature and, thus, information becomes zero. However, the temperature is off the points, information about adaptive behaviors is utilized and becomes measurable. Since these three decision-makings occur four times an hour, the occupant decides 288 times per day. Then, maximum information content, theoretical accumulation for a day, is 8.17 bits. However, note that information triggering effective actions to the final energy reduction is only counted and, thus, measurable values are necessarily less than the maximum.

Fig. 5.4.3 and 5.4.4 depict the sub simulation routines of adaptive behaviors (*Action 1* and *Action 2*). If the indoor environmental condition does not satisfy the minimum requirements, it was assumed that the occupants would react to recover comfort, while minimizing HVAC use. In effect, the nominal temperature criteria assumes the sedentary activity and average clothing level, yet the occupants can adjust activities and clothing according to the indoor condition. Therefore, a new comfort range using sensory temperature is suggested for the decision-making charts. Generally, a coarse model of comfort temperature presents comfort air temperature (Attia et al., 2015) as,

$$T_c^{ASHRAE\ 55} = 0.31T_o + 17.8$$

where T_c is comfort temperature, and T_o is the monthly mean of the outdoor dry-bulb temperature

However, thermal satisfaction is more accurately assessed by an occupant's individual

thermodynamic state. In this experiment, comfortable clothing temperature is calculated using the following equation:

$$\dot{Q}_{sens} = \frac{A_{clo}(T_{skin} - T_{in})}{R_{clo} + 1/h_{comb}}$$

where \dot{Q}_{sens} is bodily heat transfer (loss) in sensible forms, A_{clo} is the clothing surface area of a human body, R_{clo} is the unit thermal resistance of clothing, and h_{comb} is the heat transfer coefficient incorporating radiation and convection between clothing and ambient air.

In general, at a state of thermal comfort, T_{skin} is about 33°C (A human body does not feel discomfort at 32~35°C), A_{clo} is 1.8m², and h_{comb} is 8.7 W/m²°C (Çengel et al., 2011). R_{clo} is represented in clothing insulation level (clo). According to the ASHRAE 55-92, 1 clo is 0.155 m²°C/W. Introducing these general values, heat equivalency between the inside and outside of the clothing gives,

$$\frac{1.8(33 - T_{skin})}{0.155 clo + 0.115} = \frac{1.8(T_{skin} - T_{in})}{0.115}$$

Then it becomes,

$$T_{skin} = \frac{(0.155clo + 0.115)T_{in} + 3.795}{0.155clo + 0.23}$$

Hence, if $T_{in} \leq 27^\circ\text{C}$, then $T_{clo,27} \leq (4.185clo + 6.9)/(0.155clo + 0.23)$, else if $T_{in} \geq 19^\circ\text{C}$, then $T_{clo,19} \geq (2.945clo + 5.98)/(0.155clo + 0.23)$, where $T_{clo,27}$ and $T_{clo,19}$ are thermostat set points at 19°C and 27°C respectively. For these formula, the clothing level is a dominant parameter and other variables such as humidity and indoor air speed whose values are strongly affected by window operation, are also influential. Even if this study assumes that changes of behavioral pattern (changing clothes and activities) are the last resort, however, for the behaviors, there is no priority among one another. That is, we cannot describe its status deterministically. So, probabilistic models are used for spontaneous behavioral inputs. First, window opening can be modeled as follows (Rijal et al., 2007):

$$p_w = \frac{e^{0.157T_{out}-2.92}}{1 + e^{0.157T_{out}-2.92}}$$

Hence, ventilation rate can be estimated by the envelope surface area for air flows such that,

$$A_a = p_w A_w$$

where p_w denotes window opening probability, A_a is the opened area of window, and A_w is total operable window area.

Parameters of the probability functions of clothing level and other controlling inputs (lighting, appliance use, and body heat from activity) are as shown in Table 5.4.3. From literature, it was assumed that clothing insulation approximates normal distribution and other parameters would follow triangular distribution.

Table 5.4.3 Parameters of probability distributions of other simulation factors

Clothing insulation level (<i>clo</i>) ^a			
		μ	σ
Summer: Day		0.32	0.08
Summer: Night		0.15	0.05
Winter: Day		0.9	0.09
Winter: Night		1.38	0.11
Other parameters ^b			
	Base	Min.	Max.
Lighting power: General (W/m ²)	13	11	15
Lighting power: Intense(W/m ²)	15	11	19
Appliance density (W/m ²)	15	12	22
Occupant metabolic rate (W)	80	70	130

a. Oğulata, 2007 b. Mcdonald ,2002; Heo, 2012.

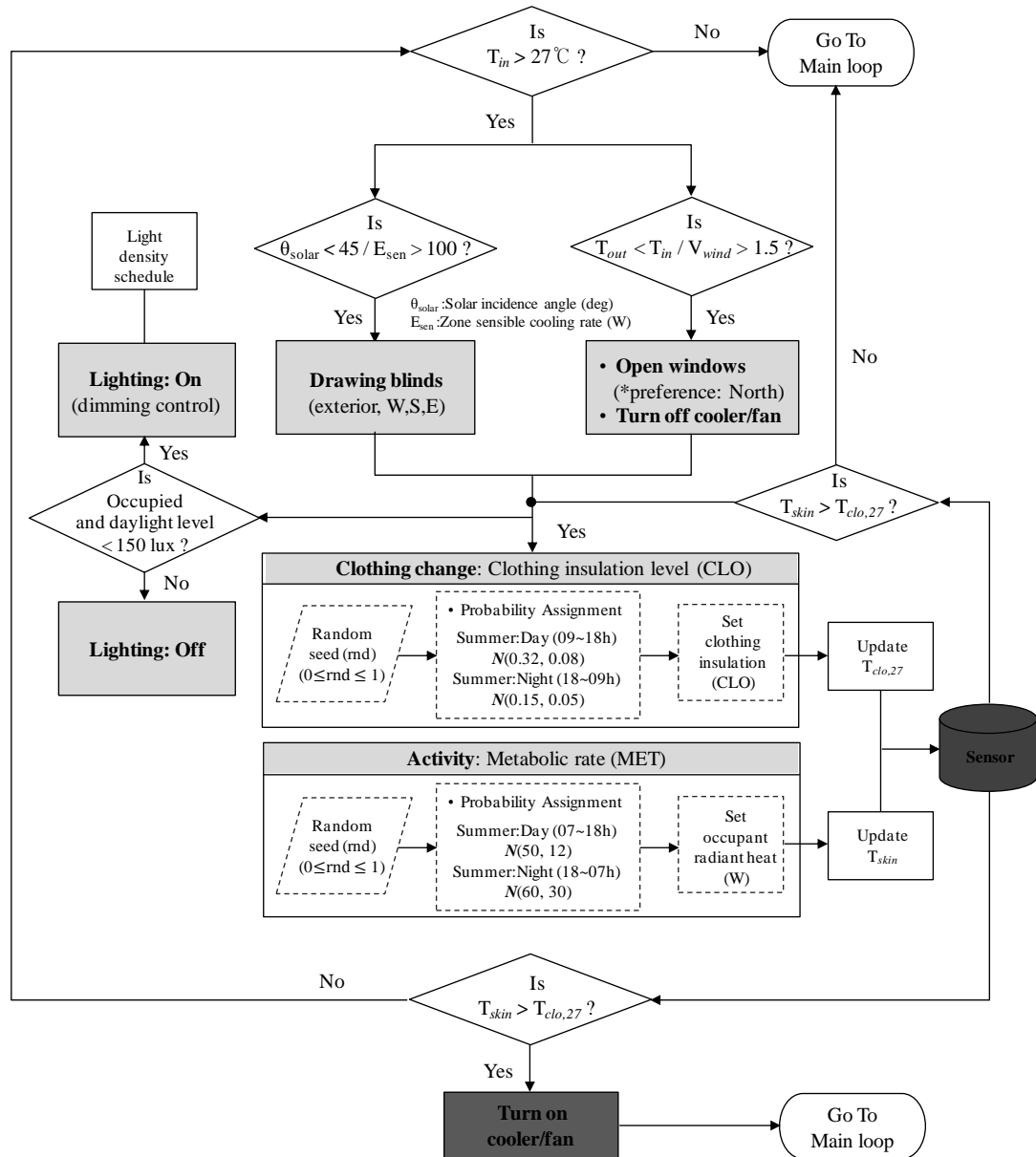

Fig. 5.4.3 Decision-making chart (Sub loop: Cooling)

Fig. 5.4.3 is a decision-making chart when cooling load is dominant. Adaptive control of building envelope and the final action is set thermostat temperature. The user checks slate angle of blinds and solar radiance (indoor cooling rate, E_{sen}). If wind is available (greater than 1.5 m/s; breeze), the user can determine to open or close windows to lower zone temperature. Changing clothes and activities is the next resolution, if the user cannot find satisfaction. Similarly, during heating days, occupants adapt themselves by changing lighting level and activities. Updated user information and a degree of satisfaction updated when exiting the loops (Fig. 5.4.4). Energy simulation results show that human-dominated control reduces 61% of energy

use, from 67.35 to 26.24 GJ/yr (Fig. 5.4.5 (a)). Though lighting use slightly decreased from 2.04 to 1.58 GJ/yr, about 86% cutback of cooling is considerable (12.42 to 1.75 GJ/yr). Heating energy use still remains high in spite of 56.7% reduction, but it is noticeable that the improvement of insulation to the Building B's level removed heating demand (Glazing was not changed. U-values are 0.08W/m²K for roof, 0.1W/m²K for walls; 0.09W/m²K for ground floor, which are above or equal to the Passive House Standard.). As a result, the baseline case (Building A) ends up being a nearly NZEB by achieving about 92% cutback, only by involving human intervention about the building form.

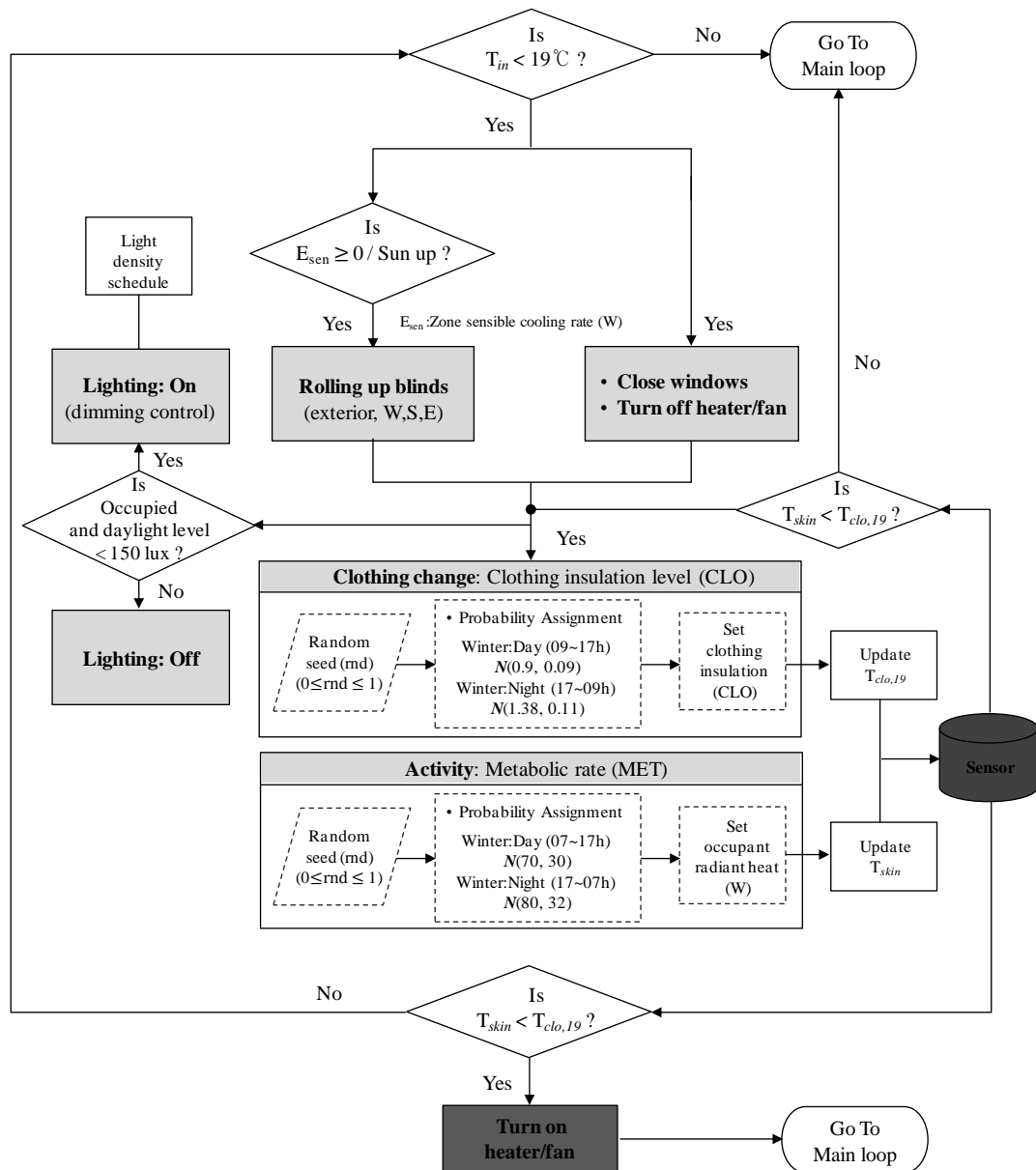
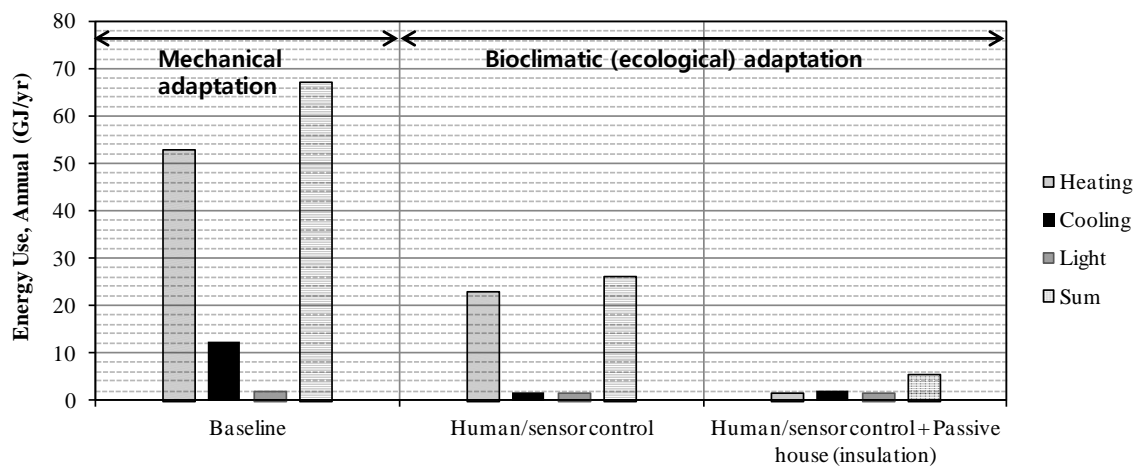

Fig. 5.4.4 Decision-making chart (Sub loop: Heating)

We can term the baseline operation as mechanical adaptation, and the behavior-based sensory control as bioclimatic or eco-systemic adaptation, because human behavior (a component of building ecosystem) is a key agent in the modification of environmental conditions and the self-organization of the system (form).

The difference between mechanical and bioclimatic adaptation is revealed in temperature profiles. For the baseline, temperature variation occurs within a small range, since set point of the HVAC system is constant throughout the year. But human involvement extends the range with flexibility, while providing thermal comfort (Fig. 5.4.5 (b) ~ (e)).



(a) Energy reduction from human behavioral management

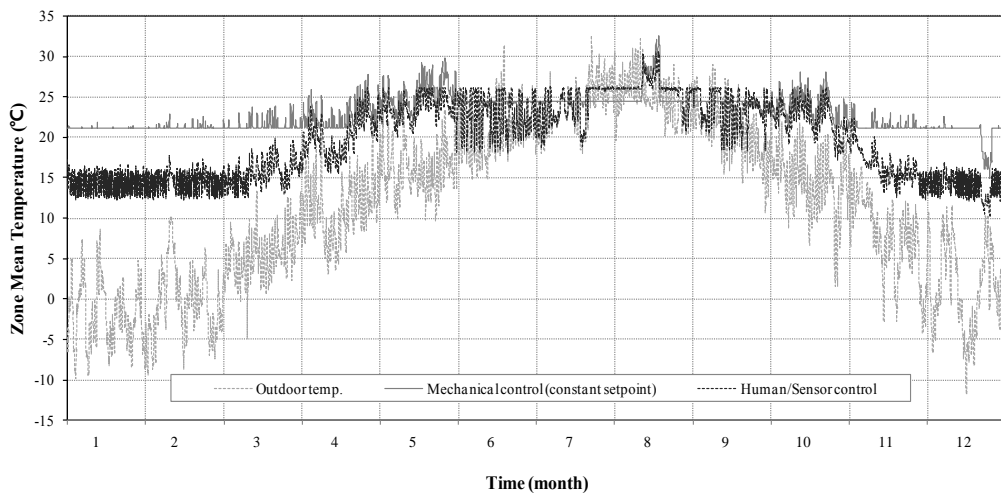

(b) Zone air temperature profile

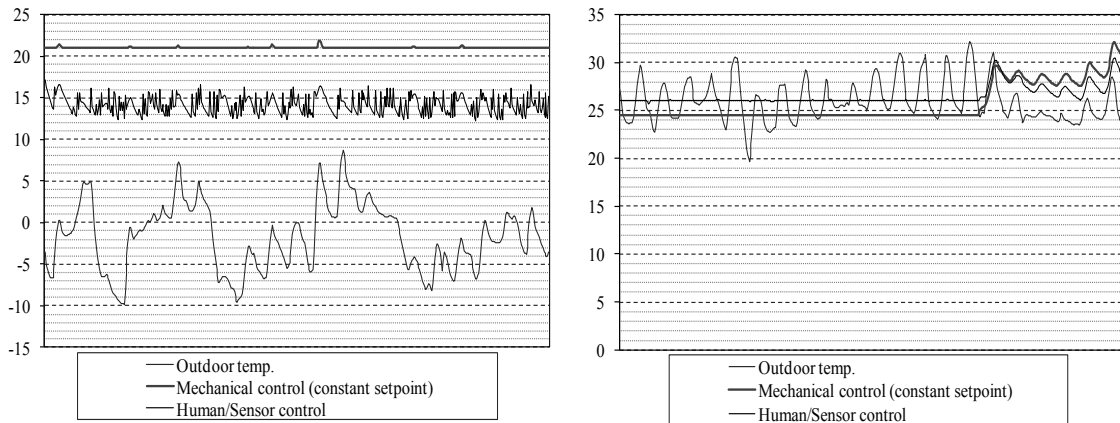

(d) Air temperature: December, 21 (± 1 day) (e) Air temperature: June, 21 (± 1 day)

Fig. 5.4.5 Results of human behavior simulation

5.4.3 Simulation results: Information of building form and adaptive behavior

From the energy syntheses of envelopes in Section 5.2 and energy simulation of human behaviors (Section 5.4.2), information content of each type of building form is evaluated. This experiment is important to discuss environmental performance of formal elements (walls, roof, floors, and windows) and its architectural organization in built form. It will eventually enable us to clarify why we should engage the ecological attributes of developed systems (greater internalization, recycling, feedback, information, etc.) in decision-making processes of the environmental building design, construction, and management, and, furthermore, design quality.

Before analyzing information, it is very important to understand that, once we establish a form, each compartment of the envelope functions differently, since it is exposed to different environmental conditions as well as architectural needs. To be specific, different intensity and direction of solar radiation, daylight, and wind at the position of a building form element make the element react to the environment in a different manner. A ground floor generally needs thicker insulation boards and more structural material than a vertical wall, which triggers greater resource import. That is, each part of the formal components consistently works to distribute and assemble environmental resources of different quality, simultaneously self-organizing the building form as a whole and, at last, that ends up making the building a form of self-organization. These examples provide a solid rationale for an understanding of the building form as an intracompartmental system and an intensive systemic approach to

the form analysis. In this experiment, four design cases and three different time frames (year, month, and hour) set in the observation of information changes are employed to verify the hypotheses and arguments of building sustainability, by addressing different domains and factors of the building's self-organizing phenomena.

5.4.3.1 Envelope: Annual (life cycle analysis)

Note again that this experiment compares the four test cases: (1) Case 1: the baseline (envelope of Building A-as-is); (2) Case 2: behavior-based control of Building A's envelope; (3) Case 3: the second case with high-performance insulation; (4) Case 4: the envelope of Building B (NZEB).

Fig. 5.4.6 presents profiles of the information indices over the entire building life. Overall performance of each system is revealed with mean values of the indices. For Case 1 (baseline), H, L, and AMI per quantum are 3.85 bits, 2.52 bits, and 1.33 bits. Human information inputs increase potential power (system complexity) to 4.01 bits and 3.95 bits for Case 2 and 3 respectively. Case 4 shows the lowest power, 3.57 bits, and the resilience of 1.99 bits is also less than other three cases (2.52 bits, 2.54 bits, and 2.58 bits). AMI rankings are the other way around. Case 4 is the greatest (1.58 bits) and Case 1 is the least.

It is interesting to find that every index exhibits a certain cyclic pattern, but different frequencies and amplitudes in the information change profiles have been identified for the cases, since energy flows are subject to various operation/maintenance schedules. Case 4 (NZEB) has a number of sharp downturns due to a more varied assemblage of complicated building elements that supports high-efficient mechanical operation. In Case 2 and 3, the frequency appears shortened as time elapses. The first peak point is found at the 30th year, but, next, at the 43th year peak power and resilience (Fig. 5.4.6). It is also noticeable that greatest amount of information accumulation at the 30th year is in common for all cases. It is largely because life spans of general nonrenewable materials and service inputs (e.g., glazing and HVAC systems), overlap around that time for the Building A and B.

After a cycle, variation patterns are renewed with slightly weakened amplitude. So, we can expect that formal information becomes alleviated gradually as the form goes through thermodynamic degradation. During the period of one cycle, it is very important to notice that Case 2 and 3 show greater coherency in the gradual increase

of system power (H) and AMI, whereas variation trends of AMI are ill-suited to that of H in Case 1 and 4 (we even find an inverse relation in Case 4). This demonstrates that the consideration of adaptive human behavior coupled with dynamic formal variation allows the building's thermodynamic functioning to be likened to the Eugene Odum's observation of ecosystems—ecosystems accumulate greater information, complexity, power, and organization as they develop (Odum, 1969). In other word, with little mechanical operation, building life cycle would be better characterized with the living system's developmental and evolutionary rhythm. It follows that what we have to think about how environmental building design makes competitive and consistent rearrangements of emergy fluxes towards “metabolic” system development.

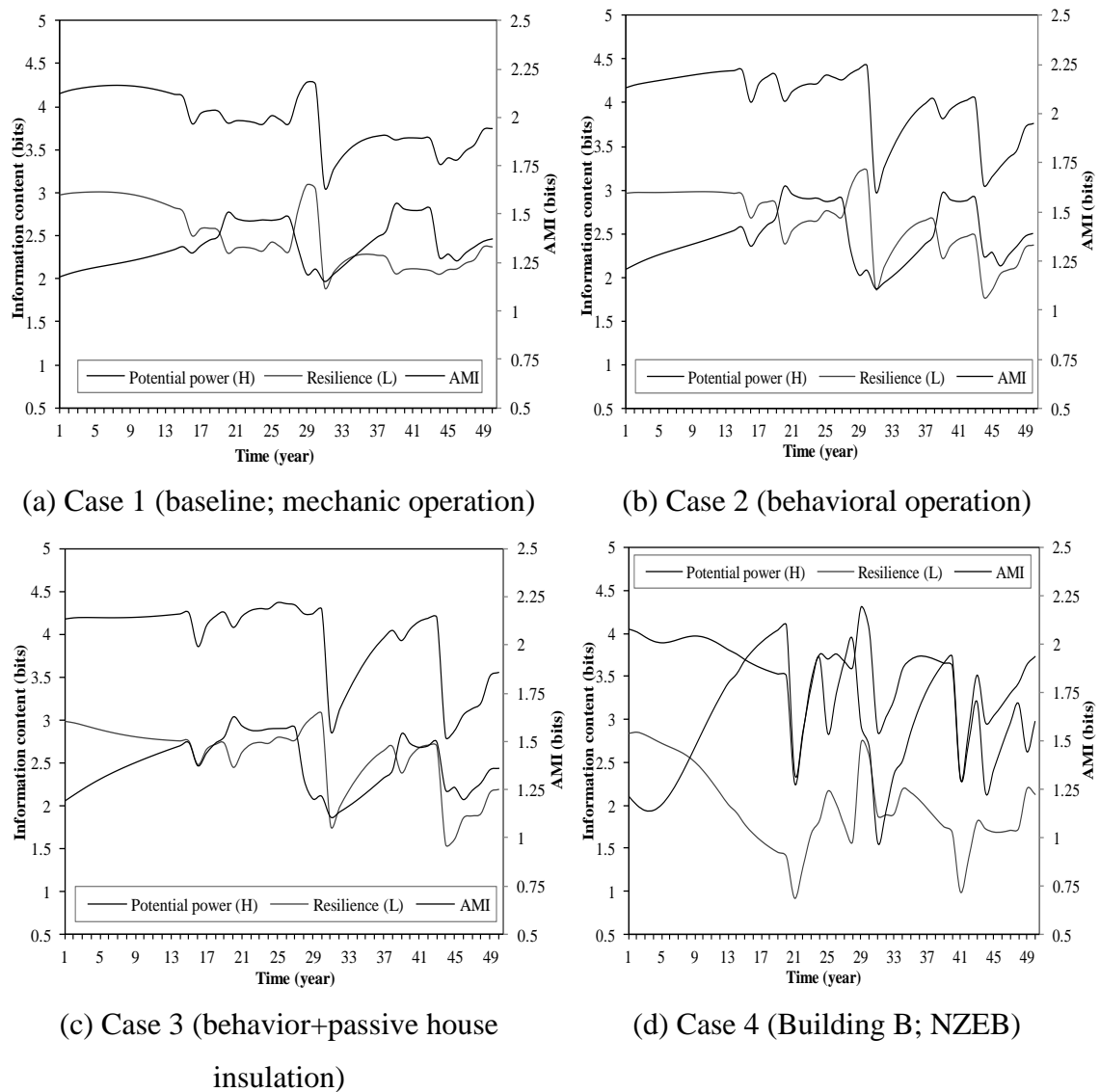
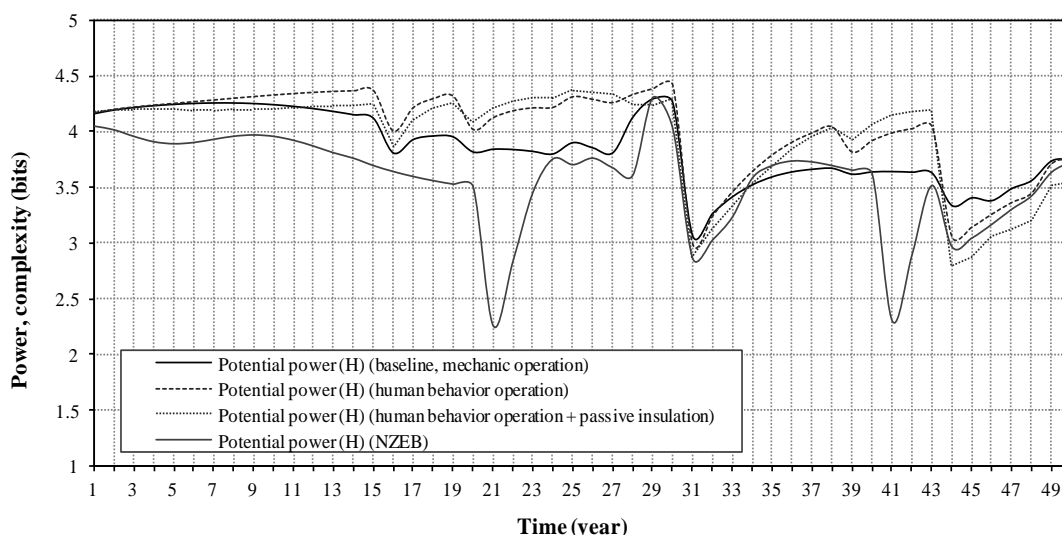

Fig. 5.4.6 Information content of the case study forms (yearly)

On the other hand, building form's information profiles are quite different from the whole building system due to different system networking and participants. For example, at around 37th year, Building B shows turndown, while information of the whole system is still on the increase.

Fig. 5.4.7 (a) compares the potential power of each case. Due to the greatest influence from building materials for construction, the power is similar to each other at the first year (4.0~4.2 bits). Nevertheless, looking at Case 2 and 3, reduced fossil fuel use has an impact as the materials are degraded, and the form becomes more sensitive to operational states. It clearly reveals that adaptive behaviors in energy use make a critical contribution to an increase of information content and sustainability.

In terms of environmental adaptability (Fig. 5.4.7 (b)), Case 1, 2, and 3 do not show distinctive difference, but comparison of resilience (Fig. 5.4.7 (c)) shows that human intervention gives the building form more flexibility in flow networking with robustness. However, it also shows that, unlike the energy simulation results (Fig. 5.4.5 (a)), human behaviors with intensified insulation may not be more effective for sustainability than behavioral operation only, since the resilience of Case 3 is not always greater than Case 2 due to the use of environmentally expensive nonrenewable materials for additional energy reduction.



(a) Potential power

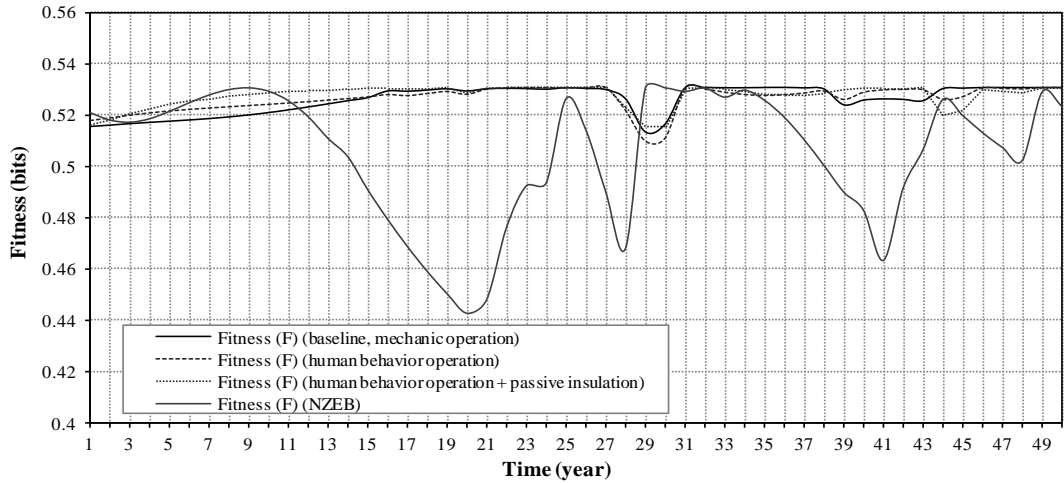

(b) Fitness profiles

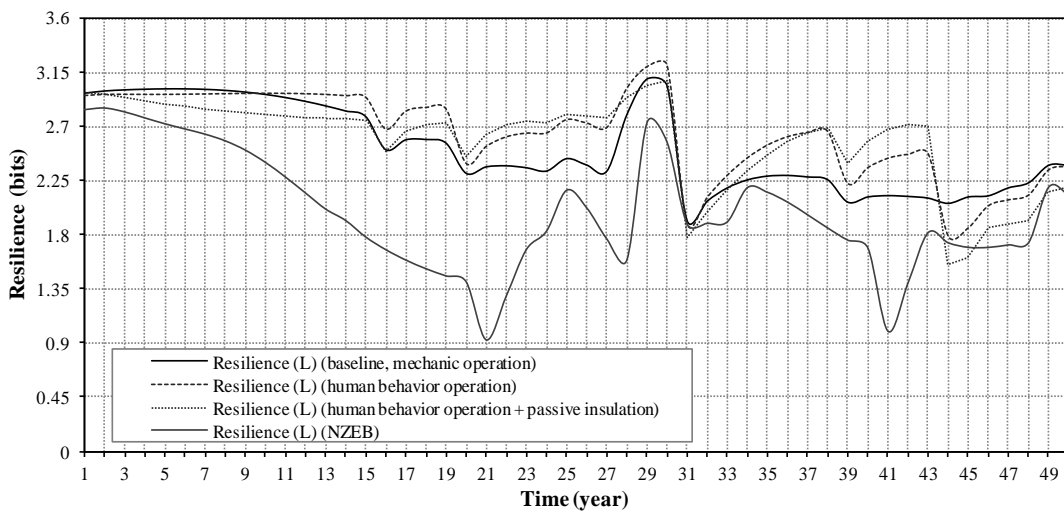

(c) Resilience profiles

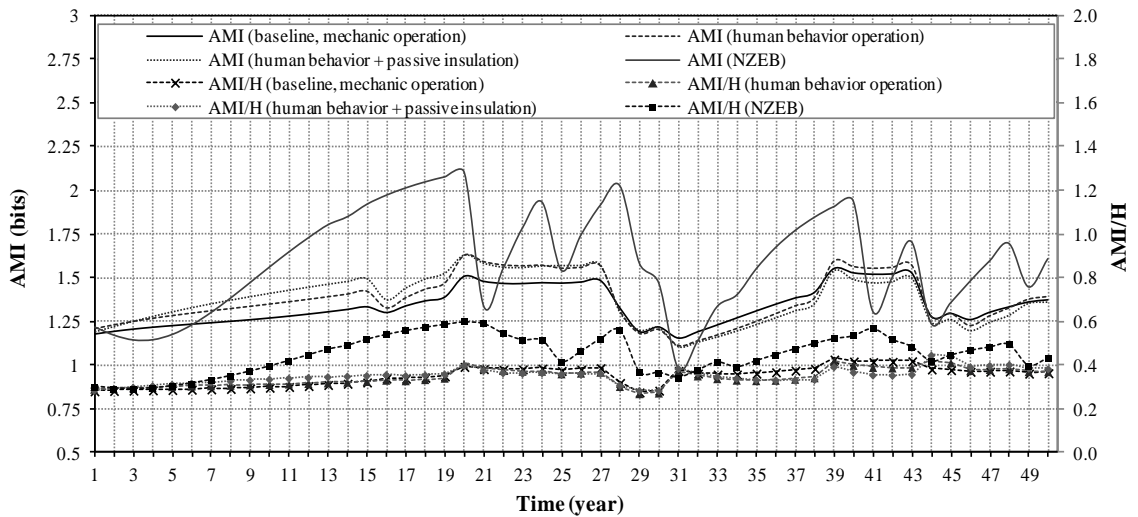

(d) AMI and network efficiency (AMI/H)

Fig. 5.4.7 Information profiles of the case study forms (yearly)

Case 3 that achieves nearly zero energy use is far more resilient than Case 4. So, Fig. 5.4.7 (b) and (c) demonstrate that biological adaptation (i.e., occupant's activity based building control) is a more sustainable way to reduce operational energy use than the current definition of NZEB.

Fig. 5.4.7 (d) presents a degree of flow association (AMI) and efficiency (AMI/H). AMI profiles of Building A's alternatives appears quite similar, so we can argue that operational energy is insignificant to the AMI values in the yearly variation. Greater values and frequent fluctuations of AMI, in Case 4, show NZEB has a more effective network structure to circulate energy sources, but it becomes weaker at any perturbation.

AMI is basically well-suited to identifying autocatalytic networking (e.g., recycling of ecosystem nutrients). But AMI could also be augmented by other causes: (i) compartmentalization, (ii) specialization (reduction of untoward flows), and (iii) internalization (positive feedback loop or an increased resource retention rate) (Ulanowicz 1980). For Building B, renewable energy collectors on the roof concentrate a large amount of energy into an element. Despite imbalance of energy flows through the formal elements, specialization of some system flow pathways is an efficient way to retain energy, because it can remove confusion in the networking of energy transmission. However, misleadingly increased efficiency causes the form to end up being brittle and, eventually, not sustainable. Other profiles show that the level of efficiency (AMI/H) is compromised, as the system moves from the brittle (Case 1 and 4) to the flexible (Case 2 and 3).

5.4.3.2 Envelope: Monthly (after 33 years)

Monthly investigation describes systemic performance of the building form according to the seasonal changes of building operation. It is useful to examine ecological impacts of air-conditioning methods and mechanical operational systems as well as the formal organization. This experiment samples data from the 33th year, because it is the time that difference in the information of Building A and B becomes the least and that they would not undergo abrupt alteration in the flow networking.

In Fig. 5.4.8, the information profiles of the test cases from Building A take on larger variability. Their information content tends to increase during winter and to

decline during summer with local ups and downs. Case 4's profile exhibits relatively stable fluctuation, carrying slightly greater average system power (3.44 bits).

Looking into the power profiles (Fig. 5.4.9 (a)), the baseline case maintains power very well during winter, but it drops most during the cooling load dominated periods (mid May to early October; sudden inclination occurs due to the occupant's vacancy for holidays). For the baseline, comparing it to its resilience and AMI (Fig. 5.4.9 (c) and (d)), we can identify that space heating mechanism and insulation is well-organized to increase complexity and robustness. However, its energy flow networking to resist outside heat and cooling demand is ill-suited to retain power, adaptability, and useful energy, and ends up losing information content of the form.

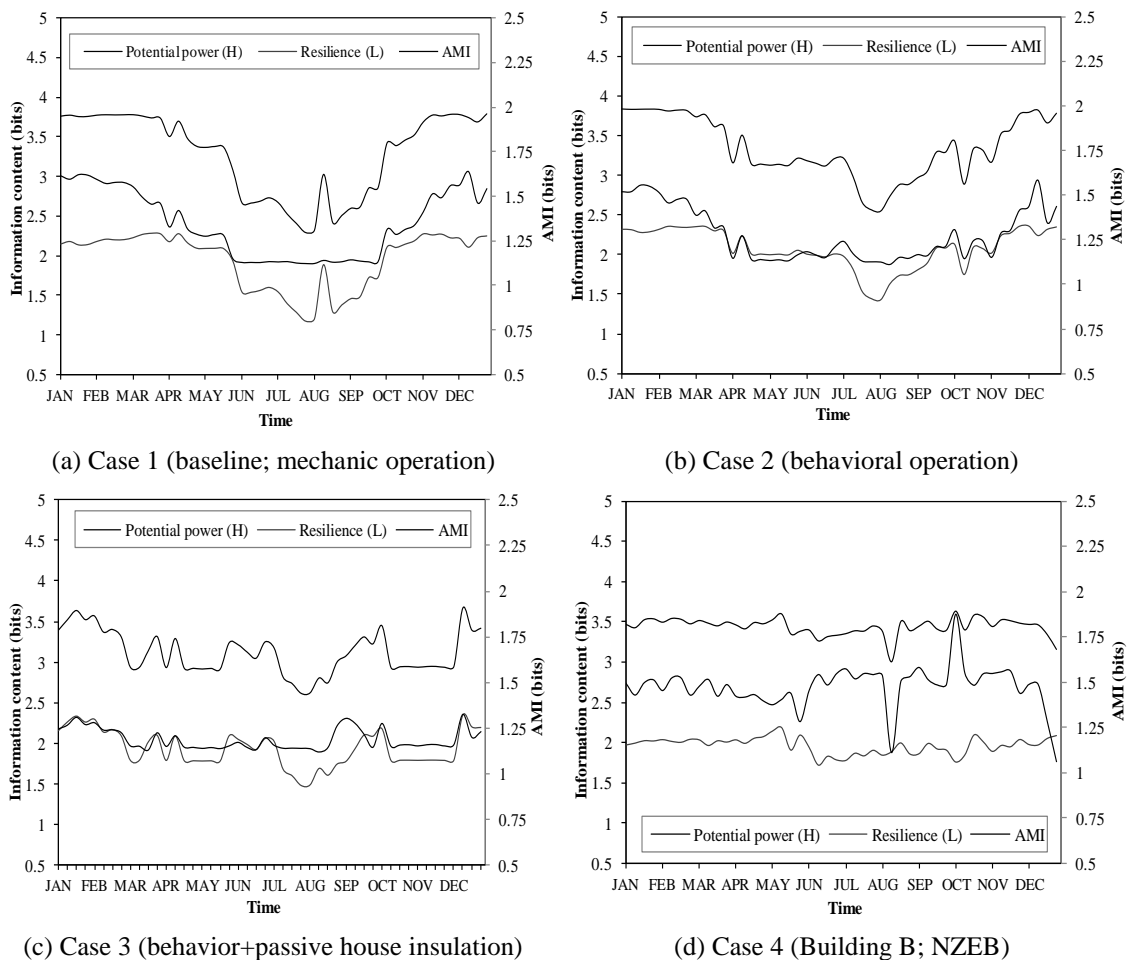
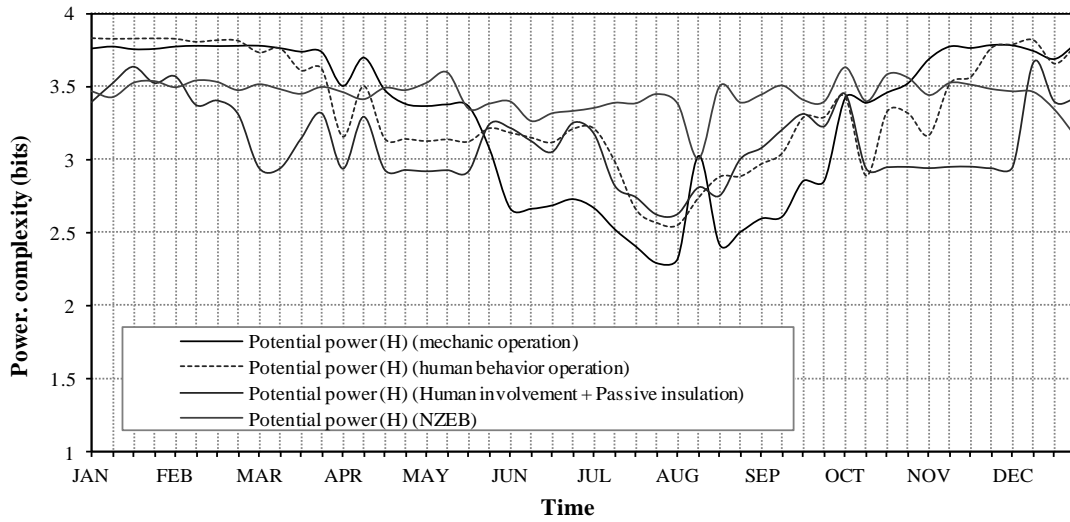

Fig. 5.4.8 Information content of the case study forms (monthly)

In Fig. 5.4.9 (a), applications of adaptive behaviors to the building form enhance performance in summer. However, both perform worse than the NZEB (Case 4), and Case 3 shows the worst performance in spring and winter. Even considering this

sampling test from the whole building life may be biased against the results of the life-cyclic information analysis (Section 5.4.3.1), this result follows that improve insulation and occupant behavior may be in conflict during a certain operational period, winter in this case.



(a) Potential power (monthly)

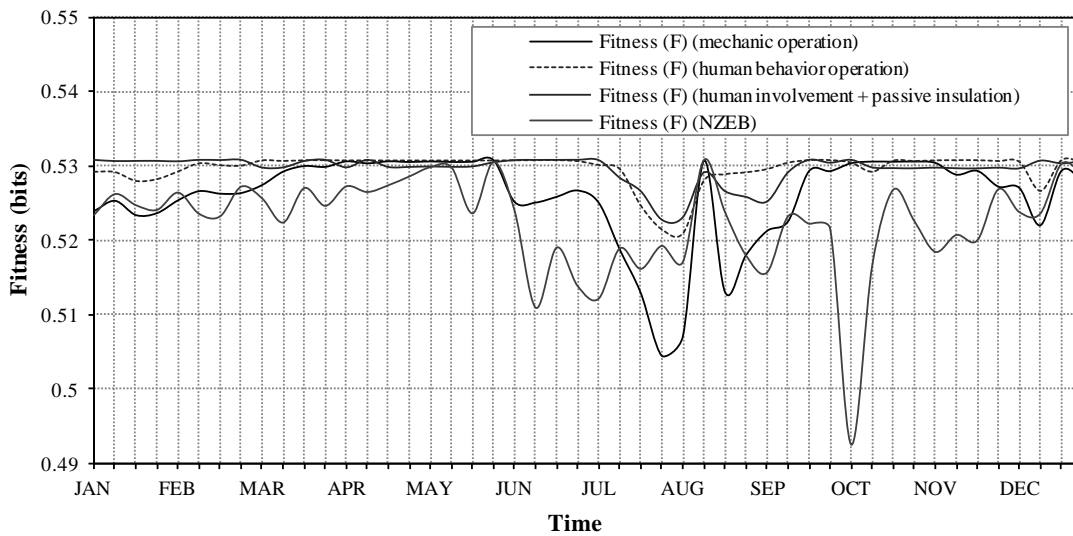

(b) Fitness profiles (monthly)

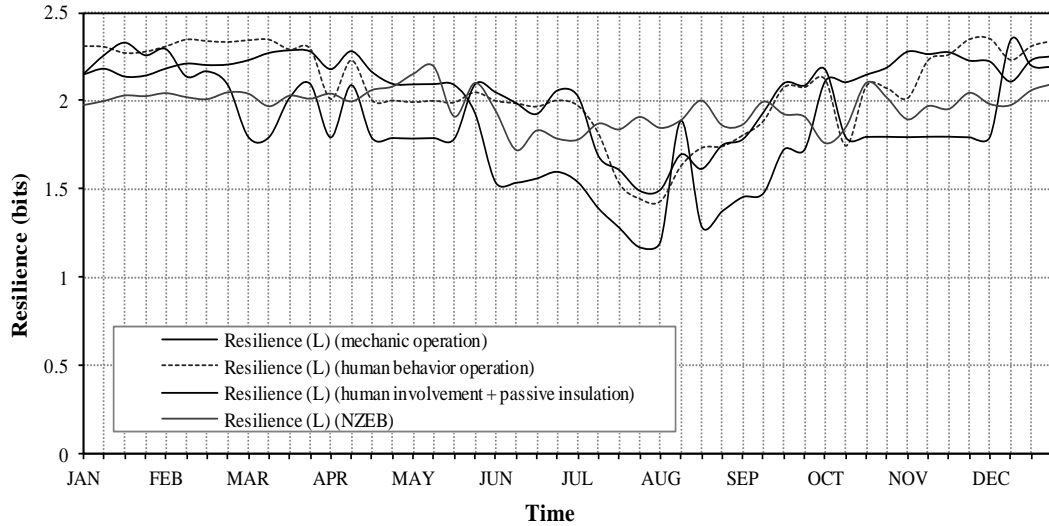

(c) Resilience profiles (monthly)

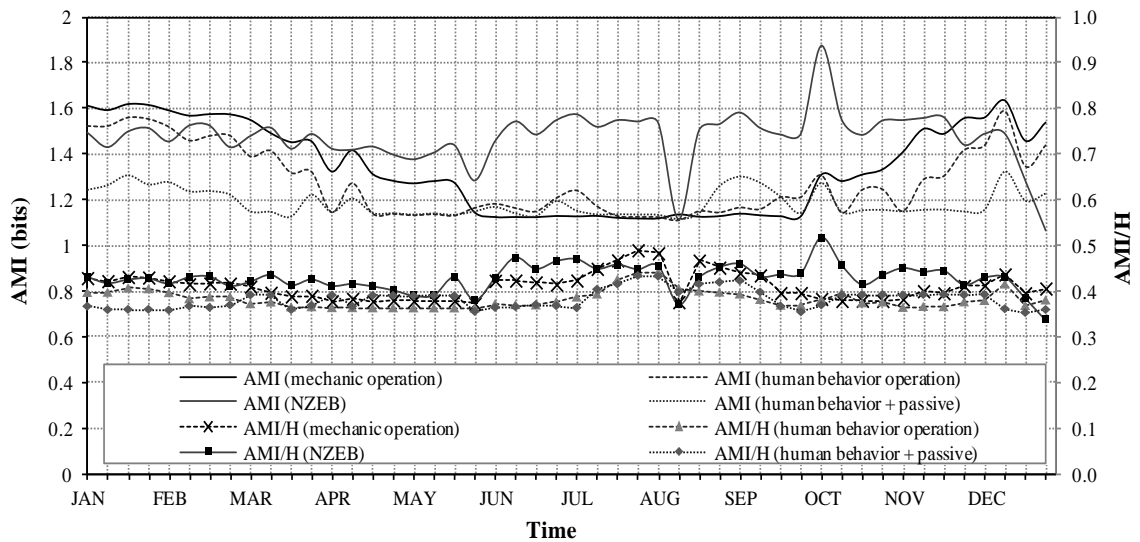

(d) AMI and network efficiency (AMI/H)

Fig. 5.4.9 Information profiles of the test cases (monthly)

Despite the fact that the difference in power, fitness values of all cases are similar during winter, it is noticeable that Case 4 lacks adaptability throughout the year. In particular, it shows the worst adaptability in early October. This means NZEB’s increased organization (primarily through the “specialization” of components and pathways; e.g., solar panels on the roof and complicated conditioning system that need greater nonrenewable inputs to manufacturing) outperforms the capacity of system network complexity and resilience (degree of freedom in resource choice and energy circulation). It is revealed by the highest efficiency (AMI/H) of the NZEB at

that time. Efficiencies of other human-involved cases (0.38 bits on average for Case 2 and 3) approximate the optimal value of 0.37 bits. This finding explains that the human-dominated control for the responsive building form activates feedback loops which eventually adjust system efficiency and increase the information content of form.

5.4.3.3 Envelope: Hourly (after 33 years)

The hourly variation of energy flow and information rests upon occupancy schedule, appliance use, and operational energy usage. Fig. 5.4.10 draws a comparison to observe the temporal change of networking pattern and its correlation to total flow quantity. For Case 1, the profile of system power (H) roughly parallels that of TST on June 21, but this does not seem to make sense on December 21. Despite reduced TST of Case 4 (Fig. 5.4.10 (a) and (b)), power is lower than Case 1. Especially during the daytime (12~17h), even if there seems no distinctive difference in TST between Case 2 and 4, information and system complexity of Case 2 are far greater than Case 4. It can be concluded that obscurity in the relationship between flow quantity and its networking quality reveals the lack of rigorous causality in the network configuration and performance measured with non-informational indicators like energy or emergy.

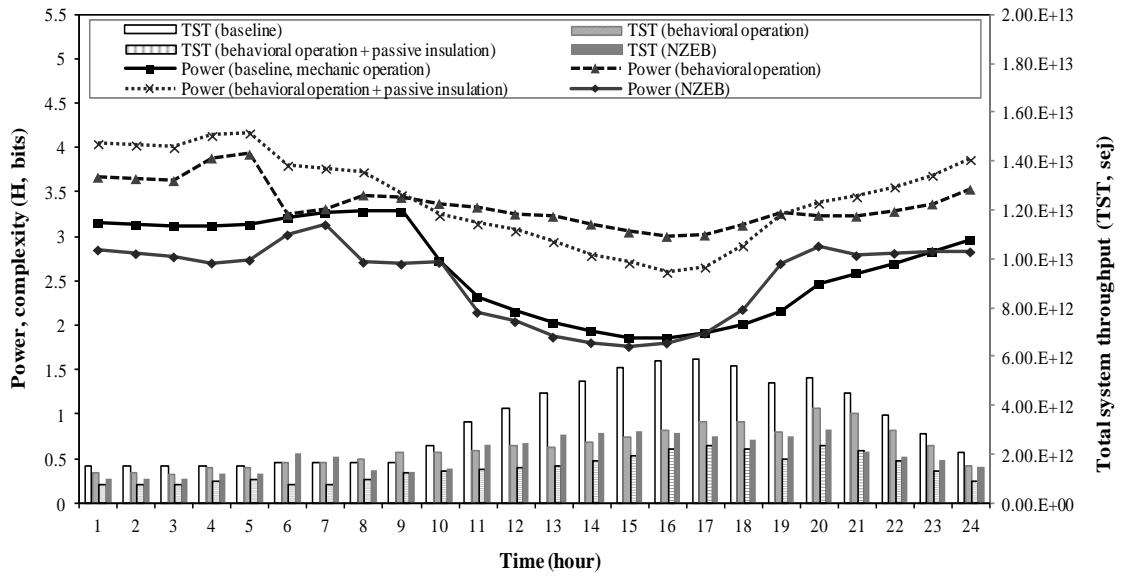

(a) June 21

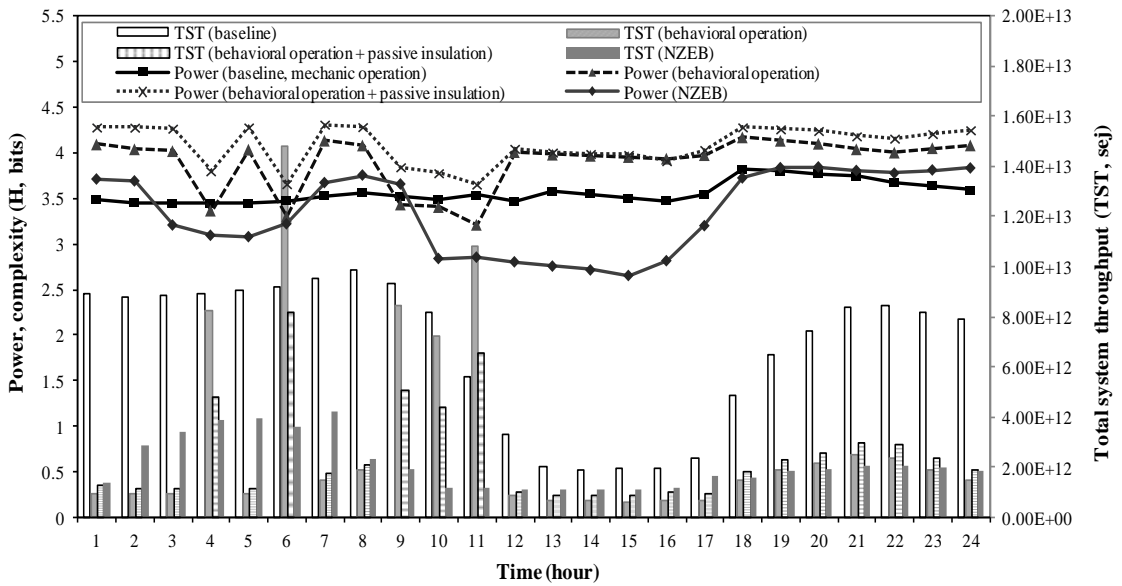

(b) December 21

Fig. 5.4.10 Variation of total system throughput (TST) and information content of system complexity (power)

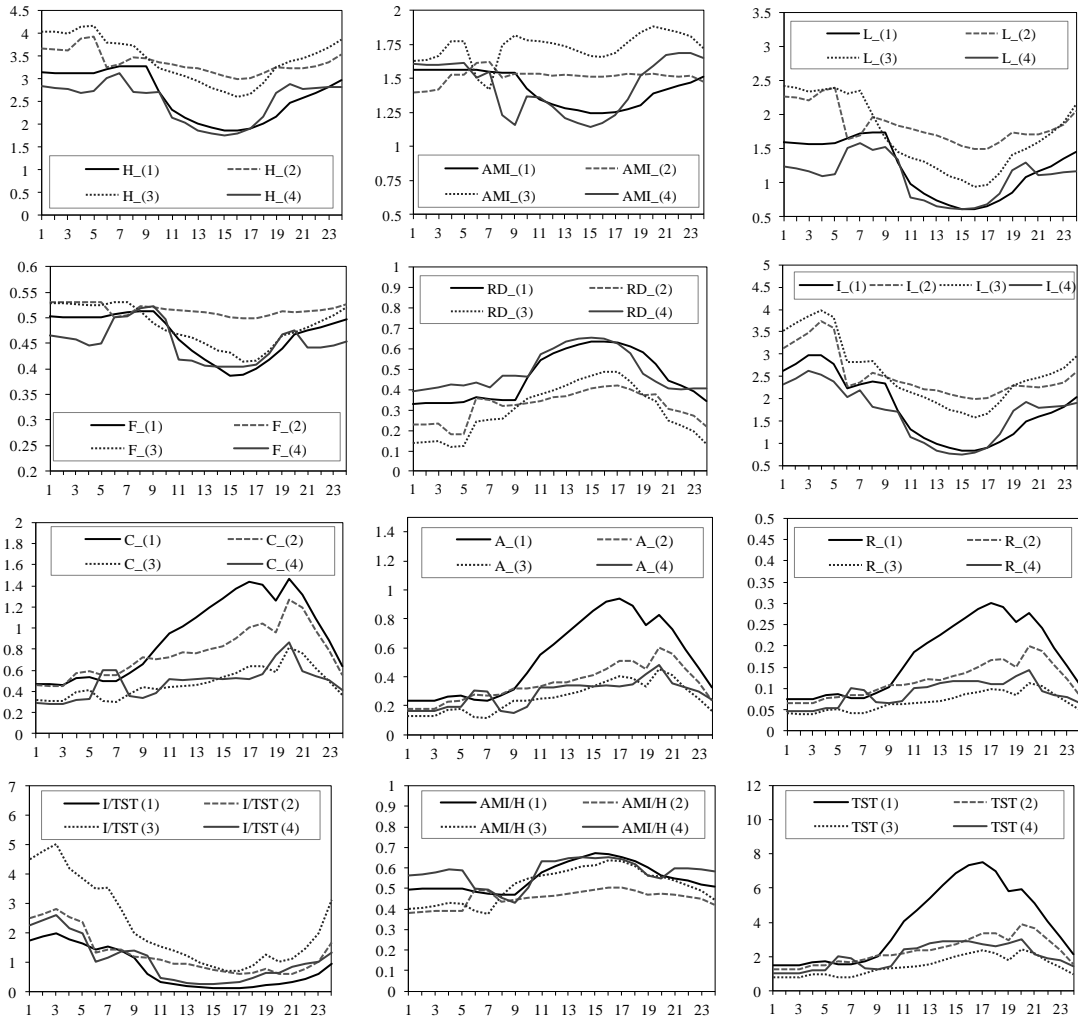

Fig. 5.4.11 Temporal variation of the system-based indices at June 21st:RD- redundancy, I- information (Units— C, A, and R: E+13 sej·bits; I/TST: E-12 bits/sej; TST: E+12 sej)

Graphs in Fig. 5.4.11 and Fig. 5.4.12 were drawn to characterize hourly variation of information content with ecosystem indicators. In Fig. 5.4.11, that power and AMI of Case 2 and 3 vary with correlation shows that the building form tends to follow the characteristics of ecosystem development as discussed in Section 5.4.3.1. Energy-conscious behaviors tend to increase resilience (L) and fitness (F), but it becomes reduced when insulation is added. Note that the building form of Case 3 loses adaptability significantly during the daytime. Redundancy (RD) refers to a degree of structuralization that limits flow choices. It is interesting to observe that RD values of Case 1 and 4 are similar, and that genetic information inputs lowered RD (Case 2 and 3). Higher RD gauges generally a level of ossification in potential reorganization of flows. So, it is identifiable that, for Case 1 and 4, energy organization through built

form is structuralized “too orderly” as if there is a lawful pattern to satisfy (which is regarded as mechanical; Ulanowicz, 2009), whereas there remains flexibility for lower RD cases. It tentatively follows that RD is useful to tell mechanical and adaptive (ecological) adaptation.

By definition, information content (I) can be estimated by subtracting system complexity (H) before getting built from that at a current state. Variation of information content, accordingly, tends to follow that of system power. Case 2 carries slightly greater information and power during the daytime and less than Case 3 during the time needed to keep internal heat (night time). However, improved insulation does not necessarily ensure information increase. Case 4 (NZEB) shows lessened power and information in spite of the same level of insulation as Case 3. This finding tells us again that formal organization matters, rather than quantity of energy or material use, in the evaluation of building performance. Meanwhile, the simple estimates from complexity may be biased, for it does not reflect the system scale. That said, the intensity of information per total energy fluxes (I/TST) demonstrates human intervention works well to accumulating building information.

Variation profiles of scale-sensitive indicators such as capacity (C), ascendancy (A), and robustness (R) demonstrate that differences of information per unit quantum can be offset by the system scale. Since TST is an indicator of system size growth, while information indicates internal development, we may say that Case 1 (baseline) is a growth-led developmental type relative to the others. Influences of growth level are identified in comparison with the network efficiency level. Looking at the AMI/H of each case, it is clear that increased efficiency of the baseline case is utilized to grow the system size and organization that fits a mechanical explanation. Thus, Case 1 and 4's increased flow scale endangers the forms when unforeseen perturbations occur from the environment. For the responsive building form (Case 2), it appears that various inefficiencies are engaged in transactions of material and energy. Nevertheless, it is also clear that the inefficiencies end up adjusting the external system size and facilitating internal development.

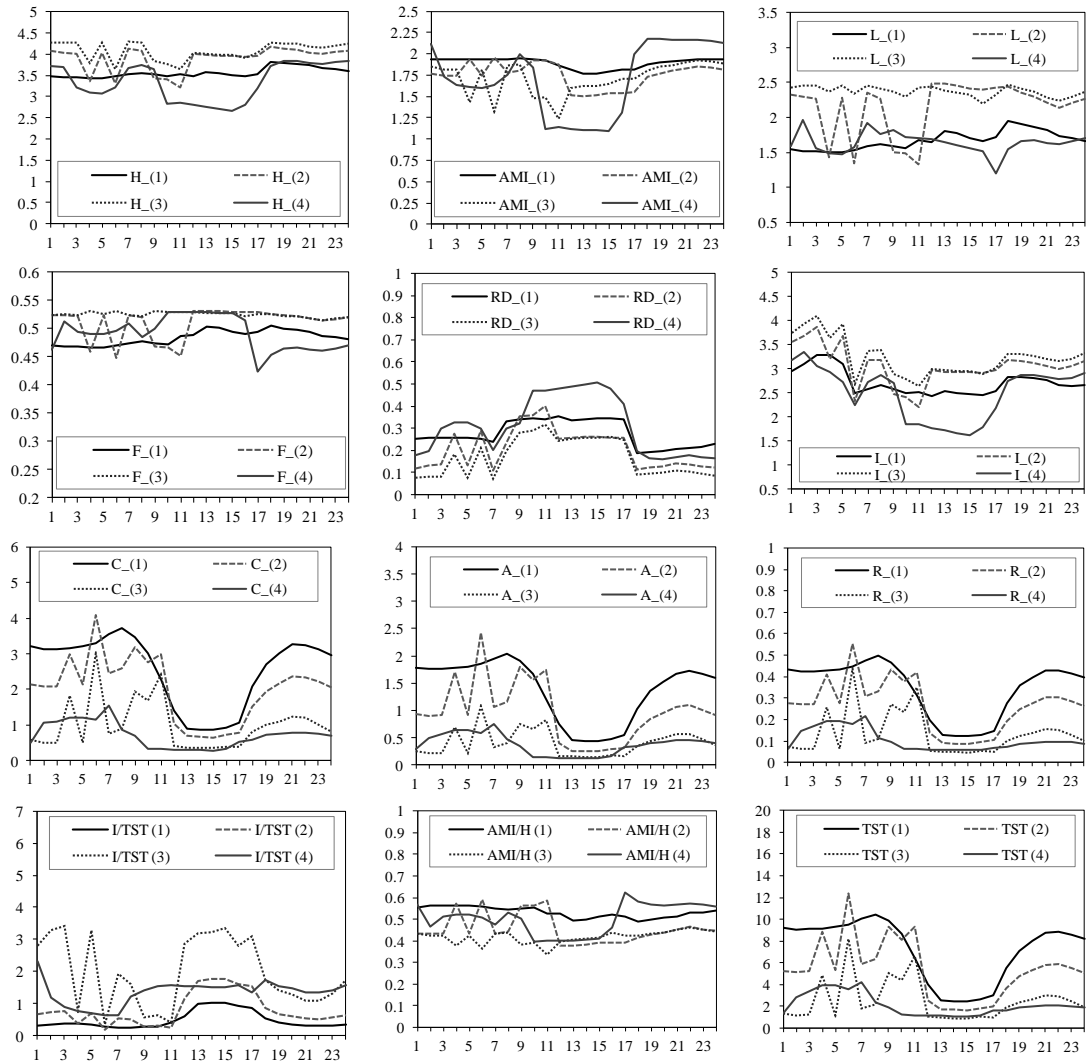

Fig. 5.4.12 Temporal variation of the system-based indices at December 21th: RD-redundancy, I- information (Units— C, A, and R: E+13 sej-bits; I/TST: E-12 bits/sej; TST: E+12 sej)

During winter, ecological characteristics of the temporal variation of information and associated indices (Fig. 5.4.12) can be explained in the same manner as summer. However, overall information content and power is the highest at Case 3, because additive insulation performs better in cold weather. A distinctive feature of the Case 2 and 3's variations is replication of sharp ups and downs in information content. This tendency explains that discrete occupant's decision-making in system control dominates the arrangement of energy flows through the building form. Comparison of H, AMI, and RD among the cases clarifies that NZEB tends to lose information when cooling demand becomes a key parameter of the system control. It is largely because (1) the increased insulation level is not effective to provide thermal comfort

during the daytime and (2) a great deal of nonrenewable inputs should be invested consistently, all the way through the daytime, to collect renewable sources from the environment. As a result, NZEB comes to have low information, resilience, and, even AMI during the day.

5.4.3.4 Significance of building form for the achievement of sustainability

In Chapter 1, it was hypothesized that information content accumulated from the building form plays a pivotal role in the the achievement of building sustainability as environmental buildings develop to reduce nonrenewable energy use. If we compare the information quantity of the whole system and the building envelope (Fig. 5.3.2, 5.3.4, 5.4.7, 5.4.9, and 5.4.10), it becomes clear that human-controlled responsiveness (information inputs) leads to a significant energy reduction (nearly zero energy use) and can make the building form sensitive to the variation of the configuration of flow network than that of energy quantity.

In effect, building form carries a greater amount of (useful) information than the whole building system, and, as the building adapts to its thermodynamic conditions (following the ecosystem principles; Odum, 1969) to the ambient environment, a relative amount of the building form's information increases. For instance, as for Building A, under the dominance of mechanical operation, annual average information contents are 3.51 bits for the whole system, 3.85 bits for the envelope Case 1, and 4.01 bits for the energy-reduced responsive form (Case 3). For Building B, it shows 2.98 bits for the whole and 3.57 bits for the envelope. Greater information of the building form and further increase due to energy reduction through human behaviors substantiate the initial hypothesis made on the coherence of energy reduction, greater information, system power, and building sustainability.

5.5 System phase analysis

Time-based analyses demonstrated that the import of lesser non-renewable energy to buildings generally results in an increase of the emergy-flow-network complexity (H; potential power), fitness, and resilience and the adjustment of efficiency (AMI/H) and AMI. However, it is still unclear to understand (i) the causality between information indices in the adjustment of material and energy flowing pattern and (ii)

its relationship with empower (sej/time). As demonstrated in Chapter 3 and Section 5.3 and 5.4, if the number of system component increases, the three increasing indices (H, F, and L) tend to maximize at different efficiency levels. For this reason, it is necessary to explore the phase change of system status to identify (i) the final goal of system's environmental behavior and (ii) the quality of consistency of building system behaviors with the ecosystem development.

5.5.1 Diversity of inputs and outputs and the proxy of empower

Buildings can generate useful environmental resources (e.g. information) with an involvement of human dwelling. However, unlike natural systems or living organisms, a building-as-a-shelter (physical structure and space) is not productive, as it demands a large amount of energy and materials for construction, maintenance, and operation. Due to the uncertainty and lack of reliable data about occupants' production to larger systems (e.g. human economy), this experiment concerns only physical building structure and enclosure associated with space conditioning during a normal life cycle. For this reason, the system status of test buildings end up degenerative; they consume input energies and materials, while the output of the buildings is nearly zero. This can be led to biased results inconsistent with maximum empower principle and the definition of empower—a generative system property gained from productive self-organization of inputs and outputs. Therefore, in order to evaluate the positive aspect of building's empower properly, total system information (TI_s; Tilley and Thompson, 2015) is introduced here as a proxy of empower based on the inputs and outputs of building energy and materials. By definition, TI_s is the difference of total information between inputs (TI_i) and outputs (TI_j) such that TI_s is TI_j – TI_i. If a building has no output, TI_j becomes zero and TI_s is – TI_i. TI_i is calculated by,

$$TI_i = H_i \times Em_i$$

where H_i is Shannon index (diversity) of input sources and Em_i is the total emergy of inputs. By measuring Em_i of a building on a specific time basis, TI_i and TI_s can eventually represent the total carrying capacity of emergy inputs and outputs.

Accordingly, TI_s is used to approximate building's empower with the presumption that the less degenerative corresponds to more power.

5.5.2 Whole system (life-cycle and monthly observation)

Fig. 5.5.1 (a) presents the empower change of test buildings. Energy gained from renewed inputs (e.g., operative energies, materials for maintenance) generates local peaks (at the 16th, 21st, 30th, and 42nd year). Building A (non-NZEB)'s empower profile shows relatively low and stable variations, and Building B (NZEB) shows more frequent, large fluctuation, due to its more complicated building material use and replacement schedules. Monthly observation indicates different results. While Building A's empower varies from $6.13\text{E}+14$ to $9.05\text{E}+14$ sej/quarter month, Building B's empower remain constant at around $4.50\text{E}+14$ sej/quarter month.

For both cases, the degradation of building materials and service inputs decreases empower in the early years. However, this negative effect can be understood “positively”, as the degradation is due to the reduction of nonrenewable inputs. Thus, by introducing total system information ($\underline{\text{TI}}_s$), empower can be assessed as a positive system property associated with a potential energy output to increase $\underline{\text{TI}}_s$ (Fig. 5.5.1 (b)). The assessment of empower of test buildings based on $\underline{\text{TI}}_s$ parallels the hypothesis of this study that human involvement and design to decrease environmental impact help buildings carry more information content.

In the empower profiles (Fig. 5.5.1 (a)), Building B has lesser energy inputs (empower) with amplified variations. However, whole system empower measured with $\underline{\text{TI}}_s$ reverses this relationship. $\underline{\text{TI}}_s$ indicates that Building B is likely to have more empower due to more useful information inputs to decrease nonrenewable resources and environmental impact (Fig. 5.5.1 (b)).

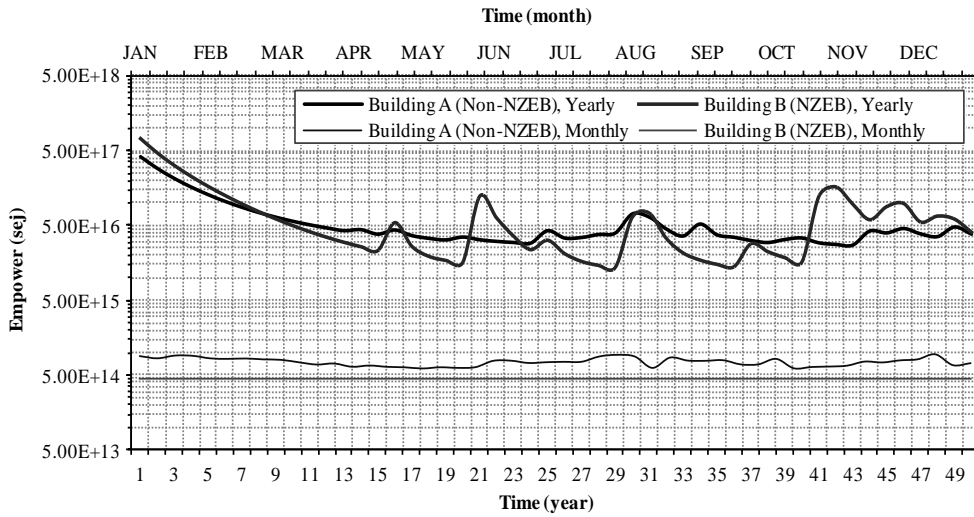

(a) Temporal variation of degenerative empower

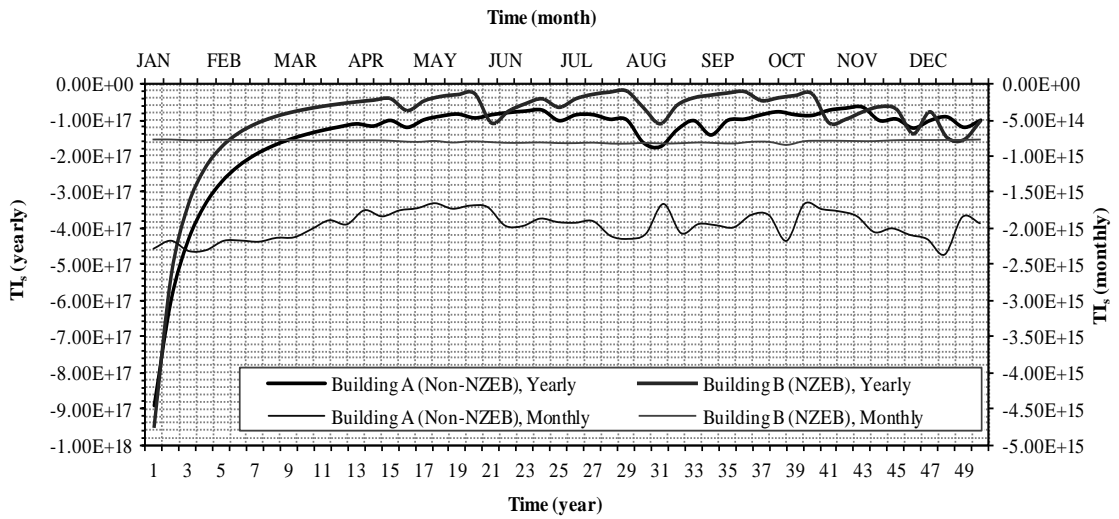

(b) Temporal variation of total system information (TI_s)

Fig. 5.5.1 Empower profiles of test buildings (whole system)

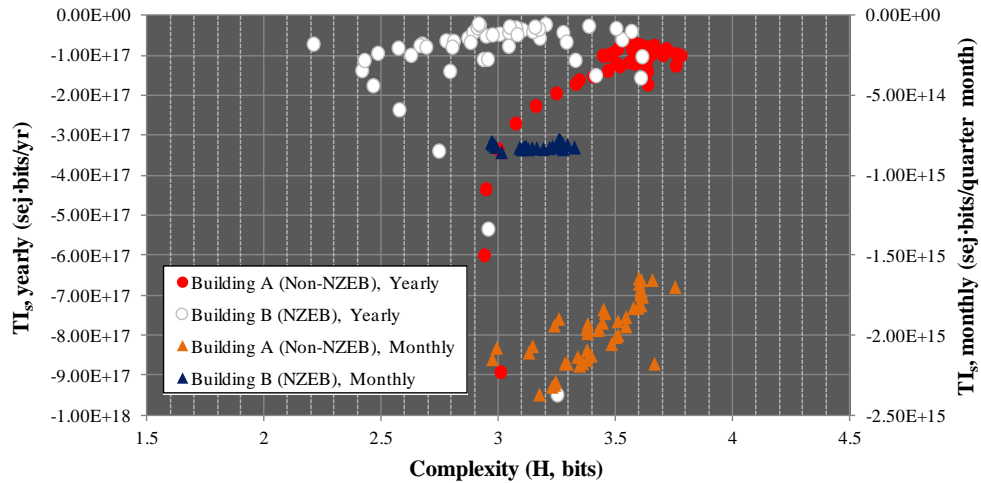
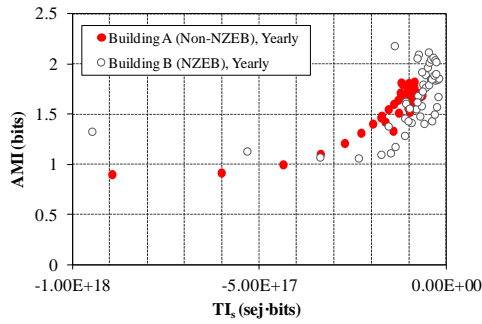

Fig. 5.5.2 Total system information (TI_s) and complexity (H)

Even though TI_s can be a proxy of empower, it should be distinguished from H, which is defined in this study as a proxy of system power or potential system power. H considers system power gained from internal and external system organization, whereas TI_s concerns only external inputs and outputs. For the application of maximum empower principle to this study, the use of TI_s is more desirable, because it is technically closer than H to the definition of empower in emergy theory. Fig. 5.5.2 reveals this inconsistency of TI_s and H, but the results indicate that an increase of empower of building systems is closely related with incremental complexity. This demonstrates that building's systemic behavior follows Eugene Odum's principle of ecosystem development, and it is also consistent with the results of theoretical tests (Chapter 3) that lesser nonrenewable emergy inputs result in an increase of H. A linearity between empower (TI_s) and complexity (H) is more distinctive in the monthly analysis (that shows periodic ups and downs of operative inputs), while the life-cycle observation seems to include irregularity due to the complicated combination of operational and maintenance phases. It is important to note that maximum empower may not rigorously guarantee maximal complexity (H), due to the internal system organization. Constant inputs per month of Building B during a year resulted in constant empower, TI_s , but H was changed. It confirms that the building system can self-organize internally to increase complexity regardless of external imports or exports. For example, the use of renewable inputs and the internalized circulation of nonrenewable inputs can make a contribution to increase system complexity.

Phase plots in Fig. 5.5.3 present relationships between empower and informational building performance. In the life-cycle analyses (Fig. 5.5.3 (a), (c), and (e)), Building A and B show similar patterns, even though system behaviors appear complex; the system efficiency-related indices (AMI and AMI/H) tend to increase according to the initial increase of empower (TI_s ; the reduction of non-renewable energy inputs and the decreased uncertainty of resource distribution). These phenomena seem to run counter to the ecosystem hypothesis that the development of an ecosystem adjusts efficiency. However, the annual increases of AMI and AMI/H and the decline of the resilience of test buildings mean that the reduction of non-renewable power can work to organize an energy-networking structure until the building systems become stabilized (compare with Fig. 3.4). It demonstrates that buildings during the early developmental stages are under a growth-driven status in which sacrifices system stability and robustness for growth. In the later stages, we can identify that test buildings tend to adjust AMI, AMI/H, and resilience, like developmental ecosystems, when empower increases.

In the results of monthly analysis (Fig. 5.3.3 (b), (d), and (e)), it is clearer to identify the ecological behavior of test buildings. For the Building A's phase-changing patterns, network efficiency and organization level (AMI/H and AMI) is reduced with empower (TI_s) increased. AMI/H, in particular, tends to approach the maximum value of 0.37 (Fig. 3.11). The proportional relationship between TI_s and resilience (L) demonstrates the general consistency between empower and resilience in the hypothetical tests (Chapter 3). Nevertheless, Building B's behavior does not parallel this expectation. Its systematic (informational) indices do not appear to correspond to the empower change. This result suggests that high-performance buildings with increased mechanical efficiency do not follow the principles of ecosystem development and may end up unsustainable. On the other hand, differences between the profiles of monthly and annual phase changes indicate that building performance during a stable stage (33years later in this experiment) fits better into the general ecosystem phenomena of development to increase the system adaptability and robustness.



(a) AMI and TI_s (life cycle)

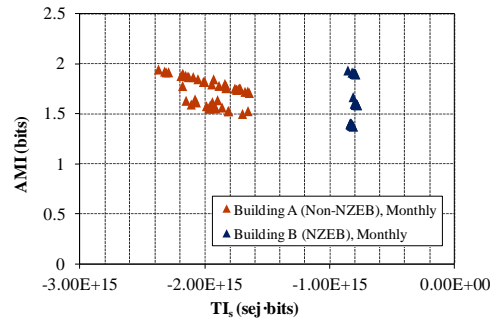

(b) AMI and TI_s (monthly)

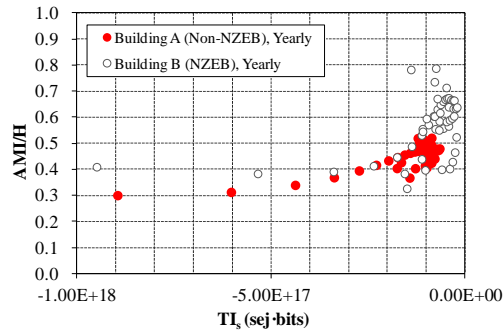

(c) Efficiency (AMI/H) and TI_s (life cycle)

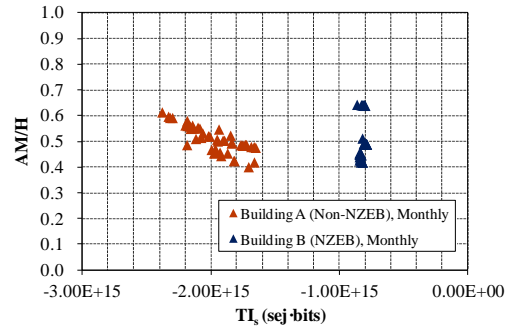

(d) Efficiency (AMI/H) and TI_s (monthly)

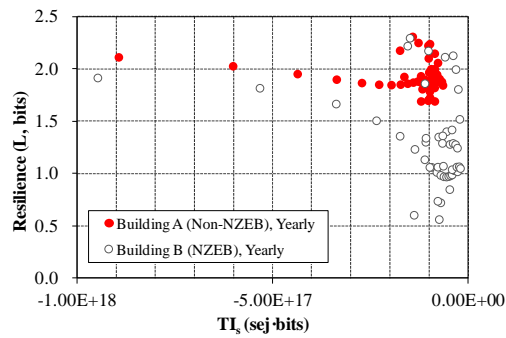

(e) Resilience and TI_s (life cycle)

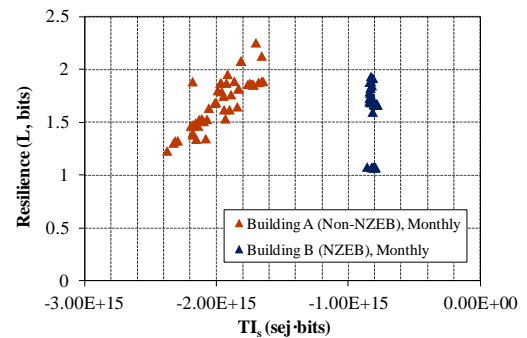

(f) Resilience and TI_s (monthly)

Fig. 5.5.3 Phase plots: Total system information (TI_s) and building performance

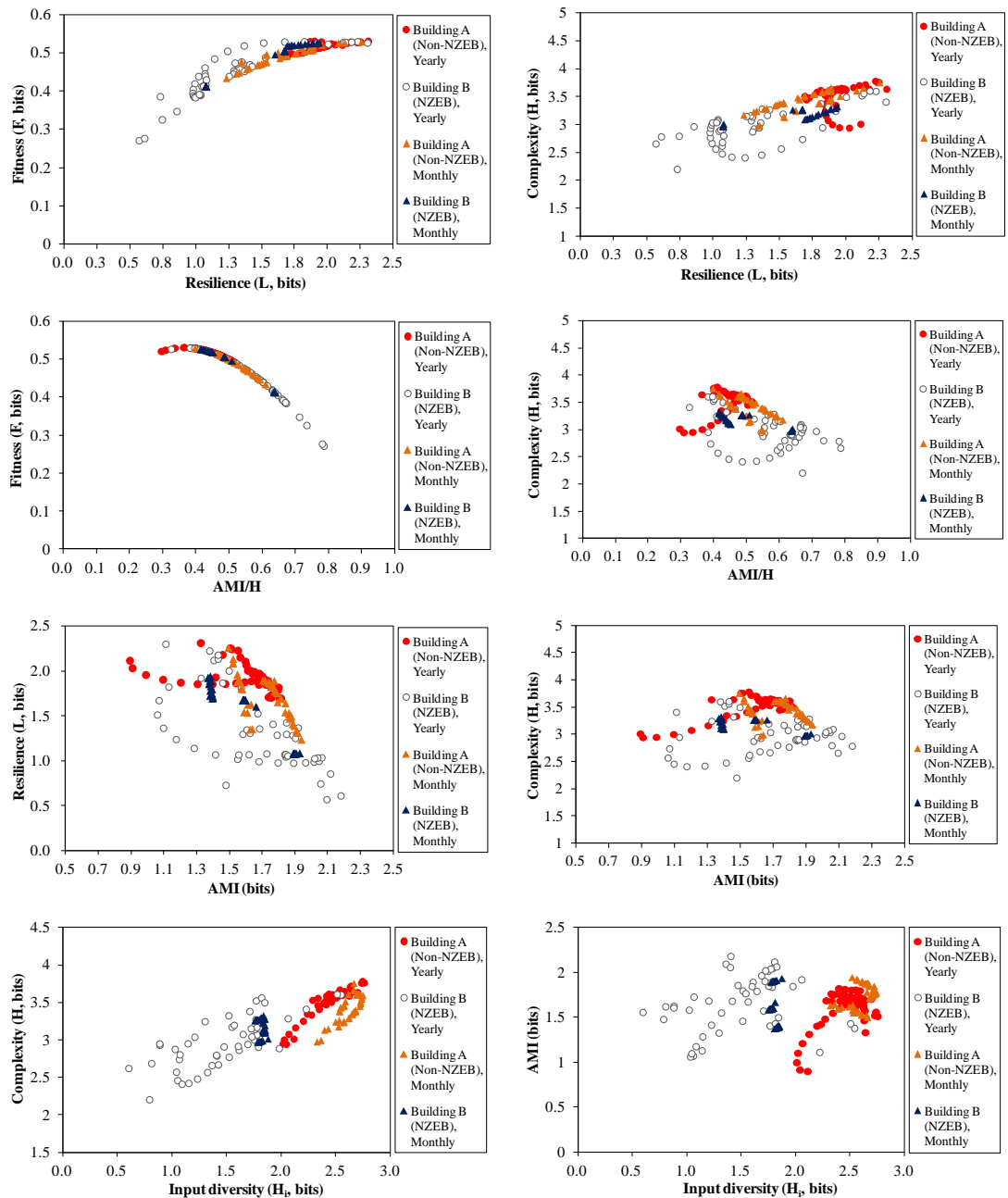

Fig. 5.5.4 Phase plots of information indices (whole building system)

In Fig. 5.5.4, a mutual increase of H, F, and L demonstrates that greater diversity of resource flows ensures system's enhanced robustness, adaptability, and sustainability. Building A's H and L concentrated relatively more with larger values indicate that Building A's system status is more favorable to stable development (sustainability). This interpretation is also proved in the profiles of F and AMI/H. Building A is closer to the point that F is maximized (0.37, 0.53), while Building B's profiles are scattered with greater efficiency. Most AMI/H values of both buildings are

greater than 0.37. This result confirms that buildings are ecologically well-developed system, as the built environment is. On the other hand, reduced AMI and AMI/H corresponds to greater H and L. If we consider external information inputs (that could not be measured in this experiment) for building design and management, H refers to potential power (power for all inputs including information). In this sense, the results show an intermediate level of efficiency at the maximal level of potential power.

5.5.3 Building envelope

Phase plots of the information indices about the building envelope were drawn by sequential time frames of observations such as from hourly to life-cycle. Each observation showed distinctive patterns and periodic behaviors. The interpretation, thus, begins with the hourly basis, and time windows are gradually extended to characterize a general systemic tendency, since a short time frame can make the observation of complex phenomena clearer.

5.5.3.1 Envelope: Hourly (After 33years)

(1) June 21th

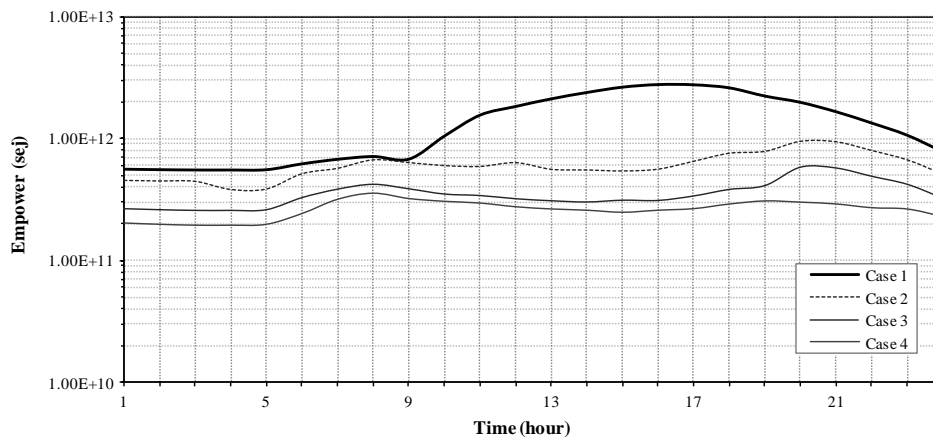

(a) Hourly variation of degenerative empower

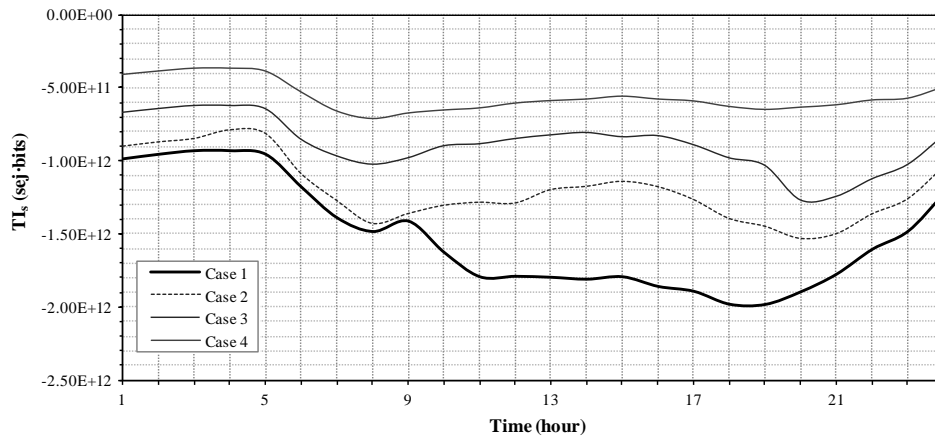

(b) Hourly variation of total system information (TI_s)

Fig. 5.5.5 Empower profiles of test buildings (envelope) at June 21th

Fig. 5.5.5 (a) shows that Case 1 (Building A, non-NZEB, and mechanical operation) is operated with the greatest energy inputs. The demand of space conditioning (cooling) during the summer daytime (09~17h) increases empower of nonrenewable inputs (electricity). Behavior-based control (Case 2) reduces the use of electricity, and the well-insulated enclosure decreases it more, nearly close to the NZEB (Case 4). Accordingly, the measurement of TI_s indicates that Case 4 has the greatest empower of generative potential and Case 1 has the lowest empower (Fig. 5.5.5 (b)).

Fig. 5.5.6 (a) demonstrates that building's increased mechanical efficiency (high-performance) can disturb its ecological development. As the form of Building A increases power (from Case 1 to 3), system complexity (H) also tend to increase. Fig. 5.5.6 (b) and (c) also confirm that system efficiency is adjusted if empower increases, and Fig. 5.5.6 (d) suggests that high-powered buildings can be more resilient. However, even though Building B's envelope (Case 4) carries the greatest power, the scattered distribution prevents to find a clear linearity between empower and complexity, AMI, and resilience.

In Section 5.4, it was confirmed that human engagement enhanced ecological building performance and Case 2 was the most robust and highly adaptable than other cases. Fig. 5.5.7 supports these arguments. Complexity (H ; potential power), fitness (F) and resilience (L) of Case 2 are concentrated with greater values. The efficiency (AMI/H) of Case 2 is also more optimized (closer to 0.37). In the plot of AMI/H and F , AMI/H values greater than 0.37 demonstrate that all cases are well-developed and

energy networking of Case 1 and 4 can be brittle, because of high efficiency. The relationships of H , L , and AMI demonstrate that Case 2 and 3 (human behavior-based building operation) are more likely to follow ecosystems behavior than a mechanically operated building or high-performance building (NZEB).

The diversity of energy inputs (H_i) and the whole system diversity (H , complexity) have a closer relationship than the whole building system. The clear linearity of Case 1 means that mechanically conditioned buildings are vulnerable to an external perturbation in resource acquisition. Increased insulation and building operation with less energy use cause buildings to self-organize. Nevertheless, the fact that excessively efficient organization (a large amount of environmental inputs through a certain pathways) disturbs robustness is demonstrated through Case 3 and 4.

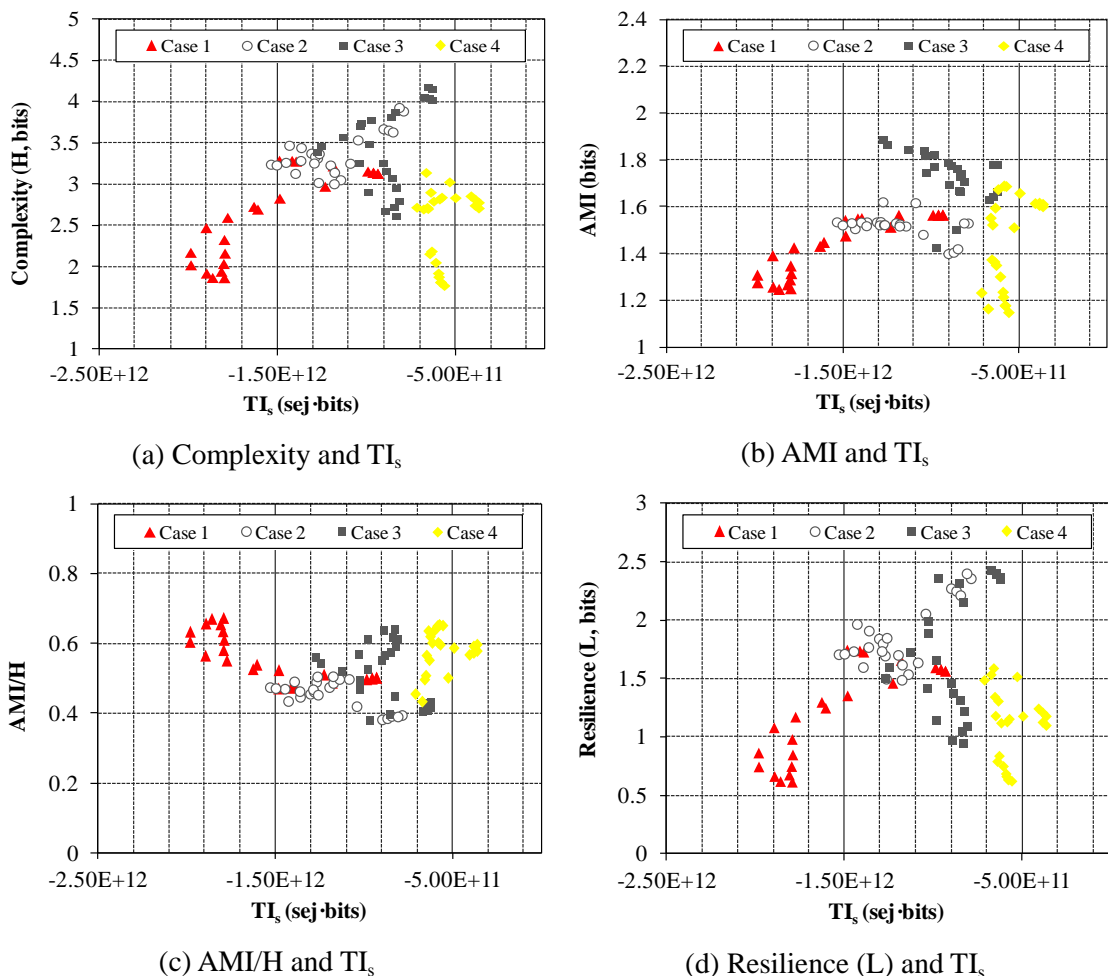

Fig. 5.5.6 Phase plots: Total system information (TI_s) and building performance (June 21th)

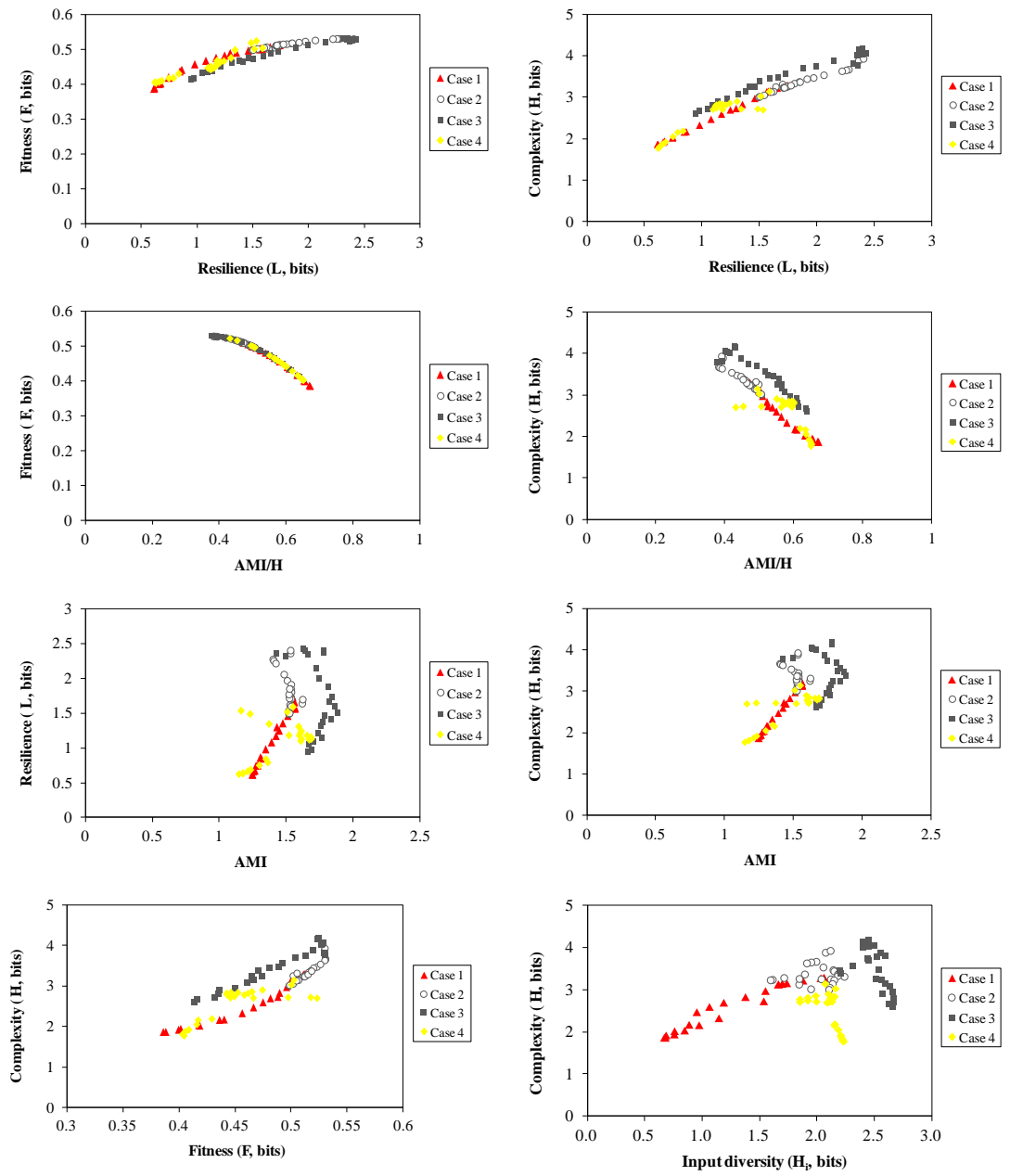
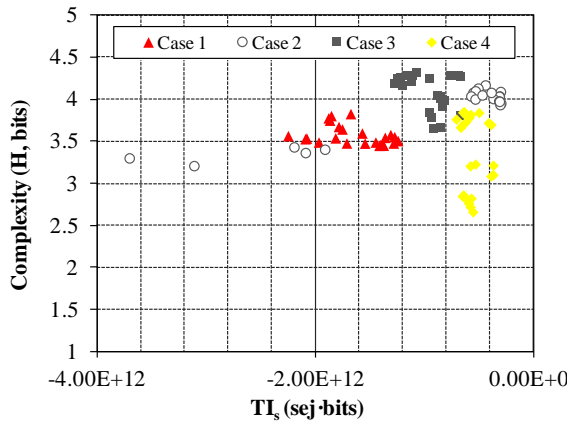
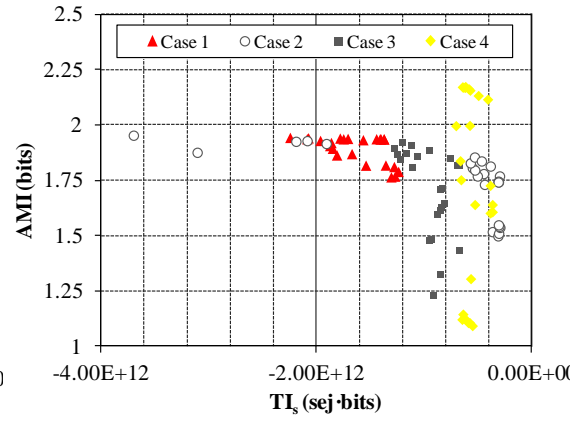

Fig. 5.5.7 Phase plots of information indices (June 21th, building envelope)

(2) Hourly: December 21th



(a) Complexity and TI_s



(b) AMI and TI_s

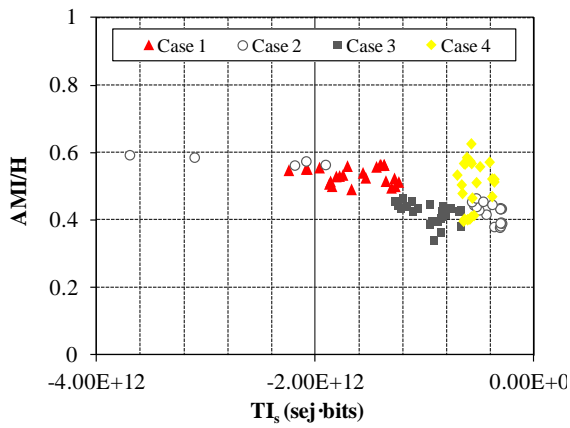

(c) AMI/H and TI_s

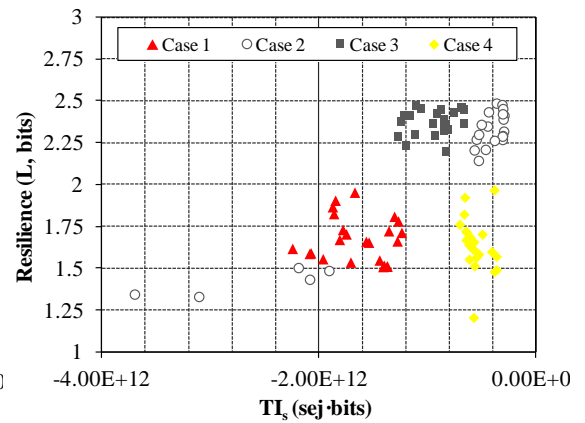

(d) Resilience (L) and TI_s

Fig. 5.5.8 Phase plots: Total system information (TI_s) and building performance (December 21th)

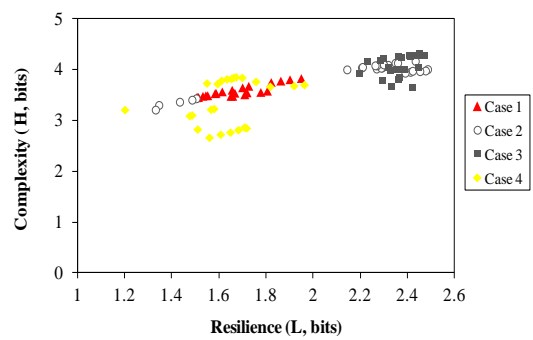
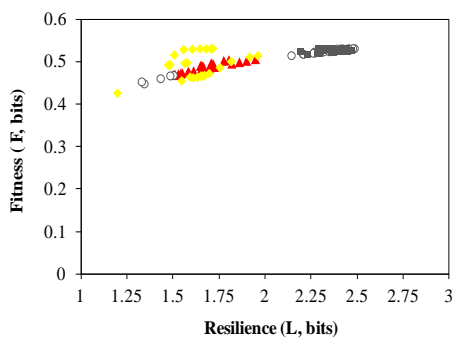

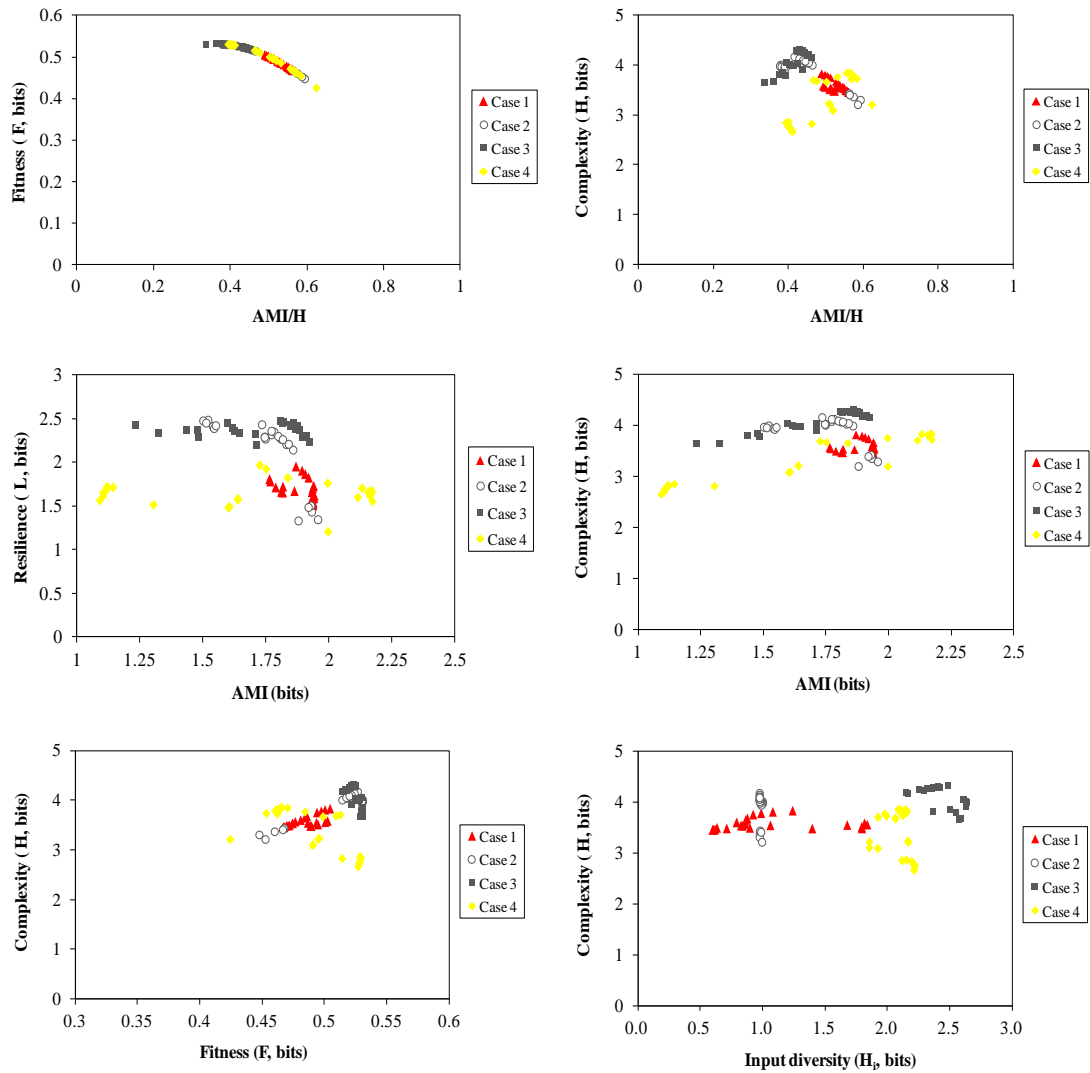
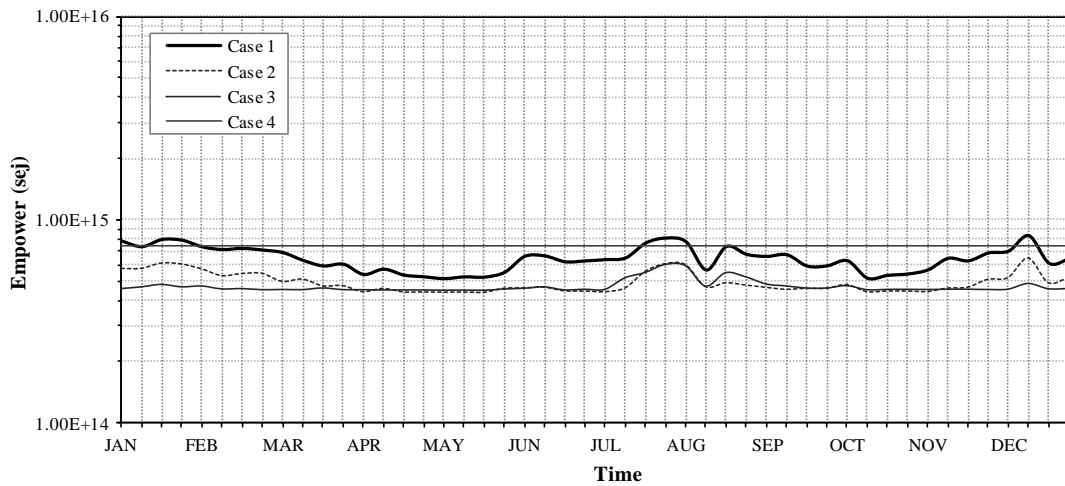

Fig. 5.5.9 Phase plots of information indices (December 21th, building envelope)

During heating-dominated hours, relations between empower and information indices are not clear compared to summer. Each plot shows coarse parallelism between building and ecological behavior (increasing complexity and adjusted efficiency). The scattered distributions indicate that each case goes through complicated phase changes (Fig. 5.5.8). Plots in Fig. 5.5.9 show that Case 3 (human control+ passive-house-level insulation) is most adaptive to the climate condition; it maintains a higher level of complexity, fitness, and resilience in spite of the variation of system organization (AMI and AMI/H). It also shows the greatest H_i and H while Case 2 stays at the low H_i level.

5.5.3.2 Envelope: Monthly (after 33 years)



(a) Monthly variation of degenerative empower

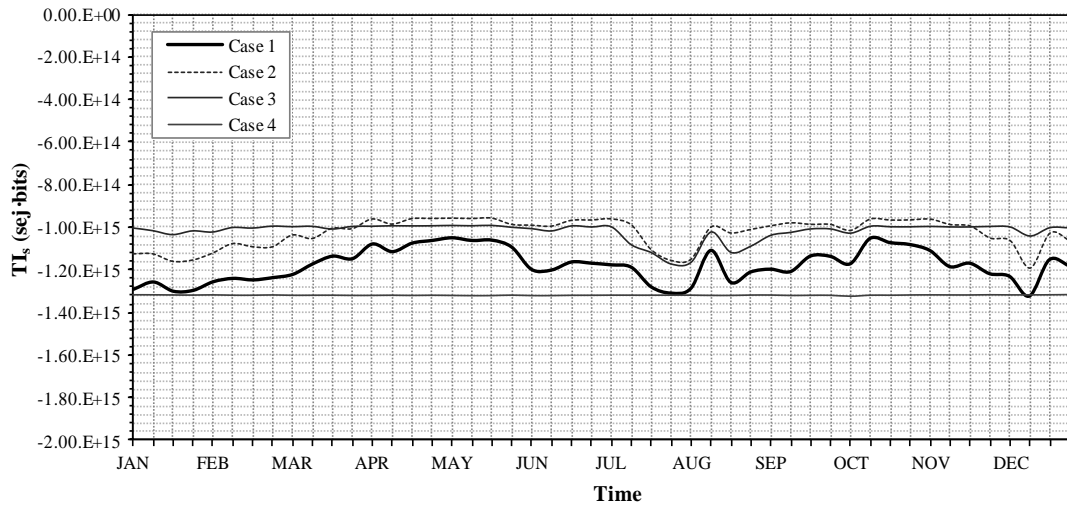

(b) Monthly variation of total system information (TI_s)

Fig. 5.5.10 Empower profiles of test buildings (envelope), monthly analysis

Due to constant material inputs to generate renewable energy, Case 4 (NZEB envelope) becomes the most degenerative (Fig. 5.5.10 (a)) and ends up the lowest empower (TI_s). Case 2 is generally more generative than Case 3, but the greater TI_s of Case 3 during winter indicates that it performs better during heating seasons (Fig. 5.5.10 (b)).

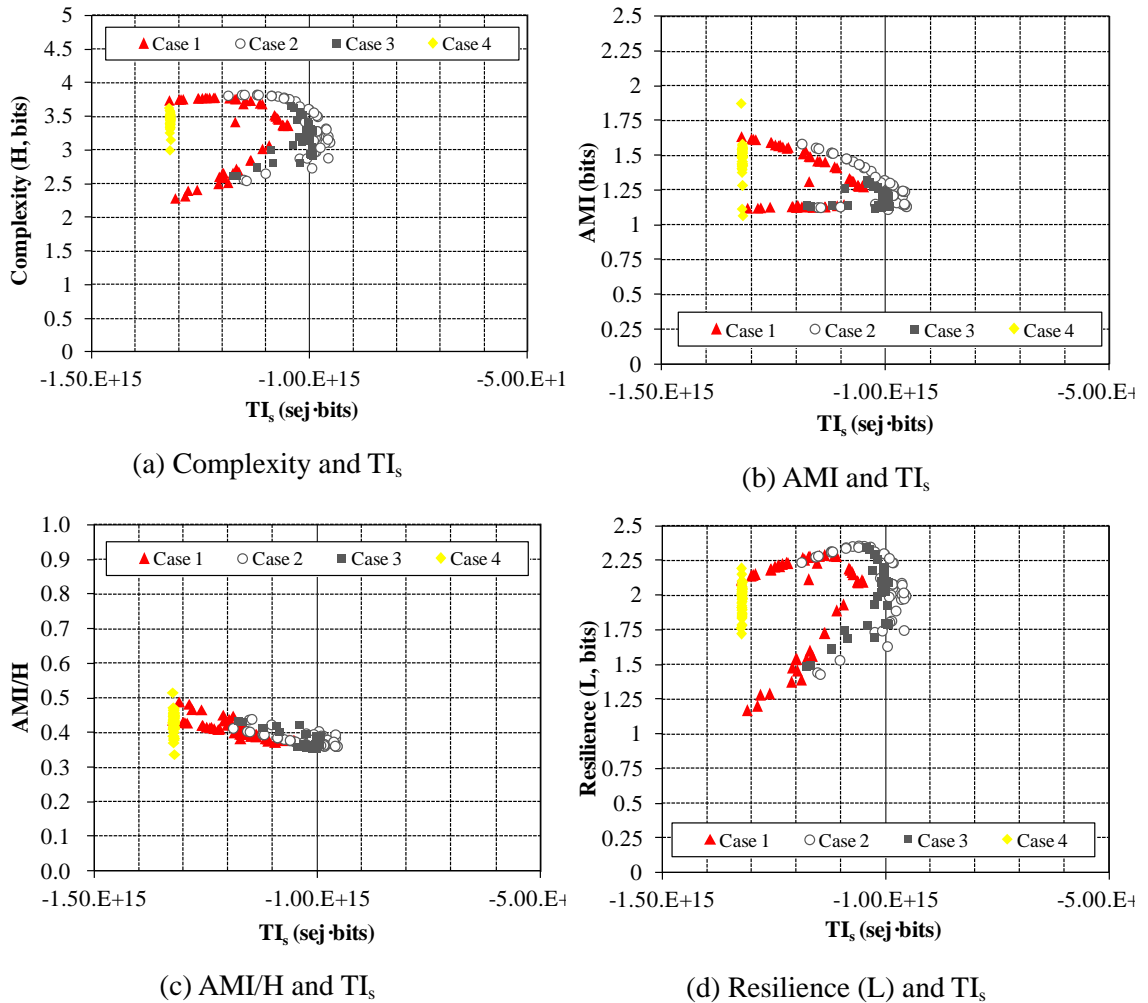

Fig. 5.5.11 Empower profiles of test buildings (envelope), monthly

In Fig. 5.5.11, the cyclic (seasonal) supply and depreciation of operative energy and material result in parabolic curves in the empower-complexity relationship of Building A (Case 1, 2, and 3). During summer, Building A's systemic behavior marks a clearer proportional linearity between empower, H, and L. In winter, H and L are relatively insensitive to the change of empower, which means Building A is more efficient to space heating. It is interesting to find that H is compromised when the building is the most generative, while resilience tend to be maximized (Fig. 5.5.11 (a) and (d)). This result reveals that buildings can be sustainable in such a way that empower increases resilience more immediately than complexity. Fig. 5.5.11 (b) and (c) show that efficiency is at a reduced level when empower is maximized. On the other hand, results also demonstrate that Case 4 (NZEB) has little to do with the generative properties of ecosystem development and, nevertheless, it self-organizes regardless of empower change.

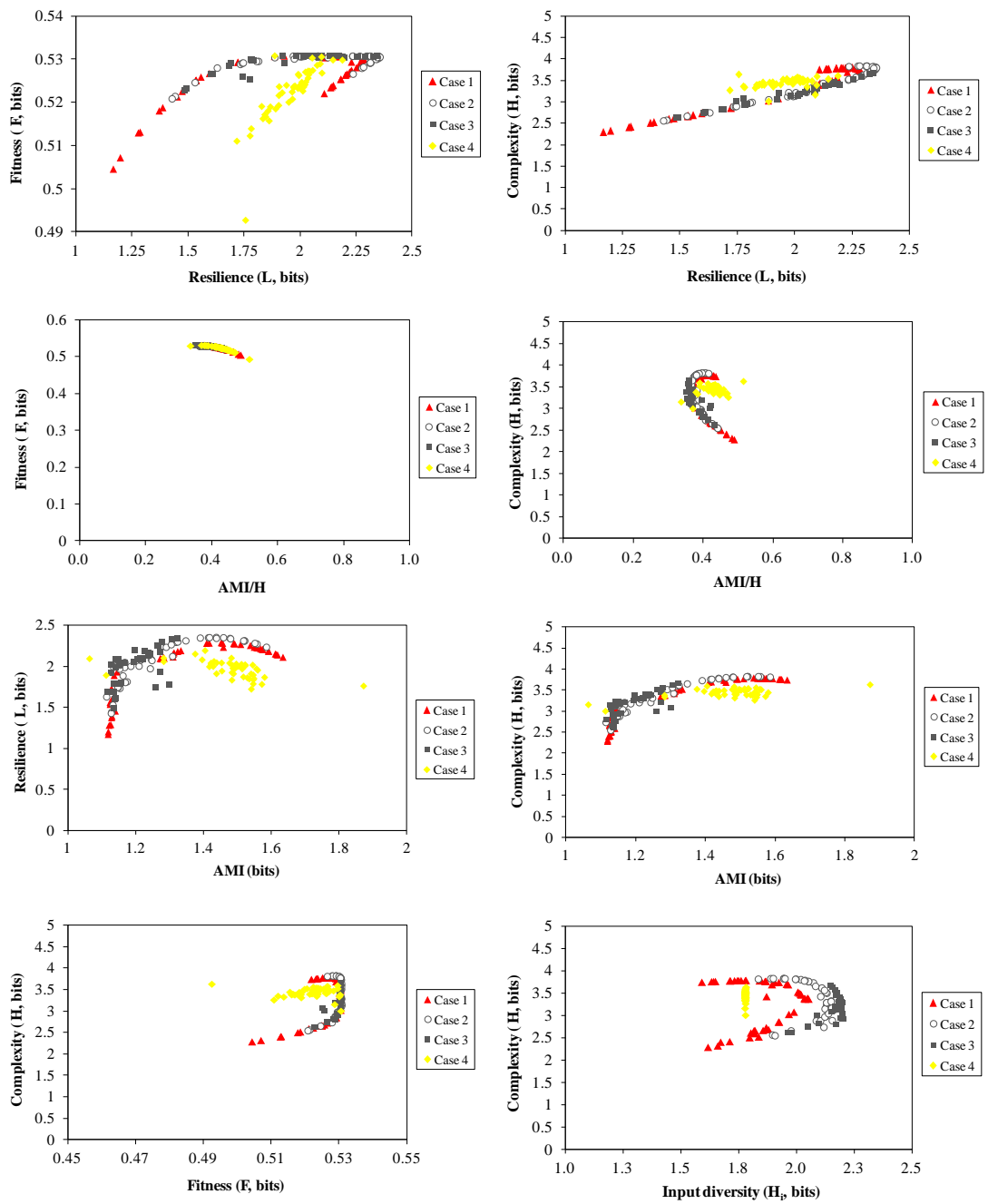

Fig. 5.5.12 Phase plots of information indices (envelope), monthly

In Fig. 5.5.12, plots about H, L, and F indicate that Case 3 is more robust, adaptable, and sustainable than Case 2 during this operational phase. It is because increment of generative empower (TI_s) due to reinforced wall insulation is greater than the loss of empower during summer. Case 3 eventually obtains the greatest amount of H, F, L, and empower around the optimal level of AMI/H.

It should be noted that the fitness change remains stagnant despite an increase of resilience and complexity. This result strongly proposes that increasing complexity and resilience be an ultimate goal of building sustainability. Accordingly, it also demonstrates that defining complexity as a surrogate of potential power is desirable.

On the other hand, similarity between the H- TI_s profile (Fig. 5.5.11 (a)) and the H- H_i profile (Fig. 5.5.12) suggests that building operational phases are significantly affected by the energy and information content of imports, whereas the internal flow structure for utilizing external resources is an important factor in the whole system (Fig. 5.5.4). This is why H and L can stay high even though AMI increases; that said, the AMI-L and AMI-H plot indicate that buildings may lose H and L suddenly, if network organization becomes too weak.

5.5.3.3 Envelope: Annual (life cycle analysis)

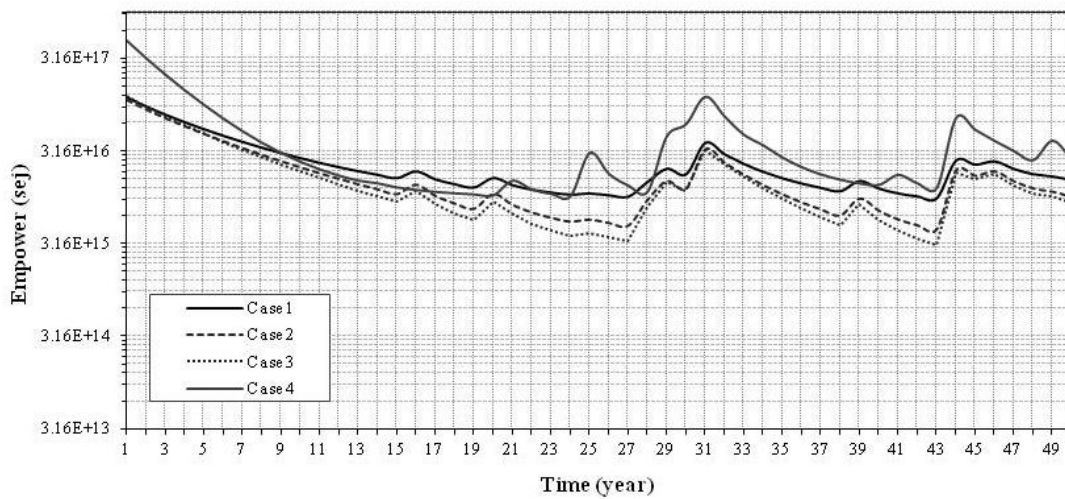

(a) Annual variation of degenerative empower

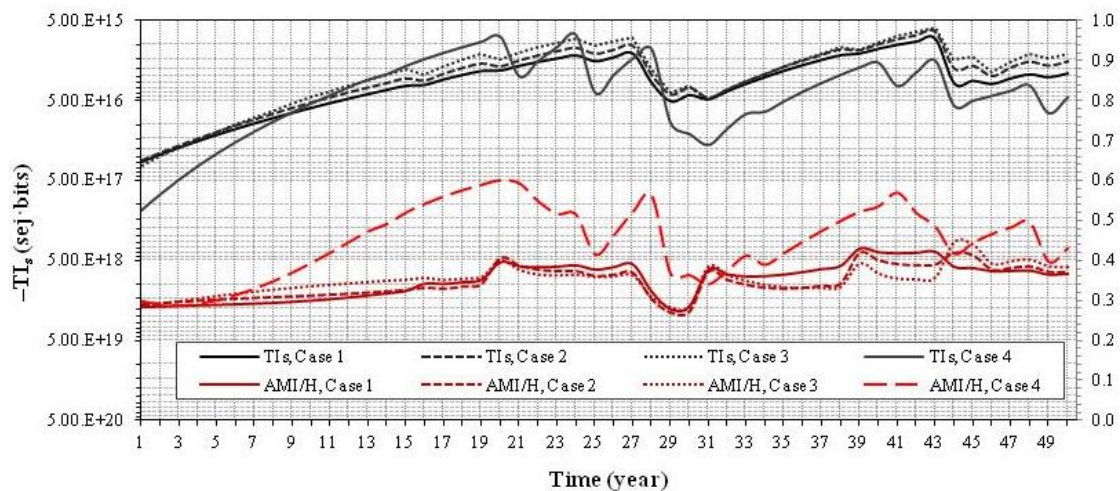

(b) Annual variation of total system information (TI_s)

Fig. 5.5.13 Empower profiles of test buildings (envelope), life-cycle analysis

Case 4 (NZEB envelope) consumes a larger amount of nonrenewable sources for manufacturing and, therefore, it is more degenerative (Fig. 5.5.13 (a)). TI_s evaluates the generative aspect of empower. Fig. 5.5.13 (b) presents the profiles of empower (TI_s) and efficiency (AMI/H). This shows that test cases grow and develop, like ecosystems, with the acquisition of TI_s . It is very important to note that Case 2 and 3 tend to reach the optimal level of AMI/H (0.37) when TI_s is maximized. This result clearly suggests that the occupants-driven operation of building form performs like an ecosystem, which follows maximum power principle.

Fig. 5.5.14 also supports an ecosystems understanding of building performance. In Fig. 5.5.14 (a), complexity (H) increases with an increase of TI_s . The phenomenon that a sharp increase of TI_s leads to a slight increase of H indicates that buildings under the early stage (before the 27th year after construction) focus on the growth. A sharp increase of H with relatively small changes of TI_s means the buildings rapidly self-organize and develop internally. Fig. 5.5.14 (b) and (c) suggest that efficiency of Case 2 and 3 tends to be compromised at an optimal level according to an increase of generative inputs. Efficiency of Case 4 (NZEB), however, continues to increase beyond an optimal value. In Fig. 5.5.14 (d), a decline in the resilience of Case 3 shows that ecological growth can sacrifice resilience, but it gradually increases during developmental phases.

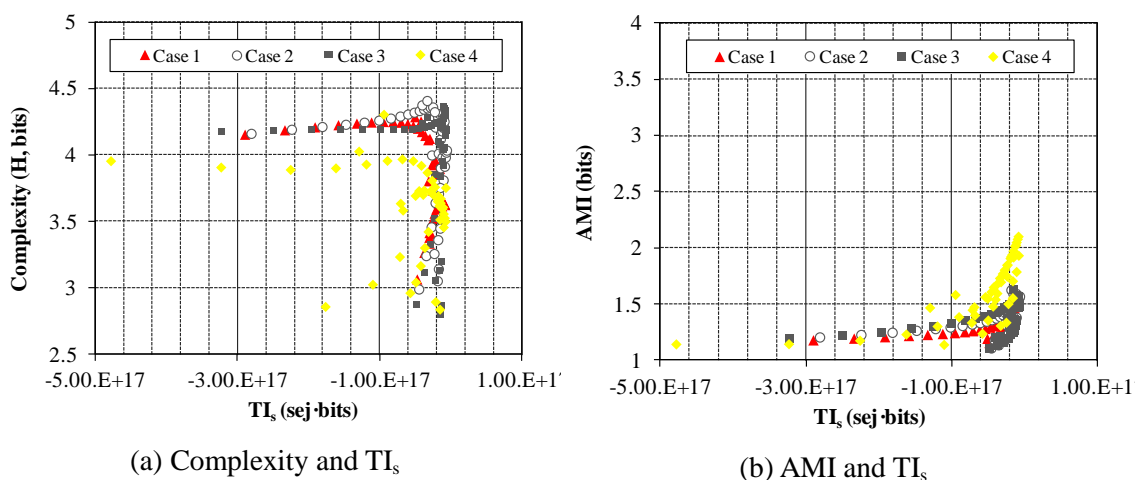

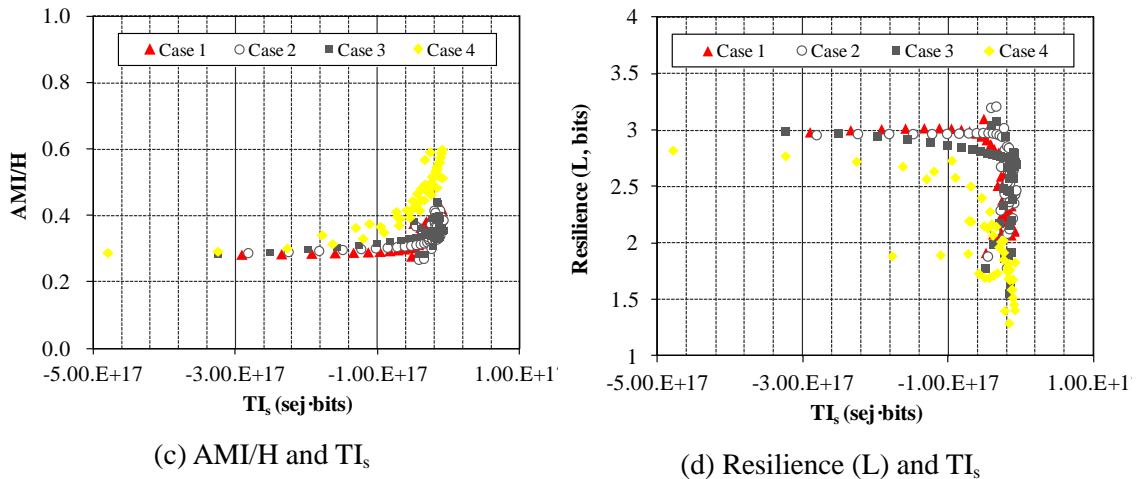

Fig. 5.5.14 Empower profiles of test buildings (envelope), life-cycle analysis

The F-L plot in Fig. 5.5.15 reveals that the NZEB is less adaptable and robust. A continuous increase of resilience and complexity at the high level of fitness suggests that they are more ultimate goals of building performance in association with increasing empower. The F-AMI/H plot clearly indicates that the energy-networking pattern of Case 4 is more structuralized for the efficient transfer of resources and, thus, weak at external perturbation, whereas Case 2 and 3 are more flexible. The relationships between H and AMI are approximately consistent with maximum power principle; nevertheless, points are dispersed and the relationships are not clear. On the other hand, comparison between H- H_i plots in Fig. 5.5.4 and 5.5.15 explains that the building form is more to do with the information of external inputs and outputs than the whole building system.

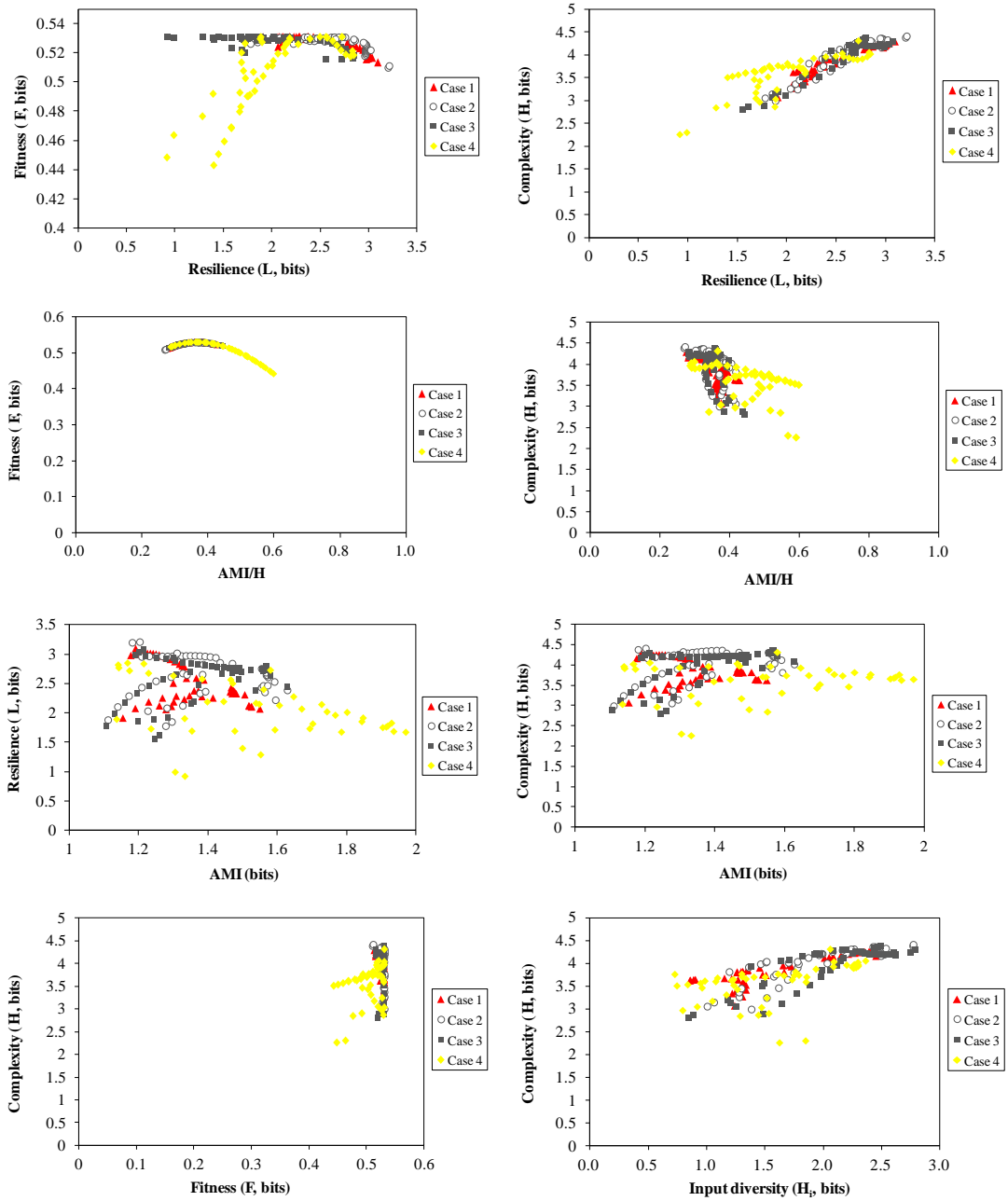

Fig. 5.5.15 Phase plots of information indices (envelope), life-cycle analysis

CHAPTER 6

CONCLUSIONS

This dissertation proposed a new method and new indices for the evaluation of environmental building performance through an eco-systemic understanding of building thermodynamics. The goal of this study was to complement the limit of the current mechanistic, reductive framework of building sustainability assessment that cannot clearly explain the final cause of building's environmental functioning at a macroscopic level. To this end, this dissertation proposed a system-level performance evaluation methodology with the development of an emergy-information integrated computation algorithm. Intensive network-pattern analyses in the proposed methodology account for the relational aspects of various energetic phenomena and internal trade-off/synthesis effects within a building. Throughout the study, buildings were defined as self-organizing systems that were supposed to follow the second law of thermodynamics and the maximum power principle in dynamic relationships between building energy use, material consumption, and the occupant's behavior. This perspective provides a rationale for the characterization of a building model with a stochastic thermodynamic flow organization. Building subsystems and elements that affect quantity and quality of energy, material, and services were identified and assembled into eight system components to establish a nodal flow network. And, by doing so, attempts were made to quantify the internal thermodynamic flows of the cardinal ecosystem constituents (energy, material, and information) in an emergy equivalent. Use of emergy to measure flow quantity is conducive to monitor global environmental changes with the building system (local) observation. In this evaluation framework, building sustainability depends on a probabilistic description about the configuration of systemic emergy flow networking, which is translated into building's ecological attributes such as the potential of evolution (self-organization), adaptability, and/or system's invulnerability (robustness) to unexpected events from the environment. Building information content measured with emergy provides a holistic measure of building performance immediately applicable to building design and/or design-decision making, since it integrates design factors of different types and scales.

This ecological network-based approach to the building performance evaluation was justified with demonstration of the hypotheses (as supposed in Chapter 1). Evidence found in the test-case experiments indicates a number of useful observations and conclusions: (1) each environmental input has different thermodynamic quality whose organization into a built form situates the building within the energetic hierarchy of the global environmental system; (2) a stock-based evaluation (energy, energy analysis, etc.) may not correctly describe building sustainability, since buildings go through dynamic variations of the energy flow structure even under the same energy/energy use; (3) greater nonrenewable or renewable inputs do not necessarily ensure sustainability unless information is considered as a substantial environmental source; (4) system power and uncertainty (complexity) of the network configuration (H) are complementary to each other, and complexity is a proxy of power and sustainability is ensured by complexity increment; (5) increasing power, resilience, and fitness are a common phenomenon of sustainable buildings, any evidence of ecosystem development; (6) climate-responsive adaptation through the occupant's behavior increases system resilience and robustness, which increases sustainability; (7) building form is a dominant player in determining building performance, for it carries the greatest information among building system components.

From the above findings, it can be said that buildings form by self-organizing environmental sources (including information) according to environmental conditions, thereby eventually accumulating information content. Therefore, greater information in the building form leads to greater empower that is also helpful for gaining a competitive advantage in environmental persistence.

The proposed methods and experimentation highlight bioclimatic adaptation of the building construction, operation, and maintenance, that priority should be given to increasing the information content of the building form (envelope) and thermodynamically positive human behavior. In particular, occupants' activities based on knowledge become an important provider of the building information content as an environmental source.

An environmental stress that causes system behavior to increase resilience may not necessarily be consistent with power maximization. Comparing information analyses of different time frames, short-term pulsing of information content and energy values (monthly or hourly oscillation) showed that the buildings keep

adjusting system properties flexibly according to temporal variations of the internal/external environment. Nevertheless, life cycle analyses revealed that overall system's internal tendency is directed toward increasing the power and resilience simultaneously in the long run.

Strengths

Elaborations of energy network properties have a great deal of merit because they have the potential to clarify cross-correlations of building design parameters and trading-off effects in the application of multiple green building design strategies, which has brought controversy in decision-making in design and managerial processes. By examining behaviors of energy flow organization at the overall system level, sensitivity, influence, and dependency of each building element and performance of design actions are elucidated and awareness of the final goal of building system functioning, namely, ecological maturity of our global environment, give us a clear direction of sustainable development and environmental building design.

To summarize major advantageous aspects of this dissertation,

- (1) Energy-information integrated algorithm: An information measure synthesizes different scales and types in quantitative terms, and energy evaluates the embodied environmental impact incorporating all physical/non-physical inputs at the geobiosphere level, which indicates system performance more sensitively than energy. However, energy is a donor-side measurement, and does not consider downstream impact in general. Thus, energy integrated with the symmetrical feature of information-based calibration allows us to measure both upstream and downstream impact comprehensively.
- (2) System-level building analysis: Building performance measured in a global ecosystem dimension informs a holistic degree of building sustainability that ensures the sustainability of geobiosphere. Also, evaluation of intensive aspects of building performance is very useful to identify robust transmission and organization of environmental resources through the built form.
- (3) Benefit of information theory definition: The essence of information is interactive feedback between system constituents, so it imparts a powerful framework to measure

trade-off effects of a building management action and human engagement.

Limitations

For correct interpretation of the energy-information-based building performance, justifiability of this approach is guaranteed only with clear awareness of the following weakness.

(1) Limit of the modeling: While the current performance evaluation models are mostly mechanical, deterministic to deal primarily with energy flows, proposed ecosystem-based modeling is necessarily spontaneous and stochastic to some degree, for it should include nonphysical fluxes (e.g., social, cultural) that are under uncertainty. So, oftentimes, performance measurement probably needs to be narrowed to examining energy and material transfers.

(2) Data refinement and precision issues: Application of information indices is strongly subject to data availability, data quality, and data requirements. Moreover, the stochastic feature of information indices sets a limit, as all statistical estimates and experimental data have limitations. Results are sometimes obtained from a meta analysis of datasets from previous studies. Elaborations to secure reliable data must be a crucial concern.

(3) Information content is highly dependent upon the definition of system boundary, component, and design. Even though this dissertation suggested a clear building analysis boundary and system design, and queries with another building system definition could leave vagueness of the presented system observation. In this respect, one should remind that informational measures do not distinguish goodness of resources

(4) Another unresolved problem is that we do not know capacity and transformity of building information sources due to its large variability and diversity. This gives a lot of uncertainty in building energy and triggers confusion in application of the maximum power principle. In this sense, experimental findings of this study need to be clarified further with discussions over those issues.

(5) Problems in direct application of maximum power principle: Maximizing power describes a common phenomenological tendency of ecosystem. So, there is no clear threshold on the level of maximization. For this reason, decision making may be biased, since buildings are technically not a natural system.

Contributions and future work

Despite the pros and cons, at the end of the day, the new framework suggested in this dissertation contributes to an extended understanding of building sustainability that reveals ecosystem-level building performance that has been underestimated in the architectural discipline. This systematic approach is also a paradigm-shifting proposal to defining environmental architecture. It characterizes the building not as an indiscrete energy consumer but as a positive environmental agency, which emphasizes potential connection for the circulation and production of useful resources through buildings. Measurement of building performance in conjunction with ecosystem quanta (energy, matter, and information) enabled to suggest an underlying principle that incorporates complex aspects of the building's macroscopic operational mechanisms. A new methodology and experimental exploration presented in this dissertation contributes to the study of environmental building accounting methods, and, more importantly, provides an insight for architects to design a new type of environmental architecture. Major contributions can be summarized: (1) characterization of building energy processes and environmental functions as a channeling communication of environmental resources that incorporates energy, material, human work, technology, and natural processes; (2) redefining building performance as its contributable capacity to the consistent development and evolution of the global environment; (3) suggestion of an energy-integrated information unit (bits) as a performance measure and super holistic index of building sustainability.

In addition, this dissertation also contributes in part to ecosystems theory by providing empirical evidences that phenomena of building system development are in parallel with those of ecosystems (increasing power, self-organization, adjustment of efficiency, etc.).

For future study, it should be noted that ecosystems do not obey the rule strictly. Demonstrations necessarily rest upon phenomenological observations. To give greater scientific rigor to the arguments of this dissertation, more case studies should be carried out. Furthermore, behaviors of building occupants or more complicated internal energy flow through spatial layout design also can be considered as a major target of resilience evaluation, as discussed that a magnitude of system complexity (H) indicates the potential of power and sustainability of the systems.

APPENDIX A Shanon's theorem

If X and Y are discrete random variables, and marginal information entropy of X and Y are $H(X)$ and $H(Y)$, joint information entropy is defined by:

$$H(X, Y) = - \sum_{i \in X} \sum_{j \in Y} P(x_i, y_j) \log P(x_i, y_j) \quad (\text{A.1})$$

And conditional information entropy is given by:

$$H_X(Y) = - \sum_{i \in X} \sum_{j \in Y} P(x_i, y_j) \log p_{x_i}(y_j) \quad (\text{A.2})$$

$$H = \sum_{i, j} P(x_i) p_{x_i}(y_j) \log p_{x_i}(y_j) = P(x_1) \sum_j p_{x_1}(y_j) \log p_{x_1}(y_j) + P(x_2) \sum_j p_{x_2}(y_j) \log p_{x_2}(y_j) + \dots \quad (\text{A.3})$$

From arithmetic treatment, the following relationship is introduced:

$$H_X(Y) = H(X, Y) - H(X) \quad (\text{A.4})$$

Redundancy (\mathbf{R}) is an information indicator that represents a degree of structural pre-determination; i.e., loss of uncertainty. It is computed as:

$$\mathbf{R} = \frac{H_{\max} - H}{H_{\max}} = 1 - \frac{H}{H_{\max}} \quad (\text{A.5})$$

APPENDIX B Conversion of Fisher information formula to the discrete expression

The general formula of Fisher information for discrete random variables is,

$$F(X|\theta) = \sum_i \left[\frac{\Delta p(x_i|\theta)}{\Delta \theta} \right]^2 \frac{\Delta x}{p(x_i|\theta)} \quad (\text{B.1})$$

In Eq. (2.9), let $p(s)$ be replaced with a substitute $q^2(s)$. This substitution does not only

simplifies Eq. (9) but also make the magnitude of errors more visible by amplification, such that:

$$\frac{dp(s)}{ds} = 2q(s) \frac{dq(s)}{ds} \quad (\text{B.2})$$

Introducing Eq. (B.2) to Eq. (2.9) gives,

$$F(s) = \int_s 4q(s)^2 \left[\frac{d}{ds} q(s) \right]^2 \frac{ds}{q(s)^2} = 4 \int_s \left[\frac{d}{ds} q(s) \right]^2 ds \quad (\text{B.3})$$

The differential terms are approximated with discrete variables of a certain threshold such that: $ds \cong \Delta s = s_{i+1} - s_i$, $dq(s) \cong \Delta q(s) = q(s)_{i+1} - q(s)_i$, where s_i is an index of i th system state, and $q(s)_i$ is the square root of the probability of the system being in the i th state. Hence, Fisher information is approximated as,

$$F(s) \cong 4 \sum_{i=1}^n \left[\frac{q(s)_{i+1} - q(s)_i}{s_{i+1} - s_i} \right]^2 (s_{i+1} - s_i) \quad (\text{B.4})$$

By spacing a unit apart such that $s_1=1$, $s_2 = 2$, $s_{i+1} - s_i$ becomes 1. Finally, we obtain,

$$F(s) \cong 4 \sum_{i=1}^n [q(s)_{i+1} - q(s)_i]^2 \quad (\text{B.5})$$

where n is the total number of states.

APPENDIX C Batty's Spatial entropy (Batty, 1974)

In Eq. (2.6), consider that the Boltzmann constant is 1, and p_i is replaced by $p_i(x)\Delta x_i$ where Δx_i is a unit of discrete interval over the continuous range of the variable. To obtain the continuous form of Shanon index, we let Δx_i be an infinitesimal value, and then Eq. (2.6) becomes,

$$\mathbf{H} = \lim_{\Delta x_i \rightarrow 0} - \sum_{i=1}^n p_i(x) \Delta x_i \log(p_i(x) \Delta x_i) \quad (\text{C. 1})$$

$$\mathbf{H} = \lim_{\Delta x_i \rightarrow 0} - \sum_{i=1}^n p_i(x) \Delta x_i \log(p_i(x)) + \lim_{\Delta x_i \rightarrow 0} - \sum_{i=1}^n p_i(x) \Delta x_i \log(\Delta x_i) \quad (\text{C. 2})$$

$$\mathbf{H} = - \int p(x) \log p(x) dx - \lim_{\Delta x_i \rightarrow 0} \sum_{i=1}^n p_i(x) \log(\Delta x_i) \Delta x_i \quad (\text{C. 3})$$

If it is assumed that $\Delta x_1, \Delta x_2, \dots, \Delta x_n$ are equal, the second term of Eq. (C.3) is reduced so that it becomes,

$$\mathbf{H} = - \int p(x) \log p(x) dx - \lim_{\Delta x \rightarrow 0} \log(\Delta x) \quad (\text{C. 4})$$

Eq. (C.4) demonstrates that Shanon information sets the limitless bound due to $\lim_{\Delta x \rightarrow 0} \log(\Delta x) \rightarrow -\infty$

Back to Eq. (C.3), replacing the left-hand side with Eq. (2.6) and simplifying $p_i(x) \Delta x_i$ with p_i gives,

$$- \int p(x) \log p(x) dx = - \sum_{i=1}^n p_i \log(p_i) + \lim_{\Delta x_i \rightarrow 0} \sum_{i=1}^n p_i \log(\Delta x_i) \quad (\text{C. 5})$$

$$\mathbf{H} = \lim_{\Delta x_i \rightarrow 0} - \sum_{i=1}^n p_i \log\left(\frac{p_i}{\Delta x_i}\right) \quad (\text{C. 6})$$

Eq. (C.6) is the information for the spatial analysis.

APPENDIX D Theoretical approach to quantitative evaluation of the sustainability: Thermodynamic dimension of building systems and a trend line of

global resource depletion (FROM THE LIMITS TO GROWTH)

Jørgensen (1992) emphasizes “absolute openness” is a defining characteristics of an ecosystem. From the point of view of thermodynamics, the building is identified as an *open* system because it exchanges energy and mass with its surroundings, and it is *dissipative* due to the fact that absorbed high-grade (low-entropy) energy is drained away while in operation into the ambient environment of high-entropy. It is also certainly a *non-linear*, because the transferred energy feeds back the building itself and larger social/technological communities by the occupants’ activities and material recycling. All these physical features converge into a single thermodynamic statement—a building is a system of being far from equilibrium state, namely, *non-equilibrium system*.

The SLT defines the final universal state of all systems activities, namely, a “global attractor state”, thermodynamic equilibrium. A state of a system—the distance from the thermodynamic equilibrium— informs the system’s potential of endurance against decay. Thus, the thermodynamic state is strongly associated with the system’s life cycle. The degree of the system’s persistence, *thermodynamic potential* or *power*, can be indicative of its sustainability. In other words, in all physical, non-physical systems, the sustainability is crucially related to their own capability of moving away from thermodynamic equilibrium, and, thus, quantification of building sustainability becomes a task of identifying the thermodynamic potential of the building system as a whole.

In thermodynamics, system’s potential is evaluated quantitatively with (available) energy stored within the system boundary, and characterized by the entropy (S). The entropy change (ΔS) of a system can be generally expressed as,

$$\Delta S = \Delta S_e + \Delta S_i \quad (D.1)$$

where ΔS_e denotes the entropy exchange with external environment through the system boundary, and ΔS_i is internal entropy generation due to irreversible processes. The SLT states that ΔS_i must be greater than or equal to zero, and thus, in isolated systems ($\Delta S_e = 0$), the system ultimately comes to an end by spontaneous degradation. Since the external flux (ΔS_e) can be either negative or positive, the system can

maintain or be developed into a non-equilibrium state ($\Delta S \leq 0$) by compensating the entropy increase (ΔS_i). Although open systems are always time-dependent, for equilibrium states or systems shifting steadily from one state to another ($\Delta S/dt \approx 0$), the entropy change can be estimated and formulated with internal and external variables³⁶.

However, except for the special case of the diffusive energy transfer, the non-equilibrium thermodynamics, which deals with the systems going through hardly expectable fluctuation (progression and reduction), is not in the realm of the exact science, because the external fluxes (ΔS_e) are so varying, and there is no general law or axiomatic state equations to describe the non-equilibrium system (Moran and Shapiro, 2000). For this concern, Massieu function for non-equilibrium states is insightful to render a general concept of system properties for the building sustainability science. The central concept of the function is that a system state can always be described with coupling of external and internal variables. In Chapter 1, we identified three elements of building's energetic organization such as (i) energy, (ii) matter (mass), and (iii) information. Each of which is a variable characterizing the system states, and represented with a finite set of sub variables. Let notations of the three primary state variables be E, M, I , respectively in sequence. And they, like of the thermodynamic systems, are categorized into two groups according to the scale of system definition. Then, a system state (S_{sys}) can be written using the Massieu formula as,

$$S_{\text{sys}} = \Psi(E_{e,1}, E_{e,2}, \dots, E_{e,l}, M_{e,1}, M_{e,2}, \dots, M_{e,m}, I_{e,1}, \dots, I_{e,n}, E_{i,1}, \dots, E_{i,p}, M_{i,1}, \dots, M_{i,q}, I_{i,1}, \dots, I_{i,r}) \quad (\text{D.2})$$

where $l, m, n, p, q,$ and r are the number of each variable, and the subscript e and i denote extensive and intensive variable. This equation implies every exchangeable properties and all information about the system's quantum transport.

This system state value is the index of building sustainability. Meanwhile, we have seen the general formulation of building sustainability (Eq. (2.1)), and the dual

³⁶ For equilibrium or quasi-equilibrium systems, the following expression is generally used for system state description; $dU = TdS - PdV$, where $U, T, P,$ and V are internal energy, temperature, pressure, and volume.

level of the analysis (extensive and intensive) depending the system definitions. So, by understanding the system state function(Ψ) with conjugation of sub functions, the measure of building sustainability (B) can be developed again by analogy to the Eq. (3.2) such as,

$$\mathbf{B} = \mathbf{f}(E_e, M_e, I_e) \otimes \mathbf{g}(E_i, M_i, I_i) \quad (\text{D.3})$$

where the function value \mathbf{f} and \mathbf{g} refer to extensive and intensive state respectively. Compared to Eq. (2.1), \mathbf{f} and \mathbf{g} correspond to \mathbf{C} and \mathbf{I} . Extensive (\mathbf{f}) and intensive function (\mathbf{g}) must be synthesized to represent a complete sense of sustainability, however, mathematical rigor of the relationship has not been able to be induced for now. So, tentatively, employing an arbitrary arithmetic operation (\otimes) for the conjugation, the degree of sustainability is represented as Eq. (D.3). This operator and unit of the measure will be identified with the ecosystems' characteristics of thermodynamic interaction and system networking.

To recapitulate Eq. (D.3) in terms of thermodynamics, the first term, \mathbf{f} , denoting capacity of through-flows, is the quantity of resource use and energy transformation work imposed upon the building system boundary. It can be referred to as extensive heat flows of the building system which could be reduced by cutting off the size of the building. On the other hand, \mathbf{g} , a function of a collection of intensive variables, relates indication of the sustainability to the system's energetic mechanism inside the boundary; i.e., it implies the internal response to the variation of the external quantity and energy transformation in a number of sub-processes. Since it primarily deals with the overall configuration of the system's energetic process such as the pathway structure of energy and material, this intensive term is less affected by the size change. Once we notice that a building is an evolving system in part or whole, a result of cultural development, \mathbf{g} is the measure of a spontaneously emerging pattern of the macroscopic system organization.

In general, change of extensive quantity drives that of intensive attributes (e.g. putting on pressure increases gas temperature). Open systems release and absorb energy, matter, and information; and that transfer eventually takes on the agitation of the molecular particles (quanta). The fluctuation of the system status due to the quantum fluxes pertains to the "rate of processes" at which the system work. In non-

equilibrium physical systems, the extension of Massieu function yields,

$$Y_i = \frac{\partial S(X)}{\partial X_i} \quad (\text{D. 4})$$

where Y_i is i th internal variable of a system, and S is entropy, a function of external variables (X). This equation clearly shows that internal variation depends on the external change. Consider building processes are open to dynamic sources (e.g., solar radiation, human behavior, weathering of construction materials, etc.), and, hence, always dependent on time intervals. To account for this dynamic feature, introducing time (t) to Eq. (3.4) gives,

$$Y_i/dt = \frac{\partial S(X)}{\partial X_i dt} \quad (\text{D. 5})$$

Based on Eq. (3.5), the relationship between f and g can be led to,

$$g/\Delta t \propto \Delta f/\Delta t = \Delta(f/t) \quad (\text{D. 6})$$

Notice that f is a function of independent variables. Eq. (D.6) is not a strict translation of the Eq. (3.5), but yields a very useful insight that g does not depend on a static value of f , but the rate of its change, *gradient*.

Eq. (D.5) demonstrates the internal organization of the building system is constrained to some extent by the gradient of external perturbation. However, still in question is how the pattern is emerged and organized by the intensity of the induced variation, and whether there is a deterministic direction, and, if any, what the direction is. Schneider and Kay (1994a,1994b) answer this inquiry with an interesting experiment of a simple non-equilibrium thermodynamic device called Bénard cell. They tested a device filled with silicon oil between two different heat reservoir placed in parallel on the top and the bottom. Recording temperature profile and entropy production of the working fluid, they noticed that, as the external heat transfer rate to the oil increased due to the reservoirs' temperature difference, a complex pattern of the temperature profile was emerged, and more entropy was produced. This

experiment demonstrates the faster the external forces vary, the more internal variables develop a complex system organization. Another similar example is Couette flow of fluid dynamics. Suppose stable liquid flow enclosed between two plates that can only move in opposite directions. A quick motion of the plates imposes a large amount of shearing force on the flow boundary, and, thereby, it transforms the laminar flow into vortex and turbulence in the inside layer, which are enormously complex to expect and measure.

Above two cases succinctly demonstrate that any system, for both physical and animate system, shifting towards non-equilibrium states attempt to adjust the effect of external perturbation by spontaneously organizing an internal structure. The systems under a certain external force resist to the applied gradient, and strive to offset the influence of the external stress by augmenting the internal complexity. “*Self-organization*” happens while in trading off the system’s internal inertia and adaptation to the changed environment.

Buildings are exactly under this universal thermodynamic rule for open systems. Consider a simple cabin house in hot climate. If conduction with no air infiltration is the only way the outside heat is transported, the house may well get overheated soon, and temperature of the indoor areas rises higher than the outside. Not surprisingly, an occupant will open windows to lower the temperature difference. As a consequence, the house system has a new heat flow path, and quantity of heat flow is distributed accordingly.

This example proves the outside thermodynamic constraint has created more complex pattern of energy dissipation, as well as an order of the building system. This may falsify the Boltzmann’s argument that order is infinitely improbable (Swenson, 1997), but is fully consistent with the idea that order is unpredictability of information (Chapter 2).

Development of complexity in the building development

Now, discuss the aforementioned rule and formulation in far wider context of general building systems thermodynamic processes. The utmost basis of all the processes is our planet that is referred to as a global ecosystem (Odum, 1971; Meadow, 1972). It is regarded as a large thermodynamic system not isolated but closed to mass transfer (half-opened). Hence, buildings, a life-support system as part

of the large ecosystem, are essentially influenced by the quantity and transport of the geobiological resources. The carrying capacity of the external resources regulates the limit of all energetic exchanges, including cultural, social service, and monetary transactions, of the building systems which belong to socio-cultural subsystem. By aggregating schematically heterogeneous levels of the flows into a single flux³⁷, as depicted in Fig. D.1, a basic global thermodynamic process is obtained.

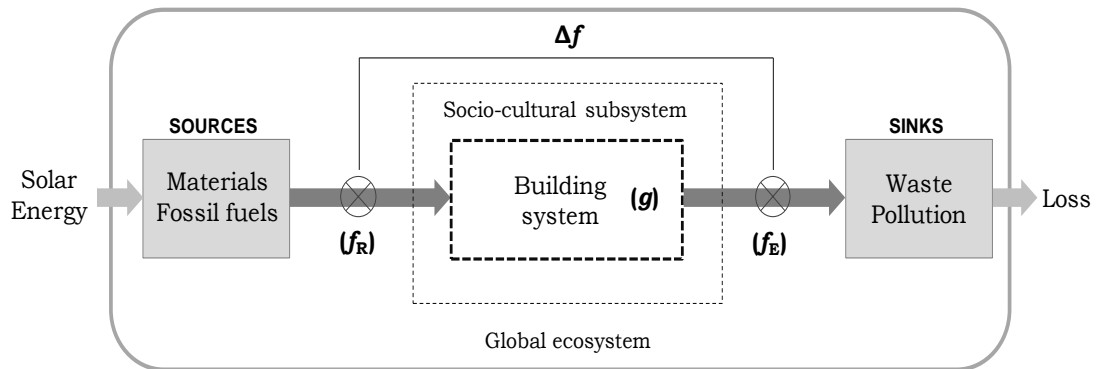

Fig. D.1 Thermodynamic mechanism and function of sustainability indicator: The earth is a closed system, but buildings are opened. SLT states that all systems in the universe have to be supplied from lower entropy sources to prevent cessation of life. If the definition of buildings is extended to the socio-cultural system, the three sources feed buildings; energy, matter, and information. They all become an energetic source to be deposited to organize a form of material and human behavior.

In Fig. D.1, we find that four lines of flows characterize the building system operation. Considering Eq. (D.3), The external carrying capacity function is subdivided according to the thermodynamic mechanism: a function of the resource capacity (f_R) and emission (f_E). Then, during a time interval, the pressure to trigger the internal changes is estimated with the rate of the difference of the functional values between the source and sink such as: $|f_R - f_E|/\Delta t$.

Note that the impact of the external forces imposed on the buildings depends on the elapsed time. Thus, a diachronic dimension for the long-term change of the flows must be considered to understand the general process in the real context. Fig. D.2 shows the results of D. Meadow and Rome club's record and simulated expectation

³⁷ Input of low entropy source is negentropy. Kelly (2011) proposes to use *exotropy* to embrace negentropy of all social, technological, and cultural services for human goals and system objectives.

about the global resource use and emission of waste and pollution to the earth. The exponential curve is the accumulated amount of nonrenewable source consumption (e.g., mineral, fossil fuel, etc). The curve ① indicates the energy demand and production to support our modern civilization have notably grown during the past century, and it is expected to be highly likely to reach the limit within the next one hundred years. To prevent it, the consumption rate must increase less or no greater than the rate of renewable sources' replacement for the exploited ones (Abel, 1998) (If it is possible, Daly's quasi-sustainable status becomes achievable (Bastianoni et al., 2009)). However, the current consumption rate of resources is rapidly and continuously increasing from 1 to 4% (Meadow et al., 2004). At the same time, the discharge rate has also been skyrocketing.

The difference between the consumption of energy and materials and the emission rate has been a thermodynamic pressure for the building system, and this external change has evidently changed the configuration of the buildings. For example, from 1900s to 2000s (including the energy crisis of 1970s), when the first upheaval of the stress appeared, we have noticed the emergence of complex modern buildings which is more complex than before. Dramatic innovations of building materials, equipments, construction technologies, and design methods have been composed physical system elements and occupants' behavior in a complex relationship to harness the global energy sources effectively.

This tendency has been continued until today; however, far more developmental transition is near at hand³⁸. The data indicates the maximum rate of change $(\Delta k_{if}/t)_{\max,1}$ is likely to happen approximately in the immediate future (t_1).

Then, how would this climax of instability affect our contemporary building system and the prevalence of the modern style in our civilization? The simulation based on the standard scenario —maintaining present human practices, not disturbing the current flow of energy, material, service, and goods— is based on the lifeboat model. The skepticism shows our system eventually faces the exhaustion of the resources, and reaches the equilibrium state. So, one immediate possible way to overcome the threat is conscious treatments and endeavor to reduce the ascending pressure of resource depletion and pollution (reduction of the consumption and emission). They surely delay the forthcoming stunning moment to decades later

³⁸ In 2004, Campbell expected global oil and fossil fuel production would peak around the present time (Campbell, 2004).

$(\Delta k_2 f/t)_{\max,2}$), and a considerable degree of change in the composition of the building system as well as actions and connections with the global society and culture would decidedly lead the system to a new non-equilibrium state enabling steady growth³⁹ of building (curve ②).

Along with the development of our society, the time period between t_1 and t_2 will be underpinning the greatest potential ever for the ecological evolution of the environmental building design. Drastic changes of the global ecosystem condition will strongly provoke appearance of far more complex architectural means of using energy and improving performance, whereby the composition of building system is undergoing the evolution, and organizing itself for the sustainable growth of itself and the global ecosystem.

However, ecosystems do not maximize their complexity indiscreetly, but optimize it decisively for effective metabolic energy transfer for development (Odum, 1994). Genetic information becomes dominant in such a regulation. Following sections describe thermodynamic mechanism of the building ecosystem at the intensive system level.

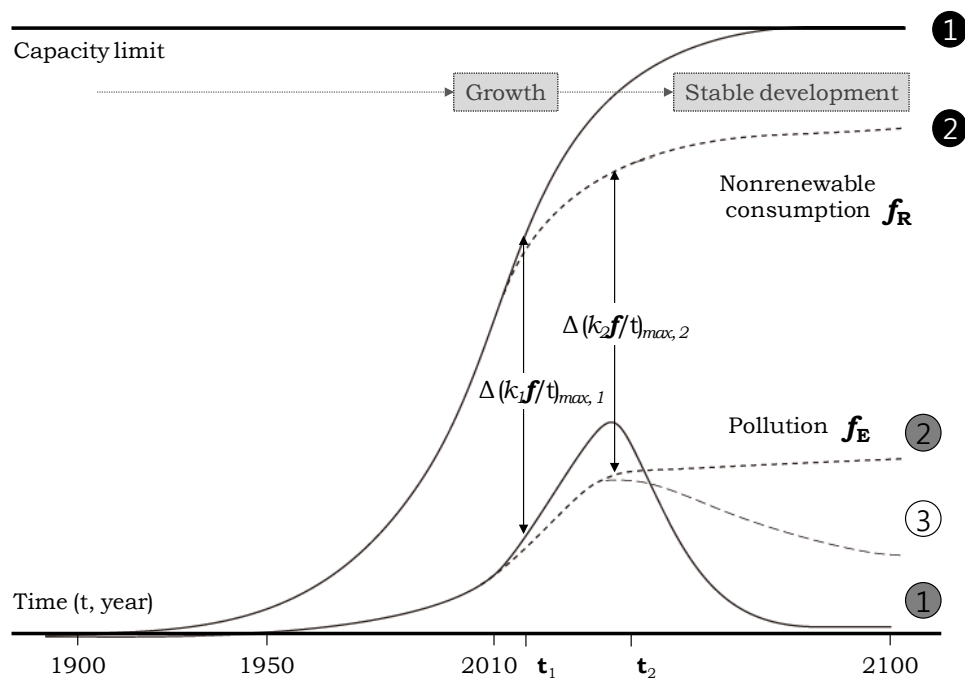

Fig. D.2 Temporal trend and scenarios of global resources depletion and emission of pollutants: Limit of growth and potential of the building system's dynamic change

³⁹ Development comes after an addition of new type of energy paths, whereas growth occurs when the system simply adds more of the same types of pathways (Toussaint and Schneider, 1998; Daly, 1990). In a biological sense, development is closer to the definition of evolution.

($k_1, k_2 > 1$) (Data source: Meadows and Club of Rome, 1972; Meadow et al., 2004) (①: simulation result based on standard run; building development reaches the growth limit, ②: stable growth scenario; building system maintains continuous growth, ③: recovery scenario; this is hardly expected in the near future.)

APPENDIX E Theoretical foundation and formulation of MPP

For linear nonthermodynamic systems, Onsager's theory formulates a general relationship between thermodynamic flux J_i (e.g., heat flow rate, molecular velocity) of the system and external thermodynamic forces X_i (e.g., temperature gradient) such as:

$$J_i = \sum_k L_{ik} X_k \quad (\text{E. 1})$$

This equation can be understood as a theoretical foundation of various empirical laws of continuum transfer (e.g., Fick's law, Ohm's law, etc.). So, L_{ik} is an empirical coefficient related to flows such as thermal conductivity or fluid viscosity. Onsager's reciprocity theorem gives $L_{ik} = L_{ki}$.

However, this formula cannot be applicable to dynamic equilibrium systems. Thus, introducing entropy production density (σ), the relation of flux and force is extended generally to:

$$\sigma = \sum_k J_i X_k \quad (\text{E. 2})$$

To understand above equation in a simple manner, Odum and Pinkerton (1955) apply it to a single inlet and outlet thermodynamic system. Then, Eq. (E.2) becomes,

$$\frac{TdS}{dt} = J_1 X_1 + J_2 X_2 \quad (\text{E. 3})$$

where T, S, and t denote system temperature, entropy, and time, J_1 and X_1 are flux and force of the input, and J_2 and X_2 are the attributes for the output. It is convenient to assume L_{ki} as a positive constant under a true dynamic system, and we estimate J_1 and

J_2 from Eq. (E.1):

$$J_1 = L_{11}X_1 - L_{12}X_2 \quad (\text{E. 4})$$

$$J_2 = -L_{12}X_1 + L_{22}X_2 \quad (\text{E. 5})$$

The negative sign convention for L_{12} is appropriate to represent efflux. Here, the power of energy transfer is J_1X_1 and $-J_2X_2$ for the inlet and outlet respectively. What we have to count for maximum power is the energy availability at the outlet. Let the input and output power P_1 and P_2 , and a certain parameter R represent the ratio of forces, X_2/X_1 . Then, R approximates the system's efficiency (E), since $|P_2/P_1| = J_2X_2/J_1X_1$. Consider our goal is to maximize the output power. Introducing Eq. (E.5) and R , P_2 becomes,

$$P_2 = L_{12}X_1^2 \left(1 - \frac{L_{22}}{L_{12}}R\right)R \quad (0 \leq R \leq 1) \quad (\text{E. 6})$$

Eq. (E.6) informs P_2 is maximized when,

$$R = \frac{1}{2} \frac{L_{22}}{L_{12}} \quad (\text{E. 7})$$

Eq. (E.7) show R becomes 1/2, if frictional attributes of the input and output pathways are the same ($L_{12}=L_{22}$). Finally, using Eq. (E.7), we get the efficiency at the maximum power as,

$$E_{[\text{max}]} = \frac{L_{12}^2}{4L_{11} \left(1 - \frac{L_{12}^2}{L_{11}L_{22}}\right)} \quad (\text{E. 8})$$

APPENDIX F-1 Reinterpretation of Odum's Atwood example

Odum (1955, 2007) presented as the simplest example of MPP the Atwood machine which is a common classroom demonstration used to illustrate principles of classical mechanics. As depicted in Fig. F.1, suppose a frictionless pulley system that

has two rigid bodies of mass m_1 and m_2 . Each of which moves at velocity of v_1 and v_2 , according to the mass balance. From a thermodynamic analogy of this physical system, X_1 and X_2 of Eq. (E.3) correspond to m_1g and m_2g , respectively, where g is gravitational acceleration. Then, the output power P_2 becomes v_2X_2 . The MPP problem can be written as an optimization problem with a constraint of energy conservation as follows:

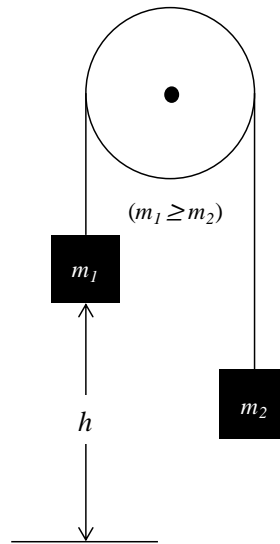

Fig. F.1 Atwood machine

$$\max \quad v_2 X_2 \quad (\text{F. 9})$$

$$\text{s. t.} \quad m_1 g h = m_2 g h + \frac{1}{2} m_2 v_2^2 \quad (\text{F. 10})$$

substituting the mass with the thermodynamic forces, Eq. (F.10) is rewritten as,

$$2X_1 h = 2X_2 h + X_2 g v_2^2 \quad (\text{F. 11})$$

accordingly, we get v_2 as,

$$v_2 = \sqrt{\frac{2h}{g}} \sqrt{\frac{X_1 - X_2}{X_2}} \quad (\text{F. 12})$$

Finally, the cost function is:

$$\max \sqrt{\frac{2h}{g}} \sqrt{X_2(X_1 - X_2)} \quad (\text{F.13})$$

From Eq. (F.13), it became clear that we obtain a maximum value when X_2 is $X_1/2$. Note that v_1 equals v_2 for this system, hence, the system efficiency (E) is the same as R which is 50% at the maximum power.

APPENDIX F-2 Demonstration of the relationship between efficiency and resilience measures: A double-compartment case (extended from Ulanowicz's exemplar experiment (Ulanowicz 1986)).

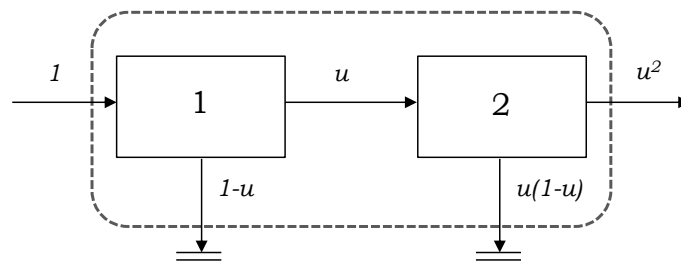

Fig. F.2 Configuration of a double-compartment system

Let us consider a simple system comprised with two compartments. Generally, each compartment represents an ecosystem of a trophic level or a system component. Denoting the efficiency of each compartment by u , total system flow throughput (T) is $2 + u$. Then, we can approximate functional relationships between the ascendancy (A) and capacity (C) such that,

$$A = (2 + u) \log(2 + u) + (u^2 - 1) \log(1 + u) - u^2 \log(u) \quad (\text{F.14})$$

$$C = (2 + u) \log(2 + u) - (2u + u^2) \log(u) + (u^2 - 1) \log(1 - u) \quad (\text{F.15})$$

From the above formulations, graphs in Fig F.3 correspond to the change of the

Ulanowicz's system indicators according to the change of the compartmental efficiency.

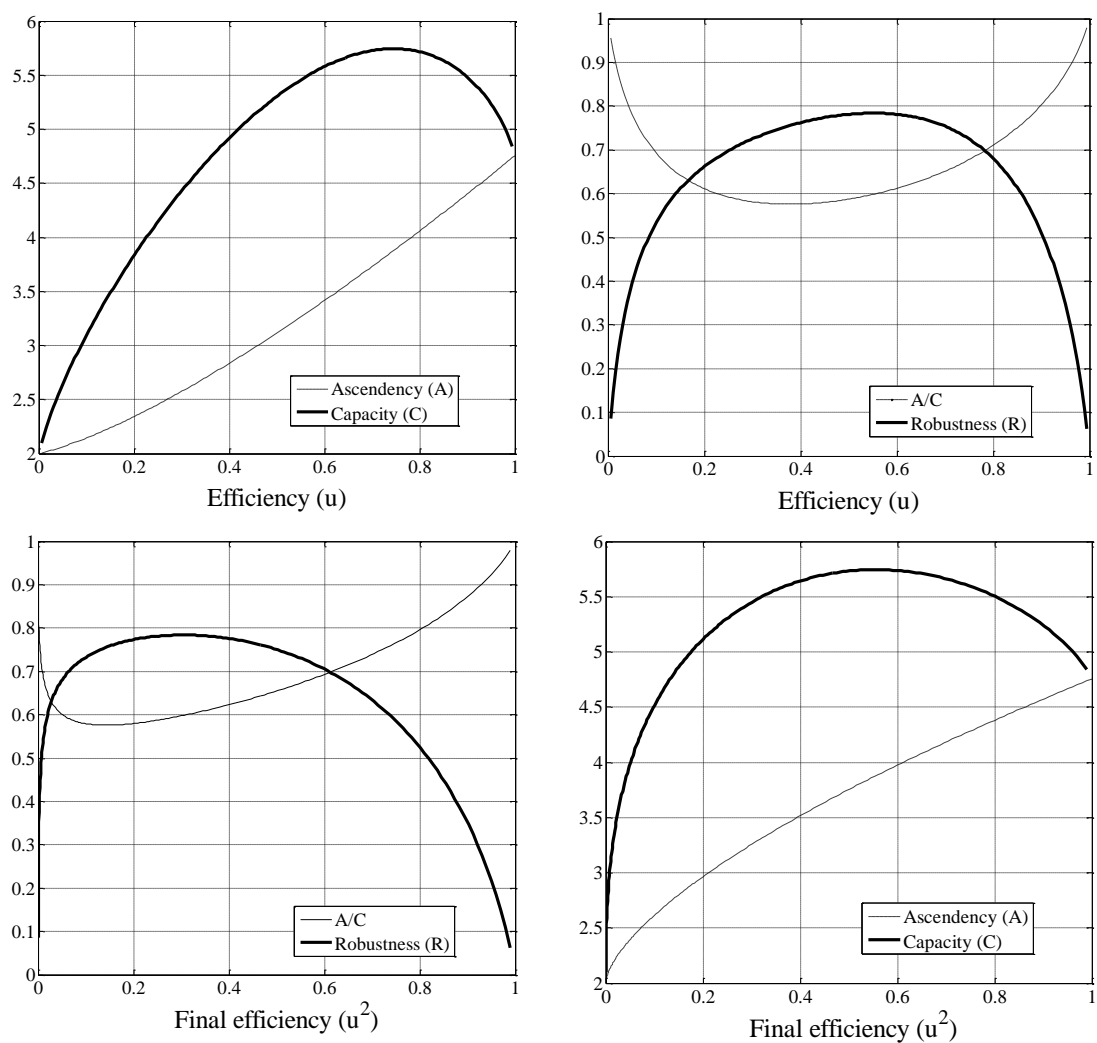

Fig F.3 Relationship between efficiency and system indicators: We can identify that system capacity and network efficiency (A/C) tend to maximize at an intermediate level of efficiency.

APPENDIX G Characteristics of a typical single-family home in the U.S.

Table G-1 Characteristics of a typical single-family home (U.S. DOE, 2012)

Year built	mid 1970s
Number of occupants	3
Stories	1
Foundation	Concrete Slab
Number of rooms	Bedroom
	3

	Other room	3
	Bath room	2
Window	Glazing type	Double-pane
	Number	15
	Area	11.5% of conditioned floor area
Equipment	Space and water heating	Central warm-air furnace (Natural gas)
	Space cooling	Central air-conditioner (Electricity)
Water use		185.5 L/day
Appliances	Refrigerator	19 cubic feet, 2-door type
	TV	3
	Computer	2
	Ceiling fans	3
	Range/Oven	Electric
Garage		2-Cars

APPENDIX H Inputs for the baseline energy simulation: Benchmarking reference to household energy simulation input data (end use) (Units of some equations were converted to refined to SI units. Original numeric data is available in a spreadsheet format at: <http://energy.gov/eere/buildings/building-america-analysis-spreadsheets> Accessed: 4.14.2015)

(1) To set up a baseline energy/environmental simulation model, the following benchmark data were used for model inputs based on the Building America House Simulation Protocols (BAHSP; Wilson et al., 2014). Throughout this protocols, the number of bedrooms (N_{br}) works as a surrogate of occupancy and human activities. The number of occupants is thus estimated as:

$$N_{people} = 0.59 N_{br} + 0.87 \quad (H.1)$$

Accordingly, for Building A (baseline), $N_{people} = 0.59 \times 4 + 0.87 = 3.23$. Eventhough Building B has only one bedroom in order to disply some energy-saving technologies, it was designed to model a typical single-family house. Therefore, we assume that N_{br} of Building B is the same as Building A.

(2) In the BAHSP, key parameters for the calculation of the baseline lighting loads are floor areas: FFA (finished floor area in ft^2) and GA (garage area in ft^2). Estimates are 0.8 (FFA \times 0.542 + 334) kWh/yr for all interior hard-wired, 0.2 (FFA \times 0.542 + 334 kWh/yr for all plug-in (luminaire), and GA \times 0.08+8 kWh/yr for garage lighting.

For Building A, GA is 374.7 ft², and FFA is 3292.9 ft² (total floor area – garage area = 3667.6 – 374.7). Hence, annual wired lighting load is 1695.0 kWh/yr (193.4 W), and the energy use for luminaire is 423.8 kWh/yr (48.3 W). Lighting load of the garage is 38.0 kWh/yr (4.3 W).

For Building B, GA is 334.2 ft², and FFA is 3063.9 ft² (total floor area – garage area = 3398.1 – 334.2). Hence, interior lighting fixture load is 1595.7 kWh/yr (182.0 W), and the energy use for luminaire is 398.9 kWh/yr (45.5 W). Lighting load of the garage is 34.7 kWh/yr (4.0 W). Radiant fraction of lighting fixtures is estimated as the average of suspended (0.42) and mounted type (0.72). The general visible fraction of lighting is 0.18

(http://www.designbuilder.co.uk/helpv3/Content/_General_lighting.htm).

(3) Electric equipment loads are calculated using the formulas listed in Table H.1, and the results are summarized in Table H.2. Meanwhile, Building A includes some gas equipment. Based on the BAHSP, it is assumed that a gas cooktop demands 2.64 + 0.88 N_{br} therms/yr and a gas oven consumes 0.44 + 0.15 N_{br} therms/yr and natural gas use of appliances in Building A is 82.12 BTU/h (0.76×10⁹ J/yr).

Table H.1 Estimation method of interior equipment loads

Category	Item	Calculation (kWh/yr)	Sensible load ^a	Latent load ^a
	Refridgerator	434	1.00	0.00
	Range	250 + 83 N _{br}	0.80	0.00
Major appliances	Dishwasher	87.6 + 29.2 N _{br}	0.15	0.05
	Clothes washer	38.8 + 12.9 N _{br}	0.60	0.15
	Clothes dryer	538.2 + 179.4 N _{br}	0.40	0.30
	Micellaneous ^b	1185.4 + 180.2 N _{br} + 0.3188 FFA	0.93	0.02

a. Fraction **b.** If ceiling fans are accounted for separately, 77.3 + 0.0403 FFA shall be subtracted.

Table H.2 Interior equipment loads for test buildings

Category	Item	Test building A and B (kWh/yr)
	Refridgerator	434
	Range	582
Major appliances	Dishwasher	204.4
	Clothes washer	90.4
	Clothes dryer	1255.8
	Micellaneous	2955.98
	Total loads	5522.58
	Average fraction of sensible/latent load	0.77/0.08

(4) Major inputs for mechanical equipment are as follows (Table H.3 ~ H.8). Specifications and efficiencies of mechanical conditioning systems are summarized in Table H.3, and set points are as shown in Table H.4.

Table H.3 Air-conditioning equipment (Building A and B)

Fuel	Function	Conditioning device
Electricity and natural gas (available on site)	Heating	78% AFUE gas furnace
	Cooling	13 SEER air conditioner (DX cooling)
All-electric (gas not available on site)	Heating/Cooling	7.7 HSPF/13 SEER air source heat pump

Note: HVAC efficiency conversion, SEER = EER/0.9 = 3.792 COP. For Ellis, known specifications of 93.7% AFUE and 12 SEER (3.162 COP) are used instead of the protocol. Power consumption of air handling units is 0.500 W/cfm.

Table H.4 Thermostat set points

Heating	71 °F (21.7 °C)
Cooling	76 °F (24.4 °C)
Dehumidification (relative humidity)	60%
Minimum Internal Temp for Natural Ventilation	72 °F (22.2 °C)

Table H.5 Air duct specifications

Duct surface area (ft ²)	One-story	Two-story or higher
Supply	0.27 FFA	0.20 FFA
Return	0.05 N _{returns} × FFA (Maximum of 0.25 FFA)	0.04 N _{returns} × FFA (Maximum of 0.19 FFA)

a. Primary duct material is sheet metal, b. The number of stories include basements for living space and finished attics. It is assumed that air leakage equals to 10% of air handler flows.

Table H.6 Domestic hot water (DHW) consumption and system

End use	Water temp.	Water use ^a	Type	Sensible heat gain ^c	Latent heat gain ^c
Clothes washer	Set point ^b	8.88 + 2.95 N _{br}	Hot	0	0
Dishwashers	Set point ^b	8.54 + 2.84 N _{br}	Hot	0	0
Shower	110 °F	52.92 + 17.65 N _{br}	Hot	785 + 261 N _{br}	745 + 249 N _{br}
Bath	110 °F	13.23 + 4.42 N _{br}	Hot/Cold	196 + 66 N _{br}	0
Sinks	110 °F	47.25 + 15.72 N _{br}	Hot/Cold	329 + 109 N _{br}	148 + 50 N _{br}
Total		130.82 + 43.58 N _{br}	Hot/Cold	1310 + 436 N _{br}	893 + 299 N _{br}

a. L/day, b. The nominal hot water set point shall be 125 °F, and 110 °F for mixed temperature, c. kJ/day

Table H.7 A benchmark DHW system

Fuel type	Natural gas
Tank location	Attached garage
Storage capacity	150 L
Efficiency	0.59
Recovery efficiency	0.76
Burner capacity	38000 kJ/h

Table H.8 DHW distribution characteristics

Branching configuration	Trunk and branch
Material	Copper
Pipe diameters	19.1mm (trunk), 12.7mm (branch)
Total pipe length (m)	111.56 + 0.04 (FFA – 2432) + 26.21 (N _{bath} – 2.85) ^a

a. FFA is finished floor area in ft², and N_{bath} is calculated as 0.5 (N_{br} + 1).

(5) Air infiltration and ventilation

The building space infiltration is closely related to air-tightness of a building shell, design of ventilation facilities, stack effect, and outdoor wind pressurization to the enclosure. No consensus of an air-infiltration standard for quantity and measure exists, and determination of infiltration rate is subject to significant uncertainty. The air change rate of a typical small residence may become far lower to be 0.05~0.1 ach. Even if the rate of a loosely constructed residence could be greater than 0.35. Referring to 2014 BA House protocols, the rated air leakage for a single-family home shall be:

$$ach_{50} \text{ (air change rate per hour)} = 7.0$$

This is an empirical result of an experimental pressure condition of 50 Pa. The protocol suggests the shelter coefficient to be 0.5 in order to describe a local context which outdoor airflow is “heavily shielded” by surrounding built-in objects. The ventilation rate at a natural state (generally at less than 4 Pa) can be computed approximately using a correction coefficient such that $ach = ach_{50}/20$ (Fennell and Haehnel, 2005), which leads to $7.0/20 = \mathbf{0.35ach}$ for the BA House protocol. For reference, in case of installing additional fans, the BA protocol proposes that fan power shall be 0.3W/cfm. (Alternative: ASHRAE Standard 62.2 –default infiltration for minimum ventilation requirement) Offermann et al. (2008) report that 75% of naturally ventilaed houses have air change rate lower than 0.35 ach. The protocol value is equal to the minimum requirement of fresh air intake suggested by ASHRAE 62.1-2001. However, it is a minimum value that is generally applicable to all types of spaces. BA house protocol assumes that the airflow shall be delivered by some combination of mechanical means and natural infiltration.

For the purpose of benchmarking metered data, no mechanical ventilation equipment is considered for the Ellis house energy modeling, even though the conditioning equipment has to accompany a ventilation system. Therefore, the air leakage rate is computed alternatively using ASHRAE Standard 62.2-2010 (a ventilation standard for low-rise residential buildings in U.S.).

ASHRAE Standard 62.2-2010 provides general methods to estimate the whole-house ventilation rate. First, it assumes that a default infiltration rate in cfm is $0.02 \times \text{Conditioned floor area (CFA, ft}^2\text{)}$. This simple estimate is refined by a formula such as $\text{CFA}/100 + 7.5 \times (\text{N}_{\text{br}} + 1)$. Another method is to use a prescriptive table as below. Total house ventilation rate shall be no less than any of the results from these methods.

CFA of Ellis house is 3039.5 ft^2 , the total air volume of CFA is 25497.5 ft^3 , and N_{br} is 4. Hence, the simple computation gives 60.8 cfm (0.14 ach), and the second formula method is calculated such that $3039.5/100 + 7.5 \times (4+1) = 67.9 \text{ cfm}$ (0.16 ach). Meanwhile, we get 90 cfm (0.21 ach) using the table method. As a result, we can assume that the leakage rate of Ellis house shall be greater than or equal to **0.21 ach**. This value is supported by that infiltration rates of typical U.S. residences is documented as 0.11 ~ 0.22 ach (Fennell and Haehnell, 2005).

Table H.9 Continuous whole-building ventilation requirement (cfm)^a

CFA (ft ²)	N _{br}				
	0 - 1	2 - 3	4 - 5	6 - 7	> 7
< 1500	30	45	60	75	90
1501 - 3000	45	60	75	90	105
3001 - 4500	60	75	90	105	120
4501 - 6000	75	90	105	120	135
6001 - 7500	90	105	120	135	150
> 7500	105	120	135	150	165

a. ASHRAE Standard 62.2 Table 4.1a

(6) Operating schedules and normalized daily profiles: Even though building operation schedules have much to do with simulation results, there have been no reliable references for single-family houses. Regarding this, BAHSP provides standardized daily profiles of small house's operation schedules. It is assumed that the building has 14 holidays during which the building carries no occupancy-related loads (vacation periods are defined as May 26~28, August 12~18, and December 22~25). Fig. H.1 illustrates the profiles on an hourly basis.

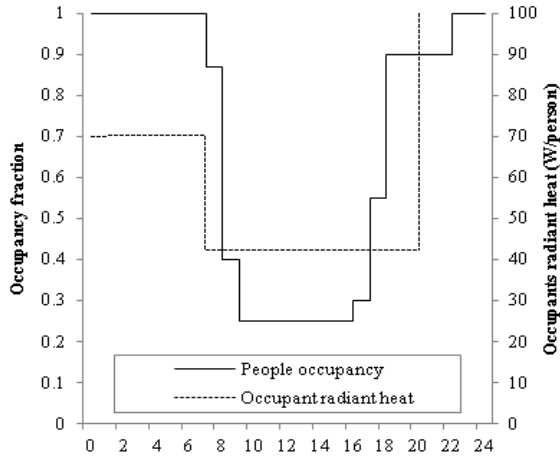

(a) occupancy

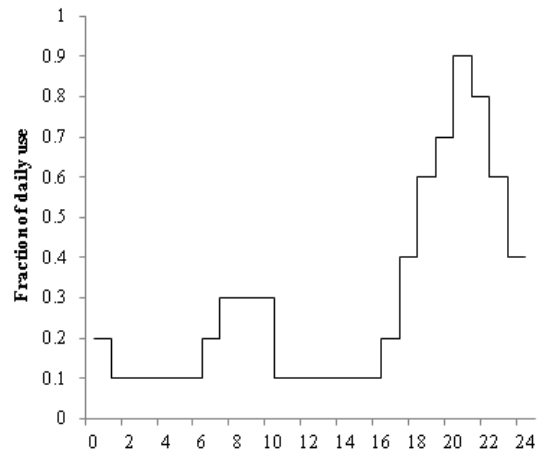

(b) interior lights

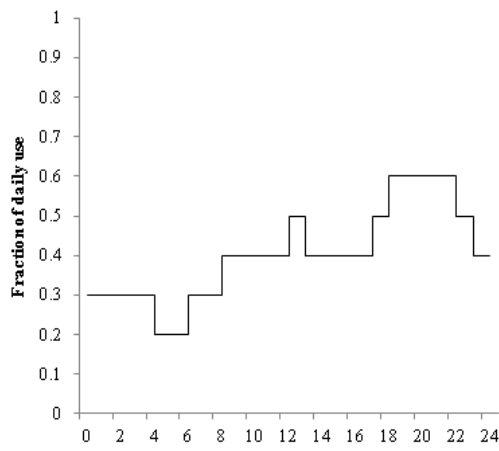

(c) electric loads

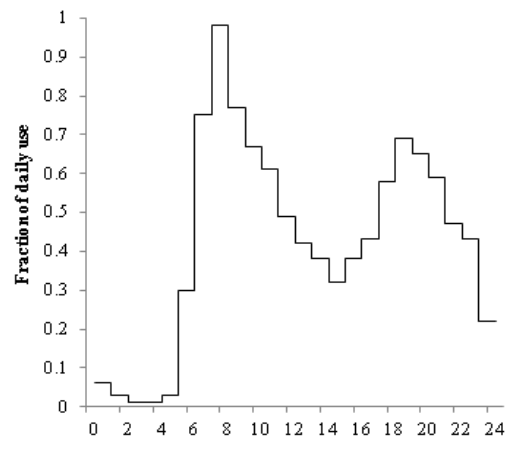

(d) hot water equipment use

Fig. H.1 Baseline building operation schedules

Table H.10 Calculation of environmental inputs to NZEB

Month	Rainwater collection (L)	Water use (L)	Water reuse (L)	Effective Wind hours (hr)	Wind turbine production (kWh)	Wind Emergy (E11 sej)	Solar Rad. (kWh/m ²)	PV Production (MWh)	PV Efficiency (%)	PV solar emergy (E10 sej)	Solar emergy for solar thermal system (E9 sej)
1	0	4854.6	2495.8	388	14.0	1.55	65.2	1.07	9.96	4.69	1.88
2	0	4384.8	2254.3	453	16.4	1.80	77.8	1.28	9.99	5.57	2.24
3	5000	4854.6	2495.8	401	14.5	1.60	107.3	1.76	9.80	7.84	3.09
4	4500	4698.0	2415.3	441	16.0	1.76	125.2	2.06	9.47	9.46	3.61
5	8500	4854.6	2495.8	350	12.7	1.39	139.7	2.30	9.22	10.85	4.02
6	11000	4698.0	2415.3	313	11.3	1.25	128.9	2.12	8.79	10.50	3.71
7	29000	4854.6	2495.8	272	9.8	1.08	110.4	1.81	8.48	9.32	3.18
8	15000	4854.6	2495.8	433	15.7	1.73	113.4	1.86	8.57	9.47	3.27
9	9500	4698.0	2415.3	152	5.5	0.61	108.2	1.78	9.06	8.55	3.12
10	4000	4854.6	2495.8	193	7.0	0.77	95.8	1.57	9.45	7.26	2.76
11	500	4698.0	2415.3	317	11.5	1.26	65.2	1.07	9.46	4.93	1.88
12	0	4854.6	2495.8	285	10.3	1.14	57.4	0.94	9.74	4.22	1.65
Sum	87000	57159.5	29386.1		144.7	15.93	1194.5	19.63		92.66	34.40

Table H.11 Emergy calculation w/o service (a panel of flat solar collector)^a

Item	Area (m ²)	Volume (m ³)	Density (kg/m ³)	Weight (kg)	UEV (sej/kg)	Ref.	Emergy (sej)
Covering (float glass, thick. 3.2mm)	1.88	0.006016	2579	15.52	1.27E+13	[35]	1.97E+14
Absorber (coated copper plate, thick. 0.2mm)	1.88	0.000752	8960	6.74	1.09.E+14	[142]	7.34E+14
Tube (D8mm, 9ea at 100mm interval) ^b				2.03	1.09.E+14	[142]	2.21E+14
Heat reflection film (aluminum, thick. 0.1mm)	1.88	0.000188	2739	0.51	2.04E+13	[35]	1.05E+13
Insulation (glass wool, thick. 45mm)	1.88	0.0846	29	2.45	3.86E+12	[35]	9.47E+12
Frame and support (aluminum)				8.25	2.04E+13	[35]	1.68E+14
Total				35.50	3.78E+13		1.34E+15

a. Total weight of a panel: 35.5kg, Total dimension: 2.01m X 1.01m X 0.09m, Absorber area: 1.965m X 0.955m = 1.877 m²

b. Total tube length = 18m, Unit weight = 0.113 kg/m

c. UEVs are relative to 15.2E+24 baseline.

APPENDIX I Average household expense for maintenance and operation

Emergy inputs for building maintenance share a significant portion in emergy analysis. There is no exact estimation/simulation method of a household expenditure, but a report from Siniavskaja (2008) are useful to estimate emergy inputs to maintaining equipment and household items based on monetary expenses. Based on field survey and statistical data, this study reports that the average household spends \$1,971 for recurring expense of appliances and furnishings, and \$2,272 for repair. This result is similar to \$1,797 and \$2,510 (for apparel, house keeping supplies and services) reported from a coarse inspection (<http://www.creditloan.com/blog/how-the-average-us-consumer-spends-their-paycheck/>). Table I.1 to I.3 break down the

expense and present energy estimates using the UEV of a dollar (we use **1.47E+12 sej/\$** (Baral and Bakshi, 2010) to approximate more accurately the expenses to equipment repair and maintenance).

Table I.1 Annual household energy spending on building structure

Category	Type 1 ^a (\$/yr)	Type 2 ^b (\$/yr)	Type 1 (x10 ¹⁴ sej/yr)	Type 2 (x10 ¹⁴ sej/yr)
Repair				
Siding or roofing	5	37	0.07	0.54
Flooring	0	7	0.00	0.10
Windows or skylights	0	3	0.00	0.04
Doors	0	3	0.00	0.04
Painting	158	119	2.32	1.75
Other repairs	14	90	0.21	1.32
Total	177	259	2.6	3.79

a. First year after new construction (Siniavskaia, 2008), b. Non-moving home owners (Siniavskaia, 2008).

Table I.2 Annual household energy spending on maintenance of HVAC and water systems

Category	Type 1 ^a (\$/yr)	Type 2 ^b (\$/yr)	Type 1 (x10 ¹⁴ sej/yr)	Type 2 (x10 ¹⁴ sej/yr)
Repair				
Plumbing	3	34	0.04	0.50
HVAC	17	21	0.25	0.31
Replacement				
Plumbing fixtures	5	19	0.07	0.28
Water heater	0	8	0.00	0.12
Interior pipes	0	7	0.00	0.10
Total	25	89	0.36	1.31

a. First year after new construction (Siniavskaia, 2008), b. Non-moving home owners (Siniavskaia, 2008).

Table I.3 Annual household energy spending on electric equipment and appliances

Category	Type 1 ^a (\$/yr)	Type 2 ^b (\$/yr)	Type 1 (x 10 ¹⁴ sej/yr)	Type 2 (x 10 ¹⁴ sej/yr)
Electric range or oven	54	21	0.79	0.31
Gas range or oven	22	17	0.32	0.25
Microwave oven	18	11	0.26	0.16
Refridgerator	476	59	7.00	0.87
Home-freezer	14	7	0.21	0.10
Built-in dishwasher	37	21	0.54	0.31
Clothes washer/dryer	256	67	3.76	0.98

Small kitchen appliances	49	23	0.72	0.34
Electric floor cleaner	70	20	1.03	0.29
Power tools	54	28	0.79	0.41
Television	555	93	8.16	1.37
Video camera	28	26	0.41	0.38
Sound components/systems	81	46	1.19	0.68
Computer/accessories	285	199	4.19	2.93
Telephone/digital devices	54	25	0.79	0.37
Luminaries and decorative items	489	124	7.19	1.82
Other appliances	179	133	2.63	1.96
Electrical systems	3	6	0.04	0.09
Wiring (soft)	1	10	0.01	0.15
Total	2725	936	40.03	13.77

a. First year after new construction (Siniavskaia, 2008), **b.** Non-moving home owners (Siniavskaia, 2008). Average repair span is approximated based on the depreciation recovery period of business properties reported by the U.S. Internal Revenue Service (IRS) (http://www.irs.gov/publications/p946/ch04.html#en_US_2013_publink1000107525)

Table I.4 Annual household energy spending on furnishings

Category	Type 1 ^a (\$/yr)	Type 2 ^b (\$/yr)	Type 1 ($\times 10^{14}$ sej/yr)	Type 2 ($\times 10^{14}$ sej/yr)
Living room/sofas/chairs	1199	194	17.63	2.85
Shelves/cabinets	145	34	2.13	0.50
Other living/family furniture	250	49	3.68	0.72
All dining/kitchen furniture	559	54	8.22	0.79
Bedroom furniture	1193	228	17.54	3.35
Infants furniture and equipment	47	12	0.69	0.18
Outdoor furniture and equipment	187	40	2.75	0.59
Office furniture for home use	70	13	1.03	0.19
Glassware, dinnerware, cookware	62	39	0.91	0.57
Wall-to-wall carpeting	80	13	1.18	0.19
Non-permanent floor coverings	75	34	1.10	0.50
Curtains and window	896	52	13.17	0.76

coverings				
Other furnishings	26	17	0.38	0.25
Total	4789	779	70.41	11.44

a. First year after new construction (Siniavskaia, 2008), b. Non-moving home owners (Siniavskaia, 2008).

Table I.5 Annual household energy spending on yard management

Category	Type 1 ^a (\$/yr)	Type 2 ^b (\$/yr)	Type 1 (x10 ¹⁴ sej/yr)	Type 2 (x10 ¹⁴ sej/yr)
Repair				
Driveway or walk	1	10	0.01	0.15
Sprinkler system	0	1	0.00	0.01
Outside alteration	1377	179	20.24	2.63
Lawnmower/yard equipment	95	71	1.40	1.04
Total	1473	261	21.65	3.83

a. First year after new construction (Siniavskaia, 2008), b. Non-moving home owners (Siniavskaia, 2008).

Table I.6 Annual household energy spending on maintenance of disposal systems

Category	Type 1 ^a (\$/yr)	Type 2 ^b (\$/yr)	Type 1 (x10 ¹⁴ sej/yr)	Type 2 (x10 ¹⁴ sej/yr)
Garbage disposal	0	8	0.00	0.12
Septic tank	2	2	0.03	0.03
Total	2	10	0.03	0.15

a. First year after new construction (Siniavskaia, 2008), b. Non-moving home owners (Siniavskaia, 2008).

Table I.7 Food, clothing, and services

Category	Annual (\$)	Daily (\$) ^a	Emergy (x 10 ¹⁴ sej/yr) ^b	Emergy (x 10 ¹⁴ sej/day) ^b
Food – food at home	3,465	9.9	37.08	0.11
Apparel and Services	1,881	5.36	20.13	0.06
Sum	5,346	15.26	57.20	0.16

a. 14 vacation days of the BA house protocol are applied in estimation.

b. 1.20E+12 sej/\$ (Bastianoni et al., 2009)

On the otherhand, weight of household furniture and goods, based on a rule of thumb for movers) is 26.9 kg/m². Breakdown of the labor investment for building construction is as shown in Table I.8.

Table I.8 Time investment of human labor for construction (%)

Site work	Structure	System	Envelope	Interior	Total
6	25	12	31	26	100

APPENDIX J Average domestic water use and waste water

It is reported that the average American family uses 378.6L/day per person of water. Approximately, 265L/day (70%) is used indoors, and 113.6L/day (30%) outdoors (U.S. EPA). Waste water can be estimated according to the average ratio of the water drain source (Table J.1). From Table H.6, the average hotwater use is estimated as 76.3L/day per person (28.8% of indoor water use).

Table J.1 Breakdown of indoor waste water in the U.S. (from U.S. EPA)

Type	Drain source	Ratio (%)	Daily ($\times 10^3$ g) ^a	Annual ($\times 10^6$ g) ^{a, b}
Black water	Toilet	26.7	283.0	99.3
	Faucet/Kitchen sink	15.7	166.4	58.4
	Dishwasher	1.4	14.8	5.2
Gray water (reusable)	Bath and shower	18.6	197.2	69.2
	Clothes washing	21.7	230.0	80.7
Other	Leaks	13.7	145.2	51.0
	Others	2.2	23.3	8.2

a. Amount is estimated according to the usage ratio.

b. 14 vacation days of the BA house protocol are applied in estimation.

Emergy invested for waste water treatment

Typical residential water price in United States (2011-2012)(American Water Works Association): 0.5cents/gallons. Then, the estimate of service cost: municipal water cost ($1.32\text{E}-6\$/\text{g}$) – potable water value = ($1.32\text{E}-6\$/\text{g}$) \times ($1.5\text{E}+12\text{sej}/\text{\$}$) - ($9.1\text{E}+05\text{sej}/\text{g}$) = $2.0\text{E}+6 - 9.1\text{E}+5 = 1.1\text{E}+6 \text{ sej/g}$.

APPENDIX K Approximation of household solid waste disposal

Philadelphia municipal data

Philadelphia city council reports that each household produces the average amount of 1.25tons solid waste per year (3.42kg/day), and 48,000 tons are recycled by households in 731,000 tons of annual trash (6.6% recycling rate) (Dews and Wu, 2013). Trash pickup cost is approximately 0.14\$/kg (Dews and Wu, 2013).

	Raw data	Emergy
Solid waste generation per household	3.42 kg/day	1.26E+8 sej/day
Pickup cost	0.14 \$/kg	5.12E+11 sej/day
Recycling ratio	6.6%	

Maximum recyclable fraction of waste	66% ^a
--------------------------------------	------------------

a. <http://center.sustainability.duke.edu/resources/green-facts-consumers/how-much-do-we-waste-daily>

Note: Daily Esw = $3.42\text{E-}3 \text{ ton/day} \times (1\text{ha}/2.85\text{E+}4 \text{ ton waste}) \times (1.05\text{E+}15 \text{ sej/ha}) = 1.26\text{E+}08 \text{ sej/day}$

Pickup cost = $0.14 \times 3.42 \times 1.07\text{E+}12 \text{ sej/\$} \text{ (Bastianoni et al., 2009)} = 5.12\text{E+}11 \text{ sej/day}$

APPENDIX L Approximation of household emissions

(1) Average estimate of CO₂ equivalent amount

Jones and Kammen (2011) estimate carbon footprint of household emission by using EIO-LCA(Economic Input-Output Life Cycle Assessment) database and CEDA (Comprehensive Environmental Database Archive) for as of 2005. Inherent uncertainty in this estimation based on input-output analysis is around 10 to 15%.

Table L.2 Gas emissions, household average

Emission source	Units	Value
Housing construction	kgCO ₂ e/m ²	10
Electricity use (U.S. average)	kgCO ₂ /J	1.07E-07
Natural gas use (U.S. average)	kgCO ₂ /J	5.19E-09
Other fuels (U.S. average)	kgCO ₂ e/\\$	0.682
Waste water (sewage)	kgCO ₂ e/\\$	4121
Solid waste ^a	kgCO ₂ e/per/yr	313.66
Water supply ^b	kgCO ₂ /kg	0.26
Waste water treatment ^c	kgCO ₂ /kg	0.13
Food	kgCO ₂ e/kcal	2.92
Clothing	kgCO ₂ e/\\$	0.75
Furnishings, appliances, and other household goods	kgCO ₂ e/\\$	0.61
Maintenance and repair	kgCO ₂ e/\\$	0.13
Various services (education, personal business, recreation, etc.)	kgCO ₂ e/\\$	0.51

a. <http://www3.epa.gov/carbon-footprint-calculator/>

b. Carbon footprint of water (Griffiths-Sattenspiel and Wilson, 2009): Water supply including treatment and distribution: $2579\text{kWh}/\text{MG} \times 3\,600\,000 \text{ J/kWh} \times 1.07\text{E-}07\text{kgCO}_2/\text{J} / 3.79\text{E+}03\text{kg}/\text{MG} = 0.26 \text{ kgCO}_2/\text{kg}$

c. Wastewater treatment (assuming mid-size plant (20MGD) with advanced treatment): $1303\text{kWh}/\text{MG} \times 3\,600\,000 \text{ J/kWh} \times 1.07\text{E-}07\text{kgCO}_2/\text{J} / 3.79\text{E+}03\text{kg}/\text{MG} = 0.13 \text{ kgCO}_2/\text{kg}$

Note: Average food consumption pattern in the industrialized contries: $3440\text{kcal}/\text{per}/\text{day} \times (\text{food-at-home}\$ / \text{total food}\$; 3977/6602) = 2072.23\text{kcal}/\text{day-at-home}$ (http://www.who.int/nutrition/topics/3_foodconsumption).

(2) GHG emissions from electricity production in Pennsylvania

Table L.2 Green house gas emission for electricity production (Pennsylvania)

GHG	Efficiency a	CO ₂ ^b	CO ^c	CH ₄ ^b	NO ^d	N ₂ O ^b	SO ₂ ^d
g/MJ	0.55	159.26	1858.85	0.0013	0.33	0.0026	1.26
Pollutant	Particulate Matter (PM) ^{ce}	PM10 ^{ce}	PM2.5 ^{ce}	NH ₃ ^c	Volatile Organic Compounds (NMVOC) ^d	Hg ^c	Pb ^f
g/MJ	0.022	0.022	0.00015	0.00015	0.0015	0.000007	0

a. Ratio of electricity output to heat input. **b.** Data based on 1998-2000 average data in DOE (2002). **c.** Data based on tier emissions report for criteria air pollutants in EPA (2003b). **d.** Data based on 1999 data from *eGRID* version 2.01 (EPA 2003a). **e.** PM is the sum of all particulate matter including PM10 and PM2.5. PM10 and PM2.5 stand for particles smaller than 10 and 2.5 microns, respectively. **f.** No data.

APPENDIX M Energy evaluation factors of downstream effects

Table M.1 Lists of emissions and environmental impacts (Liu et al., 2011)

Pollution type	Pollutant	DY (/kg)	DY × Em _p ^a (sej/kg•yr)	DF × m ² × yr
Airbone	CO ₂	2.10 × 10 ⁻⁷	3.63 × 10 ¹⁰	
	NO _x	8.87 × 10 ⁻⁵	1.53 × 10 ¹³	5.71 ^b
	SO ₂	5.46 × 10 ⁻⁵	9.45 × 10 ¹²	1.04 ^b
	N ₂ O	6.90 × 10 ⁻⁵	1.19 × 10 ¹³	
	CH ₄ ^c	1.28 × 10 ⁻⁸	2.21 × 10 ⁹	
	CH ₄ ^d	4.40 × 10 ⁻⁶	7.61 × 10 ¹¹	
	Dust	3.75 × 10 ⁻⁴	6.49 × 10 ¹³	
Waterbone	Mercury			197 ^e
	Cadmium	7.12 × 10 ⁻²	1.23 × 10 ¹⁶	480 ^e
	Hexavalent chromium	3.43 × 10 ⁻¹	5.93 × 10 ¹⁶	
	Lead			7.39
	Arsenic	6.57 × 10 ⁻²	1.14 × 10 ¹⁶	11.4
	Volatile phenol	1.05 × 10 ⁻⁵	1.82 × 10 ¹²	
	Cyanide	4.16 × 10 ⁻⁵	7.20 × 10 ¹²	
	Oil	4.16 × 10 ⁻⁵	7.20 × 10 ¹²	

a. Em_p = 1.73 × 10¹⁷sej/yr (Hossaini and Hewage, 2013) **b.** Damage to ecosystems by acidification **c.** Effect for respiratory disorders **d.** Climate change effect **e.** Damage to ecosystems by toxic emissions

APPENDIX N Embodied energy, construction waste, transport, and building life spans

Table N.1 Primary energy for manufacturing (M) and the production ratio of construction waste (w)

Materials	M (kWh/ton) ^a	w ^b
Concrete, reinforced	560	0.2
Concrete, plain	210	0.1
Gypsum wallboard	2400	0.1
Tiles and clinkers	2000	0.1
Timber: rough saw (0.5 ton/m ³)	1440	0.1
Timber: planed (0.5 ton/m ³)	2240	0.1
Timber: shingles and shavings (0.6 ton/m ³)	3150	0.07
Glass	7230	0
Mineral Wool	5330	0.1
Polyvinyl chloride (PVC)	24650	0.05
Polythene	16400	0.05
Polystyrene	29650	0.1
Coatings: paints and lacquers	7000	0.05
Steel	8890	0.05
Copper	19500	0.05
Ventilating channels, sheet metal	9000	0.1
Electric wires, cooper	19780	0.05
White goods, 1110 kWh/item	-	0

a. Andersen et al., 1993, b. Larsson, 1983

Table N.2 Energy estimate of building works other than operational phases

Energy for construction, transport, and demolition	1% of total life cycle energy (Sartori and Hestnes, 2007)
Energy use of demolition material transport	30% of raw material transport (Thormark, 2002)
Site excavation	1% of the annual household energy use (Marceau et al., 2008)
Maintenance	12% of the total embodied energy (Thormark, 2002)
Demolition	Negligible (Bekker, 1982; Fay, 2000; Sartori and Hestnes, 2007)

Table N.3 Life spans of building components used in this study

Reference	<i>a</i>	<i>b</i>	<i>c</i>	<i>d</i>	<i>e</i>	<i>f</i>	<i>g</i>	<i>Mean</i>
<i>Building Lifetime</i>	50	100				100		
<i>Structure & Envelope</i>								
Foundation	50		50		110		100	78
Structural frames	50		50	50	74		100	65
Envelope (siding)	50	33.3			40		75	50
Interior walls (gypsum) and ceilings	50		50	30	29		100	52
Insulation	50		50				100	67
Caulking		10					8	9
Flooring (hard)	50		50	28			100	57
Carpeting, pad	17	10					9	12
Paint (interior) and wall papering	10	10	15	5		10	15	11
Paint (exterior)		5	15			10	7	12
Wooden panels	30						45	38
Windows and skylights	30	33.3	24	30	43	50	22	33
Doors	30	33.3	40				22	31
Roofing (wood, tiles, felt and asphalt shingles)	30	30	32	27		38	30	31
Drain pipes, ridge vents, gable	30	33.3	44		45		38	38
<i>HVAC</i>								
Water pipe	50			30	47	50	60	47
Ductwork			10	30			10	17
Fans			10	20			10	13
Water heater	16	20	15	10			11	14
Air conditioner		20	13	13			12	15
Furnace (Gas, Oil)		20	18	18			18	19
Boiler			17	27	20		17	20
Heat pump			16	15			16	16
Air Terminals (Fan-coil units, VAV boxes, diffusers, etc.)			13	22			13	16
Thermostats			35		17		35	29
<i>Electric & Fixtures</i>								
Electric wires	50		50				100	67
Kitchen furnitures (cabinetry, wardrobes, cupboards)	30	25	50				35	35
Bathroom fixtures and furnitures (shower, toilet, tub)		25		30			35	30
Garbage disposal		20	12					16
Major appliances (fridge, range, stove, washer, dryer, etc.)		15	13			19	13	15
Lighting fixtures				20	32		20	24
Others (Average except wiring)								24

a. normal maintenance based on experience (no extensions or considerable changes) **b.** house component replacement **c.** National Association of Home Builders, Study of Life expectancy of Home components, Technical Report, Bank of America Home Equity, 2007. **d.** <http://www.menlofire.org/pdf/fca/06.%20Appendices/Appendix%204%20-%20Nominal%20Life%20Expectancy~.pdf> (accessed Mar. 11, 2014) **e.** <http://www.costmodelling.com/downloads/BuildingComponentLifeExpectancy.pdf> (accessed Mar. 10, 2014)

f. Fay, R., Treloar, G., and Iyer-Raniga, U. (2000). Life-cycle energy analysis of buildings: a case study. Building Research & Information 28, 31-41. g. AVERAGE LIFE SPAN OF HOMES, APPLIANCES, AND MECHANICALS

APPENDIX O US household average number of lamps, daily house-of-use (HOU), and lamp types (US DOE, 2012, Residential Lighting Study)

Table O.1 US household average number of lamps, daily house-of-use (HOU), and lamp types

Room	All lamp types		Compact fluorescent		Incandescent		Other	
	Number of Lamps	HOU per Lamp	Number of Lamps	HOU per Lamp	Number of Lamps	HOU per Lamp	Number of Lamps	HOU per Lamp
Overall	67.4	1.6	14.3	1.9	41.9	1.2	11.2	1.5
Bedroom	15.9	1.2	3.9	1.4	10.5	1.0	1.5	1.0
Bathrooms	10.4	1.2	2.2	1.4	7.4	1.1	0.8	1.2
Dining	2.8	1.6	0.4	1.8	2.3	1.6	0.1	1.4
Garages	3.2	1.1	0.5	1.7	1.3	0.5	1.4	1.2
Hallways	6.0	0.8	1.2	1.4	4.4	0.7	0.4	0.4
Kitchens	6.1	2.3	1.3	2.5	2.9	1.7	2.0	2.0
Living	5.5	1.7	1.4	2.1	3.6	1.6	0.5	0.5
Other	7.2	1.3	1.5	1.6	3.6	1.0	2.2	2.2
Offices	1.2	1.5	0.3	1.5	0.7	1.1	0.2	0.2
Exterior	9.0	2.9	1.7	3.5	5.3	2.0	2.1	2.1

Note: Average lamp power is 47.7 W.

APPENDIX P Emery cost for construction labor

Emery inputs of direct construction labor (machine cost was not considered in this study of small residential buildings) for case study buildings can be estimated as follows.

(1) South Korea: Average 31.5% of total construction cost/~ \$428.98/m² as of 2010 (Korean Public Procurement Service, 2010 Construction cost estimate for public buildings, Government report, 2010).

(2) US: Average total construction cost for a single-family house (<http://www.fixr.com/costs/build-single-family-house>) is \$117/ft² (\$1,259.42/m²). Labor cost covers about 49.1% of total construction, thus, it is about \$57.45/ft² (\$618.41/m²).

Table P.1 Calculation of construction cost

	South Korea	US
Percentage of total construction cost (%)	31.5	49.1
Labor cost intensity (\$/per floor area, m ²)	428.98 ^a	618.41
Emery intensity (sej/m ²) ^b	4.59E+14	6.62E+14
Indirect service intensity (\$/per floor area, m ²)	28.77	

a. 1\$ = 1,050 Korean Won. b. 1.07sej/\$ applied.

APPENDIX Q Air infiltration rates and simulation inputs for Building B

For comparative analysis, occupancy schedules are assumed to be the same as the baseline (Building A). Air-infiltration in the energy simulation of Building B is estimated as 0.277 L/s/m^2 (@50Pa) = $1.00 \text{ m}^3/\text{hr}/\text{m}^2 \approx 0.34 \text{ ACH50}$, then finally, we get $0.34/20 \approx 0.02 \text{ ACH}$. Passive house standards developed by the Passive House Institute (PHI), ACH50 must be less than 0.6, then $0.6/20 = 0.03 \text{ ACH}$ in a natural condition. Building B meets this criterion (As for energy use, it is advised that Passive House's annual heating energy consumption strictly not greater than or equal to 15 kWh/m^2 (per net conditioned area), and total primary energy demand must be less than or equal to 120 kWh/m^2).

Table Q.1 Air infiltration rates and green building standards

ACH50	ACH	Description
10~20	0.5~1	Old houses or barns
7~10	0.35~0.5	Average new home with little attention to sealing
7	0.35	2009 IECC energy code requirement
3~5	0.15~0.25	ENERGY STAR reference home (ACH 0.25)
≤ 3	0.15	Airtight construction
≤ 0.6	0.03	Passive house requirement

Airflow rates due to window opening are varying depending on behavioral scenarios and outside weather conditions. For an estimate, 7 ACH was used as an input value by referencing experimental data (Guo et al., 2008; Becker, Haquin, and Kovler, 2014).

Table Q.2 Other simulation inputs for Building B

Average lighting density	$9.17 \text{ W}/\text{m}^2$
Total equipment power	2186.8 W
Heat exchanger (flat type)	0.85 (sensible effectiveness), 0.6 (latent effectiveness), 0.7 (total)

APPENDIX R Depreciation of materials and equipment

It is natural to assume that ecological values of building materials, electric equipment, and services are peak at first and rapidly depreciated with the course of time, because they are basically market-based economic goods. Applying the

declining balance method and the frequency of replacement (Table N.3), dynamic trends of the building inputs can be calculated as follows (Fig. R.1 and R.2).

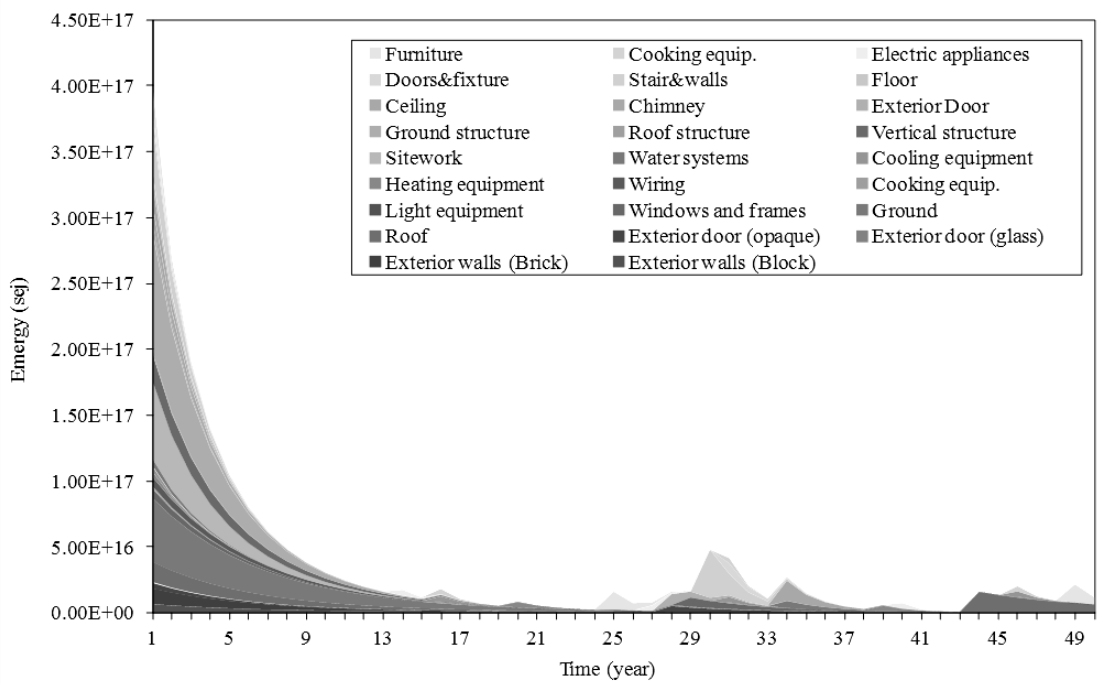

Fig. R.1 Building A (Baseline)

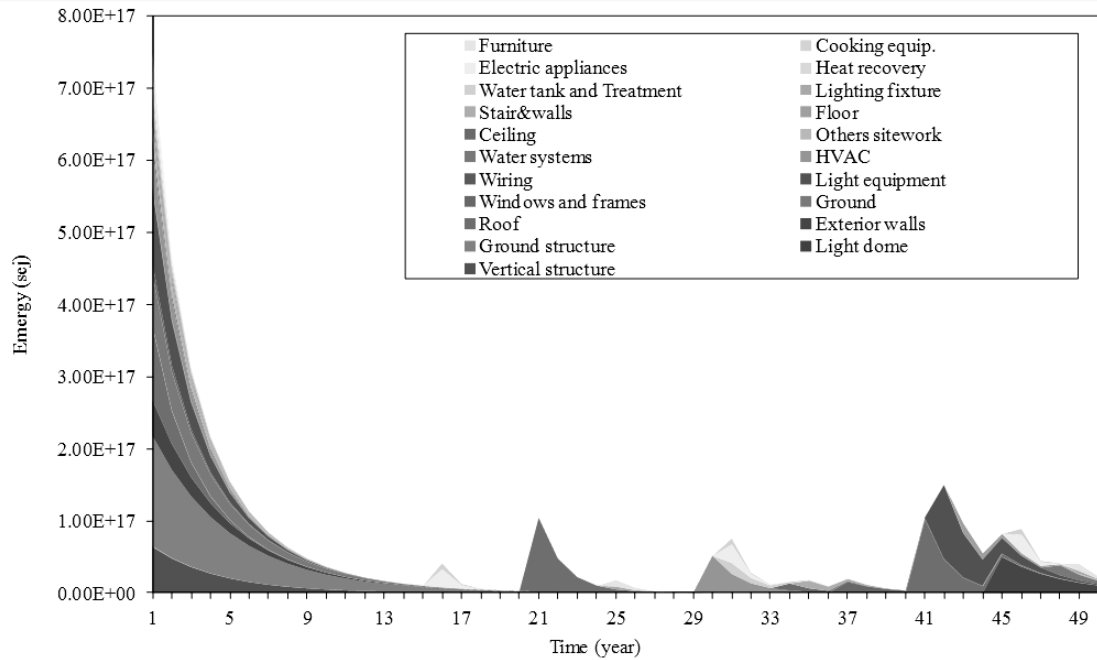

Fig. R.2 Building B (NZEB)

APPENDIX S Energy flow calculation results

Table S.1 Whole building system, Building B (yearly, 50years)

Year	1	2	3	4	5	6	7	8	9	10	11	12	13	14	15	16	17	18	19	20	21	22	23	24	25	
1	5.98E-12	5.98E-12	5.98E-12	5.98E-12	5.98E-12	5.98E-12	5.98E-12	5.98E-12	5.98E-12	5.98E-12	5.98E-12	5.98E-12	5.98E-12	5.98E-12	5.98E-12	5.98E-12	5.98E-12	5.98E-12	5.98E-12	5.98E-12	5.98E-12	5.98E-12	5.98E-12	5.98E-12	5.98E-12	5.98E-12

Table S.2 Whole building system, Building B (monthly, 33years after completion)

	1	2	3	4	5	6	7	8	9	10	11	12	13	14	15	16	17	18	19	20	21	22	23	24	
<i>f₁</i>	7.69E+12	8.18E+12	1.02E+13	1.18E+13	8.66E+12	1.38E+13	1.46E+13	8.75E+12	1.49E+13	1.31E+13	1.26E+13	1.58E+12	1.52E+13	1.28E+13	1.49E+12	1.46E+13	1.66E+13	1.69E+13	1.67E+13	1.15E+13	1.67E+13	1.91E+13	1.42E+13	1.42E+13	1.59E+13
<i>f₂</i>	1.63E+12	1.63E+12	2.81E+12	2.57E+12	2.44E+12	2.11E+12	2.21E+12	2.28E+12	2.28E+12	3.35E+12	2.67E+12	2.67E+12	2.67E+12	2.67E+12	2.67E+12	2.67E+12	2.67E+12	2.67E+12	2.67E+12	2.67E+12	2.67E+12	2.67E+12	2.67E+12	2.67E+12	2.67E+12
<i>f₃</i>	1.53E+10	1.31E+10	1.88E+10	1.95E+10	1.95E+10	1.95E+10	1.95E+10	1.95E+10	1.95E+10	1.95E+10	1.95E+10	1.95E+10	1.95E+10	1.95E+10	1.95E+10	1.95E+10	1.95E+10	1.95E+10	1.95E+10	1.95E+10	1.95E+10	1.95E+10	1.95E+10	1.95E+10	1.95E+10
<i>f₄</i>	0	0	0	0	0	0	0	0	0	0	0	0	0	0	0	0	0	0	0	0	0	0	0	0	0
<i>f₅</i>	0	0	0	0	0	0	0	0	0	0	0	0	0	0	0	0	0	0	0	0	0	0	0	0	0
<i>f₆</i>	1.22E+09	9.82E+08	1.24E+09	1.44E+09	1.25E+09	1.09E+09	1.35E+09	1.47E+09	8.96E+08	1.32E+09	1.12E+09	1.43E+09	1.05E+09	1.38E+09	1.19E+09	1.38E+09	1.38E+09	1.38E+09	1.38E+09	1.38E+09	1.38E+09	1.38E+09	1.38E+09	1.38E+09	1.38E+09
<i>f₇</i>	3.58E+11	3.58E+11	3.58E+11	3.58E+11	3.58E+11	3.58E+11	3.58E+11	3.58E+11	3.58E+11	3.58E+11	3.58E+11	3.58E+11	3.58E+11	3.58E+11	3.58E+11	3.58E+11	3.58E+11	3.58E+11	3.58E+11	3.58E+11	3.58E+11	3.58E+11	3.58E+11	3.58E+11	
<i>f₈</i>	6.93E+09	6.93E+09	6.93E+09	6.93E+09	6.93E+09	6.93E+09	6.93E+09	6.93E+09	6.93E+09	6.93E+09	6.93E+09	6.93E+09	6.93E+09	6.93E+09	6.93E+09	6.93E+09	6.93E+09	6.93E+09	6.93E+09	6.93E+09	6.93E+09	6.93E+09	6.93E+09	6.93E+09	
<i>f₉</i>	3.00E+12	3.00E+12	3.00E+12	3.00E+12	3.00E+12	3.00E+12	3.00E+12	3.00E+12	3.00E+12	3.00E+12	3.00E+12	3.00E+12	3.00E+12	3.00E+12	3.00E+12	3.00E+12	3.00E+12	3.00E+12	3.00E+12	3.00E+12	3.00E+12	3.00E+12	3.00E+12	3.00E+12	
<i>f₁₀</i>	2.92E+08	2.92E+08	2.92E+08	2.92E+08	2.92E+08	2.92E+08	2.92E+08	2.92E+08	2.92E+08	2.92E+08	2.92E+08	2.92E+08	2.92E+08	2.92E+08	2.92E+08	2.92E+08	2.92E+08	2.92E+08	2.92E+08	2.92E+08	2.92E+08	2.92E+08	2.92E+08	2.92E+08	
<i>f₁₁</i>	2.00E+12	2.00E+12	2.00E+12	2.00E+12	2.00E+12	2.00E+12	2.00E+12	2.00E+12	2.00E+12	2.00E+12	2.00E+12	2.00E+12	2.00E+12	2.00E+12	2.00E+12	2.00E+12	2.00E+12	2.00E+12	2.00E+12	2.00E+12	2.00E+12	2.00E+12	2.00E+12	2.00E+12	
<i>f₁₂</i>	3.26E+12	3.26E+12	3.26E+12	3.26E+12	3.26E+12	3.26E+12	3.26E+12	3.26E+12	3.26E+12	3.26E+12	3.26E+12	3.26E+12	3.26E+12	3.26E+12	3.26E+12	3.26E+12	3.26E+12	3.26E+12	3.26E+12	3.26E+12	3.26E+12	3.26E+12	3.26E+12	3.26E+12	
<i>f₁₃</i>	1.00E+14	1.00E+14	1.00E+14	1.00E+14	1.00E+14	1.00E+14	1.00E+14	1.00E+14	1.00E+14	1.00E+14	1.00E+14	1.00E+14	1.00E+14	1.00E+14	1.00E+14	1.00E+14	1.00E+14	1.00E+14	1.00E+14	1.00E+14	1.00E+14	1.00E+14	1.00E+14	1.00E+14	
<i>f₁₄</i>	5.59E+10	5.59E+10	5.59E+10	5.59E+10	5.59E+10	5.59E+10	5.59E+10	5.59E+10	5.59E+10	5.59E+10	5.59E+10	5.59E+10	5.59E+10	5.59E+10	5.59E+10	5.59E+10	5.59E+10	5.59E+10	5.59E+10	5.59E+10	5.59E+10	5.59E+10	5.59E+10	5.59E+10	
<i>f₁₅</i>	1.88E+14	1.88E+14	1.88E+14	1.88E+14	1.88E+14	1.88E+14	1.88E+14	1.88E+14	1.88E+14	1.88E+14	1.88E+14	1.88E+14	1.88E+14	1.88E+14	1.88E+14	1.88E+14	1.88E+14	1.88E+14	1.88E+14	1.88E+14	1.88E+14	1.88E+14	1.88E+14	1.88E+14	
<i>f₁₆</i>	1.00E+14	1.00E+14	1.00E+14	1.00E+14	1.00E+14	1.00E+14	1.00E+14	1.00E+14	1.00E+14	1.00E+14	1.00E+14	1.00E+14	1.00E+14	1.00E+14	1.00E+14	1.00E+14	1.00E+14	1.00E+14	1.00E+14	1.00E+14	1.00E+14	1.00E+14	1.00E+14	1.00E+14	
<i>f₁₇</i>	4.38E+08	4.38E+08	4.38E+08	4.38E+08	4.38E+08	4.38E+08	4.38E+08	4.38E+08	4.38E+08	4.38E+08	4.38E+08	4.38E+08	4.38E+08	4.38E+08	4.38E+08	4.38E+08	4.38E+08	4.38E+08	4.38E+08	4.38E+08	4.38E+08	4.38E+08	4.38E+08	4.38E+08	
<i>f₁₈</i>	5.34E+10	5.34E+10	5.34E+10	5.34E+10	5.34E+10	5.34E+10	5.34E+10	5.34E+10	5.34E+10	5.34E+10	5.34E+10	5.34E+10	5.34E+10	5.34E+10	5.34E+10	5.34E+10	5.34E+10	5.34E+10	5.34E+10	5.34E+10	5.34E+10	5.34E+10	5.34E+10	5.34E+10	
<i>f₁₉</i>	2.03E+09	2.03E+09	2.03E+09	2.03E+09	2.03E+09	2.03E+09	2.03E+09	2.03E+09	2.03E+09	2.03E+09	2.03E+09	2.03E+09	2.03E+09	2.03E+09	2.03E+09	2.03E+09	2.03E+09	2.03E+09	2.03E+09	2.03E+09	2.03E+09	2.03E+09	2.03E+09	2.03E+09	
<i>f₂₀</i>	1.47E+11	1.47E+11	1.47E+11	1.47E+11	1.47E+11	1.47E+11	1.47E+11	1.47E+11	1.47E+11	1.47E+11	1.47E+11	1.47E+11	1.47E+11	1.47E+11	1.47E+11	1.47E+11	1.47E+11	1.47E+11	1.47E+11	1.47E+11	1.47E+11	1.47E+11	1.47E+11	1.47E+11	
<i>f₂₁</i>	4.25E+13	4.25E+13	4.25E+13	4.25E+13	4.25E+13	4.25E+13	4.25E+13	4.25E+13	4.25E+13	4.25E+13	4.25E+13	4.25E+13	4.25E+13	4.25E+13	4.25E+13	4.25E+13	4.25E+13	4.25E+13	4.25E+13	4.25E+13	4.25E+13	4.25E+13	4.25E+13	4.25E+13	
<i>f₂₂</i>	3.68E+10	3.68E+10	3.68E+10	3.68E+10	3.68E+10	3.68E+10	3.68E+10	3.68E+10	3.68E+10	3.68E+10	3.68E+10	3.68E+10	3.68E+10	3.68E+10	3.68E+10	3.68E+10	3.68E+10	3.68E+10	3.68E+10	3.68E+10	3.68E+10	3.68E+10	3.68E+10	3.68E+10	
<i>f₂₃</i>	0	0	0	0	0	0	0	0	0	0	0	0	0	0	0	0	0	0	0	0	0	0	0	0	
<i>f₂₄</i>	0	0	0	0	0	0	0	0	0	0	0	0	0	0	0	0	0	0	0	0	0	0	0	0	

Table S.3 Whole building system, Building A (yearly, 50years)

Year	1	2	3	4	5	6	7	8	9	10	11	12	13	14	15	16	17	18	19	20	21	22	23	24	25
1	6.62E-13	6.62E-13	6.62E-13	6.62E-13	6.62E-13	6.62E-13	6.62E-13	6.62E-13	6.62E-13	6.62E-13	6.62E-13	6.62E-13	6.62E-13	6.62E-13	6.62E-13	6.62E-13	6.62E-13	6.62E-13	6.62E-13	6.62E-13	6.62E-13	6.62E-13	6.62E-13	6.62E-13	6.62E-13
...
50	6.62E-13	6.62E-13	6.62E-13	6.62E-13	6.62E-13	6.62E-13	6.62E-13	6.62E-13	6.62E-13	6.62E-13	6.62E-13	6.62E-13	6.62E-13	6.62E-13	6.62E-13	6.62E-13	6.62E-13	6.62E-13	6.62E-13	6.62E-13	6.62E-13	6.62E-13	6.62E-13	6.62E-13	6.62E-13

Table S.4 Whole building system, Building A (monthly, 33years after completion)

Year	Month	Energy Demand (kWh)		Energy Cost (€)		CO ₂ Emissions (t)		Water Demand (m ³)		Water Cost (€)	
		Electricity	Gas	Electricity	Gas	Electricity	Gas	Hot Water	Cold Water	Hot Water	Cold Water
2010	1	720E+10	832E+10	1.0E+11	1.2E+11	5.9E+11	2.3E+11	1.0E+10	1.3E+10	2.1E+09	2.5E+09
	2	720E+10	832E+10	1.0E+11	1.2E+11	5.9E+11	2.3E+11	1.0E+10	1.3E+10	2.1E+09	2.5E+09
	3	720E+10	832E+10	1.0E+11	1.2E+11	5.9E+11	2.3E+11	1.0E+10	1.3E+10	2.1E+09	2.5E+09
	4	720E+10	832E+10	1.0E+11	1.2E+11	5.9E+11	2.3E+11	1.0E+10	1.3E+10	2.1E+09	2.5E+09
	5	720E+10	832E+10	1.0E+11	1.2E+11	5.9E+11	2.3E+11	1.0E+10	1.3E+10	2.1E+09	2.5E+09
	6	720E+10	832E+10	1.0E+11	1.2E+11	5.9E+11	2.3E+11	1.0E+10	1.3E+10	2.1E+09	2.5E+09
	7	720E+10	832E+10	1.0E+11	1.2E+11	5.9E+11	2.3E+11	1.0E+10	1.3E+10	2.1E+09	2.5E+09
	8	720E+10	832E+10	1.0E+11	1.2E+11	5.9E+11	2.3E+11	1.0E+10	1.3E+10	2.1E+09	2.5E+09
	9	720E+10	832E+10	1.0E+11	1.2E+11	5.9E+11	2.3E+11	1.0E+10	1.3E+10	2.1E+09	2.5E+09
	10	720E+10	832E+10	1.0E+11	1.2E+11	5.9E+11	2.3E+11	1.0E+10	1.3E+10	2.1E+09	2.5E+09
	11	720E+10	832E+10	1.0E+11	1.2E+11	5.9E+11	2.3E+11	1.0E+10	1.3E+10	2.1E+09	2.5E+09
	12	720E+10	832E+10	1.0E+11	1.2E+11	5.9E+11	2.3E+11	1.0E+10	1.3E+10	2.1E+09	2.5E+09
2011	1	720E+10	832E+10	1.0E+11	1.2E+11	5.9E+11	2.3E+11	1.0E+10	1.3E+10	2.1E+09	2.5E+09
	2	720E+10	832E+10	1.0E+11	1.2E+11	5.9E+11	2.3E+11	1.0E+10	1.3E+10	2.1E+09	2.5E+09
	3	720E+10	832E+10	1.0E+11	1.2E+11	5.9E+11	2.3E+11	1.0E+10	1.3E+10	2.1E+09	2.5E+09
	4	720E+10	832E+10	1.0E+11	1.2E+11	5.9E+11	2.3E+11	1.0E+10	1.3E+10	2.1E+09	2.5E+09
	5	720E+10	832E+10	1.0E+11	1.2E+11	5.9E+11	2.3E+11	1.0E+10	1.3E+10	2.1E+09	2.5E+09
	6	720E+10	832E+10	1.0E+11	1.2E+11	5.9E+11	2.3E+11	1.0E+10	1.3E+10	2.1E+09	2.5E+09
	7	720E+10	832E+10	1.0E+11	1.2E+11	5.9E+11	2.3E+11	1.0E+10	1.3E+10	2.1E+09	2.5E+09
	8	720E+10	832E+10	1.0E+11	1.2E+11	5.9E+11	2.3E+11	1.0E+10	1.3E+10	2.1E+09	2.5E+09
	9	720E+10	832E+10	1.0E+11	1.2E+11	5.9E+11	2.3E+11	1.0E+10	1.3E+10	2.1E+09	2.5E+09
	10	720E+10	832E+10	1.0E+11	1.2E+11	5.9E+11	2.3E+11	1.0E+10	1.3E+10	2.1E+09	2.5E+09
	11	720E+10	832E+10	1.0E+11	1.2E+11	5.9E+11	2.3E+11	1.0E+10	1.3E+10	2.1E+09	2.5E+09
	12	720E+10	832E+10	1.0E+11	1.2E+11	5.9E+11	2.3E+11	1.0E+10	1.3E+10	2.1E+09	2.5E+09
2012	1	720E+10	832E+10	1.0E+11	1.2E+11	5.9E+11	2.3E+11	1.0E+10	1.3E+10	2.1E+09	2.5E+09
	2	720E+10	832E+10	1.0E+11	1.2E+11	5.9E+11	2.3E+11	1.0E+10	1.3E+10	2.1E+09	2.5E+09
	3	720E+10	832E+10	1.0E+11	1.2E+11	5.9E+11	2.3E+11	1.0E+10	1.3E+10	2.1E+09	2.5E+09
	4	720E+10	832E+10	1.0E+11	1.2E+11	5.9E+11	2.3E+11	1.0E+10	1.3E+10	2.1E+09	2.5E+09
	5	720E+10	832E+10	1.0E+11	1.2E+11	5.9E+11	2.3E+11	1.0E+10	1.3E+10	2.1E+09	2.5E+09
	6	720E+10	832E+10	1.0E+11	1.2E+11	5.9E+11	2.3E+11	1.0E+10	1.3E+10	2.1E+09	2.5E+09
	7	720E+10	832E+10	1.0E+11	1.2E+11	5.9E+11	2.3E+11	1.0E+10	1.3E+10	2.1E+09	2.5E+09
	8	720E+10	832E+10	1.0E+11	1.2E+11	5.9E+11	2.3E+11	1.0E+10	1.3E+10	2.1E+09	2.5E+09
	9	720E+10	832E+10	1.0E+11	1.2E+11	5.9E+11	2.3E+11	1.0E+10	1.3E+10	2.1E+09	2.5E+09
	10	720E+10	832E+10	1.0E+11	1.2E+11	5.9E+11	2.3E+11	1.0E+10	1.3E+10	2.1E+09	2.5E+09
	11	720E+10	832E+10	1.0E+11	1.2E+11	5.9E+11	2.3E+11	1.0E+10	1.3E+10	2.1E+09	2.5E+09
	12	720E+10	832E+10	1.0E+11	1.2E+11	5.9E+11	2.3E+11	1.0E+10	1.3E+10	2.1E+09	2.5E+09

Table S.5 Envelope, Building B (yearly, 50 years)

Year	1	2	3	4	5	6	7	8	9	10	11	12	13	14	15	16	17	18	19	20	21	22	23	24	25
Jan	612E-12	612E-12	612E-12	612E-12	612E-12	612E-12	612E-12	612E-12	612E-12	612E-12	612E-12	612E-12	612E-12	612E-12	612E-12	612E-12	612E-12	612E-12	612E-12	612E-12	612E-12	612E-12	612E-12	612E-12	612E-12
Feb	173E-12	173E-12	173E-12	173E-12	173E-12	173E-12	173E-12	173E-12	173E-12	173E-12	173E-12	173E-12	173E-12	173E-12	173E-12	173E-12	173E-12	173E-12	173E-12	173E-12	173E-12	173E-12	173E-12	173E-12	173E-12
Mar	0	15E-11	0	15E-11	0	15E-11	0	15E-11	0	15E-11	0	15E-11	0	15E-11	0	15E-11	0	15E-11	0	15E-11	0	15E-11	0	15E-11	0
Apr	63E-11	63E-11	63E-11	63E-11	63E-11	63E-11	63E-11	63E-11	63E-11	63E-11	63E-11	63E-11	63E-11	63E-11	63E-11	63E-11	63E-11	63E-11	63E-11	63E-11	63E-11	63E-11	63E-11	63E-11	63E-11
May	701E-10	701E-10	701E-10	701E-10	701E-10	701E-10	701E-10	701E-10	701E-10	701E-10	701E-10	701E-10	701E-10	701E-10	701E-10	701E-10	701E-10	701E-10	701E-10	701E-10	701E-10	701E-10	701E-10	701E-10	701E-10
Jun	431E-10	431E-10	431E-10	431E-10	431E-10	431E-10	431E-10	431E-10	431E-10	431E-10	431E-10	431E-10	431E-10	431E-10	431E-10	431E-10	431E-10	431E-10	431E-10	431E-10	431E-10	431E-10	431E-10	431E-10	431E-10
Jul	508E-09	508E-09	508E-09	508E-09	508E-09	508E-09	508E-09	508E-09	508E-09	508E-09	508E-09	508E-09	508E-09	508E-09	508E-09	508E-09	508E-09	508E-09	508E-09	508E-09	508E-09	508E-09	508E-09	508E-09	508E-09
Aug	1.58E-09	1.58E-09	1.58E-09	1.58E-09	1.58E-09	1.58E-09	1.58E-09	1.58E-09	1.58E-09	1.58E-09	1.58E-09	1.58E-09	1.58E-09	1.58E-09	1.58E-09	1.58E-09	1.58E-09	1.58E-09	1.58E-09	1.58E-09	1.58E-09	1.58E-09	1.58E-09	1.58E-09	1.58E-09
Sep	4.22E-09	4.22E-09	4.22E-09	4.22E-09	4.22E-09	4.22E-09	4.22E-09	4.22E-09	4.22E-09	4.22E-09	4.22E-09	4.22E-09	4.22E-09	4.22E-09	4.22E-09	4.22E-09	4.22E-09	4.22E-09	4.22E-09	4.22E-09	4.22E-09	4.22E-09	4.22E-09	4.22E-09	4.22E-09
Oct	6.27E-09	6.27E-09	6.27E-09	6.27E-09	6.27E-09	6.27E-09	6.27E-09	6.27E-09	6.27E-09	6.27E-09	6.27E-09	6.27E-09	6.27E-09	6.27E-09	6.27E-09	6.27E-09	6.27E-09	6.27E-09	6.27E-09	6.27E-09	6.27E-09	6.27E-09	6.27E-09	6.27E-09	6.27E-09
Nov	7.73E-09	7.73E-09	7.73E-09	7.73E-09	7.73E-09	7.73E-09	7.73E-09	7.73E-09	7.73E-09	7.73E-09	7.73E-09	7.73E-09	7.73E-09	7.73E-09	7.73E-09	7.73E-09	7.73E-09	7.73E-09	7.73E-09	7.73E-09	7.73E-09	7.73E-09	7.73E-09	7.73E-09	7.73E-09
Dec	6.21E-09	6.21E-09	6.21E-09	6.21E-09	6.21E-09	6.21E-09	6.21E-09	6.21E-09	6.21E-09	6.21E-09	6.21E-09	6.21E-09	6.21E-09	6.21E-09	6.21E-09	6.21E-09	6.21E-09	6.21E-09	6.21E-09	6.21E-09	6.21E-09	6.21E-09	6.21E-09	6.21E-09	6.21E-09
Jan	1.88E-17	1.88E-17	1.88E-17	1.88E-17	1.88E-17	1.88E-17	1.88E-17	1.88E-17	1.88E-17	1.88E-17	1.88E-17	1.88E-17	1.88E-17	1.88E-17	1.88E-17	1.88E-17	1.88E-17	1.88E-17	1.88E-17	1.88E-17	1.88E-17	1.88E-17	1.88E-17	1.88E-17	1.88E-17
Feb	5.30E-16	2.92E-16	610E-16	1.92E-16	630E-16	3.40E-16	2.12E-16	3.80E-16	8.38E-16	3.52E-16	3.51E-16	2.32E-16	1.80E-16	1.50E-16	1.08E-16	4.27E-16	4.27E-16	2.47E-16	1.16E-16	6.96E-17	6.96E-17	6.96E-17	6.96E-17	6.96E-17	6.96E-17
Mar	2.08E-16	1.22E-16	7.08E-16	7.08E-16	1.76E-15	1.89E-15	1.89E-15	1.89E-15	1.89E-15	1.89E-15	1.89E-15	1.89E-15	1.89E-15	1.89E-15	1.89E-15	1.89E-15	1.89E-15	1.89E-15	1.89E-15	1.89E-15	1.89E-15	1.89E-15	1.89E-15	1.89E-15	1.89E-15
Apr	1.39E-16	8.20E-15	5.04E-15	5.04E-15	5.04E-15	5.04E-15	5.04E-15	5.04E-15	5.04E-15	5.04E-15	5.04E-15	5.04E-15	5.04E-15	5.04E-15	5.04E-15	5.04E-15	5.04E-15	5.04E-15	5.04E-15	5.04E-15	5.04E-15	5.04E-15	5.04E-15	5.04E-15	5.04E-15
May	2.39E-15	9.54E-14	3.82E-14	3.82E-14	6.11E-13	2.44E-13	9.77E-12	3.91E-12	1.86E-12	6.26E-12	2.50E-11	1.00E-11	4.00E-10	1.68E-10	6.04E-09	2.36E-08	1.02E-07	4.10E-06	1.66E-06	6.59E-06	2.62E-05	1.05E-04	4.20E-04	1.68E-04	5.29E-04
Jun	9.05E-15	9.05E-15	9.05E-15	9.05E-15	9.05E-15	9.05E-15	9.05E-15	9.05E-15	9.05E-15	9.05E-15	9.05E-15	9.05E-15	9.05E-15	9.05E-15	9.05E-15	9.05E-15	9.05E-15	9.05E-15	9.05E-15	9.05E-15	9.05E-15	9.05E-15	9.05E-15	9.05E-15	9.05E-15
Jul	2.81E-15	1.63E-15	9.31E-14	5.57E-14	3.27E-14	1.59E-14	1.44E-14	6.79E-14	7.24E-14	4.65E-14	2.79E-14	1.42E-13	8.44E-13	5.04E-13	1.88E-12	1.08E-12	6.48E-11	3.90E-11	2.33E-11	1.43E-11	8.74E-11	5.42E-10	3.43E-10	2.24E-10	1.53E-10
Aug	4.61E-16	2.77E-16	1.66E-16	9.90E-15	5.70E-15	3.89E-15	2.15E-15	1.20E-15	9.98E-15	5.47E-15	2.99E-15	1.67E-15	1.00E-14	6.02E-13	3.61E-13	2.17E-13	1.30E-13	7.81E-12	4.68E-12	2.81E-12	1.70E-12	9.83E-11	5.77E-11	3.44E-11	2.21E-11
Sep	1.68E-16	8.68E-15	4.59E-15	2.4E-15	1.23E-15	6.49E-15	3.45E-14	1.87E-14	1.87E-14	1.87E-14	1.87E-14	1.87E-14	1.87E-14	1.87E-14	1.87E-14	1.87E-14	1.87E-14	1.87E-14	1.87E-14	1.87E-14	1.87E-14	1.87E-14	1.87E-14	1.87E-14	1.87E-14
Oct	2.52E-15	1.30E-15	6.79E-14	3.52E-14	1.87E-14	9.52E-13	2.80E-13	1.45E-13	8.57E-13	4.27E-12	2.43E-12	1.40E-12	8.18E-11	4.83E-11	2.88E-11	1.75E-11	1.05E-11	6.49E-11	4.07E-10	2.63E-10	1.47E-10	7.17E-10	3.44E-09	1.42E-10	6.46E-09
Nov	3.17E-15	1.34E-15	5.78E-14	2.57E-14	1.28E-14	6.50E-13	3.70E-13	1.78E-13	9.06E-12	5.26E-12	1.67E-12	9.60E-11	5.57E-11	3.25E-11	1.92E-11	1.14E-11	6.77E-10	4.07E-10	2.46E-10	1.51E-10	9.44E-09	6.05E-09	3.44E-09	2.05E-09	2.05E-09
Dec	3.44E-09	3.44E-09	3.44E-09	3.44E-09	3.44E-09	3.44E-09	3.44E-09	3.44E-09	3.44E-09	3.44E-09	3.44E-09	3.44E-09	3.44E-09	3.44E-09	3.44E-09	3.44E-09	3.44E-09	3.44E-09	3.44E-09	3.44E-09	3.44E-09	3.44E-09	3.44E-09	3.44E-09	3.44E-09
Jan	2.00E-10	2.00E-10	2.00E-10	2.00E-10	2.00E-10	2.00E-10	2.00E-10	2.00E-10	2.00E-10	2.00E-10	2.00E-10	2.00E-10	2.00E-10	2.00E-10	2.00E-10	2.00E-10	2.00E-10	2.00E-10	2.00E-10	2.00E-10	2.00E-10	2.00E-10	2.00E-10	2.00E-10	2.00E-10
Feb	1.00E-10	1.00E-10	1.00E-10	1.00E-10	1.00E-10	1.00E-10	1.00E-10	1.00E-10	1.00E-10	1.00E-10	1.00E-10	1.00E-10	1.00E-10	1.00E-10	1.00E-10	1.00E-10	1.00E-10	1.00E-10	1.00E-10	1.00E-10	1.00E-10	1.00E-10	1.00E-10	1.00E-10	1.00E-10
Mar	4.62E-09	4.62E-09	4.62E-09	4.62E-09	4.62E-09	4.62E-09	4.62E-09	4.62E-09	4.62E-09	4.62E-09	4.62E-09	4.62E-09	4.62E-09	4.62E-09	4.62E-09	4.62E-09	4.62E-09	4.62E-09	4.62E-09	4.62E-09	4.62E-09	4.62E-09	4.62E-09	4.62E-09	4.62E-09
Apr	9.00E-08	9.00E-08	9.00E-08	9.00E-08	9.00E-08	9.00E-08	9.00E-08	9.00E-08	9.00E-08	9.00E-08	9.00E-08	9.00E-08	9.00E-08	9.00E-08	9.00E-08	9.00E-08	9.00E-08	9.00E-08	9.00E-08	9.00E-08	9.00E-08	9.00E-08	9.00E-08	9.00E-08	9.00E-08
May	1.25E-16	9.18E-15	7.40E-14	6.14E-14	6.14E-14	6.14E-14	6.14E-14	6.14E-14	6.14E-14	6.14E-14	6.14E-14	6.14E-14	6.14E-14	6.14E-14	6.14E-14	6.14E-14	6.14E-14	6.14E-14	6.14E-14	6.14E-14	6.14E-14	6.14E-14	6.14E-14	6.14E-14	6.14E-14
Jun	2.80E-16	1.64E-16	1.01E-16	6.59E-15	4.37E-15	3.40E-15	2.72E-15	2.31E-15	2.07E-15	1.97E-15	1.85E-15	1.80E-15	1.79E-15	1.75E-15	1.73E-15	1.73E-15	1.73E-15	1.73E-15	1.73E-15	1.73E-15	1.73E-15	1.73E-15	1.73E-15	1.73E-15	1.73E-15
Jul	2.73E-16	4.40E-15	2.72E-15	1.73E-15	1.23E-15	9.12E-14	6.21E-14	5.37E-14	5.19E-14	5.19E-14	5.19E-14	5.19E-14	5.19E-14	5.19E-14	5.19E-14	5.19E-14	5.19E-14	5.19E-14	5.19E-14	5.19E-14	5.19E-14	5.19E-14	5.19E-14	5.19E-14	5.19E-14
Aug	7.48E-15	4.40E-15	2.52E-15	1.64E-15	1.41E-15	8.88E-14	6.78E-14	5.17E-14	4.82E-14	4.61E-14	4.61E-14	4.61E-14	4.61E-14	4.61E-14	4.61E-14	4.61E-14	4.61E-14	4.61E-14	4.61E-14	4.61E-14	4.61E-14	4.61E-14	4.61E-14	4.61E-14	4.61E-14
Sep	6.95E-15	4.09E-15	2.52E-15	1.64E-15	1.41E-15	1.43E-15	1.14E-15	8.73E-15	4.82E-14	4.82E-14	4.82E-14	4.82E-14	4.82E-14	4.82E-14	4.82E-14	4.82E-14	4.82E-14	4.82E-14	4.82E-14	4.82E-14	4.82E-14	4.82E-14	4.82E-14	4.82E-14	4.82E-14
Oct	1.18E-16	6.90E-15	2.32E-15	1.39E-15	9.62E-15	7.17E-14	5.73E-14	4.88E-14	4.88E-14	4.88E-14	4.88E-14	4.88E-14	4.88E-14	4.88E-14	4.88E-14	4.88E-14	4.88E-14	4.88E-14	4.88E-14	4.88E-14	4.88E-14	4.88E-14	4.88E-14	4.88E-14	4.88E-14
Nov	5.90E-16	3.46E-15	1.26E-15	7.52E-15	5.29E-15	7.17E-14	5.73E-14	4.88E-14	4.88E-14	4.88E-14	4.88E-14	4.88E-14	4.88E-14	4.88E-14	4.88E-14	4.88E-14	4.88E-14	4.88E-14	4.88E-14	4.88E-14	4.88E-14	4.88E-14	4.88E-14	4.88E-14	4.88E-14
Dec	3.20E-17	1.50E-17	8.30E-16	3.50E-16	3.00E-16	1.91E-16	9.00E-16	7.90E-16	2.97E-15	3.07E-15	3.07E-15	2.53E-15	2.10E-15	2.08E-15	2.08E-15	2.08E-15	2.08E-15	2.08E-15	2.08E-15	2.08E-15	2.08E-15	2.08E-15	2.08E-15	2.08E-15	2.08E-15
Jan	2.50E-17	9.20E-17	4.80E-16	1.80E-16	1.50E-16	9.00E-16	7.90E-16	2.97E-15	3.07E-15	3.07E-15	3.07E-15														

Table S.6 Envelope, Building B (monthly, 33years after completion)

1	7.69E+10	8.18E+10	1.02E+11	1.18E+11	8.66E+10	1.38E+11	1.40E+11	8.82E+10	1.49E+11	1.31E+11	1.27E+11	1.45E+11	1.52E+11	1.28E+11	1.49E+11	1.60E+11	1.62E+11	1.37E+11	1.58E+11	1.70E+11	1.78E+11	1.52E+11	1.75E+11	1.86E+11	1.67E+11	1.91E+11	2.00E+11	1.74E+11	1.96E+11	2.06E+11	1.80E+11	2.02E+11	2.12E+11	1.86E+11	2.08E+11	2.18E+11	1.92E+11	2.18E+11	2.28E+11	2.02E+11	2.28E+11	2.38E+11	2.12E+11	2.38E+11	2.48E+11	2.22E+11	2.48E+11	2.58E+11	2.32E+11	2.58E+11	2.68E+11	2.42E+11	2.68E+11	2.78E+11	2.52E+11	2.78E+11	2.88E+11	2.62E+11	2.88E+11	2.98E+11	2.72E+11	2.98E+11	3.08E+11	2.82E+11	3.08E+11	3.18E+11	2.92E+11	3.18E+11	3.28E+11	3.02E+11	3.28E+11	3.38E+11	3.12E+11	3.38E+11	3.48E+11	3.22E+11	3.48E+11	3.58E+11	3.32E+11	3.58E+11	3.68E+11	3.42E+11	3.68E+11	3.78E+11	3.52E+11	3.78E+11	3.88E+11	3.62E+11	3.88E+11	3.98E+11	3.72E+11	3.98E+11	4.08E+11	3.82E+11	4.08E+11	4.18E+11	3.92E+11	4.18E+11	4.28E+11	4.02E+11	4.28E+11	4.38E+11	4.12E+11	4.38E+11	4.48E+11	4.22E+11	4.48E+11	4.58E+11	4.32E+11	4.58E+11	4.68E+11	4.42E+11	4.68E+11	4.78E+11	4.52E+11	4.78E+11	4.88E+11	4.62E+11	4.88E+11	4.98E+11	4.72E+11	4.98E+11	5.08E+11	4.82E+11	5.08E+11	5.18E+11	4.92E+11	5.18E+11	5.28E+11	5.02E+11	5.28E+11	5.38E+11	5.12E+11	5.38E+11	5.48E+11	5.22E+11	5.48E+11	5.58E+11	5.32E+11	5.58E+11	5.68E+11	5.42E+11	5.68E+11	5.78E+11	5.52E+11	5.78E+11	5.88E+11	5.62E+11	5.88E+11	5.98E+11	5.72E+11	5.98E+11	6.08E+11	5.82E+11	6.08E+11	6.18E+11	5.92E+11	6.18E+11	6.28E+11	6.02E+11	6.28E+11	6.38E+11	6.12E+11	6.38E+11	6.48E+11	6.22E+11	6.48E+11	6.58E+11	6.32E+11	6.58E+11	6.68E+11	6.42E+11	6.68E+11	6.78E+11	6.52E+11	6.78E+11	6.88E+11	6.62E+11	6.88E+11	6.98E+11	6.72E+11	6.98E+11	7.08E+11	6.82E+11	7.08E+11	7.18E+11	6.92E+11	7.18E+11	7.28E+11	7.02E+11	7.28E+11	7.38E+11	7.12E+11	7.38E+11	7.48E+11	7.22E+11	7.48E+11	7.58E+11	7.32E+11	7.58E+11	7.68E+11	7.42E+11	7.68E+11	7.78E+11	7.52E+11	7.78E+11	7.88E+11	7.62E+11	7.88E+11	7.98E+11	7.72E+11	7.98E+11	8.08E+11	7.82E+11	8.08E+11	8.18E+11	7.92E+11	8.18E+11	8.28E+11	8.02E+11	8.28E+11	8.38E+11	8.12E+11	8.38E+11	8.48E+11	8.22E+11	8.48E+11	8.58E+11	8.32E+11	8.58E+11	8.68E+11	8.42E+11	8.68E+11	8.78E+11	8.52E+11	8.78E+11	8.88E+11	8.62E+11	8.88E+11	8.98E+11	8.72E+11	8.98E+11	9.08E+11	8.82E+11	9.08E+11	9.18E+11	8.92E+11	9.18E+11	9.28E+11	9.02E+11	9.28E+11	9.38E+11	9.12E+11	9.38E+11	9.48E+11	9.22E+11	9.48E+11	9.58E+11	9.32E+11	9.58E+11	9.68E+11	9.42E+11	9.68E+11	9.78E+11	9.52E+11	9.78E+11	9.88E+11	9.62E+11	9.88E+11	9.98E+11	9.72E+11	9.98E+11	1.00E+12	9.82E+11	1.00E+12	1.01E+12	1.02E+12	1.03E+12	1.04E+12	1.05E+12	1.06E+12	1.07E+12	1.08E+12	1.09E+12	1.10E+12	1.11E+12	1.12E+12	1.13E+12	1.14E+12	1.15E+12	1.16E+12	1.17E+12	1.18E+12	1.19E+12	1.20E+12	1.21E+12	1.22E+12	1.23E+12	1.24E+12	1.25E+12	1.26E+12	1.27E+12	1.28E+12	1.29E+12	1.30E+12	1.31E+12	1.32E+12	1.33E+12	1.34E+12	1.35E+12	1.36E+12	1.37E+12	1.38E+12	1.39E+12	1.40E+12	1.41E+12	1.42E+12	1.43E+12	1.44E+12	1.45E+12	1.46E+12	1.47E+12	1.48E+12	1.49E+12	1.50E+12	1.51E+12	1.52E+12	1.53E+12	1.54E+12	1.55E+12	1.56E+12	1.57E+12	1.58E+12	1.59E+12	1.60E+12	1.61E+12	1.62E+12	1.63E+12	1.64E+12	1.65E+12	1.66E+12	1.67E+12	1.68E+12	1.69E+12	1.70E+12	1.71E+12	1.72E+12	1.73E+12	1.74E+12	1.75E+12	1.76E+12	1.77E+12	1.78E+12	1.79E+12	1.80E+12	1.81E+12	1.82E+12	1.83E+12	1.84E+12	1.85E+12	1.86E+12	1.87E+12	1.88E+12	1.89E+12	1.90E+12	1.91E+12	1.92E+12	1.93E+12	1.94E+12	1.95E+12	1.96E+12	1.97E+12	1.98E+12	1.99E+12	2.00E+12
---	----------	----------	----------	----------	----------	----------	----------	----------	----------	----------	----------	----------	----------	----------	----------	----------	----------	----------	----------	----------	----------	----------	----------	----------	----------	----------	----------	----------	----------	----------	----------	----------	----------	----------	----------	----------	----------	----------	----------	----------	----------	----------	----------	----------	----------	----------	----------	----------	----------	----------	----------	----------	----------	----------	----------	----------	----------	----------	----------	----------	----------	----------	----------	----------	----------	----------	----------	----------	----------	----------	----------	----------	----------	----------	----------	----------	----------	----------	----------	----------	----------	----------	----------	----------	----------	----------	----------	----------	----------	----------	----------	----------	----------	----------	----------	----------	----------	----------	----------	----------	----------	----------	----------	----------	----------	----------	----------	----------	----------	----------	----------	----------	----------	----------	----------	----------	----------	----------	----------	----------	----------	----------	----------	----------	----------	----------	----------	----------	----------	----------	----------	----------	----------	----------	----------	----------	----------	----------	----------	----------	----------	----------	----------	----------	----------	----------	----------	----------	----------	----------	----------	----------	----------	----------	----------	----------	----------	----------	----------	----------	----------	----------	----------	----------	----------	----------	----------	----------	----------	----------	----------	----------	----------	----------	----------	----------	----------	----------	----------	----------	----------	----------	----------	----------	----------	----------	----------	----------	----------	----------	----------	----------	----------	----------	----------	----------	----------	----------	----------	----------	----------	----------	----------	----------	----------	----------	----------	----------	----------	----------	----------	----------	----------	----------	----------	----------	----------	----------	----------	----------	----------	----------	----------	----------	----------	----------	----------	----------	----------	----------	----------	----------	----------	----------	----------	----------	----------	----------	----------	----------	----------	----------	----------	----------	----------	----------	----------	----------	----------	----------	----------	----------	----------	----------	----------	----------	----------	----------	----------	----------	----------	----------	----------	----------	----------	----------	----------	----------	----------	----------	----------	----------	----------	----------	----------	----------	----------	----------	----------	----------	----------	----------	----------	----------	----------	----------	----------	----------	----------	----------	----------	----------	----------	----------	----------	----------	----------	----------	----------	----------	----------	----------	----------	----------	----------	----------	----------	----------	----------	----------	----------	----------	----------	----------	----------	----------	----------	----------	----------	----------	----------	----------	----------	----------	----------	----------	----------	----------	----------	----------	----------	----------	----------	----------	----------	----------	----------	----------	----------	----------	----------	----------	----------	----------	----------	----------	----------	----------	----------	----------	----------	----------	----------	----------	----------	----------	----------	----------	----------	----------	----------	----------	----------	----------	----------	----------	----------	----------	----------	----------	----------	----------	----------	----------	----------

Table S.7 Envelope, Building B (hourly, June 21th, 33years after completion)

Year	1	2	3	4	5	6	7	8	9	10	11	12	13	14	15	16	17	18	19	20	21	22	23	24	
1988-06-01	0	0	0	0	0	0	0	0	0	0	0	0	0	0	0	0	0	0	0	0	0	0	0	0	0
1988-06-02	0	0	0	0	0	0	0	0	0	0	0	0	0	0	0	0	0	0	0	0	0	0	0	0	0
1988-06-03	0	0	0	0	0	0	0	0	0	0	0	0	0	0	0	0	0	0	0	0	0	0	0	0	0
1988-06-04	0	0	0	0	0	0	0	0	0	0	0	0	0	0	0	0	0	0	0	0	0	0	0	0	0
1988-06-05	0	0	0	0	0	0	0	0	0	0	0	0	0	0	0	0	0	0	0	0	0	0	0	0	0
1988-06-06	0	0	0	0	0	0	0	0	0	0	0	0	0	0	0	0	0	0	0	0	0	0	0	0	0
1988-06-07	0	0	0	0	0	0	0	0	0	0	0	0	0	0	0	0	0	0	0	0	0	0	0	0	0
1988-06-08	0	0	0	0	0	0	0	0	0	0	0	0	0	0	0	0	0	0	0	0	0	0	0	0	0
1988-06-09	0	0	0	0	0	0	0	0	0	0	0	0	0	0	0	0	0	0	0	0	0	0	0	0	0
1988-06-10	0	0	0	0	0	0	0	0	0	0	0	0	0	0	0	0	0	0	0	0	0	0	0	0	0
1988-06-11	0	0	0	0	0	0	0	0	0	0	0	0	0	0	0	0	0	0	0	0	0	0	0	0	0
1988-06-12	0	0	0	0	0	0	0	0	0	0	0	0	0	0	0	0	0	0	0	0	0	0	0	0	0
1988-06-13	0	0	0	0	0	0	0	0	0	0	0	0	0	0	0	0	0	0	0	0	0	0	0	0	0
1988-06-14	0	0	0	0	0	0	0	0	0	0	0	0	0	0	0	0	0	0	0	0	0	0	0	0	0
1988-06-15	0	0	0	0	0	0	0	0	0	0	0	0	0	0	0	0	0	0	0	0	0	0	0	0	0
1988-06-16	0	0	0	0	0	0	0	0	0	0	0	0	0	0	0	0	0	0	0	0	0	0	0	0	0
1988-06-17	0	0	0	0	0	0	0	0	0	0	0	0	0	0	0	0	0	0	0	0	0	0	0	0	0
1988-06-18	0	0	0	0	0	0	0	0	0	0	0	0	0	0	0	0	0	0	0	0	0	0	0	0	0
1988-06-19	0	0	0	0	0	0	0	0	0	0	0	0	0	0	0	0	0	0	0	0	0	0	0	0	0
1988-06-20	0	0	0	0	0	0	0	0	0	0	0	0	0	0	0	0	0	0	0	0	0	0	0	0	0
1988-06-21	0	0	0	0	0	0	0	0	0	0	0	0	0	0	0	0	0	0	0	0	0	0	0	0	0
1988-06-22	0	0	0	0	0	0	0	0	0	0	0	0	0	0	0	0	0	0	0	0	0	0	0	0	0
1988-06-23	0	0	0	0	0	0	0	0	0	0	0	0	0	0	0	0	0	0	0	0	0	0	0	0	0
1988-06-24	0	0	0	0	0	0	0	0	0	0	0	0	0	0	0	0	0	0	0	0	0	0	0	0	0
1988-06-25	0	0	0	0	0	0	0	0	0	0	0	0	0	0	0	0	0	0	0	0	0	0	0	0	0
1988-06-26	0	0	0	0	0	0	0	0	0	0	0	0	0	0	0	0	0	0	0	0	0	0	0	0	0
1988-06-27	0	0	0	0	0	0	0	0	0	0	0	0	0	0	0	0	0	0	0	0	0	0	0	0	0
1988-06-28	0	0	0	0	0	0	0	0	0	0	0	0	0	0	0	0	0	0	0	0	0	0	0	0	0
1988-06-29	0	0	0	0	0	0	0	0	0	0	0	0	0	0	0	0	0	0	0	0	0	0	0	0	0
1988-06-30	0	0	0	0	0	0	0	0	0	0	0	0	0	0	0	0	0	0	0	0	0	0	0	0	0
1988-06-30	0	0	0	0	0	0	0	0	0	0	0	0	0	0	0	0	0	0	0	0	0	0	0	0	0

Table S.8 Envelope, Building B (hourly, December 21th, 33years after completion)

Year	Month	Day	Hour	Temp (C)	Temp (F)	Humidity (%)	Wind Speed (m/s)	Wind Dir (deg)	Cloud Cover (%)	Solar Rad (W/m2)	Global Rad (kWh/m2)	Diffuse Rad (kWh/m2)	Direct Rad (kWh/m2)
1	12	21	0	1.05E+01	53.1	0.65	1.5	135	0.5	150	0.00	0.00	0.00
1	12	21	1	1.05E+01	53.1	0.65	1.5	135	0.5	150	0.00	0.00	0.00
1	12	21	2	1.05E+01	53.1	0.65	1.5	135	0.5	150	0.00	0.00	0.00
1	12	21	3	1.05E+01	53.1	0.65	1.5	135	0.5	150	0.00	0.00	0.00
1	12	21	4	1.05E+01	53.1	0.65	1.5	135	0.5	150	0.00	0.00	0.00
1	12	21	5	1.05E+01	53.1	0.65	1.5	135	0.5	150	0.00	0.00	0.00
1	12	21	6	1.05E+01	53.1	0.65	1.5	135	0.5	150	0.00	0.00	0.00
1	12	21	7	1.05E+01	53.1	0.65	1.5	135	0.5	150	0.00	0.00	0.00
1	12	21	8	1.05E+01	53.1	0.65	1.5	135	0.5	150	0.00	0.00	0.00
1	12	21	9	1.05E+01	53.1	0.65	1.5	135	0.5	150	0.00	0.00	0.00
1	12	21	10	1.05E+01	53.1	0.65	1.5	135	0.5	150	0.00	0.00	0.00
1	12	21	11	1.05E+01	53.1	0.65	1.5	135	0.5	150	0.00	0.00	0.00
1	12	21	12	1.05E+01	53.1	0.65	1.5	135	0.5	150	0.00	0.00	0.00
1	12	21	13	1.05E+01	53.1	0.65	1.5	135	0.5	150	0.00	0.00	0.00
1	12	21	14	1.05E+01	53.1	0.65	1.5	135	0.5	150	0.00	0.00	0.00
1	12	21	15	1.05E+01	53.1	0.65	1.5	135	0.5	150	0.00	0.00	0.00
1	12	21	16	1.05E+01	53.1	0.65	1.5	135	0.5	150	0.00	0.00	0.00
1	12	21	17	1.05E+01	53.1	0.65	1.5	135	0.5	150	0.00	0.00	0.00
1	12	21	18	1.05E+01	53.1	0.65	1.5	135	0.5	150	0.00	0.00	0.00
1	12	21	19	1.05E+01	53.1	0.65	1.5	135	0.5	150	0.00	0.00	0.00
1	12	21	20	1.05E+01	53.1	0.65	1.5	135	0.5	150	0.00	0.00	0.00
1	12	21	21	1.05E+01	53.1	0.65	1.5	135	0.5	150	0.00	0.00	0.00
1	12	21	22	1.05E+01	53.1	0.65	1.5	135	0.5	150	0.00	0.00	0.00
1	12	21	23	1.05E+01	53.1	0.65	1.5	135	0.5	150	0.00	0.00	0.00
1	12	21	24	1.05E+01	53.1	0.65	1.5	135	0.5	150	0.00	0.00	0.00

Table S.9 Envelope, Building A (yearly, 50 years)

	1	2	3	4	5	6	7	8	9	10	11	12	13	14	15	16	17	18	19	20	21	22	23	24	25	
<i>Area</i>	537E+10	537E+10	537E+10	537E+10	537E+10	537E+10	537E+10	537E+10	537E+10	537E+10	537E+10	537E+10	537E+10	537E+10	537E+10	537E+10	537E+10	537E+10	537E+10	537E+10	537E+10	537E+10	537E+10	537E+10	537E+10	
<i>Area</i>	506E+11	506E+11	506E+11	506E+11	506E+11	506E+11	506E+11	506E+11	506E+11	506E+11	506E+11	506E+11	506E+11	506E+11	506E+11	506E+11	506E+11	506E+11	506E+11	506E+11	506E+11	506E+11	506E+11	506E+11	506E+11	
<i>Area</i>	879E+07	879E+07	879E+07	879E+07	879E+07	879E+07	879E+07	879E+07	879E+07	879E+07	879E+07	879E+07	879E+07	879E+07	879E+07	879E+07	879E+07	879E+07	879E+07	879E+07	879E+07	879E+07	879E+07	879E+07	879E+07	
<i>Area</i>	822E+08	822E+08	822E+08	822E+08	822E+08	822E+08	822E+08	822E+08	822E+08	822E+08	822E+08	822E+08	822E+08	822E+08	822E+08	822E+08	822E+08	822E+08	822E+08	822E+08	822E+08	822E+08	822E+08	822E+08	822E+08	
<i>Area</i>	200E+08	200E+08	200E+08	200E+08	200E+08	200E+08	200E+08	200E+08	200E+08	200E+08	200E+08	200E+08	200E+08	200E+08	200E+08	200E+08	200E+08	200E+08	200E+08	200E+08	200E+08	200E+08	200E+08	200E+08	200E+08	
<i>Area</i>	166E+16	141E+16	119E+16	101E+16	838E+15	729E+15	620E+15	527E+15	449E+15	383E+15	327E+15	279E+15	239E+15	205E+15	176E+15	151E+15	131E+15	113E+15	981E+14	858E+14	747E+14	655E+14	578E+14	458E+14	458E+14	
<i>Area</i>	309E+16	271E+16	230E+16	190E+16	160E+16	141E+16	120E+16	102E+16	868E+15	738E+15	627E+15	533E+15	458E+15	392E+15	327E+15	278E+15	237E+15	201E+15	171E+15	145E+15	124E+15	109E+15	920E+14	788E+14	645E+14	645E+14
<i>Area</i>	577E+15	509E+15	446E+15	378E+15	310E+15	253E+15	207E+15	169E+15	139E+15	114E+15	92E+14	778E+14	664E+14	569E+14	486E+14	416E+14	358E+14	309E+14	265E+14	228E+14	197E+14	166E+14	142E+14	122E+14	105E+14	91E+14
<i>Area</i>	730E+15	582E+15	446E+15	329E+15	208E+15	140E+15	92E+14	53E+14	32E+14	19E+14	11E+14	6E+14	3E+14	2E+14	1E+14	1E+14	1E+14	1E+14	1E+14	1E+14	1E+14	1E+14	1E+14	1E+14	1E+14	1E+14
<i>Area</i>	639E+15	547E+15	447E+15	369E+15	304E+15	252E+15	208E+15	172E+15	143E+15	119E+15	98E+14	82E+14	69E+14	57E+14	47E+14	39E+14	32E+14	26E+14	21E+14	17E+14	14E+14	12E+14	10E+14	8E+14	6E+14	6E+14
<i>Area</i>	635E+14	448E+14	311E+14	218E+14	152E+14	107E+14	747E+13	522E+13	366E+13	256E+13	179E+13	128E+13	87E+13	59E+13	39E+13	26E+13	18E+13	12E+13	8E+13	5E+13	3E+13	2E+13	1E+13	1E+13	1E+13	1E+13
<i>Area</i>	624E+14	624E+14	602E+14	602E+14	602E+14	602E+14	602E+14	602E+14	602E+14	602E+14	602E+14	602E+14	602E+14	602E+14	602E+14	602E+14	602E+14	602E+14	602E+14	602E+14	602E+14	602E+14	602E+14	602E+14	602E+14	602E+14
<i>Area</i>	238E+15	238E+15	202E+15	172E+15	146E+15	126E+15	106E+15	897E+14	72E+14	64E+14	53E+14	44E+14	36E+14	29E+14	23E+14	18E+14	14E+14	11E+14	8E+14	6E+14	4E+14	3E+14	2E+14	1E+14	1E+14	1E+14
<i>Area</i>	607E+14	41E+14	338E+14	30E+14	245E+14	222E+14	211E+14	190E+14	172E+14	158E+14	142E+14	128E+14	116E+14	105E+14	92E+14	81E+14	72E+14	65E+14	59E+14	54E+14	49E+14	45E+14	41E+14	37E+14	34E+14	31E+14
<i>Area</i>	601E+14	51E+14	408E+14	326E+14	262E+14	211E+14	170E+14	138E+14	112E+14	92E+14	76E+14	63E+14	53E+14	45E+14	39E+14	34E+14	30E+14	27E+14	24E+14	21E+14	19E+14	17E+14	15E+14	14E+14	12E+14	11E+14
<i>Area</i>	10E+10	10E+10	10E+10	10E+10	10E+10	10E+10	10E+10	10E+10	10E+10	10E+10	10E+10	10E+10	10E+10	10E+10	10E+10	10E+10	10E+10	10E+10	10E+10	10E+10	10E+10	10E+10	10E+10	10E+10	10E+10	10E+10
<i>Area</i>	319E+10	319E+10	319E+10	319E+10	319E+10	319E+10	319E+10	319E+10	319E+10	319E+10	319E+10	319E+10	319E+10	319E+10	319E+10	319E+10	319E+10	319E+10	319E+10	319E+10	319E+10	319E+10	319E+10	319E+10	319E+10	319E+10
<i>Area</i>	130E+10	130E+10	130E+10	130E+10	130E+10	130E+10	130E+10	130E+10	130E+10	130E+10	130E+10	130E+10	130E+10	130E+10	130E+10	130E+10	130E+10	130E+10	130E+10	130E+10	130E+10	130E+10	130E+10	130E+10	130E+10	130E+10
<i>Area</i>	339E+09	339E+09	339E+09	339E+09	339E+09	339E+09	339E+09	339E+09	339E+09	339E+09	339E+09	339E+09	339E+09	339E+09	339E+09	339E+09	339E+09	339E+09	339E+09	339E+09	339E+09	339E+09	339E+09	339E+09	339E+09	339E+09
<i>Area</i>	438E+09	438E+09	438E+09	438E+09	438E+09	438E+09	438E+09	438E+09	438E+09	438E+09	438E+09	438E+09	438E+09	438E+09	438E+09	438E+09	438E+09	438E+09	438E+09	438E+09	438E+09	438E+09	438E+09	438E+09	438E+09	438E+09
<i>Area</i>	438E+09	438E+09	438E+09	438E+09	438E+09	438E+09	438E+09	438E+09	438E+09	438E+09	438E+09	438E+09	438E+09	438E+09	438E+09	438E+09	438E+09	438E+09	438E+09	438E+09	438E+09	438E+09	438E+09	438E+09	438E+09	438E+09
<i>Area</i>	740E+15	630E+15	519E+15	436E+15	370E+15	310E+15	262E+15	222E+15	188E+15	160E+15	137E+15	117E+15	101E+15	87E+15	75E+15	65E+15	57E+15	507E+14	449E+14	408E+14	358E+14	320E+14	294E+14	269E+14	249E+14	230E+14

Table S.10 Envelope, Building A (monthly, 33years after completion)

Month	1	2	3	4	5	6	7	8	9	10	11	12	13	14	15	16	17	18	19	20	21	22	23	24	
<i>Jan</i>	678E+10	718E+10	839E+10	1.04E+11	7.61E+10	1.21E+11	1.23E+11	7.79E+10	1.31E+11	1.31E+11	1.12E+11	1.33E+11	1.33E+11	1.13E+11	1.31E+11	1.31E+11	1.09E+11	1.40E+11	1.37E+11	1.04E+11	1.46E+11	1.46E+11	1.53E+11	1.32E+11	1.28E+11
<i>Feb</i>	614E+09	5.26E+09	7.52E+09	8.86E+09	7.90E+09	8.00E+09	1.06E+10	1.26E+10	1.32E+10	1.35E+10	1.20E+10	1.36E+10	1.36E+10	1.13E+10	1.31E+10	1.31E+10	1.08E+10	1.40E+10	1.37E+10	1.04E+10	1.46E+10	1.46E+10	1.53E+10	1.32E+10	1.28E+10
<i>Mar</i>	1.84E+09	1.96E+09	1.58E+09	2.46E+09	2.14E+09	1.86E+09	1.68E+09	2.58E+09	2.58E+09	2.20E+09	2.05E+09	2.26E+09	2.26E+09	1.90E+09	2.27E+09	2.27E+09	1.86E+09	2.40E+09	2.37E+09	1.80E+09	2.52E+09	2.52E+09	2.15E+09	1.34E+09	1.44E+09
<i>Apr</i>	1.53E+09	1.16E+09	1.53E+09	1.83E+09	1.51E+09	1.69E+09	1.69E+09	1.92E+09	1.92E+09	1.68E+09	1.51E+09	1.62E+09	1.62E+09	1.28E+09	1.60E+09	1.60E+09	1.33E+09	1.72E+09	1.69E+09	1.33E+09	1.83E+09	1.83E+09	1.38E+09	1.12E+09	1.21E+09
<i>May</i>	5.31E+08	4.59E+08	7.02E+08	6.84E+08	6.50E+08	7.02E+08	6.99E+08	6.99E+08	6.50E+08	6.50E+08	5.88E+08	6.50E+08	6.50E+08	5.28E+08	6.50E+08	6.50E+08	4.88E+08	6.50E+08	6.50E+08	4.88E+08	6.50E+08	6.50E+08	4.88E+08	3.66E+08	4.36E+08
<i>Jun</i>	8.44E+08	8.29E+08	8.12E+08	1.18E+09	1.12E+09	1.58E+09	1.58E+09	1.58E+09	1.12E+09	1.12E+09	1.07E+09	1.12E+09	1.12E+09	9.26E+08	1.12E+09	1.12E+09	8.52E+08	1.12E+09	1.12E+09	8.52E+08	1.12E+09	1.12E+09	8.52E+08	6.06E+08	7.28E+08
<i>Jul</i>	5.66E+08	0	5.78E+08	7.29E+08	6.77E+08	5.72E+08	7.61E+08	7.86E+08	4.05E+08	6.98E+08	6.13E+08	6.87E+08	6.87E+08	5.88E+08	5.93E+08	5.93E+08	4.26E+08	6.21E+08	6.21E+08	4.26E+08	6.21E+08	6.21E+08	4.26E+08	3.00E+08	4.42E+08
<i>Aug</i>	1.64E+08	1.41E+08	1.85E+08	2.28E+08	1.87E+08	1.58E+08	2.14E+08	2.14E+08	1.48E+08	3.31E+08	2.99E+08	2.99E+08	2.74E+08	2.74E+08	2.21E+08	2.21E+08	1.12E+08	2.45E+08	2.45E+08	1.12E+08	2.45E+08	2.45E+08	1.12E+08	8.00E+07	1.01E+08
<i>Sep</i>	1.58E+06	1.51E+06	4.89E+06	2.24E+06	3.72E+06	1.07E+07	1.18E+07	1.18E+07	1.86E+07	1.86E+07	1.52E+07	1.68E+07	1.68E+07	1.46E+07	1.68E+07	1.68E+07	1.12E+07	1.68E+07	1.68E+07	1.12E+07	1.68E+07	1.68E+07	1.12E+07	8.00E+05	1.01E+06
<i>Oct</i>	2.79E+06	1.29E+06	1.29E+06	5.79E+06	3.26E+06	1.79E+06	1.29E+06	1.29E+06	3.66E+06	3.66E+06	3.06E+06	3.66E+06	3.66E+06	3.06E+06	3.66E+06	3.66E+06	2.26E+06	3.66E+06	3.66E+06	2.26E+06	3.66E+06	3.66E+06	2.26E+06	1.29E+06	1.39E+06
<i>Nov</i>	3.66E+12	3.66E+12	3.66E+12	3.66E+12	3.66E+12	3.66E+12	3.66E+12	3.66E+12	3.66E+12	3.66E+12	3.66E+12	3.66E+12	3.66E+12	3.66E+12	3.66E+12	3.66E+12	3.66E+12	3.66E+12	3.66E+12	3.66E+12	3.66E+12	3.66E+12	3.66E+12	3.66E+12	3.66E+12
<i>Dec</i>	2.91E+13	2.91E+13	2.91E+13	2.91E+13	2.91E+13	2.91E+13	2.91E+13	2.91E+13	2.91E+13	2.91E+13	2.91E+13	2.91E+13	2.91E+13	2.91E+13	2.91E+13	2.91E+13	2.91E+13	2.91E+13	2.91E+13	2.91E+13	2.91E+13	2.91E+13	2.91E+13	2.91E+13	2.91E+13
<i>Jan</i>	1.45E+13	1.45E+13	1.45E+13	1.45E+13	1.45E+13	1.45E+13	1.45E+13	1.45E+13	1.45E+13	1.45E+13	1.45E+13	1.45E+13	1.45E+13	1.45E+13	1.45E+13	1.45E+13	1.45E+13	1.45E+13	1.45E+13	1.45E+13	1.45E+13	1.45E+13	1.45E+13	1.45E+13	1.45E+13
<i>Feb</i>	1.45E+13	1.45E+13	1.45E+13	1.45E+13	1.45E+13	1.45E+13	1.45E+13	1.45E+13	1.45E+13	1.45E+13	1.45E+13	1.45E+13	1.45E+13	1.45E+13	1.45E+13	1.45E+13	1.45E+13	1.45E+13	1.45E+13	1.45E+13	1.45E+13	1.45E+13	1.45E+13	1.45E+13	1.45E+13
<i>Mar</i>	1.45E+13	1.45E+13	1.45E+13	1.45E+13	1.45E+13	1.45E+13	1.45E+13	1.45E+13	1.45E+13	1.45E+13	1.45E+13	1.45E+13	1.45E+13	1.45E+13	1.45E+13	1.45E+13	1.45E+13	1.45E+13	1.45E+13	1.45E+13	1.45E+13	1.45E+13	1.45E+13	1.45E+13	1.45E+13
<i>Apr</i>	1.45E+13	1.45E+13	1.45E+13	1.45E+13	1.45E+13	1.45E+13	1.45E+13	1.45E+13	1.45E+13	1.45E+13	1.45E+13	1.45E+13	1.45E+13	1.45E+13	1.45E+13	1.45E+13	1.45E+13	1.45E+13	1.45E+13	1.45E+13	1.45E+13	1.45E+13	1.45E+13	1.45E+13	1.45E+13
<i>May</i>	1.45E+13	1.45E+13	1.45E+13	1.45E+13	1.45E+13	1.45E+13	1.45E+13	1.45E+13	1.45E+13	1.45E+13	1.45E+13	1.45E+13	1.45E+13	1.45E+13	1.45E+13	1.45E+13	1.45E+13	1.45E+13	1.45E+13	1.45E+13	1.45E+13	1.45E+13	1.45E+13	1.45E+13	1.45E+13
<i>Jun</i>	1.45E+13	1.45E+13	1.45E+13	1.45E+13	1.45E+13	1.45E+13	1.45E+13	1.45E+13	1.45E+13	1.45E+13	1.45E+13	1.45E+13	1.45E+13	1.45E+13	1.45E+13	1.45E+13	1.45E+13	1.45E+13	1.45E+13	1.45E+13	1.45E+13	1.45E+13	1.45E+13	1.45E+13	1.45E+13
<i>Jul</i>	1.45E+13	1.45E+13	1.45E+13	1.45E+13	1.45E+13	1.45E+13	1.45E+13	1.45E+13	1.45E+13	1.45E+13	1.45E+13	1.45E+13	1.45E+13	1.45E+13	1.45E+13	1.45E+13	1.45E+13	1.45E+13	1.45E+13	1.45E+13	1.45E+13	1.45E+13	1.45E+13	1.45E+13	1.45E+13
<i>Aug</i>	1.45E+13	1.45E+13	1.45E+13	1.45E+13	1.45E+13	1.45E+13	1.45E+13	1.45E+13	1.45E+13	1.45E+13	1.45E+13	1.45E+13	1.45E+13	1.45E+13	1.45E+13	1.45E+13	1.45E+13	1.45E+13	1.45E+13	1.45E+13	1.45E+13	1.45E+13	1.45E+13	1.45E+13	1.45E+13
<i>Sep</i>	1.45E+13	1.45E+13	1.45E+13	1.45E+13	1.45E+13	1.45E+13	1.45E+13	1.45E+13	1.45E+13	1.45E+13	1.45E+13	1.45E+13	1.45E+13	1.45E+13	1.45E+13	1.45E+13	1.45E+13	1.45E+13	1.45E+13	1.45E+13	1.45E+13	1.45E+13	1.45E+13	1.45E+13	1.45E+13
<i>Oct</i>	1.45E+13	1.45E+13	1.45E+13	1.45E+13	1.45E+13	1.45E+13	1.45E+13	1.45E+13	1.45E+13	1.45E+13	1.45E+13	1.45E+13	1.45E+13	1.45E+13	1.45E+13	1.45E+13	1.45E+13	1.45E+13	1.45E+13	1.45E+13	1.45E+13	1.45E+13	1.45E+13	1.45E+13	1.45E+13
<i>Nov</i>	1.45E+13	1.45E+13	1.45E+13	1.45E+13	1.45E+13	1.45E+13	1.45E+13	1.45E+13	1.45E+13	1.45E+13	1.45E+13	1.45E+13	1.45E+13	1.45E+13	1.45E+13	1.45E+13	1.45E+13	1.45E+13	1.45E+13	1.45E+13	1.45E+13	1.45E+13	1.45E+13	1.45E+13	1.45E+13
<i>Dec</i>	1.45E+13	1.45E+13	1.45E+13	1.45E+13	1.45E+13	1.45E+13	1.45E+13	1.45E+13	1.45E+13	1.45E+13	1.45E+13	1.45E+13	1.45E+13	1.45E+13	1.45E+13	1.45E+13	1.45E+13	1.45E+13	1.45E+13	1.45E+13	1.45E+13	1.45E+13	1.45E+13	1.45E+13	1.45E+13

Table S.10 CONT.

Table with 40 columns (numbered 25-64) and multiple rows of numerical data. The table is oriented vertically in the image. Columns 25-64 contain numerical values, often with trailing zeros, representing different data series or parameters. Each row represents a specific entry or measurement.

Table S.11 Envelope, Building A (hourly, June 21th, 33years after completion)

1	0	2	3	4	5	6	7	8	9	10	11	12	13	14	15	16	17	18	19	20	21	22	23	24
1	0	2	3	4	5	6	7	8	9	10	11	12	13	14	15	16	17	18	19	20	21	22	23	24
2	0	2	3	4	5	6	7	8	9	10	11	12	13	14	15	16	17	18	19	20	21	22	23	24
3	0	2	3	4	5	6	7	8	9	10	11	12	13	14	15	16	17	18	19	20	21	22	23	24
4	0	2	3	4	5	6	7	8	9	10	11	12	13	14	15	16	17	18	19	20	21	22	23	24
5	0	2	3	4	5	6	7	8	9	10	11	12	13	14	15	16	17	18	19	20	21	22	23	24
6	0	2	3	4	5	6	7	8	9	10	11	12	13	14	15	16	17	18	19	20	21	22	23	24
7	0	2	3	4	5	6	7	8	9	10	11	12	13	14	15	16	17	18	19	20	21	22	23	24
8	0	2	3	4	5	6	7	8	9	10	11	12	13	14	15	16	17	18	19	20	21	22	23	24
9	0	2	3	4	5	6	7	8	9	10	11	12	13	14	15	16	17	18	19	20	21	22	23	24
10	0	2	3	4	5	6	7	8	9	10	11	12	13	14	15	16	17	18	19	20	21	22	23	24
11	0	2	3	4	5	6	7	8	9	10	11	12	13	14	15	16	17	18	19	20	21	22	23	24
12	0	2	3	4	5	6	7	8	9	10	11	12	13	14	15	16	17	18	19	20	21	22	23	24
13	0	2	3	4	5	6	7	8	9	10	11	12	13	14	15	16	17	18	19	20	21	22	23	24
14	0	2	3	4	5	6	7	8	9	10	11	12	13	14	15	16	17	18	19	20	21	22	23	24
15	0	2	3	4	5	6	7	8	9	10	11	12	13	14	15	16	17	18	19	20	21	22	23	24
16	0	2	3	4	5	6	7	8	9	10	11	12	13	14	15	16	17	18	19	20	21	22	23	24
17	0	2	3	4	5	6	7	8	9	10	11	12	13	14	15	16	17	18	19	20	21	22	23	24
18	0	2	3	4	5	6	7	8	9	10	11	12	13	14	15	16	17	18	19	20	21	22	23	24
19	0	2	3	4	5	6	7	8	9	10	11	12	13	14	15	16	17	18	19	20	21	22	23	24
20	0	2	3	4	5	6	7	8	9	10	11	12	13	14	15	16	17	18	19	20	21	22	23	24
21	0	2	3	4	5	6	7	8	9	10	11	12	13	14	15	16	17	18	19	20	21	22	23	24
22	0	2	3	4	5	6	7	8	9	10	11	12	13	14	15	16	17	18	19	20	21	22	23	24
23	0	2	3	4	5	6	7	8	9	10	11	12	13	14	15	16	17	18	19	20	21	22	23	24
24	0	2	3	4	5	6	7	8	9	10	11	12	13	14	15	16	17	18	19	20	21	22	23	24

Table S.12 Envelope, Building A (hourly, December 21th, 33years after completion)

Area	1	2	3	4	5	6	7	8	9	10	11	12	13	14	15	16	17	18	19	20	21	22	23	24	
Area 1	5.10E+06	5.07E+06	5.10E+06	5.07E+06	5.07E+06	5.10E+06	5.07E+06	5.07E+06	5.10E+06	5.07E+06	5.07E+06	5.10E+06	5.07E+06	5.07E+06	5.10E+06	5.07E+06	5.07E+06	5.10E+06	5.07E+06	5.07E+06	5.10E+06	5.07E+06	5.07E+06	5.10E+06	5.07E+06
Area 2	0	0	0	0	0	0	0	0	0	0	0	0	0	0	0	0	0	0	0	0	0	0	0	0	0
Area 3	0	0	0	0	0	0	0	0	0	0	0	0	0	0	0	0	0	0	0	0	0	0	0	0	0
Area 4	0	0	0	0	0	0	0	0	0	0	0	0	0	0	0	0	0	0	0	0	0	0	0	0	0
Area 5	0	0	0	0	0	0	0	0	0	0	0	0	0	0	0	0	0	0	0	0	0	0	0	0	0
Area 6	0	0	0	0	0	0	0	0	0	0	0	0	0	0	0	0	0	0	0	0	0	0	0	0	0
Area 7	0	0	0	0	0	0	0	0	0	0	0	0	0	0	0	0	0	0	0	0	0	0	0	0	0
Area 8	0	0	0	0	0	0	0	0	0	0	0	0	0	0	0	0	0	0	0	0	0	0	0	0	0
Area 9	0	0	0	0	0	0	0	0	0	0	0	0	0	0	0	0	0	0	0	0	0	0	0	0	0
Area 10	0	0	0	0	0	0	0	0	0	0	0	0	0	0	0	0	0	0	0	0	0	0	0	0	0
Area 11	0	0	0	0	0	0	0	0	0	0	0	0	0	0	0	0	0	0	0	0	0	0	0	0	0
Area 12	0	0	0	0	0	0	0	0	0	0	0	0	0	0	0	0	0	0	0	0	0	0	0	0	0
Area 13	0	0	0	0	0	0	0	0	0	0	0	0	0	0	0	0	0	0	0	0	0	0	0	0	0
Area 14	0	0	0	0	0	0	0	0	0	0	0	0	0	0	0	0	0	0	0	0	0	0	0	0	0
Area 15	0	0	0	0	0	0	0	0	0	0	0	0	0	0	0	0	0	0	0	0	0	0	0	0	0
Area 16	0	0	0	0	0	0	0	0	0	0	0	0	0	0	0	0	0	0	0	0	0	0	0	0	0
Area 17	0	0	0	0	0	0	0	0	0	0	0	0	0	0	0	0	0	0	0	0	0	0	0	0	0
Area 18	0	0	0	0	0	0	0	0	0	0	0	0	0	0	0	0	0	0	0	0	0	0	0	0	0
Area 19	0	0	0	0	0	0	0	0	0	0	0	0	0	0	0	0	0	0	0	0	0	0	0	0	0
Area 20	0	0	0	0	0	0	0	0	0	0	0	0	0	0	0	0	0	0	0	0	0	0	0	0	0
Area 21	0	0	0	0	0	0	0	0	0	0	0	0	0	0	0	0	0	0	0	0	0	0	0	0	0
Area 22	0	0	0	0	0	0	0	0	0	0	0	0	0	0	0	0	0	0	0	0	0	0	0	0	0
Area 23	0	0	0	0	0	0	0	0	0	0	0	0	0	0	0	0	0	0	0	0	0	0	0	0	0
Area 24	0	0	0	0	0	0	0	0	0	0	0	0	0	0	0	0	0	0	0	0	0	0	0	0	0

Table S.15 Envelope, Building A, operation based on human behavior (hourly, June 21th, 33years after completion)

	1	2	3	4	5	6	7	8	9	10	11	12	13	14	15	16	17	18	19	20	21	22	23	24
<i>F_{ext}</i>	9.07E-06	8.51E-06	9.07E-06	8.51E-06	4.22E-07	1.57E-07	8.16E-07	1.68E-07	2.54E-07	2.79E-07	3.24E-07	3.43E-07	3.62E-07	3.81E-07	4.00E-07	4.18E-07	4.37E-07	4.55E-07	4.74E-07	4.92E-07	5.11E-07	5.29E-07	5.48E-07	5.66E-07
<i>F_{int}</i>	0	0	0	0	0	0	0	0	0	0	0	0	0	0	0	0	0	0	0	0	0	0	0	0
<i>F_{ext}</i>	0	0	0	0	0	8.28E-05	4.14E-06	9.02E-06	1.38E-07	1.65E-07	1.74E-07	1.69E-07	2.22E-07	2.88E-07	3.45E-07	3.81E-07	3.06E-07	2.13E-07	9.32E-08	1.11E-06	8.14E-08	0	0	0
<i>F_{int}</i>	0	0	0	0	0	0	0	0	0	0	0	0	0	0	0	0	0	0	0	0	0	0	0	0
<i>F_{ext}</i>	0	0	0	0	0	9.80E-05	5.91E-06	1.38E-07	1.94E-07	2.01E-07	2.01E-07	2.37E-07	3.18E-07	3.75E-07	4.87E-07	5.88E-07	6.32E-07	5.41E-07	3.17E-07	3.42E-06	1.01E-06	0	0	0
<i>F_{int}</i>	0	0	0	0	0	0	0	0	0	0	0	0	0	0	0	0	0	0	0	0	0	0	0	0
<i>F_{ext}</i>	0	0	0	0	0	0	3.15E-05	1.79E-05	0	0	0	0	0	0	0	0	0	0	0	0	0	0	0	0
<i>F_{int}</i>	0	0	0	0	0	0	0	0	0	0	0	0	0	0	0	0	0	0	0	0	0	0	0	0
<i>F_{ext}</i>	0	0	0	0	0	0	9.10E-05	5.52E-06	1.29E-07	1.81E-07	1.94E-07	2.52E-07	2.68E-07	2.90E-07	3.20E-07	3.50E-07	3.80E-07	4.10E-07	4.40E-07	4.70E-07	5.00E-07	5.30E-07	5.60E-07	5.90E-07
<i>F_{int}</i>	0	0	0	0	0	0	0	0	0	0	0	0	0	0	0	0	0	0	0	0	0	0	0	0
<i>F_{ext}</i>	5.85E-07	5.85E-07	5.85E-07	5.85E-07	5.85E-10	5.85E-10	8.66E-10	8.66E-10	8.66E-10	8.66E-10	8.66E-10	8.66E-10	8.66E-10	8.66E-10	8.66E-10	8.66E-10	8.66E-10	8.66E-10	8.66E-10	8.66E-10	8.66E-10	8.66E-10	8.66E-10	8.66E-10
<i>F_{int}</i>	0	0	0	0	0	0	0	0	0	0	0	0	0	0	0	0	0	0	0	0	0	0	0	0
<i>F_{ext}</i>	1.00E-10	1.00E-10	1.00E-10	1.00E-10	1.00E-10	1.00E-10	1.00E-10	1.00E-10	1.00E-10	1.00E-10	1.00E-10	1.00E-10	1.00E-10	1.00E-10	1.00E-10	1.00E-10	1.00E-10	1.00E-10	1.00E-10	1.00E-10	1.00E-10	1.00E-10	1.00E-10	1.00E-10
<i>F_{int}</i>	0	0	0	0	0	0	0	0	0	0	0	0	0	0	0	0	0	0	0	0	0	0	0	0
<i>F_{ext}</i>	1.22E-10	1.22E-10	1.22E-10	1.22E-10	1.22E-10	1.22E-10	1.22E-10	1.22E-10	1.22E-10	1.22E-10	1.22E-10	1.22E-10	1.22E-10	1.22E-10	1.22E-10	1.22E-10	1.22E-10	1.22E-10	1.22E-10	1.22E-10	1.22E-10	1.22E-10	1.22E-10	1.22E-10
<i>F_{int}</i>	0	0	0	0	0	0	0	0	0	0	0	0	0	0	0	0	0	0	0	0	0	0	0	0
<i>F_{ext}</i>	1.98E-07	1.98E-07	1.98E-07	1.98E-07	4.92E-09	4.92E-09	4.92E-09	4.92E-09	4.92E-09	4.92E-09	4.92E-09	4.92E-09	4.92E-09	4.92E-09	4.92E-09	4.92E-09	4.92E-09	4.92E-09	4.92E-09	4.92E-09	4.92E-09	4.92E-09	4.92E-09	4.92E-09
<i>F_{int}</i>	0	0	0	0	0	0	0	0	0	0	0	0	0	0	0	0	0	0	0	0	0	0	0	0
<i>F_{ext}</i>	0	0	0	0	0	8.66E-10	8.66E-10	8.66E-10	8.66E-10	8.66E-10	8.66E-10	8.66E-10	8.66E-10	8.66E-10	8.66E-10	8.66E-10	8.66E-10	8.66E-10	8.66E-10	8.66E-10	8.66E-10	8.66E-10	8.66E-10	8.66E-10
<i>F_{int}</i>	0	0	0	0	0	0	0	0	0	0	0	0	0	0	0	0	0	0	0	0	0	0	0	0
<i>F_{ext}</i>	0	0	0	0	0	0	0	0	0	0	0	0	0	0	0	0	0	0	0	0	0	0	0	0
<i>F_{int}</i>	0	0	0	0	0	0	0	0	0	0	0	0	0	0	0	0	0	0	0	0	0	0	0	0
<i>F_{ext}</i>	0	0	0	0	0	0	0	0	0	0	0	0	0	0	0	0	0	0	0	0	0	0	0	0
<i>F_{int}</i>	0	0	0	0	0	0	0	0	0	0	0	0	0	0	0	0	0	0	0	0	0	0	0	0
<i>F_{ext}</i>	4.92E-10	4.92E-10	4.92E-10	4.92E-10	1.36E-11	1.36E-11	1.36E-11	1.36E-11	1.36E-11	1.36E-11	1.36E-11	1.36E-11	1.36E-11	1.36E-11	1.36E-11	1.36E-11	1.36E-11	1.36E-11	1.36E-11	1.36E-11	1.36E-11	1.36E-11	1.36E-11	1.36E-11
<i>F_{int}</i>	0	0	0	0	0	0	0	0	0	0	0	0	0	0	0	0	0	0	0	0	0	0	0	0
<i>F_{ext}</i>	0	0	0	0	0	0	0	0	0	0	0	0	0	0	0	0	0	0	0	0	0	0	0	0
<i>F_{int}</i>	0	0	0	0	0	0	0	0	0	0	0	0	0	0	0	0	0	0	0	0	0	0	0	0
<i>F_{ext}</i>	4.92E-10	4.92E-10	4.92E-10	4.92E-10	1.36E-11	1.36E-11	1.36E-11	1.36E-11	1.36E-11	1.36E-11	1.36E-11	1.36E-11	1.36E-11	1.36E-11	1.36E-11	1.36E-11	1.36E-11	1.36E-11	1.36E-11	1.36E-11	1.36E-11	1.36E-11	1.36E-11	1.36E-11
<i>F_{int}</i>	0	0	0	0	0	0	0	0	0	0	0	0	0	0	0	0	0	0	0	0	0	0	0	0
<i>F_{ext}</i>	0	0	0	0	0	0	0	0	0	0	0	0	0	0	0	0	0	0	0	0	0	0	0	0
<i>F_{int}</i>	0	0	0	0	0	0	0	0	0	0	0	0	0	0	0	0	0	0	0	0	0	0	0	0
<i>F_{ext}</i>	4.92E-10	4.92E-10	4.92E-10	4.92E-10	1.36E-11	1.36E-11	1.36E-11	1.36E-11	1.36E-11	1.36E-11	1.36E-11	1.36E-11	1.36E-11	1.36E-11	1.36E-11	1.36E-11	1.36E-11	1.36E-11	1.36E-11	1.36E-11	1.36E-11	1.36E-11	1.36E-11	1.36E-11
<i>F_{int}</i>	0	0	0	0	0	0	0	0	0	0	0	0	0	0	0	0	0	0	0	0	0	0	0	0
<i>F_{ext}</i>	0	0	0	0	0	0	0	0	0	0	0	0	0	0	0	0	0	0	0	0	0	0	0	0
<i>F_{int}</i>	0	0	0	0	0	0	0	0	0	0	0	0	0	0	0	0	0	0	0	0	0	0	0	0
<i>F_{ext}</i>	4.92E-10	4.92E-10	4.92E-10	4.92E-10	1.36E-11	1.36E-11	1.36E-11	1.36E-11	1.36E-11	1.36E-11	1.36E-11	1.36E-11	1.36E-11	1.36E-11	1.36E-11	1.36E-11	1.36E-11	1.36E-11	1.36E-11	1.36E-11	1.36E-11	1.36E-11	1.36E-11	1.36E-11
<i>F_{int}</i>	0	0	0	0	0	0	0	0	0	0	0	0	0	0	0	0	0	0	0	0	0	0	0	0

Table S.17 Envelope, Building A, passive house insulation + operation based on human behavior (yearly, 50 years)

Year	1	2	3	4	5	6	7	8	9	10	11	12	13	14	15	16	17	18	19	20	21	22	23	24	25			
1	5.73E-12	5.73E-12	5.73E-12	5.73E-12	5.73E-12	5.73E-12	5.73E-12	5.73E-12	5.73E-12	5.73E-12	5.73E-12	5.73E-12	5.73E-12	5.73E-12	5.73E-12	5.73E-12	5.73E-12	5.73E-12	5.73E-12	5.73E-12	5.73E-12	5.73E-12	5.73E-12	5.73E-12	5.73E-12	5.73E-12		
2	5.90E-11	5.90E-11	5.90E-11	5.90E-11	5.90E-11	5.90E-11	5.90E-11	5.90E-11	5.90E-11	5.90E-11	5.90E-11	5.90E-11	5.90E-11	5.90E-11	5.90E-11	5.90E-11	5.90E-11	5.90E-11	5.90E-11	5.90E-11	5.90E-11	5.90E-11	5.90E-11	5.90E-11	5.90E-11	5.90E-11	5.90E-11	
3	8.42E-10	8.42E-10	8.42E-10	8.42E-10	8.42E-10	8.42E-10	8.42E-10	8.42E-10	8.42E-10	8.42E-10	8.42E-10	8.42E-10	8.42E-10	8.42E-10	8.42E-10	8.42E-10	8.42E-10	8.42E-10	8.42E-10	8.42E-10	8.42E-10	8.42E-10	8.42E-10	8.42E-10	8.42E-10	8.42E-10	8.42E-10	8.42E-10
4	7.40E-10	7.40E-10	7.40E-10	7.40E-10	7.40E-10	7.40E-10	7.40E-10	7.40E-10	7.40E-10	7.40E-10	7.40E-10	7.40E-10	7.40E-10	7.40E-10	7.40E-10	7.40E-10	7.40E-10	7.40E-10	7.40E-10	7.40E-10	7.40E-10	7.40E-10	7.40E-10	7.40E-10	7.40E-10	7.40E-10	7.40E-10	7.40E-10
5	5.28E-10	5.28E-10	5.28E-10	5.28E-10	5.28E-10	5.28E-10	5.28E-10	5.28E-10	5.28E-10	5.28E-10	5.28E-10	5.28E-10	5.28E-10	5.28E-10	5.28E-10	5.28E-10	5.28E-10	5.28E-10	5.28E-10	5.28E-10	5.28E-10	5.28E-10	5.28E-10	5.28E-10	5.28E-10	5.28E-10	5.28E-10	5.28E-10
6	3.23E-08	3.23E-08	3.23E-08	3.23E-08	3.23E-08	3.23E-08	3.23E-08	3.23E-08	3.23E-08	3.23E-08	3.23E-08	3.23E-08	3.23E-08	3.23E-08	3.23E-08	3.23E-08	3.23E-08	3.23E-08	3.23E-08	3.23E-08	3.23E-08	3.23E-08	3.23E-08	3.23E-08	3.23E-08	3.23E-08	3.23E-08	3.23E-08
7	0	0	0	0	0	0	0	0	0	0	0	0	0	0	0	0	0	0	0	0	0	0	0	0	0	0	0	0
8	0	0	0	0	0	0	0	0	0	0	0	0	0	0	0	0	0	0	0	0	0	0	0	0	0	0	0	0
9	0	0	0	0	0	0	0	0	0	0	0	0	0	0	0	0	0	0	0	0	0	0	0	0	0	0	0	0
10	0	0	0	0	0	0	0	0	0	0	0	0	0	0	0	0	0	0	0	0	0	0	0	0	0	0	0	0
11	0	0	0	0	0	0	0	0	0	0	0	0	0	0	0	0	0	0	0	0	0	0	0	0	0	0	0	0
12	0	0	0	0	0	0	0	0	0	0	0	0	0	0	0	0	0	0	0	0	0	0	0	0	0	0	0	0
13	0	0	0	0	0	0	0	0	0	0	0	0	0	0	0	0	0	0	0	0	0	0	0	0	0	0	0	0
14	0	0	0	0	0	0	0	0	0	0	0	0	0	0	0	0	0	0	0	0	0	0	0	0	0	0	0	0
15	0	0	0	0	0	0	0	0	0	0	0	0	0	0	0	0	0	0	0	0	0	0	0	0	0	0	0	0
16	0	0	0	0	0	0	0	0	0	0	0	0	0	0	0	0	0	0	0	0	0	0	0	0	0	0	0	0
17	0	0	0	0	0	0	0	0	0	0	0	0	0	0	0	0	0	0	0	0	0	0	0	0	0	0	0	0
18	0	0	0	0	0	0	0	0	0	0	0	0	0	0	0	0	0	0	0	0	0	0	0	0	0	0	0	0
19	0	0	0	0	0	0	0	0	0	0	0	0	0	0	0	0	0	0	0	0	0	0	0	0	0	0	0	0
20	0	0	0	0	0	0	0	0	0	0	0	0	0	0	0	0	0	0	0	0	0	0	0	0	0	0	0	0
21	0	0	0	0	0	0	0	0	0	0	0	0	0	0	0	0	0	0	0	0	0	0	0	0	0	0	0	0
22	0	0	0	0	0	0	0	0	0	0	0	0	0	0	0	0	0	0	0	0	0	0	0	0	0	0	0	0
23	0	0	0	0	0	0	0	0	0	0	0	0	0	0	0	0	0	0	0	0	0	0	0	0	0	0	0	0
24	0	0	0	0	0	0	0	0	0	0	0	0	0	0	0	0	0	0	0	0	0	0	0	0	0	0	0	0
25	0	0	0	0	0	0	0	0	0	0	0	0	0	0	0	0	0	0	0	0	0	0	0	0	0	0	0	0

Table S.18 Envelope, Building A, passive house insulation + operation based on human behavior (monthly, 33 years after completion)

	1	2	3	4	5	6	7	8	9	10	11	12	13	14	15	16	17	18	19	20	21	22	23	24		
<i>Fuss</i>	6.0E+10	7.1E+10	8.2E+10	1.0E+11	1.2E+11	1.4E+11	1.6E+11	1.8E+11	2.0E+11	2.2E+11	2.4E+11	2.6E+11	2.8E+11	3.0E+11	3.2E+11	3.4E+11	3.6E+11	3.8E+11	4.0E+11	4.2E+11	4.4E+11	4.6E+11	4.8E+11	5.0E+11		
<i>Fuss</i>	0	0	0	0	0	0	0	0	0	0	0	0	0	0	0	0	0	0	0	0	0	0	0	0		
<i>Fuss</i>	1.8E+09	1.4E+09	1.9E+09	2.3E+09	2.1E+09	1.8E+09	2.4E+09	2.5E+09	1.5E+09	2.2E+09	2.3E+09	2.0E+09	1.9E+09	1.8E+09	2.7E+09	2.1E+09	1.5E+09	1.1E+09	1.4E+09	1.4E+09	1.4E+09	1.4E+09	1.5E+09	1.3E+09	1.3E+09	
<i>Fuss</i>	0	0	0	0	0	0	0	0	0	0	0	0	0	0	0	0	0	0	0	0	0	0	0	0		
<i>Fuss</i>	1.3E+08	4.9E+08	1.7E+08	1.8E+08	6.9E+08	7.0E+08	8.9E+08	9.6E+08	9.2E+08	1.1E+09	1.1E+09	1.2E+09	1.2E+09	1.3E+09	1.4E+09	1.4E+09	1.5E+09	1.6E+09	1.7E+09	1.7E+09	1.7E+09	1.7E+09	1.7E+09	1.7E+09	1.7E+09	
<i>Fuss</i>	0	0	0	0	0	0	0	0	0	0	0	0	0	0	0	0	0	0	0	0	0	0	0	0		
<i>Fuss</i>	6.1E+07	5.3E+07	9.8E+07	9.8E+07	1.0E+08	1.0E+08	1.5E+08	1.8E+08	1.2E+08	2.2E+08	2.3E+08	2.0E+08	2.0E+08	3.7E+08	3.0E+08	2.2E+08	1.6E+08	1.1E+08	1.4E+08	1.4E+08	1.4E+08	1.4E+08	1.5E+08	1.3E+08	1.3E+08	
<i>Fuss</i>	0	0	0	0	0	0	0	0	0	0	0	0	0	0	0	0	0	0	0	0	0	0	0	0		
<i>Fuss</i>	5.6E+08	4.4E+08	5.7E+08	7.2E+08	6.7E+08	5.7E+08	7.6E+08	7.8E+08	4.0E+08	6.9E+08	6.2E+08	6.8E+08	5.8E+08	5.9E+08	8.5E+08	6.5E+08	4.2E+08	6.2E+08	6.2E+08	6.2E+08	6.2E+08	6.2E+08	6.2E+08	6.2E+08	6.2E+08	
<i>Fuss</i>	1.0E+08	1.4E+08	1.8E+08	2.8E+08	1.8E+08	1.8E+08	2.8E+08	2.8E+08	1.8E+08	3.1E+08	3.0E+08	2.9E+08	2.9E+08	3.0E+08	3.2E+08	3.2E+08	3.2E+08	3.2E+08	3.2E+08	3.2E+08	3.2E+08	3.2E+08	3.2E+08	3.2E+08	3.2E+08	
<i>Fuss</i>	2.8E+06	2.4E+06	7.2E+06	7.2E+06	9.6E+06	9.6E+06	9.6E+06	9.6E+06	9.6E+06	9.6E+06	9.6E+06	9.6E+06	9.6E+06	9.6E+06	9.6E+06	9.6E+06	9.6E+06	9.6E+06	9.6E+06	9.6E+06	9.6E+06	9.6E+06	9.6E+06	9.6E+06	9.6E+06	
<i>Fuss</i>	1.4E+13	1.4E+13	1.4E+13	1.4E+13	1.4E+13	1.4E+13	1.4E+13	1.4E+13	1.4E+13	1.4E+13	1.4E+13	1.4E+13	1.4E+13	1.4E+13	1.4E+13	1.4E+13	1.4E+13	1.4E+13	1.4E+13	1.4E+13	1.4E+13	1.4E+13	1.4E+13	1.4E+13	1.4E+13	
<i>Fuss</i>	3.8E+12	3.2E+12	3.8E+12	3.8E+12	3.8E+12	3.8E+12	3.8E+12	3.8E+12	3.8E+12	3.8E+12	3.8E+12	3.8E+12	3.8E+12	3.8E+12	3.8E+12	3.8E+12	3.8E+12	3.8E+12	3.8E+12	3.8E+12	3.8E+12	3.8E+12	3.8E+12	3.8E+12	3.8E+12	
<i>Fuss</i>	3.2E+13	3.2E+13	3.2E+13	3.2E+13	3.2E+13	3.2E+13	3.2E+13	3.2E+13	3.2E+13	3.2E+13	3.2E+13	3.2E+13	3.2E+13	3.2E+13	3.2E+13	3.2E+13	3.2E+13	3.2E+13	3.2E+13	3.2E+13	3.2E+13	3.2E+13	3.2E+13	3.2E+13	3.2E+13	
<i>Fuss</i>	2.1E+13	2.1E+13	2.1E+13	2.1E+13	2.1E+13	2.1E+13	2.1E+13	2.1E+13	2.1E+13	2.1E+13	2.1E+13	2.1E+13	2.1E+13	2.1E+13	2.1E+13	2.1E+13	2.1E+13	2.1E+13	2.1E+13	2.1E+13	2.1E+13	2.1E+13	2.1E+13	2.1E+13	2.1E+13	
<i>Fuss</i>	1.8E+12	2.8E+12	3.8E+12	2.8E+12	2.8E+12	2.8E+12	2.8E+12	2.8E+12	2.8E+12	2.8E+12	2.8E+12	2.8E+12	2.8E+12	2.8E+12	2.8E+12	2.8E+12	2.8E+12	2.8E+12	2.8E+12	2.8E+12	2.8E+12	2.8E+12	2.8E+12	2.8E+12	2.8E+12	
<i>Fuss</i>	2.9E+12	3.9E+12	3.9E+12	3.9E+12	3.9E+12	3.9E+12	3.9E+12	3.9E+12	3.9E+12	3.9E+12	3.9E+12	3.9E+12	3.9E+12	3.9E+12	3.9E+12	3.9E+12	3.9E+12	3.9E+12	3.9E+12	3.9E+12	3.9E+12	3.9E+12	3.9E+12	3.9E+12	3.9E+12	
<i>Fuss</i>	3.2E+12	4.8E+12	6.2E+12	4.8E+12	4.8E+12	4.8E+12	4.8E+12	4.8E+12	4.8E+12	4.8E+12	4.8E+12	4.8E+12	4.8E+12	4.8E+12	4.8E+12	4.8E+12	4.8E+12	4.8E+12	4.8E+12	4.8E+12	4.8E+12	4.8E+12	4.8E+12	4.8E+12	4.8E+12	
<i>Fuss</i>	1.8E+13	2.9E+13	4.0E+13	2.9E+13	2.9E+13	2.9E+13	2.9E+13	2.9E+13	2.9E+13	2.9E+13	2.9E+13	2.9E+13	2.9E+13	2.9E+13	2.9E+13	2.9E+13	2.9E+13	2.9E+13	2.9E+13	2.9E+13	2.9E+13	2.9E+13	2.9E+13	2.9E+13	2.9E+13	
<i>Fuss</i>	2.1E+13	2.9E+13	4.0E+13	2.9E+13	2.9E+13	2.9E+13	2.9E+13	2.9E+13	2.9E+13	2.9E+13	2.9E+13	2.9E+13	2.9E+13	2.9E+13	2.9E+13	2.9E+13	2.9E+13	2.9E+13	2.9E+13	2.9E+13	2.9E+13	2.9E+13	2.9E+13	2.9E+13	2.9E+13	
<i>Fuss</i>	2.3E+12	2.8E+12	3.8E+12	2.8E+12	2.8E+12	2.8E+12	2.8E+12	2.8E+12	2.8E+12	2.8E+12	2.8E+12	2.8E+12	2.8E+12	2.8E+12	2.8E+12	2.8E+12	2.8E+12	2.8E+12	2.8E+12	2.8E+12	2.8E+12	2.8E+12	2.8E+12	2.8E+12	2.8E+12	
<i>Fuss</i>	1.3E+13	1.4E+13	1.8E+13	1.4E+13	1.4E+13	1.4E+13	1.4E+13	1.4E+13	1.4E+13	1.4E+13	1.4E+13	1.4E+13	1.4E+13	1.4E+13	1.4E+13	1.4E+13	1.4E+13	1.4E+13	1.4E+13	1.4E+13	1.4E+13	1.4E+13	1.4E+13	1.4E+13	1.4E+13	
<i>Fuss</i>	3.0E+12	4.3E+12	5.7E+12	4.3E+12	4.3E+12	4.3E+12	4.3E+12	4.3E+12	4.3E+12	4.3E+12	4.3E+12	4.3E+12	4.3E+12	4.3E+12	4.3E+12	4.3E+12	4.3E+12	4.3E+12	4.3E+12	4.3E+12	4.3E+12	4.3E+12	4.3E+12	4.3E+12	4.3E+12	
<i>Fuss</i>	1.3E+13	1.4E+13	1.8E+13	1.4E+13	1.4E+13	1.4E+13	1.4E+13	1.4E+13	1.4E+13	1.4E+13	1.4E+13	1.4E+13	1.4E+13	1.4E+13	1.4E+13	1.4E+13	1.4E+13	1.4E+13	1.4E+13	1.4E+13	1.4E+13	1.4E+13	1.4E+13	1.4E+13	1.4E+13	
<i>Fuss</i>	0	0	0	0	0	0	0	0	0	0	0	0	0	0	0	0	0	0	0	0	0	0	0	0	0	
<i>Fuss</i>	2.8E+10	2.2E+09	3.3E+09	3.1E+09	2.3E+09	1.6E+05	7.7E+09	3.7E+08	3.8E+13	3.7E+13	2.2E+13	3.2E+13	2.3E+13	2.3E+13	3.4E+13	3.0E+13	3.0E+13	3.0E+13	3.0E+13	3.0E+13	3.0E+13	3.0E+13	3.0E+13	3.0E+13	3.0E+13	3.0E+13

Table S.18 CONT.

35	36	37	38	39	40	41	42	43	44	45	46	47	48									
1.00E+10	1.11E+11	1.03E+11	9.54E+10	1.04E+11	1.03E+11	1.44E+11	9.33E+10	1.43E+11	1.20E+11	1.20E+11	9.66E+10	1.33E+11	9.33E+10									
1.00E+10	1.11E+11	1.03E+11	1.52E+10	1.23E+10	1.03E+11	1.15E+10	9.33E+10	9.78E+09	1.43E+11	1.40E+10	1.61E+10	1.35E+10	1.43E+11									
0	0	0	0	0	0	0	0	0	0	0	0	0	0									
1.24E+09	1.08E+09	2.14E+09	1.97E+09	1.65E+09	1.46E+09	1.29E+09	1.69E+09	1.44E+09	1.61E+09	2.27E+09	1.61E+09	1.35E+09	1.35E+09									
1.21E+09	1.13E+09	1.37E+09	1.85E+09	1.33E+09	1.43E+09	1.58E+09	1.36E+09	1.36E+09	1.36E+09	1.36E+09	1.36E+09	1.36E+09	1.36E+09									
1.24E+09	1.22E+09	1.32E+09	1.30E+09	1.20E+09	1.28E+09	1.24E+09	1.20E+09	1.28E+09	1.36E+09	1.24E+09	1.24E+09	1.20E+09	1.20E+09									
2.34E+08	2.21E+08	4.25E+08	4.49E+08	3.79E+08	2.71E+08	2.85E+08	2.38E+08	1.88E+08	1.88E+08	3.57E+08	1.65E+08	1.38E+08	1.38E+08									
0	0	0	0	0	0	0	0	0	0	0	0	0	0									
4.33E+08	3.95E+08	7.99E+08	7.89E+08	2.99E+08	5.07E+08	4.90E+08	6.38E+08	5.76E+08	5.68E+08	5.82E+08	1.12E+09	6.48E+08	8.32E+08									
1.90E+08	2.90E+08	3.00E+08	3.91E+08	2.90E+08	2.99E+08	2.99E+08	2.99E+08	2.99E+08	2.99E+08	3.67E+08	2.34E+08	3.42E+08	3.42E+08									
6.98E+07	7.71E+07	1.02E+08	1.46E+08	2.12E+08	6.52E+07	8.52E+07	7.79E+07	6.04E+07	4.72E+07	4.72E+07	7.71E+07	2.23E+07	2.23E+07									
1.42E+13	1.42E+13	1.42E+13	1.42E+13	1.42E+13	1.42E+13	1.42E+13	1.42E+13	1.42E+13	1.42E+13	1.42E+13	1.42E+13	1.42E+13	1.42E+13									
3.80E+12	3.80E+12	3.80E+12	3.80E+12	3.80E+12	3.80E+12	3.80E+12	3.80E+12	3.80E+12	3.80E+12	3.80E+12	3.80E+12	3.80E+12	3.80E+12									
3.23E+13	3.23E+13	3.23E+13	3.23E+13	3.23E+13	3.23E+13	3.23E+13	3.23E+13	3.23E+13	3.23E+13	3.23E+13	3.23E+13	3.23E+13	3.23E+13									
1.61E+13	1.61E+13	1.61E+13	1.61E+13	1.61E+13	1.61E+13	1.61E+13	1.61E+13	1.61E+13	1.61E+13	1.61E+13	1.61E+13	1.61E+13	1.61E+13									
2.12E+13	2.12E+13	2.12E+13	2.12E+13	2.12E+13	2.12E+13	2.12E+13	2.12E+13	2.12E+13	2.12E+13	2.12E+13	2.12E+13	2.12E+13	2.12E+13									
1.32E+13	1.32E+13	1.32E+13	1.32E+13	1.32E+13	1.32E+13	1.32E+13	1.32E+13	1.32E+13	1.32E+13	1.32E+13	1.32E+13	1.32E+13	1.32E+13									
1.89E+14	1.89E+14	1.89E+14	1.89E+14	1.89E+14	1.89E+14	1.89E+14	1.89E+14	1.89E+14	1.89E+14	1.89E+14	1.89E+14	1.89E+14	1.89E+14									
4.79E+11	5.08E+11	5.18E+11	5.29E+11	5.38E+11	5.40E+11	5.49E+11	4.87E+11	4.88E+11	4.57E+11	4.56E+11	4.09E+11	4.08E+11	4.09E+11									
2.48E+11	2.66E+11	2.65E+11	2.74E+11	2.78E+11	2.83E+11	2.92E+11	2.32E+11	2.33E+11	2.33E+11	2.14E+11	2.01E+11	1.85E+11	1.85E+11									
1.80E+11	1.92E+11	1.98E+11	2.04E+11	2.03E+11	1.78E+11	1.89E+11	1.99E+11	1.99E+11	1.99E+11	1.99E+11	1.99E+11	1.99E+11	1.99E+11									
9.57E+07	8.74E+07	8.74E+07	7.49E+08	7.15E+08	1.03E+08	6.53E+08	6.32E+08	1.05E+08	8.68E+07	8.68E+07	1.55E+08	6.80E+07	6.42E+07									
2.10E+08	1.74E+08	3.09E+08	3.05E+08	2.44E+08	2.11E+08	2.04E+08	2.28E+08	1.91E+08	1.91E+08	3.87E+08	1.79E+08	2.06E+08	1.60E+08									
4.40E+08	3.79E+08	7.15E+08	6.74E+08	5.84E+08	5.11E+08	4.56E+08	5.97E+08	5.12E+08	8.17E+08	5.82E+08	5.82E+08	1.22E+09	6.99E+08									
2.01E+08	1.95E+08	2.64E+08	3.01E+08	2.22E+08	2.21E+08	2.28E+08	2.59E+08	2.76E+08	3.51E+08	2.31E+08	2.31E+08	2.31E+08	2.31E+08									
9.57E+07	8.53E+07	1.72E+08	1.50E+08	1.18E+08	1.03E+08	8.97E+07	9.69E+07	1.05E+08	1.05E+08	8.68E+07	8.68E+07	1.55E+08	6.87E+07									
2.18E+13	2.08E+13	2.18E+13	2.20E+13	2.11E+13	1.54E+13	2.20E+13	2.27E+13	2.27E+13	2.27E+13	2.27E+13	2.27E+13	2.27E+13	2.27E+13									
1.28E+13	1.28E+13	1.28E+13	1.28E+13	1.28E+13	1.28E+13	1.28E+13	1.28E+13	1.28E+13	1.28E+13	1.28E+13	1.28E+13	1.28E+13	1.28E+13									
0	0	0	0	0	0	0	0	0	0	0	0	0	0									
1.56E+13	3.08E+12	1.67E+12	4.28E+11	3.72E+11	1.42E+11	1.50E+12	3.77E+13	3.15E+13	3.15E+13	3.15E+13	3.15E+13	3.15E+13	3.15E+13									
1.28E+12	0	0	0	0	1.62E+10	0	0	0	0	0	0	0	0									
1.79E+12	0	0	0	0	2.41E+10	0	0	0	0	0	0	0	0									
2.10E+12	0	0	0	0	2.83E+10	0	0	0	0	0	0	0	0									
9.40E+09	7.53E+09	5.79E+09	4.03E+09	1.43E+11	1.50E+10	1.20E+10	1.99E+10	1.99E+10	4.84E+10	2.81E+10	7.62E+10	2.61E+10	2.61E+10									
1.58E+10	3.08E+12	2.97E+10	4.31E+10	3.77E+11	8.72E+10	3.44E+10	5.52E+10	5.50E+10	6.96E+10	1.08E+12	1.08E+12	2.21E+12	9.47E+11									
1.27E+12	3.37E+10	1.28E+12	1.28E+10	3.77E+09	3.77E+09	3.77E+09	3.77E+09	3.77E+09	3.77E+09	3.77E+09	3.77E+09	3.77E+09	3.77E+09									
1.81E+12	8.93E+09	9.72E+09	4.56E+09	1.80E+09	4.82E+10	1.37E+10	1.37E+10	4.16E+12	2.43E+12	1.48E+12	1.48E+12	1.48E+12	1.48E+12									
1.58E+14	8.56E+12	2.42E+14	8.77E+12	2.89E+14	3.17E+14	2.79E+14	8.73E+14	1.04E+14	1.04E+14	9.31E+14	9.02E+14	1.21E+14	1.21E+14									
7.25E+11	1.13E+12	8.53E+11	3.52E+11	3.68E+11	1.98E+11	7.65E+11	9.17E+11	1.50E+14	1.48E+12	1.66E+14	1.66E+14	2.11E+12	1.80E+14									
0	0	0	0	0	0	0	0	0	0	0	0	0	0									
0	0	0	0	0	0	0	0	0	0	0	0	0	0									
1.08E+13	3.30E+13	3.57E+13	3.63E+13	3.58E+13	2.95E+13	3.69E+13	0	0	0	0	1.57E+13	2.20E+12	3.76E+13	3.91E+13	3.92E+13	3.84E+13	3.98E+13	3.98E+13	3.84E+13	4.00E+13	1.46E+09	4.05E+09

Table S.19 Envelope, Building A, passive house insulation + operation based on human behavior (hourly, June 21th, 33 years after completion)

Day	1	2	3	4	5	6	7	8	9	10	11	12	13	14	15	16	17	18	19	20	21	22	23	24
1	0	8.51E+06	9.07E+06	8.51E+06	0	0	0	0	0	0	0	0	0	0	0	0	0	0	0	0	0	0	0	0
2	0	0	0	0	0	0	0	0	0	0	0	0	0	0	0	0	0	0	0	0	0	0	0	0
3	0	0	0	0	0	0	0	0	0	0	0	0	0	0	0	0	0	0	0	0	0	0	0	0
4	0	0	0	0	0	0	0	0	0	0	0	0	0	0	0	0	0	0	0	0	0	0	0	0
5	0	0	0	0	0	0	0	0	0	0	0	0	0	0	0	0	0	0	0	0	0	0	0	0
6	0	0	0	0	0	0	0	0	0	0	0	0	0	0	0	0	0	0	0	0	0	0	0	0
7	0	0	0	0	0	0	0	0	0	0	0	0	0	0	0	0	0	0	0	0	0	0	0	0
8	0	0	0	0	0	0	0	0	0	0	0	0	0	0	0	0	0	0	0	0	0	0	0	0
9	0	0	0	0	0	0	0	0	0	0	0	0	0	0	0	0	0	0	0	0	0	0	0	0
10	0	0	0	0	0	0	0	0	0	0	0	0	0	0	0	0	0	0	0	0	0	0	0	0
11	0	0	0	0	0	0	0	0	0	0	0	0	0	0	0	0	0	0	0	0	0	0	0	0
12	0	0	0	0	0	0	0	0	0	0	0	0	0	0	0	0	0	0	0	0	0	0	0	0
13	0	0	0	0	0	0	0	0	0	0	0	0	0	0	0	0	0	0	0	0	0	0	0	0
14	0	0	0	0	0	0	0	0	0	0	0	0	0	0	0	0	0	0	0	0	0	0	0	0
15	0	0	0	0	0	0	0	0	0	0	0	0	0	0	0	0	0	0	0	0	0	0	0	0
16	0	0	0	0	0	0	0	0	0	0	0	0	0	0	0	0	0	0	0	0	0	0	0	0
17	0	0	0	0	0	0	0	0	0	0	0	0	0	0	0	0	0	0	0	0	0	0	0	0
18	0	0	0	0	0	0	0	0	0	0	0	0	0	0	0	0	0	0	0	0	0	0	0	0
19	0	0	0	0	0	0	0	0	0	0	0	0	0	0	0	0	0	0	0	0	0	0	0	0
20	0	0	0	0	0	0	0	0	0	0	0	0	0	0	0	0	0	0	0	0	0	0	0	0
21	0	0	0	0	0	0	0	0	0	0	0	0	0	0	0	0	0	0	0	0	0	0	0	0
22	0	0	0	0	0	0	0	0	0	0	0	0	0	0	0	0	0	0	0	0	0	0	0	0
23	0	0	0	0	0	0	0	0	0	0	0	0	0	0	0	0	0	0	0	0	0	0	0	0
24	0	0	0	0	0	0	0	0	0	0	0	0	0	0	0	0	0	0	0	0	0	0	0	0

Table S.20 Envelope, Building A, passive house insulation + operation based on human behavior (hourly, December 21th, 33 years after completion)

	1	2	3	4	5	6	7	8	9	10	11	12	13	14	15	16	17	18	19	20	21	22	23	24
<i>J_{a,t}</i>	5.10E+06	5.07E+06	5.10E+06	5.07E+06	5.10E+06	5.07E+06	5.10E+06	5.07E+06	5.10E+06	5.07E+06	5.10E+06	5.07E+06	5.10E+06	5.07E+06	5.10E+06	5.07E+06	5.10E+06	5.07E+06	5.10E+06	5.07E+06	5.10E+06	5.07E+06	5.10E+06	5.07E+06
<i>J_{s,t}</i>	0	0	0	0	0	0	0	0	0	0	0	0	0	0	0	0	0	0	0	0	0	0	0	0
<i>J_{r,t}</i>	8.99E+10	8.99E+10	8.99E+10	8.99E+10	8.99E+10	8.99E+10	8.99E+10	8.99E+10	8.99E+10	8.99E+10	8.99E+10	8.99E+10	8.99E+10	8.99E+10	8.99E+10	8.99E+10	8.99E+10	8.99E+10	8.99E+10	8.99E+10	8.99E+10	8.99E+10	8.99E+10	8.99E+10
<i>J_{i,t}</i>	0	0	0	0	0	0	0	0	0	0	0	0	0	0	0	0	0	0	0	0	0	0	0	0
<i>J_{o,t}</i>	0	0	0	0	0	0	0	0	0	0	0	0	0	0	0	0	0	0	0	0	0	0	0	0
<i>J_{a,t}</i>	0	0	0	0	0	0	0	0	0	0	0	0	0	0	0	0	0	0	0	0	0	0	0	0
<i>J_{s,t}</i>	0	0	0	0	0	0	0	0	0	0	0	0	0	0	0	0	0	0	0	0	0	0	0	0
<i>J_{r,t}</i>	0	0	0	0	0	0	0	0	0	0	0	0	0	0	0	0	0	0	0	0	0	0	0	0
<i>J_{i,t}</i>	0	0	0	0	0	0	0	0	0	0	0	0	0	0	0	0	0	0	0	0	0	0	0	0
<i>J_{o,t}</i>	0	0	0	0	0	0	0	0	0	0	0	0	0	0	0	0	0	0	0	0	0	0	0	0
<i>J_{a,t}</i>	0	0	0	0	0	0	0	0	0	0	0	0	0	0	0	0	0	0	0	0	0	0	0	0
<i>J_{s,t}</i>	0	0	0	0	0	0	0	0	0	0	0	0	0	0	0	0	0	0	0	0	0	0	0	0
<i>J_{r,t}</i>	0	0	0	0	0	0	0	0	0	0	0	0	0	0	0	0	0	0	0	0	0	0	0	0
<i>J_{i,t}</i>	0	0	0	0	0	0	0	0	0	0	0	0	0	0	0	0	0	0	0	0	0	0	0	0
<i>J_{o,t}</i>	0	0	0	0	0	0	0	0	0	0	0	0	0	0	0	0	0	0	0	0	0	0	0	0
<i>J_{a,t}</i>	0	0	0	0	0	0	0	0	0	0	0	0	0	0	0	0	0	0	0	0	0	0	0	0
<i>J_{s,t}</i>	0	0	0	0	0	0	0	0	0	0	0	0	0	0	0	0	0	0	0	0	0	0	0	0
<i>J_{r,t}</i>	0	0	0	0	0	0	0	0	0	0	0	0	0	0	0	0	0	0	0	0	0	0	0	0
<i>J_{i,t}</i>	0	0	0	0	0	0	0	0	0	0	0	0	0	0	0	0	0	0	0	0	0	0	0	0
<i>J_{o,t}</i>	0	0	0	0	0	0	0	0	0	0	0	0	0	0	0	0	0	0	0	0	0	0	0	0
<i>J_{a,t}</i>	0	0	0	0	0	0	0	0	0	0	0	0	0	0	0	0	0	0	0	0	0	0	0	0
<i>J_{s,t}</i>	0	0	0	0	0	0	0	0	0	0	0	0	0	0	0	0	0	0	0	0	0	0	0	0
<i>J_{r,t}</i>	0	0	0	0	0	0	0	0	0	0	0	0	0	0	0	0	0	0	0	0	0	0	0	0
<i>J_{i,t}</i>	0	0	0	0	0	0	0	0	0	0	0	0	0	0	0	0	0	0	0	0	0	0	0	0
<i>J_{o,t}</i>	0	0	0	0	0	0	0	0	0	0	0	0	0	0	0	0	0	0	0	0	0	0	0	0

Bibliography

- [1] Abel, T. "The 'Locations' of Households within the Culture-Nature Hierarchy of Hualien County, Taiwan." Paper presented at the the 6th Emergy Conference, Gainesville, Florida, 2010.
- [2] Adalberth, K. "Energy Use During the Life Cycle of Buildings: A Method." *Building and Environment* 32, no. 4 (1997): 317-20.
- [3] Allen, T. F. H., and Thomas B. Starr. *Hierarchy : Perspectives for Ecological Complexity*. Chicago: University of Chicago Press, 1982.
- [4] Andersen, S., J. Dinesen, H. Hjort Knudsen, and A. Willendrup. "Livscyklus-Baseret Bygningsprojektering." In *Report no 224*. Hershholm, Denmark: Danish Building Research Institute, 1993.
- [5] Anderson, J. "On General System Theory and the Concept of Entropy in Urban Geography." In *Research Paper*. London, UK: London School of Economics, Graduate Geography Department, 1969.
- [6] Aoki, I. "Entropy Laws in Ecological Networks at Steady State." *Ecological Modelling* 42 (1988): 289-303.
- [7] ASHRAE. *Energy Standard for Buildings except Low-Rise Residential Buildings*. Atlanta, GA: Thomson Reuters LLC., 2013.
- [8] Ayeni, M.A.O. "The City System and the Use of Entropy in Urban Analysis." *Urban Ecology* 2 (1976): 33-53.
- [9] Ayres, R.U. "Ecology Vs. Economics: Confusing Production and Consumption." Fontainebleau, France: Center of the Management of Environmental Resources, INSEAD, 1998.
- [10] Bailey, K.D. "Social Entropy Theory: An Overview." *Systems Practices* 3, no. 4 (1990): 365-82.
- [11] Baral, A., and B.R. Bakshi. "Emergy Analysis Using Us Economic Input–Output Models with Applications to Life Cycles of Gasoline and Corn Ethanol." *Ecological Modelling* 221 (2010): 1807-18.
- [12] Bastianoni, S., D.E. Campbell, R. Ridolfi, and F.M. Pulselli. "The Solar Transformity of Petroleum Fuels, Ecological Modeling." *Ecological Modelling* 220 (2009): 40-50.
- [13] Bastianoni, S., A. Facchini, L. Susani, and E. Tiezzi. "Emergy as a Function of Exergy." *Energy* 32 (2007): 1158-62.

- [14] Batty, M. "Spatial Entropy." *Geographical Analysis* 6 (1974): 1-31.
- [15] Becker, Rachel, Gustavo Haquin, and Konstantin Kovler. "Air Change Rates and Radon Accumulation in Rooms with Various Levels of Window and Door Closure." *Journal of Building Physics* 38, no. 3 (2014): 234-61.
- [16] Bekker, P.C.F. "A Life-Cycle Approach in Building." *Building and Environment* 17, no. 1 (1982): 55-61.
- [17] Berry, B.J.L. "Cities as Systems within Systems of Cities." *Papers in Regional Science* 13, no. 1 (1964): 147-63.
- [18] Bjørn, A., and M. Strandesen. "The Cradle to Cradle Concept - Is It Always Sustainable?" In *LCM 2011*. The dahlem cube, Berlin, 2011.
- [19] Boltzmann, L. "The Second Law of Thermodynamics." In *Theoretical Physics and Philosophical Problems: Selected Writings*, edited by B.F. McGuinness. Dordrecht, Holland: D. Reider Publishing Company, 1886.
- [20] Bond, T.E.T. "Applicability of the Logarithmic Series to the Distribution of the British Hieracia and Other Plants." *Proc. Linnean Soc. London* (1952): 29-38.
- [21] Bossel, H. "Assessing Viability and Sustainability: A Systems-Based Approach for Deriving Comprehensive Indicator Sets." *Conservation Ecology* 5, no. 12 (2001).
- [22] Braham, W.W. "Architecture, Style, and Power: The Work of Civilization." In *Architecture and Energy Performance and Style*, edited by W.W. Braham and D. Willis, 9-24. New York: Routledge, 2013.
- [23] ———. "Environmental Building Design: Forms of Emergy." *Proceedings from the 7th Biennial Emergy Analysis Research Conference, Gainesville, FL* (2012): 141-46.
- [24] Braham, W.W., and H. Yi. "Hierarchies of Production in a Contemporary Residence." *Proceedings of 8th Emergy Conference* (2014).
- [25] Brillouin, L. "Life, Thermodynamics, and Cybernetics." *American Scientist* 37, no. 4 (1949): 554-68.
- [26] ———. "Thermodynamics, Statistics, and Information." *American Journal of Physics* 29 (1961): 318-28.
- [27] Brockett, P.L., A. Charnes, W.W. Cooper, D. Learner, and F.Y. Phillips. "Information Theory as a Unifying Statistical Approach for Use in Marketing

- Research." *European Journal of Operational Research* 84 (1995): 310-29.
- [28] Brown, M.T. "Areal Empower Density, Unit Emergy Values, and Emformation." In *the Third Biennial Emergy Conference*, 1-16. Gainesville, FL, 2005.
- [29] Brown, M.T., and V. Buranakarn. "Emergy Indices and Ratios for Sustainable Material Cycles and Recycle Options." *Resources, Conservation and Recycling* 38, no. 1 (2003): 1-22.
- [30] Brown, M.T., and M.J. Cohen. "Emergy and Network Analysis." In *Encyclopedia of Ecology*, 1229-39, 2008.
- [31] Brown, M.T., and R.A. Herendeen. "Embodied Energy Analysis and Emergy Analysis: A Comparative View." *Ecological Economics* 19 (1996): 219-35.
- [32] Brown, M.T., H.T. Odum, and S.E. Jørgensen. "Energy Hierarchy and Transformity in the Universe." *Ecological Modelling* 178 (2004): 17-28.
- [33] Brown, M.T., M. Raugei, and S. Ulgiati. "On Boundaries and 'Investments' in Emergy Synthesis and Lca: A Case Study on Thermal Vs. Photovoltaic Electricity." *Ecological Indicators* 15 (2012): 227-35.
- [34] Brown, M.T., and S. Ulgiati. "Updated Evaluation of Exergy and Emergy Driving the Geobiosphere: A Review and Refinement of the Emergy Baseline." *Ecological Modelling* 221 (2010): 2501-08.
- [35] Buenfil, A.A. "Emergy Evaluation of Water." Ph.D. dissertation, University of Florida, 2001.
- [36] Bullard, C.W., P.S. Penner, and D.A. Pilati. "Net Energy Analysis." *Resources and Energy* 1 (1978): 267-313.
- [37] Buranakarn, V. "Evaluation of Recycling and Reuse of Building Materials Using the Emergy Analysis Method." Ph.D. dissertation, University of Florida, 1998.
- [38] Cabeza, L.F., L. Rincon, V. Vilarino, G. Perez, and A. Castell. "Life Cycle Assessment (Lca) and Life Cycle Energy Analysis (Lcea) of Buildings and the Building Sector: A Review." *Renewable and Sustainable Energy Reviews* 29, no. 394-416 (2014).
- [39] Cabezas, H., D. Campbell, T. Eason, A.S. Garmestani, M.T. Herberling, M.E. Hopton, J. Templeton, and M. Zanowick. "San Luis Basin Sustainability Metrics Project: A Methodology for Evaluating Regional Sustainability." edited by M.T. Heberling and M.E. Hopton, 119-36: United States Environmental Protection Agency (US EPA), 2010.
- [40] Cabezas, H., and A.T. Karunanithi. "Fisher Information, Entropy, and the Second

- and Third Laws of Thermodynamics." *Industrial & Engineering Chemistry Research* 47 (2008): 5243-49.
- [41] Cabezas, H., C.W. Pawlowski, A.L. Mayer, and N.T. Hoagland. "Sustainability: Ecological, Social, Economic, Technological, and Systems Perspectives." *Clean Technologies and Environmental Policy* 5 (2003): 167-80.
- [42] ———. "Sustainable Systems Theory: Ecological and Other Aspects." *Journal of Cleaner Production* 13 (2005): 455-67.
- [43] Cai, T.T., T.W. Olsen, and D.E. Campbell. "Maximum (Em)Power: A Foundational Principle Linking Man and Nature." *Ecological Modelling* 178 (2004): 115-19.
- [44] Cale, William G. Jr., and Patrick L. Odell. "Concerning Aggregation in Ecosystem Modeling." In *Theoretical Systems Ecology: Advances and Case Studies*, edited by Efraim Halfon, 55-76. New York, NY: Academic Press, 1979.
- [45] Campbell, D. "A Note on the Uncertainty in Estimates of Transformities Based on Global Water Budgets." Paper presented at the the Second Biennial Emergy Analysis Research Conference, Gainesville, FL, 2003.
- [46] Campbell, D.E. "Global Transition to Sustainable Development." Paper presented at the IV Biennial International Workshop "Advances in Energy Studies", Unicamp, Campinas, Brazil, 2004.
- [47] Çengel, Yunus A., Afshin J. Ghajar, and Louis A. Duhring Fund. *Heat and Mass Transfer : Fundamentals & Applications*. 4th ed. New York: McGraw-Hill, 2011.
- [48] Christensen, V. "Emergy-Based Ascendency." *Ecological Modelling* 72 (1994): 129-44.
- [49] Cleveland, C.J., R.K. Kaufmann, and D.I. Stern. "Aggregation and the Role of Energy in the Economy." *Ecological Economics* 32 (2000): 301-17.
- [50] Cornelissen, R., and G. Hirs. "Exergetic Optimization of a Heat Exchanger, Energy Conversion and Management." *Energy Conversion and Management* 38 (1997): 1567-76.
- [51] Costanza, Robert. "Ecological Economics: Reintegrating the Study of Humans and Nature." *Ecological Applications* 6, no. 4 (1996): 978-90.
- [52] Coupland, R.T., R.Y. Zacharuk, and E.A. Paul. "Procedures for Study of

- Grassland Ecosystems." In *The Ecosystem Concept in Natural Resource Management*, edited by G.M. Van Dyne. New York, NY: Academic Press, 1969.
- [53] Cronon, William. *Nature's Metropolis : Chicago and the Great West*. New York: W.W. Norton, 1991.
- [54] Cruz, J.L.G. "Southern States Outlaw Leed Building Standards." 2013.
- [55] Czech, B., and P.R. Krausman. "Implications of an Ecosystem Management Literature Review." *Wildlife Society Bulletin* 25, no. 3 (1997): 667-75.
- [56] Dews, A., and Sarah Wu. "Greenworks Philadelphia 2013 Progress Report." Philadelphia, PA: Mayor's office of Sustainability, 2013.
- [57] Diederer, André. *Global Resource Depletion*. Eburon, 2010.
- [58] Dincer, I., and Y.A. Cengel. "Energy, Entropy and Exergy Concepts and Their Roles in Thermal Engineering." *Entropy* 3 (2001): 116-49.
- [59] Eason, T., and H. Cabezas. "Evaluating the Sustainability of a Regional System Using Fisher Information in the San Luis Basin, Colorado." *Journal of Environmental Management* 94 (2012): 41-49.
- [60] Fabris, F. "Shannon Information Theory and Molecular Biology." *Journal of Interdisciplinary Mathematics* 12, no. 1 (2008): 41-87.
- [61] Fath, B.D., H. Cabezas, and C.W. Pawlowski. "Regime Changes in Ecological Systems: An Information Theory Approach." *Journal of Theoretical Biology* 222 (2003): 517-30.
- [62] Fath, B.D., and Bernard C. Patten. "Review of the Foundations of Network Environ Analysis." *Ecosystems* 2 (1999): 167-79.
- [63] Fay, R., G. Treloar, and U. Iyer-Raniga. "Life-Cycle Energy Analysis of Buildings: A Case Study." *Building Research & Information* 28, no. 1 (2000): 31-41.
- [64] Fernández-Galiano, L. "Architecture and Life." In *Architecture and Energy Performance and Style*, edited by W.W. Braham and D. Willis, 25-48. New York: Routledge, 2013.
- [65] ———. *Fire and Memory on Architecture and Energy*. Cambridge, MA: MIT Press, 2000.
- [66] Figueroa, M., H.C. Putra, and C.J. Andrews. "Preliminary Report: Incorporating Information on Occupant Behavior into Building Energy Models."

Philadelphia, PA: the Center for Green Building at Rutgers University for the Energy Efficient Buildings Hub, 2014.

- [67] Gallager, R.G. *Information Theory and Reliable Communication*. New York: John Wiley & Sons, 1968.
- [68] Gatenby, R.A., and B. Roy Frieden. "Information Theory in Living Systems, Methods, Applications, and Challenges." *Bulletin of Mathematical Biology* 69 (2007): 635-57.
- [69] Gill, D., and P. Bonnett. *Nature in the Urban Landscape: A Study of City Ecosystems*. Baltimore, MD: York Press, 1973.
- [70] Goerner, S.J., B. Lietaer, and R.E. Ulanowicz. "Quantifying Economic Sustainability: Implications for Free-Enterprise Theory, Policy and Practice." *Ecological Economics* 69, no. 1 (2009): 76-81.
- [71] Griffiths-Sattenspiel, Bevan, and Wendy Wilson. "The Carbon Footprint of Water." Portland, OR: River Network, 2009.
- [72] Gudmundsson, Agust, and Nahid Mohajeri. "Entropy and Order in Urban Street Networks." *Scientific Reports* 3 (2013): 1-8.
- [73] Guo, Hai, Lidia Morawska, Congrong He, and Dale Gilbert. "Impact of Ventilation Scenario on Air Exchange Rates and on Indoor Particle Number Concentrations in an Air-Conditioned Classroom." *Atmospheric Environment* 42, no. 4 (2008): 757-68.
- [74] Hall, C.A.S. "The Continuing Importance of Maximum Power." *Ecological Modelling* 178, no. 2004 (2004): 107-13.
- [75] Hassler, U., and N. Kohler. "Resilience in the Built Environment." *Building Research & Information* 42, no. 2 (2014): 119-29.
- [76] Hau, J.L., and B.R. Bakshi. "Expanding Exergy Analysis to Account for Ecosystem Products and Services." *Environmental Science Technology* 38, no. 13 (2004): 3768-77.
- [77] Hau, J.L., and B.R. Bakshi. "Promise and Problems of Emergy Analysis." *Ecological Modelling* 178 (2004): 215-25.
- [78] Haukoos, D.S. "Sustainable Architecture and Its Relationship to Industrial Building." University of Florida, 1995.
- [79] Hegel, G.W.F. *The Science of Logic*. Cambridge University Press, 2010, 1929.
- [80] Hirata, H., and R.E. Ulanowicz. "Information Theoretical Analysis of Ecological Networks." *International Journal of Systems Science* 15, no. 3 (1984): 261-70.

- [81] Ho, M.-W., and R.E. Ulanowicz. "Sustainable Systems as Organisms?". *Biosystems* 82 (2005): 39-51.
- [82] Holling, C.S. "Resilience and Stability of Ecological Systems." *Annual Review of Ecology and Systematics* 4 (1973): 1-24.
- [83] Hossaini, N., and K. Hewage. "Emergy Accounting for Regional Studies: Case Study of Canada and Its Provinces." *Journal of Environmental Management* 118, no. 1 (2013): 117-85.
- [84] Huang, S.L., H.Y. Lai, and C.L. Lee. "Energy Hierarchy and Urban Landscape System." *Landscape and Urban Planning* 53 (2001): 145-61.
- [85] Hudson, Amy, and David R. Tilley. "Assessment of Uncertainty in Emergy Evaluations Using Monte Carlo Simulations." *Ecological Modelling* 271 (2014): 52-61.
- [86] Ingwersen, W.W. "Uncertainty Characterization for Emergy Values." *Ecological Modelling* 221 (2010): 445-52.
- [87] Iwashita, G., and H. Akasaka. "The Effects of Human Behavior on Natural Ventilation Rate and Indoor Air Environment in Summer – a Field Study in Southern Japan." *Energy and Buildings* 25, no. 3 (1997): 195-205.
- [88] Jørgensen, S.E., and H. Mejer. "A Holistic Approach to Ecological Modelling." *Ecological Modelling* 7 (1979): 169-89.
- [89] Jørgensen, Sven Erik. *Integration of Ecosystem Theories : A Pattern*. Ecology & Environment. Dordrecht ; Boston: Kluwer Academic Publishers, 1992.
- [90] Jørgensen, Sven Erik, and Alumni and Friends Memorial Book Fund. *A New Ecology : Systems Perspective*. Amsterdam ; Oxford: Elsevier, 2007.
- [91] Jørgensen, Sven Erik, and Louis A. Duhring Fund. *Ecological Modelling : An Introduction*. Southampton, UK ; Boston: WIT Press, 2009.
- [92] Janssen, M.A., Ö . Bodin, J.M. Anderies, T. Elmqvist, H. Ernstson, R.R.J. McAllister, P. Olsson, and P. Ryan. "Towards a Network Perspective of the Study of Resilience in Social-Ecological Systems." *Ecology and Society* 11, no. 1 (2006).
- [93] Jaynes, E.T. "Information Theory and Statistical Mechanics." *Phys. Teach.* 106 (1957): 620-30.
- [94] Jones, C.M., and D.M. Kammen. "Quantifying Carbon Footprint Reduction Opportunities for U.S. Households and Communities." *Environmental Science Technology* 45, no. 9 (2011): 4088-95.

- [95] Karunanithi, A.T., H. Cabezas, B. Roy Frieden, and C.W. Pawlowski. "Detection and Assessment of Ecosystem Regime Shifts from Fisher Information." *Ecology and Society* 13, no. 1 (2008).
- [96] Kelly, K. *What Technology Wants*. New York: Penguin Books, 2011.
- [97] Kharrazi, A., S. Kraines, L. Hoang, and M. Yarime. "Advancing Quantification Methods of Sustainability: A Critical Examination Emergy, Exergy, Ecological Footprint, and Ecological Information-Based Approaches." *Ecological Indicators* 37 (2014): 81-89.
- [98] Kharrazi, A.; Rovenskaya, E.; Fath, B.D.; Yarime, M.; Kraines, S. "Quantifying the Sustainability of Economic Resource Networks: An Ecological Information-Based Approach." *Ecological Economics* 90 (2013): 177-86.
- [99] Koestler, A. *The Ghost in the Machine*. New York: Macmillan, 1967.
- [100] Lacarrière, Bruno, Kévin Ruben Deutz, Nadia Jamali-Zghal, and Olivier Le Corre. "Emergy Assessment of the Benefits of Closed-Loop Recycling Accounting for Material Losses." *Ecological Modelling* In Press (2015).
- [101] Landauer, R. "Information Is Physical." *Physics Today* (May 1991): 23-29.
- [102] Larsson, B. "Materialforbrukning Pa Byggarbetsplatsen." In *Building Economics and Construction Management*. Gothenburg, Sweden: Chalmers University Of Technology, 1983.
- [103] Latham, L.G. II, and E.P. Scully. "Quantifying Constraint to Assess Development in Ecological Networks." *Ecological Modelling* 154 (2002): 25-44.
- [104] Lee, Y.C., C.T. Yeh, and S.L. Huang. "Energy Hierarchy and Landscape Sustainability." *Landscape Ecology* 28 (2013): 1151-59.
- [105] Leff, H.S. "Removing the Mystery of Entropy and Thermodynamics—Part V." *Phys. Teach.* 50 (2012): 274-76.
- [106] Li, Linjun, Hongfang Lu, David R. Tilley, H. Ren, and W. Shen. "The Maximum Empower Principle: An Invisible Hand Controlling the Self-Organizing Development of Forest Plantations in South China." *Ecological Indicators* 29 (2013): 278-92.
- [107] Lindeman, R.L. "The Trophic-Dynamic Aspect of Ecology." *Ecology* 23, no. 399-418 (1942).
- [108] Liu, G., Z. Yang, B. Chen, and L. Zhang. "Analysis of Resource and Emission Impacts: An Emergy-Based Multiple Spatial Scale Framework for Urban

- Ecological and Economic Evaluation." *Entropy* 13 (2011): 720-43.
- [109] Liu, M., B. Li, and R. Yao. "A Generic Model of Exergy Assessment for the Environmental Impact of Building Lifecycle." *Energy and Buildings* 42, no. 9 (2010): 1482-90.
- [110] Lotka, A.J. *Elements of Physical Biology*. Baltimore, MD: Williams and Wilkins, 1925.
- [111] Lotka, Alfred J. "Natural Selection as a Physical Principle." *Proceedings of the National Academy of Sciences* 8 (1922): 151-54.
- [112] Lovelock, J. *Gaia: A New Look at Life on Earth*. Oxford, UK: Oxford University Press, 1979.
- [113] MacArthur, R. "Fluctuations of Animal Populations, and a Measure of Community Stability." *Ecology* 36 (1955): 533-36.
- [114] Marceau, M. L., and M. G. VanGeem. "Comparison of the Life Cycle Assessments of a Concrete Masonry House and a Wood Frame House." In *Research & Development Information: Portland Cement Association*, 2008.
- [115] Marchand, Bernard "Information Theory and Geography." *Geographical Analysis* 4, no. 3 (1972): 234-57.
- [116] Margalef, D.R. "La Teoria De La Informacion En Ecologia." [In Spanish]. *Mem. Real Acad. Ciencias Artes Barcelona* 32, no. 13 (1957): 373-449.
- [117] Martyushev, L.M. "Entropy and Entropy Production: Old Misconceptions and New Breakthroughs." *Entropy* 15 (2013): 1152-70.
- [118] May, Robert M. *Stability and Complexity in Model Ecosystems*. Monographs in Population Biology,. Princeton, N.J.,: Princeton University Press, 1973.
- [119] McDonough, William, and Michael Braungart. *Cradle to Cradle : Remaking the Way We Make Things*. 1st ed. New York: North Point Press, 2002.
- [120] Meadows, Donella H., and Club of Rome. *The Limits to Growth, a Report for the Club of Rome's Project on the Predicament of Mankind*. "A Potomac Associates Book ". New York,: Universe Books, 1972.
- [121] Meadows, Donella H., Jørgen Randers, and Dennis L. Meadows. *The Limits to Growth : The 30-Year Update*. White River Junction, Vt: Chelsea Green Pub., 2004.
- [122] Meadows, Donella H., and Diana Wright. *Thinking in Systems : A Primer*. White River Junction, Vt.: Chelsea Green Pub., 2008.
- [123] Medvedkov, Y.V. "The Concept of Entropy in Settlement Pattern Analysis."

- Regional Science* 18 (1967): 165-68.
- [124] Meillaud, F., J.-B. Gay, and M.T. Brown. "Evaluation of a Building Using the Emergy Method." *Solar Energy* 79, no. 2 (2005): 204-12.
- [125] Mellino, S., M. Ripa, A. Zucaro, and S. Ulgiati. "An Emergy-Gis Approach to the Evaluation of Renewable Resource Flows: A Case Study of Campania Region, Italy." *Ecological Modelling* 271 (2014): 103-12.
- [126] Meysman, F.J.R., and S. Bruers. "Ecosystem Functioning and Maximum Entropy Production: A Quantitative Test of Hypothesis." *Philosophical Transactions of the Royal Society B* 365 (2010): 1405-16.
- [127] Moran, M., and H. Shapiro. *Fundamentals of Engineering Thermodynamics*. 4th ed. Hoboken: John Wiley & Sons Inc., 2000.
- [128] Morandi, F., D.E. Campbell, R.M. Pulselli, and S. Bastianoni. "Using the Language of Sets to Describe Nested Systems in Emergy Evaluations." *Ecological Modelling* 265 (2013): 85-98.
- [129] Nicolis, G., and I. Prigogine. *Self-Organization in Nonequilibrium Systems : From Dissipative Structures to Order through Fluctuations*. New York: Wiley, 1977.
- [130] Odum, Eugene Pleasants. *Basic Ecology*. Philadelphia: Saunders College Pub., 1983.
- [131] ———. *Fundamentals of Ecology*. Philadelphia,: Saunders, 1953.
- [132] ———. "The Strategy of Ecosystem Development." *Science* 164, no. 3877 (1969): 262-70.
- [133] Odum, H.T. "Limits of Remote Ecosystems Containing Man." *The American Biology Teacher* 25, no. 6 (1963): 429-43.
- [134] ———. "Self-Organization and Maximum Empower." In *Maximum Power: The Ideas and Applications of H.T. Odum*, edited by C. Hall, 311-30. Niwot: University of Colorado, 1995.
- [135] Odum, H.T., M.T. Brown, and S. Brandt-Williams. "Folio #1: Introduction and Global Budget." In *Handbook of Emergy Evaluation, A Compendium of Data for Emergy Computation Issued in a Series of Folios*, 16. Gainesville, FL: Center for Environmental Policy, University of Florida, 2000.
- [136] Odum, H.T., M.T. Brown, D.F. Whitfield, S. Lopez, R. Woihe, and S. Doherty.

- "Zonal Organization of Cities and Environment." Taipei, Taiwan: Unpublished report to the Chiang Ching-Kuo International Scholar Exchange Foundation, 1995.
- [137] Odum, H.T., and R.C. Pinkerton. "Time's Speed Regulator: The Optimum Efficiency for Maximum Power Output in Physical and Biological Systems." *American Scientist* 43, no. 2 (1955): 331-43.
- [138] Odum, H.T., F.C. Wang, J.F. Alexander, M. Gilliland, M. Miller, and J. Sendzimer. "Energy Analysis of Environmental Value." Center for Wetland, University of Florida, 1987.
- [139] Odum, Howard T. "Emergy Evaluation." In *International Workshop on Advances in Energy Studies: Energy flows in ecology and economy*. Porto Venere, Italy, 1998.
- [140] ———. *Environment, Power and Society*. New York, NY: John Wiley & Sons Inc., 1971.
- [141] ———. *Environment, Power and Society for the Twenty-First Century: The Hierarchy of Energy*. New York, NY: Columbia University Press, 2007.
- [142] ———. *Environmental Accounting : Emergy and Environmental Decision Making*. New York: John Wiley and Sons Inc., 1996.
- [143] ———. "Self-Organization, Transformity, and Information." *Science* 242, no. 4882 (1988): 1132-39.
- [144] Odum, Howard T., and Elisabeth C. Odum. *Energy Basis for Man and Nature*. New York: McGraw-Hill, 1976.
- [145] Offermann, F., S. Brennan, A. Hodgson, and P. Jenkins. "Window Usage, Ventilation, and Formaldehyde Concentrations in New California Homes." Paper presented at the Indoor Air 2008: The 11th International Conference on Indoor Air Quality and Climate, Copenhagen, Denmark, 2008.
- [146] Oğulata, R.T. "The Effect of Thermal Insulation of Clothing on Human Thermal Comfort." *FIBRES & TEXTILES in Eastern Europe* 15, no. 2 (2007): 67-72.
- [147] PAGE, Jessen. "Simulating Occupant Presence and Behaviour in Buildings." Doctoral Dissertation, École polytechnique fédérale de Lausanne, 2007.
- [148] Peacock, K. "Staying out of the Lifeboat: Sustainability, Culture, and the Thermodynamics of Symbiosis." *Ecosystem health* 5, no. 2 (1999): 91-103.

- [149] Preston, F.W. "The Commonness and Rarity of Species." *Ecology* 29 (1948): 254-83.
- [150] Prigogine, I. *Is Future Given?* River Edge, NJ: World Scientific, 2003.
- [151] Pulselli, R.M., E. Simoncini, and N. Marchettini. "Energy and Emergy Based Cost-Benefit Evaluation of Building Envelopes Relative to Geographical Location and Climate." *Building and Environment* 44 (2009): 920-28.
- [152] Pulselli, R.M., E. Simoncini, F.M. Pulselli, and S. Bastianoni. "Emergy Analysis of Building Manufacturing, Maintenance and Use: Em-Building Indices to Evaluate Housing Sustainability." *Energy and Buildings* 39 (2007): 620-28.
- [153] Quastler, Henry. *Essays on the Use of Information Theory in Biology*. Associate Editors: Leroy Angenstine [and Others]. Urbana,: University of Illinois Press, 1953.
- [154] Raugei, M., S. Bargigli, and S. Ulgiati. "Technological Improvement and Innovation in Photovoltaics-New Emergy Calculations." Paper presented at the the Fourth Biennial Emergy Conference, Gainesville, Florida, 2006.
- [155] Raugei, M., B. Rugani, E. Benetto, and W. Ingwersen. "Integrating Emergy into Lca: Potential Added Value and Lingering Obstacles." *Ecological Modelling* 271 (2014): 4-9.
- [156] Reed, M., E.D.G. Fraser, S. Morse, and A.J. Dougill. "Integrating Methods for Developing Sustainability Indicators to Facilitate Learning and Action." *Ecology and Society* 10, no. 1 (2005).
- [157] Reza, B., R. Sadiq, and K. Hewage. "Emergy-Based Life Cycle Assessment(Em-Lca) of Multi-Unit and Single-Family Residential Buildings in Canada." *International Journal of Sustainable Built Environment* In Press (2014).
- [158] Rijal, H.B., P. Tuohy, M.A. Humphreys, J.F. Nichol, A. Samuel, and J. Clarke. "Using Results from Field Surveys to Predict the Effect of Open Windows on Thermal Comfort and Energy Use in Buildings." *Energy and Buildings* 39, no. 7 (2007): 823-36.
- [159] Rothrock, H. "Sustainable Housing: Emergy Evaluation of an Off-Grid Residence." *Energy and Buildings* 85 (2014): 287-92.
- [160] Rustagi, N., David R. Tilley, and J. Schramski. "Total Energy Requirements of a Living Extensive Green Roof." Paper presented at the the Fifth Biennial Emergy Conference, Gainesville, Florida, 2008

- [161] Rutledge, R.W., B.L. Basore, and R.J. Mulholland. "Ecological Stability: An Information Theory View Point." *Journal of Theoretical Biology* 57 (1976): 355-71.
- [162] Schneider, E.D., and J.J. Kay. "Complexity and Thermodynamics: Towards a New Ecology." *Futures* 26, no. 6 (1994): 626-47.
- [163] ———. "Life as Manifestation of the Second Law of Thermodynamics." *Mathl. Comput. Modelling* 19, no. 6-8 (1994): 25-48.
- [164] Schrödinger, Erwin. *What Is Life? The Physical Aspect of the Living Cell*. Cambridge Eng.: The University press, 1945.
- [165] Schultz, A.M. "A Study of an Ecosystem: The Arctic Tundra." In *The Ecosystem Concept in Natural Resource Management*, edited by G.M. Van Dyne. New York, NY: Academic Press, 1969.
- [166] Shannon, C.E. "The Bandwagon." *IEEE Transactions on Information Theory* 2 (1956).
- [167] ———. "A Mathematical Theory of Communication." *The Bell System Technical Journal* 27 (1948): 379-423.
- [168] Shukuya, M. "Energy, Entropy, Exergy and Space Heating Systems." Paper presented at the the 3rd International Conference 'Healthy Buildings' 94, 1994.
- [169] Siniavskaia, Natalia "Spending Patterns of Home Buyers." HousingEconomics.com, 2008.
- [170] Smith, A., and A. Stirling. "Social-Ecological Resilience and Sociotechnical Transitions: Critical Issues for Sustainability Governance." In *STEPS Working Paper 8*. Brighton: STEPS Centre, 2008.
- [171] Srinivasan, R.S., W.W. Braham, D.E. Campbell, and C.D. Curcija. "Re(De)Fining Net Zero Energy: Renewable Energy Balance in Environmental Building Design." *Building and Environment* 47 (2012): 300-15.
- [172] Srinivasan, R.S., W. Ingwersen, C. Trucco, R. Ries, and D. Campbell. "Comparison of Energy-Based Indicators Used in Life Cycle Assessment Tools for Buildings." *Building and Environment* 79 (2014): 138-51.
- [173] Steadman, Philip. *The Evolution of Designs : Biological Analogy in Architecture and the Applied Arts*. Cambridge Urban and Architectural Studies. Cambridge ; New York: Cambridge University Press, 1979.

- [174] Stepanic, J., H. Stefancic, M.S. Zebec, and K. Perackovic. "Approach to a Quantitative Description of Social Systems Based on Thermodynamic Formalism." *Entropy* 2 (2000): 98-105.
- [175] Stokols, D., R.P. Lejano, and J. Hipp. "Enhancing the Resilience of Human-Environment Systems: A Social Ecological Perspective." *Ecology and Society* 18, no. 1 (2013): 7.
- [176] Stoy, P.C. "Thermodynamic Approaches to Ecosystem Behavior: Fundamental Principles with Case Studies from Forest Succession and Management." In *Ecosystem Ecology: A New Synthesis*, edited by D. G. Raffaelli, Chris Frid and Rudolph G. Schmieder Fund. Ecological Reviews, 40-64. Cambridge; New York: Cambridge University Press, 2010.
- [177] Swenson, R. "Autocatakinetics, Evolution, and the Law of Maximum Entropy Production: A Principled Foundation Towards the Study of Human Ecology." *Advances in Human Ecology* 6 (1997): 1-47.
- [178] Szargut, J., D.R. Morris, and F.R. Steward. *Exergy Analysis of Thermal, Chemical and Metallurgical Processes*. New York, NY: Hemisphere, 1988.
- [179] Tansley, A.G. "The Use and Abuse of Vegetational Concepts and Terms." *Ecology* 16, no. 3 (1935): 284-307.
- [180] Thims, L. "Thermodynamics≠Information Theory: Science's Greatest Sokal Affair." *Journal of Human Thermodynamics* 8, no. 1 (2012): 1-120.
- [181] Thormark, C. "A Low Energy Building in a Life Cycle-Its Embodied Energy, Energy Need for Operation and Recycling Potential." *Building and Environment* 37 (2002): 429-35.
- [182] Tilley, David R. "Howard T. Odum's Contribution to the Laws of Energy." *Ecological Modelling* 178 (2004): 121-25.
- [183] Tilley, David R. and Thompson, R. "A New Generative Index based on emergy analysis and Shannon information for assessing the resilience of green systems." 15th Annual AEES Meeting, Stillwater, OK.
- [184] Toussaint, O., and E.D. Schneider. "The Thermodynamics and Evolution of Complexity in Biological Systems." *Comparative Biochemistry and Physiology Part A* 120, no. 3-9 (1998).
- [185] Tribus, M., and E.C. McIrvine. "Energy and Information." *Scientific American* 224 (1971): 178-84.
- [186] Ukidwe, N.U., and B.R. Bakshi. "Thermodynamic Input-Output Analysis of

- Economic and Ecological Systems with Application to the U.S. Economy." Paper presented at the the 3rd emergy conference, Gainesville, FL, 2005.
- [187] Ulanowicz, R.E. "An Hypothesis on the Development of Natural Communities." *Journal of theoretical Biology* 85 (1980): 223-45.
- [188] ———. "Information Theory in Ecology." *Computers and Chemistry* 25 (2002): 393-99.
- [189] Ulanowicz, R.E., S.J. Goerner, B. Lietaer, and R. Gomez. "Quantifying Sustainability: Resilience, Efficiency and the Return of Information Theory." *Ecological Complexity* 6 (2009): 27-36.
- [190] Ulanowicz, R.E., and B. Hannon. "Life and the Production of Entropy." *Proceedings of the Royal Society of London B* 232 (1987): 181-92.
- [191] Ulanowicz, Robert E. *Ecology, the Ascendent Perspective / Robert E. Ulanowicz*. Complexity in Ecological Systems Series. New York: Columbia University Press, 1997.
- [192] ———. *Growth and Development : Ecosystems Phenomenology*. New York: Springer-Verlag, 1986.
- [193] Ulgiati, S., S. Bargigli, and M. Raugeri. "Dotting the I's and Crossing the T's of Emergy Synthesis: Material Flows, Information and Memory Aspects, and Performance Indicators." Paper presented at the the 3rd Emergy Conference, Gainesville, FL, 2005.
- [194] ———. "An Emergy Evaluation of Complexity, Information and Technology, Towards Maximum Power and Zero Emissions." *Journal of Cleaner Production* 15, no. 13 (2007): 1359-72.
- [195] US EPA. "Warm Definitions and Acronyms."
<http://www.epa.gov/epawaste/conserva/tools/warm/pdfs/warm-definitions-and-acronyms.pdf>.
- [196] Van der Ryn, Sim, and Stuart Cowan. *Ecological Design*. Washington, D.C.: Island Press, 1996.
- [197] Walker, M., ed. *Science and Ideology: A Comparative History*. New York: Routledge, 2002.
- [198] Walsh, J.A., and M.E. O'Kelly. "An Information Theoretic Approach to Measurement of Spatial Inequality." *Economic and Social Review* 10, no. 4

- (1979): 267-86.
- [199] WCED. *Our Common Future*. New York: Oxford University Press, 1987.
- [200] Weaver, Warren. "Science and Complexity." *American Scientist* 36 (1948).
- [201] White, L.A. *The Science of Culture: A Study of Man and Civilization*. New York: Grove Press, 1949.
- [202] Wiener, Norbert. *Cybernetics: Or Control and Communication in the Animal and the Machine*. New York, NY: John Wiley & Sons, Inc., 1948.
- [203] Williams, C.B. "The Logarithmic Series and Its Application to Biological Problems." *Journal of Ecology* 34, no. 2 (1947): 253-72.
- [204] Wilson, A.G. "A Statistical Theory of Spatial Distribution Models." *Transportation Research* 1, no. 3 (1967): 253-69.
- [205] Yi, H., R.S. Srinivasan, and W.W. Braham. "An Integrated Energy-Emergy Approach to Building Form Optimization: Use of Energyplus, Emergy Analysis and Taguchi-Regression Method." *Building and Environment* 84 (2015): 89-104.
- [206] Yuan, F., L.Y. Shen, and Q.M. Li. "Emergy Analysis of the Recycling Options for Construction and Demolition Waste." *Waste Management* 31 (2011): 2503-11.
- [207] Zari, Maibritt Pedersen. "Ecosystem Processes for Biomimetic Architectural and Urban Design." *Architectural Science Review* 58, no. 2 (2015): 106-19.
- [208] Zhang, Y. "Urban Metabolism: A Review of Research Methodologies." *Environmental Pollution* 178 (2013): 463-73.
- [209] Zhang, Y., A. Baral, and B.R. Bakshi. "Accounting for Ecosystem Services in Life Cycle Assessment, Part II: Toward an Ecologically Based Lca." *Environmental Science Technology* 44, no. 7 (2010): 2624-31.
- [210] Zhang, Y., S. Singh, and B.R. Bakshi. "Accounting for Ecosystem Services in Life Cycle Assessment, Part I: A Critical Review." *Environmental Science Technology* 44, no. 7 (2010): 2232-42.
- [211] Zhang, Y., Z. Yang, and W. Li. "Analyses of Urban Ecosystem Based on Information Entropy." *Ecological Modelling* 197 (2006): 1-12.
- [212] Zhang, Y., Z. Yang, and X. Yu. "Ecological Network and Emergy Analysis of Urban Metabolic Systems: Model Development, and a Case Study of Four Chinese Cities." *Ecological Modelling* 220 (2009): 1431-42.
- [213] Zhou, J., S. Ma, and G.W. Hinman. "Ecological Exergy Analysis: A New

Method for Ecological Energetic Research." *Ecological Modelling* 84 (1996): 291-303.

- [214] Ziegler, Hans. "Some Extremum Principles in Irreversible Thermodynamics with Application to Continuum Mechanics." In *Progress in Solid Mechanics*, edited by I.N. Sneddon and R. Hill. Amsterdam, Holland: North-Holland, 1963.