



2016

Architectural Precast Concrete Wall Panels: Their Technological Evolution, Significance, and Preservation

Grace Meloy

University of Pennsylvania, gameloy36@gmail.com

Follow this and additional works at: http://repository.upenn.edu/hp_theses

 Part of the [Historic Preservation and Conservation Commons](#)

Meloy, Grace, "Architectural Precast Concrete Wall Panels: Their Technological Evolution, Significance, and Preservation" (2016). *Theses (Historic Preservation)*. Paper 608.

http://repository.upenn.edu/hp_theses/608

Suggested Citation:

Meloy, Grace (2016). *Architectural Precast Concrete Wall Panels: Their Technological Evolution, Significance, and Preservation*. (Masters Thesis). University of Pennsylvania, Philadelphia, PA.

This paper is posted at ScholarlyCommons. http://repository.upenn.edu/hp_theses/608

For more information, please contact repository@pobox.upenn.edu.

Architectural Precast Concrete Wall Panels: Their Technological Evolution, Significance, and Preservation

Abstract

Architectural precast concrete wall panels played an important role in mid-twentieth century architecture by providing a concrete technology that could be applied to the curtain wall system of construction utilized in this time period. Moreover, the precasting process, which enabled the controlled production of expressive facing concrete mixes and surface treatments and finishes, made this a concrete technology that could contribute to the architectural expression of the building. To promote the preservation of these panels, this thesis investigates and illuminates their historical and architectural significance in the United States in the mid-twentieth century.

There are, however, numerous technical challenges to the physical preservation of architectural precast wall panels, the most significant of which is due to their specially designed concrete mix and surface finish. Given the importance of preserving these characteristics, the general retroactive preservation action of applying patches to deteriorated concrete is unsatisfactory; instead, we must adopt a preventive approach. Towards this end, this thesis examines documents published in the United States between 1945 and 1975 that informed the design, production, and assembly of architectural precast wall panels. The information from these documents is used to trace the technological evolution of these panels and, ultimately, to identify potential material vulnerabilities and associated deterioration mechanisms to which they may be subject. This methodology provides foundational information to be used in the creation of preventive conservation plans for buildings constructed with this concrete technology.

Keywords

cast stone, concrete masonry units, American Concrete Institute, Precast/Prestressed Concrete Institute, MoSai

Disciplines

Historic Preservation and Conservation

Comments

Suggested Citation:

Meloy, Grace (2016). *Architectural Precast Concrete Wall Panels: Their Technological Evolution, Significance, and Preservation*. (Masters Thesis). University of Pennsylvania, Philadelphia, PA.

**ARCHITECTURAL PRECAST CONCRETE WALL PANELS:
THEIR TECHNOLOGICAL EVOLUTION, SIGNIFICANCE, AND PRESERVATION**

Grace Meloy

A THESIS

in

Historic Preservation

Presented to the Faculties of the University of Pennsylvania in
Partial Fulfillment of the Requirements of the Degree of

MASTER OF SCIENCE IN HISTORIC PRESERVATION

2016

Advisor
Michael C. Henry, PE, AIA
Adjunct Professor of Architecture

Program Chair
Randall F. Mason, PhD
Associate Professor

ACKNOWLEDGEMENTS

First and foremost, I would like to thank my advisor Michael C. Henry, PE, AIA. He pushed me throughout this thesis process, and throughout my two years in the University of Pennsylvania's Historic Preservation program more broadly, to always think critically and consider how the gap between engineering and preservation may be bridged. This thesis allowed me to explore both of these fields, and Michael Henry's encouragement was essential.

I would also like to thank Randall Mason, Frank Matero, and the rest of the Historic Preservation faculty for their guidance and support over the last two years. From their teaching, I have learned more about preservation than I could have ever imagined.

Additionally, I would like to thank my classmates for all of the wonderful and critical conversations we have had, and I hope we will continue to have, about preservation and its place in the world. It has been a pleasure to work with you.

Finally, I want to thank my family and friends for their efforts to appreciate my interest in preserving concrete; I hope this topic has become a little more intriguing after all of our conversations. In particular, Alex Host read and edited my thesis in its entirety, and for that I am exceedingly grateful.

TABLE OF CONTENTS

ACKNOWLEDGEMENTS.....	II
LIST OF FIGURES	V
LIST OF TABLES.....	VII
CHAPTER 1: INTRODUCTION.....	1
CHAPTER 2: EARLY PRECAST CONCRETE BUILDING PRODUCTS—THE DEVELOPMENT OF ARCHITECTURAL PRECAST WALL PANELS.....	6
Introduction	6
History of Reinforced Concrete.....	6
Obstacles to Architectural Use of Reinforced Concrete	8
The Predecessors of Architectural Precast Wall Panels	12
Nascent Architectural Precast Wall Panels	16
World War II and Concrete	22
Conclusion.....	23
CHAPTER 3: APPLICATION OF ARCHITECTURAL PRECAST WALL PANELS IN MID-CENTURY ARCHITECTURE.....	24
Development of the Curtain Wall System.....	24
Flourishing of Architectural Precast Wall Panels.....	29
Modernist Architects and Architectural Precast Wall Panels.....	31
Variety of Buildings and Aesthetics.....	37
Preservation Implications	45
CHAPTER 4: LITERATURE REVIEW—PATHOLOGIES AND PRESERVATION OF ARCHITECTURAL PRECAST WALL PANELS	48
Introduction	48
Reinforced Concrete Pathologies	48
Deterioration of Architectural Precast Wall Panels	53
Deterioration Detection Methods	55
Current Architectural Precast Wall Panel Preservation Strategies	57
Conservation Strategies with Potential	58
Towards a Preventive Conservation Approach.....	61
Conclusion.....	64
CHAPTER 5: TECHNOLOGICAL EVOLUTION OF ARCHITECTURAL PRECAST WALL PANELS, 1945-1975	65
Introduction	65
Precast’s Potential: 1945-1950.....	67
1950-1965: Pre-ACI Symposium.....	68
1965 ACI Symposium	74
1965-1975: Momentum in the Architectural Precast Industry.....	87
Conclusion.....	106

CHAPTER 6: METHODOLOGY FOR PREVENTIVE CONSERVATION OF ARCHITECTURAL PRECAST WALL PANELS	107
Introduction	107
Methodology Part 1—Categorizing Industry Literature	107
Data.....	108
Discussion	126
Methodology Part 2—Identification of Potential Factors and Paths to Deterioration ..	127
Application of Methodology and Future Steps	138
Conclusion.....	140
CHAPTER 7: CONCLUSION	141
BIBLIOGRAPHY	144
Mid-century Modern, Concrete, and Its Preservation	144
History of Reinforced Concrete.....	144
History and Development of Architectural Precast Concrete Wall Panels	145
Application of Architectural Precast Concrete Wall Panels in Mid-Century Architecture	146
Reinforced Concrete: Pathologies and Preservation.....	146
Architectural Precast Wall Panels: Pathologies and Preservation.....	148
Preventive Conservation	149
Recommended Practices and Other Technical Documents About Architectural Precast Concrete Wall Panels	149
INDEX.....	152

LIST OF FIGURES

Figure 1. Detail of the concrete façade of the Blenheim building of the Marlborough-Blenheim Hotel in Atlantic City, NJ (1905).

Figure 2. Cast stone column capitols.

Figure 3. An “honestly modern” house composed of all concrete components, including unstuccoed exterior walls of concrete masonry units.

Figure 4. The Armestone System.

Figure 5. The Lockstone System.

Figure 6. Lake Shore Drive Apartments by Mies van der Rohe (Chicago, 1948-1951).

Figure 7. The Seagram Building by Mies van der Rohe (New York City, 1954-1958).

Figure 8. Example of window-type mullion wall on the Pan American Building in NYC (1962).

Figure 9. The Denver Hilton Hotel by Aldo Cossutta (Denver, CO, 1959).

Figure 10. Murray Lincoln Campus Center by Marcel Breuer and Herbert Beckhard (University of Massachusetts in Amherst, MA, 1970).

Figure 11. The Pan American Building by Walter Gropius and Pietro Belluschi (New York City, 1962).

Figure 12. The Philadelphia Police Headquarters by Geddes, Brecher, Qualls, and Cunningham (Philadelphia, 1962).

Figure 13. The Northeast Regional Library by Geddes, Brecher, Qualls, and Cunningham (Philadelphia, 1962).

Figure 14. The Buffalo Evening News Building by Edward Durell Stone and Associates (Buffalo, NY, 1973).

Figure 15. Walters Art Museum addition by Shepley, Bulfinch, Richardson, and Abbot of Boston and Meyer, Ayres, and Saint of Baltimore (Baltimore, 1974).

Figure 16. Banker Trust Building by Emory Roth and Sons (New York City, 1962)

Figure 17. Water Tower Inn by Hausner and Macsai (Chicago, 1961).

Figure 18. The International Building by Anshen and Allen (San Francisco, 1961).

Figure 19. McGaw Memorial Hall by Holabird & Root & Burgee (Northwestern University in Evanston, IL, 1953)

Figure 20. The Oak Park High School, architect unknown (Laurel, MS, c. 1965).

Figure 21. The Samuel Paley Library by Nolen & Swinburne (Philadelphia, 1966).

Figure 22. The Miami Beach Public Library by Herbert A. Mathes (Miami Beach, FL, 1962).

Figure 23. Diagram of concrete deterioration.

Figure 24. Detail of a joint that convolutes the path water must travel to penetrate the wall system.

Figure 25. Temperature gradient through different types of panels.

Figure 26. A precaster laying wire mesh reinforcement onto precast panel before applying the backup concrete.

Figure 27. Images of different textures that can be achieved with the use of form liners.

Figure 28. A precaster hand laying the facing aggregate in the formwork.

Figure 29. Comparison of different methods of exposing the facing aggregate.

Figure 30. Example of a positive seating connection between an architectural precast wall panel and a concrete frame.

Figure 31. Comparison of the strain experienced by the sealant material in joints of different shape factors.

Figure 32. Examples of two-stage joint systems.

LIST OF TABLES

Table 1. Design Objectives

Table 2. Material Selection

Table 3. Reinforcement Design and Materials

Table 4. Form Design and Materials

Table 5. Casting and Consolidation

Table 6. Curing, Stripping, and Storage

Table 7. Surface Finishes and Treatments

Table 8. Transport, Handling, and Erection

Table 9. Connection Design and Materials

Table 10. Joint Design and Materials

Table 11. Cleaning, Repairs, and Coatings

Table 12. Panel Design Conditions

Table 13. Facing and Backup Concrete Mix Conditions

Table 14. Concrete Cover and Reinforcement Conditions

Table 15. Formwork, Casting, Curing, and Surface Treatment Conditions

Table 16. Stripping and Handling Conditions

Table 17. Connection and Joint Conditions

CHAPTER 1: INTRODUCTION

Although reinforced concrete (RC) became one of the primary structural materials for industrial and infrastructural projects in the late nineteenth century, it took decades for RC to become an accepted and even celebrated architectural building material. Vital to this acceptance was the development of architectural precast concrete wall panels, which provided architects of the mid-twentieth century with a concrete technology that could attain a variety of architectural expressions and more effectively compete with mid-century architecture's other defining material, steel. Unfortunately, their preservation has been inhibited, on the one hand, by a limited understanding, evident in the literature, of their historical and architectural significance and, on the other hand, by the numerous technical challenges associated with their physical preservation, including that of preserving the original architectural expression of the panels. This thesis seeks to contribute to the preservation of architectural precast concrete wall panels by addressing these impediments.

Architectural precast wall panels are envelope components that are connected to the primary structural frame of a building. Their structural function is limited to supporting their own dead load and resisting lateral loads, such as wind, and they thereby conform to the mid-century trend of separating a building's skin from its structure. They are generally manufactured off-site, which enables greater control over the production process and the quality of the product than what can be achieved with cast-in-place concrete, which is subject to weather, variable curing conditions, and the inaccuracies of formwork erected on-site. Architectural precast wall panels are cast horizontally in reusable forms with a thin layer of a facing concrete typically poured first, on top of which reinforcement is placed, followed by a backup layer of concrete.

Significantly, the facing concrete was designed to fulfill an architectural function: through a particular concrete mix design and an expressive surface finish and/or treatment, it is able to contribute to the architectural expression of the building. The panels can also be cast into interesting and artistic shapes to further add to this expression. As a result, architectural precast wall panels contribute immensely to the character of the buildings constructed with them, and preserving their application in mid-century architecture will be integral to the preservation of our mid-century heritage more broadly.

Beyond our limited awareness of architectural precast wall panels' historical and architectural significance, there are also numerous technical challenges to their preservation. The preservation of all reinforced concrete is challenging because of the way it deteriorates from the inside out, due to the corrosion of the internal reinforcement. Corrosion results in the volumetric expansion of the reinforcement and, subsequently, the cracking of the adjacent concrete and, ultimately, spalling of the concrete surface. When this occurs, repair and conservation strategies have been limited to, most conservatively, patching the localized section of spalling or, more liberally, demolishing the wall and rebuilding it. Although patches preserve more historic fabric than demolition, they are extremely difficult to match and are often highly visible, to the detriment of the building's design.

The preservation of architectural precast wall panels in particular, however, presents further challenges. Precast wall panels have thinner sections, which provide less cover over the reinforcement and can lead to bending problems. Due to the modularity of precast wall panel systems, there are many joints, unlike in cast-in-place concrete walls. These joints between the panels create more concrete surface area that is subject to moisture penetration. Moreover, the connection assemblies between the panels and the

building's structural frame introduce paths for thermal conduction and sites of additional corrosion.

The most significant challenge in preserving architectural precast wall panels is due to their specially designed concrete mix, surface finish, and/or panel shape, which combine to help define the architectural expression of the building. That this concrete technology allowed for more imaginative results than precast panels' main competitor, metal and glass curtain walls, and more consistent results than could be achieved with cast-in-place concrete, is what made it so attractive to architects of the mid-twentieth century. Given the importance of preserving this architectural expression, the general retroactive preservation action of applying patches to deteriorated concrete is unsatisfactory. Instead, it is essential that we adopt a preventive conservation approach, or a conservation approach that attempts to predict and slow the rate of deterioration. By predicting problems and taking measures to slow deterioration before the material integrity of this important element is compromised, the important architectural role of precast wall panels will be more successfully preserved.

This thesis will first illuminate the historical significance of architectural precast wall panels within the context of the development of reinforced concrete and its competition with steel and, later, metal and glass curtain walls. Then, to illustrate the architectural significance of architectural precast wall panels, this thesis will present examples of their application in mid-century architecture and explore their role as a character-defining feature. Lastly, after emphasizing the need for preventive conservation strategies for buildings constructed with architectural precast wall panels, this thesis will analyze recommended practices and other technical documents that informed their design, production, and assembly in order to predict what material vulnerabilities and subsequent deterioration they may be subject to. By identifying the potential array of threats that may

affect this concrete technology, this thesis hopes to provide information that may be used in the development of such preventive conservation plans.

In designing this thesis, several important scope limitations were established. First, this thesis will only focus on architectural precast concrete wall panels and saves the exploration of structural precast wall panels for future research. Similarly, sandwich panels will not be examined in great detail in this thesis because of the numerous challenges particular to that type of wall panel; they should also be explored in a related but separate project. Second, the recommended practices and other technical documents analyzed to predict how architectural precast wall panels may deteriorate are limited to those published between 1945 and 1975 in the United States during this period. These dates were determined based on the significant use of architectural precast wall panels during the mid-twentieth century: after World War II (1945) when architectural precast wall panels began to be mass produced and before the decline of mid-century architecture (1975), the period of architecture to which architectural precast wall panels greatly contributed. This thesis focuses on the United States because of the author's interest in American mid-century architecture and her familiarity with American building practices. Finally, this thesis hopes to be thorough but does not pretend to be exhaustive with respect to reviewing all of the documents published about the design, production, and assembly of architectural precast wall panels during the mid-twentieth century in the United States. However, through an examination of the publications of organizations such as the American Concrete Institute, which has been and continues to be one of the leading authorities in concrete technology, the most influential documents have been identified and reviewed.¹

¹ It should be noted that during the research for this thesis, numerous dead ends were encountered in attempting to find potentially significant documents about the design, production, and assembly of architectural precast wall panels. This reveals that information about this important mid-century architectural feature is already being lost, and, consequently, we must bolster our understanding of this concrete technology while we still have as much information as we do to better preserve it in the future.

Chapter 2: Early Precast Concrete Building Products—The Development of Architectural Precast Wall Panels explores the history of reinforced concrete, significant predecessors of precast panels, and early precast panels produced prior to World War II in order to elucidate the evolution of this concrete technology and reveal its historical significance. Chapter 3: Application of Architectural Precast Wall Panels in Mid-Century Architecture examines the development of the curtain wall system and its significance to the application of architectural precast wall panels in mid-century architecture. To demonstrate the architectural significance of this concrete technology, examples of its application in mid-century architecture are presented, followed by a discussion of important implications for the preservation of architectural precast wall panels. Chapter 4: Literature Review—Pathologies and Preservation of Architectural Precast Wall Panels reviews the current state of knowledge about the mechanisms of deterioration that affect architectural precast wall panels and the strategies implemented in their preservation. This chapter exposes the shortcomings of these preservation strategies and proposes the adoption of a preventive conservation approach. Chapter 5: Technological Evolution of Architectural Precast Wall Panels, 1945-1975, investigates the ways in which the design, production, and assembly of this concrete technology changed over this thirty year period, assembling the information that will be used to identify potential material vulnerabilities of architectural precast wall panels. Chapter 6: Methodology for Preventive Conservation of Architectural Precast Wall Panels, analyzes the technological evolution of architectural precast wall panels within the context of the pathologies that affect them and that affect reinforced concrete more broadly. The results of this analysis are presented in tables and diagrams that outline the various factors and paths of deterioration that could affect this concrete technology. This information will be essential in the creation of preventive conservation plans for buildings constructed with this architectural element.

CHAPTER 2: EARLY PRECAST CONCRETE BUILDING PRODUCTS—THE DEVELOPMENT OF ARCHITECTURAL PRECAST WALL PANELS

INTRODUCTION

The emergence of reinforced concrete as a primary architectural building material in the mid-twentieth century owes much to the development of architectural precast concrete wall panels. The precasting process enabled a high level of control over the production of this concrete technology, thereby enhancing its competitiveness with America's previously favored material: steel. By examining the development of architectural precast wall panels, including its contribution to the architectural use and acceptance of concrete, the historical significance of this concrete technology and the importance of preserving it can be fully appreciated.

HISTORY OF REINFORCED CONCRETE

A brief review of the history of reinforced concrete (RC) is essential for understanding the evolution of architectural precast wall panels. After concrete's initial use by the Romans, there was a "total neglect of concrete construction" until the beginning of the nineteenth century when concrete emerged as a modern building material almost simultaneously in England and France, with the United State following in the second half of the nineteenth century.²

The neglect of concrete can be partially attributed to the absence of a good binder, which, when mixed with water, forms the paste and ultimately the matrix to bond the coarse and fine aggregates of the concrete mix. Accordingly, the discovery of a better binder

² Peter Collins, *Concrete: The Vision of a New Architecture* (McGill-Queens University Press, 2004, originally published 1959): 19.

was essential to the development of concrete as a building material in the nineteenth century. In 1824, such a binder was discovered by Joseph Aspdin, who patented the formulation for what came to be known as *Portland cement*, after the extremely durable English Portland limestone. Portland cement was “harder, stronger, much more adhesive, and cured much more quickly than the ordinary lime mortar to which [the Romans] were accustomed.”³ Despite this discovery, which made concrete competitive with other building materials in terms of strength and durability, stone and brick remained the favored architectural building materials throughout the nineteenth century. As a result, concrete’s primary use in the nineteenth century was in industrial buildings and infrastructural projects.

Nevertheless, because concrete had the potential to “be cheaper than traditional masonry construction” and to be used as a “fireproofing” material for the increasing use of iron in building construction, there was a sustained interest in its development.⁴ While much experimentation and testing occurred in Europe in the mid-nineteenth century, vital to the assertion of concrete’s structural and economic advantages was the development of reinforced concrete at the end of the nineteenth century, largely due to important experimentation in the United States. Through his investigations between 1871 and 1872, William E. Ward demonstrated that the combination of iron and concrete would result in a composite assembly with improved strength. He also recognized that placing the iron near the bottom of a concrete beam would effectively increase the tensile capacity.⁵ Thaddeus Hyatt confirmed that the thermal coefficients of expansion and contraction for iron and

³ Edward Allen and Joseph Iano, *Fundamentals of Building Construction: Materials and Methods* (Hoboken, NJ: John Wiley & Sons, 2009), 516.

⁴ Bill Addis and Michael Bussell, “Key Developments in the History of Concrete Construction” in *Concrete Building Pathology*, ed. Susan Macdonald (Oxford: Blackwell Science Ltd, 2003), 18.

⁵ Collins, *Concrete*, 57.

concrete are the same, demonstrating the safety of this composite material in fires.⁶ Ernest Leslie Ransome, unlike his contemporaries, actually tried to exploit RC in America, despite a growing preference for iron and steel construction.⁷ In France, Francois Hennebique made an essential contribution to the development of RC when his patent for reinforced concrete in 1892 substituted steel for iron reinforcement.⁸ By the beginning of the twentieth century, textbooks on reinforced concrete were in circulation, making the material's properties and methods of production accessible and enabling continued experimentation with this material. Despite these advancements in RC technology and the advantages it offered, the acceptance of RC as an architectural material was not yet complete.

OBSTACLES TO ARCHITECTURAL USE OF REINFORCED CONCRETE

In the United States, there were numerous barriers to the architectural use of reinforced concrete. Because the U.S. did not have an established domestic cement industry until the end of the nineteenth century, the high cost of importing cement from Europe made the use of concrete less economical than other building materials, like steel.⁹ Cast-in-place reinforced concrete was also an entirely new type of material with no "handicraft tradition to guide practitioners," and although the actual placement of concrete did not rely on skilled labor, the fabrication and erection of the formwork necessary for cast-in-place concrete required an immense amount of craft labor.¹⁰ This necessity for skilled labor for RC construction did not conform to America's industrial principle: the drive to remove skilled labor from the construction site to increase efficiency and decrease cost. Instead, as

⁶ Ibid., 59.

⁷ Ibid., 61.

⁸ Ibid., 65.

⁹ Morris, *Precast Concrete in Architecture*, 79.

¹⁰ Donald Friedman, *Historical Building Construction: Design, Materials, and Technology*, (New York, NY: W.W. Norton & Company, Inc., 2010), 133.

the U.S. worked on the challenge of designing and constructing taller buildings, iron, and later steel, became the primary material used in this architecture because of its availability and the ability to factory-produce standardized members. Thus, steel became the preferred structural building material in America's building industry and "established a virtually impregnable ascendancy."¹¹ Even as other countries realized concrete's potential for fireproofing steel construction, America relied on its established method of using terra cotta slabs.¹²

The most significant barrier to concrete's architectural use in the United States, however, was its appearance. Stone, brick, and wood remained the primary architectural building materials, and concrete's aesthetic could not compete with the familiar and engrained aesthetic of these materials, as well as with their natural abundance at the end of the nineteenth century. As a result, although the establishment of a domestic cement industry in the latter part of the nineteenth century helped to enhance the economy of concrete construction in the U.S., RC continued to be relegated to industrial and infrastructural projects. In order to make RC more competitive with steel, the American Concrete Institute was established in 1904 to disseminate information about concrete and publish standards and manuals.¹³ In 1916, the Portland Cement Association was also founded to promote the use and quality of cement and concrete in America's building industry.¹⁴

As reinforced concrete became more established as a building material in the U.S., and the structural and economic advantages could no longer be ignored, architects began experimenting with concrete as an architectural material. In the U.S., initially, the

¹¹ Collins, *Concrete*, 86.

¹² *Ibid.*, 56.

¹³ Friedman, *Historical Building Construction*, 132.

¹⁴ "About PCA," PCA, last accessed 10 March 2016, <http://www.cement.org/>.

architectural use of concrete generally consisted of casting concrete to imitate traditional masonry materials, as seen in the production of cast stone. RC also began to be used in architecture as a structural material, although it was typically covered with veneers of more conventional materials, such as stone and brick. European architects, such as Auguste Perret, made significant contributions to the expression of concrete as its own architectural material in the early twentieth-century, although even these examples were fairly isolated. In the United States, “the most strikingly rational attempt to exploit both the structural and aesthetic values of concrete was made in 1905, when the Blenheim building was added to the Marlborough-Blenheim Hotel in Atlantic City, NJ.”¹⁵ Designed by architects Price and McLanahan of Philadelphia, the Blenheim building was the largest reinforced concrete building in the U.S. at the time and employed a concrete facade with terracotta details to avoid “sham” coverings and express the concrete itself [Figure 1].

¹⁵ Collins, *Concrete*, 87.



Figure 1. Detail of the concrete façade of the Blenheim building of the Marlborough-Blenheim Hotel in Atlantic City, NJ (1905).¹⁶

Determining how to express concrete as an architectural material continued to be a challenge into the twentieth century. In Europe, it was only after World War I and the maturation of the modern architectural style, which promoted the architectural expression of concrete as its own material, that concrete became a primary architectural material. In the United States, the transition to RC as a primary architectural material did not occur until after World War II.

¹⁶ Photo courtesy of: Collins, *Concrete*, Plate 23.

THE PREDECESSORS OF ARCHITECTURAL PRECAST WALL PANELS

By the end of the nineteenth century in the United States, the industrial production of precast concrete building elements, whether architectural or structural, was recognized to be one strategy to make concrete a more competitive building material, for the precasting process facilitated standardization and more closely aligned with America's industrial principle. Two important predecessors of architectural precast wall panels were cast stone and concrete masonry units (CMU). Although both were developed in the second half of the nineteenth century and were products of precasting, the two materials served distinct functions and contributed differently to the development of architectural precast wall panels.

Cast stone was developed in the second half of the nineteenth century with the establishment of the domestic cement industry and was a successful attempt to make the use of concrete in architecture acceptable—by casting it to imitate natural stone. To achieve this imitation, the concrete mix was designed to imitate the color, texture, and even veining of stone, and the concrete was then cast into custom molds. Cast stone had distinct advantages over natural stone, including the ability to be molded to the shapes required by the design and, through the use of reinforcement, to create long, load-bearing spans.¹⁷ The production of cast stone as veneer, block, and ornament also catered to the style of the time, the City Beautiful movement, which called for large Neo-Classical columns and ornamentation [Figure 2].¹⁸

¹⁷ Graham True, *Decorative and Innovative Use of Concrete* (Scotland, UK: Whittles Publishing, 2012), 56; Wyatt B. Brummitt, "Cast Stone," *American Builder* (1 June 1928): 97.

¹⁸ *Ibid.*, 94.

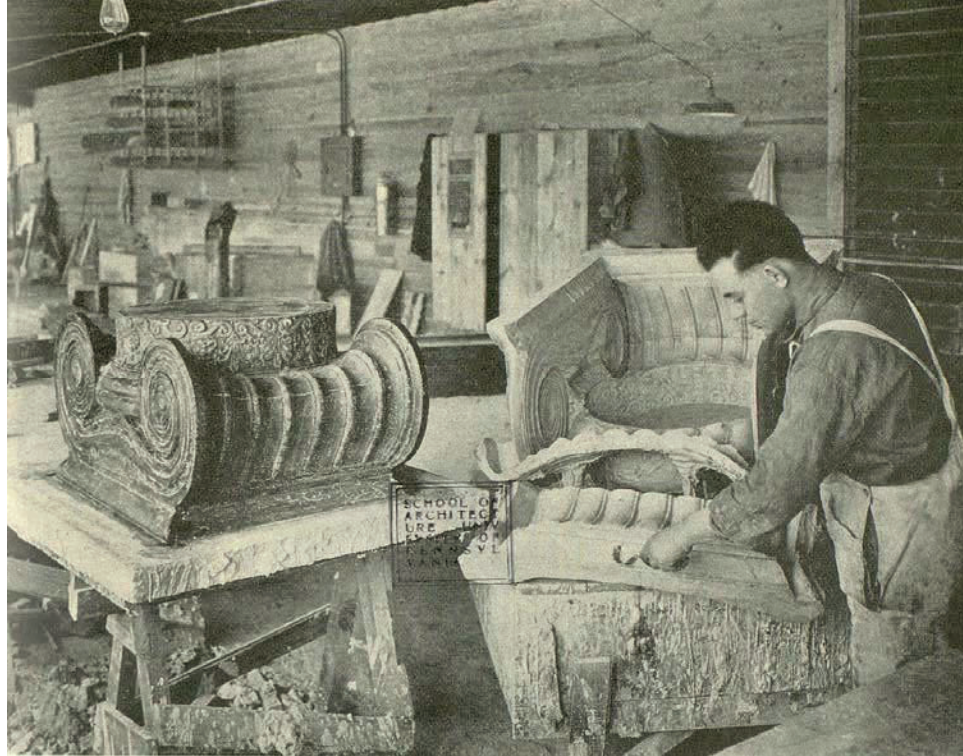

Figure 2. Cast stone column capitals.¹⁹

Still, certain characteristics of cast stone would prevent its prolonged success. First and foremost, although cast stone was cast off-site, its casting was very specialized and required an immense amount of craft skill. The creation of the molds themselves required expert workmanship, and they were often not reused, which limited the efficiency of the production process.²⁰ Similarly, all castings were “made a little over-size so that they may be finished down to precisely the dimension required”; because such finishing required skilled carvers, this added to the amount of skilled labor involved in the production process.²¹ The curing process, while controlled and able to achieve a high level of quality, required at least two weeks before the cast stone had gained sufficient strength to be stripped from the mold,

¹⁹ Photo courtesy of: Brummitt, “Cast Stone,” 95.

²⁰ Brummitt, “Cast Stone,” 95.

²¹ *Ibid.*, 97.

which in turn created longer production cycles.²² Cast stone also conformed to traditional masonry construction, requiring skilled masons for its assembly, and, therefore, ignored the trend towards the separation of skin and structure beginning in the late nineteenth and early twentieth century.²³ The labor intensity and inefficiency of cast stone production led to the cast stone industry's decline during the Great Depression, as material production became more and more mechanized.²⁴ The understanding of surface finishes and aesthetic mix design, however, ultimately provided the foundational knowledge used in the expression of architectural precast wall panels.

Concurrently with the development of cast stone, concrete masonry units began to be manufactured. Unlike cast stone, CMU were generally cast without an expressive surface finish. Additionally, CMU were cast in quantity by machines into standardized sizes, although the mass production of CMU did not begin until the beginning of the twentieth century.²⁵ Before 1915, CMU were used mostly for foundation, basement, and partition walls, but after the first two decades of the twentieth century and the improved production of CMU, the popularity of this concrete technology grew.²⁶ One article claimed that the use of concrete masonry units and tile increased 670 percent between 1920 and 1923.²⁷ The popularity of CMU reflected the public's growing confidence in concrete as a material to be used in architecture, although the architectural expression of concrete was not solved by CMU: the surface was often stuccoed for both aesthetic reasons and to increase the water

²² Ibid.

²³ Adrienne B. Cowden and David P. Wessel, "Cast Stone" in *Twentieth Century Building Materials: History and Conservation* (Los Angeles, CA: Getty Conservation Institute, 2014), 57.

²⁴ Ibid.

²⁵ Pamela H. Simpson, Harry J. Hunderman, and Deborah Slaton, "Concrete Block" in *Twentieth Century Building Materials: History and Conservation* (Los Angeles, CA: Getty Conservation Institute, 2014), 47.

²⁶ Ibid.

²⁷ "Growing Use of Concrete Products: Concrete Masonry and Other Products are in Growing Demand for Strength, Beauty of Finish, and Fire Resistance," *American Builder* 37/3 (1 June 1924): 369.

resistance of the CMU.²⁸ Even so, a 1933 article advertising an “honestly modern” concrete house conveys efforts to express concrete as its own architectural material [Figure 3].²⁹

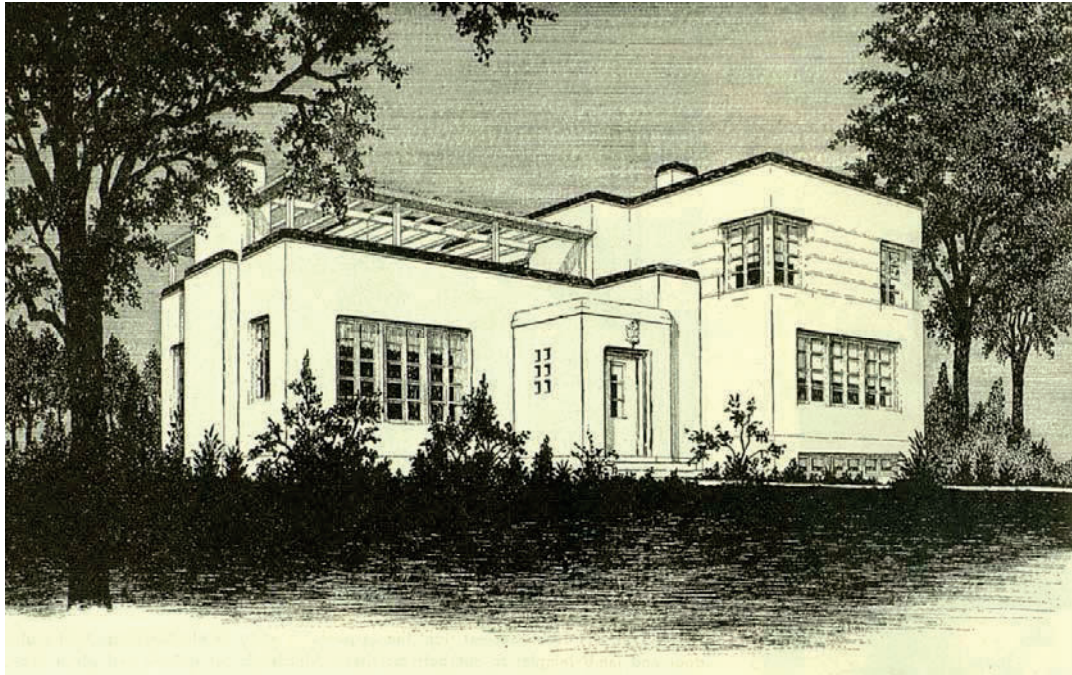

Figure 3. An “honestly modern” house composed of all concrete components, including unstuccoed exterior walls of concrete masonry units.³⁰

Notably, the use of concrete masonry units—which were inexpensive, could be produced more efficiently than cast stone, could be installed more quickly than traditional materials (such as fired clay masonry), were fireproof, and required little maintenance—exemplifies a key factor in concrete’s introduction into architectural settings: the promotion of its use by organizations such as Portland Cement Association in the economic

²⁸ Wyatt B. Brummitt, “Solve Building Problems with Concrete Masonry,” *American Builder* 44/3 (1 December 1927): 102.

²⁹ “An ‘Honestly Modern’ Concrete House: A Century of Progress in Concrete Building Shown in New Design by Wyatt B. Brummitt and Wal-Ward Harding for Portland Cement Association, Chicago,” *American Builder and Building Age* 55/3 (1 June 1933): 56.

³⁰ Photo courtesy of: “An ‘Honestly Modern’ Concrete House,” 56.

construction of houses. Numerous articles encouraged the use of CMU in the creation of economical houses and professed their beauty and serviceability.³¹ Because reinforced concrete was having difficulty competing with steel construction in commercial architectural settings, “the propaganda of the cement manufacturers in the United States tended to concentrate more on housing.”³² Thus, in addition to providing knowledge about mass and mechanized production, the CMU industry also profoundly affected the development of architectural precast wall panels by establishing a path for the architectural use of concrete. Still, because CMU also aligned with traditional load-bearing wall construction, its architectural use was inherently limited as construction moved towards the separation of skin and structure.

Thus, despite creating an architectural niche for concrete, the advantages of these two types of concrete technology were outweighed by the remaining obstacles to the widespread architectural use of concrete, including the continued preference for steel construction in the U.S. and concrete’s reliance on load-bearing wall construction. Nonetheless, the production of cast stone and CMU created the foundation for the production of architectural precast wall panels by providing important information about surface finishes and treatments and the casting process and by establishing a path for architectural precast wall panels’ use in the construction of houses.

NASCENT ARCHITECTURAL PRECAST WALL PANELS

The evolution of architectural precast wall panels stemmed from the need to satisfy two separate objectives that would ultimately make this concrete technology competitive

³¹ A.J.R. Curtis, “Most Popular of 500 Dwellings: A Successful Five Room House Plan and Some Reasons for Following It at Morgan Park, a Suburb of Duluth,” *American Builder* 34/5 (1 February 1923): 104.

³² Collins, *Concrete*, 89.

with other architectural building materials. The first objective was to make this concrete technology aesthetically pleasing. The second was to align it with the trends of the American building industry in the early twentieth century, which included reducing the amount of skilled labor needed on-site, enabling faster construction, separating the skin of buildings from their structure, and standardizing the components of construction. The knowledge of mix design and surface finishes and treatments honed by the cast stone industry contributed greatly to the first objective. Indeed, many cast stone manufacturers became precasters because of their understanding of the casting process, mix design, and surface finishes and techniques.³³ To achieve the second objective, however, precast wall panels deviated from cast stone and concrete masonry units.

Although precast panels were seen as early as 1875 when W.H. Lascelles patented his system for reinforced pre-cast construction, which included pre-cast slabs whose face could look like wall tiling, the development of precast panels really began in the second decade of the twentieth century.³⁴ Some of the pioneers included Ernest Leslie Ransome whose “Ransome Unit System,” patented in 1911, incorporated precast wall panels within a whole system of precast building components.³⁵ John E. Conzelman also attacked the question of how to make building construction more efficient through prefabrication between 1910 and 1916, during which time he took out more than fifty patents for his concrete “Unit System.”³⁶

Precast wall panels with an expressive architectural finish truly developed within the niche prepared by CMU to make economical and attractive housing. This was the first setting in which architectural precast wall panels could demonstrate the ease of their wall

³³ Cowden and Wessel, “Cast Stone,” 57.

³⁴ Collins, *Concrete*, 42.

³⁵ Morris, *Precast Concrete in Architecture*, 81.

³⁶ *Ibid.*

system construction, the advantages of precasting and the quality that could be achieved through this process, and the opportunity for individuality and beauty. A review of moderate-cost house construction methods and equipment in the August 1935 volume of *Architectural Record* advertises four separate precast wall systems. The Armostone System, developed by Concrete Housing Corporation, advertised a wall system composed of 1 in. thick precast panels three feet wide by story height that used cement mortar to seal the panels [Figure 4].³⁷ These panels, which were stiffened with vertical ribs, would be stuccoed on the exterior to achieve an appealing aesthetic.

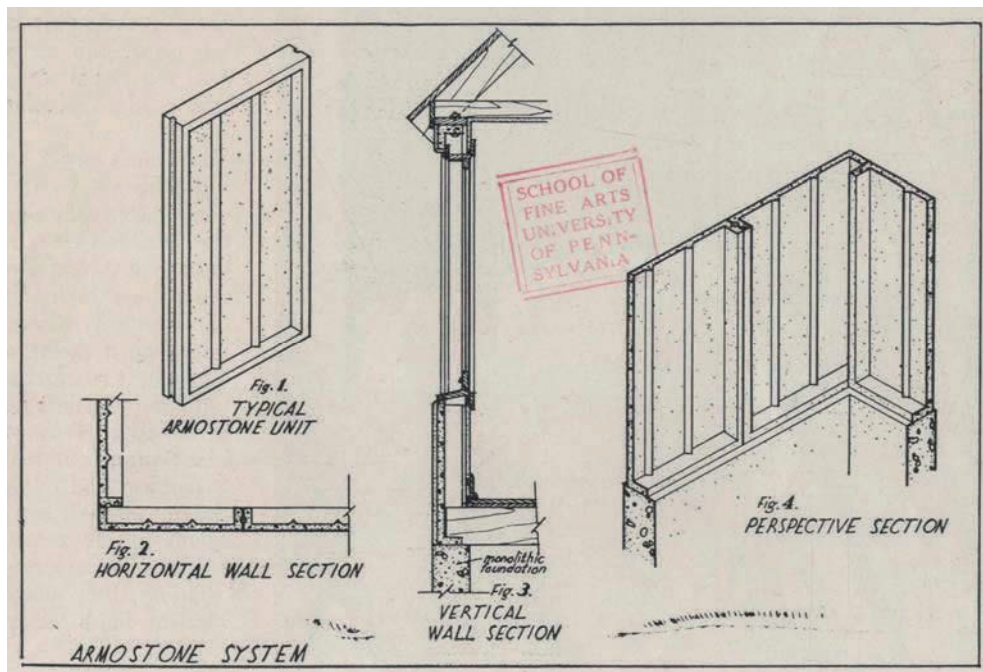

Figure 4. The Armostone System.³⁸

³⁷ "Moderate-Cost House Construction and Equipment," *Architectural Record* 78/2 (August 1935), 112.

³⁸ Photo courtesy of: "Moderate-Cost House Construction and Equipment," 112.

In contrast, the Lockstone System by Ernest H. Lockwood from Pasadena, California, advertised a hybrid wall system composed of smaller precast panels that formed the formwork for poured concrete walls. The precast panels, which were 1 ½ in. thick, 12 in. tall, and 36 in. wide, were advertised as being “attractively finished in the mould...need[ing] no further treatment” [Figure 5].³⁹

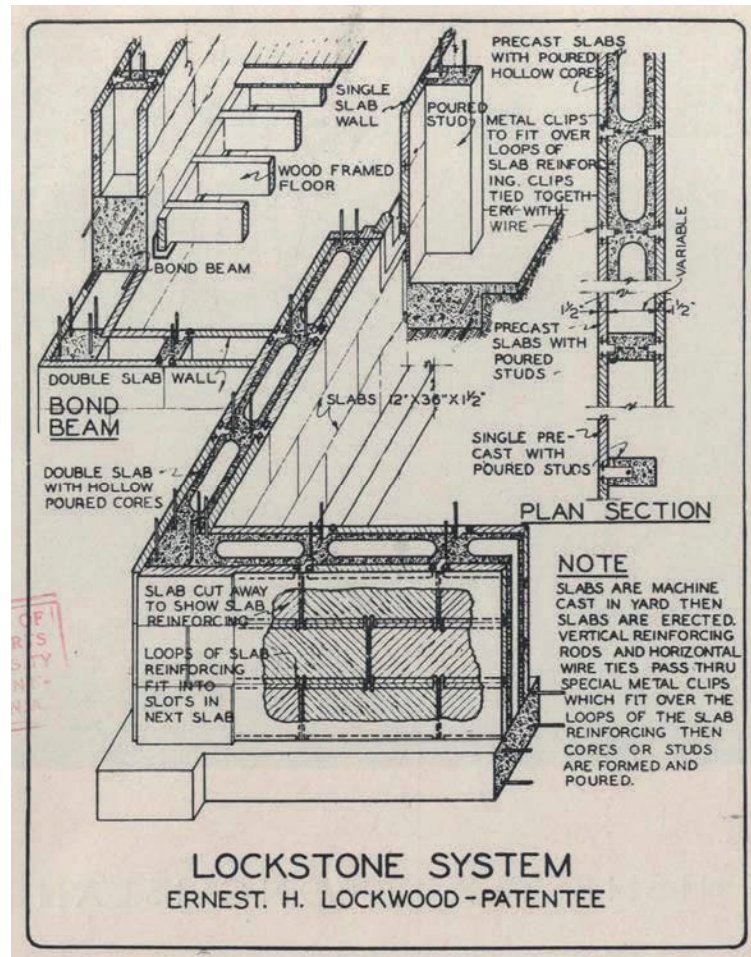

Figure 5. The Lockstone System.⁴⁰

³⁹ Ibid., 113.

⁴⁰ Photo courtesy of: “Moderate-Cost House Construction and Equipment,” 113.

John J. Earley's mosaic concrete precast panels were also advertised in this review. The mosaic concrete panels, which were 2 in. thick and approximately 9 ft. high and 4 to 10 ft. wide, were produced with a colorful exposed facing aggregate surface and required no additional treatment.⁴¹

The development of architectural precast panels in the U.S. owes much to the work of John J. Earley and the Earley Studio. Through their experimentation in the 1930s with exposed aggregate precast panels, known as MoSai, they discovered invaluable information about the precasting process and potential finishes and surface treatments.⁴² Like other precasters at the time and in light of the Great Depression, Earley explored the use of precast panels and professed their production as the best way to construct affordable, efficient, and beautiful housing.⁴³ He believed that through the use of concrete, and in particular precast wall panels, housing could be "within the reach of every family" in America and provide the security desperately needed after the Stock Market Crash of 1929.⁴⁴ The design of these houses also demonstrates Earley's recognition of the importance of minimizing the footprint of the building's walls to maximize the area of the interior space, a consideration that would become very important in the development of curtain wall systems.⁴⁵

Earley continued to explore the use of MoSai, improving the material's properties and production through testing. The creation of several prominent structures, such as the Edison Memorial Tower in New Jersey (1938) and the administration buildings at the David W. Taylor Model Testing Basin near Washington, DC (1938), led to the increased visibility of

⁴¹ Ibid., 111.

⁴² Earley's architectural precast panels were called MoSai, in reference to mosaics, to acknowledge the "artistic, craftsman-quality of this product" (Cellini, 3). By exposing the aggregate of the concrete mix, the surface of the MoSai panels were reminiscent to early Italian mosaics.

⁴³ John J. Earley, "Architectural Concrete Makes Prefabricated Houses Possible," *Journal of the American Concrete Institute* (May-June 1935): 514.

⁴⁴ Ibid.

⁴⁵ Ibid., 518.

this concrete technology.⁴⁶ Finally, with Earley's prominent role in the American Concrete Institute, of which he became president in 1939, research and publications about architectural precast wall panels and their production began to be pushed forward in the field.⁴⁷

Despite these promising beginnings, the earnest development of architectural precast panels and recognition of their potential would not be realized until after World War II and the dominance of the curtain wall system over traditional load-bearing construction. Such an environment would enable the rise in use of architectural precast wall panels.

WORLD WAR II AND CONCRETE

World War II was a pivotal moment for the architectural use of concrete in the United States. First, to support the war effort, America's preferred building material, steel, was rationed for general use. The rationing of steel finally justified the serious and sustained consideration of concrete in architectural settings, and, in particular, the use of precast structural frame components.⁴⁸ Furthermore, due to the war, the number of skilled construction trades available to build with traditional materials, such as stone and brick, was limited.⁴⁹ Without this skilled labor, the less skilled assembly of precast concrete systems, including architectural precast wall panels, became appealing and economical.

Second, with the coming of World War II, many European architects fled the Continent and immigrated to America. These architects believed in and designed according

⁴⁶ Sidney Freedman, "Architectural Precast Concrete" in *Twentieth Century Building Materials: History and Conservation*. (Los Angeles, CA: Getty Conservation Institute, 2014), 77.

⁴⁷ Jenna Cellini, "The Development of Precast Exposed Aggregate Concrete Cladding: The Legacy of John J. Earley and the Implications for Preservation Philosophy," University of Pennsylvania Master's Thesis (2008), 69.

⁴⁸ Morris, *Precast Concrete in Architecture*, 93.

⁴⁹ Michael A. Tomlan, "Building Modern America: An Era of Standardization and Experimentation" in *Twentieth-century Building Materials: History and Conservation* (LA, CA: Getty Conservation Institute, 2014), 8.

to the new style of modern architecture that accommodated concrete and its appearance. The philosophy of modern architecture had matured after World War I in Europe and proposed a break with the past through the rejection of ornamentation, utilization of simple, rational forms, and reliance on objective problem solving.⁵⁰ Concrete fit nicely into this philosophy and became a defining material of the style, especially given the promotion of concrete by the prominent architect Le Corbusier. Le Corbusier demonstrated concrete's place in the new style, and consequently in architecture, by recognizing the "remarkable adaptability of concrete...with its sculptural and structural potential."⁵¹

Although the translation of the mature modern style to the United States provided a place for architectural reinforced concrete, the contributions of one important American architect cannot be ignored. Through his experimentation with reinforced concrete, Frank Lloyd Wright helped to introduce both modern materials and modern architectural ideas to the U.S. With works such as the Johnson Wax Administration (Racine, WI, 1936-1939) and Falling Water (Bear, PA, 1936), Wright illustrated the potential of reinforced concrete in American architecture.⁵² Moreover, Wright helped to reveal the aesthetic potential of exposing specially selected aggregate on concrete's surface, a technique that would "become by far the most widely used precast concrete surface finish."⁵³ Despite such strides, however, Frank Lloyd Wright alone did not instigate the widespread architectural use of concrete.

Instead, the influx of European architects into the United States fundamentally changed the architectural perspective on concrete. Many of these architects, including numerous German architects such as Walter Gropius, Ludwig Mies van der Rohe, and

⁵⁰ Mark Gelernter, *A History of American Architecture: Buildings in Their Cultural and Technological Context* (Hanover: University Press of New England, 1999), 237.

⁵¹ "Le Corbusier's Love for Concrete," *Concrete International* (1 March 2015): 38.

⁵² Kenneth Frampton, *Modern Architecture: A Critical History* (London: Thames and Hudson Ltd., 1980), 188.

⁵³ Morris, *Precast Concrete in Architecture*, 89.

Marcel Breuer, filled leadership positions in American design schools and “shaped the future of American architecture at its source, in the education of the next generation of architects.”⁵⁴

CONCLUSION

Thus, by the end of World War II, the architectural use of concrete began to flourish in the United States. Between 1946 and 1969, the U.S. experienced the longest continuous period of growth in the nation’s history, and during that period, reinforced concrete became the material of choice.⁵⁵ Although architectural precast wall panels would greatly contribute to this shift, essential to the widespread use of architectural precast panels was the change in building assemblies from load-bearing walls to the separation of a building’s skin from its structure.

⁵⁴ Ibid.

⁵⁵ Tomlan, “Building Modern America,” 9.

CHAPTER 3: APPLICATION OF ARCHITECTURAL PRECAST WALL PANELS IN MID-CENTURY ARCHITECTURE

DEVELOPMENT OF THE CURTAIN WALL SYSTEM

Beginning in the late nineteenth century, wall assemblies began to change: the skin of the building was separated from its structure. This separation led to the emergence of the curtain wall system—a wall assembly that separates the exterior from the interior space of the building and supports nothing but itself.⁵⁶ The transition towards curtain walls partly arose from the challenge of creating taller buildings while simultaneously maximizing rentable floor space. For example, the Monadnock Building built in Chicago in 1893 met the requirements of a taller building, but its 6 ft. deep bearing walls greatly reduced the amount of rentable space per the footprint of the building.⁵⁷ As steel and concrete frames developed for the gravity loads previously borne by load-bearing walls, the wall could be reduced to a thin skin that supported itself and resisted weather and lateral loads such as wind. This separation encouraged both greater interior flexibility and the rationalization of the building process by separating the erection of the structure from the installation of the building's skin.⁵⁸

Pietro Belluschi's Equitable Savings and Loan Building in Portland Oregon (1948) is often credited as being the pioneer building in curtain wall construction.⁵⁹ Like most early curtain walls, this curtain wall was comprised of metal window framing and glazing. Ludwig Mies van der Rohe, a leader in mid-century modern architecture, spearheaded the use of

⁵⁶ William Dudley Hunt, *The Contemporary Curtain Wall* (New York: F.W. Dodge Corp, 1958), 1.

⁵⁷ *Ibid.*, 5.

⁵⁸ Theodore H.M. Prudon, FAIA, *Preservation of Modern Architecture* (Hoboken, NJ: John Wiley & Sons, Inc., 2008), 111.

⁵⁹ David Thomas Yeomans, "The Arrival of the Curtain Wall," *Preserving the Recent Past*, 3-140.

curtain walls and greatly contributed to the evolution of this technology.⁶⁰ His steel and glass curtain wall design for 860-880 Lake Shore Drive Apartments in Chicago (1948-1951) demonstrates his early commitment to this technology, and his subsequent designs for other metal and glass curtain walls for buildings like the Esplanade Apartment Buildings in Chicago (1953-1956) and the Seagram Building in New York City (1954-1958) convey the prominent place curtain wall technology had in modern architecture [Figure 6 and 7]. Given this prominence, in order for concrete to stay competitive with metal and glass curtain walls, a form of concrete would have to be developed that could align with this type of building assembly.

⁶⁰ *Mellon Hall Historic Structure Report* (University of Pittsburgh: Architectural Studies Program Documentation and Conservation Studio, Spring 2013), 65.



Figure 6. Lake Shore Drive Apartments by Mies van der Rohe (Chicago, 1948-1951).⁶¹

⁶¹ Photo courtesy of: Werner Blaser, *Mies van der Rohe: Lake Shore Drive Apartments* (Basel, Switzerland: Birkhäuser – Publishers for Architecture, 1999), 41.

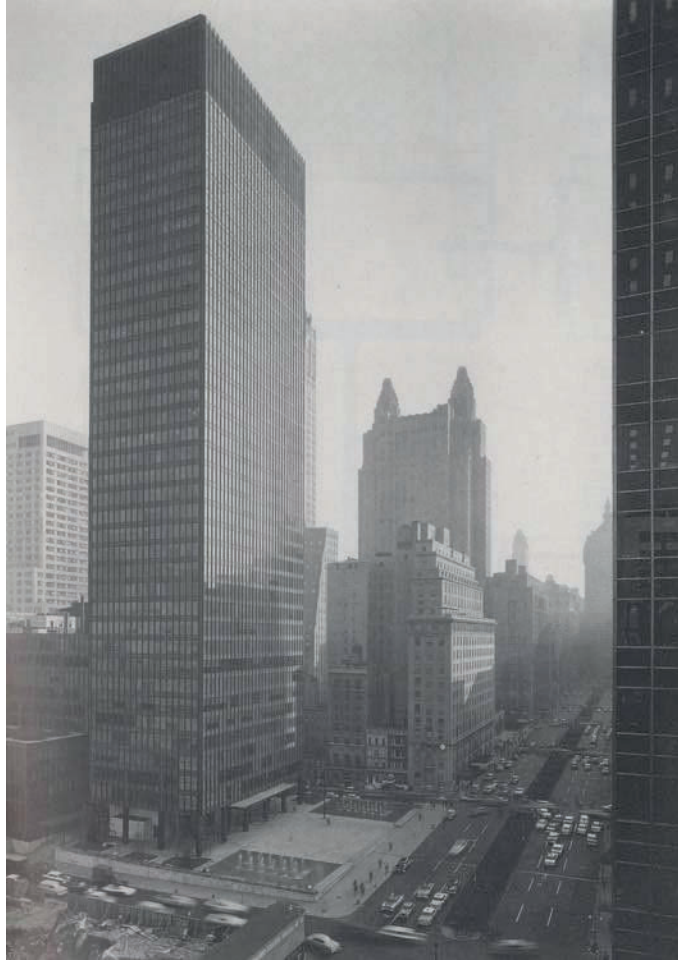

Figure 7. The Seagram Building by Mies van der Rohe (New York City, 1954-1958).⁶²

Architectural precast wall panels had numerous advantages over cast stone, concrete masonry units, and even cast-in-place concrete. First, the precasting process of architectural precast wall panels achieved a high level of quality because of the controlled production environment, which enabled better surface finishes and/or treatments. The process was also far more efficient: the table or floor height at which the panels were cast both simplified and accelerated the casting operation, there was minimum formwork because it was reused, and reinforcement could be placed more easily than in cast-in-place

⁶² Photo courtesy of: Werner Blaser, *Mies van der Rohe* (Basel, Switzerland: Birkhäuser - Verlag für Architektur, 1997), 163.

concrete.⁶³ Additionally, through the introduction of early strength concrete, the curing time could be greatly reduced and twenty-four-hour production cycles were not uncommon, unlike the two-week-long curing time for cast stone.⁶⁴ Most importantly, those other forms of concrete relied on load-bearing wall systems while the thin cross-section and large area of architectural precast wall panels could be readily adapted to the curtain wall system.

Despite these advantages over other concrete technologies, architectural precast wall panels had important obstacles to overcome before they could effectively compete with metal and glass curtain walls. Initially, their use in curtain wall systems was limited by the materials-handling equipment available: because of the lack of mobile cranes and other efficient materials-handling equipment, construction of precast concrete curtain walls was slower than the construction of metal and glass curtain walls, which often could be assembled from within the building.⁶⁵ The production of metal and glass curtain wall systems also exploited “the seemingly pre-emptive potential of precision, mass-production ‘machine-age’ technology,” fitting neatly into the United States’ industrialization of building construction.⁶⁶ In the years after World War II, the issue of more efficient handling equipment was resolved through the introduction of rubber-tired mobile cranes and the introduction of lightweight aggregate concrete mixes, which made panels lighter.⁶⁷ Additionally, improved methods in production helped to enable the mass-production and standardization of architectural precast wall panels. Thus, through the development of architectural precast panels, the concrete industry provided a concrete technology that could compete with metal and glass curtain walls in its ability to be mass-produced, but also

⁶³ “Precast Concrete: Wall Panels.” Portland Cement Association (October 1954), 10.

⁶⁴ Ibid.

⁶⁵ Freedman, “Architectural Precast Concrete,” 78; Hunt, *The Contemporary Curtain Wall*, 6.

⁶⁶ Morris, *Precast Concrete in Architecture*, 96.

⁶⁷ Ibid., 95.

in its “exceptional resistance to wind, rain, and fire” and the variety of forms and finishes that could be achieved with precast technology.⁶⁸

FLOURISHING OF ARCHITECTURAL PRECAST WALL PANELS

The popularity of architectural precast panels increased in the 1950s and 1960s due to better handling/erecting equipment, improved methods of production, and the continued development of new techniques and materials. One innovation that improved production was the utilization of Shokbeton (or shocked concrete), which was a new casting method that enabled the consolidation of no-slump concrete mixes through repetitive and fast raising and dropping of the form.⁶⁹ Improvements in casting technology and handling equipment also made larger panels possible, which made construction faster and required fewer joints and connections. The development of the window-type mullion wall panel which introduced glazing into architectural precast wall panels, made this concrete technology even more competitive with metal and glass curtain walls [Figure 8].⁷⁰ Similarly, the development of sandwich panels, which are precast panels consisting of two outer faces of concrete that sandwich a core of insulative material, provided a type of precast panel that addressed growing concerns for heating and air-conditioning costs.⁷¹ Also important was the realization of the “structural economies to be gained from utilizing the primary structural potential of precast concrete units,” which further maximized the rentable floor

⁶⁸ Ibid., 96.

⁶⁹ T.W. Hunt, “Precast Concrete Wall Panels: Historical Review,” *Symposium on Precast Concrete Wall Panels*, ACI Publication SP-11 (1965): 13.

⁷⁰ Victor Leabu, “Precast Concrete Wall Panels: Design Trends and Standards.” *Symposium on Precast Concrete Wall Panels*, ACI Publication SP-11 (1965), 37.

⁷¹ D.W. Pfeifer and J.A. Hanson, “Precast Concrete Wall Panels: Flexural Stiffness of Sandwich Panels,” *Symposium on Precast Concrete Wall Panels*, ACI Publication SP-11 (1965): 67.

space by eliminating the need for an entirely separate structural frame while retaining a thin wall section.⁷²

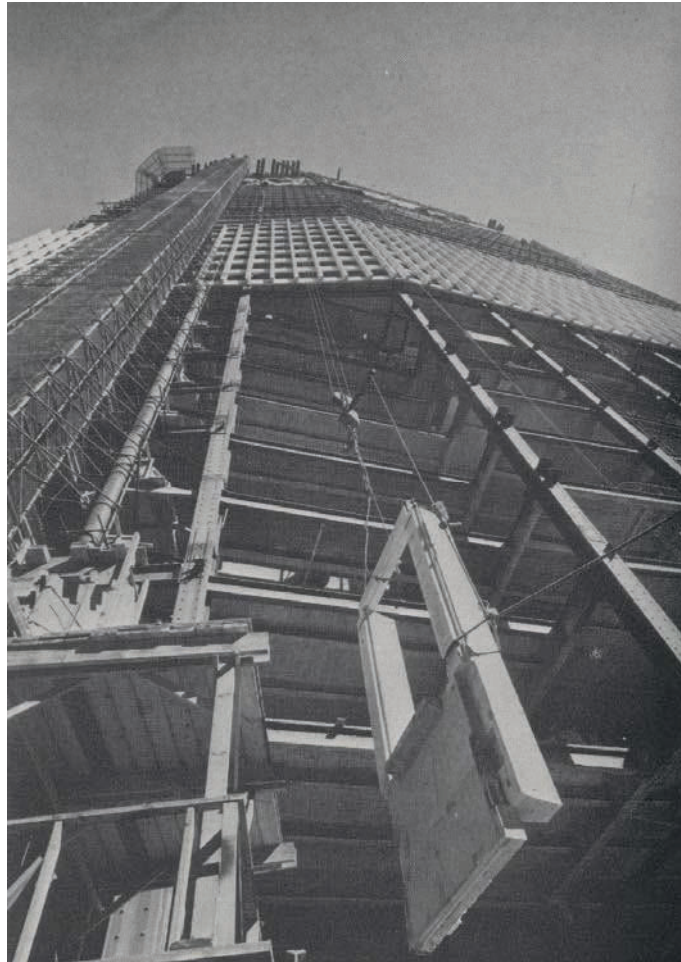

Figure 8. A window-type mullion wall panel is here being hoisted into its place on the Pan American Building in NYC (1962). Window-type mullion wall panels integrated glazing into the precast panel, making architectural precast wall panels more competitive with metal and glass curtain walls.⁷³

⁷² Morris, *Precast Concrete in Architecture*, 156.

⁷³ Photo courtesy of: Morris, *Precast Concrete in Architecture*, 162.

The most significant reason for architectural precast panels' rise in popularity, however, was the variety of surface textures and patterns and exterior designs that could be acquired, a range that generally could not be achieved as economically in other materials.⁷⁴ Although nearly all surface finishes and treatments that were ultimately used in the 1950s and 1960s were established by the early twentieth century, the improved precasting process provided enough control to optimize their implementation.⁷⁵ Similarly, as form technology advanced and incorporated different materials, such as steel and fiberglass reinforced plastics, the variety of shapes that could be accomplished with architectural precast panels was marketed as being "limited only by the imagination of the architect and designer."⁷⁶

Therefore, although the increased speed of construction and high quality of the product made architectural precast wall panels competitive with metal and glass curtain walls, it was the diversity in shapes, colors, and textures that made this concrete technology the preferred material for curtain walls.⁷⁷ To illustrate the range of aesthetics that could be achieved with architectural precast wall panels, as well as their adaptation to curtain wall assembly, the following sections present examples of their use in mid-century architecture.

MODERNIST ARCHITECTS AND ARCHITECTURAL PRECAST WALL PANELS

The first architecturally significant building to incorporate architectural precast wall panels was the Denver Hilton Hotel in Denver, Colorado [Figure 9]. Constructed in 1959 and designed by I.M. Pei & Partners, this building "represented the first fully

⁷⁴ Freedman, "Architectural Precast Concrete," 78.

⁷⁵ Morris, *Precast Concrete in Architecture*, 90

⁷⁶ Leabu, "Precast Concrete Wall Panels: Design Trends and Standards," 37.

⁷⁷ Freedman, "Architectural Precast Concrete," 78.

consistent use of concrete in the U.S.: a precast skin enclosing a concrete structure.”⁷⁸ Utilizing story-high panels, the design of the building worked to overcome some of the early aesthetic challenges precast wall panel systems presented, such as how to attractively incorporate the joints between the panels.⁷⁹ Aldo Cossutta, the chief architect of the Denver Hilton Hotel, decided to design “into the surface a grid with a pattern of deep reveals: a tracery of shadow lines engendering all the joints and relegating them to a lesser role.”⁸⁰ The concrete mix of the panels used sand and gravel sieved from the soil excavated on the site, and the surface of the panels was lightly etched with acid to expose the natural aggregate.⁸¹



Figure 9. The Denver Hilton Hotel designed by Aldo Cossutta in Denver, CO (1959).⁸²

⁷⁸ Aldo Cossutta “From Precast Concrete to Integral Architecture,” *Progressive Architecture* (October 1966): 196.

⁷⁹ Morris, *Precast Concrete in Architecture*, 160.

⁸⁰ Cossutta, “From Precast Concrete to Integral Architecture,” 198.

⁸¹ *Ibid.*, 196.

⁸² Photo courtesy of: “Sheraton Denver Downtown Hotel: I.M. Pei Tower,” Sheraton, last accessed 25 April 2016, <http://www.sheratondenverdowntown.com/im-pei-tower>.

Marcel Breuer also had a particular interest in precast technology. Breuer and Herbert Beckhard designed the Murray Lincoln Campus Center at the University of Massachusetts in Amherst, Massachusetts (1970), which consists of three different types of precast panels connected to a structural frame and exterior end walls of cast-in-place concrete [Figure 10].⁸³ The ten-story tower demonstrates the variety of shapes that can be achieved with architectural precast panels.

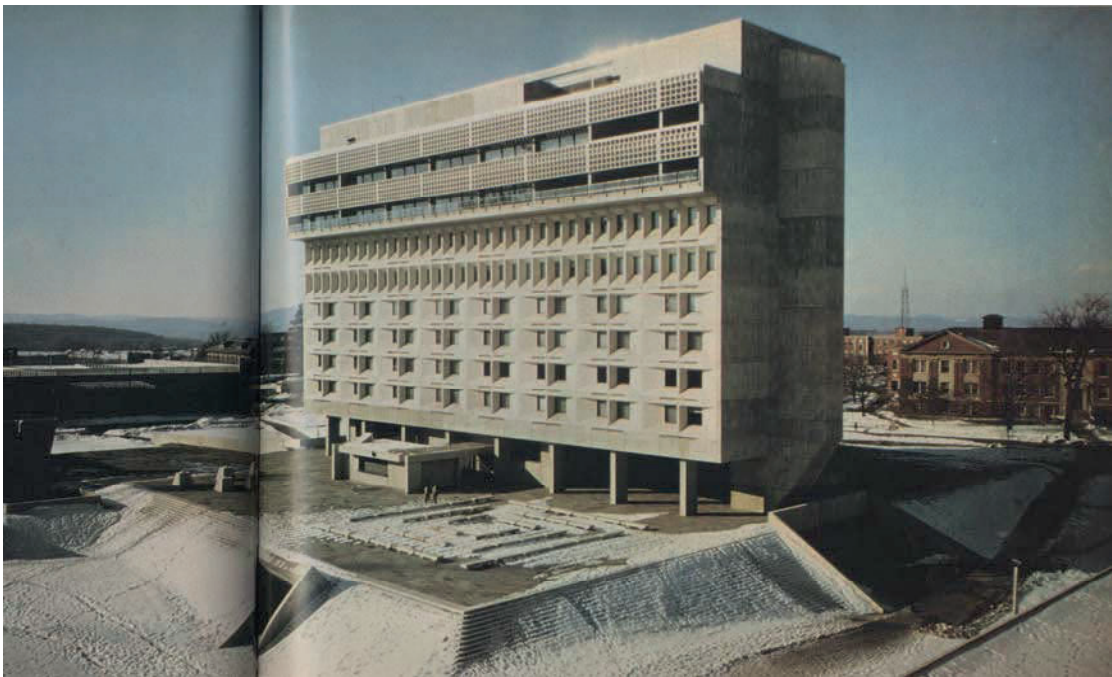

Figure 10. Marcel Breuer and Herbert Beckhard's Murray Lincoln Campus Center at the University of Massachusetts in Amherst, MA (1970) demonstrates on a single structure the variety of shapes that can be achieved with architectural precast wall panels.⁸⁴

⁸³ "Three Precast Buildings from the Office of Marcel Breuer and Associates," *Architectural Record* (March 1973): 118.

⁸⁴ Photo courtesy of: "Three Precast Buildings from the Office of Marcel Breuer and Associates," 118-119.

Walter Gropius, founder of the Bauhaus, and Pietro Belluschi, architect of the Equitable Building in Portland, Oregon, designed the Pan American Building in New York City [Figure 11].⁸⁵ Constructed in 1962, the fifty-seven-story tower is clad with 9,000 story-high precast concrete window units faced with exposed quartz aggregate.⁸⁶



Figure 11. The Pan American Building in New York City (1962), designed by Walter Gropius and Pietro Belluschi, is clad with 9,000 story-high precast window units.⁸⁷

⁸⁵ Christopher Gray, "Streetscapes / The MetLife Building, Originally the Pan Am Building; Critics Once Called It Ugly; Now They're Not Sure," *The New York Times* (7 October 2001), <http://www.nytimes.com/2001/10/07/realestate/streetscapes-metlife-building-originally-pan-am-building-critics-once-called-it.html?pagewanted=all>.

⁸⁶ Morris, *Precast Concrete in Architecture*, 161.

⁸⁷ Photo courtesy of: "Air Rights: Pan Am Building," The Pan Am Historical Foundation, last accessed 25 April 2016, <http://www.panam.org/the-jet-age/370-air-rights-the-pan-am-building-2>.

In Philadelphia, the architectural firm Geddes, Brecher, Qualls, and Cunningham explored the use of precast panels. One of their most famous structures, the Philadelphia Police Headquarters (1962), utilizes three-story tall structural precast panels [Figure 12].⁸⁸



Figure 12. The Philadelphia Police Headquarters (1962) is Geddes, Brecher, Qualls, and Cunningham's most famous structure, the exterior of which consists of three-story tall structural precast wall panels.⁸⁹

Geddes, Brecher, Qualls, and Cunningham also explored the use of architectural precast panels in their design for the Northeast Regional Library in Philadelphia (1962) [Figure 13]. The panels of this public library, which were attached to a structural cast-in-place concrete

⁸⁸ Morris, *Precast Concrete in Architecture*, 155.

⁸⁹ Photo courtesy of: Save the Roundhouse and found in Nicole Anderson, "Pending Sale of Philadelphia's Roundhouse Police Headquarters Spurs Campaign for Landmark Status," *The Architect Newspaper* (22 March 2013), <http://archpaper.com/2013/03/pending-sale-of-philadelphias-roundhouse-police-headquarters-spurs-campaign-for-landmark-status/>.

frame, are composed of gray cement with an aggregate of white quartz and “Riverdale” stone from New Jersey.⁹⁰ The panels were finished with a low-pressure sandblast to expose the aggregate, and a colorless silicone water repellent coating was applied to their exterior after installation.⁹¹



Figure 13. Geddes, Brecher, Qualls, and Cunningham’s design for the Northeast Regional Library in Philadelphia (1962) is clad with architectural precast wall panels, a detail of which is shown in this image.⁹²

⁹⁰ “Precast Panels on a Frame,” *Progressive Architecture* (September 1964): 157.

⁹¹ *Ibid.*

⁹² “Precast Panels on a Frame,” 156.

VARIETY OF BUILDINGS AND AESTHETICS

The use of architectural precast wall panels was easily adapted to a variety of building types. The Buffalo Evening News Building (1973), which is currently on DOCOMOMO's register of significant modern buildings, was designed by Edward Durell Stone and Associates. The large and weighty exposed aggregate precast wall panels, which were connected to a cast-in-place concrete structural frame, juxtapose the airiness of the roof, which appears to float in space above the precast panels and the deeply recessed windows designed in them [Figure 14].⁹³



Figure 14. The Buffalo Evening News Building, designed by Edward Durell Stone and Associates (1973), is clad with massive architectural precast panels.⁹⁴

⁹³ "The Buffalo Evening News Building," DOCOMOMO-US, last modified 3 May 2014, http://www.docomomo-us.org/register/fiche/buffalo_evening_news_building.

⁹⁴ Photo courtesy of: Robert M. Metz, Buffalo Evening News Photo Collection from 6 January 1973 found on "The Buffalo Evening News Building," DOCOMOMO-US, last accessed 25 April 2016, http://www.docomomo-us.org/register/fiche/buffalo_evening_news_building.

The Walters Art Museum addition in Baltimore, Maryland (1974), which was designed by Shepley, Bulfinch, Richardson, and Abbot of Boston and Meyer, Ayres, and Saint of Baltimore, was constructed to provide much needed gallery space for the Baltimore museum [Figure 15].⁹⁵ The primary elevations of the addition utilized precast panels as a brise soleil, which span the width of the elevations and are suspended several feet from the exterior wall of the building. The concrete mix of these panels compliments the stone of the original museum building, and the panels are finished on the street-facing side with striations to create an interesting texture, while the aggregate is exposed on the panel side facing the museum, which can be seen from the gallery spaces within.



Figure 15. The precast panels of the Walters Art Museum addition in Baltimore, MD, designed by Shepley, Bulfinch, Richardson, and Abbot of Boston and Meyer, Ayres, and Saint of Baltimore (1974), form a brise soleil (photo by author).

⁹⁵ "From Art Gallery to Art Museum," The Walters Art Museum, last accessed 9 February 2016, <http://thewalters.org/about/history/gallery.aspx>.

Numerous skyscrapers were constructed with architectural precast wall panels. In New York City, the Banker Trust Building (1962), which was designed by Emory Roth and Sons, was constructed with story-high window wall units [Figure 16].⁹⁶ These panels were composed of a white quartz aggregate in a white cement matrix and were finished to expose the aggregate.⁹⁷

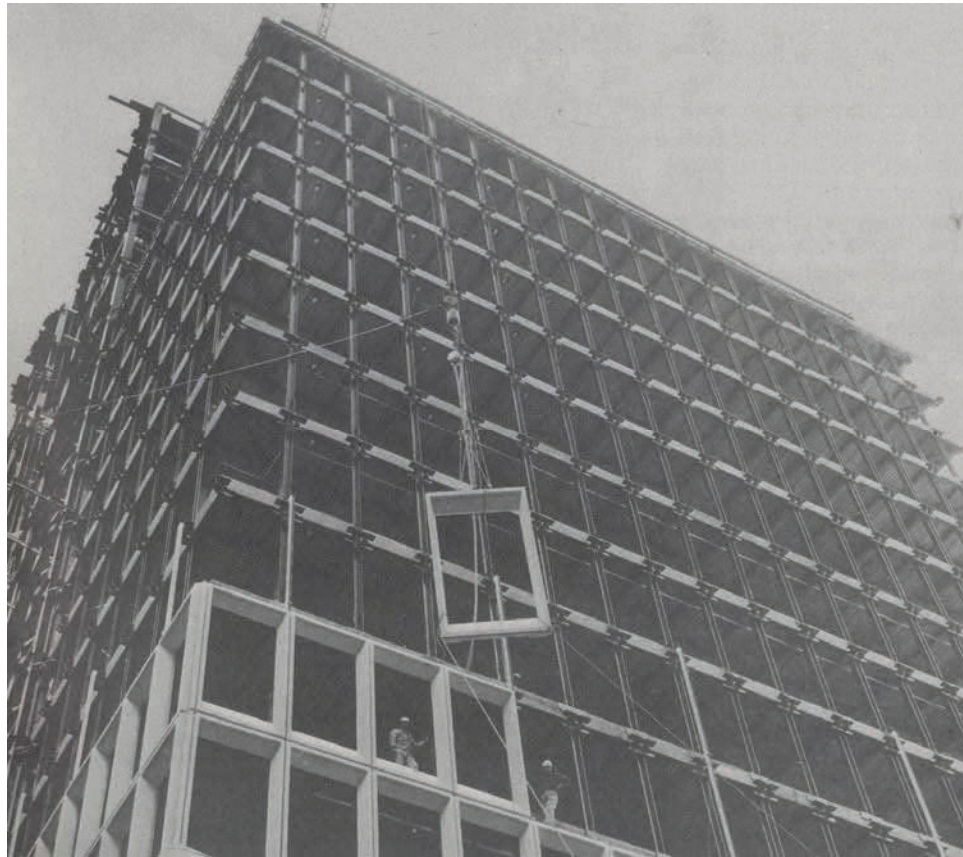

*Figure 16. One of the story-high window units is seen here being hoisted onto the elevation of the Banker Trust Building in New York City, designed by Emory Roth and Sons 1962).*⁹⁸

⁹⁶ Morris, *Precast Concrete in Architecture*, 161.

⁹⁷ Hunt, "Precast Concrete Wall Panels: Historical Review," 11.

⁹⁸ Photo courtesy of: Morris, *Precast Concrete in Architecture*, 161.

In Chicago, the Water Tower Inn (1961), which was designed by Hausner and Macsai, illustrates the texture that could be achieved with architectural precast panels: the vertically staggered story-high window boxes create a distinctive elevational pattern [Figure 17].⁹⁹

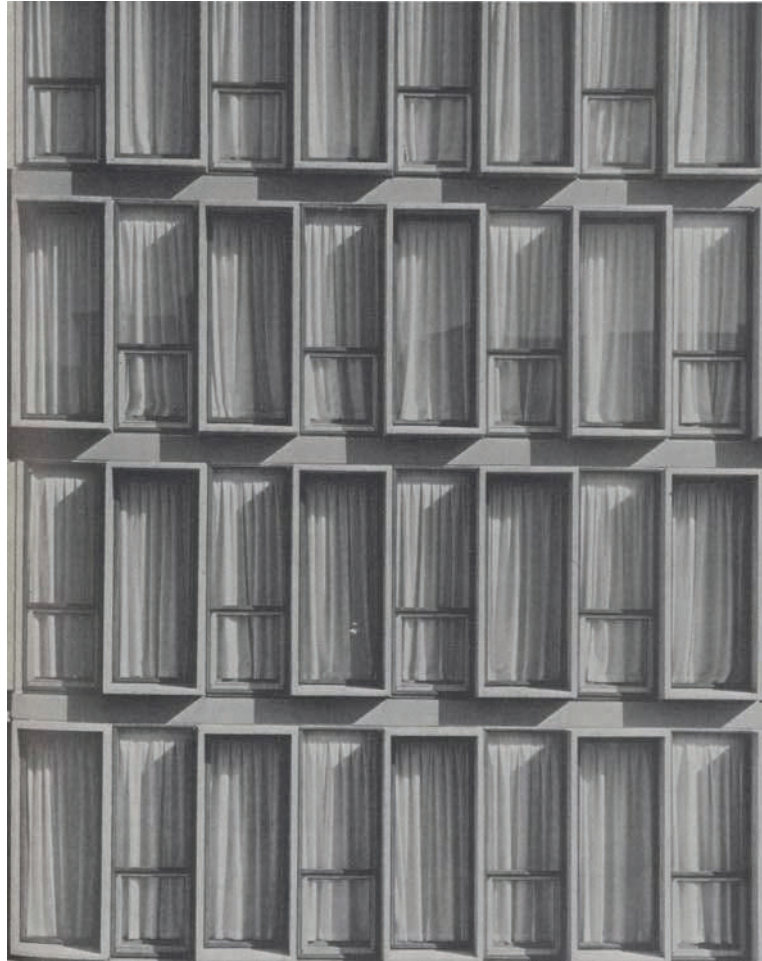

Figure 17. The window units cladding the Water Tower Inn in Chicago, designed by Hausner and Macsai (1961), create a dynamic elevation pattern.¹⁰⁰

⁹⁹ Morris, *Precast Concrete in Architecture*, 163.

¹⁰⁰ Photo courtesy of: Morris, *Precast Concrete Architecture*, 163.

In San Francisco, architectural precast panels form the undersill of the ribbon windows on the International Building (1961), designed by Anshen and Allen [Figure 18].¹⁰¹ These panels were designed with a re-entrant corner surface, which creates interesting shadows and depth on the building's elevations.



Figure 18. The elevations of the International Building in San Francisco, by Anshen and Allen (1961), are defined by alternating layers of glazing and precast undersills, whose reentrant corner design creates interesting shadows and depth.¹⁰²

¹⁰¹ Ibid., 164.

¹⁰² Photo courtesy of: Thomas found on "International Building," Archikey.com, last accessed 25 April 2016, <http://archikey.com/building/read/2799/International-Building/663/>.

Schools, universities, and libraries also utilized architectural precast panels. Designed by the firm of Holabird & Root & Burgee, the McGaw Memorial Hall at Northwestern University in Evanston, Illinois (1953), is an early example of the use of architectural precast wall panels in a university setting [Figure 19].¹⁰³ The panels, which were clamped to a steel frame, are solid architectural precast wall panels 8" thick and 8'4" square in area.¹⁰⁴ The Oak Park High School in Laurel, Mississippi (c. 1965, architect unknown), conveys the growing use of color in architectural precast panels [Figure 20].¹⁰⁵ At Temple University in Philadelphia, Nolen & Swinburne's Samuel Paley Library (1966) is clad with story-high exposed aggregate panels [Figure 21].¹⁰⁶ Finally, the cylindrical auditorium of the Miami Beach Public Library in Florida, designed by Herbert A. Mathes (1962), demonstrates the textures and patterns that can be achieved using sculptured sand that is translated to the precast panel surface during casting [Figure 22].¹⁰⁷ The end result is a dynamic exterior that could not be achieved in any other material.

¹⁰³ "McGaw Hall," University Archives: Northwestern Architecture, last accessed 17 April 2016, <http://digital.library.northwestern.edu/architecture/building.php?bid=12>.

¹⁰⁴ "Precast Concrete: Wall Panels," PCA, 9.

¹⁰⁵ Hunt, "Precast Concrete Wall Panels: Historical Review," 8.

¹⁰⁶ Amelia Brust, "Board Approval Signals New Chapter for Library," *The Temple News* (19 March 2012), <http://temple-news.com/news/board-approval-signals-new-chapter-for-library/>.

¹⁰⁷ David Rifkind, "A Story Told in Fragments," Miami's Community Newspapers, last accessed 1 April 2016, <http://communitynewspapers.com/miami-beach-featured/a-story-told-in-fragments/>; Hunt, "Precast Concrete Wall Panels: Historical Review," 1.

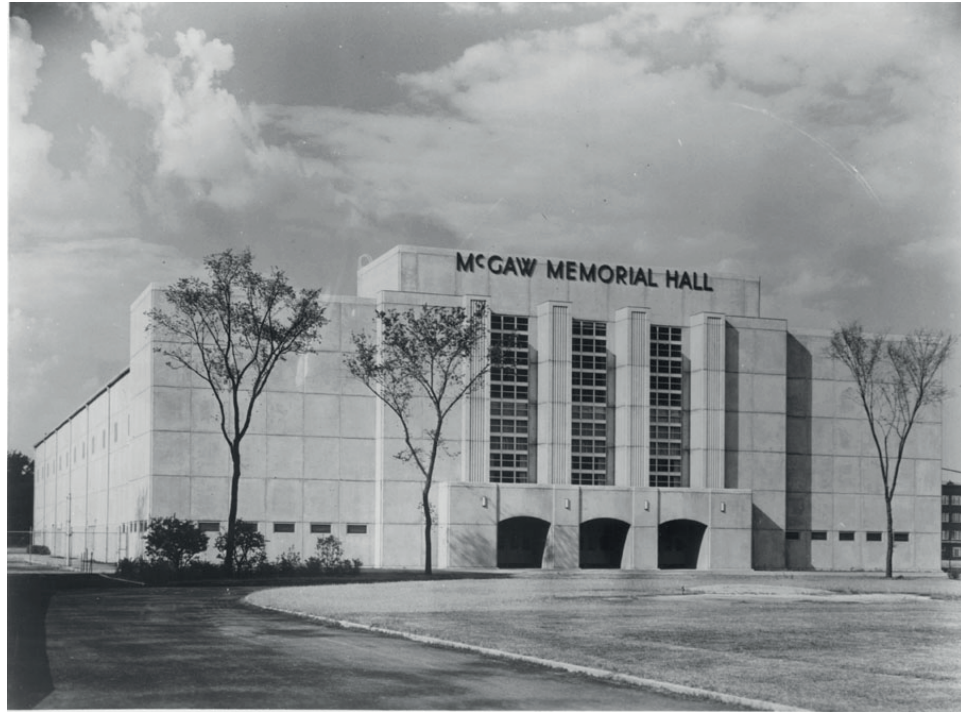

Figure 19. McGaw Memorial Hall by Holabird & Root & Burgee (1953) is an early example of solid precast wall panels.¹⁰⁸



Figure 20. The Oak Park High School utilizes colored architectural precast wall panels on the school's façade.¹⁰⁹

¹⁰⁸ Photo courtesy of: "McGaw Hall," University Archives: Northwestern Architecture," last accessed 25 April 2016, <http://digital.library.northwestern.edu/architecture/image.php?iid=124&all=123,129,128,130,124,126,127,121,122,125>.



Figure 21. The Samuel Paley Library, designed by Nolen & Swinburne (1966), is clad with solid exposed aggregate panels.¹¹⁰

¹⁰⁹ Hunt, "Precast Concrete Wall Panels: Historical Review," 8.

¹¹⁰ Photo courtesy of: "Paley Library, Temple University," Preservation Alliance, last accessed 25 April 2016, <http://www.preservationalliance.com/directory/mcmar/index.php/inventory/detail/220>.



Figure 22. The panels used on the Miami Beach Public Library, designed by Herbert A. Mathes (1962), illustrate the expressive texture that could be achieved with architectural precast wall panels.¹¹¹

PRESERVATION IMPLICATIONS

The preservation of mid-century modern architecture has become an initiative with increasing support across the United States, spearheaded by organizations such as DOCOMOMO and their United States chapter. At the national level, the National Park Service and National Trust for Historic Preservation have been giving increasing attention to significant mid-century modern architecture, including buildings constructed with architectural precast panels. Additionally, local organizations have begun inventorying and highlighting mid-century modern architecture, such as Philadelphia's Preservation

¹¹¹ Photo courtesy of: "Miami Beach Public Library," Albert Vrana, last accessed 25 April 2016 <http://albertvrana.com/library.html>.

Alliance's Mid-Century Modern Initiative and Montgomery County's Montgomery Modern program in Maryland.

Despite such initiatives, however, there has been considerable resistance to the preservation of mid-century architecture due to new challenges it presents. For example, mid-century architecture is generally not assigned the same aesthetic value that is assigned to other historic buildings like Drayton Hall in Charleston, South Carolina, and requires that we critically reconsider our current models of preservation. Mid-century architecture also has difficult associations with, for instance, slum clearance and urban renewal; the successful and meaningful preservation of such architecture will require that we figure out how to live with and, more importantly, learn from these histories. Lastly, the building assemblies of mid-century architecture are generally more complicated and vulnerable than those of traditional architecture, since they are often thin, have many joints and connections, and are comprised of multiple types of materials, and they therefore present significant conservation challenges. Due to all of these factors, the preservation of mid-century architecture must be preceded by more complex and nuanced preservation solutions and a re-evaluation of preservation philosophy to address its current shortcomings.

As a part of this endeavor to preserve mid-century architecture, the significance of architectural precast wall panels must be made visible. This concrete technology is historically significant because it played an important role in forging a place for concrete in the architecture of this period and ensuring the material's successful competition with contemporary metal and glass curtain wall systems. Moreover, as illustrated by the above examples, the variety of architectural expressions achieved with precast wall panels through the use of different concrete mixes, surface finishes, surface treatments, and panel shapes make this concrete technology architecturally significant as a character-defining

feature of the buildings constructed with it.¹¹² To conserve this architectural feature successfully, however, the technical challenges of its preservation must be addressed.

¹¹² Character-defining features are those features that contribute to the visual character of a building and can “include the overall shape of the building, its materials, craftsmanship, decorative details, interior spaces and features, as well as the various aspects of its site and environment” (NPS Preservation Brief #17, 1). If a character-defining feature were altered or demolished, the character of the building would be negatively affected and the building’s significance and/or integrity would be compromised.

CHAPTER 4: LITERATURE REVIEW—PATHOLOGIES AND PRESERVATION OF ARCHITECTURAL PRECAST WALL PANELS

INTRODUCTION

This chapter presents information about the state of knowledge regarding the deterioration mechanisms that affect reinforced concrete generally and architectural precast wall panels specifically, as well as the strategies currently utilized in their preservation. Significantly, these strategies are fairly limited and do not tend to prioritize the most important part of this concrete technology: the architectural expression obtained through the specially designed facing concrete mix and the surface finish and/or treatment applied to it.

REINFORCED CONCRETE PATHOLOGIES

As a reinforced concrete assembly, architectural precast wall panels are subject to the pathologies that affect general reinforced concrete, and, therefore, these pathologies must be reviewed. Although well-designed and executed RC can be an extremely durable material—its strength and perceived durability were the primary characteristics that made it an attractive building material, particularly for industrial and infrastructural projects—the porous nature of concrete, the vulnerability of the steel reinforcement, and the tenuous compatibility between the two inevitably lead to the deterioration of the assembly. The pathologies that these lead to are influenced by both internal and external factors.¹¹³ For example, when considering architectural precast panels, some of the internal factors that should be considered include type of aggregates used, water-cement ratio, type of

¹¹³ Bryant Mather, "Concrete Durability," *Cement & Concrete Composites* 26 (2004): 3.

reinforcement, and casting method. Some of the external factors that should be considered include climate, interior building environment, joints between panels, and connections to the structural frame. Consequently, when determining the pathologies that affect a given building assembly, it is essential to consider the external environment, the characteristics of the assembly, and the characteristics of the materials themselves.

The most common mechanism of deterioration affecting reinforced concrete is the corrosion of the internal steel reinforcement, which leads to a loss of material and structural integrity due to cracking and spalling. Corrosion is an electrochemical process that occurs through two primary reactions: the anodic reaction and the cathodic reaction. In the case of steel reinforcement within concrete, the process begins with the anodic reaction, as the steel dissolves in the pore water of the concrete and gives up electrons. However, to preserve electrical neutrality of the steel reinforcement, the electrons given up during the anodic reaction must be accepted elsewhere on the steel surface; this is the cathodic reaction, which occurs through a reaction with oxygen and water. For corrosion to occur, the flow of electrons between these two reactions must be sustained by the presence of an electrolyte, which, in this case, is the pore water of the concrete against the surface of the steel reinforcement. With the production of corrosion products (rust), the steel expands in volume, causing cracking and ultimately spalling of the concrete cover.¹¹⁴

In normal circumstances, the necessary and sufficient factors that must be present for corrosion to occur are moisture, oxygen, and an electrolyte.¹¹⁵ In the case of steel reinforcement in concrete, however, corrosion cannot occur until the surface of the steel

¹¹⁴ John Broomfield, *Corrosion of Steel in Concrete: Understanding, Investigation, and Repair* (New York, NY: Taylor & Francis, 2007), 8.

¹¹⁵ The concept of necessary and sufficient factors was developed by Samuel Harris in his book *Building Pathologies: Deterioration, Diagnostics, and Intervention* (2001). The concept is that if all of these necessary and sufficient factors of a certain pathology are present, then the mechanism of deterioration will occur; if one or more necessary and sufficient factor is absent, the mechanism will not occur. This is an extremely helpful concept to utilize when applying knowledge about mechanisms of deteriorations and attempting to diagnose associated pathologies.

reinforcement is depassivated. At the time of construction, the pH of concrete is typically between 12 and 13.5.¹¹⁶ At this pH level, the steel forms “a very thin, protective oxide known as a passive layer,” which protects the reinforcement from corrosion.¹¹⁷

There are two primary ways the passive layer is destroyed: carbonation and the introduction of chloride ions. As mentioned previously, concrete is a porous material composed of water, cement, and coarse and fine aggregates. When water and cement are mixed to create the paste that binds the coarse and fine aggregates, a hydration reaction occurs, which results in the formation of hydroxides.¹¹⁸ As carbon dioxide from the air penetrates the concrete, a carbonation reaction occurs between the hydroxide and carbon dioxide, resulting in the formation of carbonates and the reduction of the concrete’s pH.¹¹⁹ As the hydroxide ions near the surface carbonate, carbon dioxide must penetrate deeper to react with available hydroxide ions within the concrete. The furthest depth at which carbonation has occurred is called the carbonation front, and when the carbonation front reaches the reinforcement, the passive layer breaks down due to the lower pH. The following diagram illustrates the carbonation of concrete and the resultant deterioration [Figure 23]. The process of carbonation can be expedited by factors such as a high water-cement ratio, low cement content, a short curing period, low strength concrete, highly permeable/porous paste, and insufficient reinforcement cover.¹²⁰

¹¹⁶ John Broomfield, “The Identification and Assessment of Defects, Damage and Decay,” in *Concrete Building Pathology*, ed. Susan Macdonald (Oxford, UK: Blackwell Science Ltd., 2003), 142.

¹¹⁷ Ibid.

¹¹⁸ Susan Macdonald, “Introduction” in *Concrete Building Pathology*, ed. Susan Macdonald (Oxford, UK: Blackwell Science Ltd., 2003), 3.

¹¹⁹ Portland Cement Association, “Types and Causes of Concrete Deterioration,” IS536, 3.

¹²⁰ Ibid., 3.

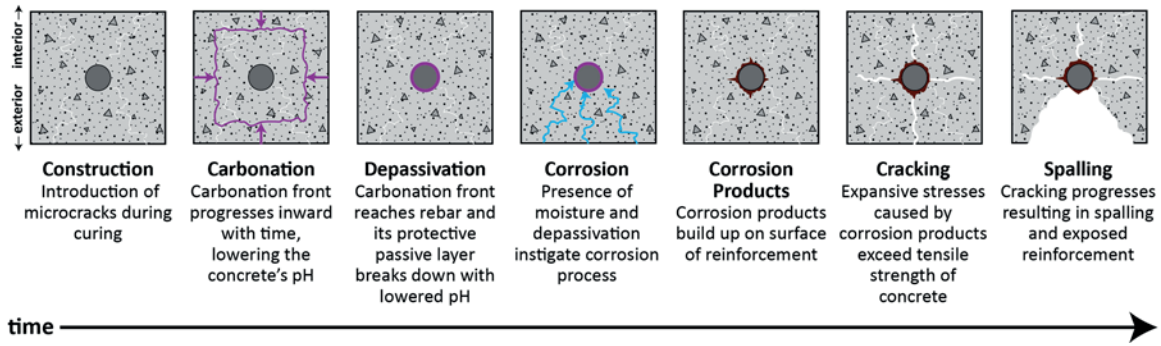

Figure 23. This diagram illustrates one way in which reinforced concrete can deteriorate: the concrete cover begins to carbonate, which ultimately depassivates the reinforcement and leads to its corrosion. Through the process of corrosion and the production of corrosion products, the concrete cover begins to crack and subsequently spall (diagram by author).

A second cause of reduced alkalinity of concrete and depassivation of the steel reinforcement's surface is the introduction of chloride ions into the concrete. Chloride can be introduced to concrete in deicing salts, admixtures that contain chloride, and seawater (in liquid or vapor forms), and the ions travel through the pore structure of the concrete towards the reinforcement. As the chloride ion content reaches a critical threshold at the steel reinforcement (approximately 0.4% by weight of cement), the passive layer is broken down and the reinforcement becomes susceptible to corrosion.¹²¹

Other pathologies that help to enable the corrosion of the internal reinforcement and/or cause cracking of the concrete cover include the chemical reaction of aggregates, aggressive chemical exposure, presence of biological matter on the surface of the concrete, and damage resulting from freeze-thaw cycling. The presence of soluble silicates in the aggregate can result in alkali-silica reactions between silica in the aggregates and hydroxide in the cement paste, which results in the formation of a gel that absorbs moisture, expands,

¹²¹ Broomfield, "The Identification and Assessment of Defects, Damage and Decay," 144.

and can lead to the cracking of the concrete cover.¹²² In addition to chloride attack, as described above, concrete can be subject to acid and sulfate attack, among other chemicals. Acids react with the calcium hydroxides of the cement paste to form water-soluble calcium compounds that leach out of the concrete, increasing the porosity of the concrete and removing latent hydroxides for carbon dioxide to react with.¹²³ Sulfates, which can be introduced through groundwater and soil, react with the hydroxides of the cement paste and result in the formation of ettringite, an expansive substance that causes cracking of the concrete.¹²⁴ Micro-biological growth on the surface of the concrete can produce very strong acids that can both erode the surface of the concrete, making it vulnerable to weathering and carbonation, and penetrate the concrete cover, depassivating the reinforcement and enabling corrosion to occur.¹²⁵

Factors external to the concrete material itself, such as poor detailing, poor drainage, problematic finishes, inadequate design for actual loadings, and inadequate maintenance can also exacerbate the pathologies described above. For example, poor drainage can lead to the introduction of sulfates through groundwater and the formation of ettringite, and inadequate design for actual loadings can lead to the development of internal stresses, which results in cracks that expedite carbonation and expose the reinforcement to additional moisture and oxygen. Because external factors such as these can significantly contribute to the deterioration of RC, they must be identified through surveys and conditions assessments and their influence must be minimized.

¹²² Ibid., 148.

¹²³ PCA, "Types and Causes of Concrete Deterioration," 6.

¹²⁴ Broomfield, "The Identification and Assessment of Defects, Damage and Decay," 149; A. Darimont, "Concrete – Pathology – Secondary Precipitations," *Microscopy Research and Techniques* 25 (1993): 179.

¹²⁵ Shiping Wei, et. al., "Microbiologically Induced Deterioration of Concrete – A Review," *Brazilian Journal of Microbiology*, 44/4 (2013): 1003.

DETERIORATION OF ARCHITECTURAL PRECAST WALL PANELS

In addition to the pathologies that affect general reinforced concrete, there are numerous mechanisms of deterioration unique to architectural precast wall panels due to their composition and the nature of the wall system they comprise. First, there are important geometric considerations. Architectural precast wall panels have a cross-section that is much thinner than cast-in-place concrete walls. The narrow cross-section makes panels vulnerable to bowing and distortion, which can lead to cracking and exposure of the reinforcement.¹²⁶ It also provides less concrete cover over the panel's reinforcement, which can lead to faster carbonation of the concrete and, subsequently, depassivation of the reinforcement.¹²⁷ Upon depassivation, the reinforcement becomes susceptible to the corrosion process, which can result in the cracking of the concrete cover. The vulnerability of the reinforcement can be amplified by aggregate reactions of the facing concrete, such as alkali silica reaction, which leads to cracking and easier penetration of carbonation.¹²⁸ Insufficient or misplaced reinforcement can also lead to cracking of the panel.¹²⁹ Moreover, the thinner cross-section of architectural precast wall panels makes them more sensitive to temperature changes and results in the expansion and contraction of the panel. If this panel movement is sufficiently restrained, the panel can experience deflection and subsequent cracking.¹³⁰

Second, the production process specific to architectural precast wall panels can lead to the development of cracks in various ways. For example, cracks can develop due to improper trowelling of the facing concrete during the casting process or due to concrete

¹²⁶ R.J. Folic, "Classification of Damage and Its Causes as Applied to Precast Concrete Buildings," *Materials and Structures* 24 (1991): 276.

¹²⁷ *Ibid.*, 277.

¹²⁸ M.A. Ozol and D.O. Dusenberry, "Deterioration of Precast Concrete Panels with Crushed Quartz Coarse Aggregate Due to Alkali Silica Reaction," *ACI SP 131-22 Durability of Concrete* (March 1992): 412.

¹²⁹ Folic, "Classification of Damage," 278.

¹³⁰ *Ibid.*

shrinkage occurring during the curing process. The method of curing—in particular, the process of steam curing—has also been identified as a cause of cracking.¹³¹ Architectural precast wall panels may also develop cracks while being stripped from the form or during handling and transportation.¹³²

Third, unlike cast-in-place concrete walls, architectural precast panel wall systems are characterized by connections, including the seat connection of the panel, the tie-back to the structural frame, and connections to control lateral movement, and are bounded by joints. Joint and connection zones are the areas of architectural precast wall panel systems with the largest number of occurrences of damage.¹³³ Connection areas are made vulnerable due to factors such as unintended forces introduced into the wall system and accidental eccentricities occurring during the production and erection phases; these can overload and weaken the connection material, ultimately leading to connection failures.¹³⁴ If the connection material is exposed to moisture and begins to corrode, the volumetric expansion of the connection can compress the material of the panel around it, resulting in fractures, chipping, and excessive wall movement.¹³⁵ Corrosion of the connection material is a particular concern given that, historically, connections were typically fabricated with non-corrosion resistant materials. Recognition of this vulnerability led to the use of hot-dipped galvanized steel connection assemblies, but these too can eventually corrode, especially when in contact with dissimilar metals, mortar, or concrete.¹³⁶

The performance of the joints and the joint material between architectural precast wall panels can also significantly contribute to the deterioration of the panel. If the joint material deteriorates, the panel's ability to accommodate differential movement can be

¹³¹ Ibid., 279.

¹³² Brian J. Pashina, "Crack Repair of Precast Concrete Panels," *Concrete International* (August 1986): 24.

¹³³ Folic, "Classification of Damage," 281.

¹³⁴ Ibid., 282.

¹³⁵ George L. Maness, "Preventing Wall Deterioration," *Journal of Property Management* 56/5 (Sep/Oct 1991): 35.

¹³⁶ Ibid., 36.

impeded and lead to cracking and chipping. Deteriorated joint material also presents more opportunities for moisture to move along the surface of the panels, which can result in erosion of the cement paste and, consequently, increased concrete porosity.¹³⁷ Additionally, deterioration of the joint material allows air and moisture to penetrate the wall system, which can lead to problems of condensation on the backside of the panel.¹³⁸ Condensation can cause discoloration of the panels and corrosion of the connections.¹³⁹ Freeze-thaw cycles will also affect condensation and other moisture in the wall system and cause expansion and contraction of the panel, spalling, and delamination.¹⁴⁰

All of these pathologies and methods of deterioration lead to cracking, which can irreversibly damage the appearance of architectural precast wall panels. Thus, in order to protect the distinguishing expressive finish and/or mix of architectural precast wall panels, preservation efforts should attempt to prevent cracking and other deterioration mechanisms that damage the appearance of architectural precast wall panels.

DETERIORATION DETECTION METHODS

Because deterioration generally occurs from the inside out, it is essential to the preservation of historic reinforced concrete that we understand the condition of the concrete below the surface. There are a variety of surveying strategies that can be employed to attempt to do this. Unfortunately, surveying is usually only instigated by visible and, therefore, significant signs of deterioration. Once implemented, however, surveying techniques can point to areas of incipient deterioration and be used to prevent further

¹³⁷ Paul E. Gaudette and Deborah Slaton, "Preservation of Historic Concrete," *Preservation Briefs* 15 (Washington, DC: National Park Service, Heritage Preservation Services, 2007): 6.

¹³⁸ Todd A. Gorrell, "Condensation Problems in Precast Concrete Cladding Systems in Cold Climates," *Journal of Testing and Evaluation* 39/4 (2010): 1.

¹³⁹ Maness, "Preventing Wall Deterioration," 34.

¹⁴⁰ *Ibid.*

deterioration. Hammer testing, chain dragging, and impact-echo testing are used to determine areas of delamination, or areas of incipient spalling. Hammer testing and chain dragging involve listening to the pitch and tone these instruments make when struck against the concrete surface, while impact-echo testing involves measuring the reflection of transient pulses between an internal delamination and the exterior of the concrete.¹⁴¹ Carbonation testing assesses the depth of the carbonation front by applying phenolphthalein to the cross section of core samples taken from the concrete. The application of Nonlinear Resonant Ultrasound Spectroscopy has also been studied as a means to non-destructively determine the depth of the carbonation front.¹⁴² Mapping half-cell potentials is used to understand where areas of corrosion may be located.¹⁴³ This technique works by measuring the electrode potential across a concrete surface relative to a reference electrode. If the steel is still passive, the potential measured will be small (e.g. 0 to -200 mV), but if the passive layer has been compromised, the potential measured will be a larger negative number (e.g. > -350 mV).¹⁴⁴ Ground (or sound) penetrating radar can be used to characterize concrete thickness, estimate concrete cover over the reinforcement and its approximate location, estimate the size of the rebar, and determine locations of voids and delaminations.¹⁴⁵

Despite the useful information that can be obtained with these surveying techniques, they have significant limitations. In addition to questions about their accuracy, almost all of these techniques are often expensive and require a trained professional to

¹⁴¹ Linnea M. Linton, "Delamination in Concrete: A Comparison of Two Common Nondestructive Testing Methods." *APT Bulletins* 36/2-3 (2005): 22.

¹⁴² F. Bouchaala, et. al., "Carbonation Assessment in Concrete by Nonlinear Ultrasound," *Cement and Concrete Research* 41 (2011): 558.

¹⁴³ Gaudette and Slaton, "Preservation of Historic Concrete," 8.

¹⁴⁴ John P. Broomfield, *Corrosion of Steel in Concrete: Understanding of Steel in Concrete* (New York, NY: Taylor & Francis, 2007), 45.

¹⁴⁵ Giovanni Leucci, "Ground Penetrating Radar: An Application to Estimate Volumetric Water Content and Reinforced Bar Diameter in Concrete Structures," *Journal of Advanced Concrete Technology* 10 (2012): 411.

execute them. Moreover, they can only show what is presently there and have limited predictive value. Further research is therefore required to enhance the utility of these tools.

CURRENT ARCHITECTURAL PRECAST WALL PANEL PRESERVATION STRATEGIES

Despite the numerous deterioration mechanisms that can damage architectural precast wall panels and the enhanced concern for preserving the original material, there are few repair or conservation strategies available that specifically address these needs. The repair and conservation of architectural precast panels rely heavily on cleaning the panel surface, replacing joint sealants, sealing cracks, and patching localized areas of spalling. With respect to patching in particular, workmanship is extremely important to the success of the repair and the patch location must be well prepared: any exposed internal reinforcement must be cleaned and the concrete surface must be prepared to accept the patch material.¹⁴⁶ The patch material should be compatible with the original concrete in characteristics such as compressive strength, modulus of elasticity, and thermal expansion, and the characteristics of the patch material, such as bonding strength, permeability, and drying shrinkage, must be evaluated to ensure a successful patch. When patching aesthetically significant concrete, the mix of the patching material should be carefully formulated to match the appearance of the original concrete; to achieve a successful match, it is imperative to prepare numerous samples and conduct mock-ups on-site. Even with extensive efforts to match the repair's mix with the original concrete, patches often stubbornly stand out and have a propensity to fail prematurely, especially if the material surrounding a patch is vulnerable to the same deterioration that caused the original spall.

¹⁴⁶ ACI Committee 546, *Guide to Concrete Repair* (Detroit, MI: American Concrete Institute, 2014).

The repair of concrete facades, including architectural precast wall panels, also often includes the application of a protective coating to prevent carbonation and protect the interior of the concrete.¹⁴⁷ Protective coatings, however, can greatly change the appearance of an historic concrete structure and irreversibly alter the original surface finish of the concrete.

CONSERVATION STRATEGIES WITH POTENTIAL

There are some conservation methods that have the potential to more successfully preserve the appearance of architectural precast wall panels by attempting to slow and even reverse the factors that enable corrosion, and therefore cracking, to occur: impregnation treatments, electrochemical realkalization, and cathodic protection. While all three of these methods help prevent future corrosion, vital to their success is the patching of any damaged sections of concrete to minimize reinforcement exposure. Additionally, although all of these treatments can be extremely effective, they are also expensive and require expertise in their execution.¹⁴⁸

Impregnation treatments are a conservation method borrowed from the conservation of stone. The treatment involves applying a chemical formulation to the surface of the reinforced concrete and allowing the formulation to penetrate the cross section of the concrete through the material's pore network.¹⁴⁹ The objective of impregnation treatments as applied to reinforced concrete is to "[reduce] the materials porosity close to the reinforcement, in order to improve its pull-out strength and behavior...[and reduce] the materials porosity and permeability, in order to improve their

¹⁴⁷ David Reid-Simms and John Keble, "Façade Concrete Repairs to UK's Decent Homes Standard," *Concrete* 42/1 (Feb 2008): 32; Damian Meyers, "Face Lift for Car Park," *Concrete* 40/5 (June 2006): 37.

¹⁴⁸ Gaudette and Slaton, "Preservation of Historic Concrete," 15.

¹⁴⁹ Elisa Franzoni, et. al., "Improvement of Historic Reinforced Concrete/Mortars by Impregnation and Electrochemical Methods," *Cement & Concrete Composites* 49 (2014): 51.

resistance to aggressive agents,” such as chloride ions and additional carbonation.¹⁵⁰ Franzoni, et. al., tested the effectiveness of impregnating reinforced concrete with a solution of ethyl silicate in organic solvent, a formulation used in the consolidation of historic stone, and found that the treatment was effective in both reducing the concrete’s susceptibility to carbonation and improving the corrosion resistance of the internal reinforcement.¹⁵¹ Significantly, the efficacy of the treatment was found to increase with more porous concrete because the treatment could impregnate the material more thoroughly. Impregnation has been used in the conservation of architectural concrete because it does not change the color of or form a film on the surface of the concrete, but more research must be conducted to understand how this treatment affects different surface finishes and/or treatments.¹⁵²

Cathodic protection is a method by which the steel reinforcement in RC is protected from further corrosion: through the introduction of a superficial source of electrons, the anodic reaction on the reinforcement ceases. There are two types of cathodic protection systems: the impressed current system and the sacrificial anode system. The impressed current system is an active system that works by “passing a small direct current (DC) from a permanent anode on top of or fixed into the concrete to the reinforcement.”¹⁵³ The sacrificial anode system is a passive system that is used less often and involves connecting the steel reinforcement to a less noble, or sacrificial, metal on which the anodic reaction will occur, with the result that the secondary metal corrodes rather than the steel.¹⁵⁴ While these methods of cathodic protection can be extremely effective at slowing the rate of corrosion, they have distinct disadvantages. The impressed current system requires an

¹⁵⁰ Ibid., 57.

¹⁵¹ Ibid., 58.

¹⁵² Saija Varjonen, Jussi Mattila, Jukka Lahdensivu, and Matti Pentti, “Conservation and Maintenance of Concrete Facades: Technical Possibilities and Restrictions,” Research Report 136 (Tampere University of Technology: Institute of Structural Engineering, 2006): 15.

¹⁵³ Broomfield, *Corrosion of Steel in Concrete*, 141.

¹⁵⁴ Ibid., 144.

immense amount of monitoring, adjustment, and maintenance to ensure long-term protection and is very expensive to install.¹⁵⁵ The sacrificial anode system is less expensive, but the anode must be replaced whenever it is depleted from the anodic reaction in order for the treatment to remain effective. Thus, both systems of cathodic protection are permanent, often alter the appearance of the building, and must themselves be maintained to ensure successful protection of the reinforced concrete. Radaelli, et. al., studied the effectiveness of installing a cathodic protection system on slender carbonated concrete elements using a few localized galvanic anodes.¹⁵⁶ The study examined this particular method as a way of protecting corroding reinforcement in situations where the preservation of the original surface, shape, and material is important, but they found that the costs of this system were prohibitively expensive to be used preventively, although the system has the potential to be used “where and when corrosion has initiated and propagates due to carbonation.”¹⁵⁷

Electrochemical realkalization is a technique that aims to restore the alkalinity of carbonated reinforced concrete to reinstate the protective passive layer around the internal reinforcement. This objective is achieved by either soaking the concrete in an alkaline solution or by applying an external current to the steel reinforcement by way of a temporary anode system, which is placed on the surface of the concrete.¹⁵⁸ Unlike cathodic protection, electrochemical realkalization using an external current is a temporary treatment technique and does not affect the surface of the concrete after the treatment

¹⁵⁵ Gaudette and Slaton, “Preservation of Historic Concrete,” 15.

¹⁵⁶ Elena Radaelli, et. al., “Cathodic Protection with Localised Galvanic Anodes in Slender Carbonated Concrete Elements,” *Materials and Structures* 47 (2014): 1839.

¹⁵⁷ *Ibid.*, 1854.

¹⁵⁸ *Ibid.*; Luca Bertolini, Maddalena Carsana, and Elena Radaelli, “Conservation of Historical Reinforced Concrete Structures Damaged by Carbonation Induced Corrosion by Means of Electrochemical Realkalisation,” *Journal of Cultural Heritage* 9 (2008): 377.

apparatus is removed.¹⁵⁹ Nevertheless, this is also an expensive and complex conservation method and has only been used sporadically in the conservation of architectural concrete.¹⁶⁰

Although all of the preservation strategies described above can help to reduce future deterioration and repair damage that has occurred, their implementation has been reactive in nature. Thus, they do not prevent or slow down the rate of deterioration before damage has occurred. Adopting an approach that predicts and prevents deterioration, rather than reacts to it, will ultimately preserve architectural precast wall panels the most successfully.

TOWARDS A PREVENTIVE CONSERVATION APPROACH

Preventive conservation is an approach to conservation based on identifying ways to prevent or slow down deterioration. Typically, conservation and restoration campaigns are enacted in reaction to significant deterioration that necessitates large conservation efforts to save the object or structure. Such conservation and restoration campaigns are expensive, and, by delaying action until deterioration is so severe as to require large conservation campaigns, there is a great risk of losing original fabric and integrity.

The concept of preventive conservation as a distinct approach to preservation is fairly new: publications about this approach began to appear in the late 1980s and early 1990s. This approach has been most frequently applied to the preservation of object collections in museums, although it has been slowly gaining popularity in building preservation. In the arena of object collections, preventive conservation relies on the ability to control the environment in which the objects are located to attain the perfect balance

¹⁵⁹ Ibid.

¹⁶⁰ Varjonen, et. al., "Conservation and Maintenance of Concrete Facades," 16.

between temperature, relative humidity, light exposure, etc.¹⁶¹ In this way, various threats caused by an imbalance of the above factors can be minimized and the mechanisms of deterioration can be better predicted. For buildings, however, utilizing a preventive conservation approach is extremely complex and relies on systems thinking to try to understand how all of the potential mechanisms of deterioration and their necessary and sufficient factors relate.¹⁶² To begin to understand a building as a system, the components of the building and the factors that affect it must be understood; the condition of these components must then be assessed and ultimately monitored to begin to predict threats.¹⁶³ For this reason, preventive conservation as applied to buildings is often about maintenance. Unfortunately, many building stewards often minimize regular maintenance due to tight budgets and the inability to see the benefits of maintenance over a short period of time.¹⁶⁴ In contrast, large preservation campaigns appear to be more important and gratifying despite their expense and the fact that they put the historic fabric of the building in jeopardy.¹⁶⁵

Nevertheless, a preventive conservation approach is the most effective approach for preserving architectural precast wall panels because of their important architectural expression and the way they generally deteriorate from the inside out. The successful preservation of buildings constructed with this concrete technology requires an understanding of concrete pathologies in general coupled with an understanding of the building's context and history in order to begin to predict potential mechanisms of

¹⁶¹ Jeffrey Levin, "Preventive Conservation," *The Getty Conservation Institute Newsletter* 7/1 (Spring 1992): 1.

¹⁶² Robert Waller and Stefan Michalski, "Effective Preservation: From Reaction to Prevention," *The Getty Conservation Institute Newsletter* 19/1 (Spring 2004): 8.

¹⁶³ Hugo Entradas Silva and Fernando M.A. Henriques, "Preventive Conservation of Historic Buildings in Temperate Climates. The Importance of a Risk-Based Analysis on the Decision-Making Process," *Energy and Buildings* 107 (2015): 26.

¹⁶⁴ Nigel Dann and Timothy Cantell, "Maintenance: From Philosophy to Practice," *Journal of Architectural Conservation* 11/1 (2005): 42; Jeffrey Levin, "Preventive Conservation," 2.

¹⁶⁵ Levin, "Preventive Conservation," 2.

deterioration. Such predictions should be accompanied by conditions assessments and monitoring, as well as a maintenance/conservation plan that aims to prevent deterioration from occurring—keeping the necessary and sufficient factors for mechanisms to occur at bay. Minimal research has been performed on the applicability of preventive conservation plans to historic concrete structures in general. However, Chew et. al. proposes a methodology for evaluating curtain wall and cladding facades, which could be generally applied to buildings constructed with architectural precast wall panels. This methodology provides a framework to aid in identifying technical risk factors associated with design, building profile, environment and usage, construction quality, maintenance quality, and customer satisfaction.¹⁶⁶ Utilizing such an evaluation methodology for regular inspection of historic concrete structures, in conjunction with the use of nondestructive evaluation techniques and monitoring, as explored by Goncalves in her thesis “Corrosion Prevention in Historic Concrete: Monitoring the Richards Medical Laboratory,” can greatly enhance a building steward’s ability to predict and prevent deterioration.¹⁶⁷ Indeed, the successful preservation of all historic concrete structures is dependent upon our ability to predict problems.

By adapting Jeffrey Levin’s framework for preventive conservation of object collections, the essential stages of developing preventive conservation plans can be identified as 1) identifying possible threats to the structure, 2) substantiating the risk of these threats to prioritize them, 3) identifying cost-efficient means to measure the risk of these threats, and 4) developing methods to reduce or eliminate the risk of these threats.¹⁶⁸

In essence, this thesis contributes to the first stage of this framework by identifying

¹⁶⁶ M.Y.L Chew, S.S. Tan, and K.H. Kang, “A Technical Evaluation Index for Curtain Wall and Cladding Facades,” *Structural Survey* 22/4 (2004): 211.

¹⁶⁷ Ana Paula A Gonçalves, “Corrosion Prevention in Historic Concrete: Monitoring the Richards Medical Laboratory,” University of Pennsylvania Master’s Thesis (1 January 2011), 14.

¹⁶⁸ Levin, “Preventive Conservation,” 3.

potential threats to architectural precast wall panels and predicting deterioration. It is important to note, however, that the threats identified in this thesis, which are derived from an evaluation of past recommended practices and other technical documents, must also be accompanied by a thorough investigation of the specific building in question and its environment to create a comprehensive understanding of the building as a system.

CONCLUSION

Architectural precast wall panels are subject to a variety of pathologies, including those that occur in general reinforced concrete and those that arise from the unique composition of this concrete technology. Because of the significant appearance and design of architectural precast wall panels, the current reactive conservation strategies of sealing and patching damaged architectural precast wall panels are inadequate and result in the loss of original fabric, which reduces the integrity of the architecture and diminishes the evidence of this important concrete technology. Instead, efforts should be made to predict and prevent deterioration rather than respond to it. To successfully predict and slow down the deterioration of architectural precast wall panels, the factors that may contribute to their deterioration must be identified. As the first step in this process, we must understand the technological evolution of architectural precast wall panels.

CHAPTER 5: TECHNOLOGICAL EVOLUTION OF ARCHITECTURAL PRECAST WALL PANELS, 1945-1975

INTRODUCTION

Beginning in the early twentieth century, the trend towards standardization of the building industry resulted in the publication of standards and guidance to ensure quality and competitiveness in the production of building materials. Although the impetus for standardization of the building industry in the United States was the development of metals, standardization of all building materials became imperative with the end of World War II and the construction boom that followed.¹⁶⁹ Recommended practices and other technical documents that were published to inform the design, production, and assembly of architectural precast wall panels between 1945 and 1975 provides us with valuable information about this concrete technology and its technological evolution.

Reviewing the industry literature reveals, however, that throughout this thirty-year period the industry was hesitant to make specific recommendations or establish standards out of deference to the judgment and experience of individual precasters. The significance of precasters' artistic contribution in the design of the concrete mix and the execution of finishes and surface treatments was greatly appreciated, and it was recognized that "attempts to define this intangible property of workmanship [could] result in restrictions that prohibit the manufacturer from using a process that offers the best possibilities of success."¹⁷⁰ For this reason, recommendations and guidance about topics such as mixing, casting, finishes and surface treatments, and formwork are more limited in comparison to guidance about design objectives, material selection, reinforcement, handling, connection

¹⁶⁹ Tomlan, "Building Modern America," 9.

¹⁷⁰ Leabu and Adams, "Fabrication, Handling and Erection of Precast Concrete Wall Panels," *ACI Journal* (April 1970): 313.

design and materials, and joint design and materials. The variability resulting from the judgment and experience of the individual precasters, as well as the limited information about particular areas of the production process, makes the preservation of architectural precast wall panels more difficult. Analyzing the documents that resulted from this push towards standardization is all the more important, however, because they help to convey the state of and changes in knowledge across this time period, thereby providing invaluable information to be used in the preservation of this concrete technology.

The majority of the documents consulted from this period were published by the American Concrete Institute (ACI) and convey ACI's dedication to this concrete technology. Specifically, the vast majority of the documents were published by ACI Committee 533, which was founded in 1964 and was dedicated to "supplement[ing] existing information with those practices and methods peculiar to precast concrete wall panels."¹⁷¹ Several documents were also published by the Precast/Prestressed Concrete Institute (PCI), but these documents are from after 1966 when PCI started its own committee, the Plant Production of Architectural Precast Concrete Products Committee, which aimed to contribute to the improvement and standardization of the architectural precast industry. Finally, the Portland Cement Association (PCA) published a select few documents dedicated to the production and assembly of architectural precast wall panels. By analyzing these documents to understand the technological evolution of architectural precast wall panels, we can begin to consider the ways in which this concrete technology may be vulnerable. It should be remembered, however, that this survey is not exhaustive and the vulnerabilities drawn from it are not exclusive but rather provide a thorough starting point.

Important subjects to consider in the evolution of architectural precast wall panels include design objectives, the materials used, the form design and materials, methods of

¹⁷¹ Ibid., 312.

casting and consolidation, type and placement of reinforcement, curing methods, surface finishes and treatments, stripping from the form, storage, transport to the construction site, handling and erection, connection design and materials, joint design and materials, and cleaning, repairs, and coatings. Exploring the issues associated with testing architectural precast wall panels, improving their thermal value, preventing bowing and warping, and preventing damage to the panel appearance during production and assembly are also significant to our understanding of this concrete technology.

PRECAST'S POTENTIAL: 1945-1950

Between 1945 and 1950, the only article published by ACI that discussed architectural precast wall panels was written by A.C. Grafflin in 1948. Promoting the production of precast building elements, including architectural precast wall panels, Grafflin emphasized the use of precast as a way to standardize, simplify, and mechanize concrete's role in the building industry.¹⁷² To further promote the use of "cementstone" (the term he applied to precast concrete, perhaps to smooth the transition from the use of cast stone) Grafflin compared this method of concrete construction to its competitor, steel construction. He claimed that the cost of construction with cementstone was comparable to non-fireproofed structural steel and "at least 20 percent less than steel fire-proofed, or poured-in-place concrete."¹⁷³ This single article did not, however, provide any technical information about the production and assembly of architectural precast wall panels, thereby illustrating the industry's limited interest in this technology before 1950.

¹⁷² A.C. Grafflin, "Cementstone Precast Construction," *Journal of the American Concrete Institute* (November 1948): 193.

¹⁷³ *Ibid.*, 202.

1950-1965: PRE-ACI SYMPOSIUM

Beginning in the 1950s, publications about the production, design, and assembly of architectural precast wall panels began to appear with more regularity. Between 1950 and 1965, the majority of the articles were published by ACI and written by the men who would form ACI's Committee 533 in 1964. ACI's increased attention to this technology conveys the concrete industry's growing interest in developing and standardizing architectural precast wall panels. This growing interest is also reflected by the Portland Cement Association's 1954 publication specifically about precast wall panels and the publication of the 1958 book *The Contemporary Curtain Wall* by William Dudley Hunt, which examines the properties and significance of curtain wall systems and the materials they are made of, including architectural precast wall panels.

Many of the general problems in the design, production, and assembly of architectural precast wall panels were identified in these early publications. For example, the challenge of optimizing the size of the panel simultaneously to reduce the number of joints but also to accommodate contemporary handling equipment and transportation methods was established as a significant design consideration in the 1950s. Smaller panels had the advantages of being easily handled and keeping lateral movement within acceptable limits, which Victor Leabu, one of the leading members of ACI Committee 533, highlighted as being a significant design consideration to improve panel performance and reduce the potential for deflection and cracking.¹⁷⁴ Larger panels, however, had distinct economic advantages, such as requiring fewer joints and fewer handling actions, which led to a trend

¹⁷⁴ Victor F. Leabu, "Problems and Performance of Precast Concrete Wall Panels," *Journal of the American Concrete Institute* (October 1959): 287.

throughout this period towards their use; later improvements in handling equipment and the rising use of lightweight aggregates helped to enable this development.¹⁷⁵

By the 1960s, durability became a primary concern in the design of architectural precast wall panels. In 1964, ACI Committee 533 recommended that the facing concrete have a compressive strength of at least 5000 psi at 28 days to ensure the panel's durability.¹⁷⁶ The Committee also recommended the introduction of air entrainment into the panel's concrete mix to improve durability, although a specific fixed air content was not recommended due to the variety of mixes used in the production of architectural precast panels.¹⁷⁷

Many of the publications from this period offered guidance about how to reduce cracking during the production process and in storage. For instance, to improve the quality of the panels before their storage in the yard, and, consequently, to reduce cracking, PCA promoted the use of steam curing, the removal of excess water by vacuum from the wet concrete, or the application of curing compounds.¹⁷⁸ In this same publication, PCA claimed that broom or swirl finishes helped to reduce surface cracking.¹⁷⁹ To enable earlier stripping and reduce cracking resulting from this process, both PCA and ACI Committee 533 promoted the use of high strength concrete.¹⁸⁰ The use of high strength concrete also resulted in the more reliable reuse of the panel forms, which then increased production efficiency. Finally, PCA emphasized the importance of evenly distributing stresses during all handling actions to reduce cracking.¹⁸¹

¹⁷⁵ Thomas S. Gilbane, "Precast Concrete Panel Multistory Construction," *Journal of the American Concrete Institute* (May 1950): 730.

¹⁷⁶ J.A. Hanson, "Tests for Precast Wall Panels," *Journal of the American Concrete Institute* (April 1964): 377.

¹⁷⁷ *Ibid.*, 378.

¹⁷⁸ "Precast Concrete: Wall Panels," PCA, 12.

¹⁷⁹ *Ibid.*, 15.

¹⁸⁰ *Ibid.*, 12; Hanson, "Tests for Precast Wall Panels," 376.

¹⁸¹ "Precast Concrete: Wall Panels," PCA, 12

As early as the 1950s, publications recognized the problem of variations in color between adjacent panels and discoloration of individual panels. To reduce such variations, Leabu recommended in his 1959 publication that the production of panels should be as consistent as possible, including using cement and aggregates from the same sources throughout a given project. He also suggested that measures should be taken in the field to minimize shade variations, such as matching individual panels before erection.¹⁸²

During this period, much attention was already being given to the design of connections. In its 1954 publication, PCA established connection design fundamentals: they must be fire resistant, enable the accurate alignment of the panels, be protected to prevent corrosion, accommodate lateral movement, and accommodate the dead and live loads for which the panels were designed.¹⁸³ To achieve these objectives, the connection material must be ductile and strong.¹⁸⁴ The placement of connection assemblies was also a concern, with claims that anchor inserts in the face of the panels could mar the surface and should, therefore, be avoided.¹⁸⁵ Still, the understanding of the problems associated with connection assemblies was limited. For example, protecting connections to prevent corrosion merely meant protecting them from the atmosphere, without consideration of the importance of moisture and vapor penetrating the wall system. Similarly, welded connections were perceived as unproblematic, although this perception changed considerably with experience.¹⁸⁶

The significance of joints to the success of architectural precast wall panel systems was also emphasized during this period. In their 1962 publication, W. Howard Gerfen and John R. Anderson stressed the importance of designing joints to accommodate the

¹⁸² Leabu, "Problems and Performance of Precast Concrete Wall Panels," 289.

¹⁸³ "Precast Concrete: Wall Panels," PCA, 8-12.

¹⁸⁴ Leabu, "Problems and Performance of Precast Concrete Wall Panels," 297.

¹⁸⁵ "Precast Concrete: Wall Panels," PCA, 12.

¹⁸⁶ *Ibid.*, 10.

movement of the panels caused by their expansion and contraction to avoid joint failure.¹⁸⁷ Additionally, they highlighted the role of joints in preventing water from penetrating the wall system, promoting designs that created more convoluted paths for water to travel over square-ended panels [Figure 24].¹⁸⁸

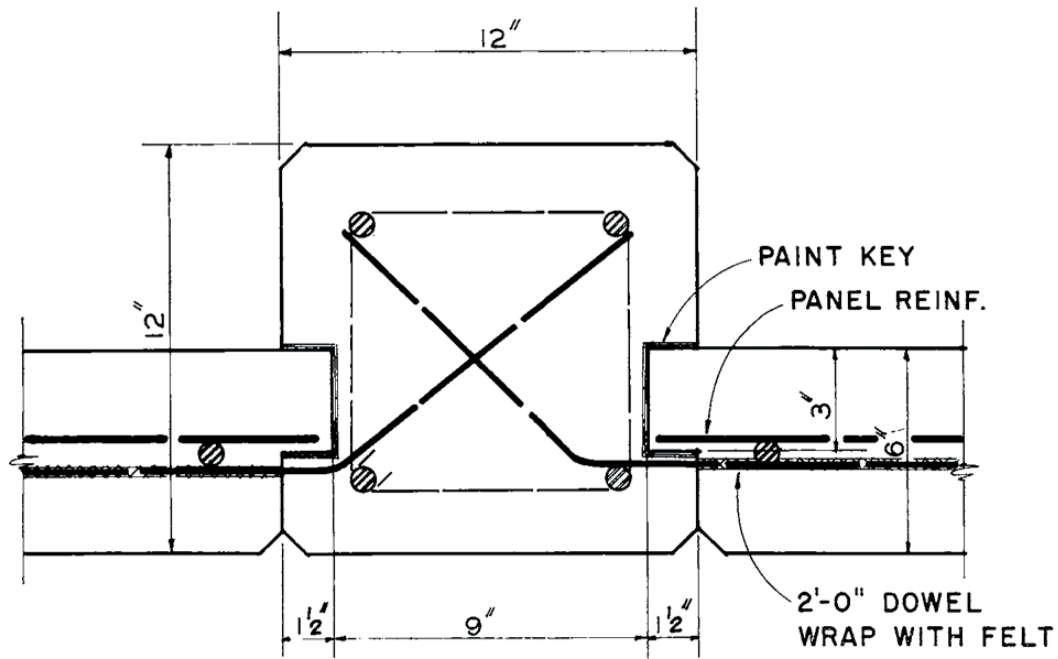

Figure 24. Detail of a joint that convolutes the path water must travel to penetrate the wall system.¹⁸⁹

By 1964, the problem of testing architectural precast wall panels became apparent, with the result that the newly formed ACI Committee 533 dedicated an entire article to this topic. At the time, there were no tests specific to architectural precast wall panels and their performance, so a variety of tests for reinforced concrete were adapted to this specific

¹⁸⁷ W. Howard Gerfen and John R. Anderson, "Joinery of Precast Concrete," *Journal of the American Concrete Institute* (October 1962): 1435.

¹⁸⁸ *Ibid.*, 1437.

¹⁸⁹ Photo courtesy of: Gerfen and Anderson, "Joinery of Precast Concrete," 1436.

concrete technology; these, however, led to inconsistent and even contradictory results.¹⁹⁰ To complicate matters further, the variety of panel types and concrete mixes made prescribed tests problematic. In an attempt to overcome these challenges, ACI Committee 533 proposed simple, basic tests by which the quality and durability of architectural precast wall panels could be measured.¹⁹¹ These tests measured the compressive strength of the concrete, which was used as a measure of the panel's durability, and Committee 533 recommended the use of 6x12 in. cylinder or 4 in. cube samples. The 4 in. cube sample size deviated from the cube sample size of 2 in. used in the testing of normal structural reinforced concrete to accommodate the large coarse aggregate in the facing concrete.¹⁹² ACI Committee 533 recognized, however, that these compressive strength tests could still provide unreliable results and therefore promoted core tests of the actual concrete in the panel as the most dependable test.¹⁹³ Tests for freeze-thaw were seen as unnecessary because of the vertical position of the panels in the wall system, which was inaccurately thought to sufficiently protect the panels from becoming saturated and susceptible to freeze-thaw damage.¹⁹⁴

The importance of improving the thermal value of architectural precast wall panels to remain competitive with metal and glass curtain walls was established during the period between 1950 and 1965. The development of sandwich panels, as well as panels made of lightweight concrete, aimed to enhance the thermal value of precast panels.¹⁹⁵ In his 1959 article, Leabu acknowledged some of the problems in sandwich panels that had to be resolved for their future success, including the thermal bridges created by the ribs and solid

¹⁹⁰ Hanson, "Tests for Precast Wall Panels," 370.

¹⁹¹ *Ibid.*

¹⁹² *Ibid.*, 372.

¹⁹³ *Ibid.*, 375.

¹⁹⁴ *Ibid.*, 376.

¹⁹⁵ Leabu, "Problems and Performance of Precast Concrete Wall Panels," 288.

concrete sections connecting the outer wythes of concrete and the condensation caused by the temperature gradients enabled by the panel design [Figure 25].¹⁹⁶

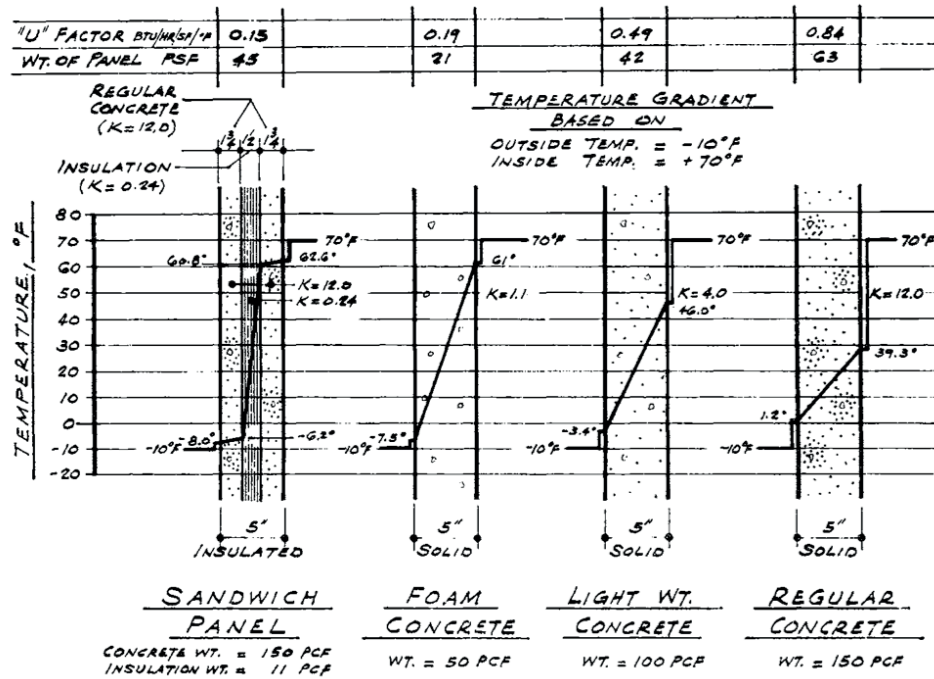

Figure 25. Temperature gradient through different types of panels.¹⁹⁷

Relatedly, Leabu quickly identified bowing and warping as a problem with many precast panels, especially sandwich panels.¹⁹⁸ He highlighted some of the causes of bowing and warping, such as the temperature and moisture differentials across the cross-section of the panel and curing shrinkage, which was thought to be exacerbated by casting panels in a flat, horizontal position since this causes uneven curing and evaporation of moisture throughout the depth of the panel.¹⁹⁹

¹⁹⁶ Ibid., 297; "Precast Concrete: Wall Panels," PCA, 9.

¹⁹⁷ Photo courtesy of: Leabu, "Problems and Performance of Precast Concrete Wall Panels," 292.

¹⁹⁸ Ibid., 291.

¹⁹⁹ Ibid., 296.

Many topics were given almost no attention during the period between 1950 and 1965. For instance, there was no discussion about the mixing of the facing and backup concrete, the design of and material used for the panel formwork, and methods of casting, producing particular surface finishes and surface treatments, storage, or handling and erection. Minimal attention was granted to the type, placement, or cover of panel reinforcement, which was generally placed at the interface between the facing concrete and backup concrete during casting. One article from 1950 revealed a concern for corrosion protection of reinforcement in thin precast concrete sections, although this study was not specific to architectural precast panels. The study, which was inspired by the Navy's extensive use of precast technology in the construction of its warehouses, attempted to identify the corrosion rate of steel reinforcement in thin precast concrete sections, but its results could not establish a functional relationship between the cross-sectional area of the reinforcement and the rate of corrosion.²⁰⁰ These gaps in knowledge began to be filled in with the most comprehensive publication on architectural precast wall panels to date: the 1965 ACI Symposium.

1965 ACI SYMPOSIUM

In 1965, ACI Committee 533 hosted a symposium focused on the subject of architectural precast wall panels. The Symposium and the publications that resulted from it provided an immense amount of information about the design, production, and assembly of this concrete technology that would ultimately spike the interest of the concrete industry. Committee 533 presented information focused on materials and tests; design trends and standards; the manufacturing process; bowing, warpage, and movement; and the flexural

²⁰⁰ D.H. Pletta, E.F. Massie, and H.S. Robins, "Corrosion Protection of Thin Precast Concrete Sections," *Journal of the American Concrete Institute* (March 1950): 525.

stiffness of sandwich panels. To provide context, Committee 533 also presented a brief historical review of the use of architectural precast wall panels and a commentary on their use in mid-century architecture. Reviewing these documents reveals how the industry aimed to improve this concrete technology to ensure its sustained use in mid-century architecture.

Design Objectives

The 1965 Symposium reiterated the precast panel industry's reliance on the experience and judgment of precasters and the difficulty of establishing a standardized design practice or recommended design guide, but it also acknowledged the need to standardize the industry to ensure quality.²⁰¹ During the 1965 Symposium, ACI Committee 533 highlighted the major quality aspects that must be achieved, including good consolidation, high strength, low moisture absorption, a pleasing appearance, and resistance to freeze-thaw damage.²⁰² To attain this quality, Committee 533 presented the following preliminary design recommendations:

- Panel design should consider concrete shrinkage, temperature differential, creep, prestressing, handling and erection loads, and eccentric loads when necessary;
- The effective section for the different types of panels must be defined to facilitate calculations;
- The height to thickness ratio should be less than or equal to 50 to avoid buckling;

²⁰¹ Leabu, "Precast Concrete Wall Panels: Design Trends and Standards," 31.

²⁰² Phillip W. Gutmann, "Precast Concrete Wall Panels: Manufacturing Processes," *Symposium on Precast Concrete Wall Panels*, ACI Publication SP-11 (1965), 52.

- Allowable deflection should be less than $h/240$ and no greater than $\frac{3}{4}$ in. (as opposed to the standard $h/360$ for other structural members); and,
- The clear distance between lateral supports should not exceed 32 times the least width of the compression flange or effective panel thickness.

Material Selection

For the first time, ACI recommended specific materials to be used in the production of architectural precast wall panels, including white or gray portland cement (Types I, IA, III, or IIIA), normal weight or lightweight structural aggregate (with maximum aggregate size not exceeding $\frac{3}{4}$ in), and air entrainment to improve the durability of the panels.²⁰³ For the facing concrete, which can be composed with aggregates such as limestone, quartz, marble, granite, glass, and ceramics, Committee 533 made particular recommendations. First, to maximize economy of production, the facing concrete should only be thick enough to prevent the backup concrete from showing. Second, the facing aggregate should be gap-graded to obtain the desired aesthetic for exposed aggregate finishes—a recommendation resulting from the extensive experimentation of the Earley studio.²⁰⁴ Third, hard, durable aggregates with service records should be used to avoid alkali reactivity and similar problems. Finally, the recommended minimum 5000 psi compressive strength at 28 days remained from earlier articles, with the addition that facing concrete should contain 6 bags of cement per cubic yard of concrete for maximum density and minimum permeability.²⁰⁵ For the backup concrete, by contrast, Committee 533 recommended a minimum 4000 psi compressive strength, a recommendation first presented in the 1965 Symposium, although

²⁰³ J.A. Hanson and D. P. Jenny, "Precast Concrete Panels: Materials and Tests," *Symposium on Precast Concrete Wall Panels*, ACI Publication SP-11 (1965), 21.

²⁰⁴ Cellini, "The Development of Precast Exposed Aggregate Concrete Cladding," 52.

²⁰⁵ Hanson and Jenny, "Precast Concrete Panels: Materials and Tests," 23.

they also cautioned that the properties of the backup concrete should be comparable to those of the facing concrete to minimize the effects of differential properties.²⁰⁶ Despite the higher strength requirement, the facing concrete mix tended to have a higher slump (4 to 6 in.) to achieve workability for placement, while the backup concrete was drier to absorb the excess water from the facing concrete mix.²⁰⁷

ACI Committee 533 also presented information about the use of admixtures. To attain high early strengths, Committee 533 recommended using Type III cement and a good curing method instead of accelerating admixtures. The Committee did not recommend the use of retarding admixtures, while water-reducing admixtures could be used to reduce the water content of the facing concrete while maintaining a high level of workability.²⁰⁸ Pigments could be added to obtain colored concrete, but Committee 533 recommended that the pigment content be limited to 5%, for contents over this value did not intensify the color further.²⁰⁹ Moreover, pigments should be added to the cement in the dry state and mixed with white cements to attain more vibrant colors.

Reinforcement Design and Materials

Recommendations about reinforcement were not introduced into publications until the 1965 Symposium. The information presented in the Symposium revealed that a variety of types of reinforcement were already used in precast panels, including structural, intermediate, and high strength deformed bars; black or galvanized wire fabric with a wide variety of mesh spacings and wire gages, and the recent development of mesh with

²⁰⁶ Ibid., 21.

²⁰⁷ Ibid., 23.

²⁰⁸ Ibid., 24.

²⁰⁹ Ibid., 25.

deformed wire.²¹⁰ The Symposium highlighted that the precast industry relied on the “Minimum Requirements for Thin-Section Precast Concrete Construction” (ACI 525-63) for reinforcement placement and cover requirements.²¹¹ From this publication, which was not architectural precast panel specific, the minimum cover for reinforcement was 3/8 in., and for panels less than 3 in. thick, 2x2 wire mesh was recommended [Figure 26].²¹² Galvanized mesh was recommended for minimum cover, but for covers greater than 3/4 in., galvanized reinforcement was deemed unnecessary.

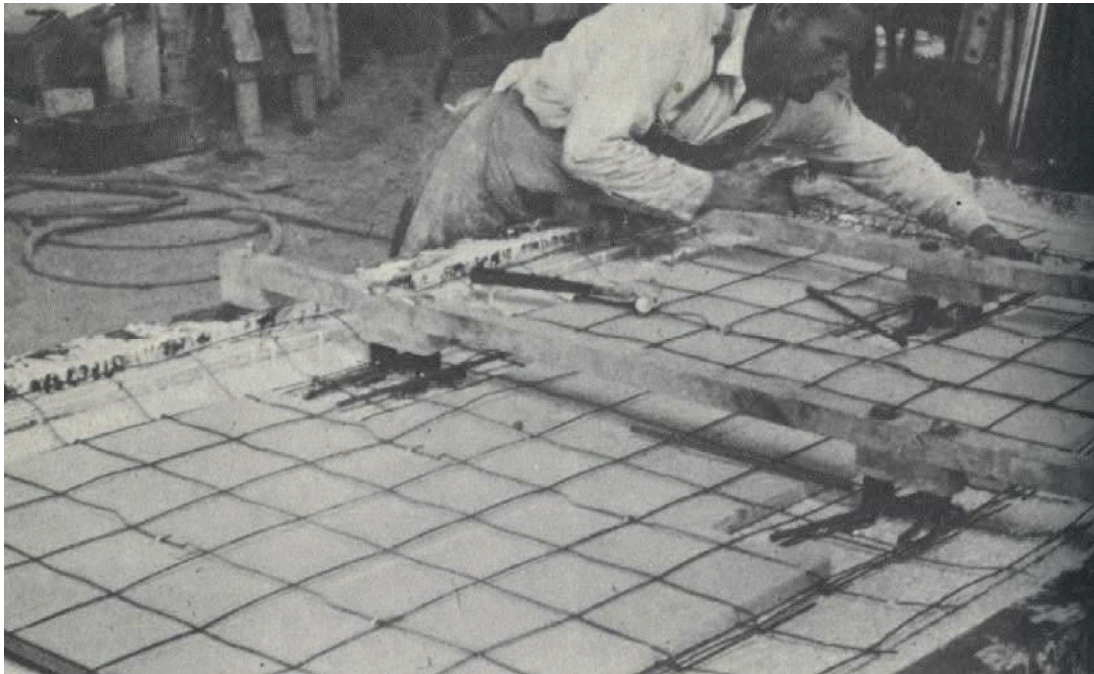

Figure 26. A precaster laying wire mesh reinforcement onto a precast panel before applying the backup concrete.²¹³

²¹⁰ Ibid.

²¹¹ Ibid.

²¹² At this time, the recommended concrete cover for beams and girders was 1 ½ in, according to the 1963 *Building Code Requirements for Reinforced Concrete*.

²¹³ Photo courtesy of: Gutmann, “Precast Concrete Wall Panels: Manufacturing Processes,” 50.

Form Design and Materials

Information about formwork for architectural precast wall panel materials and design was also first presented in depth at the 1965 Symposium. Good formwork was stressed as being essential to the quality of the panel, and the choice of material should consider cost, maintenance, re-use, detail, and salvageability of the form.²¹⁴ The form design was dependent upon draft allowances, desired panel texture, consolidation techniques, mass production schedules, and locally available talent.²¹⁵ Common materials used at the time of the Symposium included concrete, wood, and steel. Concrete as a form material was gaining popularity because it could accommodate numerous reuses and had minimal joints, which could produce undesirable results and remained a problem with wood and steel forms.²¹⁶ Polyester resins reinforced with glass fiber were also becoming a more popular form material.

ACI Committee 533 discussed the use of form liners to achieve various patterns and textures on the surface of the precast panel. Common materials included rubber matting, wood, vacuum-formed plastic sheets, and polyethylene film laid over uniformly distributed cobblestone [Figure 27].²¹⁷ The Committee cautioned that wood liners needed to be sealed to prevent excessive loss of moisture from the facing concrete, and architects and engineers were reminded that glossy-surface concrete should not be exposed to the exterior.

²¹⁴ Hanson and Jenny, "Precast Concrete Panels: Materials and Tests," 26.

²¹⁵ Gutmann, "Precast Concrete Wall Panels: Manufacturing Processes," 48.

²¹⁶ Geoffrey A. Collens, "Precast Concrete Wall Panels: Architectural Commentary," *Symposium on Precast Concrete Wall Panels*, ACI Publication SP-11 (1965), 116.

²¹⁷ Hanson and Jenny, "Precast Concrete Panels: Materials and Tests," 27.

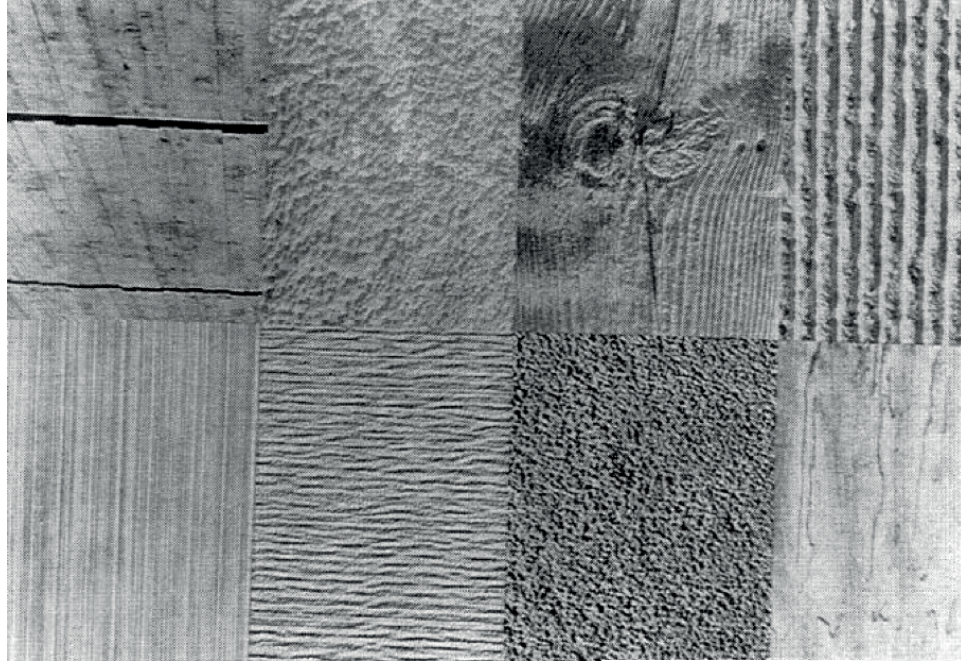

Figure 27. Images of different textures that can be achieved with the use of form liners.²¹⁸

Casting and Consolidation

At the 1965 Symposium, ACI Committee 533 explained that the most popular method of casting architectural precast wall panels was in a horizontal position with the facing concrete poured first, followed by the backup concrete, the same method developed by the Earley Studio. The Committee also recognized alternative methods, such as pouring the facing concrete on top of the backup concrete, which was the preferred casting method for panels finished with a broom.²¹⁹ To achieve a specific architectural expression, the decorative aggregate of the facing concrete may be placed first, followed by the facing concrete's cement matrix, which would then be consolidated in the form, with care taken to not disturb the location of the aggregate [Figure 28].²²⁰ Committee 533 discussed the

²¹⁸ Photo courtesy of: ACI Committee 533, *Guide for Precast Concrete Wall Panels*, 32.

²¹⁹ Hanson and Jenny, "Precast Concrete Panels: Materials and Tests," 23.

²²⁰ Gutmann, "Precast Concrete Wall Panels: Manufacturing Processes," 49.

different methods of consolidation: external vibration, internal vibration, and the method of concrete consistency variation (in which consolidation is achieved by laying progressively drier mixes to accommodate a high slump facing concrete), as well as the invention of shocked concrete and its potential for creating well-consolidated panels.²²¹



Figure 28. A precaster hand laying the facing aggregate in the formwork.²²²

In addition to the form liners used to create different textures, the facing aggregate could be exposed during casting with the use of chemical retarders; could be sprayed or brushed onto the surface of the form or a retarder-impregnated material could be placed on the form's surface before the facing concrete was placed.²²³ The Committee recommended that after the panel was cured, a mild wash of 5 to 10 percent muriatic acid be applied to its

²²¹ Photo courtesy of: Gutmann, "Precast Concrete Wall Panels: Manufacturing Processes," 51.

²²² Gutmann, "Precast Concrete Wall Panels: Manufacturing Processes," 50.

²²³ *Ibid.*, 48.

surface to clean and brighten the colored aggregate; the surface should be flushed with water immediately after the acid wash. To achieve deep reveals, the Symposium recommended the use of sand to create positive forms for the panels.²²⁴

Curing, Stripping, and Storage

Curing methods were not described in detail at the 1965 Symposium, although Committee 533 warned that panels should only be removed after sufficient strength gain and be immediately set up against a framing system. Stripping usually occurred eighteen hours after casting, but the timing was truly dependent upon the type of panel face, the desired degree of aggregate exposure, the ambient temperature of the plant, the water-cement ratio of the concrete, and the curing techniques employed.²²⁵ Committee 533 also underlined the importance of the precaster's experience in determining the timing of stripping.

Surface Treatments

At the Symposium, Committee 533 recognized that exposed aggregate was the most popular surface finish for architectural precast wall panels, although it also discussed other surface finishes briefly. The most common surface treatments to expose the facing aggregate were hand brushing, applying powered rotary brushes, bush hammering, grinding, sandblasting, or acid etching [Figure 29].²²⁶ To brighten the aggregates, Committee 533 recommended that all of these surface treatments be followed by an acid washing three to seven days after casting. It also emphasized the need to make mock ups for all surface

²²⁴ Ibid.

²²⁵ Ibid., 52.

²²⁶ Ibid.

finishes, whether achieved during the casting process or through surface treatments, to confirm that the aesthetic achieved complied with the vision of the architect and engineer of the project.²²⁷

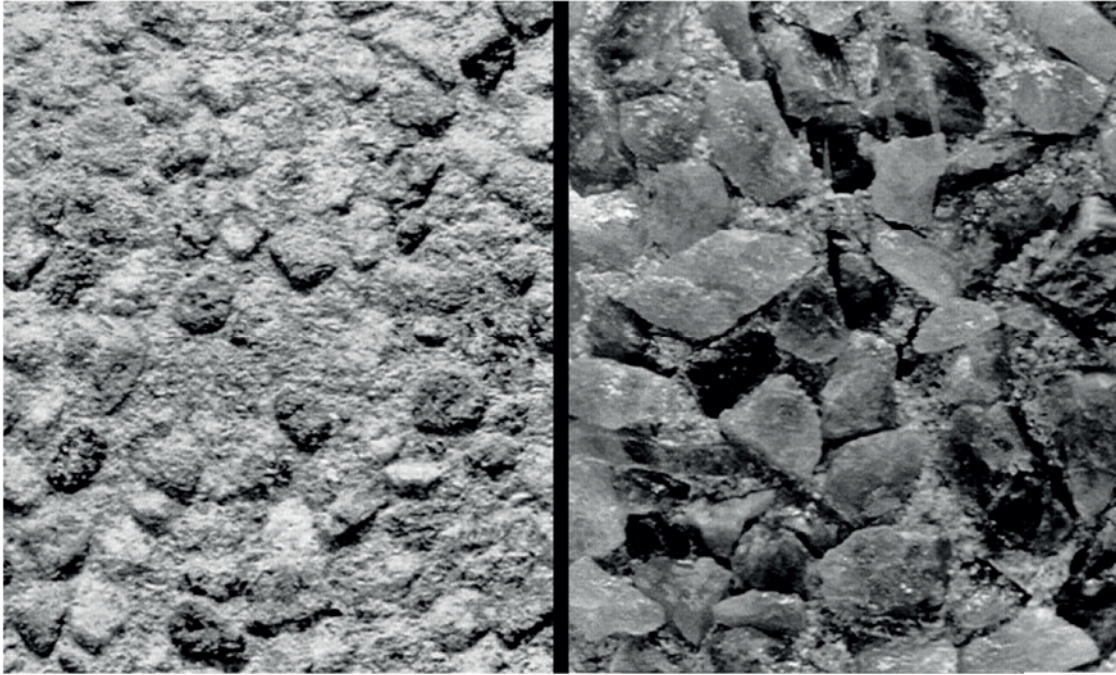

Figure 29. Comparison of different methods of exposing the facing aggregate: on the left, the aggregate is exposed using surface retarders on the form, while on the right, the aggregate is exposed after curing using sandblasting equipment.²²⁸

²²⁷ Ibid.

²²⁸ Photo courtesy of: ACI Committee 533, *Guide for Precast Concrete Wall Panels*, 37-38.

Transport, Handling, and Erection

At the Symposium, Committee 533 gave minimal attention to considerations of transporting panels between the precasting facility and the job site, although it did recommend that inserts used for lifting devices during fabrication or erection be designed for 100 percent impact.²²⁹ The Committee also discussed the problem of breakages during handling, which delayed the construction process, and highlighted the continued need to balance the abilities of the handling equipment with the size of the panel and the desire to reduce the number of joints in the wall system.²³⁰ To increase efficiency on the construction site and minimize the potential for miscommunication, Committee 533 encouraged the reduction of the number of trades involved in the erection process.²³¹

Connection Design and Materials

The Symposium outlined the various loads that connection design should consider, including wind loads with equal positive and negative pressures.²³² This latter recommendation recognized the significant load that suction caused by wind could impart on the panel connections. To protect connection materials against corrosion, Committee 533 began recommending the use of materials treated to resist corrosion, such as galvanized steel. Connections, anchors, and inserts must also be made of sufficiently ductile materials to allow for limited panel movement caused by shrinkage and moisture and temperature changes so that there would be visible deformation before fracture.²³³ Finally, Committee 533 presented specific concerns about welded connections, namely that welded

²²⁹ Leabu, "Precast Concrete Wall Panels: Design Trends and Standards," 44.

²³⁰ Collens, "Precast Concrete Wall Panels: Architectural Commentary," 116.

²³¹ *Ibid.*, 90.

²³² Leabu, "Precast Concrete Wall Panels: Design Trends and Standards," 39.

²³³ *Ibid.*, 44.

connections need to provide adequate tolerances, the connections must be detailed in such a way as to allow space for easy welding, and scorch marks on the finished surface of the panel from field welding connections must be avoided.²³⁴ At the time of the Symposium, Committee 533 gave no consideration to how welded connections could be protected from corrosion.

Joint Design and Materials

Specific joint materials and their advantages and disadvantages were discussed in the 1965 Symposium. For example, cement mortars should be avoided because they cannot accommodate the movement of the panels.²³⁵ Committee 533 promoted the use of mastics and thermosetting plastics because they can accommodate movement much better, although mastics had a short service life while thermosetting plastics generally performed better and required less maintenance.²³⁶

Cleaning, Repairs, and Coatings

The success of protective coatings was contentious at this time, for testing indicated that coatings did not, in fact, increase the panels' resistance to moisture penetration and, therefore, frost action. Instead, experience revealed that coatings made it more difficult to repair the face of the panel and could discolor the panel significantly, although they did make cleaning the panels' surface easier.²³⁷

²³⁴ Collens, "Precast Concrete Wall Panels: Architectural Commentary," 117.

²³⁵ Hanson and Jenny, "Precast Concrete Panels: Materials and Tests," 28.

²³⁶ Ibid.

²³⁷ Ibid.

Testing

Testing remained an important issue, and at the Symposium, Committee 533 recommended the same 6x12 in. cylinder and 4 in. cube sample sizes that it originally proposed in its 1964 article for compressive strength tests. The Committee also recommended a vibration test (ASTM C31 and C192) for low slump or zero-slump concrete.²³⁸ Durability tests continued to be considered unnecessary due to the infrequency of panel saturation, but Committee 533 recognized that a test or method to detect facing aggregate with a sufficient iron content to stain the surface of the panel needed to be developed because that amount was untraceable through conventional tests.²³⁹

Bowing and Warpage

Finally, bowing and warpage continued to be a significant problem and was addressed extensively in the 1965 Symposium. The results of various investigations were presented in the Symposium, including the fact that panels “always deflect outward regardless of whether the temperature is higher or lower inside than outside, whether the panel is solid or sandwiched, or whether the panel is cast face down for the exposed aggregate panels or cast face up for the regular concrete broomed surface.”²⁴⁰ Committee 533 also found that the following contributed to the problem of bowing: larger panel sizes, the curing position in the yard, temperature and moisture differential across the cross-section of the panel, and differential shrinkage of the facing and backup concrete mixes.²⁴¹ This section of the Symposium warned against the use of intermediate connections to

²³⁸ Ibid., 21.

²³⁹ Ibid., 23.

²⁴⁰ Sheng, “Precast Concrete Wall Panels: Bowing, Warpage, and Movement,” 62.

²⁴¹ Ibid., 58.

control deflection, however, because a concentration of stresses could occur at these points and result in the development of visible cracks.²⁴²

1965-1975: MOMENTUM IN THE ARCHITECTURAL PRECAST INDUSTRY

1965 became a pivotal year for the architectural precast panel industry due to the significant impact of the Symposium. The influence of the Symposium is evidenced by the numerous organizations that were established immediately afterwards to promote the use of architectural precast wall panels and improve their production and quality, including the National Precast Concrete Association, which was founded in 1965, and the Architectural Precast Association, which was founded in 1966.²⁴³ What was then known as the Prestressed Concrete Institute (PCI) added precast to its mission in 1966 and created the Plant Production of Architectural Precast Concrete Products Committee to “introduce a plant certification program for architectural precast concrete productions” to contribute to the quality assurance of this concrete technology.²⁴⁴ The PCI Committee wanted to publish a manual for guidance on quality control, plant facilities, materials, production, erection, and creation of samples, all the while recognizing the challenge of balancing recommended standards with the diverse needs of individual plant operations resulting from the many geographical locations and circumstances of precast production.²⁴⁵ Through its numerous publications, the PCI Committee and its members’ contribution to the design, production, and assembly of architectural precast wall panels was second only to ACI Committee 533’s contribution.

²⁴² Ibid., 62.

²⁴³ “About NPCA: Our Mission,” NPCA, last accessed 7 March 2016, <http://precast.org/npca/>; “About Us,” APA, last accessed 7 March 2016, <http://www.archprecast.org/index.php/about-us#history>.

²⁴⁴ John F. Downing, “A Manual for Quality Control,” *PCI Journal* (April 1968): 58.

²⁴⁵ Ibid.

Design Objectives

After ACI Committee 533's 1965 Symposium, the design objectives for precast panels became more nuanced, emphasizing the significance of stresses induced during handling and the relationship between the panel units and the structural frame.²⁴⁶ Particularly because of the stresses imposed on the panels during handling, high compressive strengths in excess of service requirements were recommended.²⁴⁷ Conveniently, such high strengths enabled the "more satisfactory attainment of architectural finishes."²⁴⁸ C.H. Raths, a member of the PCI Committee, also highlighted the importance of designing the shape of the panel to accommodate all of the different stages of handling, including stripping from the form.²⁴⁹ After the 1965 Symposium, the first factors of safety were recommended: the panel should be designed with a factor of safety of 2.5, inserts used in handling should be designed with a factor of safety of 4, and connections should be designed with a factory of safety of at least 3.²⁵⁰

Durability remained a primary concern after the Symposium, particularly that of the facing concrete, although the perception from the early 1960s, that the vertical position of the panel would reduce the potential for saturation and therefore freeze-thaw damage, persisted. In 1967, an article published by Raths explicitly established the production of crack-free panels as a primary goal in panel design. He proposed that this goal could be achieved through high compressive strengths and successful reinforcement design.²⁵¹

²⁴⁶ C.H. Raths, "Production and Design of Architectural Precast Concrete," *PCI Journal* (June 1967): 19; C.H. Raths, "Engineering Design of Architectural Precast Concrete," *PCI Journal* (April 1968): 83.

²⁴⁷ Victor F. Leabu and J.A. Hanson, "Quality Standards and Tests for Precast Concrete Wall Panels," *ACI Journal* (April 1969): 271.

²⁴⁸ *Ibid.*

²⁴⁹ Raths, "Engineering Design of Architectural Precast Concrete," 78.

²⁵⁰ *Ibid.*, 81; Richard C. Adams and Victor Leabu, "Design of Precast Concrete Wall Panels," *ACI Journal* (July 1971): 513; *Ibid.*, 512.

²⁵¹ Raths, "Production and Design of Architectural Precast Concrete," 29.

At the beginning of the 1970s, there was an increasing concern for coordinating tolerances to ensure successful panel design and joint system design, including the tolerances between panels and adjacent materials, between panels and the building frame, and for panel movement.²⁵² A 1971 publication by ACI Committee 533 revealed a new appreciation for the potential variety of eccentricities imposed on the panel from support, connection, line of load applications, variations in flatness, unsymmetrical cross-sections, total deflection, etc.²⁵³ Consequently, Committee 533 recommended that these loads become a primary consideration in the panel design.

By 1975, there was still no standard published by ACI nor a universal specification to guide the design, production, and assembly of architectural precast wall panels. The lack of such a standard or universal specification resulted from the fact that techniques continued to vary greatly among reliable manufacturers—a fact that reveals the continued significance of craftsmanship to this industry.²⁵⁴ Determining the optimal balance of economical and practical to achieve the required strength, durability, volume constancy, surface finish, and workability relied on both the experience of precasters and calculations and tests.²⁵⁵

Material Selection

In the years following the 1965 ACI Symposium, concerns about reducing color variations between panels and increasing durability continued to orient the recommendations for materials. For example, Fay Lawson, a member of the PCI Committee, revealed that white cement was problematic because it was more easily stained by the

²⁵² Leabu and Adams, "Fabrication, Handling and Erection of Precast Concrete Wall Panels," 327.

²⁵³ Adams and Leabu, "Design of Precast Concrete Wall Panels," 506.

²⁵⁴ Leabu and Adams, "Fabrication, Handling and Erection of Precast Concrete Wall Panels," 313.

²⁵⁵ *Ibid.*, 320.

forms.²⁵⁶ ACI Committee 533 recommended that aggregates vulnerable to weathering/deterioration should be avoided to reduce discoloration.²⁵⁷ Additionally, natural sand and gravel aggregates were recommended for having less shrinkage and producing more workable concrete, although crushed aggregate was recognized to have a greater bond with cement paste and better aggregate interlock.²⁵⁸

ACI Committee 533 added to their recommendations about admixtures in the years following the 1965 Symposium. They recommended in 1969 a “normal” amount of air-entraining agent, or a dosage that would provide $19 \pm 3\%$ air in a 1:4 (cement to sand by weight) standard sand mortar, although there continued to be deference to the variety of mixtures used in the production of architectural precast wall panels.²⁵⁹ In 1969, Committee 533 continued to recommend using Type III cement and good curing methods over accelerating admixtures to achieve high early strength, but it advised against the use of retarding admixtures to prolong workability.²⁶⁰ In the same article, the Committee recommended the use of water-reducing admixtures to reduce bleeding water or increase workability, but only if adequate consolidation could be achieved.²⁶¹ Mineral admixtures and pozzolans could be used to obtain a smooth concrete surface, and by the late 1960s, it was recognized that not only did pigment amounts exceeding 5% not add to the intensity of the color of the concrete, but amounts above 10% could be harmful to the concrete mix.²⁶²

²⁵⁶ Lawson, “Panel Discussion on Production and Quality Control for Architectural Precast Concrete,” 70.

²⁵⁷ Leabu and Hanson, “Quality Standards and Tests for Precast Concrete Wall Panels,” 271.

²⁵⁸ Victor F. Leabu and Daniel P. Jenny, “Selection and Use of Materials for Precast Concrete Wall Panels,” *ACI Journal* (October 1969): 815.

²⁵⁹ Leabu and Hanson, “Quality Standards and Tests for Precast Concrete Wall Panels,” 274; Leabu and Adams, “Fabrication, Handling and Erection of Precast Concrete Wall Panels,” 320.

²⁶⁰ Leabu and Jenny, “Selection and Use of Materials for Precast Concrete Wall Panels,” 816.

²⁶¹ *Ibid.*, 817.

²⁶² *Ibid.*

Mixing

The process of mixing the various ingredients of the facing and backup concrete was not discussed at length in any publication until the 1970s. One of the 1970s documents published by ACI Committee 533 in preparation for a standard dedicated to architectural precast wall panels highlighted the fact that within the precast industry there was an immense amount of variety in mixing procedures.²⁶³ In the never-ending attempt to ensure the quality of the architectural precast wall panel product, the Committee recommended only a handful of rules that should be followed to achieve desirable results:

- The mixer should only be operating while all materials are charged;
- To obtain a homogeneous mix, after all the materials have entered the mixer, they should be mixed for a minimum of 1 minute or as recommended by the mixer manufacturer;
- If, due to cold weather, the aggregate or water has been heated, cement should be added only after the aggregate and water have entered the mixer and have been thoroughly mixed for at least 1 minute;
- Lightweight aggregates should be pre-wetted; and,
- The mixer should be properly loaded—not above capacity—and thoroughly cleaned after each period of production.²⁶⁴

²⁶³ Leabu and Adams, "Fabrication, Handling and Erection of Precast Concrete Wall Panels," 321.

²⁶⁴ *Ibid.*

Reinforcement Design and Materials

After the Symposium, more attention was given to the design and placement of reinforcement. To prevent bending, the PCI Committee recommended that reinforcement be centered in the cross section rather than at the facing and backup concrete interface.²⁶⁵ In 1967, PCI recommended a more conservative 1 in. cover over all steel reinforcement, while ACI Committee 533 recommended a cover of a ½ in. in a 1969 publication, an increase from the 3/8 in. recommended in the 1965 Symposium.²⁶⁶ Both organizations recommended using galvanized reinforcement in scenarios where the cover was the minimum recommended cover or less. The types of reinforcement used in architectural precast panels appears to have expanded greatly after the 1965 Symposium and included billet-steel, rail-steel, and axle-steel deformed bars; high tensile strength steel wires, rods, and strands for prestressing purposes; or as-drawn or galvanized welded wire fabric, smooth or deformed, with a variety of mesh spacings and wire gages.²⁶⁷ PCI advised that the reinforcement must be designed to accommodate the stresses induced by stripping, handling, storage, shipping, erecting, and wind and other in-place loads.²⁶⁸

By 1975, there was heightened attention to the causes of reinforcement corrosion. In 1970, ACI Committee 533 recognized that corrosion could be caused by inadequate quality of concrete due to improper mix proportioning, improper consolidation of concrete, inadequate cover by design or misplacement of reinforcement, excessive use of calcium chloride, or a combination of these factors.²⁶⁹ As a result, they recommended the use of welded wire fabric to achieve better cover, the use of galvanized reinforcement when the recommended minimum cover (½ in. according to ACI and 1 in. according to PCI) could not

²⁶⁵ Raths, "Production and Design of Architectural Precast Concrete," 30.

²⁶⁶ Ibid.; Leabu and Jenny, "Selection and Use of Materials for Precast Concrete Wall Panels," 817.

²⁶⁷ Leabu and Jenny, "Selection and Use of Materials for Precast Concrete Wall Panels," 817.

²⁶⁸ Raths, "Production and Design of Architectural Precast Concrete," 19.

²⁶⁹ Leabu and Adams, "Fabrication, Handling and Erection of Precast Concrete Wall Panels," 321.

be achieved, and the importance of accurately placing reinforcement.²⁷⁰ Additionally, to control cracking in panels less than 6 in. thick, Committee 533 proposed placing at least two layers of reinforcement and placing additional reinforcement along the edges of the panel and around any openings in the panel.²⁷¹ Significantly, in 1970, Committee 533 increased its recommended minimum cover from ½ in. (presented in 1969) to ¾ in. and recognized the need to consider the environment to which the concrete surface was exposed, including whether it was exposed to ocean atmosphere or aggressive industrial fumes, to determine the appropriate amount of cover.²⁷²

Form Design and Materials

Wood, steel, concrete, and fiber-glass-reinforced plastics continued to be the most popular form materials, while molds of plaster, gelatin, or sculptured sand were used for more complicated details.²⁷³ According to ACI Committee 533, fiber-glass-reinforced plastic forms had the best overall performance, but they had to be well supported along edges and flat areas to prevent form distortion due to the flexibility of the plastic.²⁷⁴ Concrete forms had excellent rigidity and dimensional stability and allowed for numerous reuses, although care had to be taken during stripping. To improve the form release and facilitate stripping, the form could be treated with epoxy or other plastic resins.²⁷⁵ Wood forms tended to show their wear and tear more quickly than the other form materials and had to be treated to prevent excessive absorption and nonuniform finish. Steel molds were more difficult to modify and obtain dimensional control, although they were good for multiple assemblies

²⁷⁰ Ibid., 322.

²⁷¹ Adams and Leabu, "Design of Precast Concrete Wall Panels," 511.

²⁷² Leabu and Adams, "Fabrication, Handling and Erection of Precast Concrete Wall Panels," 321.

²⁷³ Raths, "Production and Design of Architectural Precast Concrete," 19.

²⁷⁴ Leabu and Adams, "Fabrication, Handling and Erection of Precast Concrete Wall Panels," 318.

²⁷⁵ Ibid.

and disassemblies.²⁷⁶ For all forms, a dimensional tolerance of $\pm 1/8$ in. was proposed by PCI.²⁷⁷ Additionally, form liners continued to be a primary way of obtaining patterns and textures on the surface of architectural precast panels, although there was caution against the use of some liners, such as rubber matting, for they could stain or discolor the panel surface.²⁷⁸

Casting and Consolidation

The desire to give deference to precasters and their methods of production appears to have continued well after the Symposium, for little information about the casting process was presented in the publications from between 1965 and 1975. Still, in its 1970 publication, ACI Committee 533 presented important considerations for the form design to ensure high quality during casting: the form should achieve recommended casting tolerances by being sufficiently rigid, prevent leakage of the mortar or cement paste by being sufficiently tight, and prevent damage to the concrete from panel shrinkage and stripping.²⁷⁹ Consolidation was still achieved through external vibration, internal vibration, or the adjusted slump and mix method.²⁸⁰

Surface Finishes and Treatments

Documents published during this period by PCI in particular emphasized the importance of effective communication between precasters, architects, and engineers,

²⁷⁶ Ibid.

²⁷⁷ Raths, "Production and Design of Architectural Precast Concrete," 20.

²⁷⁸ Leabu and Jenny, "Selection and Use of Materials for Precast Concrete Wall Panels," 817.

²⁷⁹ Leabu and Adams, "Fabrication, Handling and Erection of Precast Concrete Wall Panels," 317.

²⁸⁰ Ibid., 323.

especially for obtaining the desired surface appearance.²⁸¹ The types of surface finishes and treatments did not change immensely after the 1965 Symposium, however, although publications presented the range of finishes, applied either to plastic concrete during casting or hardened concrete after curing and stripping:

- Plastic Concrete
 - Chemical surface retarders;
 - Brooming;
 - Floating or troweling;
 - Special form finishes; and,
 - Scrubbing, brushing, and surface texture;
- Hardened Concrete
 - Hand brushing and/or power rotary brushes;
 - Belt sanding;
 - Acid etching;
 - Sand or other abrasive blasting;
 - Honing and polishing;
 - Bush hammering or other mechanical tooling; and,
 - Artificially created broken rib texture.

Considerations about how surface finishes and treatments related to other parts of the production and assembly process became more significant after the 1965 ACI Symposium. For example, ACI Committee 533 advised that the choice of surface finish or

²⁸¹ Richard E. Cavanaugh, "Contractor Considerations for Architectural Precast Concrete," *PCI Journal* (April 1968): 85.

treatment must consider the handling requirements of the panels. Additionally, while gap-graded facing aggregates continued to be preferred for exposed aggregate finishes, Committee 533 found that using a grade of aggregates with a more restrictive size limitation could improve both the uniformity of the surface and its durability due to less segregation and better contact between the aggregate and matrix.²⁸² Information about what to avoid also became more prominent. For instance, ACI Committee 533 warned that glass aggregates used to create bright colors could possibly react with cement and cause problems.²⁸³ The Committee recognized that acid etching must be used with caution because of the potential for the acid to react with the facing aggregate or cement, resulting in the build up of calcium silicate deposits on the surface of the panel.²⁸⁴ Acid etching could also potentially damage galvanized reinforcement without sufficient cover. Similarly, the Committee advised that the compressive strength of blasting equipment used to expose the facing aggregate, such as sandblasting, must be considered to ensure the adequate cover and protection of the reinforcement.

Curing, Stripping, and Storage

Curing in the form, which usually occurred for one day, had to be highly controlled to prevent excessive evaporation, which could create tensile stresses at the surface of the panel and cause cracking. Due to the use of high early strength cement or high Type I cement contents, ACI Committee 533 identified the initial curing in the form as being the most important.²⁸⁵ In contrast, the curing that occurred after form stripping had to compete

²⁸² Leabu and Adams, "Fabrication, Handling and Erection of Precast Concrete Wall Panels," 319.

²⁸³ Leabu and Jenny, "Selection and Use of Materials for Precast Concrete Wall Panels," 816.

²⁸⁴ *Ibid.*, 324; Leabu and Jenny, "Selection and Use of Materials for Precast Concrete Wall Panels," 818.

²⁸⁵ Leabu and Adams, "Fabrication, Handling and Erection of Precast Concrete Wall Panels," 325.

with the needs of the surface treatments employed.²⁸⁶ The basic methods of curing included supplying additional moisture (immersion, sprinkling, or wet coverings), prevention of moisture loss (waterproof paper or plastic sheets), or acceleration of strength gain through the addition of heat.²⁸⁷ Although the initial curing phase was the most significant for strength gain, Committee 533 still recommended that the panels be protected from excessive evaporation or temperatures below 50°F after stripping and surface treatments.²⁸⁸

Form stripping became a primary concern after the 1965 Symposium, and publications acknowledged the stresses that the process could impose on the panel and the potential damage it could cause. PCI warned that cracking could occur during stripping due to either thermal shock or mishandling.²⁸⁹ PCI also identified shrinkage of the unit, form suction, and staining of the unit during form release as being significant problems.²⁹⁰

Essential to the stripping, handling, and erection process was the placement of handling inserts in the panels. Such inserts could be bolted to the panels, which PCI claimed in 1967 was the most common practice, or wire cable inserts could be cast into the panel.²⁹¹ Testing indicated that such inserts had a greater capacity when loaded in pure shear than when loaded in direct tension. Fortunately, many insert manufacturers could provide useful test information about their products.²⁹²

Finally, much more information about the storage of panels was presented after the 1965 Symposium due to its acknowledged connection to panel bowing and warpage. In a

²⁸⁶ Ibid.

²⁸⁷ Ibid.

²⁸⁸ Ibid., 326.

²⁸⁹ Raths, "Production and Design of Architectural Precast Concrete," 20.

²⁹⁰ A.A. Roy, "Panel Discussion on Architectural and Engineering Design of Architectural Precast Concrete," *PCI Journal* (April 1968): 92; Lawson, "Panel Discussion on Production and Quality Control for Architectural Precast Concrete," 70.

²⁹¹ Raths, "Production and Design of Architectural Precast Concrete," 26.

²⁹² Raths, "Engineering Design of Architectural Precast Concrete," 82.

1967 article, PCI recommended that units always be supported at only two points and with proper blocking in a given plane to avoid distortion.²⁹³ ACI Committee 533 advised that storage conditions, even on the job site, must prevent soiling, as well as the rapid loss of moisture and freezing, which could cause deflection.²⁹⁴ To minimize handling, and therefore breakages, the storage of the panels should consider how the units would ultimately be transported.²⁹⁵

Transport, Handling, and Erection

PCI recommended that panels be supported only at two points during transport and in all handling actions to avoid distortion.²⁹⁶ During shipping, which typically occurred by semitrailer trucks over highways, ACI Committee 533 advocated that panels be loaded vertically, supported on 'A' frames, and stored in such a way as to protect against road shock.²⁹⁷ The Committee also proposed that panels should always be handled in a vertical position and all handling should occur in midair to avoid damaging the panels.²⁹⁸

Connection Design and Materials

After the 1965 Symposium, information about connections became very prominent in publications because of their significance in the performance of architectural precast wall panel systems. The types of connections utilized in panel wall systems included clip angles, slotted inserts, bolts, or concrete haunches cast onto the back of the panels.²⁹⁹ Connections

²⁹³ Raths, "Production and Design of Architectural Precast Concrete," 21.

²⁹⁴ Leabu and Adams, "Fabrication, Handling and Erection of Precast Concrete Wall Panels," 326 and 331.

²⁹⁵ Raths, "Production and Design of Architectural Precast Concrete," 21.

²⁹⁶ Ibid.

²⁹⁷ Leabu and Adams, "Fabrication, Handling and Erection of Precast Concrete Wall Panels," 330.

²⁹⁸ Ibid.

²⁹⁹ Ibid., 333.

could be made from steel, pressed steel, or malleable cast iron.³⁰⁰ To adequately accommodate lateral movement, PCI proposed ½ in. as a practical dimensional tolerance in 1967.³⁰¹ In a 1968 publication, PCI promoted the standardization of connections for a given project to increase construction efficiency.³⁰² To similarly increase efficiency, ACI Committee 533 recommended in 1970 that connections be designed to allow for adjustment in the field, easy access during erection, fast securement, and limited panel movement after installation.³⁰³

Numerous specific recommendations about connection design were presented after the 1965 Symposium. For instance, both PCI and ACI Committee 533 proposed that good connection design involved supporting panels at one level—or only two points—to keep the panel cross-section in compression, and, ideally, locating the main panel support fairly close to the bottom edge of the panel to allow for proper bolting and a positive seating, rather than hanging the panel from connection angles and clamps [Figure 30].³⁰⁴ The design of connections should also attempt to minimize the transfer of building loads to the wall panel and the development of restraint forces resulting from temperature changes, wind, or gravity loads.³⁰⁵

³⁰⁰ Victor F. Leabu, “Connections for Precast Concrete Wall Panels,” *ACI Paper SP 22-8* (1969): 98.

³⁰¹ Raths, “Production and Design of Architectural Precast Concrete,” 33.

³⁰² Raths, “Engineering Design of Architectural Precast Concrete,” 79.

³⁰³ Leabu and Adams, “Fabrication, Handling and Erection of Precast Concrete Wall Panels,” 333.

³⁰⁴ *Ibid.*, 30; Leabu, “Connections for Precast Concrete Wall Panels,” 101.

³⁰⁵ Raths, “Engineering Design of Architectural Precast Concrete,” 79.

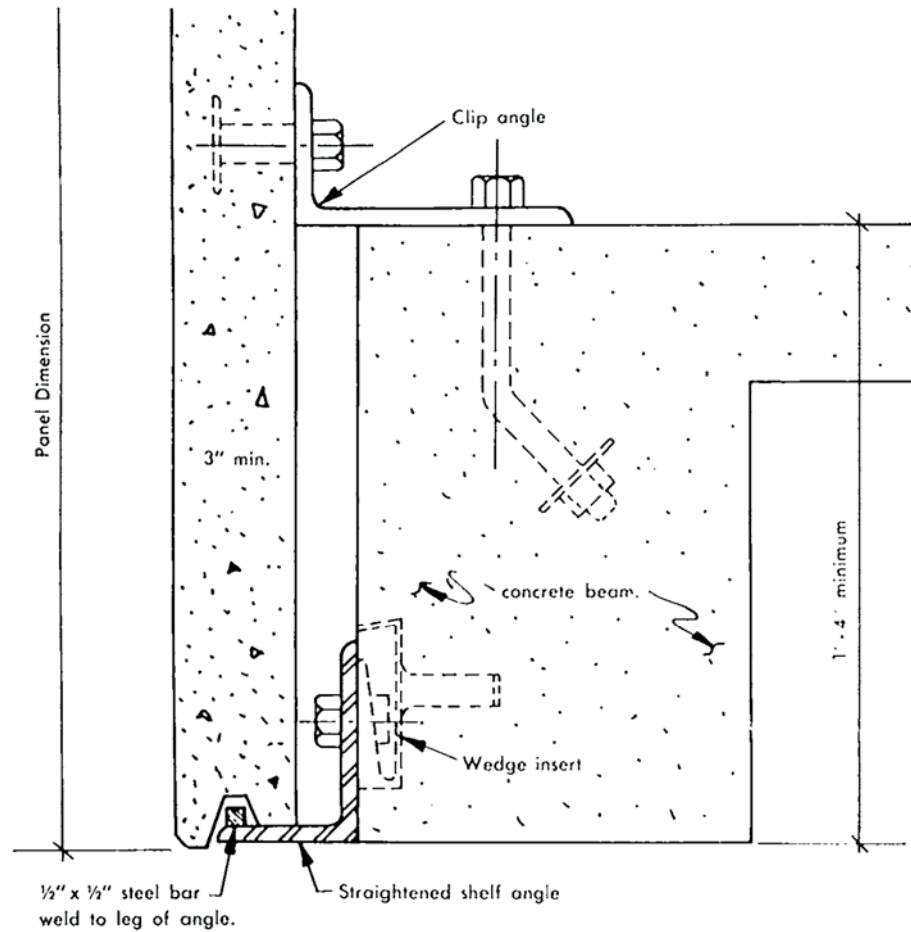

Figure 30. Example of a positive seating connection between an architectural precast wall panel and a concrete frame.³⁰⁶

The materials used for connections should be permanently ductile to accommodate panel movement, and publications stressed the importance of avoiding coatings that could cause embrittlement of the material. The vulnerability of connection materials to long-term corrosion despite their lack of exposure to the exterior environment finally began to be appreciated, which resulted in an increasing use of stainless steel, galvanized materials, or cadmium plated materials. Significantly, stainless steel was not recommended as a

³⁰⁶ Photo courtesy of: Leabu, "Connections for Precast Concrete Wall Panels," 100.

connection material until ACI Committee 533's 1969 article about precast panel connections.³⁰⁷ Problems with welded connections also began to be appreciated after the 1965 Symposium. In 1968, PCI highlighted the discovery that welded connections could have reduced capacity when exposed to exterior temperatures below 0°F, and in 1969, ACI Committee 533 warned that the high heat from welding could cause damage to the panel and/or supporting concrete frame through the sudden expansion of the concrete material.³⁰⁸

Joint Design and Materials

Like with the design of connections, much more specific guidelines for the design of joints were presented after the 1965 Symposium. In 1968, PCI recognized that weatherproofing the joints between the panels and between the panels and other wall elements was essential to the performance of the wall system.³⁰⁹ To achieve successful weatherproofing, the joint material must be installed with good workmanship and be flexible to accommodate panel movement. Cement mortar, mastics, and elastomeric materials remained the primary joint materials, although PCI only recommended that cement mortars be used in situations where there would be negligible panel movement. After the Symposium, there were new developments in elastomeric materials, including thermoplastics (cold-applied, solvent, or emulsion types) and thermosetting elastomerics (chemically curing or solvent release types).³¹⁰

Joint systems could either be field-molded, which PCI claimed was preferable when the joint width and movement were nominal, or premolded, which PCI claimed was

³⁰⁷ Leabu, "Connections for Precast Concrete Wall Panels," 102.

³⁰⁸ Roy, "Panel Discussion on Architectural and Engineering Design of Architectural Precast Concrete," 93; Leabu, "Connections for Precast Concrete Wall Panels," 100.

³⁰⁹ R.J. Schutz, "Design of Joints in Precast Concrete Wall Panels," *PCI Journal* (October 1966): 60.

³¹⁰ Raymond J. Schutz, "Architectural Precast Concrete Joint Details," *PCI Journal* (March-April 1973): 25.

preferable and more economical when panel movement was severe or the joint width was exceptionally wide (greater than 1 ½ in.).³¹¹ In 1966, PCI Committee member R.J. Schutz proposed that the design of field-molded joint systems should be determined by the shape factor of the joint, or the depth-to-width ratio, with the best performing and most economical joint being as shallow as possible [Figure 31].³¹²

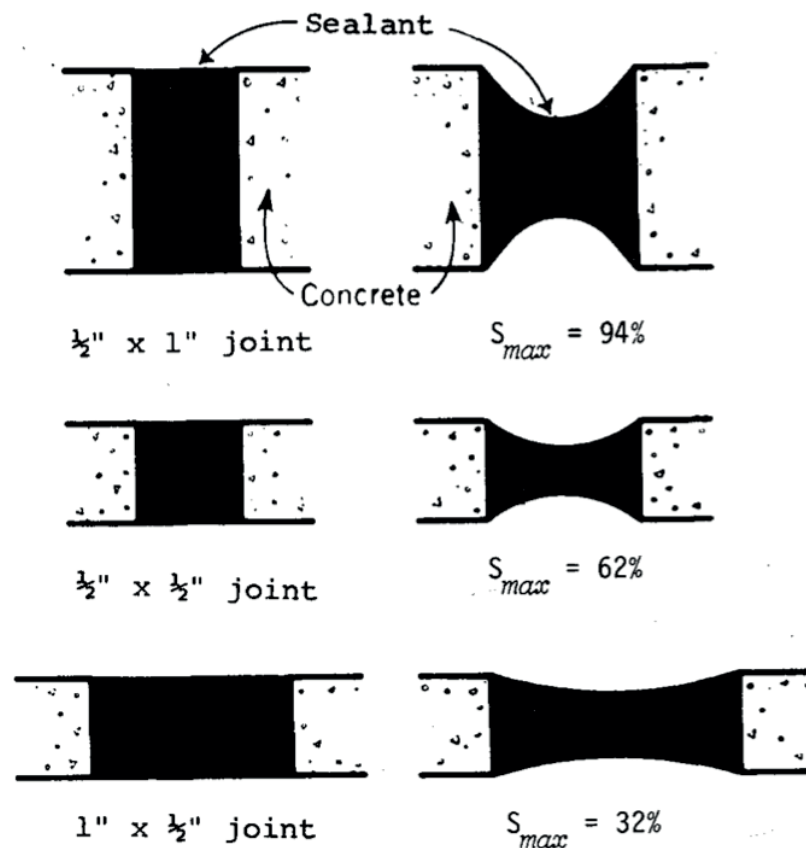

Figure 31. Comparison of the strain experienced by the sealant material in joints of different shape factors. The most shallow joint, 1" x ½" experiences the least strain, with $S_{max}=32\%$.³¹³

³¹¹ Schutz, "Design of Joints in Precast Concrete Wall Panels," 64.

³¹² Ibid., 61.

³¹³ Photo courtesy of: Schutz, "Design of Joints in Precast Concrete Wall Panels," 61.

The joint shape factor should be based on the panel size and coefficient of expansion of the panel material, and PCI recommended that ½ in. be the minimum width for any joint.³¹⁴ PCI also advised that the joint material should have a low modulus of elasticity so that it will elongate without pulling off the surface of the panel. Especially for field-molded joint systems, PCI cautioned against the potential for compression set, or the set that can occur after the joint material has been in compression and does not fully recover after release. Premolded joint systems could be constructed using sheets or tubes made from neoprene or butyl rubber, which would be bonded to the sides of the joint slots with gap-filling epoxy adhesive or non-sag field-molded sealant.³¹⁵ PCI warned that premolded joints should only be subjected to bending and flexing and not stretching to prevent joint failure.³¹⁶ For both types of joint systems, PCI recommended that care be taken to align the joints horizontally and vertically for aesthetic reasons and to guide water along the joints rather than the face of the panels. In a later publication from 1973, PCI recommended that joints be located where there was maximum panel thickness and in response to an understanding of the weather patterns for the structure.³¹⁷ To ensure their success, the joints must be properly prepared prior to the installation of the joint material, including the application of a joint primer and backup filler, which controlled the depth of the sealant and acted as a bond breaker.

Finally, during this latter period, cavity walls became more popular, adding complexity to the wall system. A primary consideration was the need to vent the cavity and ACI Committee 533 promoted the placement of vent tubes in all horizontal joints of the wall system in order to do so.³¹⁸ The two-stage rain screen joint system resulting from cavity

³¹⁴ Schutz, "Design of Joints in Precast Concrete Wall Panels," 63.

³¹⁵ *Ibid.*, 64.

³¹⁶ *Ibid.*, 66.

³¹⁷ Schutz, "Architectural Precast Concrete Joint Details," 14.

³¹⁸ Leabu and Adams, "Fabrication, Handling and Erection of Precast Concrete Wall Panels," 335.

wall design became more popular than the conventional one-stage joint system and was seen as the most effective system in separating and controlling both the exterior and interior air and humidity conditions [Figure 32].³¹⁹

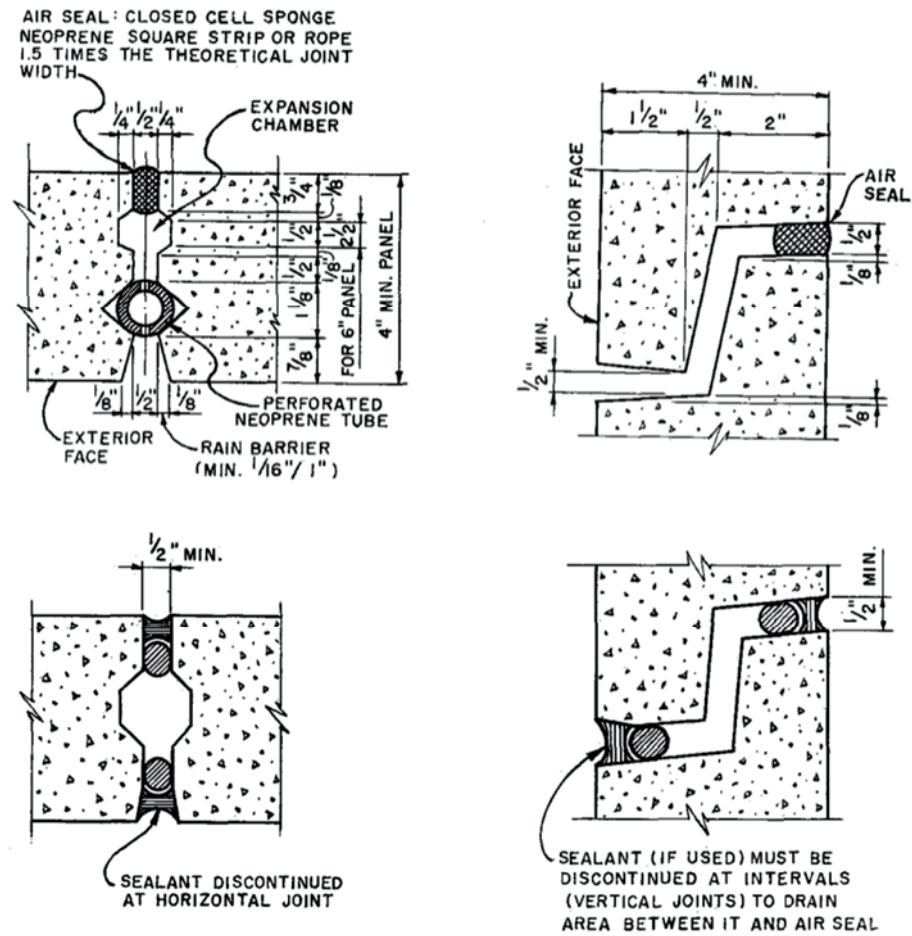

Figure 32. Examples of two-stage joint systems.³²⁰

³¹⁹ Schutz, "Architectural Precast Concrete Joint Details," 13.

³²⁰ Photo courtesy of: Schutz, "Architectural Precast Concrete Joint Details," 17.

Cleaning, Repairs, and Coatings

In 1970, ACI Committee 533 prescribed that, after installation, any excess mortar, plaster, extra shims, etc. be removed and the panels cleaned.³²¹ Cleaning could be achieved simply with soap powder dissolved in boiling water followed by a thorough rinse with clear water. For particularly difficult stains, however, ACI Committee 533 recommended the use of diluted muriatic acid or steam cleaning and sandblasting, although care should be taken with either of these methods because they could potentially alter the appearance of the panels.³²² After cleaning the panels, damage caused during handling or installation was repaired on-site. ACI Committee 533 advised that the quality of the repair was contingent on the weather and curing conditions of the repair material.³²³ Protective coatings, which would be applied after cleaning and repairs, remained controversial due to concerns about spalling of the concrete surface and discoloration of the panels.³²⁴

Testing

Although testing continued to be a concern in the years following the 1965 Symposium, few new recommendations were presented. In addition to the recommendations presented in the Symposium, ACI Committee 533 proposed in 1969 that absorption tests be adapted for the purposes of understanding the ability of architectural precast wall panels to resist dirt adherence, staining from soft aggregates, fading of colors, and other issues that could alter the panels' appearance.³²⁵ In 1968, PCI was in the process of testing different coatings to try to solve the problem of discoloration caused by their

³²¹ Leabu and Adams, "Fabrication, Handling and Erection of Precast Concrete Wall Panels," 332.

³²² Leabu and Adams, "Fabrication, Handling and Erection of Precast Concrete Wall Panels," 336.

³²³ *Ibid.*, 324.

³²⁴ Leabu and Jenny, "Selection and Use of Materials for Precast Concrete Wall Panels," 819.

³²⁵ Leabu and Hanson, "Quality Standards and Tests for Precast Concrete Wall Panels," 274.

application, although no further information about the results of this testing were presented before 1975.³²⁶

Bowing and Warpage

Bowing and warping also continued to be a significant problem. After the 1965 Symposium, additional causes were identified, including unsymmetrical panel sections and differences between facing concrete and backup concrete properties.³²⁷

CONCLUSION

The industry literature reveals how the design, production, and assembly of architectural precast wall panels changed between 1945 and 1975 and demonstrates not only the industry's desire to improve and standardize their product but also important gaps in the literature. The information presented in this chapter provides the foundation for understanding the technical aspects of this concrete technology and predicting how it could deteriorate. The results of this evaluation are presented in the following chapter.

³²⁶ Lawson, "Panel Discussion on Production and Quality Control for Architectural Precast Concrete," 73.

³²⁷ Leabu, "Connections for Precast Concrete Wall Panels," 95.

CHAPTER 6: METHODOLOGY FOR PREVENTIVE CONSERVATION OF ARCHITECTURAL PRECAST WALL PANELS

INTRODUCTION

Understanding the historical and architectural significance of architectural precast wall panels is essential to their preservation, for such understanding will lead to heightened awareness and ultimately greater appreciation for this concrete technology. Still, this thesis seeks to also contribute to the physical conservation of architectural precast wall panels by identifying potential threats that may affect them. These threats were identified by analyzing the technological evolution of architectural precast wall panels (Chapter 5) within the context of reinforced concrete pathologies and the current understanding of how architectural precast wall panels deteriorate presented in the literature review (Chapter 4). The data and results of this evaluation are presented below, to be used in the creation of preventive conservation plans.

METHODOLOGY PART 1—CATEGORIZING INDUSTRY LITERATURE

The primary consideration for the preservation of architectural precast wall panels is preventing or reducing the amount of cracking. Cracking not only makes panels more susceptible to subsequent deterioration, but also negatively affects the appearance of this architectural feature and can lead to spalling and loss of original fabric. To prevent such deterioration, the particular vulnerabilities of architectural precast wall panels due to their design, production, and assembly must be identified. The specific recommendations and guidance from the documents discussed in Chapter 5 can provide us with this information.

DATA

The information derived from this methodology is organized into tables [Tables 1-11] based on the following subjects:

- Design Objectives [Table 1]
- Material Selection [Table 2]
- Reinforcement Design and Materials [Table 3]
- Form Design and Materials [Table 4]
- Casting and Consolidation [Table 5]
- Surface Finishes and Treatments [Table 6]
- Curing, Stripping, and Storage [Table 7]
- Transport, Handling, and Erection [Table 8]
- Connection Design and Materials [Table 9]
- Joint Design and Materials [Table 10]
- Cleaning, Repairs, and Coatings [Table 11]

Within each subject table, the recommendations are further organized into sub-categories. For example, within the “Materials” category, the information is organized into general information about materials, information about cement, information about aggregates, and information about admixtures. Additionally, the information is presented with respect to the time period of its publication, divided into four periods: pre-1965 ACI Symposium, 1965 ACI Symposium, 1965-1969, and 1970-1975. Finally, the individual recommendations are classified based on whether they are indicative of general trends in the industry, technical guidance, or standards, and they are color coded as follows:

Trend: information about general trends in a given category.

Technical Guidance: recommendation or information that provides technical guidance to precasters, architects, engineers, or contractors.

Standard: recommendation or information that provides a standard for some element of the design, production, or assembly of architectural precast wall panels; typically, these recommendations or information are associated with the presentation of specific dimensions, such as minimum cover over reinforcement.

There are some assumptions and simplifications that must be addressed in evaluating these recommendations and guidance, however. First, an important simplification in reading the tables is that the first period in which information about a particular topic is presented indicates that no information in previous periods was presented about that topic. For example, in “Design Objectives,” a standard for the minimum compressive strength of the backup concrete is first presented in the 1965 Symposium. This means that no information about this topic (the compressive strength of the backup concrete) was presented in any earlier publications. Second, if a recommendation is presented in a certain time period, it is assumed that that information is relevant for the subsequent time periods, unless a new recommendation about the same topic is presented. For example, in “Design Objectives,” the standard for deflection to be less than $h/240$, which was presented initially in the 1965 Symposium, is assumed to remain a standard for the subsequent periods of 1965-1969 and 1970-1975 because no new standard was presented in the industry literature. Lastly, recommendations about how to prevent discoloration or damage to the panel appearance are not included in these tables unless the recommendation or guidance could also contribute to the physical deterioration of the panel.

Table 1. Design Objectives				
	Pre-1965	1965 Symposium	1965-1969	1970-1975
General	<p>Trend towards larger panel sizes</p> <p>Facing concrete should have a high compressive strength to increase durability</p> <p>Vertical position thought to limit likelihood of saturation</p>	<p>Design should consider shrinkage, temperature differential, creep, handling, and erection loads, and eccentric loads when necessary</p> <p>Aim to have good consolidation, high strength, low absorption, and durability to avoid freeze-thaw</p>	<p>Handling stresses will control design</p> <p>Goal of design should be to produce crack free panels</p>	<p>Lloads to consider in panel design include all dead and live loads (including wind), earthquake forces when relevant, story drifts, stresses (caused by shrinkage, temperature differential, creep, handling, and erection), and eccentricities (from support, connection, line of load application, variations in flatness, unsymmetrical cross section, total deflection, etc.)</p>
Strength	<p>Facing concrete should have at least 5000 psi compressive strength at 28 days</p>	<p>Backup concrete should have at least 4000 compressive strength at 28 days</p> <p>Backup concrete and facing concrete should have similar properties to reduce differential shrinkage</p>	<p>Must provide adequate concrete to develop insert capacities for handling and connection</p>	

Table 1. Design Objectives (cont.)				
	Pre-1965	1965 Symposium	1965-1969	1970-1975
Shape/Dimensions	Larger panel size increases potential for bowing	<p>Height/thickness ratio should be ≤ 50</p> <p>Clear distance between lateral supports should be ≤ 32 times the effective panel thickness</p>	<p>All edges should have a 1/8 in. minimum radius to prevent chipping</p> <p>Shape of panel should accommodate handling, storage, shipping, and erection</p> <p>Unsymmetrical panel sections can increase potential for bowing</p>	
Stiffness		Deflection should be $< \text{height}/240$ and no greater than 3/4 in.		
Movement				Design of panels and adjacent materials should allow for panel movement

Table 2. Material Selection			
	Pre-1965	1965 Symposium	1965-1969
General	<p>Variety of concrete mixes are utilized to achieve different architectural expressions</p> <p>High strength concrete should be used to enable earlier stripping and handling</p> <p>Highly porous facing concrete can reduce durability and increase potential for bowing</p>	<p>To minimize cost, make facing concrete layer as thin as possible without revealing backup concrete</p>	<p>1970-1975</p> <p>Differential shrinkage can be limited by having facing concrete and backup concrete with similar properties</p> <p>Material should be thoroughly mixed</p>
Cement		<p>Cement of the same type and source should be used throughout a given project</p> <p>6 bags/cu yd of cement should be used to obtain maximum density and minimum permeability</p>	

Table 2. Material Selection (cont.)			
	Pre-1965	1965 Symposium	1965-1969
Aggregate		<p>Facing aggregate all from the same source should be used for a given project</p> <p>Facing aggregates with size greater than 3/4 in. should not be used</p> <p>Soft, non-durable aggregates and those without service records should not be used</p>	<p>Glass aggregate can react with cement, have low compressive strength, and have low bond strength with cement paste</p> <p>Natural sand and gravel aggregates have less shrinkage and produce more workable concrete</p> <p>Crushed aggregates have better bond with cement paste and aggregate lock</p> <p>Some limestones and marbles may not be durable enough for exposed aggregate work</p>
Admixtures	<p>Unspecified amounts of air entrainment are used to increase durability</p>	<p>Retarding admixtures should not be used</p> <p>Pigment content in excess of 5% is ineffective in intensifying color of mix</p> <p>Should consider cement and water reactions with retarders and potential negative effects</p>	<p>Use of accelerating admixtures to achieve high early strength is not preferred</p> <p>Mineral admixtures and pozzolans can be used to achieve smooth concrete surface</p> <p>Pigment content should be limited to < 10% and tested to ensure no reaction with other materials</p>

Table 3. Reinforcement Design and Materials				
	Pre-1965	1965 Symposium	1965-1969	1970-1975
General		<p>“Minimum Requirements for Thin-Section Precast Concrete Construction” (ACI 525-63) should be used to guide reinforcement design</p>	<p>Reinforcement should accommodate stresses induced by stripping, handling, storage, shipping, erection, and dead/live loads</p>	<p>Corrosion of reinforcement may be caused by inadequate quality of concrete, inadequate cover, and/or excessive use of calcium chloride</p>
Design		<p>Cover should be $\geq 3/8$ in.</p> <p>2x2 wire mesh should be used in panels 3 in or less in thickness</p>	<p>Cover should be ≥ 1 in. (PCI) or $1/2$ in. (ACI)</p> <p>Reinforcement should be placed as symmetrically about the panel's cross-sectional centroid as possible to prevent bowing</p>	<p>Multiple layers of reinforcement should be used, although for panels less than 6 in. thick, one layer is adequate</p> <p>Additional reinforcement should be placed along panel edges and around (window) openings</p> <p>Reinforcement spacing should be no more than twice the thickness of the panel</p> <p>Minimum cover for panels exposed to weather should be at least the nominal diameter of the reinforcement bars used, but not less than $3/4$ in.</p>
Material		<p>Galvanized mesh should be used with minimum cover, otherwise galvanized reinforcement is not necessary</p>	<p>Galvanized mesh should be used with cover less than $3/4$ in</p>	

Table 4. Form Design and Materials				
	Pre-1965	1965 Symposium	1965-1969	1970-1975
General		<p>Good formwork is essential to the quality of the panel</p>	<p>Choice of form material must balance cost, maintenance, re-use, and detail needs</p>	<p>Form should be sufficiently rigid to produce recommended casting tolerances</p> <p>Form should be sufficiently tight to prevent leakage of cement paste</p>
Design		<p>Draft allowances for pouring and curing should be included in form design</p> <p>Method of consolidation should be considered in form design</p>	<p>Recommended dimensional tolerance for form design is $\pm 1/8$ in.</p>	

Table 4. Form Design and Materials (cont.)

	Pre-1965	1965 Symposium	1965-1969	1970-1975
Materials	<p>Chemical retarders can be applied to the surface of formwork to reveal facing aggregates</p>		<p>Wood forms show wear and tear of form re-use</p> <p>Steel molds are difficult to modify and obtain dimensional control</p> <p>Fiber-glass-reinforced plastic forms provide the best overall performance</p>	<p>Concrete forms should be treated with epoxy or other plastic resins to improve stripping process</p> <p>Wood forms should be treated to prevent excessive absorption and improve form stability</p> <p>Wood forms can swell and bulge due to multiple uses</p> <p>Welded joints in steel molds and improper stacking can damage the form</p> <p>Fiber-reinforced plastic forms should be well supported along edges and flat areas to prevent bending</p>
Liners		<p>Wood liners should be sealed prior to use</p>		

Table 5. Casting and Consolidation				
	Pre-1965	1965 Symposium	1965-1969	1970-1975
General		<p>The most popular method of casting is in the horizontal position with the facing concrete poured first</p>		<p>Segregation during casting and consolidation should be avoided</p>
Casting		<p>Facing concrete should be workable (slump of 4-6 in), while the backup concrete should be drier to absorb excess moisture</p> <p>Water reducing admixtures can be used to reduce water content</p> <p>Decorative aggregate can be placed into the form first and then the cement matrix is consolidated in the form</p>	<p>Decorative facing aggregate can be rolled, pressed, or troweled into preplaced concrete</p>	
Consolidation		<p>Consolidation should be complete to ensure quality</p>		<p>Excess water in the facing and/or backup concrete should be removed prior to initial set by a vacuum process, hygroscopic materials, or low-slump backup concrete</p>

Table 6. Curing, Stripping, and Storage				
	Pre-1965	1965 Symposium	1965-1969	1970-1975
Curing	Curing methods include steam curing, removal of excess water by vacuum from the wet concrete, or application of curing compounds	The curing position in the yard is the greatest factor in increased potential for bowing	Shrinkage during curing should be avoided	<p>Curing should be controlled to minimize excessive evaporation, which causes tensile stresses and cracking on panel surface</p> <p>Initial curing in the form is the most important phase due to use of high early strength concrete</p> <p>Curing after stripping is difficult to control and achieve due to accommodating finishing techniques</p>
Stripping		<p>High strength concrete should be used to enable early stripping</p> <p>Stripping usually occurs 18 hours after casting or when sufficient strength has been gained</p>	<p>Cracking can occur due to thermal shock or minor mishandling during stripping</p> <p>To overcome form suction, air jets can be used during the stripping operation</p>	
Storage	Panels are stacked in storage areas during curing	Panels are set up against a framing system for storage	<p>Panels should be supported at two points only, with proper blocking in a given plane, to avoid bowing and cracking</p> <p>Shipping should be considered in determining how panels are stored to minimize handling</p>	<p>Panels should be protected to avoid excessive evaporation/temperatures below 50°F</p> <p>On-site storage should protect against excessive evaporation, temperatures below 50°F, and soiling</p>

Table 7. Surface Finishes and Treatments				
	Pre-1965	1965 Symposium	1965-1969	1970-1975
General		Exposed aggregate finish has been the most popular surface finish		
Exposed Aggregate Finish		<p>Acid washing with 5-10 percent muriatic acid occurs 3-7 days after casting</p> <p>Application of acid (wash or etching) can react with gray portland cement and result in white silicate deposits on the surface if the concrete is not well cured</p> <p>Gap-graded aggregate in the facing concrete achieve a more desirable finish</p>	Facing aggregate may be graded to a more restrictive size limitation to improve uniformity and contact between coarse aggregate and cement matrix and to reduce segregation	<p>Acid etching can damage galvanized reinforcement without sufficient cover</p> <p>Sand or other abrasive blasting can damage reinforcement without sufficient cover</p>
Other Finishes	Cracks should be reduced by texturing the panel surface with a broom or swirl finish		Well-graded facing aggregate should be used for non-exposed aggregate finish	

Table 8. Transport, Handling, and Erection				
	Pre-1965	1965 Symposium	1965-1969	1970-1975
Transport			<p>Panels should be supported at two points during transport to avoid distortion</p>	<p>Panels should be loaded vertically and supported on an 'A' frame</p> <p>Panels should be protected against road shock to prevent distortion</p>
Handling	<p>Unevenly distributed stresses should be avoided during handling</p>	<p>Inserts used for handling should be designed for 100% impact</p> <p>Large panels are more prone to mishandling and breakages</p>	<p>Inserts are typically bolted or wire cable inserts</p> <p>Inserts have greatest capacity when loaded in pure shear, as opposed to loaded in tension</p>	<p>Handling should occur in midair with panels in a vertical position to avoid breakages</p> <p>All lifting devices or inserts should be designed with a factor safety of four</p>
Erection				

Table 9. Connection Design and Materials				
	Pre-1965	1965 Symposium	1965-1969	1970-1975
General	<p>Connections should be fire resistant, achieve correct alignment, and protected to prevent corrosion</p>		<p>A common problem is not having sufficient room to make the connection detail in the field</p>	
Design	<p>Anchor inserts should not be placed in the face of the panel to avoid marring the surface</p>	<p>Connections should be designed to resist wind loads, with equal positive and negative pressures</p> <p>Intermediate connections used to control bowing and movement can cause cracking</p>	<p>Panels should be supported at only one level (two points) to keep the panel cross-section in compression</p> <p>Hanging panels from clamp angles and clamps should be avoided and such connections should only be used to resist lateral loads</p> <p>Practical tolerance for connections is $\pm 1/2$ in.</p>	<p>Connections should be designed for eccentric loading, as well as shear, bending, tension, and bearing stresses</p> <p>Connections should be designed using a factor of safety of three</p> <p>Connection design should be evaluated against concrete failure and metal failure</p>

Table 9. Connection Design and Materials (cont.)

	Pre-1965	1965 Symposium	1965-1969	1970-1975
Materials	<p>Tests indicate that welded connections are not a problem</p> <p>Connection materials should be ductile and strong to accommodate lateral movement</p>	<p>Scorch marks caused by welding connections should be avoided</p> <p>Adequate space and tolerances should be provided for welded connections</p> <p>Corrosive resistant materials should be used where connections are exposed to corrosive action</p>	<p>Heat from welding connections may damage the panel or supporting concrete due to sudden expansion of material</p> <p>Weid should be weaker than the anchor</p> <p>Welded connections can have a reduced capacity in temperature below 0°F</p> <p>Welded connections are difficult to make corrosion resistant</p> <p>Connection material should be permanently ductile and any material coatings should not cause embrittlement</p> <p>Stainless steel, galvanized materials, or cadmium plated materials should be used to protect against corrosion, even if connection is not exposed to atmosphere</p>	

Table 10. Joint Design and Materials				
	Pre-1965	1965 Symposium	1965-1969	1970-1975
General			<p>Good workmanship is key to the success of a joint system</p> <p>All joints should be weatherproofed</p>	
Design	<p>Joints should be designed to accommodate expansion and contraction of the panel</p> <p>Joint design should prevent water from penetrating wall system</p>		<p>No joint should be less than 1/4 x 1/4 in.</p> <p>Joints should be as shallow as possible because less material is required and the material experiences less strain</p> <p>Minimum joint width should be 1/2 in.</p> <p>All joints should be aligned to help guide water movement</p>	<p>For cavity wall systems, the cavity should be vented through placement of vent tubes in all horizontal joints</p> <p>Joints should be located where maximum panel thickness occurs and in relation to understanding of weathering patterns</p>

Table 10. Joint Design and Materials (cont.)				
	Pre-1965	1965 Symposium	1965-1969	1970-1975
Materials		<p>Cement mortars should be avoided because they cannot accommodate movement.</p> <p>Mastics have a short service life</p> <p>Thermosetting plastics have longer service life</p>	<p>Compression set of joint material can cause joint failure</p> <p>Joint material should elongate but not pull off the surface of the panel (low modulus of elasticity)</p> <p>Bond breakers and backup material should be used to limit sealant depth and prevent bond from being inside the joint slot</p>	

Table 11. Cleaning, Repairs, and Coatings				
	Pre-1965	1965 Symposium	1965-1969	1970-1975
Cleaning				<p>Diluted muriatic acid can be used for cleaning stubborn stains, but may alter the panel surface</p> <p>Steam cleaning and sandblasting can be used to clean stubborn stains, but sandblasting may affect surface</p>
Repairs				<p>Repairs should be performed in good weather conditions to ensure quality of the repair</p> <p>Inserts provided for handling should be removed, filled, and repaired</p> <p>Repair work should be executed by expert craftsman to achieve good repair (structurally and aesthetically)</p>
Coatings	<p>Tests on protective coatings provide no evidence that coatings increase resistance to frost action</p>		<p>Protective coatings can cause spalling</p>	

DISCUSSION

Reviewing the numerous publications from between 1945 and 1975 reveals significant gaps in their content. For example, while ACI dedicated an entire committee to this technology, it did not recognize architectural precast wall panels as being separate from other reinforced concrete. Consequently, it must be remembered that the design, production, and assembly of architectural precast wall panels were within the larger context of reinforced concrete production and assembly, though the documents reviewed here focus on the issues specific to architectural precast wall panel. Additionally, although construction with architectural precast wall panels reduced the amount of skilled labor needed on-site, the production of this concrete technology required skilled labor in the precasting plant. The publications from this time period repeatedly state the significance of the precasters' workmanship on the quality of the panels and claim specifications and standards may not be appropriate given the need to rely on the experience of the precasters. Evidence of this hesitation is the fact that ACI did not publish a guide, let alone a standard, dedicated to architectural precast wall panels until 1992 (ACI 533R-93). Due to this deference to the precasters' judgment and experience, the publications from between 1945 and 1975 gloss over particular areas of production, such as casting methods, consolidation methods, and surface finishes and treatments.

Other interesting findings include the following: generally, not much attention was given to the thickness of the panels, which varied from 8 in. in earlier panels to 5 in. on average in mid-century architecture to as thin as 3 in. or less in particular applications.³²⁸ Given these small dimensions, thickness was only considered with respect to the height to thickness ratio as it affected the panel's potential for bending. Variations in thickness were

³²⁸ Leabu, "Problems and Performance of Precast Concrete Wall Panels," 287.

rarely recommended, presumably to keep material to a minimum. Additionally, it is significant that stainless steel was not recommended as a connection material until the 1970s, and stainless steel was never formally recommended to be used as a reinforcement material during this thirty-year period. Similarly, the recommended concrete covers were extremely shallow, even in comparison to the recommended covers at the time for beams and girders, which was 1 ½ in.³²⁹ In general, the inadequate protection against corrosion during this period exemplifies the limited understanding of its significance in the deterioration of reinforced concrete. Another interesting discovery was the more liberal deflection limits assigned to architectural precast wall panels, despite the desire to avoid cracking. For typical reinforced concrete members, the maximum allowable deflection is length (or height) divided by 360. In contrast, the maximum deflection architectural precast wall panels could experience, according to the publications from between 1945 and 1975, was length (or height) divided by 240. This more liberal deflection limit further demonstrates a narrow understanding of how significant deflection and bowing are to the condition and deterioration of architectural precast wall panels.

METHODOLOGY PART 2—IDENTIFICATION OF POTENTIAL FACTORS AND PATHS TO DETERIORATION

From these recommendations, specific factors that could influence deterioration have been identified. The potential paths to deterioration to which these factors may contribute are illustrated in the diagrams below [Table 12-17], specifically outlining paths towards cracking (in red). The factors identified from Tables 1-11 have been grouped based on how they contribute to a particular condition (in blue) and are listed below that

³²⁹ ACI Committee 318, *Building Code Requirements for Reinforced Concrete*, (Detroit, MI: American Concrete Institute, 1963), 33.

condition. For example, the factors that contribute to the condition of “shallow concrete cover” include a thin facing concrete layer, inappropriate placement of reinforcement, improper casting methods, and improper consolidation methods.

The following diagrams should be read using the arrows and the descriptors above or on the arrow to understand how the different steps towards deterioration relate. These diagrams borrow from Donella H. Meadows’ system diagrams in her 2008 book *Thinking in Systems* to convey how external factors enable or exacerbate the deterioration process. The generic system below can help to illustrate how to read them:

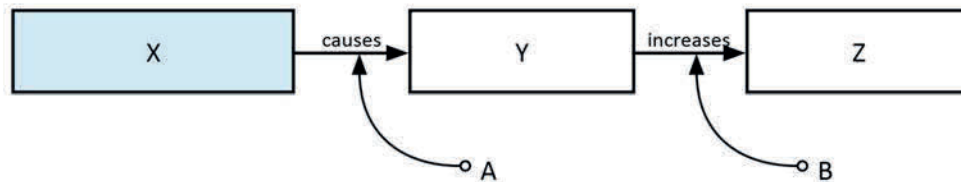

Condition *X*, enabled by the presence of *A*, causes *Y*. *Y* increases the occurrence of *Z*, which is exacerbated by the presence of *B*.

Table 12. Panel Design Conditions

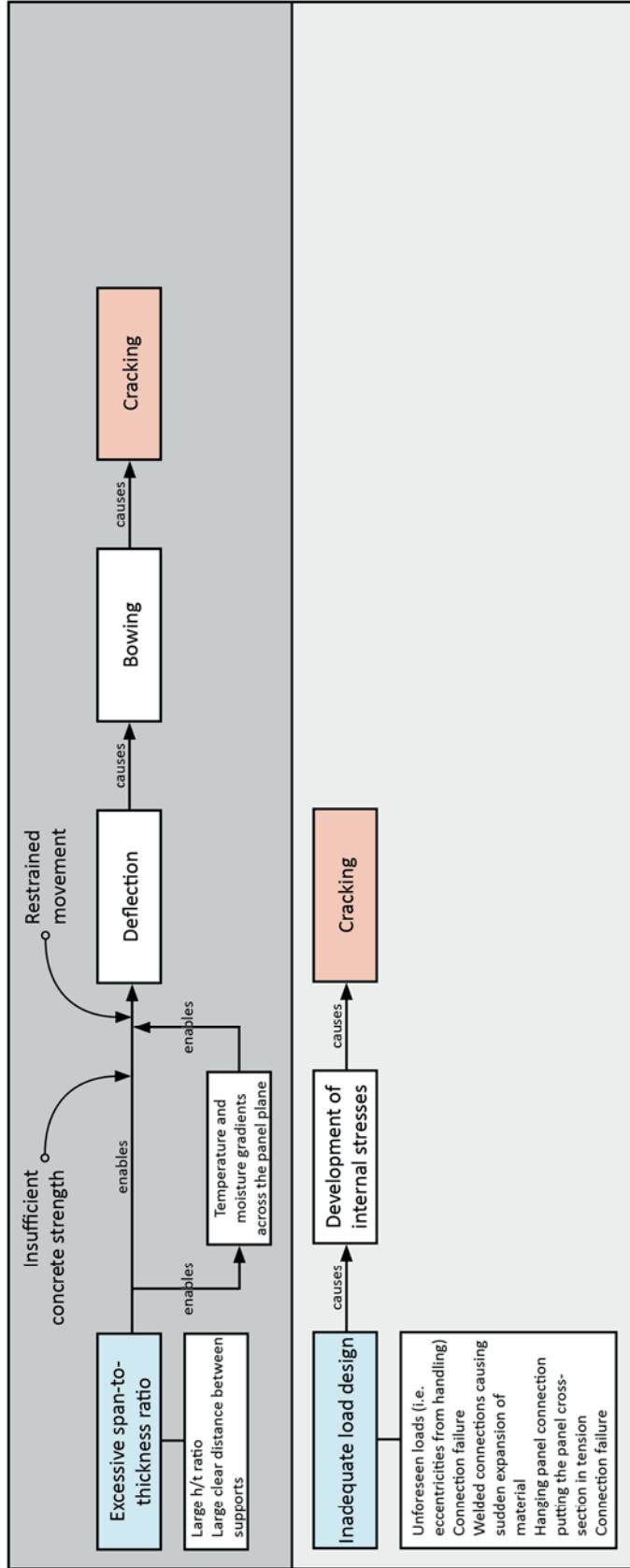

Table 13. Facing and Backup Concrete Mix Conditions

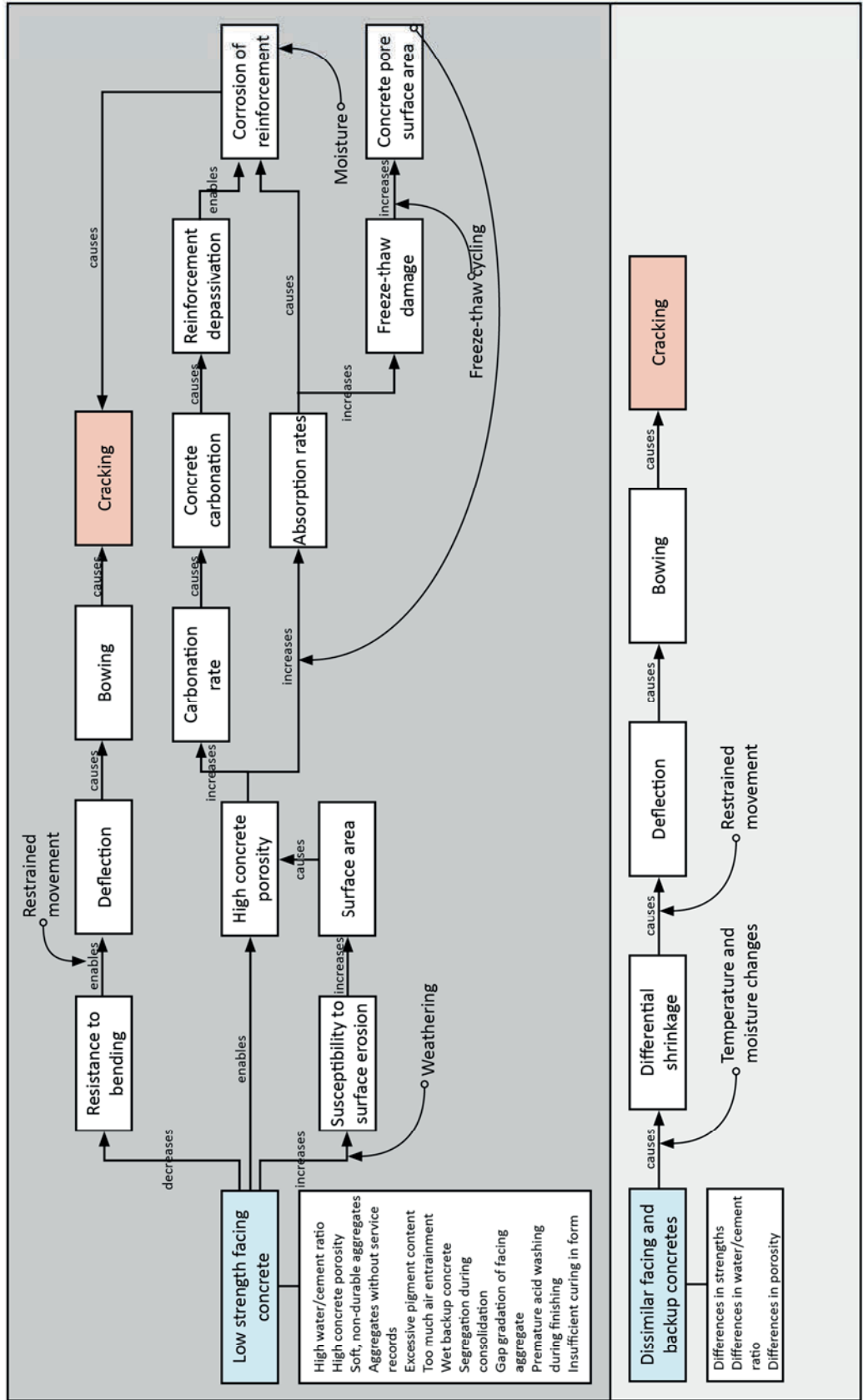

Table 13. Facing and Backup Concrete Mix Conditions (cont.)

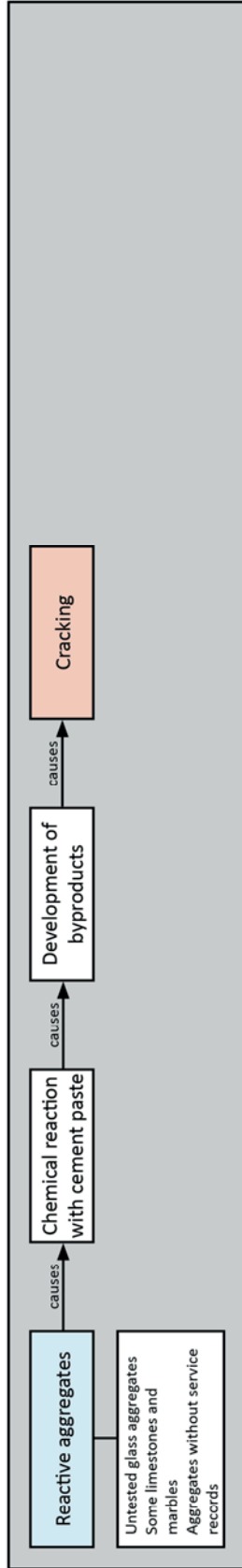

Table 14. Concrete Cover and Reinforcement Conditions

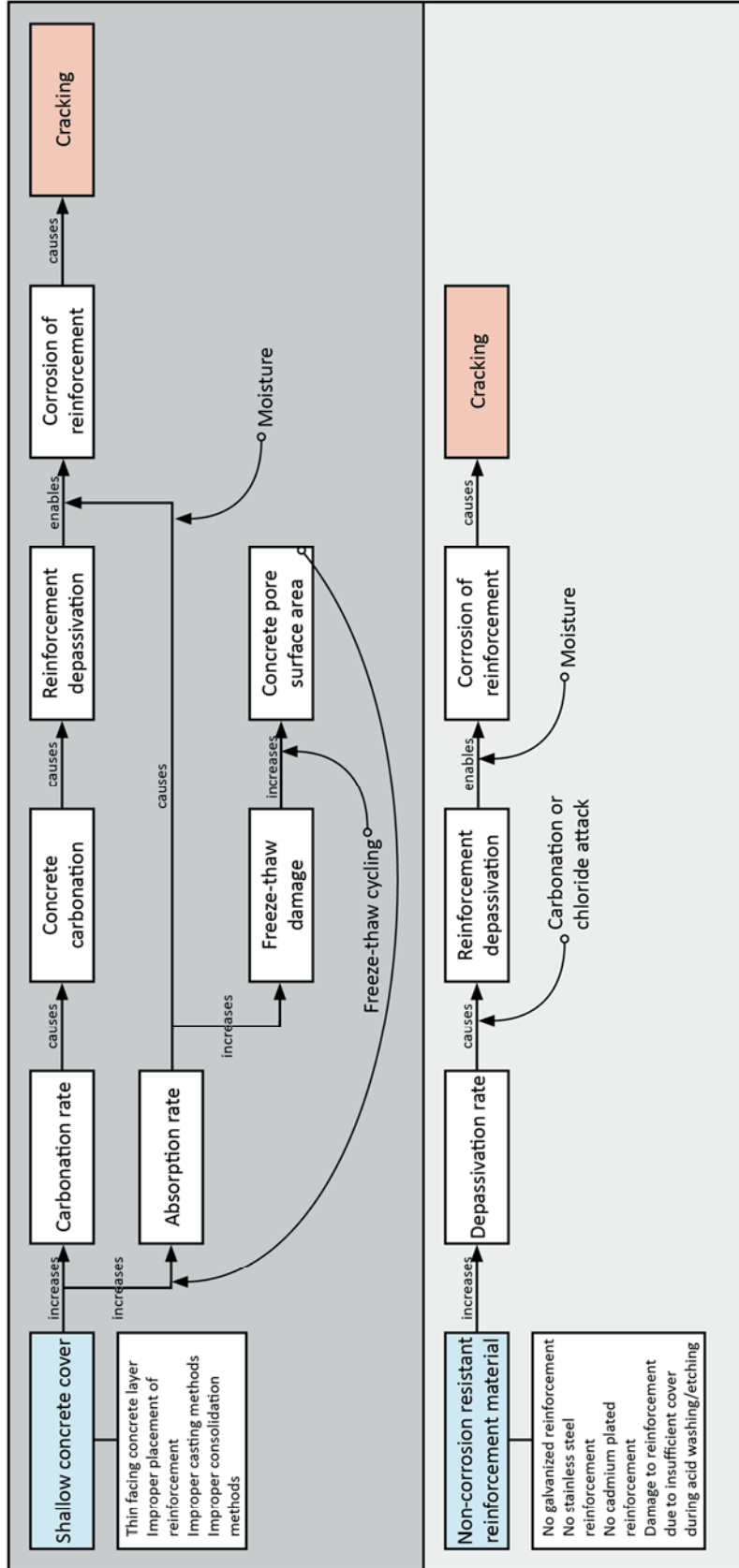

Table 14. Concrete Cover and Reinforcement Conditions (cont.)

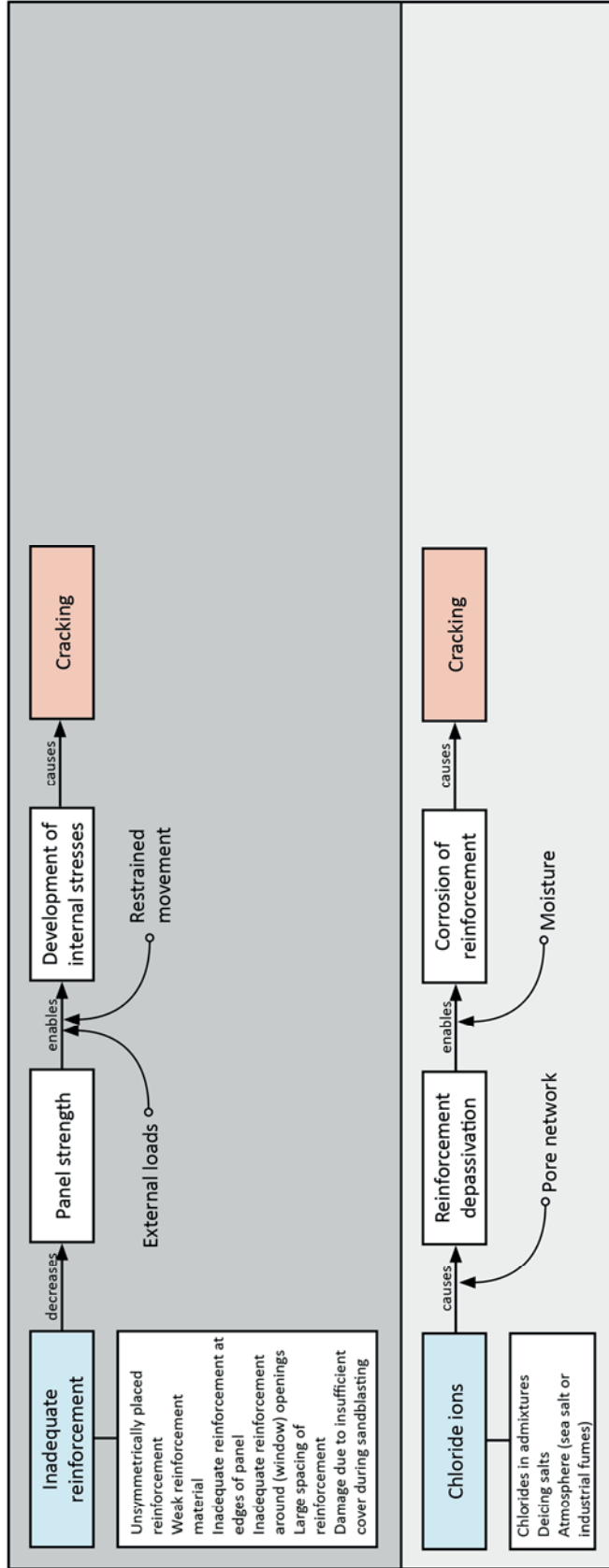

Table 15. Formwork, Casting, Curing, and Surface Treatment Conditions

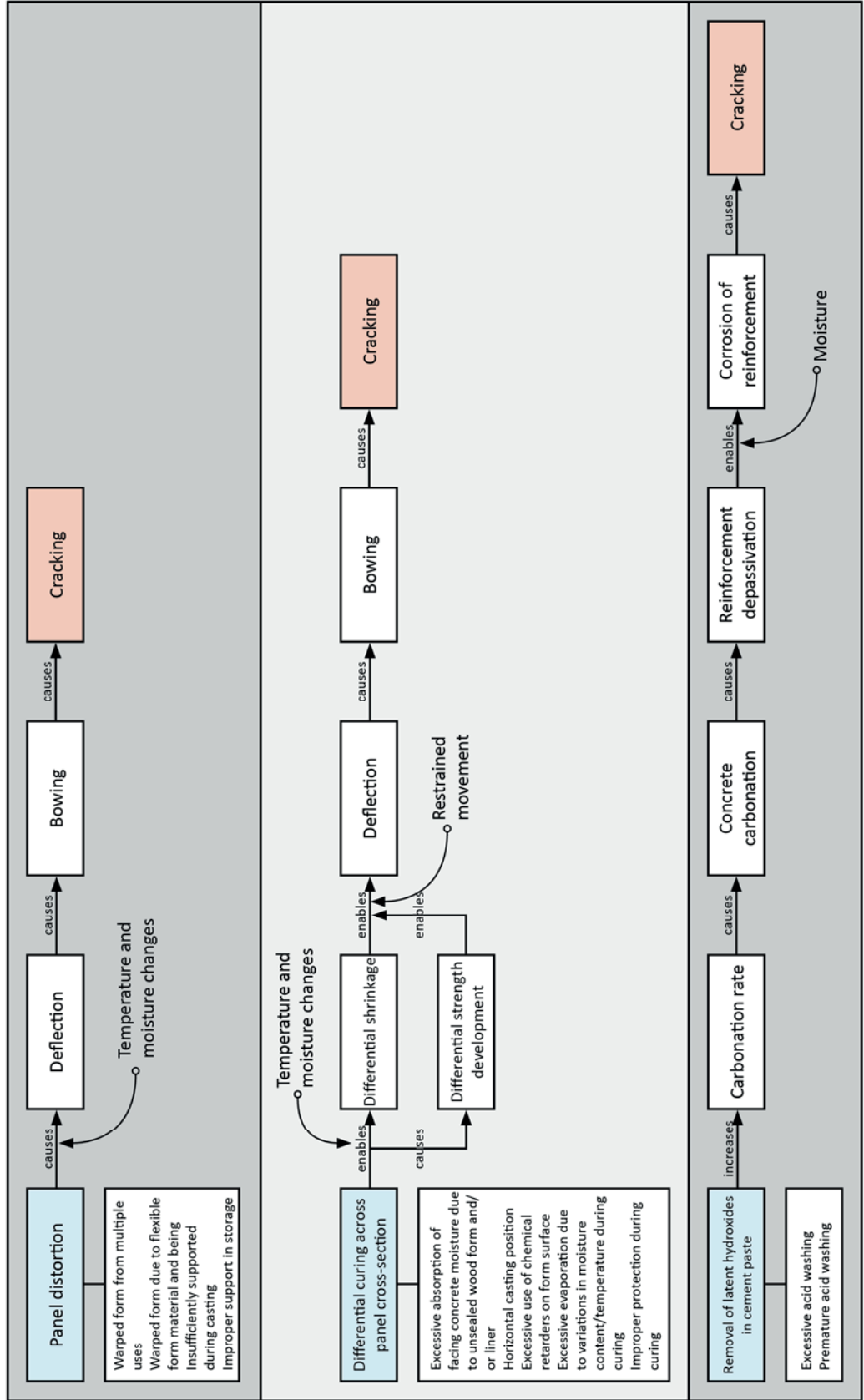

Table 16. Stripping and Handling Conditions

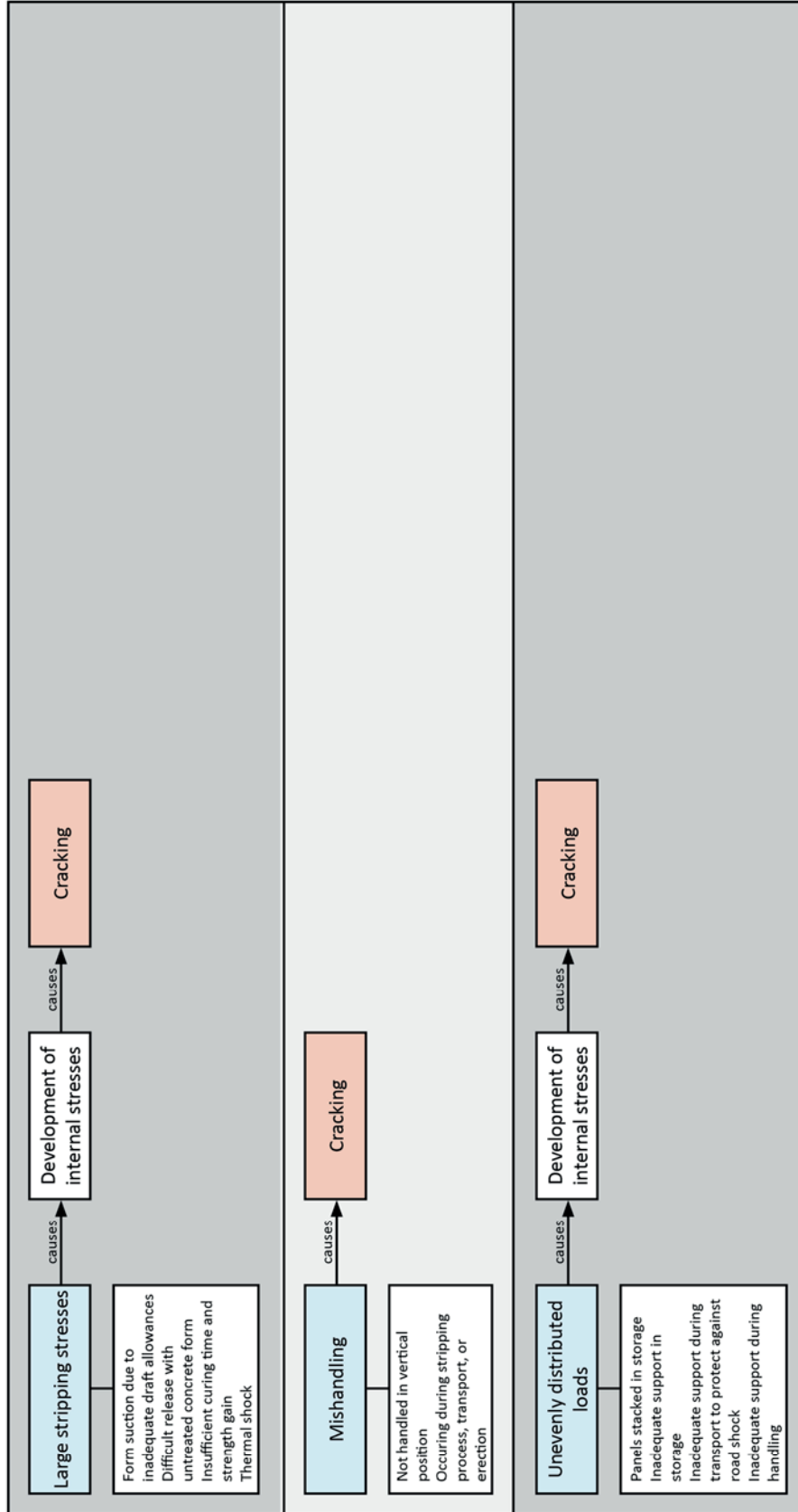

Table 16. Stripping and Handling Conditions (cont.)

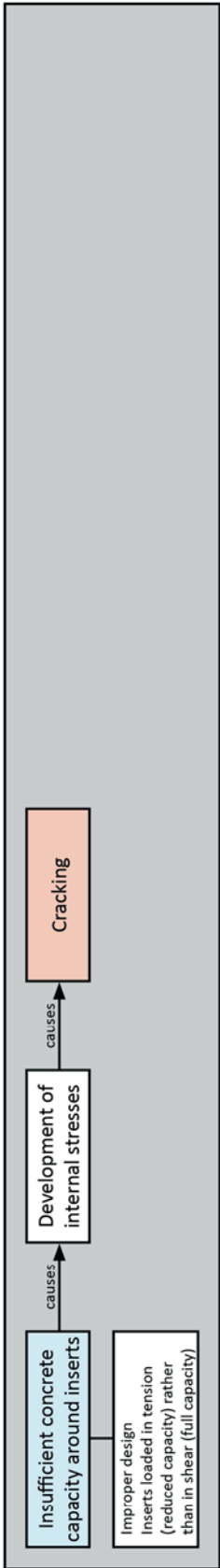
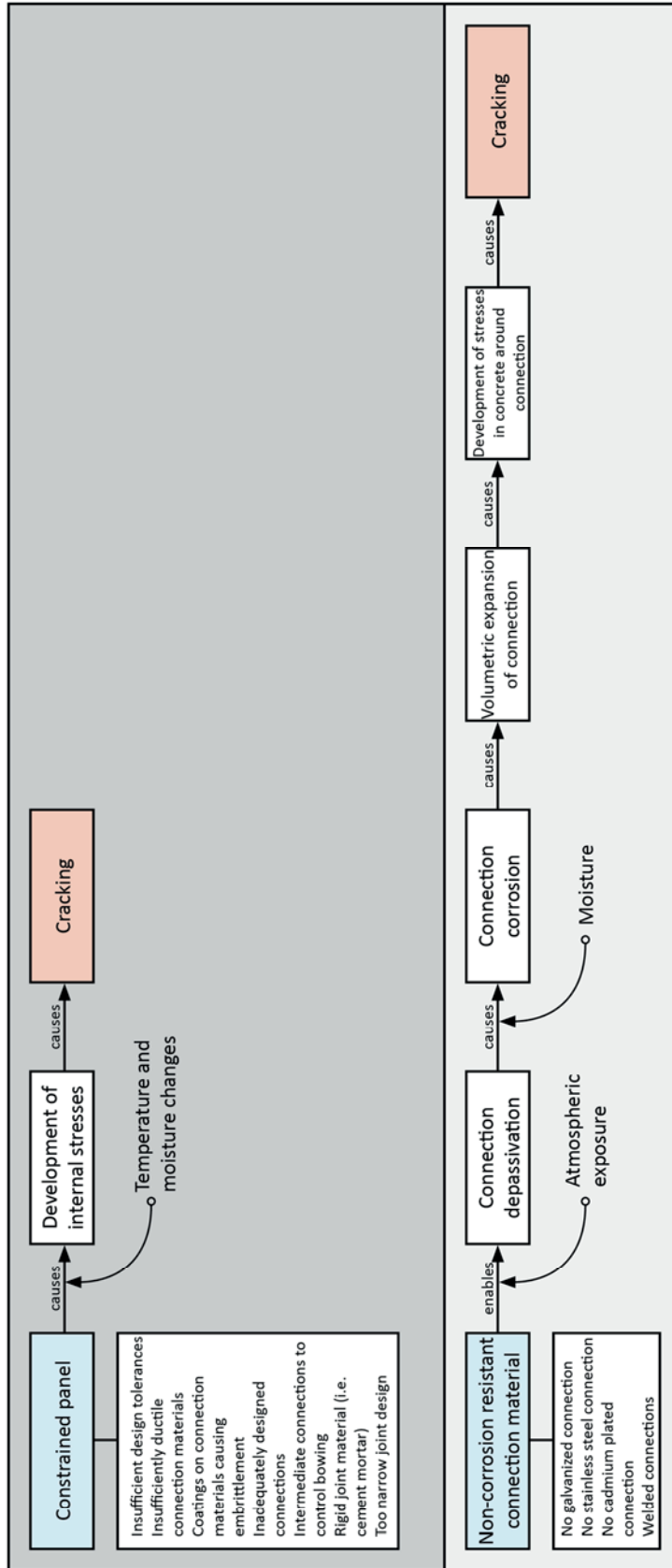

Table 17. Connection and Joint Conditions



APPLICATION OF METHODOLOGY AND FUTURE STEPS

To begin to create a preventive conservation plan for an individual building built with architectural precast wall panels using the information presented above, the date of the building's construction and the type of panels used must be identified. This information should then be compared to the recommendations and guidelines from that time period to understand the industry literature that informed the design, production, and assembly of the panels used on the building. This information must then be compared with the potential factors and paths to deterioration that have been outlined here. It is essential, however, that a conditions assessment is conducted in addition to this archival and historical research and analysis, so that pertinent external factors can be identified as well as any peculiarities to the architectural precast wall panels of the building that do not conform with the industry literature from that time period.

After creating this foundation of information, which will help to point towards areas of concern, the architectural precast wall panel system must be surveyed and monitored to learn how its condition changes with time of day and season. Monitoring and surveying can be performed with the tools presented in Chapter 4. Depending on these findings, conservation methods may be implemented in an effort to prevent further deterioration or to prevent deterioration from starting. For example, if surveying confirms that the facing concrete layer is only $\frac{3}{4}$ in. thick, which is also the only cover over the ungalvanized reinforcement, a realkalization treatment could be administered to protect the reinforcement from carbonation. Similarly, if surveying confirms that a gap graded facing aggregate was used, resulting in a porous facing concrete, an impregnation treatment could be utilized to protect the internal reinforcement and reduce further carbonation.

More research must be conducted, however, to improve both surveying techniques and current preservation strategies. Key to the success of these tools and treatment methods is getting ahead of deterioration. The surveying tools available provide only a limited view underneath the surface of the concrete, where the most critical information is located. Consequently, the accuracy and variety of tools must be enhanced. More studies must also be performed to determine how conservation methods such as cathodic protection and realkalization may be successfully applied to architectural precast wall panels to both address their unique composition and characteristics and to protect their architectural expression.

While the information provided in this thesis will be able to contribute to the creation of preventive conservation plans to preserve architectural precast wall panels, the reality is that replacement of panels may be necessary in certain situations.³³⁰ Because this concrete technology is mass-produced, pathologies have the potential to be pandemic across a given project—or a given time period. The technological evolution presented in Chapter 5 and the recommendation tables presented in this chapter reveal problematic recommendations during different time periods. For example, in the late 1960s, ACI recommended only a ½ in. minimum cover over reinforcement. If this recommendation were executed in combination with a batch of facing aggregates susceptible to alkali silica reaction, the facing concrete on the panels of that entire project would be particularly vulnerable to cracking and spalling. Replacement of the architectural precast wall panels would be more economical and safe, and, through careful design and understanding of the original technology, this could have the potential to preserve the original design intent more effectively, which was based on uniformity and consistency. Nonetheless, efforts should be

³³⁰ Anne E. Weber, Paul E. Gaudette, and Robert F. Ambruster, "John J. Earley's Mosaic Concrete: Meridian Hill Park and Edison Memorial Tower," *Concrete International* (October 2011): 31.

made to preserve the original fabric—the evidence of this significant concrete technology—before replacement is deemed necessary.

CONCLUSION

There are numerous technical challenges to the physical preservation of architectural precast wall panels. The information provided in this section about how they could potentially deteriorate, in combination with conditions assessments and monitoring of individual buildings constructed with them, can be used to create thorough and successful preventive conservation plans.

CHAPTER 7: CONCLUSION

Architectural precast concrete wall panels played a significant role in the acceptance of concrete as an architectural material and its subsequent emergence as a defining material of mid-twentieth century architecture in the United States. This concrete technology assumed this role because of the efficiency and quality achieved through the precasting process, the variety of surface finishes and architectural expressions that could be achieved relative to cast-in-place concrete, and the competitiveness of architectural precast wall panels with metal and glass curtain wall systems. In particular, because of the expressive concrete mix and/or finish of architectural precast wall panels, this concrete technology has become a character-defining feature for buildings constructed with it, as evidenced by such structures as the Denver Hilton Hotel, the Northeast Regional Library in Philadelphia, and the Buffalo Evening News Building. Consequently, the preservation of architectural precast wall panels and the buildings constructed with them is essential to the preservation of mid-century architecture and our understanding of this period of architecture.

Appreciation for their historical and architectural significance, however, is currently lacking, and this must be rectified to ensure a preservation interest in this important architectural element. To elucidate the historical significance of architectural precast wall panels, their history is explored within the context of reinforced concrete and its architectural use in America. This exploration involves examining the development of cast stone and concrete block, two important precast predecessors; revealing the significance of World War II to the architectural use of reinforced concrete; and demonstrating the importance of curtain wall construction to the success of architectural precast wall panels. Similarly, to illustrate their role as character-defining features in mid-twentieth century architecture, examples of their application are presented. These applications reveal

modernist architects' interest in architectural precast wall panels and their adaptability to a wide range of building types and designs. Moreover, the buildings and the images presented display the variety of architectural expressions that could be achieved with architectural precast wall panels.

Although acknowledging and understanding the historical and architectural significance of architectural precast wall panels will bolster an interest in preserving them, there are numerous challenges to their physical preservation that must be met. As with all historic concrete structures, the physical preservation of architectural precast wall panels is extremely complex. Significantly, current preservation strategies inadequately address the importance of preserving the original facing concrete mix and the surface finish and/or treatment applied to architectural precast wall panels. Preserving this architectural expression, however, is essential to preserving this concrete technology and the buildings constructed with it. Thus, to preserve as much historic fabric as possible, we must adopt a preventive conservation approach rather than rely on reactive conservation strategies, which jeopardize the integrity of architectural precast wall panels. Towards this end, the potential factors that may contribute to their deterioration have been identified by examining publications providing technical information, guidance, and recommendations about the design, production, and assembly of this concrete technology from between 1945 and 1975. Reviewing these publications reveals the concrete industry's struggle not to restrict the artistic results achieved through the experience and judgment of the individual precasters while still standardizing this concrete technology's production and assembly to ensure the quality of the panels produced and, subsequently, their competitiveness in the building industry. Still, reviewing this industry literature enables us to identify potential factors and the mechanisms of deterioration they lead to, which provides us with invaluable information to be used in the creation of preventive conservation plans for buildings

constructed with architectural precast wall panels. These efforts must be met, however, with increased research in surveying and preservation techniques to provide the tools to effectively implement preventive conservation plans.

Ultimately, tracing the historical and architectural significance of architectural precast concrete wall panels will help to demonstrate their value and increase interest in their preservation. But this alone is not enough: successfully preserving this significant architectural feature requires that we understand how this concrete technology has changed over time, so that we may predict and prevent its deterioration in the future.

BIBLIOGRAPHY

MID-CENTURY MODERN, CONCRETE, AND ITS PRESERVATION

Fixler, David N. "Is It Real and Does It Matter? Rethinking Authenticity and Preservation." *Journal of the Society of Architectural Historians* 67/1 (March 2008): 11-13.

Gelernter, Mark. *A History of American Architecture: Buildings in Their Cultural and Technological Context*. (Hanover: University Press of New England, 1999).

Goldberger, Paul. "Modernist Preservation: A Battle Far from Won." Lecture Given to Cincinnati Preservation Association. 25 April 2013.
<http://www.paulgoldberger.com/lectures/modernist-preservation-a-battle-far-from-won/>.

Longstreth, Richard. "I Can't See It; I Don't Understand It; And It Doesn't Look Old to Me." *Forum Journal* 27/1 (Fall 2012): 35-45.

Morehead, Vanessa Jean. *Conserving America's Recent Past Heritage: The Mid-Century Modern Rehabilitation Process*. Masters thesis. University of North Carolina at Greensboro (2010).

Mitchell, Stephen M. *Modernism on Trial: An Analysis of Historic Preservation Debates in Chicago*. Masters thesis. Illinois State University (2014).

Prudon, Theodore H.M. *Preservation of Modern Architecture*. (Hoboken, NJ: John Wiley & Sons, Inc., 2008).

Roth, Leland M. *American Architecture: A History*. (Boulder, CO: Westview Press, 2001).

HISTORY OF REINFORCED CONCRETE

Addis, Bill. "Concrete and Steel in Twentieth Century Construction: From Experimentation to Mainstream Usage." In *Structure and Style: Conserving Twentieth Century Buildings*. Edited by Michael Stratton. (London: E & FN Spon, 1997).

Addis, Bill, and Michael Bussell. "Key Development in the History of Concrete Construction." In *Concrete Building Pathology*. Edited by Susan McDonald. (Oxford: Blackwell Science Ltd, 2003).

Allen, Edward, and Joseph Iano. *Fundamentals of Building Construction: Materials and Methods*. (Hoboken, NJ: John Wiley & Sons, Inc., 2009).

Collins, Peter. *Concrete: The Vision of a New Architecture*. (McGill-Queens University Press, 2004, originally published 1959).

Cowden, Adrienne B., and David P. Wessel. "Cast Stone." In *Twentieth Century Building Materials: History and Conservation*. (Los Angeles, CA: Getty Conservation Institute, 2014).

Forty, Adrian. *Concrete and Culture: A Material History*. (London: Reaktion Books, Ltd., 2013).

Friedman, Donald. *Historical Building Construction: Design, Materials, and Technology*. 2nd Ed. (New York, NY: W.W. Norton & Company, Inc., 2010).

Simpson, Pamela H., Harry J. Hunderman, and Deborah Slaton. "Concrete Block." In *Twentieth Century Building Materials: History and Conservation*. (Los Angeles, CA: Getty Conservation Institute, 2014).

Slaton, Amy E., Paul E. Gaudette, William G. Hime, and James D. Connolly. "Reinforced Concrete." In *Twentieth Century Building Materials: History and Conservation*. (Los Angeles, CA: Getty Conservation Institute, 2014).

Watts, Andrew. *Modern Construction Handbook*. (New York: SpringerWien, 2010).

HISTORY AND DEVELOPMENT OF ARCHITECTURAL PRECAST CONCRETE WALL PANELS

Cellini, Jenna. "The Development of Precast Exposed Aggregate Concrete Cladding: The Legacy of John J. Earley and the Implications for Preservation Philosophy." Masters thesis. University of Pennsylvania (2008).

Earley, John J. "Architectural Concrete Makes Prefabricated Houses Possible." *Journal of the American Concrete Institute* (May-June 1935): 513-526.

Hunt, T.W. "Precast Concrete Wall Panels: Historical Review." *Symposium on Precast Concrete Wall Panels* (ACI Publication, 1965): 3-15.

Hunt, William Dudley. *The Contemporary Curtain Wall*. (New York: F.W. Dodge Corp, 1958).

"Moderate-Cost House Construction and Equipment." *Architectural Record* 78/2 (August 1935): 101-144.

Morris, A.E.J. *Precast Concrete in Architecture*. (London: George Goodwin, 1978).

Peterson, J. L. "History and Development of Precast Concrete in the United States." *Proceedings—American Concrete Institute* 50/2 (1954): 477-96.

True, Graham. *Decorative and Innovative Use of Concrete*. (Whittles Publishing, 2012).

Watts, Andrew. *Modern Construction Envelopes*. (Berlin: Ambra, 2014).

APPLICATION OF ARCHITECTURAL PRECAST CONCRETE WALL PANELS IN MID-CENTURY ARCHITECTURE

Brust, Amelia. "Board Approval Signals New Chapter for Library." *The Temple News* (19 March 2012). <http://temple-news.com/news/board-approval-signals-new-chapter-for-library/>.

Cossutta, Aldo. "From Precast Concrete to Integral Architecture." *Progressive Architecture* (October 1966): 196-207.

"From Art Gallery to Art Museum." The Walters Art Museum. Last accessed 9 February 2016. <http://thewalters.org/about/history/gallery.aspx>.

Gray, Christopher. "Streetscapes / The MetLife Building, Originally the Pan Am Building; Critics Once Called It Ugly; Now They're Not Sure." *The New York Times* (7 October 2001). <http://www.nytimes.com/2001/10/07/realestate/streetscapes-metlife-building-originally-pan-am-building-critics-once-called-it.html?pagewanted=all>.

"Precast Panels on a Frame." *Progressive Architecture* (September 1964): 156-161.

"The Buffalo Evening News Building." DOCOMOMO-US. Last modified 3 May 2014. http://www.docomomo-us.org/register/fiche/buffalo_evening_news_building.

"Three Precast Buildings from the Office of Marcel Breuer and Associates." *Architectural Record* (March 1973): 117-125.

REINFORCED CONCRETE: PATHOLOGIES AND PRESERVATION

ACI Committee 222. *Guide to Design and Construction Practices to Mitigate Corrosion in Reinforcement in Concrete Structures*. (Detroit, MI: American Concrete Institute, 2011).

ACI Committee 546. *Guide to Concrete Repair*. (Detroit, MI: American Concrete Institute, 2014).

Bertolini, Luca, Maddalena Carsana, and Elena Redaelli "Conservation of Historical Reinforced Concrete Structures Damaged by Carbonation Induced Corrosion by Means of Electrochemical Realkalisation." *Journal of Cultural Heritage* 9/4 (2008): 376-385.

Bouchaala, F., et. al. "Carbonation Assessment in Concrete by Nonlinear Ultrasound." *Cement and Concrete Research* 41 (2011): 557-559.

Bouchaala, Fateh, et. al. "Effect of Carbonation on the Nonlinear Response of Concrete." *Acoustical Society of America* 10 (2010).

Broomfield, John P. *Corrosion of Steel in Concrete: Understanding, Investigation, and Repair*. (New York, NY: Taylor & Francis, 2007).

- Daniels, David J. *Ground Penetrating Radar*. 2nd Edition. (London: The Institution of Electrical Engineers, 2004).
- Darimont, A. "Concrete – Pathology – Secondary Precipitations." *Microscopy Research and Techniques* 25 (1993): 179-180.
- Emmons, P.H., and A.M. Vaysburd. "System Concept in Design and Construction of Durable Concrete Repairs." *Construction and Building Materials* 10/1 (1996): 69-75.
- Fontana, Mars G. *Corrosion Engineering*. 3rd Edition. (New York: McGraw-Hill Book Company, 1985).
- Franzoni, Elisa, et. al. "Improvement of Historic Reinforced Concrete/Mortars by Impregnation and Electrochemical Methods." *Cement & Concrete Composites* 49 (2014): 50-58.
- Gaudette, Paul E., and Deborah Slaton. "Preservation of Historic Concrete." *Preservation Briefs* 15 (Washington, DC: National Park Service, Heritage Preservation Services, 2007).
- Goncalves, Ana Paula A. "Corrosion Prevention in Historic Concrete—Monitoring the Richards Medical Laboratories." Masters thesis. University of Pennsylvania, 2011.
- Gjørsv, Odd E. "Durability of Concrete Structures." *Arab J Sci Eng* 36 (2011): 151-172.
- Leucci, Giovanni. "Ground Penetrating Radar: An Application to Estimate Volumetric Water Content and Reinforced Bar Diameter in Concrete Structures." *Journal of Advanced Concrete Technology* 10 (2012): 411-422.
- Linton, Linnea M. "Delamination in Concrete: A Comparison of Two Common Nondestructive Testing Methods." *APT Bulletins* 36/2-3 (2005): 21-27.
- Macdonald, Susan. *Concrete Building Pathology*. (Oxford: Blackwell Science Ltd, 2003).
- Maierhofer, C. "Nondestructive Evaluation of Concrete Infrastructure with Ground Penetrating Radar." *J. Mater. Civ. Eng.* 15/3 (2003): 287-297.
- Maslehuddin, M. "Special Issue on Concrete Durability." *Cement & Concrete Composites* 25 (2003): 399.
- Mather, Bryant. "Concrete Durability." *Cement & Concrete Composites* 26 (2004): 3-4.
- Ozol, Michael A. and Donald O. Dusenberry. "Deterioration of Precast Concrete Panels with Crushed Quartz Coarse Aggregates due to Alkali-Silica Reaction." *Journal of the American Concrete Institute—Special Publication* 131 (1992): 407-416.
- Pashina, Brian J. "Crack Repair of Precast Concrete Panels." *Concrete International* (August 1986): 22-26.

Soutsos, Marios. *Concrete Durability: A Practical Guide to the Design of Durable Concrete Structures*. (Liverpool, UK: Thomas Telford Ltd., 2010).

"Types and Causes of Concrete Deterioration." Portland Cement Association. IS536

Vaysburd, Alexander M. "Holistic System Approach to Design and Implementation of Concrete Repair." *Cement & Concrete Composites* 28 (2006): 671-678.

Vaysburd, A.M., and P.H. Emmons. "How to Make Today's Repairs Durable for Tomorrow—Corrosion Protection in Concrete Repair." *Construction and Building Materials* 14 (2000): 189-197.

Wang, Zhendi, et. al. "Relative Humidity and Deterioration of Concrete Under Freeze-Thaw Load." *Construction and Building Materials* 62 (2014): 18-27.

Wei, Shiping, et. al. "Microbiologically Induced Deterioration of Concrete – A Review." *Brazilian Journal of Microbiology* 44/4 (2013): 1001-1007.

Woodson, R. Dodge. *Concrete Structures: Protection, Repair and Rehabilitation*. (Oxford: Elsevier, Inc., 2009).

ARCHITECTURAL PRECAST WALL PANELS: PATHOLOGIES AND PRESERVATION

ACI Committee 533. *Guide for Precast Concrete Wall Panels*. (Detroit, MI: American Concrete Institute, 1993).

Clark, Brent, and Aaron Clark. "Repairing Misaligned Reveals in Architectural Concrete Panels." *Concrete International* (November 2010): 51-55.

Folic, R.J. "Classification of Damage and Its Causes as Applied to Precast Concrete Buildings." *Materials and Structures* 24 (1991): 276-285.

Gorrell, Todd A. "Condensation Problems in Precast Concrete Cladding Systems in Cold Climates." *Journal of Testing and Evaluation* 39/4 (2010): 1-7.

Levitt, Maurice. *Precast Concrete: Materials, Manufacture, Properties and Usage*. (Taylor & Francis, Ltd, 2008).

Maness, George L. "Preventing Wall Deterioration." *Journal of Property Management* 56/5 (Sep/Oct 1991): 33-36.

Meason, Ned, and Dennis E. Myers. "Patching Procedures for Defects in Architectural Concrete." *Concrete International* 3/10 (1981): 44-49.

Nasvik, Joe. "Diagnosing Problems with Decorative Concrete." *Concrete Construction* (October 2003): 48-52.

Ozol, M.A., and D.O. Dusenberry. "Deterioration of Precast Concrete Panels with Crushed Quartz Coarse Aggregate Due to Alkali Silica Reaction." *ACI SP 131-22 Durability of Concrete* (March 1992): 407-415.

Redaelli, Elena, et. al. "Cathodic Protection with Localised Galvanic Anodes in Slender Carbonated Concrete Elements." *Materials and Structures* 47 (2014): 1839-1855.

Varjonon, Saija, Jussi Mattila, Jukka Lahdensivu, and Matti Pentti. "Conservation and Maintenance of Concrete Facades: Technical Possibilities and Restrictions." Research Report 136 (Tampere University of Technology: Institute of Structural Engineering, 2006).

Weber, Anne E., Paul E. Gaudette, and Robert F. Ambruster. "John J. Earley's Mosaic Concrete: Meridian Hill Park and Edison Memorial Tower." *Concrete International* (October 2011): 28-33.

PREVENTIVE CONSERVATION

Chew, M.Y.L., S.S. Tan, and K.H. Kang. "A Technical Evaluation Index for Curtain Wall and Cladding Facades." *Structural Survey* 22/4 (2004): 210-227.

Dann, Nigel, and Timothy Cantell. "Maintenance: From Philosophy to Practice." *Journal of Architectural Conservation* 11/1 (2005): 42-54.

Finke, Alice Louise. "Implementing Preventive Architectural Conservation: Do Historic Property Stewards in the United States Possess the Tools to Meet the Challenge." Masters thesis. University of Pennsylvania, 2008.

Henry, Michael. "Preventive Conservation, Sustainability, and Environmental Management." *Conservation: The GCI Newsletter* 22/1 (2007): 4-9.

Staniforth, Sarah. *Historical Perspectives on Preventive Conservation*. (Los Angeles, CA: Getty Conservation Institute, 2013).

Staniforth, Sara, Richard Kerschner, and Jonathan Ashley-Smith. "Sustainable Access: A Discussion About Implementing Preventive Conservation." *Conservation: The Getty Conservation Institute Newsletter* 19/1 (2004): 10-16.

Waller, Robert, and Stefan Michalski. "Effective Preservation: From Reaction to Prevention." *The Getty Conservation Institute Newsletter* 19/1 (Spring 2004).

RECOMMENDED PRACTICES AND OTHER TECHNICAL DOCUMENTS ABOUT ARCHITECTURAL PRECAST CONCRETE WALL PANELS

Adams, Richard C. and Victor Leabu. "Design of Precast Concrete Wall Panels." *ACI Journal* (July 1971): 504-513.

- Bouzan, Benedict. "Architectural Aspects of Architectural Precast Concrete." *PCI Journal* (April 1968): 75-77.
- Buehner, Paul. "Polished Precast Products." *PCI Journal* (April (1968): 59-61.
- Cavanaugh, Richard E. "Contractor Considerations for Architectural Precast Concrete." *PCI Journal* (April 1968): 84-87.
- Collens, Geoffrey A. "Precast Concrete Wall Panels: Architectural Commentary." *Symposium on Precast Concrete Wall Panels*. ACI Publication SP-11 (1965): 89-119.
- "Concrete Walls: Cast in Place, Precast, Masonry." Portland Cement Association (January 1972).
- Downing, John F. "A Manual for Quality Control." *PCI Journal* (April 1968): 57-59.
- Gerfen, Howard W., and John R Anderson. "Joinery of Precast Concrete." *Journal of the American Concrete Institute* (October 1962): 1435-1442.
- Gilbane, Thomas S. "Precast Concrete Panel Multistory Construction." *Journal of the American Concrete Institute* (May 1950): 725-731.
- Grafflin, A.C. "Cementstone Precast Construction." *Journal of the American Concrete Institute* (November 1948): 193-204.
- Gutmann, Phillip W. "Precast Concrete Wall Panels: Manufacturing Processes." *Symposium on Precast Concrete Wall Panels*. ACI Publication SP-11 (1965): 47-53.
- Gyimesi, Andrew. "Multi-Use Integrated Wall Panels." *PCI Journal* (April 1968): 88-90.
- Hanson, J.A. "Tests for Precast Wall Panels." *Journal of the American Concrete Institute* (April 1964): 369-382.
- Hanson, J.A., and D. P. Jenny. "Precast Concrete Panels: Materials and Tests." *Symposium on Precast Concrete Wall Panels*. ACI Publication SP-11 (1965): 19-28.
- Hunt, T.W. "Strength Tests to Meet Specifications." *PCI Journal* (April 1968): 65-68.
- Hunt, William Dudley. *The Contemporary Curtain Wall*. (New York: F.W. Dodge Corp, 1958).
- Lawson, Fay. "Panel Discussion on Production and Quality Control for Architectural Precast Concrete." *PCI Journal* (April 1968): 68-74.
- Leabu, Victor. "Precast Concrete Wall Panels: Design Trends and Standards." *Symposium on Precast Concrete Wall Panels*. ACI Publication SP-11 (1965): 31-44.
- Leabu, Victor, and R.C. Adams. "Fabrication, Handling and Erection of Precast Concrete Wall Panels." *ACI Journal* (April 1970): 310-340.

- Leabu, Victor F. "Connections for Precast Concrete Wall Panels." *ACI Paper SP 22-8* (1969)
- Leabu, Victor F. "Problems and Performance of Precast Concrete Wall Panels." *Journal of the American Concrete Institute* (October 1959): 287-298.
- Leabu, Victor F., and Daniel P. Jenny. "Selection and Use of Materials for Precast Concrete Wall Panels." *ACI Journal* (October 1969): 814-822.
- Leabu, Victor F., and J.A. Hanson. "Quality Standards and Tests for Precast Concrete Wall Panels." *ACI Journal* (April 1969): 270-275.
- Pfeifer, D.W., and J.A. Hanson. "Precast Concrete Wall Panels: Flexural Stiffness of Sandwich Panels." *Symposium on Precast Concrete Wall Panels*. ACI Publication SP-11 (1965): 67-86.
- Pletta, D. H., E.F. Massie, and H.S. Robins. "Corrosion Protection of Thin Precast Concrete Sections." *Journal of the American Concrete Institute* (March 1950): 513-525.
- "Precast Concrete: Wall Panels." Portland Cement Association (October 1954).
- Raths, C.H. "Engineering Design of Architectural Precast Concrete." *PCI Journal* (April 1968): 77-84.
- Raths, C.H. "Production and Design of Architectural Precast Concrete." *PCI Journal* (June 1967): 18-43.
- Roy, A.A. "Panel Discussion on Architectural and Engineering Design of Architectural Precast Concrete." *PCI Journal* (April 1968): 90-96.
- Schutz, R.J. "Design of Joints in Precast Concrete Wall Panels." *PCI Journal* (October 1966): 60-67.
- Schutz, Raymond J. "Architectural Precast Concrete Joint Details." *PCI Journal* (March-April 1973): 10-37.
- Sheng, Sheng Pao. "Precast Concrete Wall Panels: Bowing, Warpage, and Movement." *Symposium on Precast Concrete Wall Panels*. ACI Publication SP-11 (1965): 57-63.
- Stevens, John. "Exposed Aggregate Products." *PCI Journal* (April 1968): 61-62.
- Thomas, J.C. "Standard Units for Architectural Walls." *PCI Journal* (April 1968): 62-65.
- Varkay, Ivan. "Manufacturer's Responsibility for Connections." *PCI Journal* (April 1968): 87-88.
- Veltman, C.J., and R.W. Johnson. "Effective Shop Drawing Communications for Precast Concrete." *PCI Journal* (February 1969): 12-31.

INDEX

- aggressive chemical exposure, 51
alkali-silica reactions, 51
Anshen and Allen, v, 41
Armestone System, v, 18
- Banker Trust Building, v, 39
Belluschi, Pietro, v, 24, 34
Blenheim building, v, 10, 11
Breuer, Marcel, v, 23, 33
Buffalo Evening News Building, v, 37, 141
- carbonation, 50, 52, 53, 58, 59, 60, 138
cast stone, 10, 12-17, 27, 67, 141
cathodic protection, 58, 60, 139
chloride ions, 50, 51, 59
concrete cover, 51, 53, 56, 78, 128
concrete masonry units, 12, 14-17, 27,
concrete shrinkage, 54, 75
Conzelman, John, 17
corrosion, 2, 49, 51, 53-56, 58, 59, 70, 74,
84, 92, 100, 127
Cossutta, Aldo, v, 32, 146
curtain wall system, 5, 21, 24, 28
- Denver Hilton Hotel, v, 31, 32, 141
DOCOMOMO, 37, 45
domestic cement industry, 8, 9, 12
- Earley, John, 20, 21, 76, 80
Edward Durell Stone and Associates, v, 37
electrochemical realkalization, 58, 60
Emory Roth and Sons, v, 39
- freeze-thaw, 51, 72, 75, 88
- Geddes, Brecher, Qualls, and Cunningham,
v, 35, 36
Gropius, Walter, v, 22, 34
- handling equipment, 28, 29, 68, 84
Hausner and Macsai, v, 40
Hennebique, Francois, 8
Holabird & Root & Burgee, v, 42, 43
Hyatt, Thaddues, 7
- impregnation treatments, 58
International Building, v, 41
- Lascelles, W.H., 17
Le Corbusier, 22
Lockstone System, v, 19
- Mathes, Herbert A. v, 42, 45
McGaw Memorial Hall, v, 42, 43
Miami Beach Public Library, v, 42, 45
Mies van der Rohe, Ludwig, v, 22, 24, 26,
27
modern architectural style, 11
MoSai, 20
Murray Lincoln Campus Center, v, 33
- Nolen & Swinburne, v, 42, 44
Northeast Regional Library, v, 35, 36, 141
- Oak Park High School, v, 42, 43
- Pan American Building, v, 30, 34
passive layer, 50, 51, 56, 60
Perret, Auguste, 10
Philadelphia Police Headquarters, v, 35
Portland cement, 7
Portland Cement Association, 9, 15, 28,
50, 66, 68
Ransome, Ernest Leslie, 8, 17
- Samuel Paley Library, v, 42, 44
Shepley, Bulfinch, Richardson, and Abbot,
v, 38
Shokbeton, 29
steel, 1, 3, 6, 8, 9, 16, 21, 24, 25, 31, 42, 48,
49, 51, 54, 56, 59, 60, 67, 74, 79, 84, 92,
93, 99, 100, 127
- Walters Art Museum addition, v, 38
Ward, William E., 7, 15
Water Tower Inn, v, 40
window-type mullion wall panel, 29
World War II, 4, 5, 11, 21, 23, 28, 65, 141
Wright, Frank Lloyd, 22