



12-1980

High-Performance Transit Planning Modes and Networks

Vukan R. Vuchic

University of Pennsylvania, vuchic@seas.upenn.edu

Follow this and additional works at: http://repository.upenn.edu/ease_papers

 Part of the [Systems Engineering Commons](#), and the [Transportation Engineering Commons](#)

Recommended Citation

Vukan R. Vuchic, "High-Performance Transit Planning Modes and Networks", *Proceedings of Mass Rapid Transit System Seminar*, 17-72. December 1980.

This paper is posted at ScholarlyCommons. http://repository.upenn.edu/ease_papers/773

For more information, please contact repository@pobox.upenn.edu.

High-Performance Transit Planning Modes and Networks

Abstract

From the introduction:

"In planning our lectures for this seminar, my colleagues and I have decided that we present here an overview of the problems of cities today, of the role of public transportation, and especially high-performance public transportation, as well as some details of planning, and characteristics of modes, their design and operations. We will thus try to combine, as much as the time allows, a general overview with technical details which many of you will be facing when you will be planning and implementing your rapid transit project in the years to come."

Disciplines

Engineering | Systems Engineering | Transportation Engineering

**PROCEEDINGS OF
MASS RAPID TRANSIT SYSTEM SEMINAR**

**Sponsored by
Ministry of Communications, R. O. C.
In Association with
Chinese Institute of Engineers, R. O. C. and
Chinese Institute of Engineers, U. S. A.**

8.53

LECTURE 1
HIGH-PERFORMANCE TRANSIT PLANNING,
MODES AND NETWORKS

BY DR. VUKAN R. VUCHIC
PROFESSOR
DEPARTMENT OF CIVIL AND URBAN ENGINEERING
UNIVERSITY OF PENNSYLVANIA

DECEMBER 9, 1980

Honorable government officials of the Republic of China, members of the Transportation Planning Board, dear colleagues, ladies and gentlemen!

I would like to express appreciation of all of us guests for your very kind invitation to us to come to your city and country. Not only are we pleased to enjoy your wonderful hospitality and learn about your country which is physically far from us, but otherwise very close to us; we are equally pleased to see your determination to improve your country through public projects and various innovations; your hard work, determination, coordinated effort by many organizations and individuals are impressive. Without them success would be difficult if not impossible; with them I am sure that you will succeed in building your rapidly growing city into a modern metropolis of Taipei.

In planning our lectures for this seminar, my colleagues and I have decided that we present here an overview of the problems of cities today, of the role of public transportation, and especially high-performance public transportation, as well as some details of planning, and characteristics of modes, their design and operations. We will thus try to combine, as much as the time allows, a general overview with technical details which many of you will be facing when you will be planning and implementing your rapid transit project in the years to come.

*

*

*

Urbanization is one of the basic characteristics of modern age. Cities on all continents are growing in population and size. Country by country is becoming what we describe as "urbanized society".

Growing cities require careful and far-sighted planning; however, in most cities planning has not been adequate at all times and they are now facing serious problems. One of the most widespread problems is inadequate transportation; we now find traffic congestion in most cities, from Lagos, Nigeria to Los Angeles, California; from Calcutta to Istanbul and from Sao Paolo to Melbourne. In many cases people have no alternative but to travel in slow, unreliable traffic on city streets.

Many cities suffer, thus, from permanent, serious congestion which paralyzes many activities: it involves economic waste, inconvenience to residents, social costs, energy waste, and causes serious environmental damage. Above all, it damages cities and makes them places which are not pleasant to live in. Since we are becoming an urbanized civilization that is a very serious global problem.

Measurements of average speeds in individual cities show that these speeds tend to decrease and eventually level off at sometimes 12, 10 or 8 km/h. That is the level of congestion which people tolerate; often they will not tolerate any more. Additional people who would like to travel either do not travel, or they go to other places. That means that activities in the city are impeded. The whole city is limited by this condition in its ability to perform various activities.

Public transportation on streets, or street transit, consisting of buses, trolleybuses and streetcars, is caught by congestion created mostly by private vehicles. In this situation neither private nor public transportation can move efficiently, but there is no stimulus for individuals to leave their cars and use transit, a change which would improve traffic flow. As long as transit service is as slow or slower than the automobile, there is no reason for drivers to change their means of travel, and we have so-called "equilibrium of intolerance". The only reasonable way to

provide medium and large cities with reliable transportation is to ensure higher performance of public transportation, that is, to provide transit systems which are physically separated from street traffic. This physical separation can be done in many different ways, but we classify separation into two basic categories:

1. Partial separation is achieved when we provide special medians, lanes, short sections of exclusive streets, tunnels, overpasses, etc. Transit vehicles still go through intersections or sections of streets with mixed traffic on the remaining sections of lines. We try to separate them as much as possible, particularly in the areas which are heavily and frequently congested. In outlying areas separation is less important. This partial separation creates the modes which we designate as semirapid transit.

2. The second type of separation is complete or full separation of transit on entire lengths of lines; that is, we provide separated right-of-way for the entire line which no vehicle other than transit can legally enter. That group of modes is designated as rapid transit.

Both types of separation - partial and full - require certain efforts and costs: we must have special land, invest in construction, and introduce more sophisticated type of control and operation than for street transit. But both types provide drastic increases in transit systems' performance in terms of speed, reliability, capacity, safety, and so on. Above all, partially or fully separated modes, which we classify as high-performance transit modes, attract passengers from other modes, as well as large numbers of new passengers, because of their much higher level of service than the slow, unreliable street transit in mixed traffic can offer.

To review the reasons for construction of high performance transit modes, the purposes of providing them are:

- to ensure high transit systems performance,
- to prevent or reduce permanent and costly congestion,
- to improve urban environment,
- to increase mobility of population;

and the last, but certainly not the least important,

- to influence growth of the city and its form; to create cities with good coordination among modes of transportation serving them and their different types of land uses.

The elements which influence the need for high performance transit include population of the city or metropolitan area, density and form of the city, degree of traffic congestion now and foreseen for the future, and the need to improve economic, social, environmental and living conditions in the city.

Let me now go in some detail, first about semirapid transit, and then rapid transit. Semirapid transit can be provided by two different technological modes: buses, i.e. highway vehicles, or by rail vehicles. When buses are partially separated from other traffic, we call them semirapid buses. When we have rail lines partially separated, we call them light rail transit. When we compare semirapid bus with light rail transit, we can see that the buses are easier to implement: they require less construction and no new type of technology. Therefore transition from any existing service to semirapid service is relatively easy. Investment costs are lower and it is easier to provide many branches and thus a better area coverage than with rail modes. Buses have the flexibility. On the other side, rail has the following advantages: it provides higher capacity than buses, higher safety, higher riding comfort; it has a stronger image for passengers as a very distinct mode with clearly designated lines; it has lower operating costs when passenger volumes

are high. Moreover, with rail transit it is possible to use electric traction which has a much better performance in terms of acceleration/ deceleration. Electricity causes virtually no noise and no exhaust. It does not depend on oil, and because of the absence of exhaust it can be used in tunnels, a very important feature in cities. Also, every guided mode allows coupling of cars, so we can have short trains for light rail transit; we can now have train units with up to 400, 500, or even 600 spaces, i.e. 5-8 times larger than buses. These larger units can provide higher speed, capacity and safety than buses at a lower operating cost. Thus when we compare these two modes, we generally see that if the right-of-way separation can be provided on a limited number of section only, buses are usually more advantageous. But, for a higher performance system transit must have rights-of-way which are mostly or fully separated from other traffic, and in that case rail modes represent the superior solution.

The following photographs illustrate traffic conditions typical for many cities. Auto traffic inflow into our medium and large cities is so massive that even freeways like the one in (1)* are very often congested. For many years the reaction was that we need more and wider highways. So we built wider highways and then even wider highways, and even that was not enough! The 18-lane freeway in (2) has not solved traffic problems; to the contrary, it created an environment which is not pleasant for the thousands of people living in the high-rise residential buildings next to it. In cities, a serious parking problem was created: if we try to accommodate all automobiles attracted by such freeways, parking becomes the dominant land use (3). Central cities, which should be the most attractive areas for people, became environments quite unfriendly to pedestrians when they are totally oriented to the automobile(4).

*Numbers in brackets () refer to the photographs.

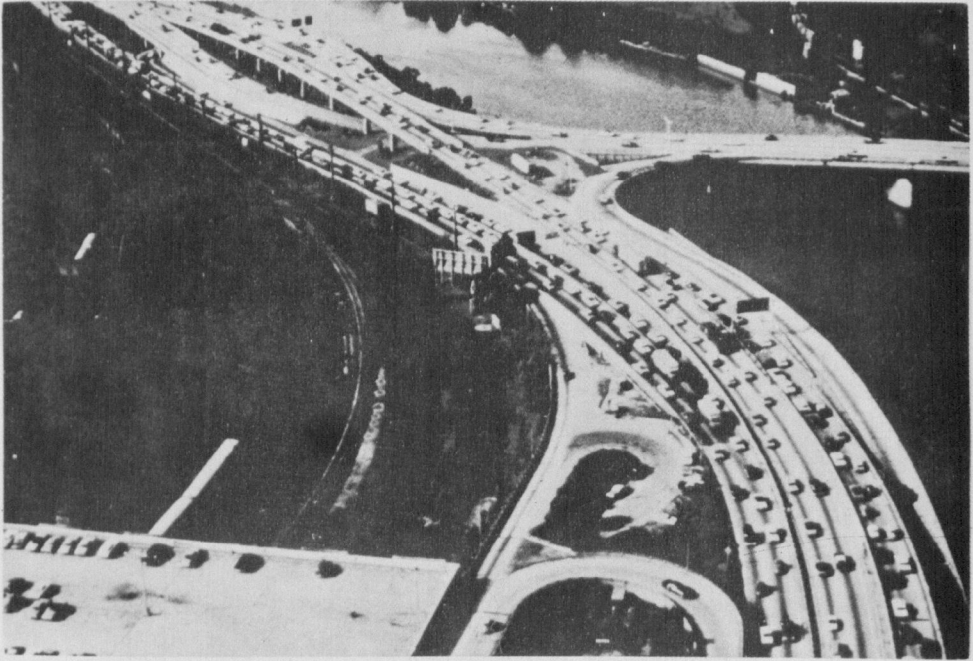

Figure 1. Freeways in central cities suffer from frequent congestion (Philadelphia)



Figure 2. Incompatible land uses: 18 highway lanes adjacent to residences (Chicago)



Figure 3. Parking as the dominant land use in the city center (Los Angeles)

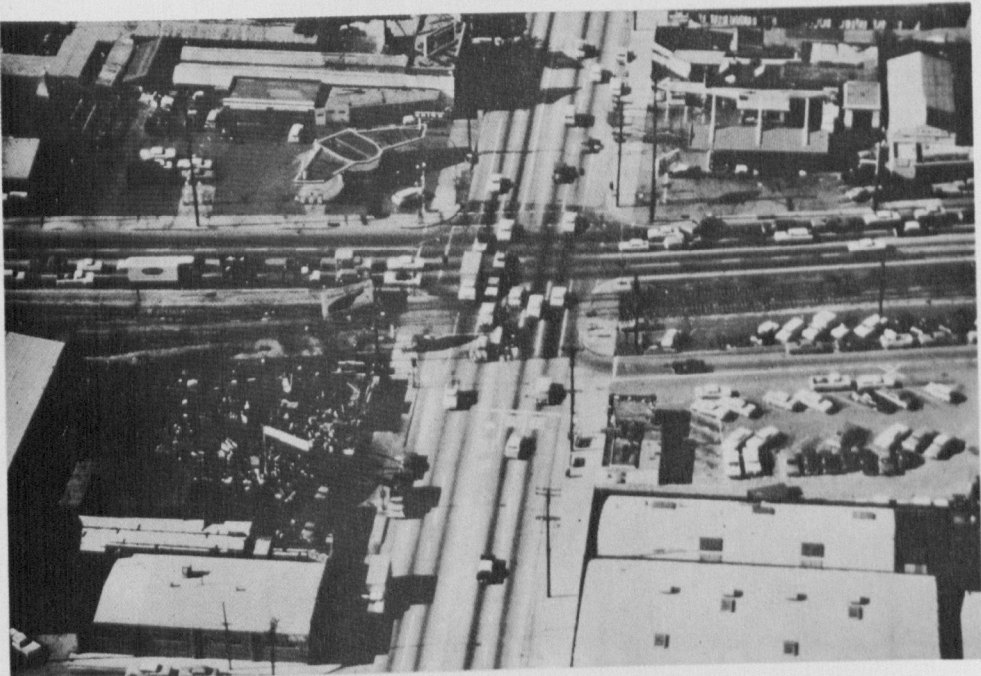

Figure 4. Auto-oriented developments do not provide a pleasant urban environment

A much better solution of urban transportation is achieved when different types of transit are utilized and favored over the private automobile. The "family of transit modes" starts with small buses which serve neighborhoods and low density areas, or as feeders to high-performance transit (5). Then we have different types of regular buses: with wide doors for fast boarding/alighting (6); with high comfort for long trips, like the bus in (7); or with high capacity, such as the articulated bus in (8). The next "step" in the family of modes is even more important: improvements of the ways or rights-of-way on which buses travel. For example, Paris introduced a number of special lanes (9) parallel with or opposite to traffic flow. Bus ridership in Paris increased greatly in recent years, mostly because buses began to go faster than automobiles on the same streets. We in the United States have a great number of freeways in cities. A few years ago, as the strong orientation toward auto decreased and the importance of improved transit became recognized, we noticed that some of those lanes can be used much more efficiently by buses than if we just try to move automobiles with very low occupancies. Such lanes represent a temporary and yet significant improvement. In some cases two lanes are used to create a single contraflow lane exclusively for buses traveling out of the city while inbound traffic is light. There are also lanes for bus travel with traffic flow (10). A special busway (11) has been built from Los Angeles to a suburban terminal from which bus lines branch out in many directions.

Coordination of buses with rail systems is very important, and Toronto has built many stations where buses enter covered driveways and people walk directly from buses into the subway through an enclosed terminal. Munich has direct transfers between bus feeders and rapid transit (12). Washington, Atlanta and Edmonton have also recently built such transfer stations.



Figure 5. Dial-a-bus for low-density suburbs



Figure 6. Bus with wide doors (W. Germany)



Figure 7. A modern US transit bus (Los Angeles)



Figure 8. A modern articulated bus (W. Germany)



Figure 9. Bus lane on a Paris street

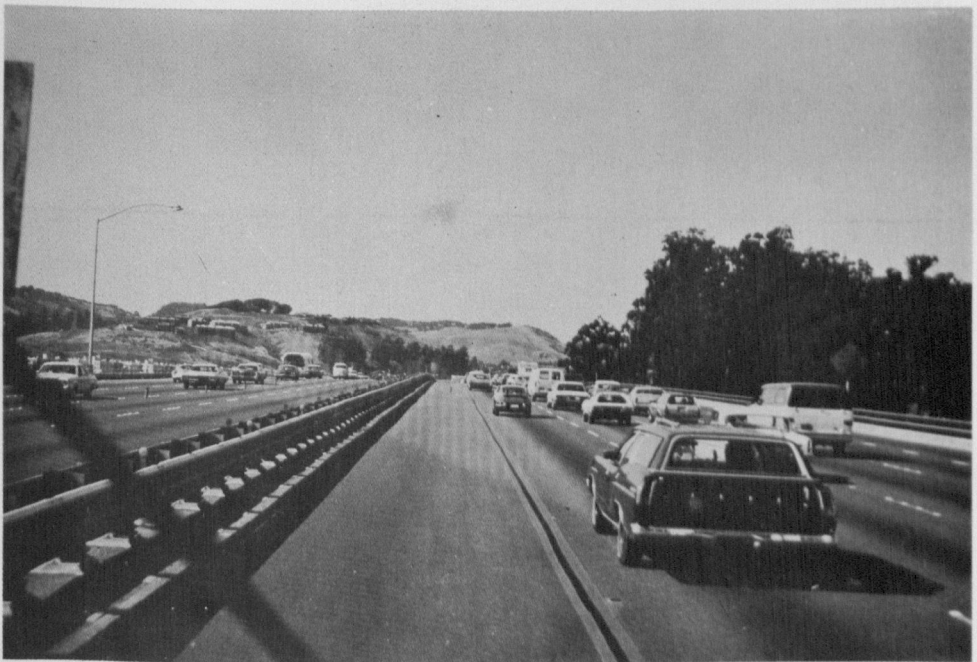

Figure 10. Bus lane on a freeway (San Francisco Bay Area)



Figure 11. Special lanes for buses and high-occupancy vehicles
(Los Angeles)



Figure 12. Bus/rapid transit transfer station

Trolleybuses, very quiet, smooth vehicles, were very popular about 30 years ago; then they nearly disappeared because transit companies were reducing costs, but overlooking such assets of trolleybuses as quietness, total absence of exhaust, and very smooth ride. With the increasing concern about the environmental conditions in cities, modern trolleybuses have been introduced in several Canadian cities (e.g. Edmonton (13)), in United States cities, (Boston, Philadelphia, San Francisco), and in many European cities (like the articulated trolleybus in Zurich (14)).

Light rail transit (LRT) has grown out of old-fashioned streetcars into a mode which offers a great variety of vehicles, types of rights-of-way and operations. Large double-articulated cars (15) are very common now. They are extremely spacious (with a capacity of over 200 spaces), quiet and very attractive for passengers. Some LRT vehicles have the options of high-level platform provided on some surface stations (16) and in all underground stations, and steps for the stops which are still in the streets and have low level boarding. The doors on these modern vehicles (sometimes up to five on each side) are all automated. Passengers can push a button and open them from the inside or outside (17). Each stairway has an electric cell. After some time, if the cell is not interrupted, the doors close automatically. Thus the driver alone controls the doors on two of these long cars without any safety problems.

The right-of-way vary from medians in streets to rights-of-way through parks with secured pedestrian crossings (18), or running in pedestrian malls (19). It has been proved in several cities that people like LRT in pedestrian streets because it brings them right to the buildings to which they are going, and again, they are quiet and do not disturb the pedestrian environment.



Figure 13. A modern trolleybus (Edmonton, Canada)



Figure 14. A modern articulated trolleybus (Zurich)

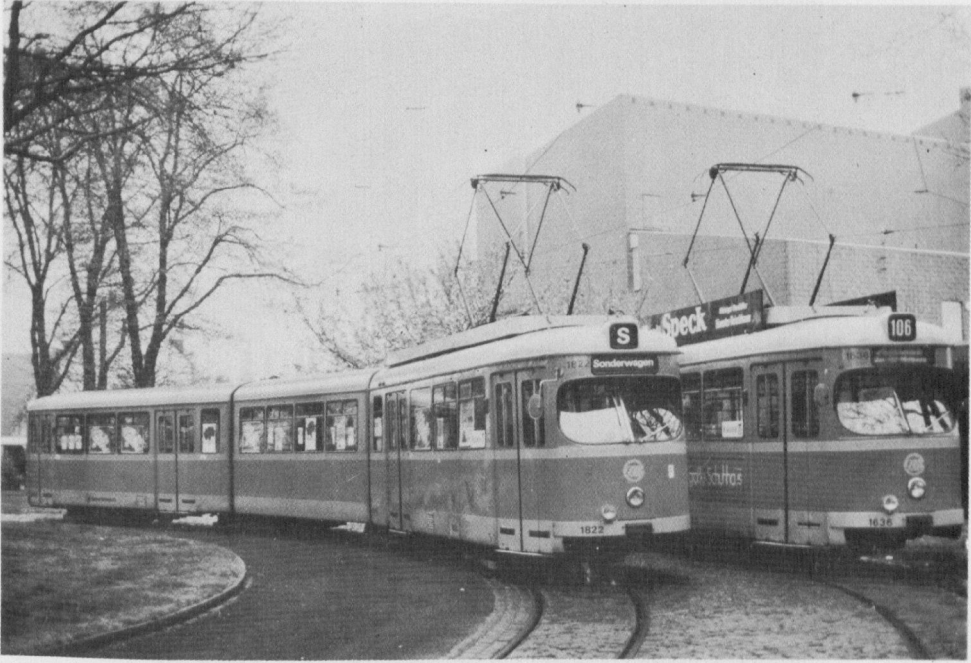

Figure 15. High-capacity light rail articulated vehicles (Ruhr, W. Germany)



Figure 16. LRT cars in Hannover (W. Germany) serve stations with high- and low-level platforms

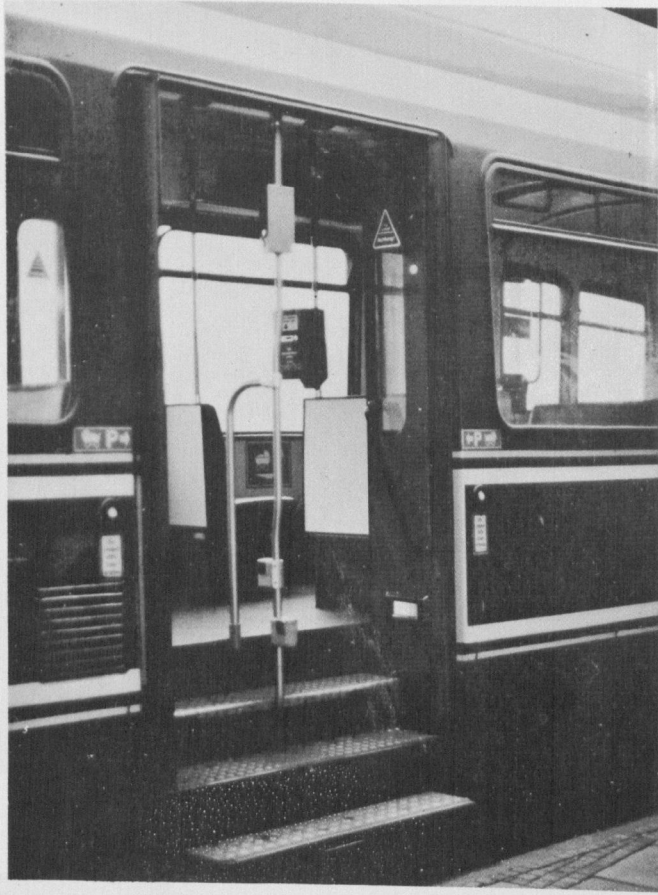

Figure 17. Automatic doors with buttons for activation by passengers and electric cell (W. Germany)

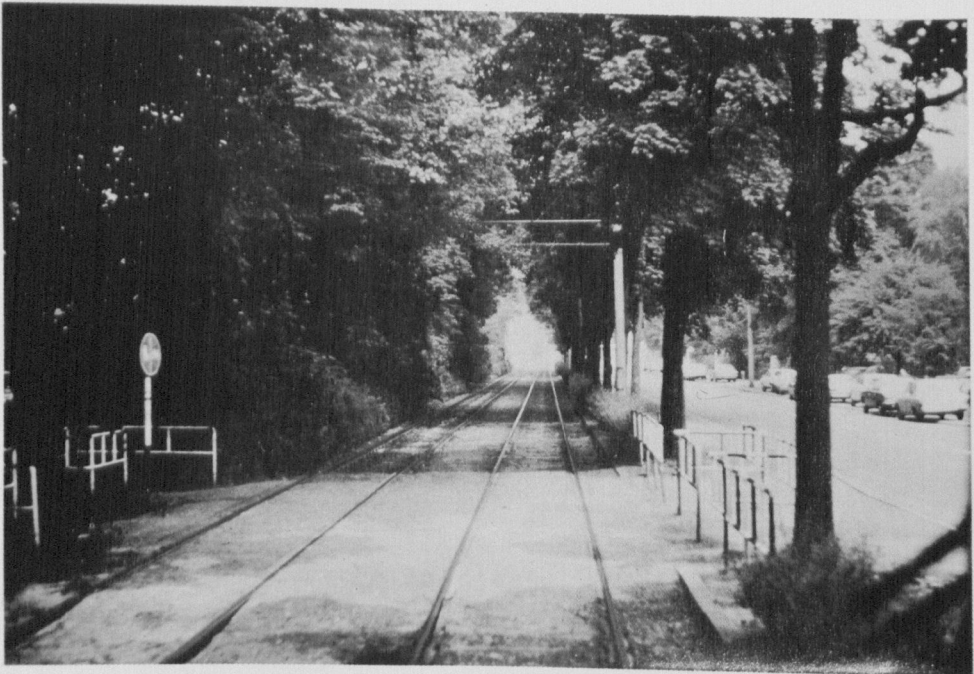

Figure 18. LRT right-of-way through a park (Hannover, W. Germany)

In San Francisco, streetcars running in congested streets have been upgraded into light rail through provision of private rights-of-way (20) and construction of a tunnel in downtown which has high-level platforms for faster boarding and alighting (21, 22).

Thus LRT systems can be built step by step from street running lines into lines which resemble rapid transit to a considerable extent. In (23) a line comes from a suburban area toward central city and goes in the tunnel for operation very similar to rapid transit (24). The construction of tunnels, like with rapid transit, is often combined with construction of pedestrian malls, shopping areas and very attractive downtown sections (25). In new residential areas in many German, Dutch, Swedish and Swiss cities, LRT lines are planned and built right from the beginning (26); therefore the right-of-way is very cheap and we are sure that there will always be reliable transportation independent from street congestion. Some lines in the Ruhr Region (W. Germany) represent a mode between light rail and rapid transit. Thus, there is a nearly continuous transition from one mode to another.

Light rail transit allows the networks to be upgraded step by step: first the most important sections in congestion areas, and then gradually, as the investment funds become available, extensions of the system are built, and in some cases, complete transition to rapid transit can be made.

If we look at rapid transit, i.e. full separation of transit right-of-way, we see a distinct jump in quality of service over LRT. There is also a jump in the investment cost again: we now have to build the system which has entirely separate rights-of-way, either as aerials or as tunnels. But, since the system is completely

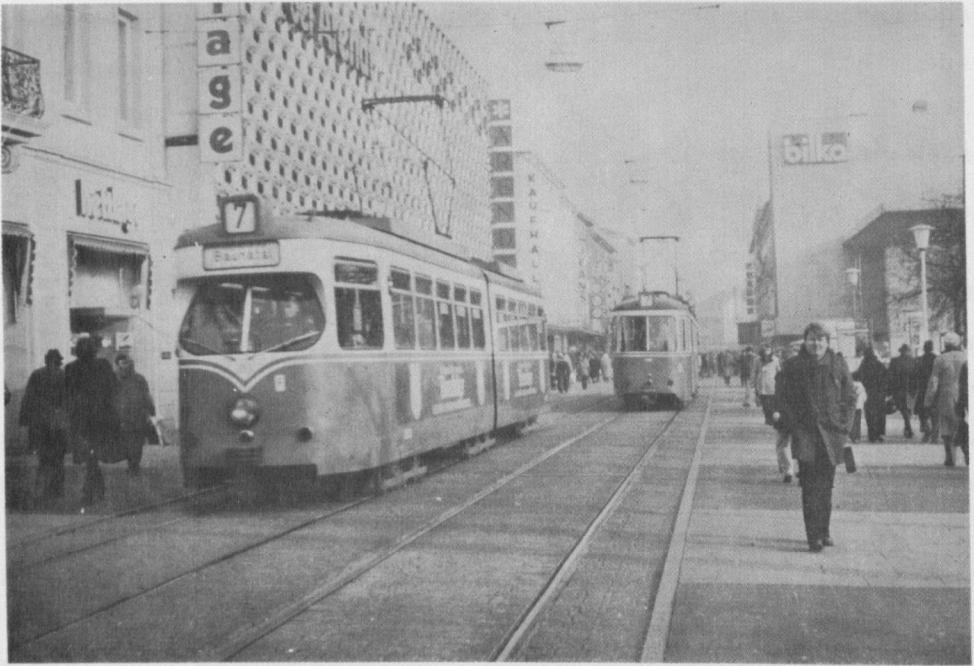

Figure 19. LRT in a pedestrian mall (Kassel, W. Germany)

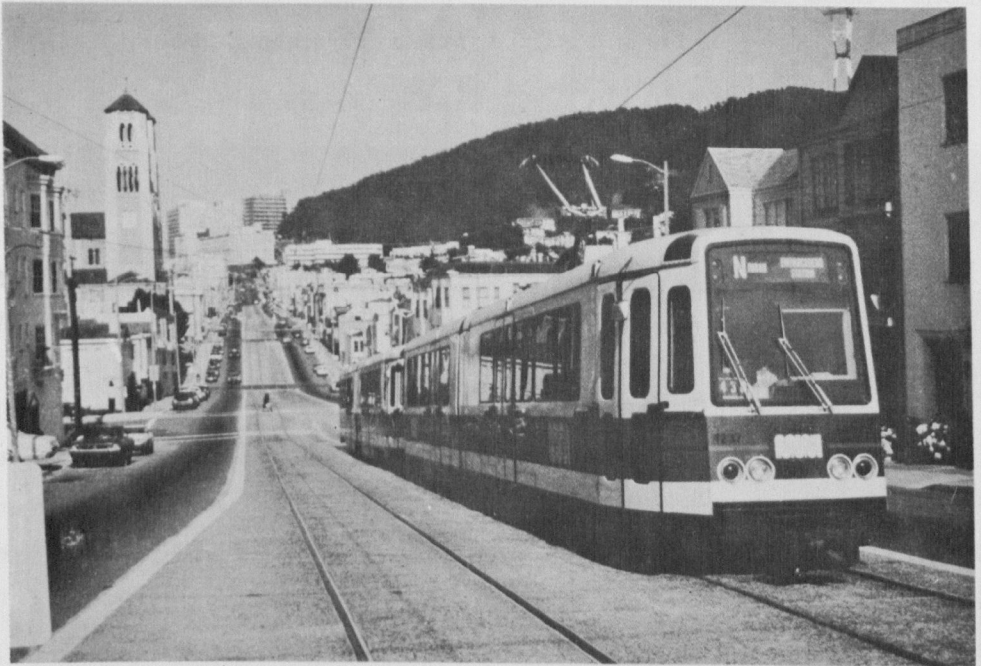

Figure 20. New LRT cars on recently separated right-of-way in a San Francisco suburb

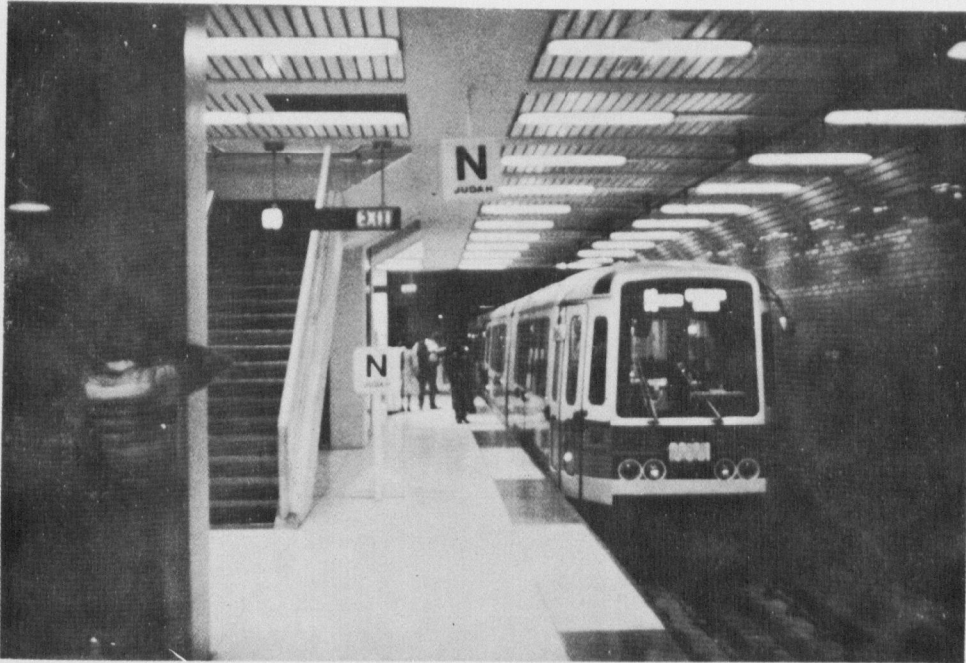

Figure 21. High-platform station in a tunnel in downtown San Francisco

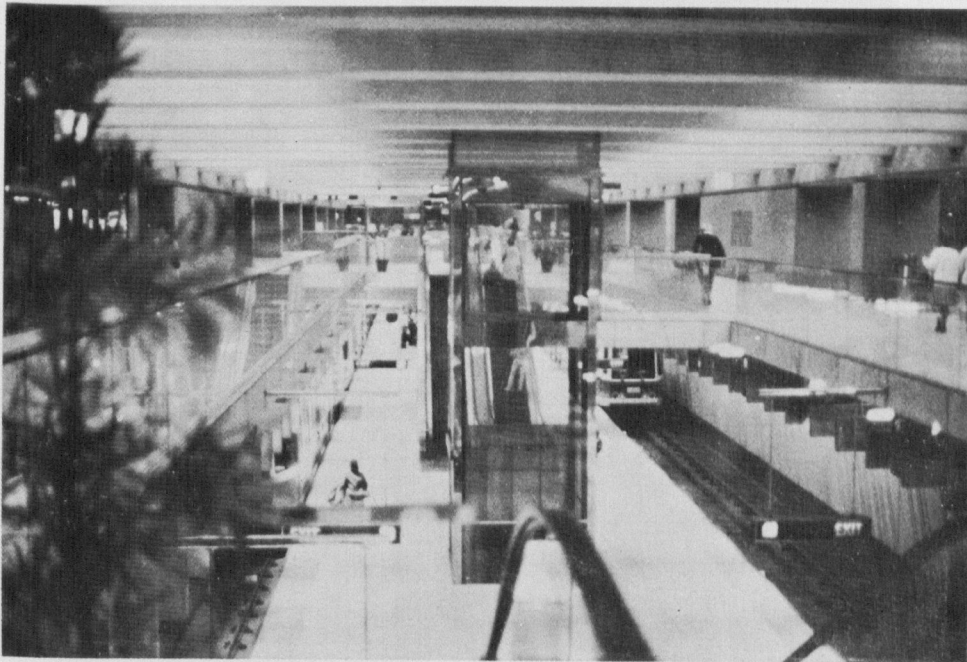

Figure 22. LRT/rapid transit (BART) station in San Francisco



Figure 23. LRT transition from surface to tunnel in Hannover, W. Germany



Figure 24. LRT underground station in downtown Hannover

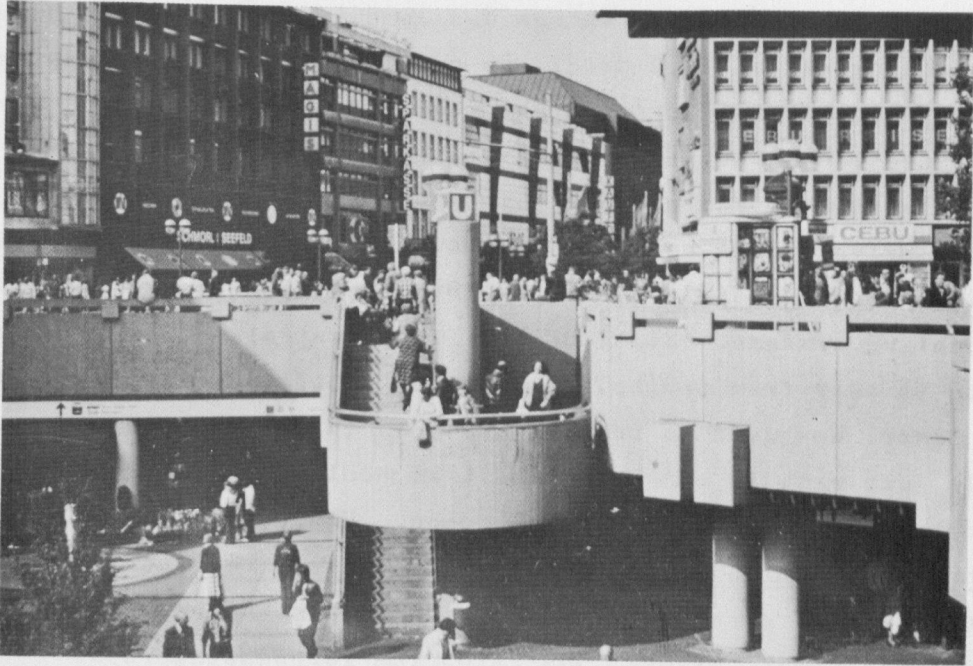

Figure 25. LRT station entrance integrated with pedestrian mall in Hannover

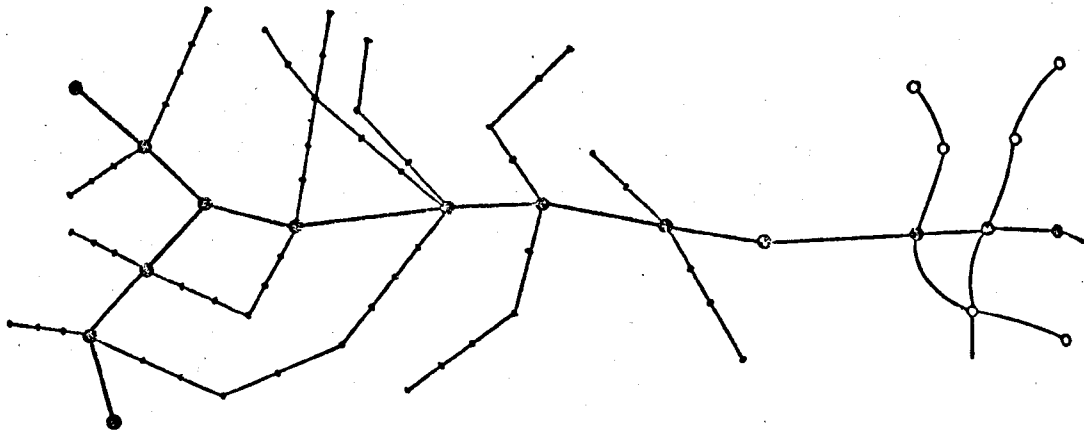

Figure 26. LRT line to a new suburban residential development (Bremen, W. Germany)

separated from other traffic, we can use long trains which can have 6, 8 or 10 cars instead of 1, 2 or 3. We can operate at higher speeds, as high as we technically can, rather than limited by safety on streets or at intersections. We increase safety because we signalize the entire line with a so-called fail-safe mechanism; that means that even if the driver makes a drastic mistake, there cannot be an accident. Practically absolute safety can be achieved on these systems with automatic signaling systems. Stations are fully controlled, so that fare collection is away from trains. High level platforms, i.e. equal level with car floor, are used so that we can open up 20-30 or 40 doors and let people just walk in and out without any delay. That means drastically increased capacity, speed, and so on. Practically, the ultimate method for transporting large volumes of people is thus achieved: high-capacity units carrying large volumes of passengers, going as fast as the alignment allows, just stopping for passengers at stations, no other delays, no causes of irregularities. So we are paying the most in investment and we are getting the highest type of transportation mode. When there are high passenger volumes, rapid transit offers the lowest cost per passenger, due to its very high capacity and operating efficiency.

This review of transit modes shows that they are characterized by three different elements: first, type of right-of-way (street, partially-separated, or fully-separated); second, technology of ways and vehicles; and third, type of operations.

Rail rapid transit in general has very distinct lines with stations, so that it has the simplicity and image which attract people. The upper part of Fig. (27) shows a rail line with many bus feeders to its stations. The lower part shows typical set of commuter bus routes: they come from many directions and go into the city.



(a) Regular transit: high-frequency, trunk-line service, transfers to feeders; all-day service

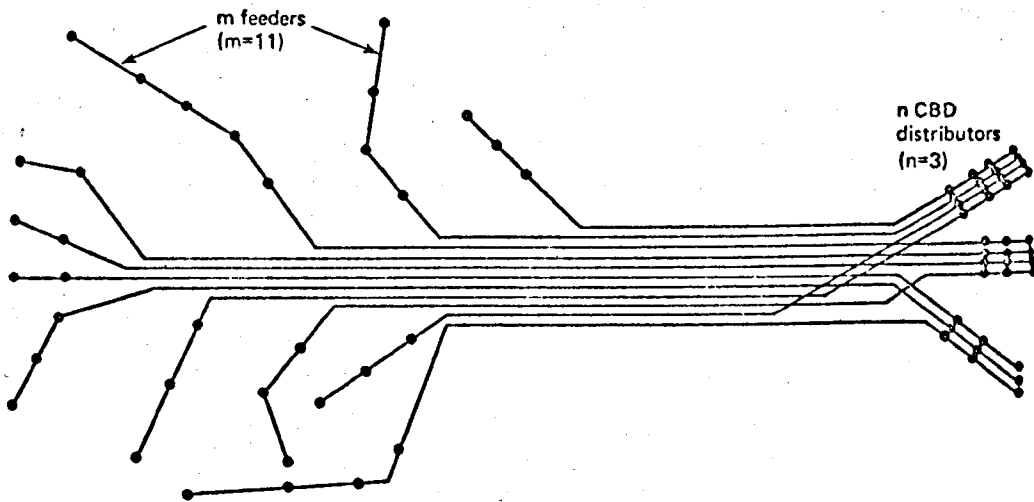

(b) Commuter transit: feeders travel directly to CBD; no transfers; low frequency, no service along trunk section; peak-hour service only

Figure 27. Corridor service by regular transit (typical for rail) and by commuter transit (typical for express bus)

They serve commuter traffic efficiently, but they cannot serve travel between different points and from any one point to any other point.

An interesting situation exists in eastern suburbs of Philadelphia: buses serve an extensive network of lines, while one rail line (the Lindenwold Line) has only eight suburban stations(28). Yet, the rail line attracts 30% more passengers than all the bus lines. The reason is the more distinct and higher quality service which rail provides due to its excellent right-of-way and superior technology (electric rail vehicles). It is pointed out again: right-of-way is the main element determining quality of service; technology is largely a result of it: the more we go to separate rights-of-way, the more advantageous are the rail modes. With full separation rapid transit is the optimal technology to provide the highest performance and the greatest operating efficiency.

If we plot the entire family of transit modes on two different diagrams (29), we can see some interesting relationships. On the first diagram, vehicle/train capacity is plotted on the abscissa, and maximum frequency of service on the ordinate. One can see that the modes operating on streets have the smallest capacity units, but the highest frequency. With semirapid transit frequency decreases, but capacity of units and speed increase. In the third group we have rather low frequency with rapid transit (we cannot exceed approximately 40 trains per hour), but the units have a capacity of 400 to over 2000 spaces. Total capacity and speed of the line are again greatly increased.

The second diagram shows the general relationship of modes with respect to their investment costs (on the ordinate) and performance (on the abscissa), which is expressed through capacity

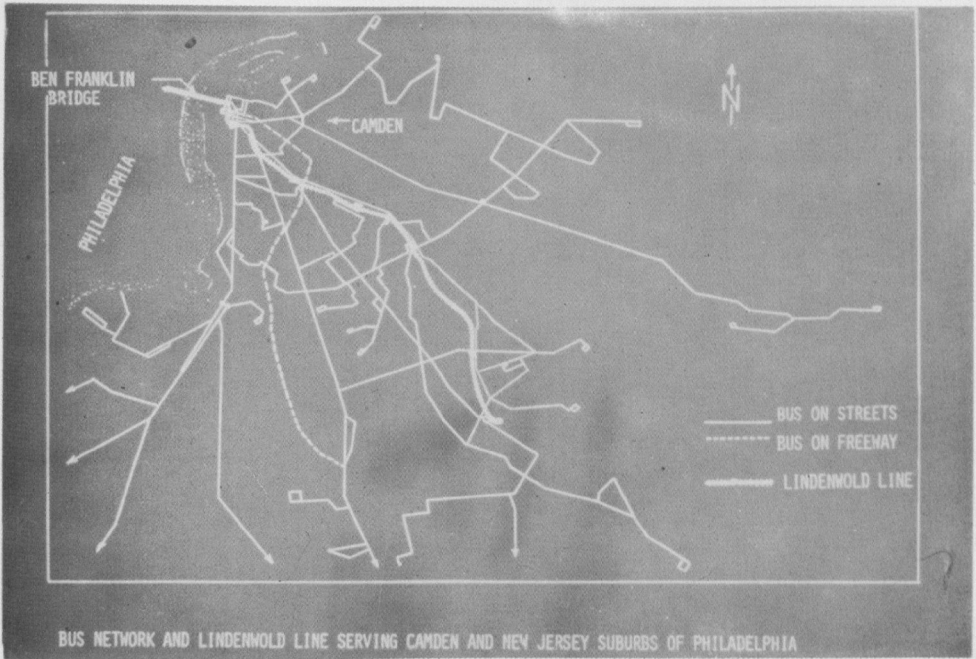

Figure 28. Bus network and Lindenwold Line serving New Jersey suburbs of Philadelphia

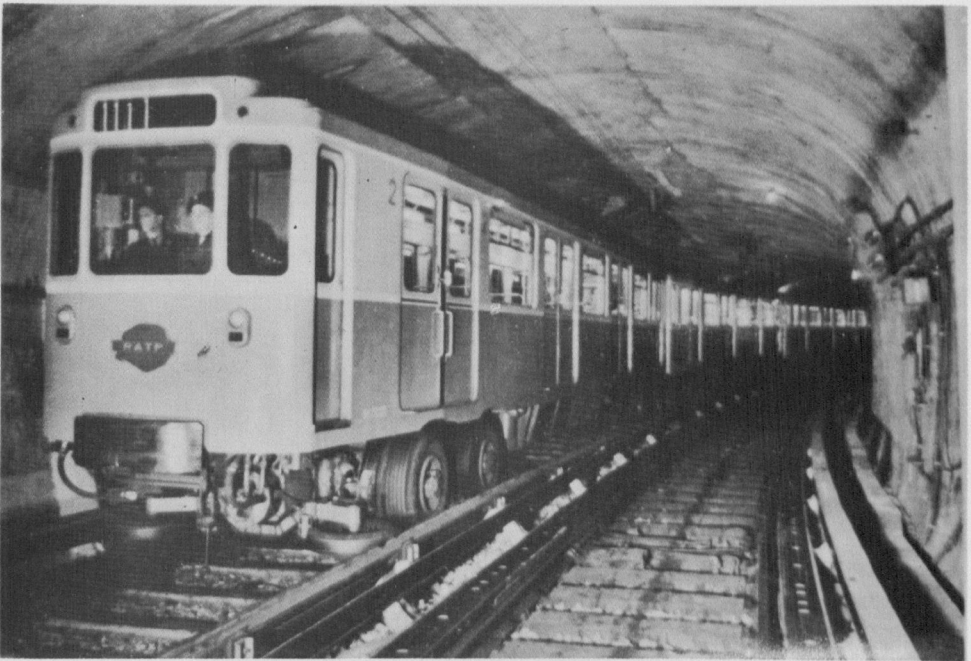

Figure 30. Rubber-tired rapid transit in Paris

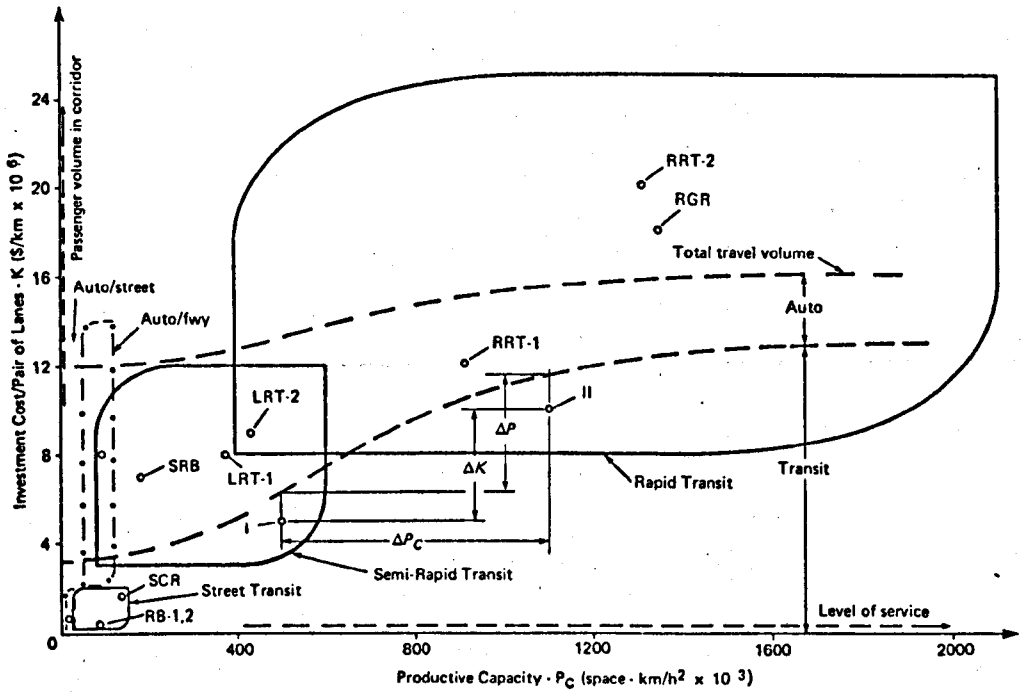
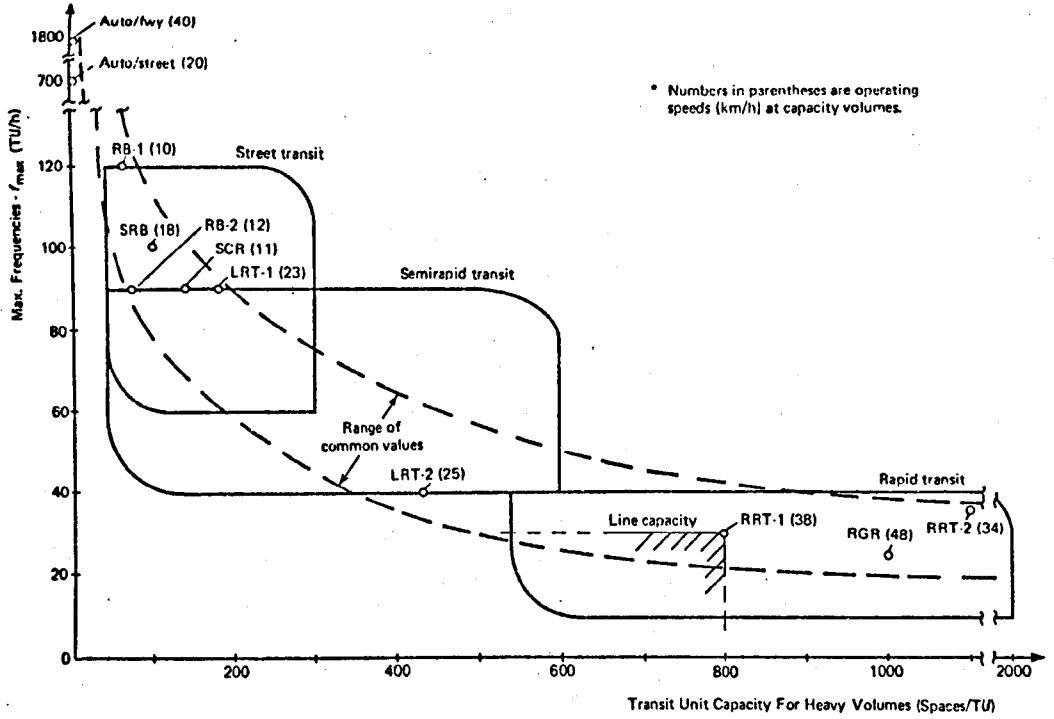

Figure 29. Physical, operating performance and cost characteristics of street transit, semirapid and rapid transit

and speed. The small box at the bottom represents street transit. Then, semirapid transit has higher performance and higher cost; and finally, rapid transit is represented by the largest box since it includes a great variety of systems: from rather low capacity, such as on the Paris Metro, to the high capacity as the Hong Kong rapid transit.

Let us now review different technologies for rapid transit. In Paris, rubber-tired rapid transit was introduced in 1956 (30). The idea was to reduce noise increase speed through higher acceleration rates, and have a softer ride. However, that was done at the time when rail transit was rather primitive. Since that time rail transit has become very much perfected: its noise has been reduced or eliminated, its acceleration rate greatly improved. This rubber-tired rapid transit has, in addition to each steel wheel, a riding rubber-tired wheel running on a beam, and a horizontal rubber-tired wheel which guides the vehicle against a vertical board(31, 32). Steel wheels and rails are still there for switching and for carrying the vehicle in the case of tire failure. This technology has been used on rapid transit systems in six cities: Montreal, Mexico, Santiago, Lyon, Marseille, as well as for some lines of the Paris Metro. In most cases this system was found to have only marginal improvements, but rather significant deficiencies compared with conventional rail. It cannot operate outside on inclement weather, wet or especially snow and ice. Its noise is not lower than the noise of modern rail systems, except in curves, where rubber-tired technology still has an advantage. It produces considerable heat, uses more energy, and it limits vehicle size because of the limited load-carrying capability of tires.

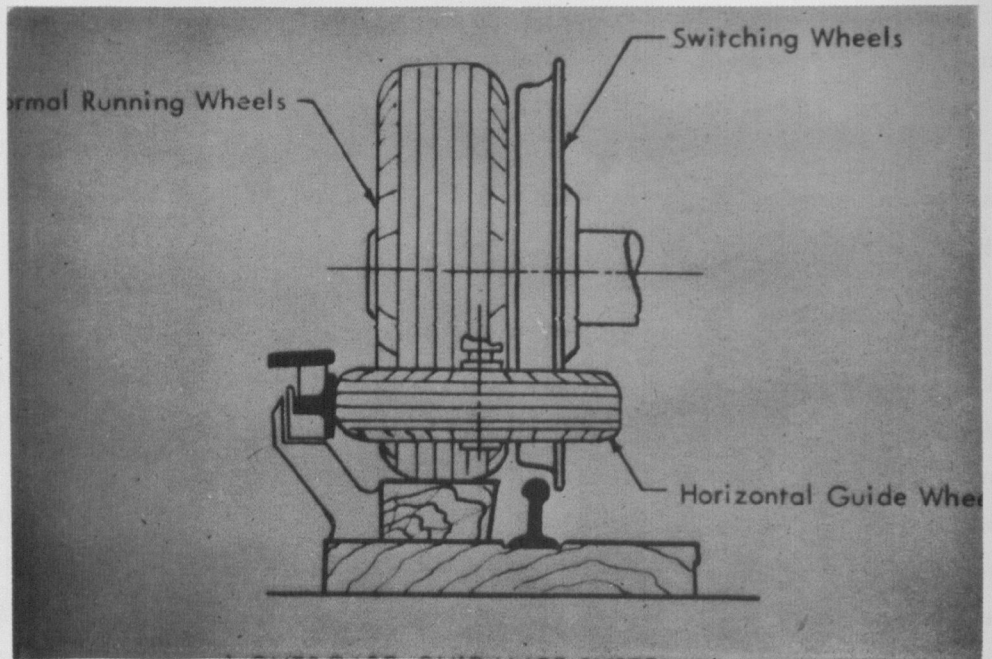

Figure 31. Support and guidance mechanism for rubber tired rapid transit

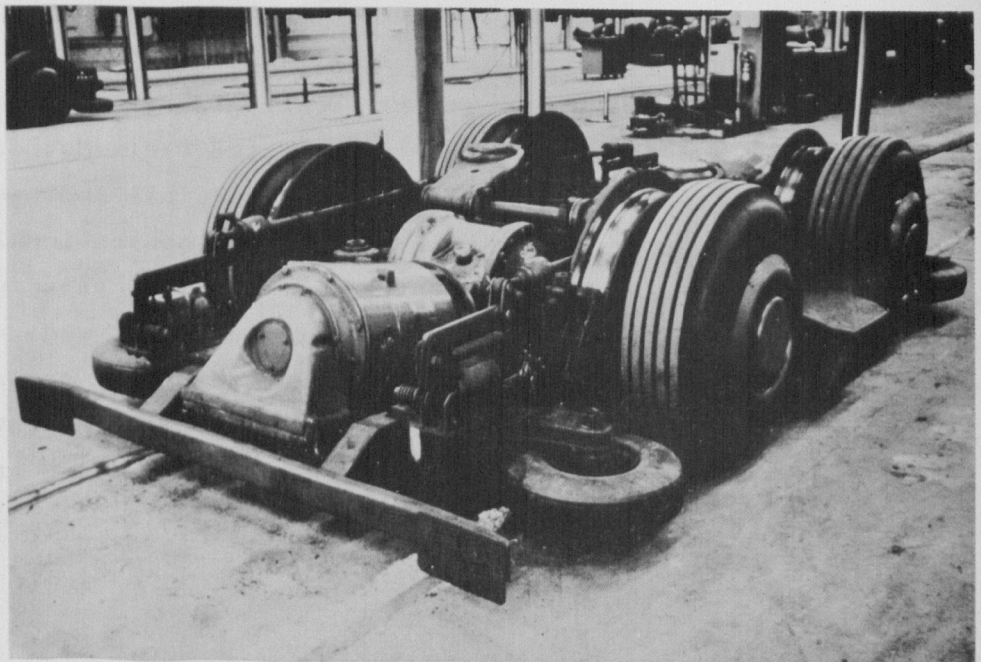

Figure 32. A rubber tired rapid transit truck

There were extensive discussions about monorails at one time. They have the advantage of light guideway, as the cross-section of the Seattle monorail (33) shows. However the vehicle body has to straddle the guideway to be stable. So it has six wheels in one set, instead of two, as rail systems do. Switching is slower, vehicles smaller. Yet, a comparison of cross-sectional areas (34) for rail (on the left), monorail riding on a beam (center), and monorail suspended from a beam (right), shows that on the ground level (top), on aerial structures (middle) and in the tunnel (bottom), the rail system requires the smallest profile. In addition to that, it is technically much simpler and operationally better.

There is one monorail which has operated for 80 years very successfully in the city of Wuppertal in W. Germany. It is a unique line along a river (35), and it is very successful in that city, but there are no plans to use it elsewhere.

There was a period of developments of many new transit modes, particularly automated guided systems. "Personal rapid transit", with small cabins (36), has some interesting technical features, but this mode has no realistic chances for application in urban transportation.

Among the "group rapid transit" modes there are a variety of systems, and some of them are finding increasing applications in short-haul transportation in airports, various shuttles, or short lines serving limited areas. Figures (37, 38) show the Skybus (or Transit Expressway), which can run as a single vehicle or in trains of several vehicles with full automation. This system, and several similar ones, operate in a number of airports, fairgrounds, etc., and their use will increase, but not for major transit lines.

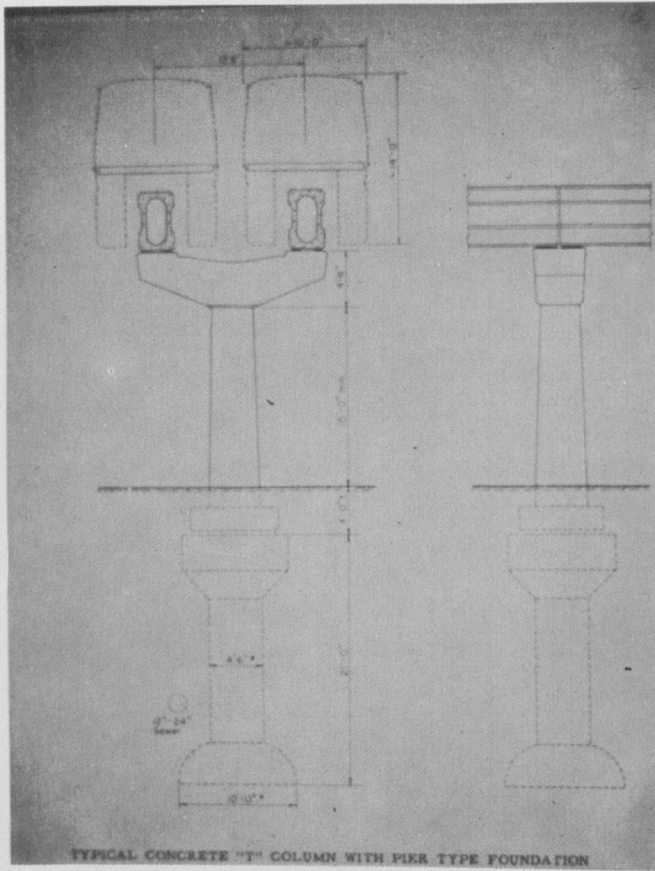

Figure 33. Cross-section of Alweg monorail in Seattle

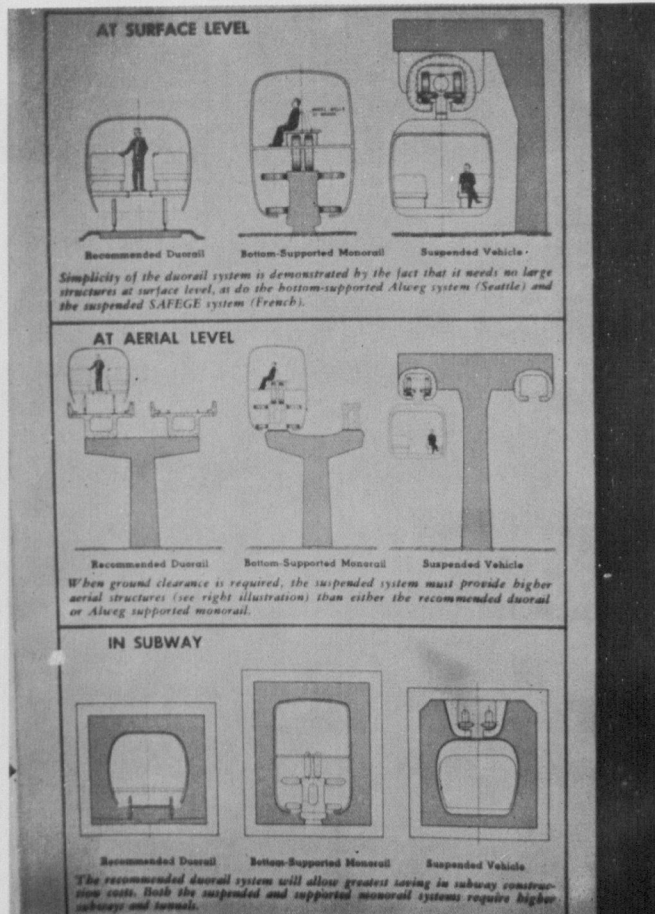

Figure 34. Comparison of cross-sections for rail and monorail technologies

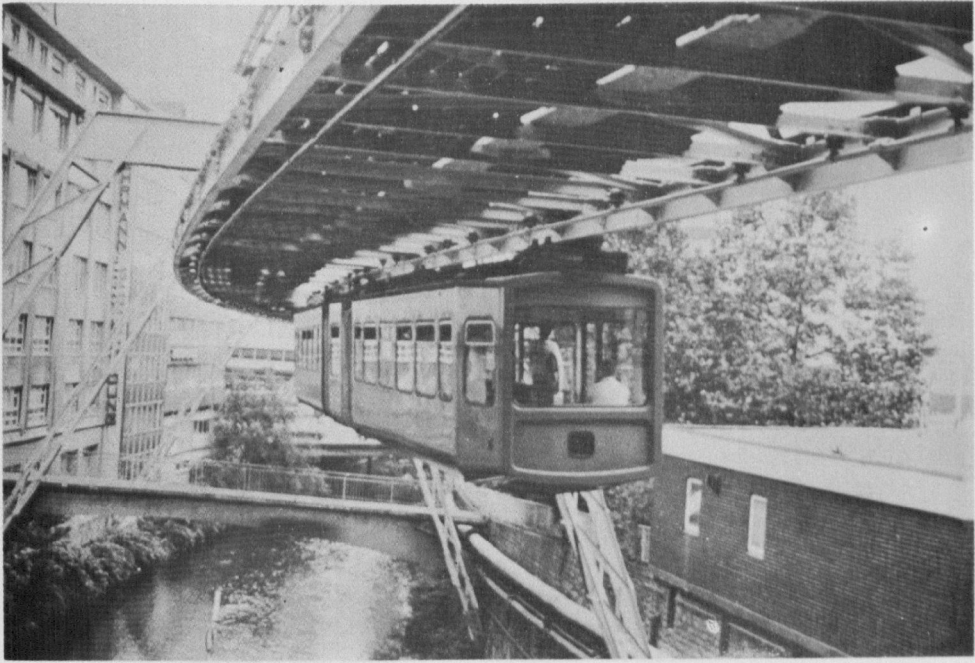

Figure 35. Wuppertal Schwebebahn (monorail)

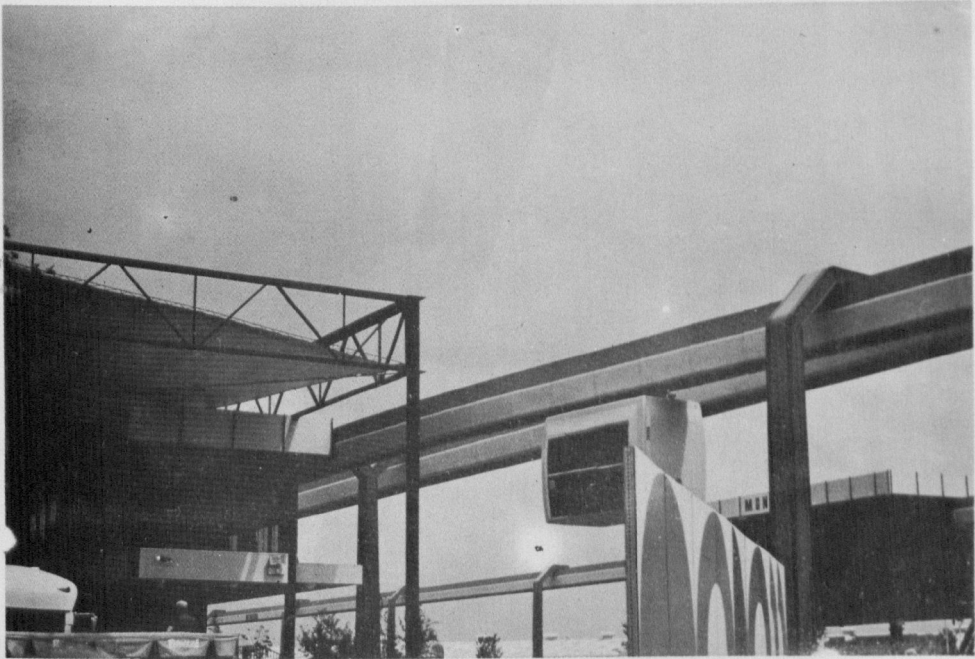

Figure 36. Personal rapid transit - an unrealistic concept

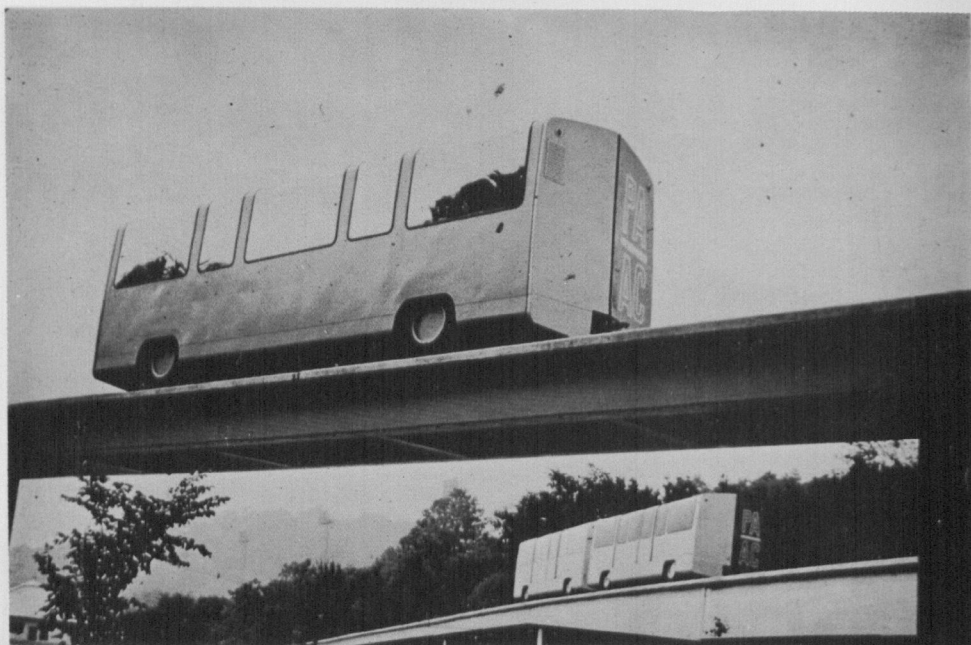

Figure 37. Skybus vehicles on aerial guideways

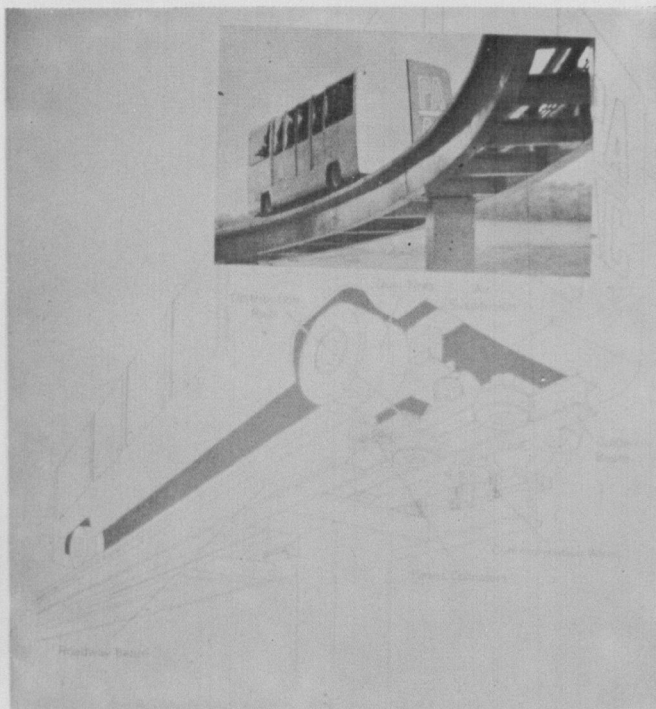

Figure 38. Skybus guidance technology

Rail rapid transit is being built now in many cities with tunnel, aerial, and, in some cases, at-grade rights-of-way. Many components of rapid transit have been improved greatly in recent years. Several decades ago systems were built which had very tight radii (50 or 30 meters), and gradients of 5 or 6%. In recent years there was a trend to use higher and higher geometric standards, so that 4% was very common. On some systems minimum elements were 1.5% gradients and 300 meters radii. Such elements are unrealistic, since they cost a lot in terms of not being able to achieve alignment required in cities. Consensus is now converging somewhere toward the middle values between the excessively low and excessively high geometric standards.

With respect to station types, there is a great variety. A strong tendency is to achieve integration of stations with the surrounding buildings, pedestrian concourses and, especially, integration with other modes. Signalization has gone from electric automatic block signals, which are operationally quite satisfactory, but do not offer very sophisticated control. Several new systems tried full computerization, but it has been successful in some cities, and not very successful in others. There is now considerable caution among experts as to whether a very high degree of automation is needed in all cases. Do we need to fully automate train travel if we still have a driver? He then has nothing to do. Actually, there is a problem that drivers tend to doze or fall asleep; London has therefore gone back from full automation to partial automation in driving. We in the U.S. also have some not very good experiences with excessive automation.

The capacity of rapid transit is generally very high, but its exact value depends on vehicle size, train size, type of controls,

and other factors. We are usually talking about round numbers, but really the capacity varies greatly and it should be studied in the planning stage very carefully. Design capacities of 50,000-60,000 spaces per hour, or even somewhat higher can be provided.

With respect to network forms there are opinions that rapid transit should not have very many branches: only up to two branches are desirable. However there are systems with up to 4, 5, or even 6 branches which operate satisfactorily. Very careful planning and operational competence are required in such instances. Branches are functionally very good because the lower density areas in suburbs get lower frequency of service, while higher density gets higher frequency and capacity. The forms of network in some cities used to be focused heavily on one point, i.e. the central city was the point of convergence. More and more cities are now concluding that it is better to use diametrical lines running through the city, with two carefully balanced sections. The lines cross each other at different locations within the central area, so that the high-density areas have considerable coverage by a number of stations. The coverage of the city is important and with well planned transfers, people should be able to travel conveniently from any station to any other station. With careful planning of bus (light rail, trolleybus) feeders we get a system which has a skeleton of rail transit with branches and feeders in lower densities of service.

In terminals integrated fares and integrated information must be provided. Coordination with long-distance bus and rail services, such as you are planning for Taipei, is a very desirable element.

Rolling stock has a great variety of features. Light rail presently almost always uses articulated vehicles which are practical

for high capacity. Rapid transit seldom has articulated vehicles, but there is a variety of car sizes; 18-meter long vehicle is about the shortest now used in new systems. The longest are about 23 meters. Widths are from 2.65 to 3.23 m. Married pairs and single units are often combined to have rolling stock allowing operation of trains from one car to any number of cars, up to the maximum train length. Lighter weight and greater efficiency with respect to energy are also becoming very important features.

Let me now review examples which will show a variety of rapid transit systems. In Rotterdam, the rapid transit line is elevated most of the way (39). A very quiet, nicely designed and rather simple system. Toronto also has a simple, very well operated system, fully integrated with buses, streetcars and trolleybuses. Its construction had a strong impact on intensified land use development around stations. It has very large vehicles (40). In London there are two types of rolling stock. There is the so called "Underground", which is built by cut-and-cover method from surface and has fairly large vehicles (41). The so-called "Tube" stock is much smaller (42), since its tunnels have a diameter of only 12 feet (3.66 meters). Many old systems have been renovated. In Paris under the Louvre some exhibits have been placed in the Metro station (43), so that passengers waiting for trains can "visit" parts of the museum. Hong Kong rapid transit (44), opened in 1979, carries 550,000 passengers/day. An interesting feature is overhead wire instead of third rail. The very large cars have continuous interior: in this case rapid transit uses articulated bodies. Rapid transit systems in Japan also use continuous train interiors extensively, facilitating passenger distribution throughout the train (45). Reliability of rolling stock is required for this design, so that trains do not have to be uncoupled under normal conditions.



Figure 39. Aerial station on the Rotterdam Metro system



Figure 40. Toronto rapid transit

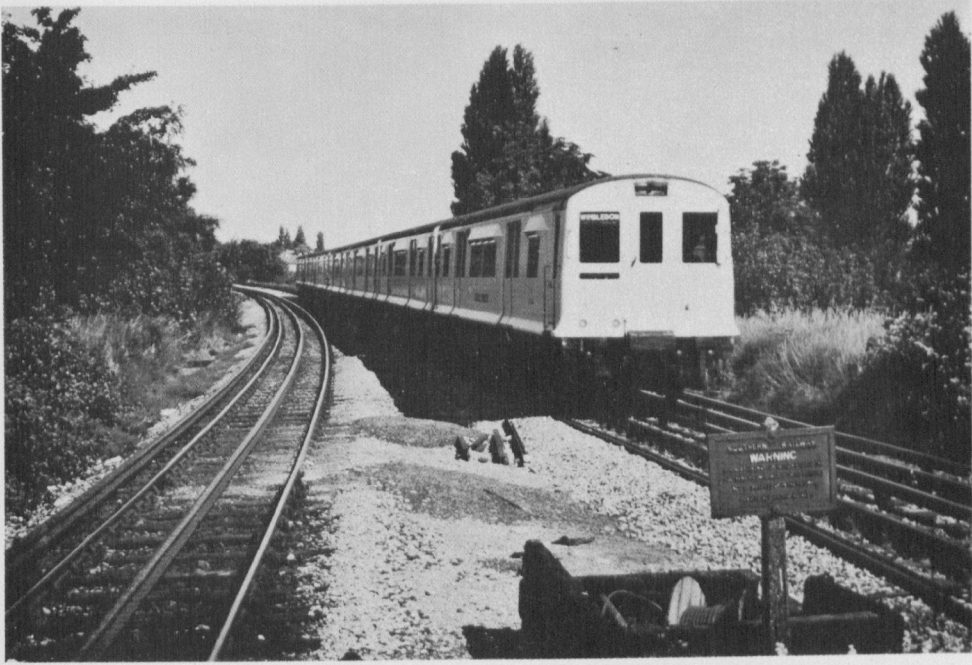

Figure 41. "Underground" rolling stock in London

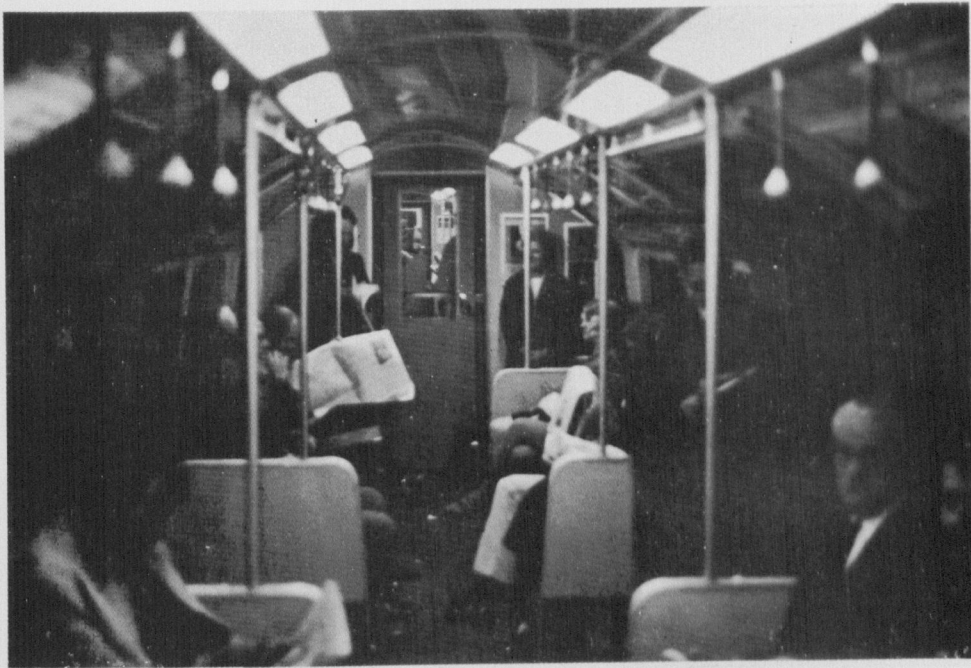

Figure 42. Interior of the "Tube" rolling stock in London



Figure 43. Louvre Metro station in Paris



Figure 44. Hong Kong rapid transit



Figure 45. Continuous interior in a rapid transit train (Yokohama)



Figure 46. Lindenwold Line rapid transit in Philadelphia

The Lindenwold Line in Philadelphia (46) has been extremely successful in attracting people. One of its unique features is the window in the front (47). Passengers can sit and look forward, instead of facing a blank wall, which is the case in most rapid transit systems. People like this very much. The driver sits in an open cabin (48). Mexico City built an excellent system with simple, and yet well maintained and attractive stations (49, 50). One problem of their Metro is that rubber-tired system is used, which allows only small vehicles. Since their capacity is already exceeded, the city must build more lines than if rail technology with large cars was used. Montreal built rapid transit as a part of modernization of the central city. Its rapid transit is connected with stores, pedestrian concourses, and every station is attractively designed, different from the other (51, 52). Montreal city fathers decided that they wanted to pay a somewhat higher investment to have a very attractive system. Munich has been building its subway since the late 1960s. It is an extremely quiet, beautifully designed system.(53).

Escalators are increasingly used, but sometimes overused in rapid transit stations. In some cases there are escalators only, no stairways. Experience has been that this may result in problems if the escalators break down: people do not like to walk over them; it is better to have regular stairs. Transfer stations with buses often have automatic ticketing machines and a self-service system with people cancelling their tickets and walking in without any delays (12). In San Francisco, BART has featured extremely comfortable cars (54), beautifully designed station (55), and very sophisticated control (56) (which actually created some problems because it had not been adequately tested). BART pioneered many new things like extremely high speed, very high comfort, etc. Integration of light rail and BART is made in several stations under Market Street in San Francisco (22). The Washington Metro is one of the most recent highly successful rapid transit systems, carrying over 300,000 passengers/day (57).

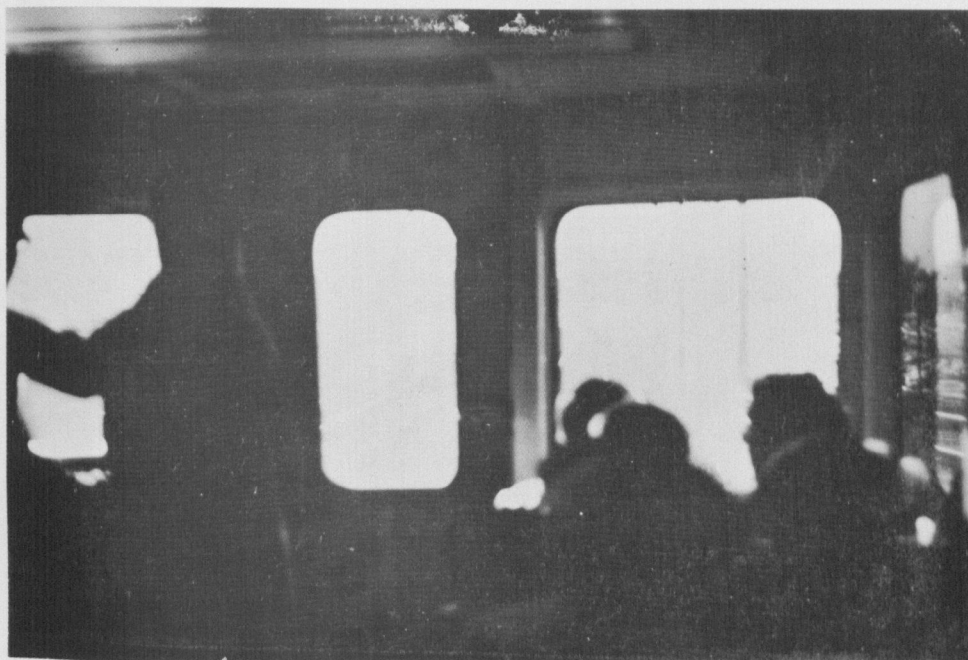

Figure 47. Passengers have a front view in Lindenwold Line cars



Figure 48. Open driver's cabin (Lindenwold Line)



Figure 49. Mexico City Metro

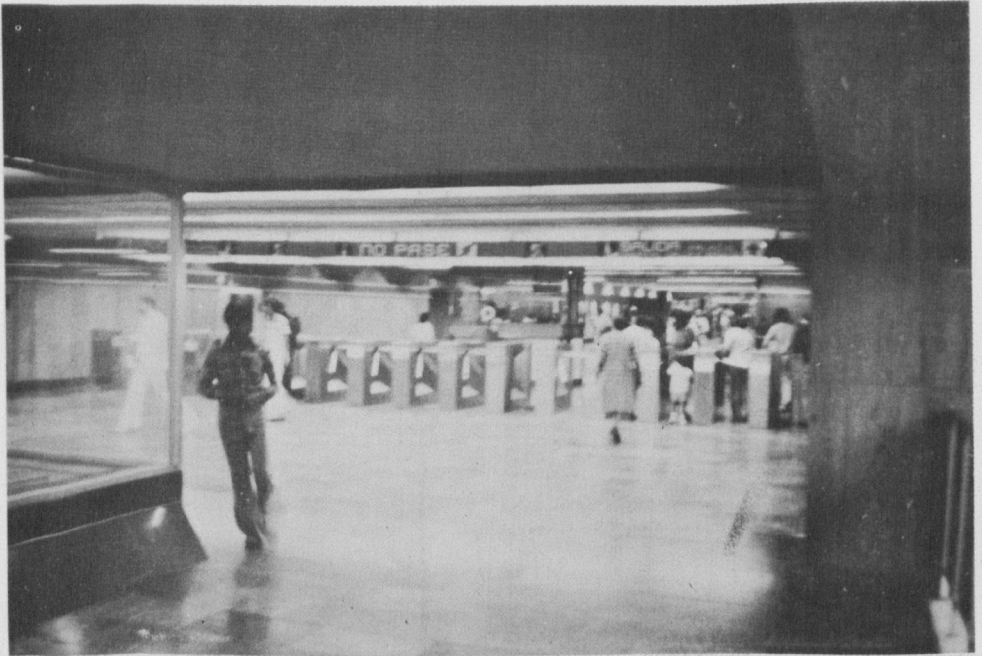

Figure 50. Metro station in Mexico City

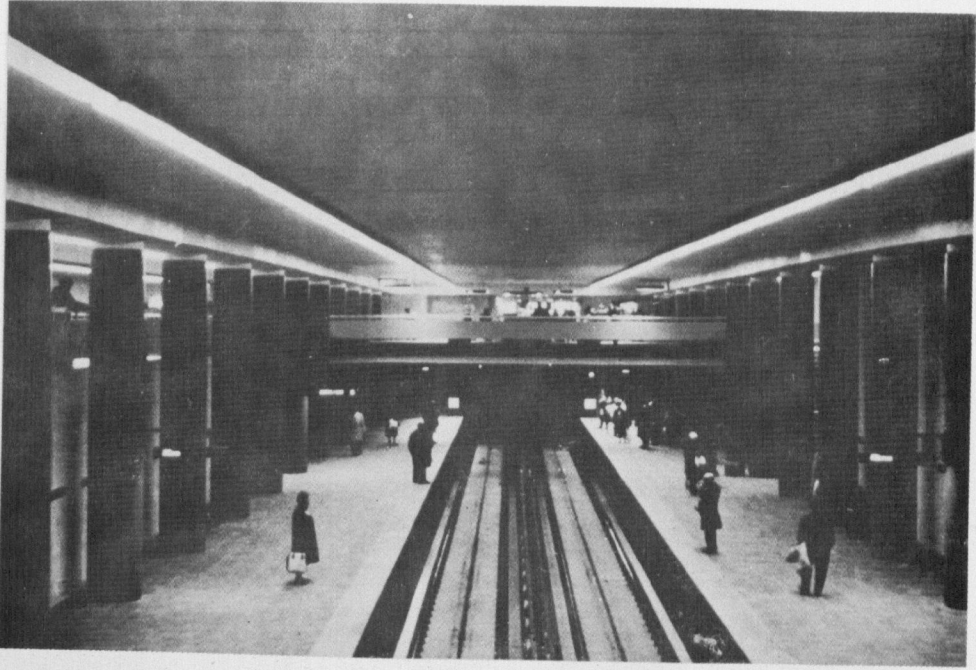

Figure 51. Montreal Metro station



Figure 52. Ornaments in Montreal Metro



Figure 53. Munich U-Bahn

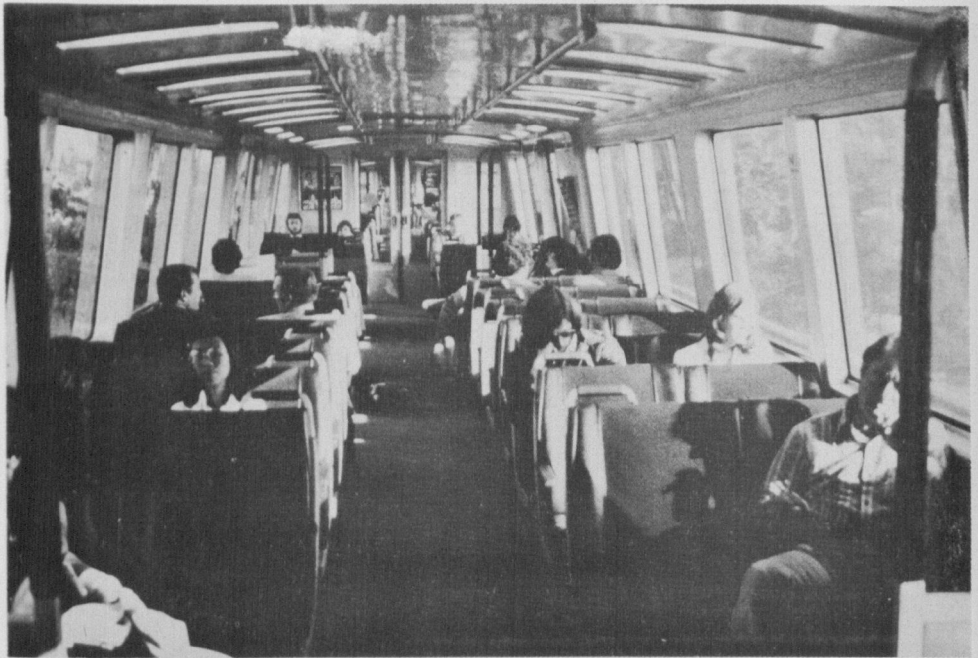

Figure 54. San Francisco BART car interior

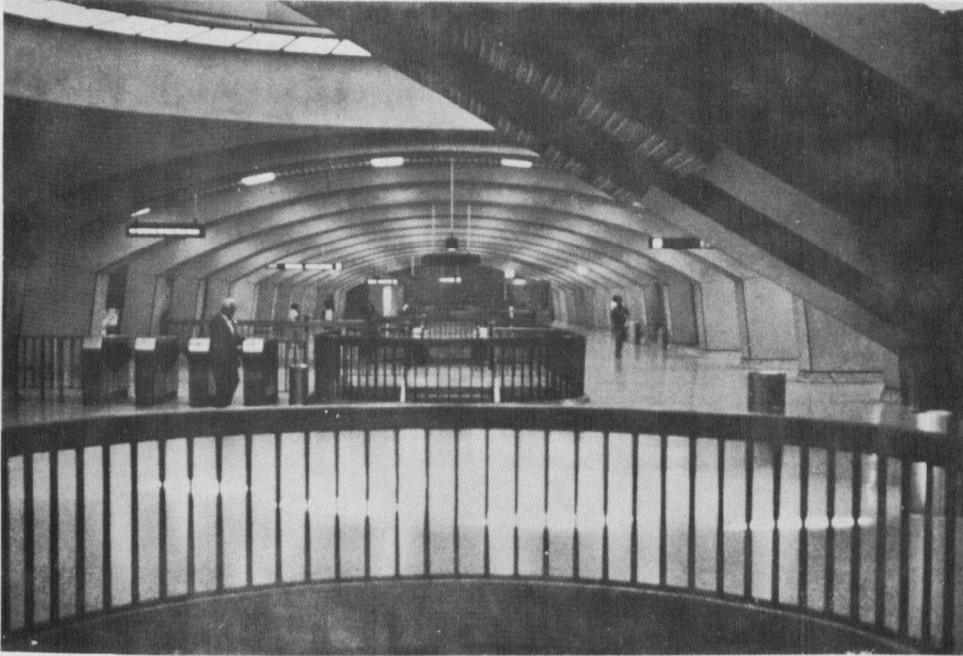

Figure 55. BART station mezzanine

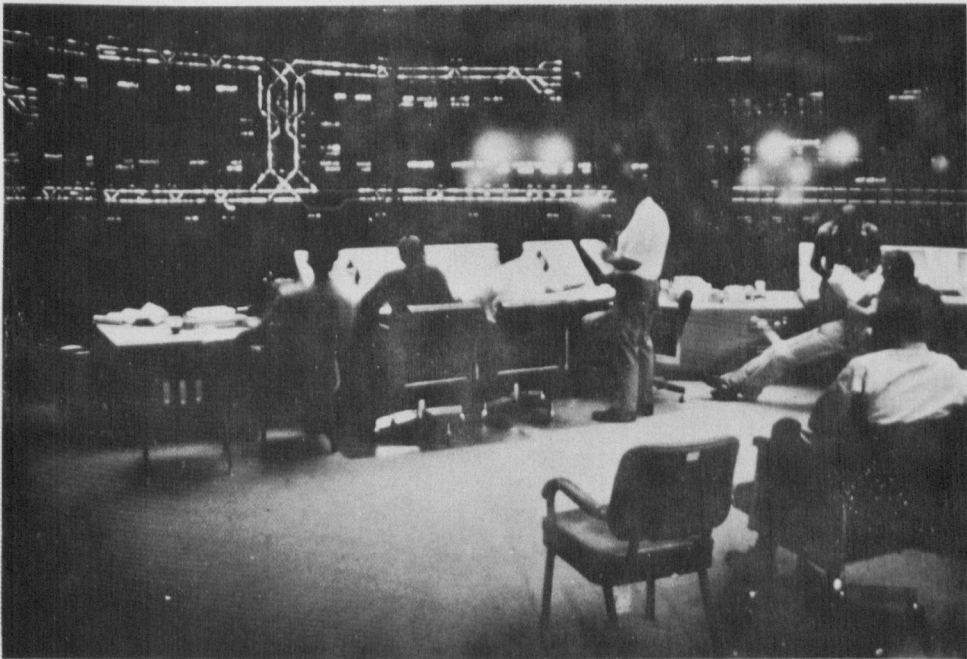

Figure 56. BART control center

The most common methods of tunnel construction is "cut-and-cover", from the surface (58). In most cases the street is closed, and traffic must be diverted. The cover-and-cut, a different method of construction, is used in a few cities, like in Caracas: it requires a shorter street closing period. However, Edmonton, constructing a tunnel for light rail, managed to close the street to traffic for only 14 weeks. It does not have to be two years of construction, as happened in some cities! The tunnelling (boring) method of construction (59) is in some cases advantageous if the tunnel must be deep. In general however, it is much better to have tunnels closer to surface, to reduce passenger access times.

In the United States we have buses and park-and-ride as the most common rail transit feeder modes (60). In Japan "bike-and-ride" is very popular: people leave bicycles and take rail rapid transit or regional rail into the city (61).

In virtually all cities, rapid transit has been very successful in attracting passengers and in changing the character of the entire city. In most cases rapid transit acts as the basic, "skeleton" network, supplemented by various street transit and paratransit modes. In some cities rapid transit offers extensive area coverage. In Paris the Metro network grew continuously since 1900. Until 1933 it extended only to the city limits. Twenty years later some lines were extended beyond these limits, and they are now continuously being extended farther. The area coverage in the city is nearly 100%, if we use 400-meter radius around the station, or 5-minute walk, as the definition of coverage.

Regional rail has been improved in many cities and integrated closer with other modes. In Munich (62) six lines on one side and five lines on the other side of the city have been connected through

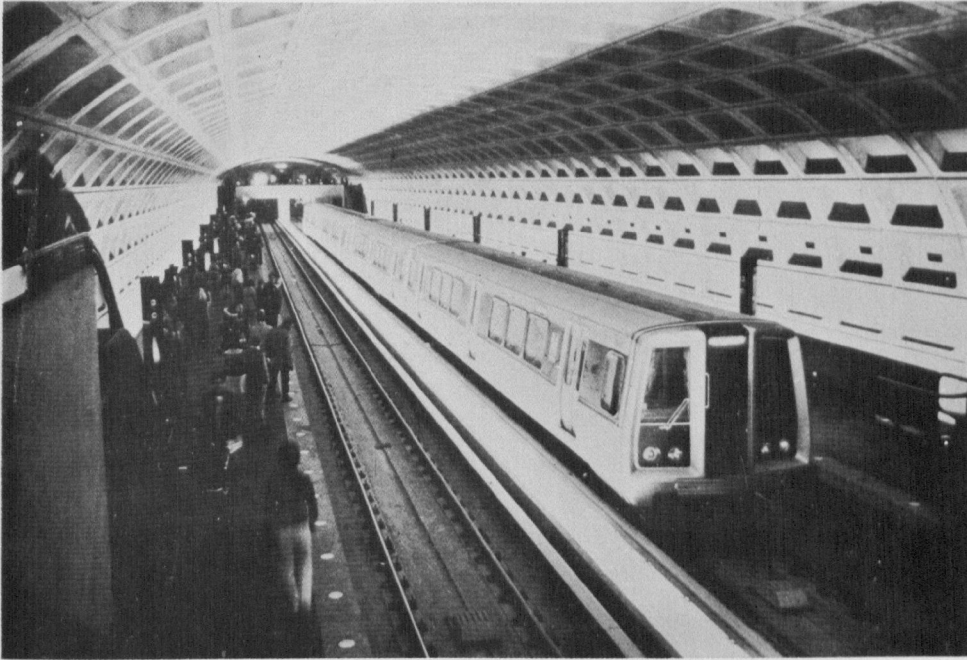

Figure 57. Washington Metro station

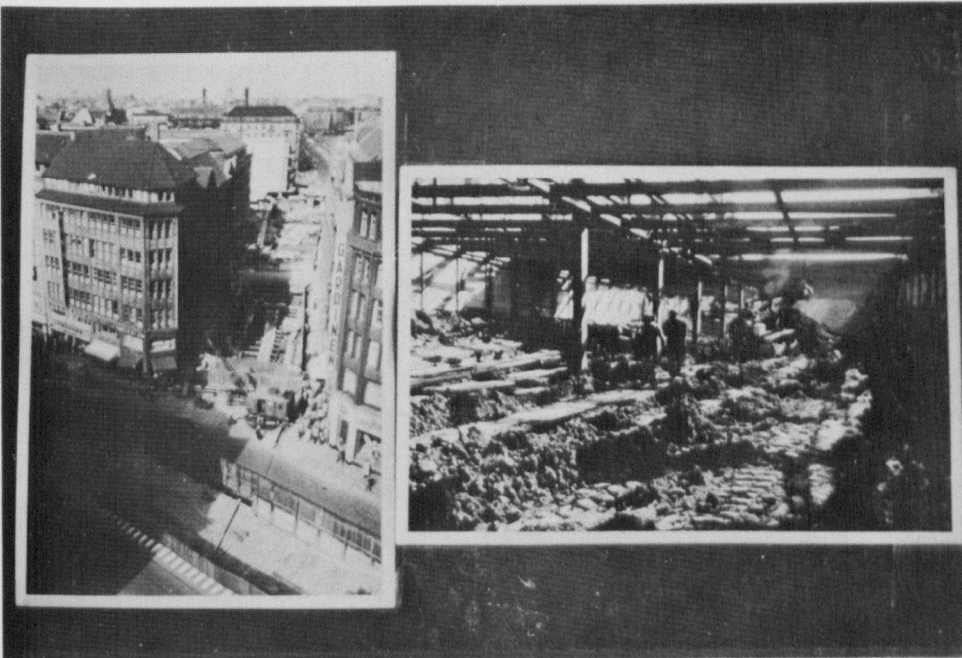

Figure 58. Cut-and-cover tunnel construction method

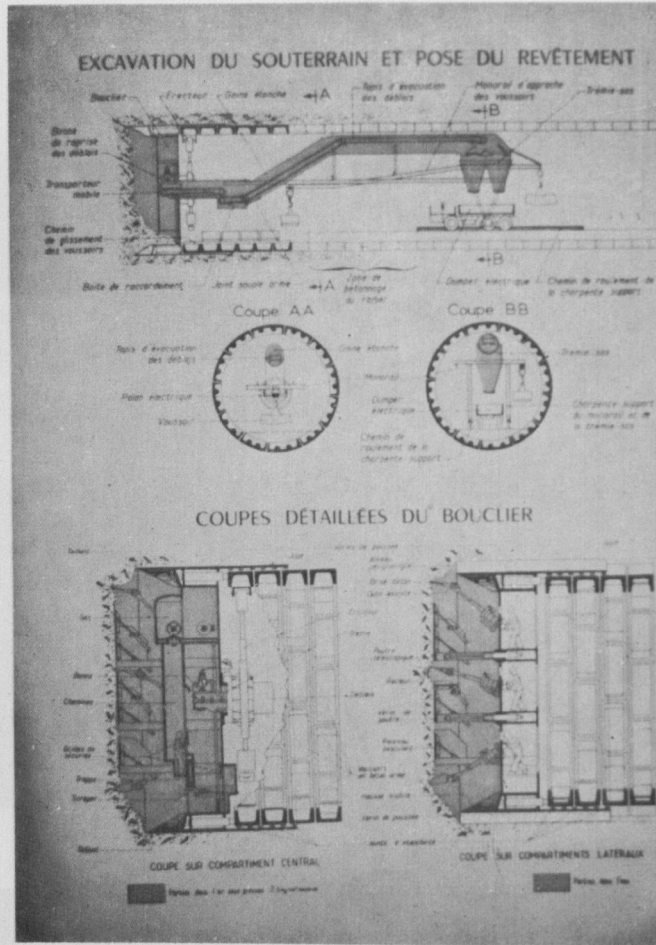

Figure 59. Boring method of tunnel construction

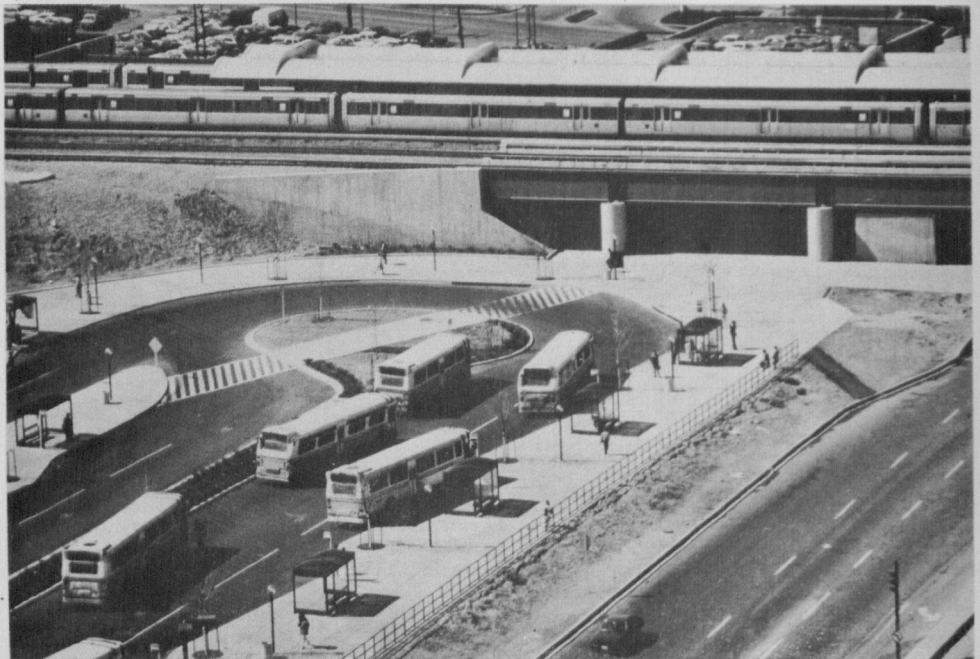

Figure 60. Bus and "Park-and-ride" feeders to rapid transit (Washington)

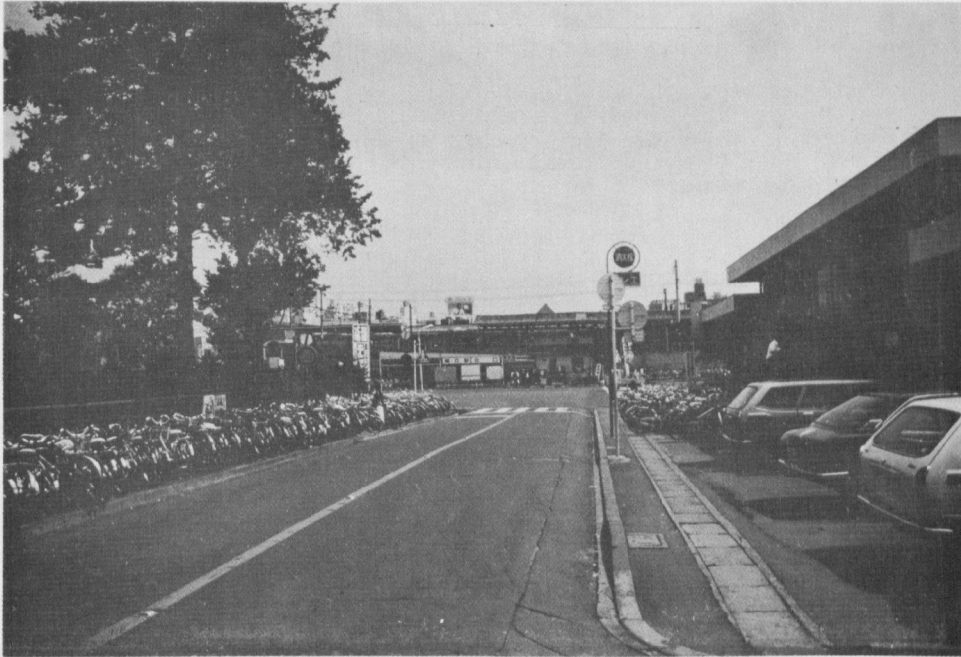

Figure 61. Bicycle parking at a regional rail station in Tokyo



Figure 62. Munich S-Bahn (regional rail)

a tunnel into a diametrical system through the city (63). Extremely well designed and operated, this system is a part of general regional transit. Two platforms, one on each side of the trans, have been built for stations with high service frequency: people enter on one side and exit on the other simultameously.

Some imagination was used in Toronto in providing double-decker regional rail cars. In Paris regional rail (64) has been constructed through the center city for a high-speed regional service with its own downtown distribution and a number of transfer stations with the Metro.

The number of cities building rapid transit has been increasing rapidly, as can be seen in (65): the years from 1950 to 1990 are plotted horizontally, the number of cities opening new rapid transit is plotted vertically. There are today about three times more cities with rapid transit than there were in 1950.

To summarize, in planning high-performance transit (semi-rapid and rapid transit) there are many important aspects to consider. Not only substantial investment and considerable economic benefits, but also important social goals which can be achieved with construction of high-performance transit must be evaluated. We create a system which provides reliability and backup for many situations which may occur, energy problems being only one set of them. What is sometimes overlooked, but is very important, is that planning of these systems is not only physically a large undertaking, but it is also an occasion on which various organizations, professionals and citizens begin to look into their city much more carefully. They think about its future, about potential improvements, about better planning, about better forms for the city; in general, the entire city begins to move much more rapidly; it progresses and becomes much more proud of itself in that process, due to the new rapid transit

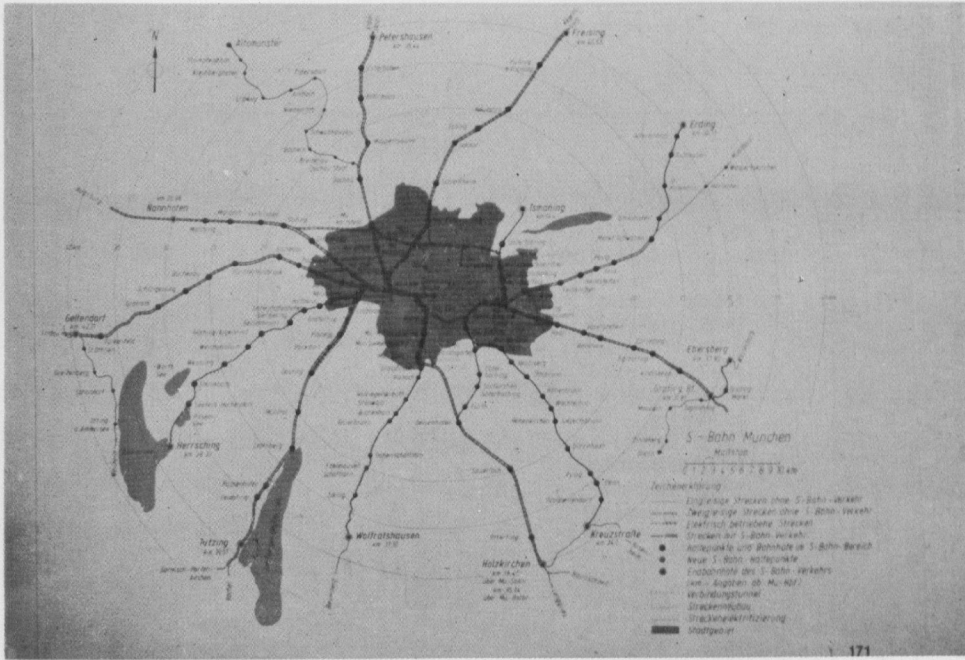

Figure 63. Recently completed Munich S-Bahn network serves the entire region



Figure 64. New RER (regional rail) line in Paris

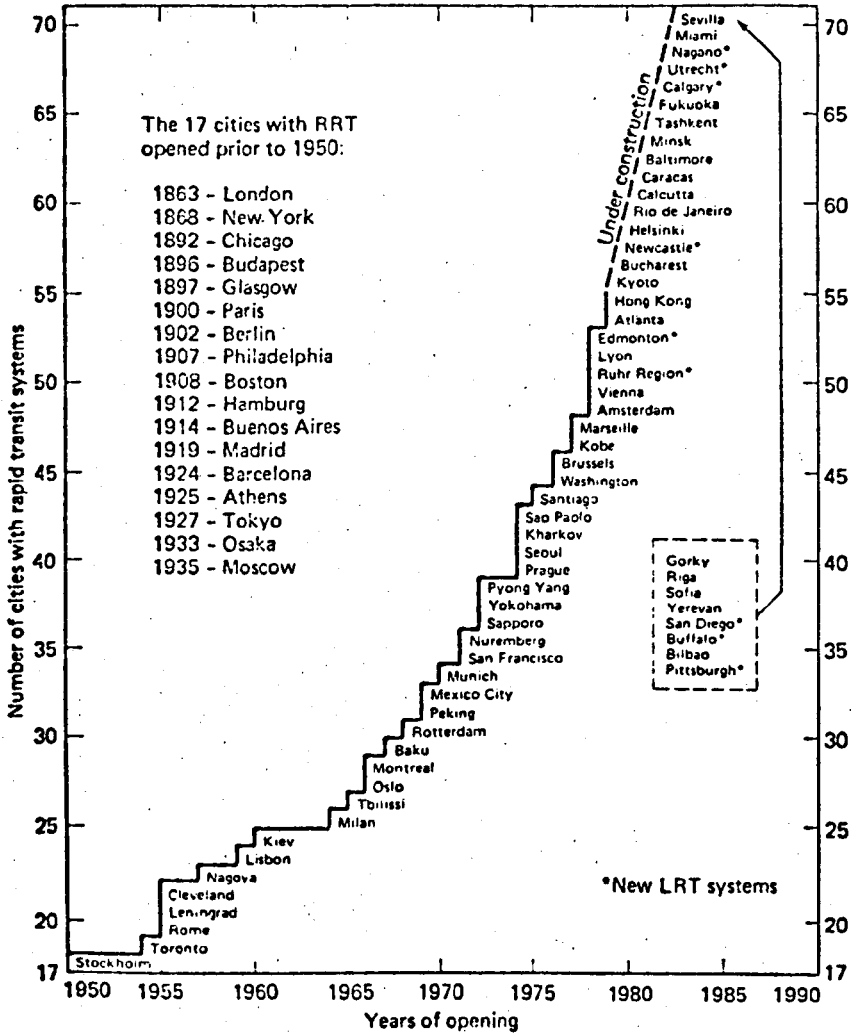

Figure 65. Number of world cities with rapid transit and years of their opening

system and activities related to it. In any city where there is good planning of rapid transit, one can see that the city has also advanced greatly in its awareness of possibilities for improvements, as well as increased pride of itself.

In conclusion, we realize today that we have a family of transit modes, from the private automobile to street transit and high-performance transit (66) which we must use judiciously, each mode where it is best suited. Rapid transit is an important, sometimes the most important, part of that solution. Complementary actions which are being increasingly emphasized, include better traffic engineering, (67, 68) i.e. various measures for management of traffic, so that the automobile can be handled better in our cities. Traffic flow should be improved, while many areas should be reserved exclusively for pedestrians, for people to feel more at home in cities, to enjoy living there. In general, we must create the urban environments which our urbanized society deserves to have (69, 70).

Rapid transit is not a monopoly of western countries any more. It has become a necessity in all countries which have major cities. Actually, it has become a symbol of modern, efficient and attractive cities (71). As we all continue to learn to better combine transportation with urban form and activities, to create functionally successful systems, as well as physically and environmentally attractive cities, the role of different forms of rail transit will further increase in years to come.

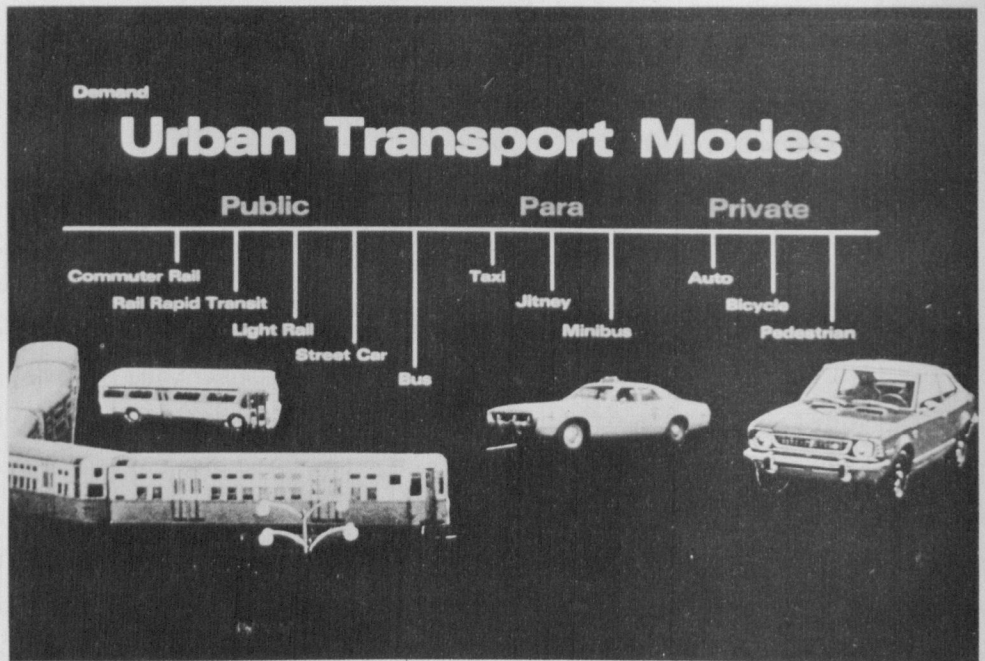

Figure 66. The family of urban transportation modes

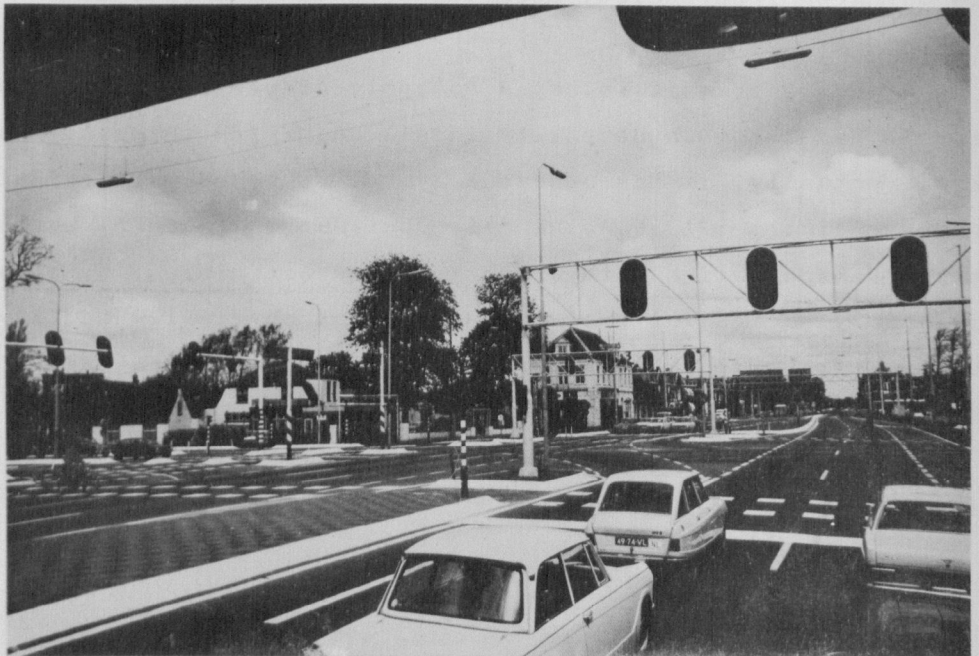

Figure 67. Extensive use of traffic engineering measures
(The Hague, Netherlands)



Figure 68. Pedestrian and bicycle regulation (The Netherlands)



Figure 69. Pedestrian area in a new residential development (Sweden)

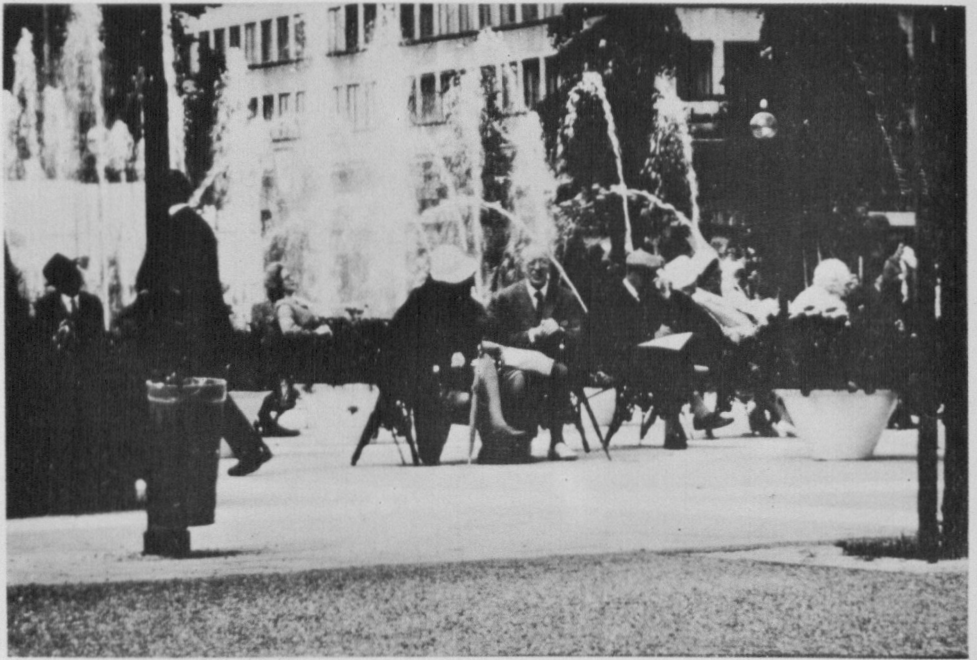

Figure 70. Pedestrian area in center city (Sweden)

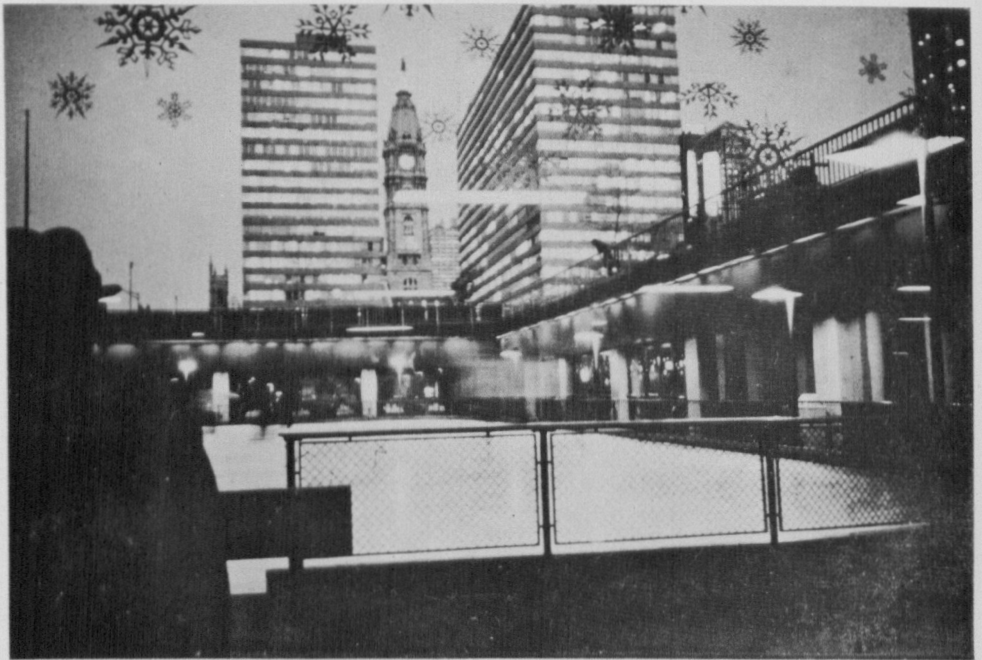

Figure 71. Penn-Center and City Hall in Philadelphia