



4-2010

PHOSGENE-FREE ROUTE TO TOLUENE DIISOCYANATE

Nasri Bou-Saba
University of Pennsylvania

Caryl Dizon
University of Pennsylvania

Devi Kasih
University of Pennsylvania

Bryce Stewart
University of Pennsylvania

Follow this and additional works at: http://repository.upenn.edu/cbe_sdr

 Part of the [Biochemical and Biomolecular Engineering Commons](#)

Bou-Saba, Nasri; Dizon, Caryl; Kasih, Devi; and Stewart, Bryce, "PHOSGENE-FREE ROUTE TO TOLUENE DIISOCYANATE" (2010). *Senior Design Reports (CBE)*. 16.
http://repository.upenn.edu/cbe_sdr/16

This paper is posted at ScholarlyCommons. http://repository.upenn.edu/cbe_sdr/16
For more information, please contact libraryrepository@pobox.upenn.edu.

PHOSGENE-FREE ROUTE TO TOLUENE DIISOCYANATE

Abstract

A Gulf Coast production plant was designed for a phosgene-free route manufacture of 2,4-toluene diisocyanate (TDI) from toluene diamine (TDA). The process was designed to generate 300 million pounds of TDI per year within the required process specifications. Two reactors were to be installed in order to improve the overall yield of TDI, followed by a series of three distillation columns to ensure highly pure market competitive product. Safety concerns, the start-up process, and other potential considerations are also included.

The results of economic analysis for the base case of the project returned a Net Present Value (NPV) of \$20,653,700 with an initial rate of return (IRR) of 18.05% and a return on investment (ROI) of 12.03%. Further analysis on the assumptions made in these calculations may be required before final project approval is granted.

Disciplines

Biochemical and Biomolecular Engineering

PHOSGENE-FREE ROUTE TO TOLUENE DIISOCYANATE

Nasri Bou-Saba (University of Pennsylvania)

Caryl Dizon (University of Pennsylvania)

Devi Kasih (University of Pennsylvania)

Bryce Stewart (University of Pennsylvania)

Senior Design Report

April 13, 2010

University of Pennsylvania

Department of Chemical and Biomolecular Engineering

Faculty Advisor: Prof. Leonard Fabiano, Dr. Daeyeon Lee

Recommmended by: Mr. Bruce Vrana, DuPont Engineering Technology

University of Pennsylvania
School of Engineering and Applied Science
Department of Chemical & Biomolecular Engineering
220 South 33rd Street
Philadelphia, PA 19104

April 13, 2010

Dear Mr. Fabiano, Dr. Lee, and Mr. Vrana,

Enclosed is our proposed process design on “Phosgene-Free Route to Toluene Diisocyanate (TDI)” problem statement provided by Mr. Bruce Vrana of DuPont Engineering Technology. Our focus is to design a high yielding process that is both technologically and economically feasible in producing 99.95% pure TDI from toluene diamine (TDA). The process is made up of two main process blocks – the Reactor System and Separation Process – and achieves the required capacity specified in the problem statement. Included in our consideration is to design an optimal process by recycling reactants, minimizing utility costs, and removing byproducts in an eco-friendly manner.

The following report details the process, equipment needs and estimated costs, approximated power requirements, and a detailed economic analysis. A complete ASPEN Plus flow sheet is also enclosed for your reference. Due to limited data availability, assumptions relevant to the process design are also discussed and various non- and economic sensitivity analyses have also been included.

Finally, we would like to thank Professor Leonard Fabiano, Dr. Daeyeon Lee, Mr. Bruce Vrana, Mr. Steve Tieri, and Mr. Gary Sawyer for the great assistance. Kindly contact the design group if you have any questions regarding any aspect of the report.

Sincerely,

Nasri Bou-Saba

Devi Kasih

Caryl Dizon

Bryce Stewart

Table of Contents

Abstract.....	6
Introduction.....	7
Project Charter.....	12
Innovation Map and Technology Development Summary.....	14
Market and Competitive Analyses.....	18
Preliminary Process Synthesis.....	23
Process Flow Diagrams and Material Balances.....	32
Process Descriptions.....	41
Energy Balance and Utility Requirements.....	50
Process Energy Balance.....	51
Utility Requirements.....	57
Cooling Water.....	57
Steam.....	58
Fuel Oil and Solid Waste.....	59
Electricity.....	59
Unit Descriptions.....	60
Unit Specification Sheets.....	75
Equipment Cost Summary.....	125
Fixed-Capital Investment Summary.....	128
Operating Cost and Economic Analysis.....	132
Economic Assumptions and Project Operations.....	133
Operating Cost Summary.....	134
Variable Costs.....	134
Fixed Costs.....	137
Cash Flow and Profitability Analysis.....	139
Other Economics Uncertainties.....	145
Other Issues and Considerations.....	147
Environmental Concerns.....	148
Plant Safety Concerns.....	149
Plant Start-up.....	152
Conclusion and Recommendations.....	153

Acknowledgements.....	157
List of Figures and Tables.....	159
Bibliography.....	162
Appendix.....	167
Appendix 1.....	168
Appendix 2.....	187
Appendix 3.....	189
Appendix 4.....	191
Appendix 5.....	193
Appendix 6.....	196
Appendix 7.....	216
Appendix 8.....	231
Appendix 9.....	351

Abstract

Abstract

A Gulf Coast production plant was designed for a phosgene-free route manufacture of 2,4-toluene diisocyanate (TDI) from toluene diamine (TDA). The process was designed to generate 300 million pounds of TDI per year within the required process specifications. Two reactors were to be installed in order to improve the overall yield of TDI, followed by a series of three distillation columns to ensure highly pure market competitive product. Safety concerns, the start-up process, and other potential considerations are also included.

The results of economic analysis for the base case of the project returned a Net Present Value (NPV) of \$20,653,700 with an initial rate of return (IRR) of 18.05% and a return on investment (ROI) of 12.03%. Further analysis on the assumptions made in these calculations may be required before final project approval is granted.

Introduction

Introduction

TDI are intermediates in the production of polyurethanes and polycarbonates, which have many useful properties. Polycarbonates are widely used in the manufacture of CD and DVD discs, while polyurethanes are used in the production of foams, elastomers, and hard polymers. With the input of Professor Fabiano, who had ample experience in TDI processes, we were urged to create a process to produce TDI with almost 100% purity.

The following report describes a chemical process for producing virtually 100% pure TDI without introducing the widely used component, phosgene. Phosgene is a colorless volatile liquid or gas that is produced by passing purified carbon monoxide and chlorine gas through a bed of porous activated carbon. It is a valuable industrial reagent and building block in organic synthesis but is also a highly toxic material. Its leaks have caused several casualties in many industrial processes.

Phosgene was formerly used as a chemical weapon during World War I. At room temperature (70°F), phosgene is a poisonous gas. Its gas may appear colorless or as a white to pale yellow cloud and its odor may not be noticed by all people exposed. Although phosgene was never as notorious as mustard gas, it is an insidious poison that has killed far more people. Among the chemicals used in World War I, phosgene was responsible for the large majority of deaths, about 85% of the 100,000 deaths caused by chemical weapons. Its symptoms may be

slow to be recognized, as phosgene can only be detected at 0.4 ppm, which is four times its safety Threshold Limit Value.¹

Phosgene reacts violently and decomposes to toxic compounds on contact with moisture, including chlorine, carbon monoxide and carbon tetrachloride. People may be exposed to phosgene through skin or eye contact, touching or drinking water, breathing air, and eating contaminated food. Inhalation can cause fatal respiratory damage as phosgene reacts heavily with HCl that is released in its reaction with water in the lungs. It can also cause damage to the skin, eyes, nose, throat, and lungs. Today, gaseous phosgene has increasingly been supplanted by more easily handled reagents. This is why it was extremely important to remove Phosgene as a reactant in our TDI production process.¹

We were charged with creating an economically feasible and environmentally friendly process design for producing 300 million pounds of TDI per year in high yield from toluene diamine (TDA). It was our goal to create a design that recycled the majority of unreacted starting materials as well as disposed any waste material in an economical and eco-friendly manner. We were also to minimize the plant's utility requirements in an effort to increase its sustainability.

The phosgene-free pathway of producing TDI by reacting TDA, oxygen, and carbon monoxide in the solvent, 2,2,2-trifluoroethanol (TFE), was introduced to us as an attractive alternative to the common methods of producing TDI.

¹ *Hazards: Phosgene*. Centers for Disease Control and Prevention, Sept. 2005. Web. 28 Jan. 2010.

The overall reaction is:

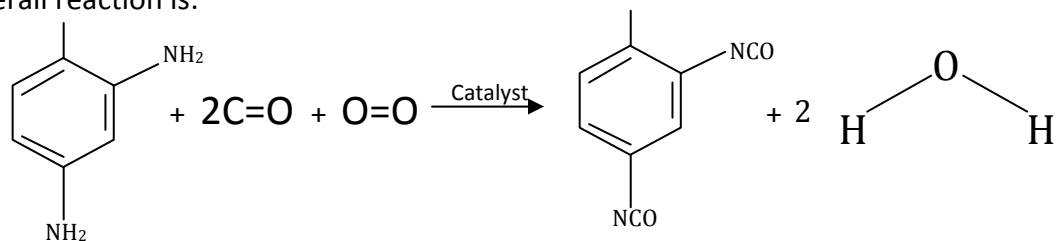

A representation of this mechanism is presented below:

(1)

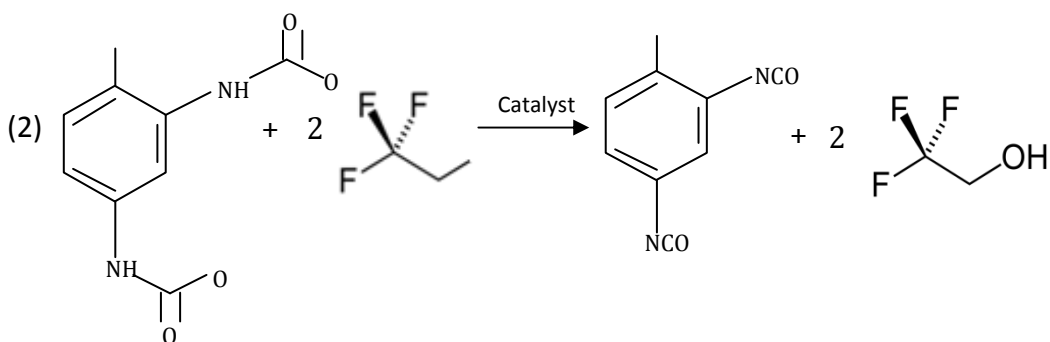
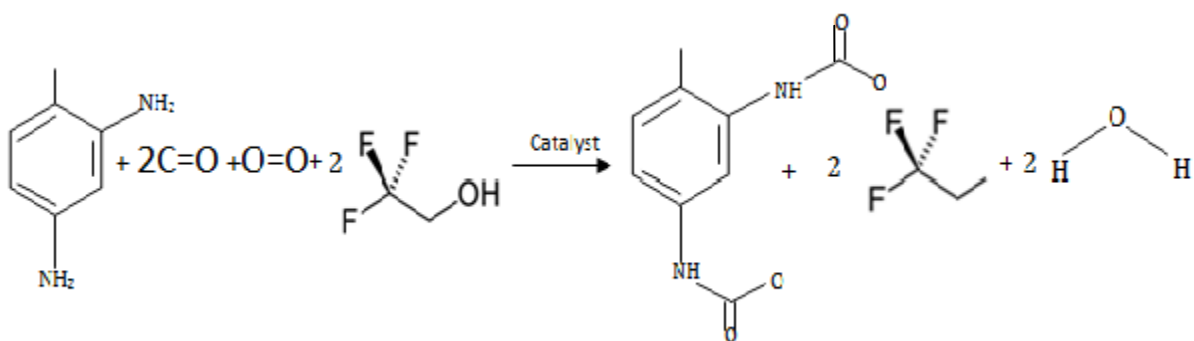

With further research we concluded that our process most likely includes a two-step mechanism. In the first step, TDA reacts with carbon monoxide, oxygen, and the solvent, TFE, to produce the intermediate toluene dicarbamate. In the second step, the dicarbamate is

degraded to create the TDI product and the water byproduct. The TFE solvent is regenerated in this step as well. It is important to note that the entire reaction mechanism is carried out in the presence of N,N'-(bis(3,5-di-tert-butyl-salicylidene)ethylenediamino)cobalt (II) [Co- tBu- Salen] catalyst.²

² Hassan, Abbas, Ebrahim Bagherzadeh, Rayford G. Anthony, Gregory Borsinger, and Aziz Hassan. SYSTEM AND PROCESS FOR PRODUCTION OF TOLUENE DIISOCYANATE

Project Charter

Project Name	Phosgene-Free Route to Toluene Diisocyanate
Project Champions	Nasri Bou-Saba, Caryl Dizon, Devi Kasih, and Bryce Stewart
Project Leaders	Bruce Vrana, Dr. Daeyon Lee, and Mr. Leonard Fabiano
Specific Goals	To produce high purity TDI from TDA in high yield using an environmentally –friendly phosgene-free process
Project Scope	<ul style="list-style-type: none"> • Included: <ul style="list-style-type: none"> ○ Production of 300 million pounds of highly pure TDI from TDA without using Phosgene ○ Creation of an environmentally friendly process with high amounts of recycle and minimized use of utilities ○ Maintaining an economically feasible process with an acceptable profit margin • Excluded: <ul style="list-style-type: none"> ○ Separation of the 2,4 TDI from 2,6 TDI (80% and 20% composition respectively)
Deliverables	<ul style="list-style-type: none"> • Process Efficiency Analysis <ul style="list-style-type: none"> ○ Product Purity ○ Product Yield ○ Utility Usage ○ Safety Data • Economic Data to Management <ul style="list-style-type: none"> ○ Cost Analysis ○ Profits ○ ROI
Project Timeline	To produce market-ready TDI in 12 months

Project Charter

Innovation Map and Technology Development Summary

Innovation Map

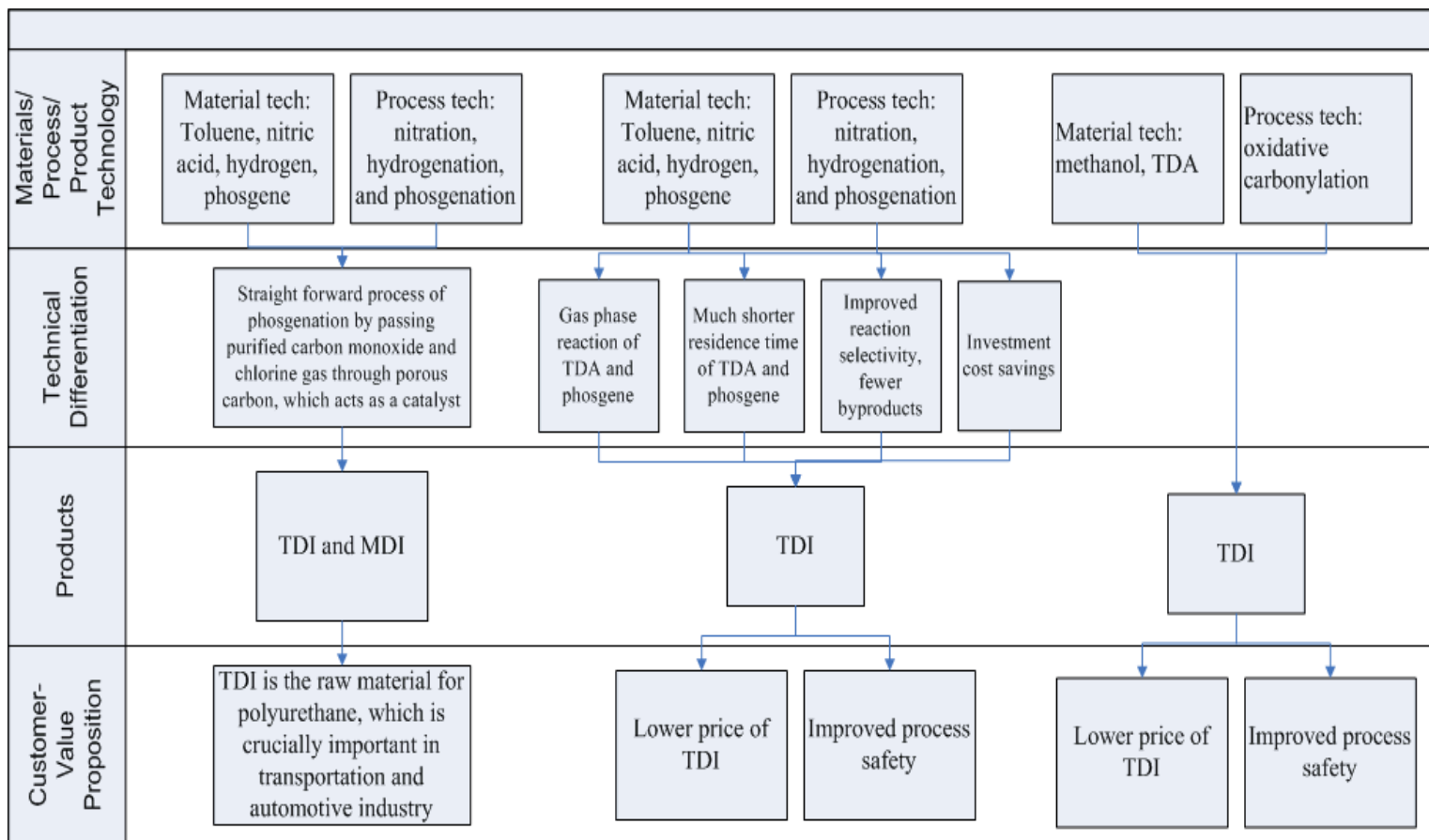

Figure 1: Innovation map of commercial TDI production

Technology Development Summary

The traditional route for the manufacture of TDI starts with the nitration of toluene using nitric acid to produce dinitrotoluene followed by catalytic hydrogenation to toluene diamine. The toluene diamine is dissolved in an inert solvent and reacted with phosgene to produce a crude TDI solution. Phosgene is made on-site in a simple, single step process by passing purified carbon monoxide and chlorine gas through a bed of highly porous carbon, which acts as a catalyst. The subsequent separation and purification of the products of reaction from the polymeric byproducts that are formed is a multi-step process. The hydrogen chloride that is produced as a byproduct of the reaction is recovered and sold either directly or in the form of hydrochloric acid (HCl). On the flip side, HCl, which is produced in stoichiometric amount as a by-product, causes corrosion, and thus a stoichiometric amount of NaOH is required to neutralize the HCl. (Serrano Fernandez *et al*, 2008)³

Even though this technology has been the basis of commercial isocyanate production for many years, numerous attempts have been made to develop even lower cost, non phosgenation processes to produce isocyanates. Furthermore, as restrictions upon the use of very toxic materials such as phosgene within the chemical industry have become more rigorously enforced, there has been increasing interest in developing alternative methods to phosgene in the synthesis of isocyanate.

Bayer has developed a gas-phase phosgenation (GPP) process for the production of TDI from TDA. The main difference from conventional TDI processes is in the use of gas-phase

³ Serrano Fernandez, Francisco Luis, Beatriz Almena Munoz, Ana Padilla Polo, Arana Orejon Alvarez, Carmen Claver Cabrero, Sergio Castillon Miranda, Pilar Salagre Carnero, and Ali Aghmiz. One-step Catalytic Process for the Synthesis of Isocyanates. REPSOL-YPF,S.A., assignee. Patent 7423171. 9 Sept. 2008.

reaction of TDA and phosgene, as opposed to these reactants being handled as dilute solutions in a solvent such as *ortho*-dichlorobenzene. The gas-phase phosgenation technology results in significant savings on solvents, leading to operating cost savings due to a reduction in energy consumption required to process the much smaller volume of solvent during distillative recovery. The much shorter residence time of TDA and phosgene in the reactor reduces the required phosgene process inventory considerably. Further benefits are significantly greater reactor throughput per unit time (space-time yield) and the ability to downsize key plant components. These size reductions, lead to additional investment cost savings. The gas-phase technology also provides improved reaction selectivity, generating fewer byproducts. This route avoids the use of phosgene and waste recovery problems associated with HCl. Process safety is vastly improved by the reduction in both phosgene and solvent inventories within the process. A further safety enhancement is the ability to start up and shut down the gas-phase process quickly.

The most recent attempt is the EniChem Urethane Pyrolysis (Non-Phosgene) Process: Here, oxidative carbonylation of methanol is used to produce dimethyl carbonate (DMC). DMC is then reacted with TDA to give a urethane intermediate which is then cracked at high temperature and low pressure to give TDI. (Nexant, 2008)⁴

Existing processes and production facilities for producing the TDI mixture, in particular, are subject to various constraints such as mass flow limitations, product yield, plant size and energy consumption. Accordingly, there is continuing interest in improving the way that TDI is produced.

⁴ *Developments in Toluene Diisocyanate (TDI) Process Technology*. Rep. Nexant, Inc., Oct. 2008

Market and Competitive Analyses

Market and Competitive Analyses

TDI is often marketed as 80/20 and 65/35 mixtures of the 2,4 and 2,6 isomers respectively. As one of the highly produced diisocyanates, TDI accounts for 34.1% of the global isocyanate market in 2000 (ICIS, 2010)⁵. The main outlet for TDI is in the manufacture of polyurethane (PU) flexible foams used in furniture, bedding, and automotive and airline seats. This is achieved by the reaction of TDI with a polyol to produce the foam. Meanwhile, polycarbonates are particularly valued for their optical clarity and impact resistance, and are used in CD and DVD discs among many other applications.

Globally, flexible PU foams constitute by far the largest market for TDI, 88% of the global demand (30% for transportation, 20% for furniture, 14% for carpet underlay, 11% bedding, 5% packaging, and 8% for other foam uses). Rigid urethane foams come next, contributing to 4% of the demand, followed by PU adhesives and sealants with 3%, PU coatings and PU elastomers for another 3% and 2% respectively (ICIS, 2010).⁵

Polyurethane coatings are one of the fastest growing sectors of the paints and coatings industry. Despite their relatively high cost, they are suitable for a range of high performance applications due to their excellent durability, resistance to corrosion and abrasion, and flexibility. Markets for PU coatings include automotive refinishing, wood finishes and high performance anti-corrosion coatings. On the other hand, PU elastomers are noted for their toughness, flexibility, strength, abrasion resistance, shock absorbency and chemical resistance.

⁵ "Toluene Di-isocyanate (TDI) CAS No: 584-84-9." *ICIS.com*.

Because they are relatively expensive compared to most other elastomers, they are used in more demanding applications such as automobile bumper covers and facias, industrial rollers, sport soles and boots, and mechanical goods.

Today, the number of global TDI enterprises is over 30 with more than 40 sets of TDI production lines, the total production capacity is 2.1 million tons per year and mainly located in Asia, Europe and the United States. With most of TDI's output going into the furniture and automotive sectors, demand is sensitive to economic activity. With the economic downturn, flexible PU foams demand has fallen in 2009 by between 5% and 20% in the US and western Europe, according to US-based consultants SRI. In stronger economies, the fall has been more limited up to 5%. However, SRI expects demand for flexible foams will return to grow at 2.4% per year through 2011 and 2-4% per year up to 2013.

Currently, there are five major producers of TDI serving the global demand, namely BASF, Bayer, Lyondell, Mitsui Chemicals, and Dow Chemicals. The current US TDI production levels expressed in terms of capacity data for several producers are tabulated below.

Company	Capacity (MM lbs per year)
BASF	350
Bayer	400
Dow	220
Total	970

Figure 2: Major producers' TDI production capacity⁵

The demand for TDI is still on the increase today. Regionally, Asia contributes to the fastest growth at around 8% per year. This is mainly due to a boom in China's automobile and construction sectors, which accounts for three-quarters of TDI consumption. Automotive sales

in China passed the 10 million vehicles per year level in 2009 with sales up by 38% in 2009 compared to the previous year, according to the China Association of Automobile Manufacturers. Moreover, various producers in China are also expanding their capacity. Bayer MaterialScience is constructing a 250,000 metric tons TDI plant in Shanghai, while Gansu Yinguang Chemical Industry Group Co., Ltd. and Hebei Cangzhou Dahua Co., Ltd. also have expansion plans that are scheduled to come on stream in 2010. If these projects can be completed on schedule, the demand for TDI in China is expected to be around 700,000 tons in 2010.⁶

Growth in the US itself is much lower than the world average and has been adversely impacted by the slowdown in the economy. Flexible PU foams account for 88% of TDI demand in the US with transportation, furniture, carpet and bedding markets being the main outlets. The ailing US transportation industry accounts for nearly 22% of total PU consumption, according to the American Chemistry Council. The demand, imports, and exports graph for TDI in the US is provided in the graph below:

⁶ *Analysis and Forecast of China TDI Market 2009-2010. ReportLinker. Web. 15 Mar. 2010.*

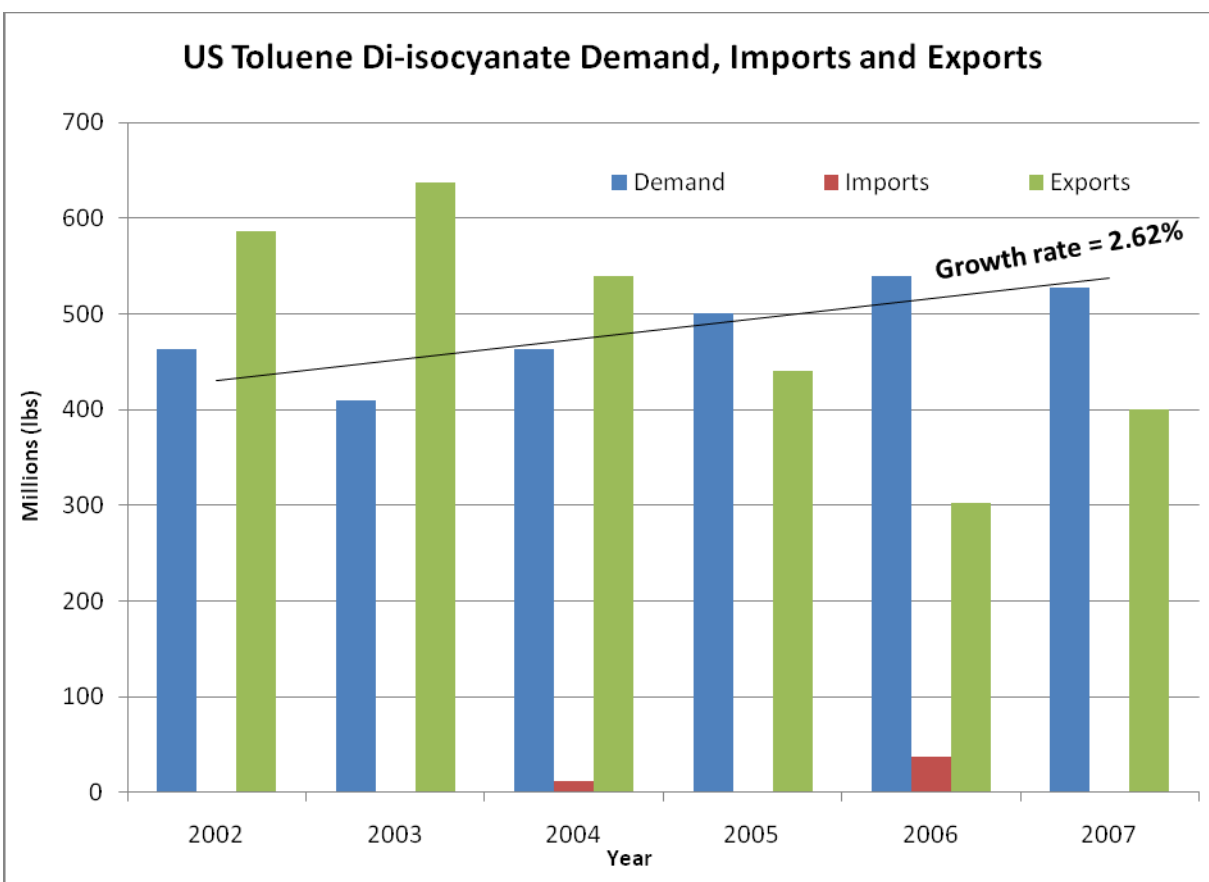

Figure 3: TDI demand in USA shows a moderate increasing trend above⁷

Even with the overall recent decreasing demand trend, the TDI installed capacity is barely sufficient to meet current US domestic demand and export volumes. Near-term demand increases will have to be addressed by an increase in imported material or decreasing the amount exported. As there is no apparent relief in sight for energy and feedstock cost pressure, pricing will likely remain at the current historical high level of US\$1.90-1.96 per pound, according to ICIS. Thus, pricing the TDI to US\$1.50 per pound as in our project will look very promising, especially supported by the accelerated growth in automotive and transportation industries.

⁷ *Developments in Toluene Diisocyanate (TDI) Process Technology*. Rep. Nexant, Inc., Oct. 2008

Preliminary Process Synthesis

Preliminary process synthesis

Raw materials and product specifications

The phosgene-free route manufacture of 300 million pounds of TDI per year is a novel process such that information regarding the kinetics, the effectiveness and the role of various types of catalyst, solvent, and promoter are very limited. Therefore, the TDI synthesis is largely based on the US patent invented by Fernandez *et al*, 2007. For this process, a reactant feed consisting of TDA, oxygen and carbon monoxide is passed over a fixed bed of Schiff Base-Type Ligand Catalyst, Co-tBu-Salen. An organic solvent, 2,2,2-trifluoroethanol (TFE) and a promoter, sodium iodide (NaI), are also charged throughout the reaction process to ensure the TDI overall yield of 64% is achieved, as specified in the patent.

The amount required for each of the raw materials and the process enhancers are derived from the laboratory-scale ratio with several amendments for optimization modeled by Aspen. The required ratios of the raw materials are tabulated below.

Table 1: The required ratio of raw materials per pound of TDI produced.

Raw Material:	Unit:	Required Ratio:	
Toluene diamine	lb	0.73	lb per lb of Toluene Diisocyanate
Carbon monoxide	lb	3.07	lb per lb of Toluene Diisocyanate
Oxygen	lb	0.18	lb per lb of Toluene Diisocyanate

The required amount of TFE and NaI are fixed for the entire process since they are not consumed. As modeled by ASPEN, the respective amount of TFE and NaI needed are 1,115,835 pounds and 2,730 pounds for a total of 314 million pounds of TDI per year. The 5% excess of TDI

production works as a buffer considering possible polymeric formation throughout the synthesis. In addition, the ratio of the carbon monoxide to oxygen in the vapor phase is controlled to 49:1 to avoid explosion risk.

To improve the overall yield of TDI production and in turn reduce the production cost, two major reactor system options are proposed.

Option 1:

A single 3-loop pass reactor is assembled to improve the overall TDI production yield from 64% (Fernandez, *et al*) to 97.2% (Aspen). The improved yield is expected to be maintained as the operation reaches steady-state. The process flow sheet for this scenario is presented in

Figure 4.

Option 2:

Two reactors are assembled such that the vapor product of the first reactor is mixed with the recycle stream coming from the separation system. The focus is to use up as much TDA and any intermediate products obtained from the first reactor. This process is presented in

Figure 5.

Figure 4: Option 1 -- Single three-loop pass reactor detailed process flow sheet

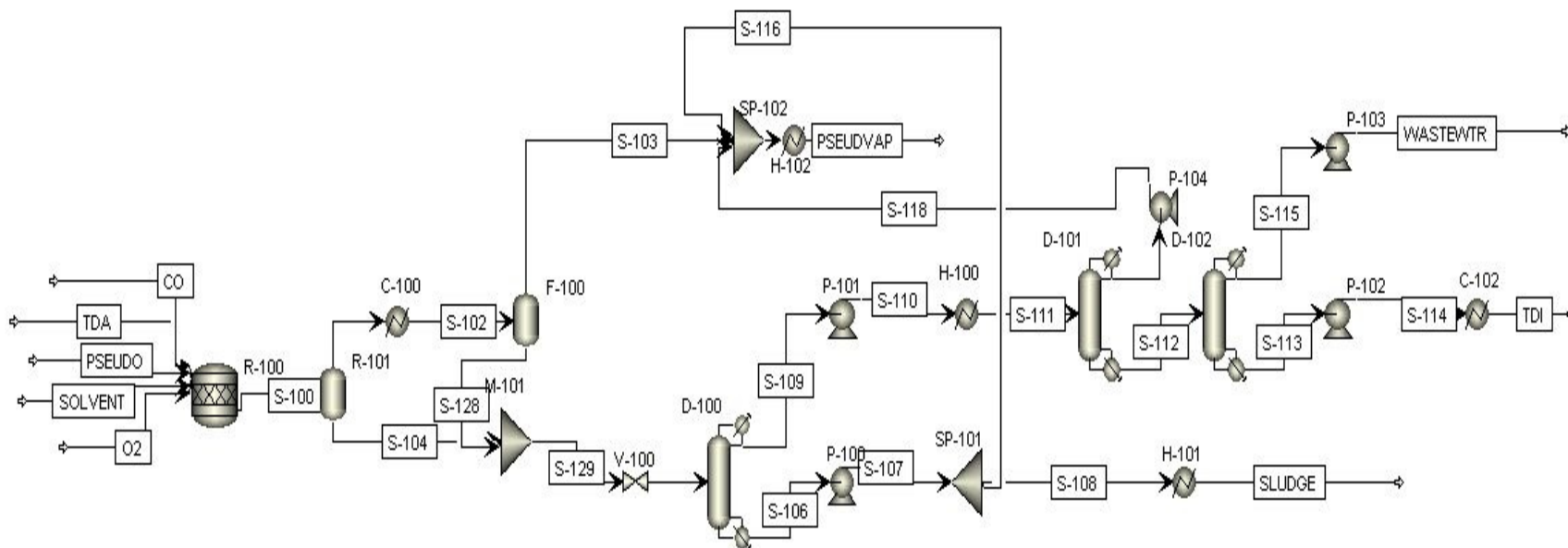

The choice of the reactor system is made based on two main considerations:

1. Possible cost savings of TFE

Based on the discussion with Shaun Julian, an Account Manager in oils, greases, waxes and chemicals department at Halocarbon Products Corporation, it is found that the required amount of TFE in this project accounts for approximately 25% of the current TFE global demand of 5 million pounds. In addition, the current cost of TFE is approximately \$12 per kilogram or \$5.45 per pound. Thus, the TDI manufacture is enormously sensitive to TFE requirement.

Comparing the amount of TFE of which the two options will consume using the ASPEN flow sheet, *option 1* will save 22,000 millions of TFE, which is equivalent to \$120,008.

2. Reactor size

The reactor system in *option 1* is a considerably more complex assembly than that in *option 2* which only consists of two individual packed-bed reactors. The following is the figure of reactor system configuration in *option 1*.

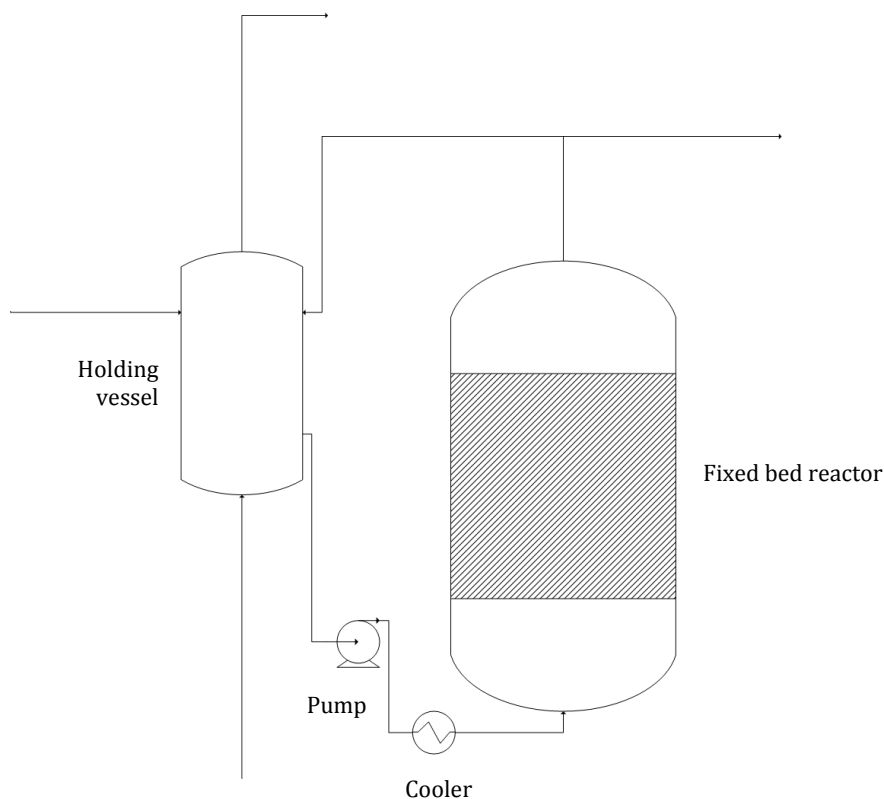

Figure 6: Three-loop pass reactor system

As shown in **Figure 6** the reactor system in *option 1* consists of a holding vessel, a packed bed reactor, a cooler, and a pump. In addition, there is a big trade-off in lowering the reactor's residence time since the volume required is inversely related. Size optimization by changing the volumetric flow rate passing through the reactor also involves a large uncertainty in the effectiveness of the actual reactions take place. This is due to the unavailability of the reaction kinetics data. Furthermore, the net work required by the pump will be considerably increased and thus increasing the electricity consumption.

Assuming a base case of per pass residence time of 20 minutes of half-full reactor⁸, a 3-loop pass reactor will cost \$55,109,461, with a vessel diameter and length of 135 ft and 67 ft respectively. On the other hand, the reactor system in *option 2* costs \$19,041,059.23 with the second reactor only one-third of the size of the first reactor. Finally, there is no internal utility requirement involved. Appendix 1H contains the detailed calculations on the reactor costing.

The summary of the incremental possible saving of *option 2* is tabulated.

Table 2: Summary of incremental cost saving of reactor system in option 2

	TFE saving	Reactor price saving	Utility requirement	Total saving
<i>Option 2</i>	(\$120,008.15)	\$36,068,401.73	None	\$35,948,393.58

Considering the profitability of the two potential designs described, *option 2* is significantly beneficial from business perspective. Furthermore, installing two smaller reactors are more feasible than building one considerably bigger reactor.

Separation process and heat integration

Following the production of TDI, it is crucial to isolate the product as pure as possible to be accepted in the market. The competitive minimum purity requirement in the market is 99.5%. (ICIS) To achieve successful separation, 3 distillation columns are proposed. The separation trains with the details of isolated components are presented in **Figure 7**.

⁸ The US patent “One-Step Catalytic Process for the Synthesis of Isocyanates” describes a reaction time ranges from 3 minutes to 3 hours. Due to the lack of relevant reaction kinetics data, the reaction time base case assumption is one hour.

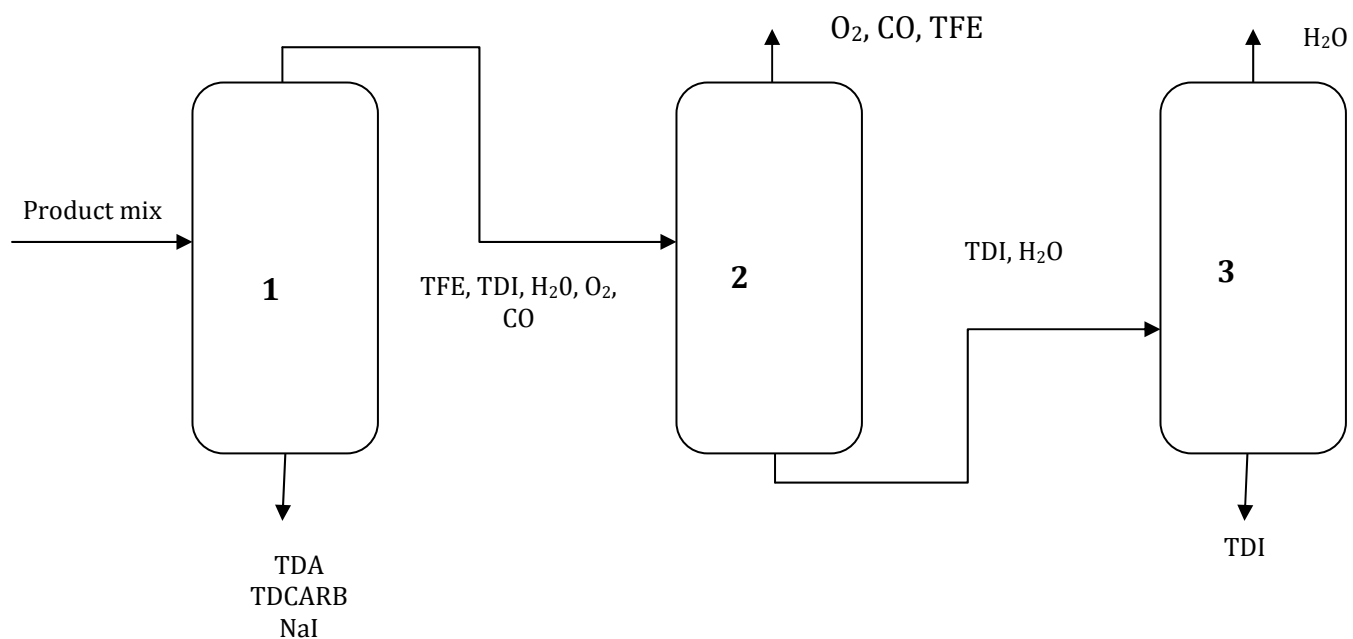

Figure 7: Distillation separation complex

Finally, to minimize the utility requirement and cost, and thus increase profitability, heat integration process would also be conducted thoroughly.

Process Flow Diagram and Material Balances

Process Block Diagrams:

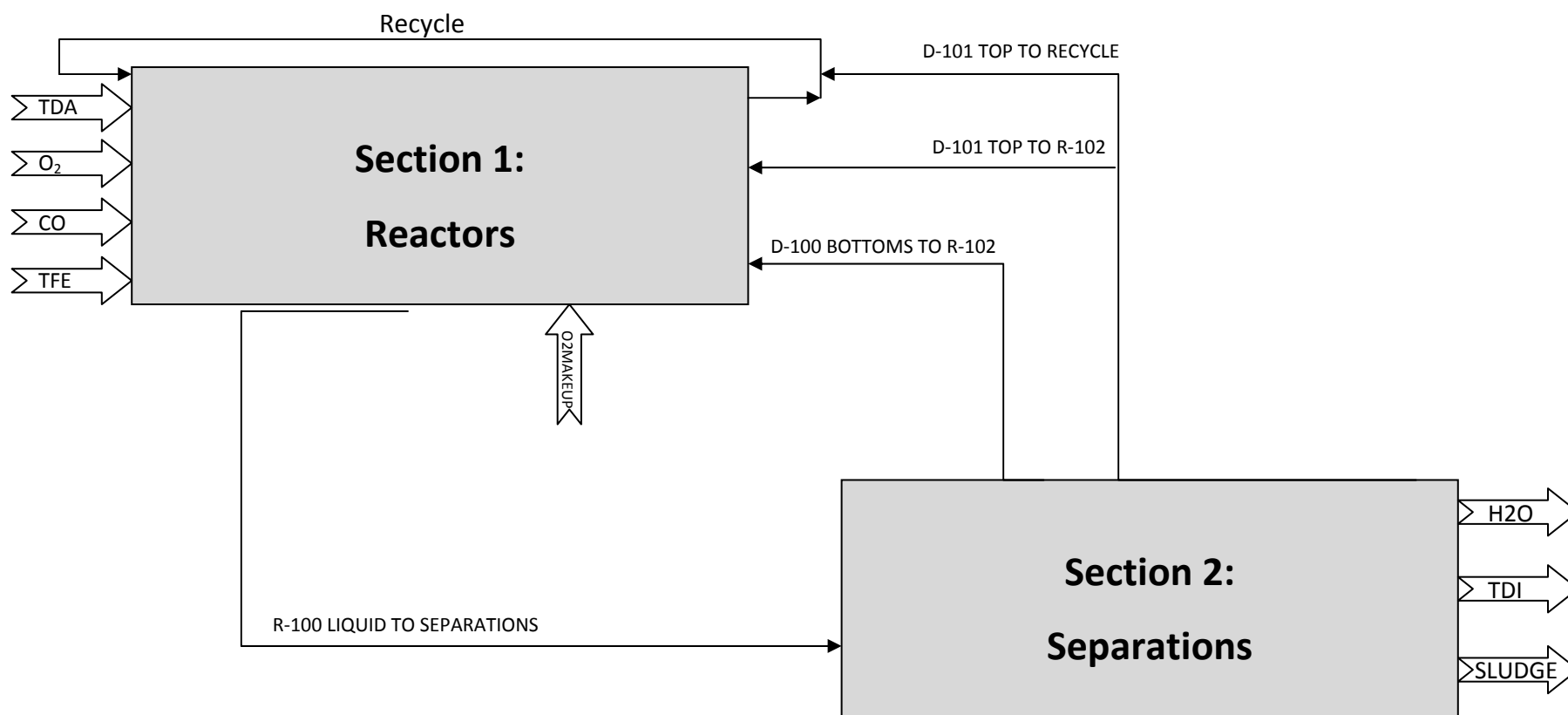

Figure 8: Process Block Diagram

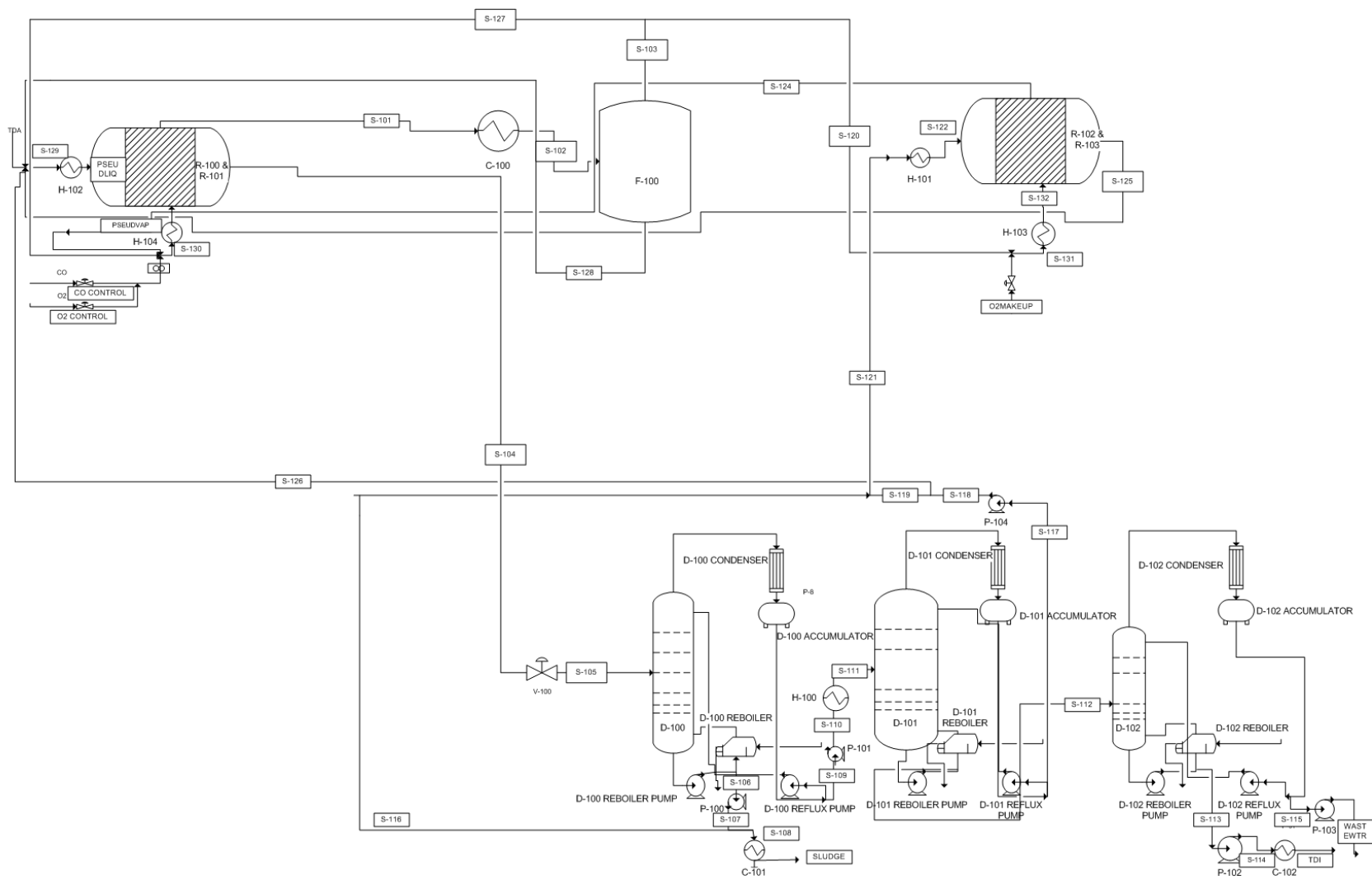

Figure 9: Process Flow Diagram

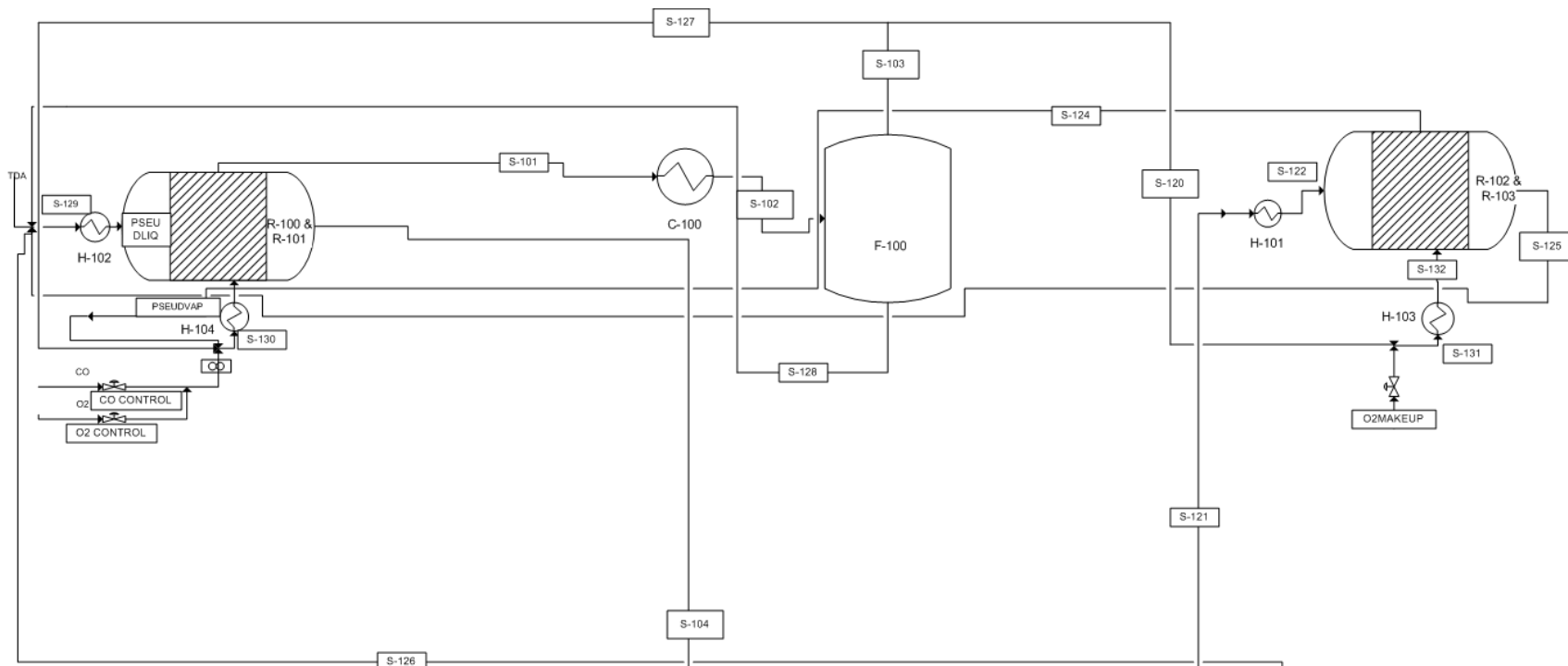

Figure 10: Reactor-system section

Table 3: Stream information for the Reactors Block

	CO	O2	SOLVENT	TDA	O2MAKEUP	PSEUDLIQ	PSEUDO	PSEUDVAP	S-100	S-101	S-102	S-103	S-104
Temperature F	248.00	248.00	248.00	248.00	248.00	248.00	248.00	248.00	282.76	282.76	100.00	99.91	282.76
Pressure psia	652.67	652.67	652.67	652.67	653.00	639.67	652.67	639.67	652.67	652.67	647.67	644.67	652.67
Vapor Frac	1.00	1.00	0.00	0.00	1.00	0.08	0.31	1.00	0.35	1.00	0.52	1.00	0.00
Mole Flow lbmol/hr	456.91	191.45	0.95	228.88	37.00	11964.12	15267.13	3303.01	15901.80	5622.44	5622.44	2951.70	10279.36
Mass Flow lb/hr	12798.09	6126.27	95.34	27962.73	1183.96	1124680.62	1247481.61	122800.50	1294464.04	292971.02	292971.02	84460.84	1001493.02
Mass Flow lb/hr													
TDA	0.00	0.00	0.00	27962.73	0.00	927.29	927.51	0.18	5200.24	1.17	1.17	0.00	5199.07
O2	0.00	6126.27	0.00	0.00	1183.96	450.12	1202.10	752.06	1123.47	993.54	993.54	672.30	129.93
CO	12798.09	0.00	0.00	0.00	0.00	29069.07	109097.65	80028.69	111032.73	103246.65	103246.65	81428.69	7786.08
TDI	0.00	0.00	0.00	0.00	0.00	10279.58	10287.57	7.49	39738.99	34.13	34.13	0.00	39704.85
WATER	0.00	0.00	0.00	0.00	0.00	1608.79	1661.71	52.92	8648.41	417.05	417.05	0.23	8231.36
TDCARB	0.00	0.00	0.00	0.00	0.00	8567.39	8567.47	0.00	17850.01	0.01	0.01	0.00	17850.01
SOLVENT	0.00	0.00	95.34	0.00	0.00	1073778.38	1115737.60	41959.16	1110870.19	188278.47	188278.47	2359.62	922591.72

Table 3 (continued): Stream information for the Reactors Block

	S-120	S-122	S-123	S-124	S-125	S-126	S-127	S-128	S-129	S-130	S-131	S-132
Temperature F	99.91	248.00	279.50	279.50	279.50	36.51	99.91	99.91	118.70	208.66	105.74	248.00
Pressure psia	644.67	648.00	652.67	652.67	652.67	653.00	644.67	644.67	644.67	644.67	644.67	639.67
Vapor Frac	1.00	0.00	0.34	1.00	0.00	0.00	1.00	0.00	0.00	0.99	1.00	1.00
Mole Flow lbmol/hr	885.51	2750.53	3687.15	1236.83	2450.33	6843.05	2066.19	2670.74	11964.12	3303.01	922.51	922.51
Mass Flow lb/hr	25338.25	283360.47	309882.68	63677.91	246204.77	669965.68	59122.59	208510.18	1124680.62	122800.50	26522.21	26522.21
Mass Flow lb/hr												
TDA	0.00	5146.06	926.29	0.18	926.11	0.00	0.00	1.17	927.29	0.18	0.00	0.00
O2	201.69	36.38	316.78	281.45	35.33	93.55	470.61	321.23	450.12	752.06	1385.65	1385.65
CO	24428.61	2180.10	24673.74	23028.61	1645.13	5605.98	57000.08	21817.96	29069.07	80028.69	24428.61	24428.61
TDI	0.00	0.70	10252.94	7.49	10245.45	0.00	0.00	34.13	10279.58	7.49	0.00	0.00
WATER	0.07	0.05	1244.62	52.76	1191.86	0.12	0.16	416.82	1608.79	52.92	0.07	0.07
TDCARB	0.00	17671.51	8567.39	0.00	8567.39	0.00	0.00	0.01	8567.39	0.00	0.00	0.00
SOLVENT	707.88	258325.68	263900.92	40307.42	223593.50	664266.03	1651.73	185918.85	1073778.38	41959.16	707.88	707.88

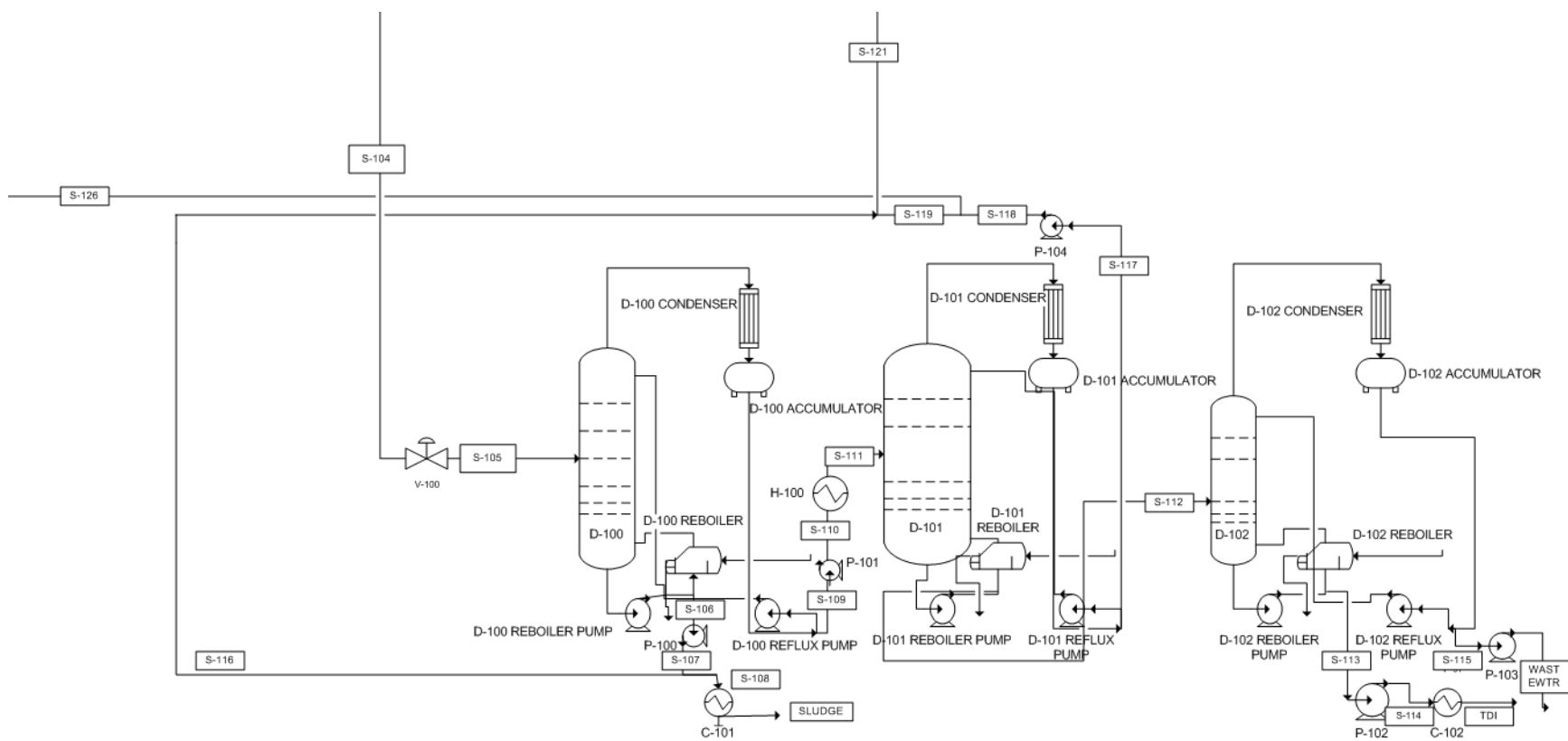

Figure 11: Section 2 - Separation Process

	S-105	S-106	S-107	S-108	S-109	S-110	S-111	S-112	S-113	S-114	S-115	S-116	S-117
Temperature F	96.78	517.84	521.11	521.11	34.98	35.02	120.00	200.71	352.20	352.25	101.70	521.11	34.09
Pressure psia	5.00	4.90	653.00	653.00	2.00	12.00	7.00	7.80	2.01	7.01	1.00	653.00	5.00
Vapor Frac	0.52	0.00	0.00	0.00	0.00	0.00	0.89	0.00	0.00	0.00	0.00	0.00	0.00
Mole Flow lbmol/hr	10279.36	90.25	90.25	0.90	10189.12	10189.12	10189.12	684.89	227.98	227.98	456.91	89.35	9504.23
Mass Flow lb/hr	1001493.02	23048.75	23048.75	230.49	978444.27	978444.27	978444.27	47936.39	39662.81	39662.81	8273.58	22818.26	930507.88
Mass Flow lb/hr													
TDA	5199.07	5198.04	5198.04	51.98	1.03	1.03	1.03	1.03	1.03	1.03	0.00	5146.06	0.00
O2	129.93	0.00	0.00	0.00	129.93	129.93	129.93	0.00	0.00	0.00	0.00	0.00	129.93
CO	7786.08	0.00	0.00	0.00	7786.08	7786.08	7786.08	0.00	0.00	0.00	0.00	0.00	7786.08
TDI	39704.85	0.70	0.70	0.01	39704.15	39704.15	39704.15	39704.15	39656.97	39656.97	47.18	0.70	0.00
WATER	8231.36	0.00	0.00	0.00	8231.36	8231.36	8231.36	8231.20	4.81	4.81	8226.39	0.00	0.16
TDCARB	17850.01	17850.01	17850.01	178.50	0.00	0.00	0.00	0.00	0.00	0.00	0.00	17671.51	0.00
SOLVENT	922591.72	0.00	0.00	0.00	922591.72	922591.72	922591.72	0.01	0.00	0.00	0.01	0.00	922591.71

Table 4: Stream information for the Separations Block

Separations Block

Table 4(continued): Stream information for the Separations Block

	S-118	S-119	S-121	SLUDGE	TDI	WASTEWTR
--	-------	-------	-------	--------	-----	----------

Phosgene-Free Route to Toluene Diisocyanate

Bou-Saba, Dizon, Kasih, Stewart

Temperature F	36.51	36.51	74.96	140.00	140.00	101.75
Pressure psia	653.00	653.00	653.00	648.00	2.01	6.00
Vapor Frac	0.00	0.00	0.00	0.00	0.00	0.00
Mole Flow lbmol/hr	9504.23	2661.18	2750.53	0.90	227.98	456.91
Mass Flow lb/hr	930507.88	260542.21	283360.47	230.49	39662.81	8273.58
Mass Flow lb/hr						
TDA	0.00	0.00	5146.06	51.98	1.03	0.00
O2	129.93	36.38	36.38	0.00	0.00	0.00
CO	7786.08	2180.10	2180.10	0.00	0.00	0.00
TDI	0.00	0.00	0.70	0.01	39656.97	47.18
WATER	0.16	0.05	0.05	0.00	4.81	8226.39
TDCARB	0.00	0.00	17671.51	178.50	0.00	0.00
SOLVENT	922591.71	258325.68	258325.68	0.00	0.00	0.01

Process Material Balance:*Table 5: Process Material Balance*

Inlet Stream	Flow Rate (lb/hr)	Outlet Stream	Flowrate (lb/hr)
TDA	27962.73	WASTEWTR	8273.58
O2	6126.27	TDI	39662.81
CO	12798.09	SLUDGE	230.49
SOLVENT	95.34		
O2MAKEUP	1183.96		
Total	48166.40		48166.90

Table 5 clearly shows that the mass conservation law is upheld by our process. The five inlet streams (TDA, O2, CO, and SOLVENT fed to R-100 & O2MAKEUP fed to R-102) have a combine flow rate of 48,166.40 pounds per hour. The three outlet streams (WASTEWTR and TDI from D-102 & SLUDGE from D-100) have a combined flow rate of 48,166.90 pounds per hour which is extremely close to the inlet flow rates.

Process Description

Process Description

Block Flow Diagram

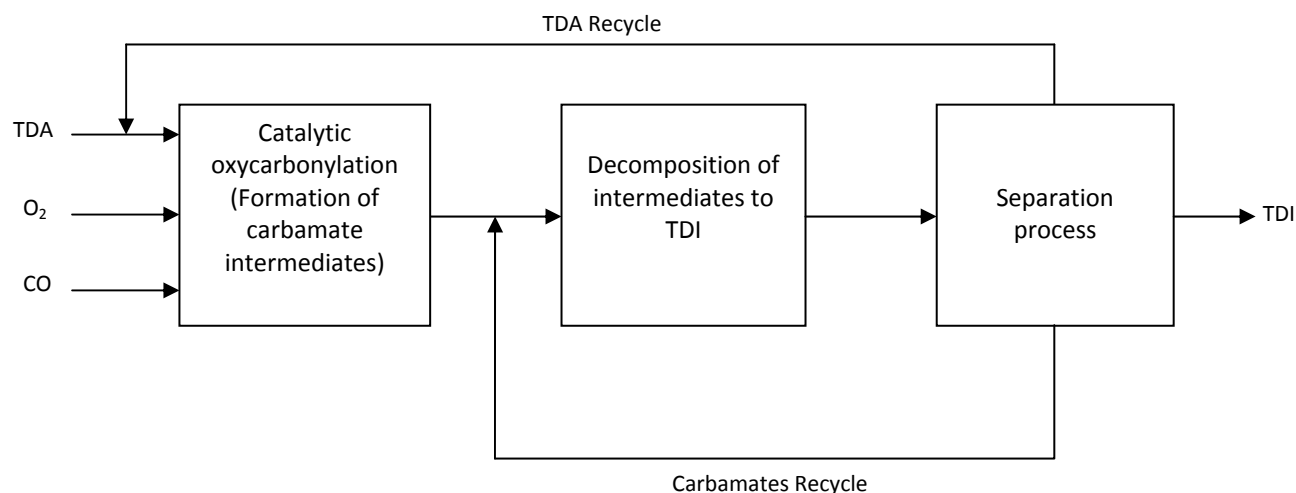

Figure 12. Block flow diagram for the TDI production

Overall Process Description

The block flow diagram given by **Figure 12** illustrates the flows to and from the key sections of the phosgene-free TDI production process. The conversion from TDA to TDI is accomplished through a two-step catalytic reaction carried out between 120°C and 180°C (248°F – 356°F) and 5 – 100 bar (72.5psia - 1450psia). There are two reactors in the process, which work to maximize hourly yield. The reactors in this process are allowed to operate non adiabatically with the feeds entering into the reactor at 120°C (248°F), the bottom of the optimal temperature range, and there is a temperature increase to 139.3°C (282.8°F) in the first reactor and a temperature increase to 137.5°C (279.5°F) in the second reactor. The first step in

the reaction involves the oxycarbonylation of TDA, which produces the corresponding isomeric carbamates. The second step involves the decomposition of the carbamates into TDI. Both steps of the reaction occur within one reactor and are facilitated by a Schiff Base-Type Ligand Catalyst that uses cobalt and is fixed to a silica bead solid support and a homogeneous promoter, NaI, that stays completely in solution throughout the process. It is important to note that the solvent used in this process -- 2,2,2-trifluoroethanol (TFE) -- is consumed in the first step and regenerated in the second step. In addition to serving as a necessary intermediate reactant, a significant amount of TFE is needed to maintain stoichiometric amounts of O₂ and CO in the liquid phase for reaction while keeping the O₂ levels below the combustion limit. For this reason, the mass fraction of TFE in the liquid feed to the reactor is very high. The other components that comprise the liquid feed are NaI, TDA, recycled gases and recycled carbamates. Fresh feed streams of gas phase O₂ and CO are bubbled into the reactor to saturate the solution.

The reactor effluent streams containing TDI, H₂O, TFE, NaI, unreacted TDA, carbamates, CO, and O₂ are decompressed and either recycled back through one of the reactors or sent through a train of three low pressure distillation columns for separation. In the first column, the unused TDA and carbamates, as well as the NaI, are taken out as bottoms product and sent to the second reactor. After the next separation step, the solvent and reactant gases are recycled back to the reactor system, and the heavier wastewater and TDI are sent to the third and last distillation column for separation.

Flow Sheet Diagram

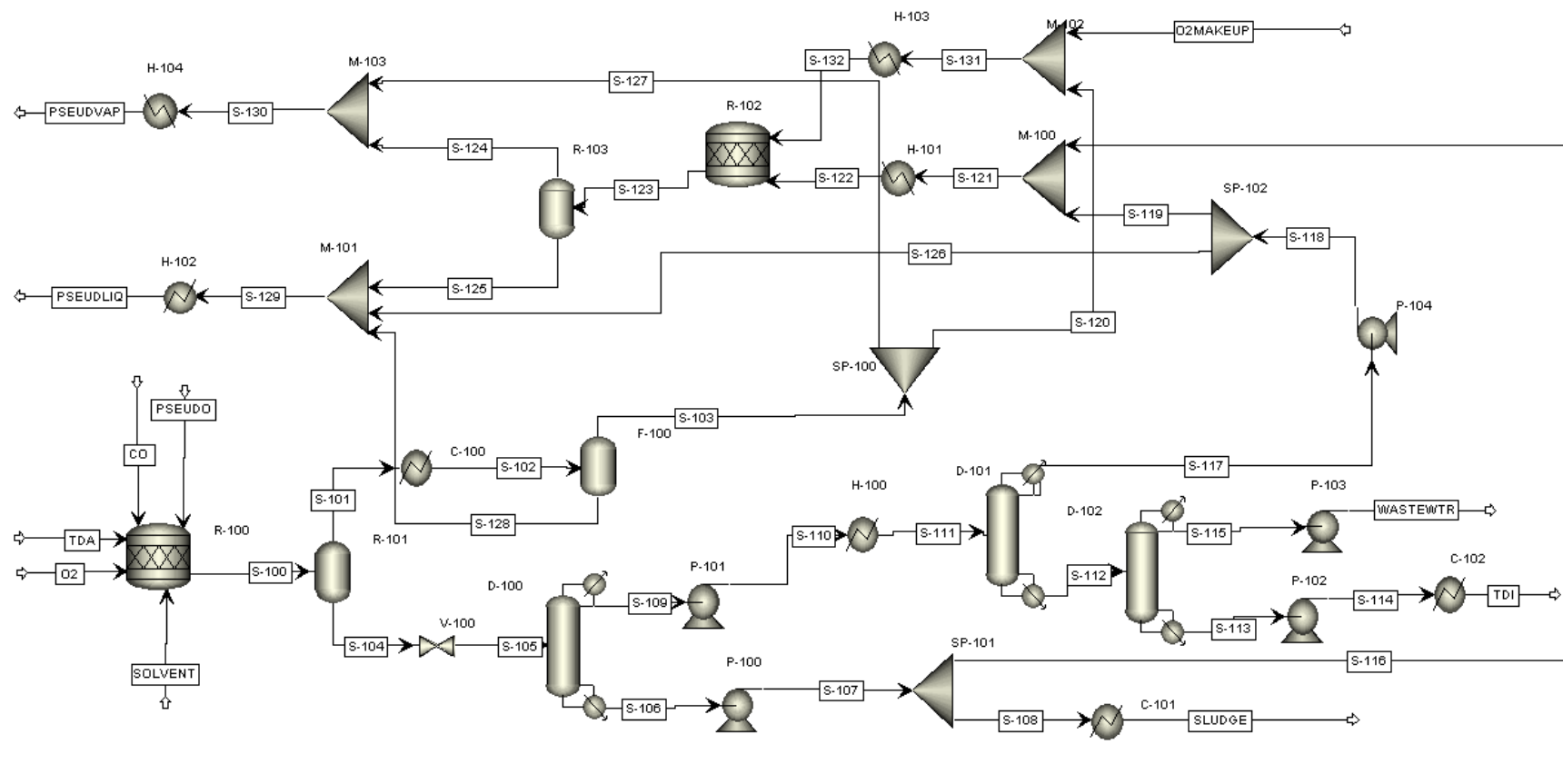

Figure 13 Detailed ASPEN Plus flow sheet of TDI production

Detailed Process Description

Figure 13 is a more comprehensive process flowsheet that gives a detailed view of the equipment and flow streams involved in the TDI production process. There are effectively two major sections of the process – the reaction section and the separation section. Throughout the reaction section, all the streams and equipment are maintained at a high pressure, approximately 653psia (45bar). The separation process section is maintained at low pressure, with a slight pressure drop gradient over the three-column distillation chain from 12psia to 9psia (0.83 to 0.62bar). The stream connecting the reaction section to the separation section is decompressed by a valve, and the streams that gets recycled back from the separation section to the reaction section is compressed by a pump. The valve safely separates the high pressure half of the process from the low pressure half and it acts as a safeguard to make sure that if something goes wrong in the high pressure half it can be isolated from the low pressure half. In addition this allows all of the high pressure piping to be separated from the low pressure piping.

The flowsheet in **Figure 13** shows an open-loop system, but is meant to model a closed-loop system. There are two recycle streams leaving the second reactor system which, in reality would combine to form the total recycle to the first reactor. These streams are separated into vapor (PSEUDVAP) and liquid (PSEUDLIQ). These streams consist of the combination of the exits from the second reactor system and any reactant materials recovered from the separations processes and not fed into the second reactor. Though it is not explicitly illustrated in the flowsheet, PSEUDO VAP is mixed with the O₂ and CO streams and then bubbled into R-100. PSEUDOLIQ will be mixed with the TDA and SOLVENT streams before entering R-100 as a

single liquid feed. Though it is not included in the process simulation, the system will also be charged with a finite amount of promoter, NaI. The addition of NaI into the system flow would not affect the thermodynamics significantly because the amount of NaI needed is negligible relative to total flow. This chemical, however, is highly corrosive and will require most of the reaction system and the first column of the separation system to be coated in Hastelloy® C276. Since the salt is heavy, it should be completely contained within in the bottoms of the first distillation column and recycled back to the reaction section.

Another caveat to **Figure 13** is that the flash vessel R-101 immediately following R-100 is not an actual piece of equipment in the production process, but merely a means of modeling the vapor and liquid effluent from R-100 as two separate streams. This is also the case for R-102 and R-103.

Two-Reactor System

This process requires both a primary reactor (R-100) that processes the bulk of the flow through the system, with an inlet rate of 16145.3 lbmol/hr, and a secondary reactor (R-102), which is fed at a lower flow rate, 3673.04 lbmol/hr, but at a higher concentration of carbamates and a comparable concentration of unreacted TDA. The vapor and liquid feeds into the first reactor are heated to 120°C and compressed to a pressure of 45 bar. R-100 is maintained at 45 bar (653 psia) and reaches a non-adiabatic temperature of approximately 282.74°F, which is still within the optimal temperature range for the reactions; therefore, it is unnecessary to cool the reactor. The recycle stream of TDA, NaI and carbamates (S-106) coming from D-100 is filtered for sludge (S-108/SLUDGE) and compressed to 45 bar (653psia). This stream (S-116) is then

mixed with a part of the compressed solvent recycle stream (S-119), which is 28.0% of the total solvent recycle stream. This combined stream (S-121) is heated to 248°F and fed to R-102. The other split from stream S-118 called S-126 is combined with two other reactor streams to be recycled to R-100 as PSEUDLIQ. The given split fractions of the recycle streams were calculated based on the amount of TFE needed to dissolve the O₂ and CO in the vapor effluent and on the cost- and yield-optimal reactor size of the second reactor. The second reactor is also maintained at 45 bar and increases to a temperature of 279.5°F. Both the liquid and vapor effluent streams (S-124 and S-125) from R-102 are mixed with the recycle streams from separations that are subsequently fed R-100 in the following manner. S-125 is mixed with part of the R-100 liquid effluent (S-126) and eventually fed back to R-100 as PSEUDLIQ. PSEUDLIQ will be mixed with the TDA and SOLVENT feed liquids and fed into the reactor as a single liquid feed. S-124 is mixed with part of the R-100 vapor effluent, S-127, and refeed to R-100 as PSEUDVAP. PSEUDVAP will be mixed with the O₂ and CO gas feeds prior to being fed to the reactor as a single vapor feed which will be bubbled into the system.

Both reactors have an effective product yield of 64% (82% conversion from TDA to carbamates, 78% conversion from carbamates to TDI). This particular reactor system design was chosen over the number of considered alternatives because it is the most cost effective with regard to yield and equipment cost. The streams fed into the first reactor are tabulated for reference in **Table 3**. CO, O₂, TDA and SOLVENT are supplied as fresh feeds or makeup streams based on consumption or loss of the reactants elsewhere in the process.

With the exception of the vapor phase in the two reactors, all of the CO and O₂ in the system must be dissolved into the TFE, because in the gas phase it is necessary to maintain a

19:1 ratio of CO to O₂ to remain outside of the explosion risk range. In order to maintain safe gaseous concentrations, the reactors are initially charged with a CO and O₂ mixture significantly greater than the prescribed 19:1 ratio. During regular operation, CO and O₂ are bubbled into the reactor solution at only a little over a 2:1 ratio (2.39:1), the respective stoichiometric ratio for the reaction. Because the gases are added just at or below their saturation point in the solvent, the initial composition of the gas phase in the reactor does not decrease significantly. However, as a preventative measure, it is still necessary to include a control feedback mechanism that monitors the component concentrations in the vapor phase of the reactor and controls the CO and O₂ feed rates in response.

Separation Process

We will be running a somewhat “traditional” separations process by using distillation to separate our final product, TDI, from the byproducts and any leftover reactants. To accomplish the desired separations, the process required 3 distillation columns. The only stream entering the separations from the reactors section is the bottoms liquid from the first reactor.

The stream connecting the reaction to the separation section, S-104, must be decompressed from 45bar to 0.345bar (653psia to 5psia), since all three distillation columns are operating at very low pressures. D-100 separates the TDA, carbamates, Nal and sludge out as the heavy components in the bottoms product (S-106) at a rate of 90.2 lbmol/hr. This stream is then recompressed to 653psia and a side stream is taken out to remove sludge before being recycled back to the reaction section. The flowsheet shows a splitter with an outgoing sludge stream at a split fraction of 1% to model the estimated sludge removal necessary to prevent

buildup. As mentioned earlier, it is necessary for D-100 to be coated in Hastelloy® C276 because of the volume of NaI that will be flowing through it. The distillate (S-109) from D-100 is compressed from 2psia to 12psia and heated from 35°F to 120°F before entering D-101 for the next separation step. The D-101 distillate (S-117) contains almost all (99.99%) of the solvent that enters the separation system. This stream is compressed and recycled back to the reaction system. The bottoms (S-112) are fed straight into the third distillation column, D-102. S-112 is almost purely TDI and wastewater. Wastewater comes out as distillate (WASTEWTR) at about 99.4% purity, with a negligible amount of TDI and trace amounts of TDA and solvent. This wastewater stream will be stored and shipped to a treatment center to be disposed of as outlined in EPA regulations discussed in the “Other Considerations” section of this report. The bottoms product of D-102 is 99.9% pure TDI at 352.2°F and 2.01psia. This final product is cooled to 140°F and sent to storage.

A final note regarding the separations of our process is a black box design, not pictured in the figure, which will contain a white film evaporator. The white film evaporator will be used to dispose of the heavy polymeric sludge material produced in the first distillation column as a result of processing TDI at such high temperatures. We assumed a loss of about 4-6% of our product due to this polymeric sludge waste. In response, we built in a 5% overproduction of TDI to account for this unavoidable loss.

Energy Balance and Utility Requirements

Energy Balance

One of the major concerns in this process was the amount of heating and cooling which is needed, primarily in the three distillation columns. While it is known that distillation is both energy intensive and an energetically inefficient process, it was still deemed the best separation method to isolate the pure TDI.

One area where energy was managed to be saved was by operating the two reactors non-adiabatically. Each reactor system was modeled in aspen, and the non-adiabatic temperature rise was found for the entering composition of each reactor. According to the patent, the reaction will occur between 212 F and 392 F, and it has an optimal temperature range between 248 F and 356 F. Because the effect of operating in a non-optimal temperature range is unknown, the feed streams to the reactor were kept at 248 F, and the exit temperature after a non-adiabatic reaction was found to be 282.7 F for the first reactor and 279.5 F for the second reactor. Since both of these temperatures were still in the optimal temperature range for the reaction, it was chosen to operate the reactors non-adiabatically and not spend energy to maintain a constant temperature in the reactor. The first reactor would have required the removal of over 44 MBtu per hour to maintain it at 248 F, and the second reactor would have required the removal of over 8.8 MBtu per hour to maintain it at 248 F. This decision saved roughly \$150,000 in cooling water.

As seen in **Table 6**, there were still 5 streams that needed to be heated and 3 streams that needed to be cooled. **Table 7** shows that each of the three distillation columns had both a condenser and a reboiler that require large amounts of energy. Stream S-121 requires 20.6 MBtu per hour to heat the stream from 75 F to 248 F to preheat the liquid stream going into the second reactor. Stream S-110 requires 173.4 MBtu per hr to heat the stream from 35 F to 120 F to preheat the liquid stream entering the second distillation column. Stream S-129 requires 78.5 MBtu per hour to heat the stream from 119 F to 248 F to preheat the liquid recycle stream. Stream S-131 requires 1.0 MBtu per hour to heat the stream from 106 F to 248

Table 6: Streams in reactor block that need to be heated or cooled

Block	stream in	stream out	T _{in} (°F)	T _{out} (°F)	Heat Duty (Btu/hr)	HX	T after HX (°F)
C-101	S-108	SLUDGE	521	140	27,856		
H-101	S-121	S-122	75	248	20,608,058	HX 1 - 3	120
C-102	S-114	TDI	352	140	3,194,100	HX 2 - 2	206
C-100	S-101	S-102	283	100	49,543,000	HX 2 - 1	184
H-100	S-110	S-111	35	120	173,360,000	HX 1 - 4	96
H-102	S-129	PSEUDLIQ	119	248	78,486,221	HX 1 - 2	199
H-103	S-131	S-132	106	248	982,735	HX 1 - 1	201
H-104	S-130	PSEUDVAP	209	248	1,866,485		

F to preheat the vapor stream entering the second reactor. Stream S-130 requires 1.9 MBtu per hour to heat the stream from 209 F to 248 F to preheat the vapor recycle stream. Stream S-108 requires the removal of 28,000 Btu per hour to cool the stream from 521 F to 140 F to cool the sludge stream to below the OSHA temperature limit for personal protection. Similarly, stream S-114 requires the removal of 3.2 MBtu per hour to cool the stream from 352 F to 140 F to cool the TDI stream to below the OSHA temperature limit for personal protection. Stream S-101 requires the removal of 49.5 MBtu per hour to cool the stream from 283 F to 100 F to cool the vapor stream exiting the reactor to allow it to be flashed and separate the vapor components in

the stream, which are sent to the second reactor, from the liquid components which are then recycled back to the first reactor.

The condenser on the first distillation column requires the removal of 729.9 MBtu per hour and it needs to cool the stream from 203.1 F to 35 F as well as condense the stream. The reboiler on the first distillation column requires 625.5 MBtu per hour and it heats the stream

Table 7: Streams in separation block that need to be heated or cooled

Block	stream out	stream out	T _{in} (°F)	T _{out} (°F)	Heat Duty (Btu/hr)	HX	T after HX (°F)
Dist1Con	S-109	Dist1top	203.05	34.98	729,901,000	HX 1	37
Dist1Reb	S-106	Dist1bot	465.75	517.84	625,534,000		
Dist2Con	S-117	Dist2top	93.23	34.09	351,769,000		
Dist2Reb	S-112	Dist2bot	181.88	200.71	182,883,000	HX 2	204
Dist3Con	S-115	Dist3top	114.50	101.71	8,628,050		
Dist3Reb	S-113	Dist3bot	264.38	352.20	10,186,900		

from 465.8 F to 517.8 F before vaporizing the stream. The condenser on the second distillation column requires the removal of 351.8 MBtu per hour to cool the stream from 93.2 F to 34.1 F and then condense the stream. The reboiler on the second distillation column requires 182.9 MBtu per hour to heat the stream from 181.9 F to 200.7 F and then vaporize the stream. The third distillation column has much more moderate energy requirements because it has a much lower flow rate. The condenser on the column only requires the removal of 8.6 MBtu per hour to cool the stream from 114.5 F to 101.7 F and then condense it. The reboiler on the third distillation column requires 10.2 MBtu per hour to heat the stream from 264.4 F to 352.2 F and then vaporize the stream. This comes to a total heating requirement of 1,094 MBtu per hour and a total cooling requirement of 1,143.1 MBtu per hour.

Because this is an excessively high energy requirement, it is vital that cross stream heat exchange be used as much as possible to minimize the utilities needs of the process. First, the

streams that must be heated but are hotter than any of the streams that need to be cooled are ruled out for cross stream heat exchange. By this process, S-106 (the reboiler out stream from the first distillation column) was ruled out. Similarly, any streams that need cooling but are colder than the streams that need heating cannot be used for cross stream heat exchange. Initially there are no values that match this description. After pairing up the stream two separate heat exchanger networks were set up as shown by **Table 8**.

The first network, HX 1, involves 5 streams; the condenser of the first distillation column is the hot stream for all four heat exchangers in the network, and it is paired with 4 streams that need heating, S-131, S-129, S-121, and S-110. Originally S-129 was placed first in the order, because it has the highest initial temperature, but then no energy was available for stream S-131 because the hot stream would leave the first heat exchanger cooler than S-131. Because of this, S-131 and S-129 were changed in the order so that the most energy could be removed from both streams. There is 661,000 Btu per hour exchanged over HX 1 – 1, 38.9 MBtu per hour exchanged over HX 1 – 2, 4.6 MBtu per hour exchanged over HX 1 – 3, and 34.4 MBtu per hour exchanged over HX 1 – 4. This means that 78.6 MBtu per hour is removed from the condenser of the first distillation column. After the heat exchange, S-131's temperature is

201°F and it still needs

Table 8: Energy saved per stream.

HX	Energy Needed (Btu/hr)	HX Energy (Btu/hr)	savings	Energy Left (Btu/hr)
HX 1 - 1	982,735	660,603	67.22%	322,132.4
HX 1 - 2	78,486,221	38,886,131	49.55%	39,600,089.7
HX 1 - 3	20,608,058	4,649,530	22.56%	15,958,528.4
HX 1 - 4	173,360,000	34,428,316	19.86%	138,931,683.9
HX 1	729,901,000	78,624,580	10.77%	651,276,420.1
HX 2 - 1	49,543,000	32,467,349	65.53%	17,075,650.7
HX 2 - 2	3,194,100	2,295,339	71.86%	898,760.8
HX 2	182,883,000	34,762,689	19.01%	148,120,311.5

322,000 Btu per hour to be reach 248 F. S-129 is at 199 F and it still needs 39.6 MBtu per hour to be heated to 248 F. S-122 is at

120 F and still needs 16 MBtu per hour to be heated to 248 F, and S-110 is at 96 F and requires 138.9 MBtu per hour to be heated to 120 F. The hot stream was lowered to 37 F, and it still required 651.3 MBtu per hour to be removed for it to get down to 35 F and then condense the stream.

The second network, HX 2, involves three streams; the stream in the reboiler of the second distillation column is the cold stream for both heat exchangers, and it is paired with S-114 and S-101 which are both hot streams that need cooling. S-101 is placed first because it is not as hot as S-114. 32.5 MBtu per hour is exchanged over HX 2 – 1, and 2.3 MBtu per hour over HX 2 – 2. This means that 34.8 MBtu per hour is put into the reboiler of the second distillation column. After the heat exchangers, S-101 is at 184 F and it still needs 17 MBtu per hour to be removed for it to get to 100 F, and S-114 is at 206 F and it still needs to remove 0.9 MBtu per hour to get to 140 F. The cold stream is raised to 204 F which is higher than its final temperature should be, but it still needs 148.1 MBtu per hour to vaporize.

Some streams, such as S-108,

Total Heat/Cool Req. (Btu/hr)	Total Heat/Cool Savings (Btu/hr)	Savings by saved (%)
1,093,907,399	113,387,268	10.37%
1,143,063,006	113,387,268	9.92%

were left out of the heat exchanger network because the energy that they

would contribute to the network is so

little that the temperature change due to pressure drop over the exchanger would more than offset the contribution of the stream. The remaining streams that were not included into the network did not have a suitable partner. The total energy savings shown in **Table 9** of 113.4 MBtu per hour in both cooling and heating represents 10.4% of the heating requirement and

9.9% of the cooling requirement. This means \$240,000 is saved in cooling water and \$3 million in steam costs.

Other techniques to help lower the utility cost in the distillation columns are also considered. One idea is to use two parallel distillation columns in place of the first distillation column (because that is the column where most of the utility cost is). This alternative, however, does not save any energy. It in fact increases the cooling duty by 75% and it increases the

	Condenser Heat Duty (Btu/hr)	Reboiler Heat Duty (Btu/hr)	Column Diameter	Reflux Ratio
D1-1	638,667,560	586,347,970	9.97	4.95
D1-2	1,277,335,120	1,172,695,940	9.97	4.95
D1	729,892,881	625,253,709	9.57	2.4
Difference	547,442,239	547,442,231		
% Difference	175%	188%		

heating duty by 88%. These results can be seen in **Table 10**.

Table 10: Possible heat duty savings summary by using two parallel distillation columns in place of D-100

Utilities Requirements

Cooling water

Cooling water is required for all 6 streams that require cooling even after the heat exchanger system as seen in **Table 11**. The condenser on the first distillation column requires more than 20,000,000,000 gallons of cooling water per year, which costs \$1.65 million per year.

Table 11: Utility cost of cooling water

Utility type Subroutine handled	Cooling water D-100	Cooling water D-102	Cooling water D-103	Cooling water C-100	Cooling water C-102	Cooling water C-101
Cooling water						
Heat duty, Q (btu/hr)	651,276,420	351,769,000	8,628,050	17,075,651	898,761	27,856
Specific heat of water (Btu/lb-F)	1	1	1	1	1	1
Inlet water temp (F)	90	90	90	90	90	90
Outlet water temp (F)	120	120	120	120	120	120
delta T of water	30	30	30	30	30	30
density of water (lb/gal)	8.33	8.33	8.33	8.33	8.33	8.33
Water vol rate req. (gal/hr)	2,606,148	1,407,639	34,526	68,330	3,596	111
Water vol rate req. (gal/year)	20,640,693,266	11,148,501,321	273,446,002	541,173,083	28,484,136	882,847
Utility cost						
Unit price:						
Cooling water (\$/1000 gal)	\$0.075	\$0.075	\$0.075	\$0.075	\$0.075	\$0.075
Adjusted cooling water cost (CE index for 2010 = 532.7)	\$0.080	\$0.080	\$0.080	\$0.080	\$0.080	\$0.080
Cost per year (\$/year)	\$1,649,913.82	\$891,155.45	\$21,857.91	\$43,258.67	\$2,276.88	\$70.57

The condenser on the second distillation column requires 11.1 billion gallons of cooling water per year, which comes out to \$891,156 per year. The condenser on the third distillation column requires 273 million gallons of cooling water per year, which comes out to \$21,858 per year. The cooler C-100 still requires 541 million gallons per year of cooling water which will cost \$43,259 yearly. The cooler C-102 requires 28.5 million gallons per year of cooling water which will cost \$2,277 yearly. The last cooler, C-101, only requires 883,000 gallons per year of cooling water which will cost \$71 a year.

Steam

The bottom of the first distillation column is so hot that steam cannot be used to heat it up; instead a fired reboiler must be used. For this fired reboiler, fuel oil was used as the utility. The second distillation column also benefits if it uses a fired reboiler rather than steam. Steam is used for the heaters and the third distillation column reboiler as seen in **Table 12**. The third distillation column can though use a steam reboiler, it will require 70.3 million pounds of low pressure steam per year which will cost \$224,799 every year. The heater H-100 needs 1.11 billion pounds of low pressure steam per year, costing \$3.5 million per year. H-101 needs 175

Table 12: Utility cost of steam.

Utility type Subroutine handled	Steam D-102	Steam D-103	Steam H-100	Steam H-101	Steam H-102	Steam H-103	Steam H-104
Steam							
Heat duty, Q (Btu/hr)	148,120,312	8,628,054	138,931,684	15,958,528	39,600,090	322,132	1,866,485
Operating pressure (psi)	13.9	13.9	7	648	639.669819	639.669819	639.669819
delH(vap) (Btu/hr)	971.946	971.946	991.824	723.209	723.209	723.209	723.209
Steam flow rate req. (lb/hr)	152,396	8,877	140,077	22,066	54,756	445	2,581
Steam flow rate req. (lb/year)	1,206,973,296	70,306,571	1,109,409,468	174,764,895	433,668,152	3,527,733	20,440,229
Steam type	low pressure	low pressure	low pressure	low pressure	low pressure	low pressure	low pressure
Utility cost							
Unit price:							
Low pressure steam (\$/1000 lb)	\$3.00	\$3.00	\$3.00	\$3.00	\$3.00	\$3.00	\$3.00
Adjusted cooling water cost (CE index for 2010 = 532.7)	\$3.20	\$3.20	\$3.20	\$3.20	\$3.20	\$3.20	\$3.20
Cost per year (\$/year)	\$3,859,176.42	\$224,798.23	\$3,547,225.83	\$558,793.28	\$1,386,610.55	\$11,279.58	\$65,355.59

million pounds of low pressure steam per year which will cost \$558,794 a year. H-102 needs 434 million pounds of low pressure steam per year which will cost \$1.4 million a year. H-103 requires 3.53 million pounds of low pressure steam per year which will cost \$11,279 a year. Finally H-104 requires 20.4 million pounds of low pressure steam per year which will cost \$65,356 yearly.

Fuel Oil and Solid Waste**Table 13: Utility cost of fuel oil.**

Utility type Subroutine handled	Fuel oil HX-106	Fuel oil HX-107
Fuel Oil		
Heat duty, Q (Btu/hr)	625,534,412	148,120,311
Density of fuel oil (lb/gal)	7.43	7.43
Amount of natural gas supplied (lb/hr)	2,640,357	925,752
Amount of natural gas supplied (gal/hr)	355,364	124,596
Amount of natural gas supplied (gal/year)	2,814,484,991	986,804,228
Utility cost		
Unit price:		
Natural gas (\$/1000 scf)	\$1.50	\$1.50
Adjusted cooling water cost (CE index for 2010 = 532.7)	\$1.60	\$1.60
Cost per year (\$/year)	\$4,499,517.15	\$1,577,603.92

Table 14: Utility cost of landfill.

Utility type Material handled	Landfill Sludge
Solid waste	
Amount (lb/hr)	230
Amount (lb/year)	1,825,465
Utility cost	
Unit price:	
Landfill (\$/dry lb)	\$0.10
Adjusted landfill cost (CE index for 2010 = 532.7)	\$0.11
Cost per year (\$/year)	\$194,558

The first distillation column's fired reboiler will use 2.81 billion gallons per year of fuel oil which will cost \$4.5 million, and the second distillation column's fired reboiler will use 987 million gallons per year of fuel oil which will cost \$1.6 million. 1.83 million pounds of solid waste are produced each year by this process which means that there will

be a yearly cost of \$195,558 to dump the waste in a landfill. The handling and transportation cost is included as a percentage of the total fixed cost. These values are shown in **Table 13** and

Table 14.**Electricity**

Finally, we also need to supply electricity through the use of electric motors accompanying every pump we have placed throughout the TDI production process. The details can be found in **Table 29** in Appendix 4.

Equipment List and Unit Descriptions

Unit Descriptions:

The following section is the description on what every unit does throughout the process. Detailed sizing and costing calculations can be found in Appendix 1 and in the relevant unit specification sheets.

Reactor R-100 & R-101:

R-100 and R-101 are combined to form a horizontal, fixed-bed, autoclave reactor. The gases, CO and O₂, are bubbled vigorously through the liquid from the bottom creating a continuously stirred tank reactor system. The reactor works at a temperature of 282.765°F and a pressure of 652.67 psi. It looks like in certain places you are using English units and in certain places SI units (when you talked about the suitable temp for reactions). It would be better to unify the units. The fixed bed is composed of the Co- tBu- Salen catalyst. The reactor is made out of carbon steel with a ¼ inch Hastelloy C coating on the inside to prevent corrosion by the NaI promoter. The reactor has a diameter of 35.92 ft and a length of 143.68 ft. Its bare module cost is \$14,984,247.

Reactor R-102 & R-103:

R-102 and R-103 are combined to form a horizontal, fixed-bed, autoclave reactor. The gases, CO and O₂, are bubbled vigorously through the liquid from the bottom creating a continuously stirred tank reactor system. The reactor works at a temperature of 282.765°F and a pressure of 652.67 psi. The fixed bed is composed of the Co- tBu- Salen catalyst. The reactor is made out of carbon steel with a ¼ inch Hastelloy C coating on the inside to prevent corrosion

by the NaI promoter. The reactor is approximately $\frac{1}{3}$ the size of the first and has a diameter of 21.85 ft and a length of 87.39 ft. Its bare module cost is \$4,056,812.

Cooler C-100:

C-100 is a fixed head shell and tube cooler used to cool the vapor from the first reactor system which will be fed to the flash drum. The main reason for this cooler is to lower the temperature of the vapor from the first reactor so that the quantity of the product, TDI, vaporized in the reactor can be recovered and sent to separations. The cooler is made out of carbon steel shell with a $\frac{1}{4}$ inch Hastelloy C coating to prevent corrosion by the NaI promoter. The tubes are 20 ft in length, and the area available for heat transfer is 3913.27 ft². The hot vapor stream enters at 184°F and leaves at 100°F. The cooling streaming enters at 90°F and leaves at 120°F. The pressure drop through the cooler is 5 psi, and the cooler heat duty is – 17,075,650.7 Btu/hr. The bare module cost of this cooler is \$88,092.

Flash drum F-100:

F-100 is a vertical two phase flash drum which is used to separate the solvent and gases from the rest of the material in the vapor stream from the first reactor. The solvent and gases are sent to be further reacted in the second reactor system while the liquid bottoms (TDA, TDI, Water and remaining CO, O₂, TDCARB, and SOVENT) are sent back to R-100 as part of PSEDUOUT. The flash drum is made out of carbon steel. The vessel has an estimated residence time at half full of 5 minutes and a volume of 4957.21 ft³. The diameter is 14.67 ft and the length is 29.34 ft. The vessel operates at a temperature of 99.91°F and a pressure of 644.67 psi. The bare module cost of the flash drum is \$203,926.

Splitter SP-100:

SP-100 is a splitter used to split S-103 into 0.3 S-120 which will be sent to R-102 and 0.7 S-127 which will be sent back to R-100 as part of PSEUDOUT.

Stream Mixer M-100:

M-100 is used to model the combination of streams S-116, S-119, S-120, O2MAKEUP, and S-121 which will be sent to the second reactor.

Heater H-101:

H-101 is a fixed head shell and tube heater used to heat the feed to R-102. The heater is made out of carbon steel shell with a ¼ inch Hastelloy C coating to prevent corrosion by the NaI promoter. The tubes are 20 ft in length, and the area available for heat transfer is 1329.88 ft². The pressure drop through the cooler is 5 psi, and the heater heat duty is 15,958,528.41 Btu/hr. The bare module cost of this heater is \$135,554.

Mixer M-101:

M-101 is used to model the combination of streams S-124, S-125, S-126, S-127, S-128, AND S-129 which will be mixed to form the PSEUDLIQ stream. This stream would be fed to the first reactor.

Heater H-102:

H-102 is a fixed head shell and tube heater used to heat the PSEUDLIQ stream which will be recycled to R-100. The heater is made out of carbon steel shell with a ¼ inch Hastelloy C

coating to prevent corrosion by the NaI promoter. The tubes are 20 ft in length, and the area available for heat transfer is 3300.01 ft². The pressure drop through the cooler is 5 psi, and the heater heat duty is 39,600,089.7 Btu/hr. The bare module cost of this heater is \$214,773.

Valve V-100:

V-100 is a diaphragm valve which is used as a safety measure to separate the high reaction and low separation pressures in the process. Steam S-104, from the first reactor system, enters the valve at 652.67 psia, and stream S-105 leaves the valve at 5 psia. The pressure drop across the valve is 647.67 psi. The bare module cost of this heater is \$301,962.

Distillation Column D-100:

D-100 is a 20 stage carbon steel distillation column with a ¼ Hastelloy C coating to prevent corrosion by the NaI promoter. The column has 19 Koch Flexitray trays with a tray spacing of 2ft, and it has a height of 52 ft (assuming a 10ft for the sump and 4 ft for the space above the top tray). The column has a diameter of 9.7 ft. There is an estimated 0.15 psi pressure drop per stage, and the top stage is at 11 psi. To help decrease the necessary size of the column, it is packed from stage 2-19 with Koch Flexipac with a dimension of 500Y. The column has a reflux ratio of 2.4. The distillate is removed at a temperature of 34.98°F, and the bottoms is removed at 465.75°F. The bare module cost of this column is \$1,219,952.

Pump P-100:

P-100 is a centrifugal pump which is used to pump the bottoms from D-100 to the second reactor system. It is made of cast iron and has a ¼ inch Hastelloy C coating to prevent

corrosion by the NaI promoter. The pump has a volumetric flow rate of 280.408 cuft/hr and a pressure change of 648.1 psi while generating a head of 13624.774 inches. The pump motor is assumed to be explosion-proof with a shaft rotation of 3600 rotations per minute. The electricity requirement to run the pump is 12.3198 KW, and the pump efficiency is 0.8. This pump has a bare module cost of \$57,306.

Splitter SP-101:

SP-101 is a splitter used to split S-107 into 0.99 S-116 which will be sent to R-102 and 0.01 S-108 which is the sludge from D-100 which will be sent to storage.

Cooler C-101:

C-101 is a fixed head shell and tube cooler used to cool the sludge bottoms from D-101 which will be sent to storage. The cooler is made out of carbon steel shell with a ¼ inch Hastelloy C coating to prevent corrosion by the NaI promoter. The tubes are 20 ft in length, and the area available for heat transfer is 6.61 ft². The hot sludge stream, S-108 enters at 521.1°F and leaves at 140°F. The cooling streaming enters at 90°F and leaves at 120°F. The pressure drop through the cooler is 5 psi, and the cooler heat duty is -27,856.499Btu/hr. The bare module cost of this cooler is \$53,159.

Pump P-101:

P-101 is a centrifugal pump which is used to pump the tops from D-100 to be fed to D-101. It is made of cast iron and has a ¼ inch Hastelloy C coating to prevent corrosion by the NaI promoter. The pump has a volumetric flow rate of 9784.44 cuft/hr and a pressure change of 10

psi while generating a head of 172.8 inches. The pump motor is assumed to be explosion-proof with a shaft rotation of 3600 rotations per minute. The electricity requirement to run the pump is 6.63 KW, and the pump efficiency is 0.8. This pump has a bare module cost of \$57,774.

Heater H-100:

H-100 is a fixed head shell and tube heater used to preheat the top liquid from D-100 which will be fed to D-101. The heater is made out of carbon steel shell. The tubes are 20 ft in length, and the area available for heat transfer is 11577.64 ft². The pressure drop through the cooler is 5 psi, and the heater heat duty is 138,931,683.9 Btu/hr. The bare module cost of this heater is \$517,879.

Distillation Column D-101:

D-101 is a 20 stage carbon steel distillation column. The column has 19 Koch Flexitray trays with a tray spacing of 2ft, and it has a height of 52 ft (assuming a 10ft for the sump and 4 ft for the space above the top tray). The column has a diameter of 30.35 ft. There is an estimated 0.15 psi pressure drop per stage, and the top stage is at 10 psi. To help decrease the necessary size of the column, it is packed from stage 2-19 with Koch Flexipac with a dimension of 500Y. The column has a reflux ratio of 1.05. The distillate is removed at a temperature of 34.09°F, and the bottoms is removed at 200.71°F. The bare module cost of this column is \$2,566,983.

Pump P-104:

P-104 is a centrifugal pump which is used to pump the tops from D-101 to be fed to both reactors. It is made of cast iron. The pump has a volumetric flow rate of 9155.70 cuft/hr and a pressure change of 648 psi while generating a head of 11017.68 inches. The pump motor is assumed to be explosion-proof with a shaft rotation of 3600 rotations per minute. The electricity requirement to run the pump is 402.196 KW, and the pump efficiency is 0.8. This pump has a bare module cost of \$251,744.

Splitter SP-102:

SP-102 is a splitter used to split S-118 into 0.28 S-119 which will be sent to R-102 and 0.72 S-126 which will sent back to R-100 as part of PSEUDOUT.

Distillation Column D-102:

D-100 is a 19 stage carbon steel distillation. The column has 11 Koch Flexitray trays with a tray spacing of 2ft, and it has a height of 36 ft (assuming a 10ft for the sump and 4 ft for the space above the top tray). The column has a diameter of 4.19 ft. There is an estimated 0.15 psi pressure drop per stage, and the top stage is at 1 psi. To help decrease the necessary size of the column, it is packed from stage 2-7 with Koch Flexipac with a dimension of 2X. The column has a reflux ratio of 3.2. The distillate is removed at a temperature of 101.71°F, and the bottoms is removed at 352.20°F. The bare module cost of this column is \$385,015.

Pump P-102:

P-102 is a centrifugal pump which is used to pump the TDI bottoms product from D-102 to storage. It is made of cast iron. The pump has a volumetric flow rate of 604.575 cuft/hr and a pressure change of 5 psi while generating a head of 131.70 inches. The pump motor is assumed to be explosion-proof with a shaft rotation of 3600 rotations per minute. The electricity requirement to run the pump is .32930 KW, and the pump efficiency is 0.5. This pump has a bare module cost of \$21,050.

Cooler C-102:

C-102 is a fixed head shell and tube cooler used to cool the TDI bottoms product from D-102 which will be sent to storage. The cooler is made out of carbon steel shell. The tubes are 20 ft in length, and the area available for heat transfer is 135.39 ft². The hot TDI stream, S-113 enters at 206°F and leaves at 140°F. The cooling stream enters at 90°F and leaves at 120°F. The pressure drop through the cooler is 5 psi, and the cooler heat duty is -898,760.8 Btu/hr. The bare module cost of this cooler is \$24,791.

Pump P-103:

P-103 is a centrifugal pump which is used to pump the waste water top product from D-102 to storage. It is made of cast iron. The pump has a volumetric flow rate of 135.091 cuft/hr and a pressure change of 5 psi while generating a head of 141.07 inches. The pump motor is assumed to be explosion-proof with a shaft rotation of 3600 rotations per minute. The electricity requirement to run the pump is .12390 KW, and the pump efficiency is 0.3. This pump has a bare module cost of \$25,404.

TDA Storage Tank ST-100:

ST-100 is a carbon steel storage tank used to hold the TDA starting material. This tank holds 1week's worth of TDA at a temperature of 248°F and a pressure of 652.67 psia. The volume of the vessel is 73,017 cuft, and it has a purchase cost of \$243,316.

TFE Makeup Storage Tank ST-101:

ST-101 is a carbon steel storage tank used to hold the SOLVENT makeup. This tank holds 1week's worth of SOLVENT makeup at a temperature of 248°F and a pressure of 652.67 psia. The volume of the vessel is 199 cuft, and it has a purchase cost of \$3,462.

Carbon Monoxide Storage Tank ST-102:

ST-102 is a carbon steel storage tank used to hold the CO starting material. This tank holds 1week's worth of CO at a temperature of 248°F and a pressure of 652.67 psia. The volume of the vessel is 896,650 cuft, and it has a purchase cost of \$2,731,981.

Oxygen Storage Tank ST-103:

ST-103 is a carbon steel storage tank used to hold the O₂ starting material. This tank holds 1week's worth of O₂ at a temperature of 248°F and a pressure of 653 psia. The volume of the vessel is 444,514 cuft, and it has a purchase cost of \$2,020,415.

TFE Storage Tank ST-104:

ST-104 is a carbon steel storage tank used to hold the TFE solvent. This tank holds 3 hours' worth of TFE at a temperature of 248°F and a pressure of 639.67 psia. The volume of the vessel is 54,571 cuft, and it has a purchase cost of \$197,296.

Waste Water Storage Tank ST-105:

ST-105 is a carbon steel storage tank used to hold the WASTE WATER. This tank holds 1weeks worth of WASTE WATER at a temperature of 101.7°F and a pressure of 6 psia. The volume of the vessel is 22,696 cuft, and it has a purchase cost of \$104,902.

Sludge/Solid Waste Storage Tank ST-106:

ST-106 is a carbon steel rail storage tank used to hold the SLUDGE from the bottoms of D-100. This tank holds 1weeks worth of SLUDGE at a temperature of 168°F and a pressure of 648 psia. The volume of the vessel is 395 cuft, and it has a purchase cost of \$5,679.

TDI Product Storage Tank ST-107:

ST-107 is a carbon steel rail car storage used to hold the TDI product. This tank holds 1weeks worth of TDI product at a temperature of 140°F and a pressure of 2.01 psia. The volume of the vessel is 90,520 cuft, and it has a purchase cost of \$284,026.

Recycle Stream Intermediate Storage Tank ST-108:

ST-108 is a carbon steel storage tank used to hold the PSEUDOUT to be recycled to R-100. This tank holds 1 hours' worth of PSEUDOUT at a temperature of 248°F and a pressure of 639.67 psia. The volume of the vessel is 66,654 cuft, and it has a purchase cost of \$227,854.

Heater H-103:

H-103 is a fixed head shell and tube heater used to preheat the top liquid from D-100 which will be fed to D-101. The heater is made out of carbon steel shell. The tubes are 20 ft in length, and the area available for heat transfer is 26.84 ft². The pressure drop through the cooler is 5 psi, and the heater heat duty is 322,132.4 Btu/hr. The bare module cost of this heater is \$134,065.

Heater H-104:

H-104 is a fixed head shell and tube heater used to preheat the top liquid from D-100 which will be fed to D-101. The heater is made out of carbon steel shell. The tubes are 20 ft in length, and the area available for heat transfer is 155.54 ft². The pressure drop through the cooler is 5 psi, and the heater heat duty is 1,866,485 Btu/hr. The bare module cost of this heater is \$134,583.

M-102:

M-102 is used to model the combination of S-127, part of the flash drum vapor stream, and S-124, the vapor stream coming off the top of the second reactor. The streams combine to form S-130 which will be fed back to the first reactor as the PSEUDVAP stream.

M-103:

M-103 is used to model the combination of O2MAKEUP, the the oxygen makeup necessary to be fed into the second reactor, and S-120, par of the vapor stream coming off the top of the flash drum. The streams combine to form S-131 which will be the gas feed back to the second reactor system.

Heat Exchanger HX-100:

HX-100 models the heat exchanger that transfers energy from the hot stream, S-109, going into the condenser of column 1, D-100, to the cold stream, S-131, that is the vapor feed going into the second reactor, R-101. The hot stream temperature in is 203°F and the hot stream temperature out is 202°F. The cold stream temperature in is 106°F and the cold stream temperature out is 201°F. The heat duty is 660,603 Btu/hr.

Heat Exchanger HX-101:

HX-101 models the heat exchanger that transfers energy from the hot stream, S-109, going into the condenser of column 1, D-100, to the cold stream, S-129, that is the liquid recycle stream going back into the first reactor, R-100. The hot stream temperature in is 202°F and the hot stream temperature out is 122°F. The cold stream temperature in is 119°F and the cold stream temperature out is 199°F. The heat duty is 38,886,131 Btu/hr.

Heat Exchanger HX-102:

HX-102 models the heat exchanger that transfers energy from the hot stream, S-109, going into the condenser of column 1, D-100, to the cold stream, S-121, that is the liquid feed

going into the second reactor, R-101. The hot stream temperature in is 122°F and the hot stream temperature out is 112°F. The cold stream temperature in is 75°F and the cold stream temperature out is 120°F. The heat duty is 4,649,530 Btu/hr.

Heat Exchanger HX-103:

HX-103 models the heat exchanger that transfers energy from the hot stream, S-109, going into the condenser of column 1, D-100, to the cold stream, S-110, that is the stream entering the second distillation column, D-101. The hot stream temperature in is 112°F and the hot stream temperature out is 37°F. The cold stream temperature in is 35°F and the cold stream temperature out is 96°F. The heat duty is 34,428,316 Btu/hr.

Heat Exchanger HX-104:

HX-104 models the heat exchanger that transfers energy from the hot stream, S-101, the vapor stream leaving the first reactor, R-100, that is cooled before entering the flash vaporization vessel, F-100, to the cold stream, S-112, that is going into the reboiler of distillation column 2, D-101. The hot stream temperature in is 283°F and the hot stream temperature out is 184°F. The cold stream temperature in is 182°F and the cold stream temperature out is 204°F. The heat duty is 32,467,349 Btu/hr.

Heat Exchanger HX-105:

HX-105 models the heat exchanger that transfers energy from the hot stream, S-114, the TDI exit stream which must be cooled to be stored, to the cold stream, S-112, that is going into the reboiler of distillation column 2, D-101. The hot stream temperature in is 352°F and the

hot stream temperature out is 206°F. The cold stream temperature in is 204°F and the cold stream temperature out is 204°F. The heat duty is 2,295,339 Btu/hr.

Heat Exchanger (Hot Oil System) HX-106:

HX-106 models the fired reboiler that replaces the traditional steam reboiler of the first distillation column, D-100, because the temperature at the bottom of that column is too hot for steam to be used. The stream is heated to 518°F and then vaporized using 625,534,000 Btu/hr.

Heat Exchanger (Hot Oil System) HX-107:

HX-107 models the fired reboiler that replaces the traditional steam reboiler of the second distillation column, D-101. The stream is vaporized using 148,120,312 Btu/hr.

Unit Specification Sheets

Cooler		
Identification: Item HEATER		Date: 4/4/2010
Item No.	C-100	
No. Required	1	
Function: To cool the top vapor from R-101 to be fed to F-100		
Operation Continuous		
Materials handled:		
	<u>Inlet Stream</u>	<u>Outlet Stream</u>
Stream ID:	S-101	S-102
Quantity (lb/hr):	2.9297+05	2.9297+05
Composition:		
TDA	1.1713	1.1713
O2	993.5	993.5
CO	1.0325+05	1.0325+05
TDI	34.1342	34.1342
WATER	417.0485	417.0485
TDCARB	7.6870-03	7.6870-03
SOLVENT	1.8828+05	1.8828+05
Temperature (°F):	100	
Pressure (psi):	647.67	
Design Data:		
Material of Construction:	Carbon Steel with Hastelloy coating	
Pressure Drop	5 psi	
Heat Duty	(-)1707565 Btu	
U	150 Btu/hr-ft ² -F	
Area	3913.271 ft ²	
Comment The purpose of this cooler is to cool the vapor of the first reactor so that any TDI that was vaporized during the reaction can be recovered and sent to separations.		

Cooler		
Identification: Item HEATER		Date: 4/4/2010
Item No.	_____	C-101
No. Required	_____	1
Function: To cool the SLUDGE stream from D-100 for storage		
Operation Continuous		
Materials handled:		
	<u>Inlet Stream</u>	<u>Outlet Stream</u>
Stream ID:	S-108	SLUDGE
Quantity (lb/hr):	230.4875	230.4875
Composition:		
TDA	51.9804	51.9804
O2	0.0	0.0
CO	0.0	0.0
TDI	7.0220-03	7.0220-03
WATER	2.2736-24	2.2736-24
TDCARB	178.5001	178.5001
SOLVENT	7.8200-20	7.8200-20
Temperature (^o F):	140	
Pressure (psi):	648	
Design Data:		
Material of Construction:	Carbon Steel with Hastelloy coating	
Pressure Drop	5	psi
Heat Duty	(-)27856.499	Btu/hr
U	25	Btu/hr-ft ² -F
Area	6.608	ft ²
Comments:		

Cooler		
Identification: Item HEATER		Date: 4/4/2010
Item No.	C-102	
No. Required	1	
Function: To cool the TDI product stream from the bottom of D-102 for storage		
Operation Continuous		
Materials handled:		
	<u>Inlet Stream</u>	<u>Outlet Stream</u>
Stream ID:	S-114	TDI
Quantity (lb/hr):	3.9663+04	3.9663+04
Composition:		
TDA	1.0299	1.0299
O2	0.0	0.0
CO	0.0	0.0
TDI	3.9657+04	3.9657+04
WATER	4.8083	4.8083
TDCARB	0.0	0.0
SOLVENT	6.5681-12	6.5681-12
Temperature (⁰ F):	140	
Pressure (psi):	2.077	
Design Data:		
Material of Construction:	Carbon Steel with Hastelloy coating	
Pressure Drop	5	psi
Heat Duty	(-) 898760.8	Btu
U	100	Btu/hr-ft ² -F
Area	135.39	ft ²
Comment The point of this cooler is to cool the TDI product to 140 °F which is the OSHA requirement for storage without the need of special heatsafe gear.		

Pump & Motor	
Identification: Item Pump Date: 4/4/2010	
Item No. D-100 REBOILER PUMP	
No. Requi 1	
Function: To pump the bottoms of D-100 to be refed underneath the bottom tray	
Operation Continuous	
Materials handled:	
	<u>STREAM</u>
Stream ID:	S-106
Quantity (lb/hr):	23048.75
Composition:	
TDA	5198.0
O2	0.0
CO	0.0
TDI	0.702195
WATER	2.27E-22
TDCARB	17850.0
SOLVENT	7.82E-18
Temperature (^o F):	517.84
Pressure (psi):	4.9
Design Data:	
Type:	Centrifugal
Volumetric Flow Rate:	280.398420924574 cuft/hr
Pressure Change:	0.15 psi
Electricity Required:	6.63296 kW
Efficiency:	0.386078
Comments:	

Pump & Motor	
Identification: Item Pump Date: 4/4/2010	
Item No. D-100 REFLUX PUMP	
No. Requi 1	
Function: To pump the tops of D-100 to be refed above the top tray	
Operation Continuous	
Materials handled:	
	<u>STREAM</u>
Stream ID:	S-109
Quantity (lb/hr):	978444.3
Composition:	
TDA	1.029994
O2	129.9303
CO	7786.079
TDI	39704.15
WATER	8231.36
TDCARB	3.6472-30
SOLVENT	922591.7
Temperature (⁰ F):	34.981
Pressure (psi):	2
Design Data:	
Type:	Centrifugal
Volumetric Flow Rate:	33267.66752232 cuft/hr
Pressure Change:	0.0922660000000004 psi
Electricity Required:	6.63296 KW
Efficiency:	0.85249
Comments:	

Distillation column			
Identification: Item RADFRAC Distillation Column		Date: 4/4/2010	
Item No.	D-100		
No. Required	1		
Function: To separate heavies (TDA and TDCARB) from SOLVENT(TFE), O2, CO, Water, & TDI			
Operation Continuous			
Materials handled:			
	<u>Inlet Feed</u>	<u>Top Out</u>	<u>Bottom Out</u>
Stream ID:	S-105	S-109	S-106
Quantity (LB/HR):	1001493	978444.3	23048.75
Composition:			
	<i>TDA</i>	5199.073	1.029994 5198.043
	O2	129.9303	129.9303 1.47E-46
	CO	7786.079	7786.079 3.62E-47
	TDI	39704.85	39704.15 0.702195
	WATER	8231.36	8231.36 2.27E-22
	TDCARB	17850.01	3.65E-30 17850.01
	SOLVENT	922591.7	922591.7 7.82E-18
Temperature (^o F): Top = 34.98, Bot. = 517.84			
Design Data:			
Material:	Carbon Steel with a 1/4 inch Hastelloy Coating		
Stages:	20		
Pressure:	11psi		
Pressure drop per stage:	0.15psi		
Diameter:	9.57ft		
Height:	52ft		
Tray Spacing:	2ft		
Tray Type:	Koch Flexitray		
Comments:			

Reflux Accumulator	
Identification: Item Horizontal Reflux Accumulator Tank	
Date: 4/4/2010	
Item No. D-100 ACCUMULATOR	
No. Required 1	
Function: To accumulate excess tops from D-100 to be fed to fed to reflux pump	
Operation: Continuous	
Materials handled:	
	Reflux
	<u>Stream</u>
Stream ID:	S-109
Quantity (lb/hr):	978444.3
Composition:	
TDA	1.029994
O2	129.9303
CO	7786.079
TDI	39704.15
WATER	8231.36
TDCARB	3.6472-30
SOLVENT	922591.7
Temperature (^o F):	34.981
Pressure (psi):	2 psi
Design Data:	
Material:	Carbon Steel
Pressure:	2 psi
Molar Reflux Ratio:	2.4
Height:	12.0848262248967 ft
Vapor Fraction:	0
Hold-up Time:	5 min
Comments:	

Condenser	
Identification: Item Condenser	Date: 4/4/2010
Item No. D-100 CONDENSER	
No. Required 1	
Function: To condense the tops of D-100	
Operation: Continuous	
Materials handled:	
	<u>D-100 Condenser</u>
Stream ID:	S-109
Quantity (lb/hr):	978444.3
Composition:	
TDA	1.029994
O2	129.9303
CO	7786.079
TDI	39704.15
WATER	8231.36
TDCARB	3.6472-30
SOLVENT	922591.7
Inlet temperatur (in F):	
Outlet Temperature (in F):	
Design Data:	
Material of Construction:	Stainless Steel
Heat Duty:	651472422.5 btu/hr
Utilities:	Cooling Water
Type:	Total
Comments:	

Reboiler	
Identification: Item Distillation Reboiler Date: 4/4/2010	
Item No. D-100 REBOILER	
No. Required 1	
Function: To reheat the bottoms of the column which will be reintroduced to the column as vapor	
Operation: Continuous	
Materials handled:	
<u>D-100 REBOILER</u>	
Stream ID:	S-106
Quantity (lb/hr):	23048.75
Composition:	
TDA	5198.043
O2	1.47E-46
CO	3.62E-47
TDI	0.702195
WATER	2.27E-22
TDCARB	17850.01
SOLVENT	7.82E-18
Inlet Temperature (°F)	465.75
Outlet Temperature (°)	517.842
Design Data:	
Material of Construction: Carbon Steel with 1/4 inch Hastelloy coating	
Heat Duty: 625534412 Btu/hr	
Utilities: 13.9 psi Steam	
Type: Kettle	
Comments:	

Pump & Motor	
Identification: Item Pump Date: 4/4/2010	
Item No.	D-101 REBOILER PUMP
No. Required	1
Function: To pump the bottoms of D-101 to be refed underneath the bottom tray	
Operation Continuous	
Materials handled:	
	<u>STREAM</u>
Stream ID:	S-112
Quantity (lb/hr):	47936.39
Composition:	
TDA	1.029994
O2	8.18E-26
CO	1.06E-26
TDI	39704.15
WATER	8.23E+03
TDCARB	0
SOLVENT	9.78E-03
Temperature (^o F):	200.71
Pressure (psi):	7.8
Design Data:	
Type:	Centrifugal
Volumetric Flow Rate:	709.85324300311 cuft/hr
Pressure Change:	0.15 psi
Electricity Required:	6.63296 KW
Efficiency:	0.519631
Comments:	

Pump & Motor	
Identification: Item Pump Date: 4/4/2010	
Item No. D-101 REFLUX PUMP	
No. Requi 1	
Function: To pump the tops of D-101 to be refed above the top tray	
Operation Continuous	
Materials handled:	
	<u>STREAM</u>
Stream ID:	S-117
Quantity (lb/hr):	930507.9
Composition:	
TDA	6.64E-44
O2	129.9303
CO	7786.079
TDI	1.45E-30
WATER	0.162563
TDCARB	0.0
SOLVENT	922591.7
Temperature (°F):	34.092
Pressure (psi):	5
Design Data:	
Type:	Centrifugal
Volumetric Flow Rate:	18768.5864395356 cuft/hr
Pressure Change:	0.0922660000000004 psi
Electricity Required:	6.63296 KW
Efficiency:	0.825443
Comments:	

Distillation column				
Identification: Item RADFRAC Distillation Column		Date: 4/4/2010		
Item No. D-101				
No. Required 1				
Function: To separate SOLVENT (TFE), CO, and O2 from Water and TDI				
Operation: Continuous				
Materials handled:				
		<u>Inlet Feed</u>	<u>Top Out</u>	<u>Bottom Out</u>
Stream ID:		S-111	S-117	S-112
Quantity (LB/HR):		978444.3	930507.882	47936.3895
Composition:				
	<i>TDA</i>	1.029994	0.0	1.02999379
	O2	129.9303	129.930304	8.18E-26
	CO	7786.079	7786.07937	1.06E-26
	TDI	39704.15	1.45E-30	39704.152
	WATER	8231.36	0.1625633	8231.1978
	TDCARB	3.65E-30	0.0	0.0
	SOLVENT	922591.7	922591.709	0.00977767
Temperature (°F):		Top = 34.09, Bot. = 200.71		
Design Data:				
Material:	Carbon Steel			
Stages:	20			
Pressure:	10psi			
Pressure drop per stage:	.15psi			
Diameter:	30.35ft			
Height:	52ft			
Tray Spacing:	2ft			
Tray Type:	Koch Flexitray			
Comments:				

Reflux Accumulator		
Identification: Item	Horizontal Reflux Accumulator Tank Item No. D-101 ACCUMULATOR No. Required 1	Date: 4/4/2010
Function:	To accumulate excess tops from D-101 to be fed to fed to reflux pump	
Operation:	Continuous	
Materials handled:	Reflux	
	<u>Stream</u>	
Stream ID:	S-117	
Quantity (lb/hr):	930507.9	
Composition:		
TDA	6.64E-44	
O2	129.9303	
CO	7786.079	
TDI	1.45E-30	
WATER	0.162563	
TDCARB	0.0	
SOLVENT	922591.7	
Temperature (°F):	34.092	
Pressure (psi):	5 psi	
Design Data:		
Material:	Carbon Steel	
Pressure:	5 psi	
Molar Reflux Ratio:	1.05	
Height:	9.98566090073922 ft	
Vapor Fraction:	0	
Hold-up Time:	5 min	
Comments:		

Condenser	
Identification: Item Condenser Date: 4/4/2010	
Item No. _____	D-101 CONDENSER
No. Required	1
Function: To condense the tops of D-101	
Operation Continuous	
Materials handled:	
	<u>D-101 Condenser</u>
Stream ID:	S-117
Quantity (lb/hr):	930507.9
Composition:	
TDA	6.64E-44
O2	129.9303
CO	7786.079
TDI	1.45E-30
WATER	0.162563
TDCARB	0.0
SOLVENT	922591.7
Inlet temperatur (°F)	34.092
Outlet Temperature	34.1
Design Data:	
Material of Construction:	Stainless Steel
Heat Duty:	351768841 btu/hr
Utilities:	Cooling Water
Type:	Total
Comments:	

Reboiler	
Identification: Item Distillation Reboiler Date: 4/4/2010	
Item No. D-101 REBOILER	
No. Required 1	
Function: To reheat the bottoms of the column which will be reintroduced to the column as vapor	
Operation: Continuous	
Materials handled:	
<u>D-101 REBOILER</u>	
Stream ID:	S-112
Quantity (lb/hr):	47936.39
Composition:	
TDA	1.029994
O2	8.18E-26
CO	1.06E-26
TDI	39704.15
WATER	8.23E+03
TDCARB	0
SOLVENT	9.78E-03
Inlet Temperature (°F)	181.88
Outlet Temperature (°)	200.71
Design Data:	
Material of Construction:	Carbon Steel
Heat Duty:	148120311.5 Btu/hr
Utilities:	13.9 psi Steam
Type:	Kettle
Comments:	

Pump & Motor	
Identification: Item Pump	
Date:	4/4/2010
Item No.	D-102 REBOILER PUMP
No. Requi	1
Function: To pump the bottoms of D-102 to be refed underneath the bottom tray	
Operation Continuous	
Materials handled:	
	<u>STREAM</u>
Stream ID:	S-113
Quantity (lb/hr):	39662.81
Composition:	
TDA	1.029915
O2	0
CO	0
TDI	39656.97
WATER	4.808312
TDCARB	0
SOLVENT	6.57E-12
Temperature (^o F):	352.2
Pressure (psi):	2.0077
Design Data:	
Type:	Centrifugal
Volumetric Flow Rate:	604.616027439024 cuft/hr
Pressure Change:	0.092266 psi
Electricity Required:	6.63296 KW
Efficiency:	0.498037
Comments:	

Pump & Motor	
Identification: Item Pump Date: 4/4/2010	
Item No. D-102 REFLUX PUMP	
No. Requi 1	
Function: To pump the tops of D-102 to be refed above the top tray	
Operation Continuous	
Materials handled:	
	<u>STREAM</u>
Stream ID:	S-115
Quantity (lb/hr):	8273.578
Composition:	
TDA	7.90E-05
O2	0.0
CO	0.0
TDI	4.72E+01
WATER	8226.389
TDCARB	0.0
SOLVENT	0.009778
Temperature (^o F):	101.7
Pressure (psi):	1
Design Data:	
Type:	Centrifugal
Volumetric Flow Rate:	136.06256363243 cuft/hr
Pressure Change:	0.0922660000000004 psi
Electricity Required:	6.63296 KW
Efficiency:	0.267787
Comments:	

Distillation column			
Identification: Item RADFRAC Distillation Column		Date: 4/4/2010	
Item No. D-102			
No. Required 1			
Function: To separate Water and TDI			
Operation: Continuous			
Materials handled:			
Stream ID:	Inlet Feed	Top Out	Bottom Out
Quantity (LB/HR):	S-112	S-115	S-113
Composition:	47936.39	8273.57811	39662.8114
TDA	1.029994	0.0	1.02991481
O2	8.18E-26	0.0	0
CO	1.06E-26	0.0	0
TDI	39704.15	47.1787663	39656.9732
WATER	8231.198	8226.38949	4.80831193
TDCARB	0.0	0.0	0.0
SOLVENT	0.009778	0.00977767	6.57E-12
Temperature (^o F): Top = 101.71, Bot. = 352.20			
Design Data:			
Material:	Carbon Steel		
Stages:	12		
Pressure:	1psia		
Pressure drop per stage:	.15psi		
Diameter:	4.19ft		
Height:	36ft		
Tray Spacing:	2ft		
Tray Type:	Koch Flexitray		
Comments:			

Reflux Accumulator	
Identification: Item	Horizontal Reflux Accumulator Tank Item No. D-102 ACCUMULATOR No. Required 1
	Date: 4/4/2010
Function: To accumulate excess tops from D-102 to be fed to fed to reflux pump	
Operation: Continuous	
Materials handled:	
	Reflux
	<u>Stream</u>
Stream ID:	S-115
Quantity (lb/hr):	8273.578
Composition:	
TDA	7.90E-05
O2	0.0
CO	0.0
TDI	4.72E+01
WATER	8226.389
TDCARB	0.0
SOLVENT	0.009778
Temperature (^o F):	101.7
Pressure (psi):	1 psi
Design Data:	
Material:	Carbon Steel
Pressure:	1 psi
Molar Reflux Ratio:	0.007
Height:	1.93261720784302 ft
Vapor Fraction:	0
Hold-up Time:	5 min
Comments:	

Condenser	
Identification: Item Condenser	
Date:	4/4/2010
Item No.	D-102 CONDENSER
No. Required	1
Function: To condense the tops of D-102	
Operation: Continuous	
Materials handled:	
	<u>D-102 Condenser</u>
Stream ID:	S-115
Quantity (lb/hr):	8273.578
Composition:	
TDA	7.90E-05
O2	0.0
CO	0.0
TDI	4.72E+01
WATER	8226.389
TDCARB	0.0
SOLVENT	0.009778
Inlet temperatur (in F):	
Outlet Temperature (in F):	
Design Data:	
Material of Construction:	Stainless Steel
Heat Duty:	8628054.3 btu/hr
Utilities:	Cooling Water
Type:	Total
Comments:	

Reboiler	
Identification: Item Distillation Reboiler Date: 4/4/2010	
Item No. D-102 REBOILER	
No. Required 1	
Function: To reheat the bottoms of the column which will be reintroduced to the column as vapor	
Operation: Continuous	
Materials handled:	
<u>D-102 REBOILER</u>	
Stream ID:	S-113
Quantity (lb/hr):	39662.81
Composition:	
TDA	1.029915
O2	0.00E+00
CO	0.00E+00
TDI	39656.97
WATER	4.81E+00
TDCARB	0
SOLVENT	6.57E-12
Inlet Temperature (°F)	264.38
Outlet Temperature (°)	352.2
Design Data:	
Material of Construction:	Carbon Steel
Heat Duty:	8628054.3 Btu/hr
Utilities:	13.9 psi Steam
Type:	Kettle
Comments:	

Flash Drum			
Identification: Item		Vertical Flash Drum	Date: [Date]
	Item No.	F-100	
	No. Required	1	
Function: To separate the gases and solvent to be sent to R-102 and liquid bottoms to be sent back to R-100			
Operation: Continuous			
Materials handled:			
		Inlet Stream	Top Stream
Stream ID:		S-102	S-103
Quantity (lb/hr):		292971.018	84460.84
Composition:			Bottom Stream
	TDA	1.17130117	5.19E-08
	O2	993.537324	672.3039
	CO	103246.652	81428.69
	TDI	34.1342455	0.000107
	WATER	417.048468	0.228977
	TDCARB	0.00768696	7.69E-13
	SOLVENT	188278.467	2359.616
Temperature (^o F):	99.91		
Pressure (psi):	644.67		
Design Data:			
	Material:	Carbon Steel with 1/4" Hastelloy Coating	
	Vapor Fraction:	0.525	
	Half Full Residence Time:	5 min	
	Diameter:	14.67 ft	
	Length:	29.34 ft	
	Shell Thickness:	0.75 in	
Comments:			

Heater		
Identification: Item HEATER		Date: 4/4/2010
Item No.	H-100	
No. Required	1	
Function: To preheat the top liquid of D-100 to be fed to D-101		
Operation: Continuous		
Materials handled:		
	<u>Inlet Stream</u>	<u>Outlet Stream</u>
Stream ID:	S-110	S-111
Quantity (lb/hr):	9.7844+05	9.7844+05
Composition:		
TDA	1.03	1.03
O2	129.9303	129.9303
CO	7786.079	7786.079
TDI	3.9704+04	3.9704+04
WATER	8231.36	8231.36
TDCARB	3.6472-30	3.6472-30
SOLVENT	9.2259+05	9.2259+05
Temperature (°F):	120	
Pressure (psi):	7	
Design Data:		
Type	Kettle Vaporizer	
Material of Construction:	Carbon Steel	
Pressure Drop	5	psi
Heat Duty	138931683.9	Btu/hr
Utility Fluid	Low Pressure Steam	
Utility Required	140077	lb/hr
Comments:		
To avoid boiling, assume heat flux of 12000 Btu/hr ² -ft ²		

Heater		
Identification: Item HEATER		Date: 4/4/2010
Item No. H-101		
No. Requi 1		
Function: To heat the liquid feed to R-102		
Operation Continuous		
Materials handled:		
	<u>Inlet Stream</u>	<u>Outlet Stream</u>
Stream ID:	S-121	S-122
Quantity (lb/hr):	3.0988+05	3.0988+05
Composition:		
TDA	5146.062	5146.062
O2	1422.207	1422.207
CO	2.6609+04	2.6609+04
TDI	0.6952	0.6952
WATER	0.1142	0.1142
TDCARB	1.7672+04	1.7672+04
SOLVENT	2.5903+05	2.5903+05
Temperature (⁰ F):	248	
Pressure (psi):	639.67	
Design Data:		
Type	Kettle Vaporizer	
Material of Construction:	Carbon Steel with Hastelloy coating	
Pressure Drop	5	psi
Heat Duty	15958528.41	Btu/hr
Area	1329.9	ft ²
Utility Required	22066.27	lb/hr
Comments:		
To avoid boiling, assume heat flux of 12000 Btu/hr ² -ft ²		

Heater		
Identification: Item HEATER		Date: 4/4/2010
Item No.	H-102	
No. Required	1	
Function: To preheat the liquid stream to be recycled to R-100		
Operation: Continuous		
Materials handled:		
	<u>Inlet Stream</u>	<u>Outlet Stream</u>
Stream ID:	S-129	PSEUDOUT
Quantity (lb/hr):	1.2475+06	1.2475+06
Composition:		
TDA	927.4625	927.4625
O2	1202.179	1202.179
CO	1.0910+05	1.0910+05
TDI	1.0287+04	1.0287+04
WATER	1661.714	1661.714
TDCARB	8567.397	8567.397
SOLVENT	1.1157+06	1.1157+06
Temperature (°F):	248	
Pressure (psi):	639.67	
Design Data:		
Type	Kettle Reboiler	
Material of Construction:	Carbon Steel with Hastelloy coating	
Pressure Drop	5	psi
Heat Duty	39600089.7	Btu/hr
Area	3300	ft ²
Utility Required	54756.08	lb/hr
Comments:		
To avoid boiling, assume heat flux of 12000 Btu/hr ² -ft ²		

Heater		
Identification: Item HEATER		Date: 4/4/2010
Item No.	H-103	
No. Required	1	
Function: To heat the gas stream to be fed to R-102		
Operation: Continuous		
Materials handled:		
	Inlet Stream	Outlet Stream
Stream ID:	S-129	PSEUDOUT
Quantity (lb/hr):	1.2475+06	1.2475+06
Composition:		
TDA	927.4625	927.4625
O2	1202.179	1202.179
CO	1.0910+05	1.0910+05
TDI	1.0287+04	1.0287+04
WATER	1661.714	1661.714
TDCARB	8567.397	8567.397
SOLVENT	1.1157+06	1.1157+06
Temperature (°F):	248	
Pressure (psi):	639.67	
Design Data:		
Type	Kettle Reboiler	
Material of Construction:	Carbon Steel	
Pressure Drop	5	psi
Heat Duty	322132.4	Btu/hr
Area	26.8	ft ²
Utility Required	445.4209	lb/hr
Comments:		
To avoid boiling, assume heat flux of 12000 Btu/hr ² -ft ²		

Heater		
Identification: Item HEATER		Date: 4/4/2010
	Item No. H-104	
	No. Requi 1	
Function: To heat gas recycle stream to be fed to R-100		
Operation Continuous		
Materials handled:		
	<u>Inlet Stream</u>	<u>Outlet Stream</u>
Stream ID:	S-129	PSEUDOUT
Quantity (lb/hr):	1.2475+06	1.2475+06
Composition:		
TDA	927.4625	927.4625
O2	1202.179	1202.179
CO	1.0910+05	1.0910+05
TDI	1.0287+04	1.0287+04
WATER	1661.714	1661.714
TDCARB	8567.397	8567.397
SOLVENT	1.1157+06	1.1157+06
Temperature (⁰ F):	248	
Pressure (psi):	639.67	
Design Data:		
Type	Kettle Reboiler	
Material of Construction:	Carbon Steel	
Pressure Drop	5	psi
Heat Duty	1866484.52	
Area	155.5	ft ²
Utility Required	2580.837	Btu/hr ² -ft ²
Comments:		
To avoid boiling, assume heat flux of 12000 Btu/hr ² -ft ²		

Heat Exchanger				
Identification: Item Heat Exchanger		Date: 4/4/2010		
Item No.	HX-100			
No. Required	1			
Function: To exchange energy between hot and cold streams				
Operation Continuous				
Materials handled:				
Stream ID:	<u>Cold in</u>	<u>Hot in</u>	<u>Hot Out</u>	<u>Cold Out</u>
Quantity (lb/hr):	S-131	S-109	S-109	S-132
Composition:	26522.2	2006412	2006412	26522.2
TDA	0	0	0	0
O2	43.303	0.006	0.006	43.303
CO	872.126	0.578	0.578	872.126
TDI	0	0	0	0
WATER	0.004	0.001	0.001	0.004
TDCARB	0	0	0	0
SOLVENT	7.076	0.415	0.415	7.076
Temperature (^o F):	106	203	202	201
Pressure (psi):	645	2	2	640
Design Data:				
Type	Shell and Tube Heat Exchanger			
Material of Construction:	Carbon Steel			
Heat Duty:	660603	Btu/hr		
Shell Diameter	15.25	in		
Heat Transfer Coefficient:	149.69	Btu/hr-ft ² -F		
Heat Transfer Area	180.63	ft ²		
Comments:				

Heat Exchanger				
Identification: Item Heat Exchanger		Date: 4/4/2010		
Item No.	HX-101			
No. Required	1			
Function: To exchange energy between hot and cold streams				
Operation Continuous				
Materials handled:				
Stream ID:	Cold in	Hot in	Hot Out	Cold Out
Quantity (lb/hr):	S-129	S-109	S-109	PSEUDLIQ
Composition:	1124680.65	2006412	2006412	1124681
TDA	7.59	0	0	7.59
O2	14.067	0.006	0.006	14.067
CO	1037.796	0.578	0.578	1037.796
TDI	59.024	0	0	59.024
WATER	89.302	0.001	0.001	89.302
TDCARB	22.893	0	0	22.893
SOLVENT	10733.445	0.415	0.415	10733.45
Temperature (°F):	119	202	122	199
Pressure (psi):	645	2	2	640
Design Data:				
Type	Shell and Tube Heat Exchanger			
Material of Construction:	Carbon Steel			
Heat Duty:	4649530	Btu/hr		
Shell Diameter:	15.25	in		
Heat Transfer Coefficient:	149.69	Btu/hr-ft ² -F		
Heat Transfer Area:	87906.291	ft ²		
Comments:				

Heat Exchanger					
Identification: Item Heat Exchanger		Date: 4/4/2010			
Item No.		HX-102			
No. Required		1			
Function: To exchange energy between hot and cold streams					
Operation: Continuous					
Materials handled:					
		<u>Cold in</u>	<u>Hot in</u>	<u>Hot Out</u>	<u>Cold Out</u>
Stream ID:		S-121	S-109	S-109	S-122
Quantity (lb/hr):		283361	2006412	2006412	283361
Composition:					
TDA		42.122	0	0	42.122
O2		1.137	0.006	0.006	1.137
CO		77.832	0.578	0.578	77.832
TDI		0.004	0	0	0.004
WATER		0.003	0.001	0.001	0.003
TDCARB		47.22	0	0	47.22
SOLVENT		2582.213	0.415	0.415	2582.213
Temperature (^o F):		75	122	112	120
Pressure (psi):		653	2	2	648
Design Data:					
Type:		Shell and Tube Heat Exchanger			
Material of Construction:		Carbon Steel with 1/4" Hastelloy on Tube Side			
Heat Duty:		4649530	Btu/hr		
Shell diameter:		15.25	in		
Heat transfer coefficient:		149.69	Btu/hr-ft ² -F		
Heat transfer area:		2629.09	ft ²		
Comments:					

Heat Exchanger					
Identification: Item Heat Exchanger		Date: 4/4/2010			
Item No. HX-103					
No. Requi 1					
Function: To exchange energy between hot and cold streams					
Operation Continuous					
Materials handled:					
Stream ID:		<u>Cold in</u>	<u>Hot in</u>	<u>Hot Out</u>	<u>Cold Out</u>
Quantity (lb/hr):		S-110	S-109	S-109	S-111
Composition:		978444	2006412	2006412	978444
	TDA	0.008	0	0	0.008
	O2	4.06	0.006	0.006	4.06
	CO	277.971	0.578	0.578	277.971
	TDI	227.977	0	0	227.977
	WATER	456.91	0.001	0.001	456.91
	TDCARB	0	0	0	0
	SOLVENT	9222.19	0.415	0.415	9222.19
Temperature (^o F):		35	112	37	96
Pressure (psi):		12	2	2	7
Design Data:					
Type:	Shell and Tube Heat Exchanger				
Material of Construction:	Carbon Steel with 1/4" Hastelloy on Tube Side				
Heat Duty:	34428316	Btu/hr			
Shell diameter:	15.25	in			
Heat transfer coefficient:	149.69	Btu/hr-ft ² -F			
Heat transfer area:	190932.4	ft ²			
Comments:					

Heat Exchanger					
Identification: Item Heat Exchanger		Date: 4/4/2010			
Item No. HX-104					
No. Requi 1					
Function: To exchange energy between hot and cold streams					
Operation Continuous					
Materials handled:					
Stream ID:		<u>Cold in</u>	<u>Hot in</u>	<u>Hot Out</u>	<u>Cold Out</u>
Quantity (lb/hr):		S-112	S-101	S-102	S-112
Composition:		708099	292971	292971	708099
	TDA	0	0.01	0.01	0
	O2	0	31.049	31.049	0
	CO	0	3686.011	3686.011	0
	TDI	0.333	0.196	0.196	0.333
	WATER	0.667	23.15	23.15	0.667
	TDCARB	0	0	0	0
	SOLVENT	0	1882.024	1882.024	0
Temperature (^o F):		182	283	184	204
Pressure (psi):		8	626	621	8
Design Data:					
Type:	Shell and Tube Heat Exchanger				
Material of Construction:	Carbon Steel				
Heat Duty:	32467349				
Shell diameter:	15.25	in			
Heat transfer coefficient:	149.69	Btu/hr-ft ² -F			
Heat transfer area:	20138.73	ft ²			
Comments:					

Heat Exchanger					
Identification: Item Heat Exchanger		Date: 4/4/2010			
Item No. HX-105					
No. Requi 1					
Function: To exchange energy between hot and cold streams					
Operation Continuous					
Materials handled:					
Stream ID:		<u>Cold in</u>	<u>Hot in</u>	<u>Hot Out</u>	<u>Cold Out</u>
Quantity (lb/hr):		S-112	S-114	TDI	S-112
Composition:		708099	39663	39663	708099
	TDA	0	0.008	0.008	0
	O2	0	0	0	0
	CO	0	0	0	0
	TDI	0.333	227.706	227.706	0.333
	WATER	0.667	0.267	0.267	0.667
	TDCARB	0	0	0	0
	SOLVENT	0	0	0	0
Temperature (^o F):		204	352	206	204
Pressure (psi):		8	626	621	8
Design Data:					
Type:	Shell and Tube Heat Exchanger				
Material of Construction:	Carbon Steel				
Heat Duty:	2295339	Btu/hr			
Shell diameter:	15.25	in			
Heat transfer coefficient:	149.69	Btu/hr-ft ² -F			
Heat transfer area:	462.55	ft ²			
Comments:					

Pump & Motor		
Identification: Item Pump		Date: 4/4/2010
Item No. _____	P-100	
No. Required	1	
Function: To pump the bottoms of D-100 to be fed to R-102		
Operation Continuous		
Materials handled:		
	<u>Inlet Stream</u>	<u>Outlet Stream</u>
Stream ID:	S-106	S-107
Quantity (lb/hr):	2.3049+04	2.3049+04
Composition:		
TDA	5198.043	5198.043
O2	0.0	0.0
CO	0.0	0.0
TDI	0.7022	0.7022
WATER	2.2736-22	2.2736-22
TDCARB	1.7850+04	1.7850+04
SOLVENT	7.8200-18	7.8200-18
Temperature (^o F):	521.1076	
Pressure (psi):	653	
Design Data:		
Type:	Centrifugal	
Volumetric Flow Rate:	280.408 cuft/hr	
Pressure Change:	648.1 psi	
Electricity Required:	28.672 kW	
Efficiency:	0.78	
Comments:		

Pump & Motor		
Identification: Item Pump		Date: 4/4/2010
Item No.	_____	P-101
No. Required	_____	1
Function: To pump the tops of D-100 to be fed to D-101		
Operation: Continuous		
Materials handled:		
	<u>Inlet Stream</u>	<u>Outlet Stream</u>
Stream ID:	S-109	S-110
Quantity (lb/hr):	978444.271	978444.3
Composition:		
TDA	1.0	1.0
O2	129.9	129.9
CO	7786.1	7786.1
TDI	39704.152	39704.15
WATER	8231.36036	8231.36
TDCARB	0.0	0.0
SOLVENT	922591.719	922591.7
Temperature (^o F):	35.0177	
Pressure (psi):	12	
Design Data:		
Type:	Centrifugal	
Volumetric Flow Rate:	9784.44365 cuft/hr	
Pressure Change:	10 psi	
Electricity Required:	7.8426 kW	
Efficiency:	0.8	
Comments:		

Pump & Motor		
Identification: Item Pump		Date: 4/4/2010
Item No.	P-102	
No. Required	1	
Function: To pump the TDI bottom product from D-102 to storage		
Operation Continuous		
Materials handled:		
	Inlet Stream	Outlet Stream
Stream ID:	S-113	S-114
Quantity (lb/hr):	3.9663+04	3.9663+04
Composition:		
TDA	1.0299	1.0299
O2	0.0	0.0
CO	0.0	0.0
TDI	3.9657+04	3.9657+04
WATER	4.8083	4.8083
TDCARB	0.0	0.0
SOLVENT	6.5681-12	6.5681-12
Temperature (°F):	35.0177	
Pressure (psi):	12	
Design Data:		
Type:	Centrifugal	
Volumetric Flow Rate:	604.575 cuft/hr	
Pressure Change:	5 psi	
Electricity Required:	0.4258 kW	
Efficiency:	0.498	
Comments:		

Pump & Motor		
Identification: Item Pump		Date: 4/4/2010
Item No.	_____	P-103
No. Required	_____	1
Function: To pump the waste water from the top of D-102 to storage		
Operation Continuous		
Materials handled:		
	Inlet Stream	Outlet Stream
Stream ID:	S-115	WASTEWTR
Quantity (lb/hr):	8273.578	8273.578
Composition:		
TDA	7.8987-05	7.8987-05
O2	0.0	0.0
CO	0.0	0.0
TDI	47.1788	47.1788
WATER	8226.39	8226.39
TDCARB	0.0	0.0
SOLVENT	9.7777-.03	9.7777-.03
Temperature (°F):	101.7455	
Pressure (psi):	6	
Design Data:		
Type:	Centrifugal	
Volumetric Flow Rate:	135.091 cuft/hr	
Pressure Change:	5 psi	
Electricity Required:	0.1854 kW	
Efficiency:	0.2666	
Comments:		

Pump & Motor		
Identification: Item Pump		Date: 4/4/2010
Item No.	P-104	
No. Required	1	
Function: To pump the tops of D-101 to be fed to R-100 & R-102		
Operation Continuous		
Materials handled:		
	Inlet Stream	Outlet Stream
Stream ID:	S-117	S-118
Quantity (lb/hr):	9.3051+05	9.3051+05
Composition:		
TDA	0.0	0.0
O2	129.9	129.9
CO	7786.1	7786.1
TDI	1.4506-30	1.4506-30
WATER	0.1626	0.1626
TDCARB	0.0	0.0
SOLVENT	9.2259+05	9.2259+05
Temperature (°F):	36.513	
Pressure (psi):	653	
Design Data:		
Type:	Centrifugal	
Volumetric Flow Rate:	9155.70 cuft/hr	
Pressure Change:	648 psi	
Electricity Required:	443.683 kW	
Efficiency:	0.8	
Comments:		

Reactor		
Identification: Item Horizontal Reactor		Date: 4/4/2010
Item No.	R-100 & R-101	
No. Required	1	
Function: To react the the starting materials to create the products		
Operation: Continuous		
Materials handled:		
Stream ID:	<u>Combines Inlet Stream</u>	<u>Outlet Stream</u>
Quantity (lb/hr):	TDA, O2, CO, SOLVENT, & PSUEDO	RX1MID
Composition:	1.2945+06	1.2945+06
	TDA	5200.244
	O2	1123.468
	CO	1.1103+05
	TDI	3.9739+04
	WATER	8648.409
	TDCARB	1.7850+04
	SOLVENT	9.2259+05
Temperature (⁰ F):	282.765	
Pressure (psi):	652.67	
Design Data:		
Residence Time at Half Full:	60 min	
Material of Construction:	Carbon Steel with Hastelloy coating	
Type:	Fixed Bed Autoclave Reactor	
RXN 1 Heat of Reaction:	(-)150773.43 btu/lbmol	
RXN 2 Heat of Reaction:	(-)12384.795 btu/lbmol	
Volume:	145609.0 ft ³	
Comments:		
The gases will be bubbled up through the liquid causing thorough mixing. Although ASPEN shows R-100 & R-101 as two separate vessels, they will be one single vessel.		

Reactor		
Identification: Item Horizontal Reactor		Date: 4/4/2010
Item No. R-102 & R-103		
No. Requi 1		
Function: To react the the starting materials to create the products		
Operation: Continuous		
Materials handled:		
	Inlet Stream	Outlet Stream
Stream ID:	B4RX2	RX2MID
Quantity (lb/hr):	309882.677	309882.7
Composition:		
TDA	5146.0623	926.2912
O2	1422.02726	316.7826
CO	26608.7099	24673.74
TDI	0.69520548	10252.94
WATER	0.11421085	1244.617
TDCARB	17671.5052	8567.389
SOLVENT	259033.563	263900.9
Temperature (⁰ F):	282.765	
Pressure (psi):	652.67	
Design Data:		
Material of Construction:	Carbon Steel with hastelloy coating	
Type:	Fixed Bed Autoclave Reactor	
Comments:		
The gases will be bubbled up through the liquid causing thorough mixing. Although ASPEN shows R-102 & R-103 as two separate vessels, they will be one single vessel.		

Storage Tank	
Identification: Item Vertical Storage Tank Date: 4/4/2010	
Item No. _____	ST-100
No. Required	1
Function: To store TDA	
Operation Continuous	
Materials handled:	
	<u>Flow</u>
Stream ID:	
Quantity (lb/hr):	27962.73
Composition:	
TDA	27962.73
Temperature (°F):	248
Pressure (psi):	652.67
Design Data:	
Material:	Carbon Steel
Holding Amount:	1 week
Volume:	146035 ft ³
Diameter:	103.714 ft
Length:	17.286 ft
Time Period:	336 hrs
Type	Open
Comments:	

Storage Tank	
Identification: Item Vertical Storage Tank Date: 4/4/2010	
Item No. _____	ST-101
No. Required	1
Function: To store SOLVENT makeup	
Operation Continuous	
Materials handled:	
	<u>Flow</u>
Stream ID:	
Quantity (lb/hr):	95.339
Composition:	
SOLVENT	95.339
Temperature (°F):	248
Pressure (psi):	652.67
Design Data:	
Material:	Carbon Steel
Holding Amount:	1 week
Volume:	199 ft ³
Diameter:	11.493 ft
Length:	1.9156 ft
Time Period:	168 hrs
Type	Open
Comments:	

Storage Tank	
Identification: Item Vertical Storage Tank Date: 4/4/2010	
Item No.	ST-102
No. Required	1
Function: To store CO	
Operation Continuous	
Materials handled:	
Stream ID:	<u>Flow</u>
Quantity (lb/hr):	12798.09
Composition:	
CO	12798.09
Temperature (°F):	248
Pressure (psi):	652.67
Design Data:	
Material:	Carbon Steel
Holding Amount:	1 week
Volume:	896650 ft ³
Diameter:	189.916 ft
Length:	31.653 ft
Time Period:	168 hours
Type	Open
Comments:	

Storage Tank	
Identification: Item Vertical Storage Tank Date: 4/4/2010	
Item No. _____	ST-103
No. Required	1
Function: To store O2	
Operation: Continuous	
Materials handled:	
	<u>Flow</u>
Stream ID:	
Quantity (lb/hr):	7310.222
Composition:	
O2	7310.222
Temperature (°F):	248
Pressure (psi):	653
Design Data:	
	Material: Carbon Steel
	Holding Amount: 1 week
	Volume: 444514 ft ³
	Diameter: 150.308 ft
	Length: 25.051 ft
	Time Period: 168 hours
	Type: Open
Comments:	

Storage Tank	
Identification: Item Vertical Storage Tank Date: 4/4/2010 Item No. ST-104 No. Requi 1	
Function: To store TFE solvent	
Operation Continuous	
Materials handled:	
	<u>Flow</u>
Stream ID:	
Quantity (lb/hr):	1.12E+06
Composition:	
TFE solvent	1.12E+06
Temperature (°F):	248
Pressure (psi):	639.67
Design Data:	
Material:	Carbon Steel
Holding Amount:	1 week
Volume:	54571 ft ³
Diameter:	74.704 ft
Length:	12.451 ft
Time Period:	3 hrs
Type	Open
Comments:	

Storage Tank	
Identification: Item Vertical Storage Tank Date: 4/4/2010	
Item No. _____	ST-105
No. Required	1
Function: To store WASTE WATER	
Operation Continuous	
Materials handled:	
	<u>Flow</u>
Stream ID:	
Quantity (lb/hr):	8273.578
Composition:	
WASTE WATER	8273.578
Temperature (°F):	101.7
Pressure (psi):	6
Design Data:	
Material:	Carbon Steel
Holding Amount:	1 week
Volume:	22696 ft ³
Diameter:	55.762 ft
Length:	9.294 ft
Time Period:	168 hrs
Type	Open
Comments:	

Storage Tank	
Identification: Item Vertical Storage Tank Date: 4/4/2010	
Item No. _____	ST-106
No. Required	1
Function: To store SLUDGE	
Operation Continuous	
Materials handled:	
Stream ID:	<u>Flow</u>
Quantity (lb/hr):	230.488
Composition:	
SLUDGE	230.488
Temperature (^o F):	140
Pressure (psi):	648
Design Data:	
Material:	Carbon Steel
Holding Amount:	1 week
Volume:	395.0 ft ³
Diameter:	14.454 ft
Length:	2.409 ft
Time Period:	168 hrs
Type	Open
Comments:	

Storage Tank	
Identification: Item Vertical Storage Tank Date: 4/4/2010	
Item No. _____	ST-107
No. Required	1
Function: To store TDI	
Operation Continuous	
Materials handled:	
	<u>Flow</u>
Stream ID:	
Quantity (lb/hr):	39662.81
Composition:	
TDI	39662.81
Temperature (°F):	140
Pressure (psi):	2.01
Design Data:	
Material:	Carbon Steel
Holding Amount:	1 week
Volume:	90520 ft ³
Diameter:	88.43 ft
Length:	14.738 ft
Time Period:	168 hrs
Type	Open
Comments:	

Valve																					
Identification: Item Process Safety Valve Date: 4/4/2010 Item No. V-100 No. Required 1																					
Function: To separate the high pressure and low pressure processes																					
Operation: Continuous																					
Materials handled:																					
Stream ID: Quantity (lb/hr): Composition:	<table style="width: 100%; border-collapse: collapse;"> <thead> <tr> <th style="text-align: left; border-right: 1px solid black;"></th> <th style="text-align: left;"><u>Streams</u></th> </tr> </thead> <tbody> <tr> <td style="border-right: 1px solid black;"></td> <td>RX1LIQ --> TOSEP1</td> </tr> <tr> <td style="border-right: 1px solid black;"></td> <td>1001493</td> </tr> <tr> <td style="border-right: 1px solid black; text-align: right;">TDA</td> <td>5199.073</td> </tr> <tr> <td style="border-right: 1px solid black; text-align: right;">O2</td> <td>129.9303</td> </tr> <tr> <td style="border-right: 1px solid black; text-align: right;">CO</td> <td>7786.079</td> </tr> <tr> <td style="border-right: 1px solid black; text-align: right;">TDI</td> <td>39704.85</td> </tr> <tr> <td style="border-right: 1px solid black; text-align: right;">WATER</td> <td>8231.36</td> </tr> <tr> <td style="border-right: 1px solid black; text-align: right;">TDCARB</td> <td>17850.01</td> </tr> <tr> <td style="border-right: 1px solid black; text-align: right;">SOLVENT</td> <td>922591.7</td> </tr> </tbody> </table>		<u>Streams</u>		RX1LIQ --> TOSEP1		1001493	TDA	5199.073	O2	129.9303	CO	7786.079	TDI	39704.85	WATER	8231.36	TDCARB	17850.01	SOLVENT	922591.7
	<u>Streams</u>																				
	RX1LIQ --> TOSEP1																				
	1001493																				
TDA	5199.073																				
O2	129.9303																				
CO	7786.079																				
TDI	39704.85																				
WATER	8231.36																				
TDCARB	17850.01																				
SOLVENT	922591.7																				
Design Data:																					
Pressure Drop:	647.67 psi																				
Type:	Diaphragm																				
Comments: This valve is a safety measure to separate the high and low pressure reactor and separations processes.																					

Equipment Cost Summary

Table 15 on the following page shows all the equipment to be used in the TDI production process. The first column shows the unit numbers, as referenced on the detailed visio Process Flow Diagrams, followed by the purchase cost, which is adjusted for 2010 CE Index of 532.7⁹, bare module factor and the bare module cost of each unit.

The process machinery amounted to a bare module cost of \$67,616,401, with an additional amount of piping cost, calculated as 5% of the total equipment cost, of \$4,335,982, and estimated shipping cost¹⁰, based on industrial consultants' suggestion, of \$9,105,563. The total bare module cost, thus, amounts to \$81,057,946.

⁹ <http://www.che.com/pci/>

¹⁰ Shipping costs include those pertaining to process machineries, fabricated equipments, raw materials, TDI product, solid waste and waste water disposals.

Table 15: Equipment cost summary

Item No.	Name	Type	Purchase Cost	Bare Module Factor	Bare Module Cost
R-100 & R-101	Reactor 1	Fabricated Equipment	\$3,601,982	4.16	\$14,984,247
R-102 & R-103	Reactor 2	Fabricated Equipment	\$975,195	4.16	\$4,056,812
D-100	Distillation 1 column	Fabricated Equipment	\$358,784	4.16	\$1,492,542
D-100 Condenser	Col 1 condenser	Fabricated Equipment	\$732,226	3.17	\$2,321,158
HX-106	Col 1 hot oil system	Fabricated Equipment	\$121,330	3.17	\$384,618
D-100 Reboiler Pump	Col 1 reboiler pump and motor	Process Machinery	\$20,873	3.30	\$68,881
D-100 Accumulator	Col 1 reflux accumulator	Fabricated Equipment	\$42,323	3.05	\$129,086
D-100 Reflux Pump	Col 1 reflux pump and motor	Process Machinery	\$604,915	3.30	\$1,996,220
D-101	Distillation 2 column	Fabricated Equipment	\$2,081,824	4.16	\$8,660,388
D-101 Condenser	Col 2 condenser	Fabricated Equipment	\$664,903	3.17	\$2,107,742
HX-107	Col 2 hot oil system	Fabricated Equipment	\$18,467	3.17	\$58,540
D-101 Reboiler Pump	Col 2 reboiler pump and motor	Process Machinery	\$8,417	3.30	\$27,777
D-101 Accumulator	Col 2 reflux accumulator	Fabricated Equipment	\$27,045	3.05	\$82,487
D-101 Reflux Pump	Col 2 reflux pump and motor	Process Machinery	\$361,561	3.30	\$1,193,151
D-102	Distillation 3 column	Fabricated Equipment	\$105,262	4.16	\$437,889
D-102 Condenser	Col 3 condenser	Fabricated Equipment	\$200,000	1.00	\$200,000
D-102 Reboiler	Col 3 reboiler	Fabricated Equipment	\$34,077	3.17	\$108,024
D-102 Reboiler Pump	Col 3 reboiler pump and motor	Process Machinery	\$10,040	3.30	\$33,131
D-102 Accumulator	Col 3 reflux accumulator	Fabricated Equipment	\$16,220	3.05	\$49,472
D-102 Reflux Pump	Col 3 reflux pump and motor	Process Machinery	\$15,303	3.30	\$50,500
HX-100	Heat exchanger 1	Fabricated Equipment	\$15,022	3.17	\$47,618
HX-101	Heat exchanger 2	Fabricated Equipment	\$705,720	3.17	\$2,237,132
HX-102	Heat exchanger 3	Fabricated Equipment	\$34,099	3.17	\$108,095
HX-103	Heat exchanger 4	Fabricated Equipment	\$1,859,691	3.17	\$5,895,221
HX-104	Heat exchanger 5	Fabricated Equipment	\$178,472	3.17	\$565,756
HX-105	Heat exchanger 6	Fabricated Equipment	\$17,307	3.17	\$54,864
P-101	Pump and motor 1	Process Machinery	\$6,959	3.30	\$22,964
P-102	Pump and motor 2	Process Machinery	\$4,883	3.30	\$16,115
P-103	Pump and motor 3	Process Machinery	\$5,844	3.30	\$19,287
P-100	Pump and motor 4	Process Machinery	\$14,048	3.30	\$46,358
P-104	Pump and motor 5	Process Machinery	\$72,557	3.30	\$239,439
H-100	Heater 1	Fabricated Equipment	\$163,369	3.17	\$517,879
H-101	Heater 2	Fabricated Equipment	\$42,762	3.17	\$135,554
H-102	Heater 3	Fabricated Equipment	\$67,752	3.17	\$214,773
H-103	Heater 4	Fabricated Equipment	\$32,150	4.17	\$134,064
H-104	Heater 5	Fabricated Equipment	\$26,031	5.17	\$134,583
C-100	Cooler 1	Fabricated Equipment	\$27,789	3.17	\$88,092
C-102	Cooler 2	Fabricated Equipment	\$7,820	3.17	\$24,791
C-101	Cooler 3	Fabricated Equipment	\$16,770	3	\$53,159
F-100	Flash drum	Fabricated Equipment	\$49,837	4	\$207,321
ST-104	Storage tank 1	Storage	\$210,278	3	\$630,833
ST-105	Storage tank 2	Storage	\$111,805	3.0	\$335,414
ST-106	Storage tank 3	Storage	\$6,053	3	\$18,159
ST-107	Storage tank 4	Storage	\$302,715	3	\$938,416
ST-100	Storage tank 5	Storage	\$427,157	3.0	\$1,281,471
ST-101	Storage tank 6	Storage	\$3,689	3	\$11,068
ST-102	Storage tank 7	Storage	\$2,911,746	3	\$8,735,237
ST-103	Storage tank 8	Storage	\$2,153,358	3.0	\$6,460,075
	Piping, mixer, splitter	Spares	-	-	\$4,335,982
	Shipping	Other Equipment	-	-	\$9,105,563
	Total				\$81,057,946

Fixed-Capital Investment

Summary

Fixed-Capital Investment Summary

The fixed costs for the TDI production process mainly include equipment and ship costs, which have been discussed earlier in the previous section. There are also other costs which are assumed to be driven by the total bare module costs, direct permanent investment and depreciable capital. **Table 16** below shows the total permanent investment assumptions and the fixed-capital investment summary of the project.

Table 16: Total permanent investment input assumptions

Cost of Site Preparations:	5.00%	of Total Bare Module Costs
Cost of Service Facilities:	5.00%	of Total Bare Module Costs
Allocated Costs for utility plants and related facilities:	\$0	
Cost of Contingencies and Contractor Fees:	10.00%	of Direct Permanent Investment
Cost of Land:	2.00%	of Total Depreciable Capital
Cost of Royalties:	\$0	
Cost of Plant Start-Up:	4.00%	of Total Depreciable Capital

The cost of site preparations is assumed to be 5% of the total bare module costs. Since the project will be carried out at the Gulf Coast area, we believe that the site already has an existing integrated complex. That is, it is relatively unnecessary to undertake land surveys, surface clearing, excavating and landscaping. Therefore, the 5% cost allocation would be reasonable for this particular project.

The cost of service facilities includes utility lines, control rooms, laboratories for feed and product testing, maintenance shops, and other buildings. According to Seider, *et al*, the cost allocation of 5% would be adequate and relatively conservative. Furthermore, we did not allocate any cost for utility plants and related facilities since the utilities will be purchased from vendors.

Moreover, we allocate 7% of direct permanent investment to the cost of contingencies since the TDI production is a very typical industrial process. It does not involve tremendously hazardous materials and waste. Thus, we do not expect a high probability of contingency in the project. The other 3% cost allocation goes to the contractor fees, as suggested by Guthrie (1969)¹¹. The cost of land is also predicted as 2% of total depreciable capital. Finally, the cost of plant start-up should not be too expensive since our process does not involve highly novel technology, such that the process and equipment are well known to skilled operators. According to Seider, *et al*, the start-up cost may be as low as 2%, but to remain conservative with our assumptions, we chose 4% instead.

With all these assumptions, the calculated total fixed-cost investments to be incurred during the first year after the project start-date are tabulated in **Table 17**. It is shown that the total capital investment amounts to \$105,569,294.

¹¹ Seider, Seader, Lewin, Widagdo; Product and Process Design Principles

Table 17: Fixed-capital investment summary

Investment Summary		
<u>Bare Module Costs</u>		
Fabricated Equipment	\$	45,491,906
Process Machinery	\$	3,713,822
Spares	\$	4,335,982
Storage	\$	558,300
Other Equipment	\$	13,662,014
Catalysts	\$	14,546,797
Computers, Software, Etc.	\$	-
<u>Total Bare Module Costs:</u>	\$	<u>82,308,821</u>
<u>Direct Permanent Investment</u>		
Cost of Site Preparations:	\$	4,115,441
Cost of Service Facilities:	\$	4,115,441
Allocated Costs for utility plants and related facilities:	\$	-
<u>Direct Permanent Investment</u>	\$	<u>90,539,703</u>
<u>Total Depreciable Capital</u>		
Cost of Contingencies & Contractor Fees	\$	9,053,970
<u>Total Depreciable Capital</u>	\$	<u>99,593,673</u>
<u>Total Permanent Investment</u>		
Cost of Land:	\$	1,991,873
Cost of Royalties:	\$	-
Cost of Plant Start-Up:	\$	3,983,747
Total Permanent Investment – Unadjusted	\$	105,569,294
Site Factor		1.00
<u>Total Permanent Investment</u>	\$	<u>105,569,294</u>

Operating Cost and Economic Analysis

Economic Assumptions and Project Operations

Our economic analyses are based on the following tabulated assumptions and project chronology. The project will also yield TDI as its sole product.

Table 18: Project assumptions and operations summary

General Information						
		Process Title:	Phosgene-Free Route to Isocyanate			
		Product:	Toluene Diisocyanate (TDI)			
		Plant Site Location:	Gulf Coast			
		Site Factor:	1.00			
		Operating Hours per Year:	7920			
		Operating Days Per Year:	330			
		Operating Factor:	0.9041			
Product Information						
This Process will Yield						
			39,663	lb of Toluene Diisocyanate per hour		
			951,907	lb of Toluene Diisocyanate per day		
			314,129,466	lb of Toluene Diisocyanate per year		
Price			\$1.50¹²	/lb		
Chronology						
<u>Year</u>	<u>Action</u>	<u>Distribution of Permanent Investment</u>	<u>Production Capacity</u>	<u>Depreciation</u> 5 year MACRS	<u>Product Price</u>	
2010	Design		0.0%			
2011	Construction	100%	0.0%			
2012	Production	0%	45.0%	20.00%	\$1.50	
2013	Production	0%	67.5%	32.00%	\$1.52	
2014	Production	0%	90.0%	19.20%	\$1.55	
2015	Production		90.0%	11.52%	\$1.57	
2016	Production		90.0%	11.52%	\$1.59	
2017	Production		90.0%	5.76%	\$1.62	
2018	Production		90.0%		\$1.64	
2019	Production		90.0%		\$1.66	
2020	Production		90.0%		\$1.69	
2021	Production		90.0%		\$1.72	
2022	Production		90.0%		\$1.74	
2023	Production		90.0%		\$1.77	
2024	Production		90.0%		\$1.79	
2025	Production		90.0%		\$1.82	
2026	Production		90.0%		\$1.85	

¹² Given in the problem statement

Operating Cost Summary

Variable costs

The main components for our variable costs include the raw materials, utility costs, catalyst and promoter costs, and general expenses. The raw materials include TDA, oxygen, carbon monoxide, and TFE makeup. The prices of the first three materials are given in the problem statement. An estimate of \$12 per kilogram for the price of TFE was suggested by one of its suppliers, Halocarbon. Since we will be consuming approximately 1 million pounds of TFE, which makes up 20% of the current global TFE demand, we assumed a bulk price of \$9 per kilogram or \$4.08 per pound of TFE.

The utility prices are taken from Seider, *et al*, database, adjusted for 2010 \$. The cost breakdown for utilities is provided in Appendix 4.

The prices of the Co-tBu-Salen catalyst and the NaI promoter are relatively harder to obtain. One of the project consultants, Mr. Gary Sawyer of Lyondell Chemical Company, suggested that the catalyst price is mainly depends on the ligand used. Mr. Sawyer referred us to a comparable catalyst ligand, AcetylAcetone (AcAc) of which the price ranges from \$500 to \$6,000 per kilogram or \$227 to \$2,727 per pound. Thus, we made a base case assumption of \$3,000 per kilogram or \$1,364 per pound for the price of Co-tBu-Salen catalyst. The price of the NaI promoter is estimated from Mandev Enterprises, a wholesaler company from India.¹³ Finally, to be more conservative, we also took account for the possibilities that the catalyst and

¹³ Chatha, "Sodium Iodide"

the NaI being worn out and therefore need to be replaced. We assumed that the catalyst and the NaI have to be replaced every 9 months and 6 months respectively as a base case.

The general expenses comprise of selling and transfer expenses, research expenses, administrative expenses and management compensation. In an industry where technology advancement is very crucial, it is reasonable to assume that the direct and allocated research expenses should make up most of the costs. In our case, it makes up 41.6% of the total general expenses.

Below is the tabulated summary of the annual variable costs which will be incurred should we undertake the project.

Table 19: Summary of annual variable costs

Variable Cost Summary			
<u>Variable Costs at 100% Capacity:</u>			
<u>General Expenses</u>			
	Selling / Transfer Expenses:		\$
			14,135,826
	Direct Research:		\$
			22,617,322
	Allocated Research:	\$	2,355,971
	Administrative Expense:	\$	9,423,884
	Management Incentive Compensation:	\$	5,889,927
	Total General Expenses		\$
			54,422,930
<u>Raw Materials</u>	\$1.051077	per lb of Toluene Diisocyanate	\$330,174,135
<u>Byproducts</u>	\$0.000000	per lb of Toluene Diisocyanate	\$0
<u>Utilities</u>	\$0.048050	per lb of Toluene Diisocyanate	\$15,093,772
<u>Total Variable Costs</u>			\$
			<u>399,690,837</u>

From **Table 19** and based on the amount of TDI produced per year, it is found that \$1.27 variable costs will be incurred for every pound of TDI sold. Given the price of TDI of \$1.50 per pound, the project will have a profit margin of \$0.23 per pound of TDI sold.

The breakdown of the total variable costs can be seen in the following figure.

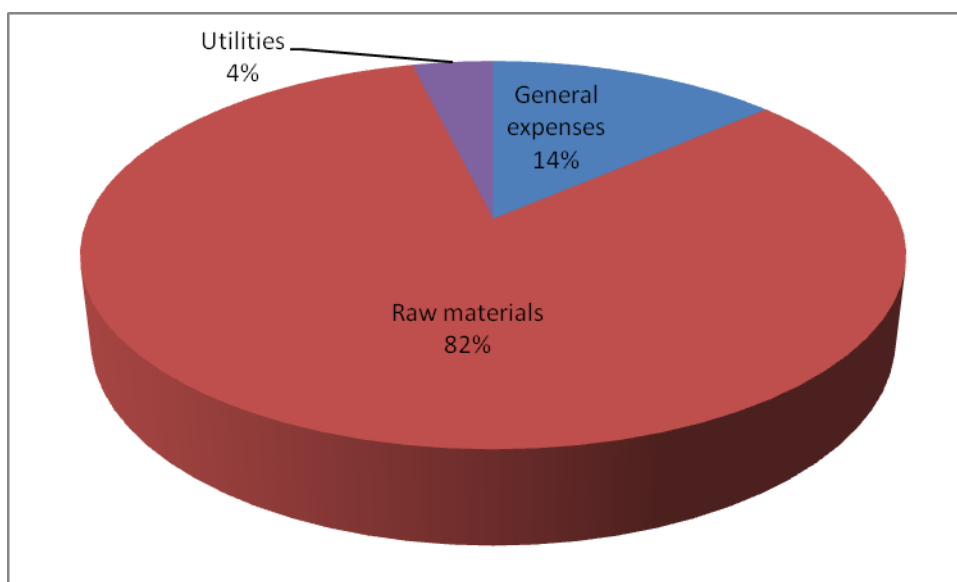

Figure 14. Breakdown of annual variable costs of TDI production

The breakdown shows that the raw materials make up most of the variable costs, followed by the general expenses, and utilities.

Fixed Costs

Fixed costs are independent of the amount of TDI produced annually. **Table 20** shows the summary of the annual fixed costs will be incurred for this project.

Table 20: Summary of annual fixed costs**Fixed Cost Summary****Operations**

Direct Wages and Benefits	\$	936,000
Direct Salaries and Benefits	\$	140,400
Operating Supplies and Services	\$	56,160
Technical Assistance to Manufacturing	\$	900,000
Control Laboratory	\$	975,000
Total Operations	\$	3,007,560

Maintenance

Wages and Benefits	\$	3,485,779
Salaries and Benefits	\$	871,445
Materials and Services	\$	3,485,779
Maintenance Overhead	\$	174,289
Total Maintenance	\$	8,017,291

Operating Overhead

General Plant Overhead:	\$	385,787
Mechanical Department Services:	\$	130,407
Employee Relations Department:	\$	320,584
Business Services:	\$	402,088
Total Operating Overhead	\$	1,238,866

Property Taxes and Insurance

Property Taxes and Insurance:	\$	1,991,873
-------------------------------	----	-----------

Other Annual Expenses

Rental Fees (Office and Laboratory Space):	\$	20,000
Licensing Fees:	\$	-
Miscellaneous:	\$	10,000
Total Other Annual Expenses	\$	30,000

Total Fixed Costs**\$ 14,285,590**

Comparing the fixed costs to the total variable costs, they are relatively low and therefore not a major factor in the profitability of the project.

Cash Flow and Profitability Analysis

Project Economics

The feasibility and the profitability of the TDI production process are analyzed based on several metrics, namely the net present value (NPV), internal rate of return (IRR), return on investment (ROI), and payback period. A discount rate of 15% is used to calculate the NPV, as recommended by Seider, *et al.* The economic analysis summary based on assumptions on the base, best, and worst case scenarios are tabulated below.

Table 21: Economic analysis summary

	Worst	Base	Best
Raw materials			
TDI price (\$/lb)	\$1.20	\$1.50	\$1.90
TFE price (\$/lb)	\$5.45	\$4.09	\$3.60
Catalyst price (\$/lb)	\$2,272.73	\$1,363.64	\$681.82
NaI price (\$/lb)	\$1.00	\$0.45	\$0.35
Process			
Reactor residence time (min)	180	60	20
Catalyst lifespan (month)	4	8	12
NaI lifespan (month)	4	8	12
Profitability Measures			
Net Present Value	(\$435,917,600)	\$20,658,400	\$392,139,600
ROI	-43.15%	12.03%	76.69%
IRR	-	18.05%	66.55%
Payback period (years)	-	3	0

Based on the results above, it is satisfying to see that on the base case assumption, the TDI production process is feasible and also profitable. In addition, the assumptions made in the base case scenario are conservative. The raw materials' prices have been discussed in the earlier section. With regards to the reactor residence time, our assumptions are solely based on

the knowledge from the patent contributed by Fernandez, *et al* (2008), which mentions that the reaction time ranges from 3 minutes to 3 hours. Due to the limited readily available kinetics data on our particular reaction processes, the information from the patent is deemed reasonable. The same argument applies to the usable lives of our catalyst and NaI promoter. Thus, rough assumptions were made after getting approval from the project consultants.

Table 22 summarizes the base case cash flow of the TDI production process.

Table 22: TDI production base case cash flow summary

Cash Flow Summary									
<u>Year</u>	<u>Sales</u>	<u>Capital Costs</u>	<u>Working Capital</u>	<u>Var Costs</u>	<u>Fixed Costs</u>	<u>Depreciation</u>	<u>Taxes</u>	<u>Net Earnings</u>	<u>Cash Flow</u>
2010	-	-	-	-	-	-	-	-	-
2011	-	(105,569,300)	(10,623,700)	-	-	-	-	-	(116,193,000)
2012	212,037,400	-	(5,311,800)	(202,121,557)	(14,285,590)	(19,918,735)	8,986,700	(15,301,800)	(694,900)
2013	322,826,900	-	(5,311,800)	(294,972,516)	(14,428,446)	(31,869,975)	6,824,300	(11,619,700)	14,938,400
2014	436,892,400	-	-	(389,660,281)	(14,572,731)	(19,121,985)	(5,008,900)	8,528,600	27,650,600
2015	443,445,800	-	-	(393,556,884)	(14,718,458)	(11,473,191)	(8,768,000)	14,929,300	26,402,500
2016	450,097,500	-	-	(397,492,453)	(14,865,643)	(11,473,191)	(9,718,500)	16,547,700	28,020,900
2017	456,849,000	-	-	(401,467,377)	(15,014,299)	(5,736,596)	(12,813,400)	21,817,300	27,553,900
2018	463,701,700	-	-	(405,482,051)	(15,164,442)	-	(15,930,400)	27,124,800	27,124,800
2019	470,657,200	-	-	(409,536,872)	(15,316,086)	-	(16,947,600)	28,856,700	28,856,700
2020	477,717,100	-	-	(413,632,240)	(15,469,247)	-	(17,987,800)	30,627,800	30,627,800
2021	484,882,900	-	-	(417,768,563)	(15,623,940)	-	(19,051,400)	32,438,900	32,438,900
2022	492,156,100	-	-	(421,946,248)	(15,780,179)	-	(20,139,000)	34,290,700	34,290,700
2023	499,538,400	-	-	(426,165,711)	(15,937,981)	-	(21,250,900)	36,183,900	36,183,900
2024	507,031,500	-	-	(430,427,368)	(16,097,361)	-	(22,387,500)	38,119,300	38,119,300
2025	514,637,000	-	-	(434,731,642)	(16,258,334)	-	(23,549,400)	40,097,600	40,097,600
2026	522,356,500	-	21,247,300	(439,078,958)	(16,420,918)	-	(24,737,000)	42,119,700	63,367,000

Sensitivity Analysis

As the range of the profitability has been determined, more detailed economic analyses are carried out to ensure the reliability of our recommendation. After careful analyses on the key drivers of the TDI production process, there are several items through which our recommended decision on the project may or may not change, namely:

- TDI product price
- Co-tBu-Salen catalyst price and lifespan
- Reactor residence time

Sensitivity of NPV towards TDI Product Price and Product Inflation Rate

Table 23: Sensitivity analysis on NPV towards TDI price and its inflation rate

		Product Price Inflation Rate						
		0.0%	0.5%	1.0%	1.5%	2.0%	2.5%	3.0%
Product Price	\$0.75	(\$510,959,000)	(\$579,394,700)	(\$563,175,500)	(\$546,378,700)	(\$528,981,200)	(\$510,959,000)	(\$492,287,000)
	\$0.90	(\$390,467,600)	(\$472,590,500)	(\$453,127,400)	(\$432,971,300)	(\$412,094,300)	(\$390,467,600)	(\$368,061,200)
	\$1.05	(\$269,976,300)	(\$365,786,300)	(\$343,079,400)	(\$319,563,800)	(\$295,207,400)	(\$269,976,300)	(\$243,835,500)
	\$1.20	(\$149,484,900)	(\$258,982,100)	(\$233,031,300)	(\$206,156,400)	(\$178,320,500)	(\$149,484,900)	(\$119,609,700)
	\$1.35	(\$28,993,600)	(\$152,177,900)	(\$122,983,300)	(\$92,749,000)	(\$61,433,500)	(\$28,993,600)	\$4,616,000
	\$1.50	\$91,497,800	(\$45,373,700)	(\$12,935,200)	\$20,658,400	\$55,453,400	\$91,497,800	\$128,841,800
	\$1.65	\$211,989,100	\$61,430,500	\$97,112,900	\$134,065,800	\$172,340,300	\$211,989,100	\$253,067,500
	\$1.80	\$332,480,500	\$168,234,700	\$207,160,900	\$247,473,300	\$289,227,200	\$332,480,500	\$377,293,300
	\$1.95	\$452,971,800	\$275,038,900	\$317,209,000	\$360,880,700	\$406,114,100	\$452,971,800	\$501,519,000
	\$2.10	\$573,463,200	\$381,843,100	\$427,257,000	\$474,288,100	\$523,001,000	\$573,463,200	\$625,744,800
	\$2.25	\$693,954,600	\$488,647,300	\$537,305,100	\$587,695,500	\$639,887,900	\$693,954,600	\$749,970,500

The table above shows that the positive NPV we have currently is very sensitive towards the future product inflation rate and the TDI competitive price. If the global TDI demand is not sustainable or keeps in decreasing trend, it is natural that the TDI product price may become cheaper. In addition, the risk of deflation may also become more important. If this is the case, then the project may not look attractive since NPV starts becoming negative right away.

However, it is expected that the current decreasing trend in global TDI demand will rebound soon after the economy recovers. In addition, TDI is one of the most important materials in automotive and transport industries. These industries are growing really fast especially in developing countries. For example, its demand in the giant economic driver, China, has been showing promising trend. Even in the more developed countries like the US, transportation and automotive industries are amongst the most sustainable. Thus, it is unlikely that the TDI price will drop in the future, not to mention any great possibility of deflation.

Sensitivity of NPV towards Catalyst Price and its Lifespan

Table 24: Sensitivity analysis on NPV towards Co-tBu-Salen catalyst price and lifespan

		Co-tBu-Salen Replacement Period (month)						
		2	4	6	8	10	12	14
Co-tBu-Salen Price per lb	\$600	(\$23,848,900)	\$41,862,900	\$63,766,800	\$74,718,800	\$81,290,000	\$85,670,800	\$88,799,900
	\$650	(\$35,602,800)	\$35,584,900	\$59,314,200	\$71,178,800	\$78,297,600	\$83,043,500	\$86,433,400
	\$850	(\$82,618,600)	\$10,473,100	\$41,503,600	\$57,018,900	\$66,328,100	\$72,534,200	\$76,967,200
	\$1,050	(\$129,634,400)	(\$14,638,800)	\$23,693,100	\$42,859,000	\$54,358,600	\$62,025,000	\$67,501,000
	\$1,250	(\$176,650,300)	(\$39,750,700)	\$5,882,500	\$28,699,100	\$42,389,100	\$51,515,700	\$58,034,800
	\$1,364	(\$176,650,300)	(\$39,750,700)	\$5,882,500	\$28,699,100	\$42,389,100	\$51,515,700	\$58,034,800
	\$1,450	(\$223,666,100)	(\$64,862,500)	(\$11,928,000)	\$14,539,200	\$30,419,600	\$41,006,500	\$48,568,600
	\$1,650	(\$270,681,900)	(\$89,974,400)	(\$29,738,600)	\$379,300	\$18,450,100	\$30,497,200	\$39,102,300
	\$1,850	(\$317,697,700)	(\$115,086,300)	(\$47,549,100)	(\$13,780,600)	\$6,480,600	\$19,988,000	\$29,636,100
	\$2,050	(\$364,713,500)	(\$140,198,100)	(\$65,359,700)	(\$27,940,500)	(\$5,489,000)	\$9,478,700	\$20,169,900
	\$2,250	(\$411,729,300)	(\$165,310,000)	(\$83,170,300)	(\$42,100,400)	(\$17,458,500)	(\$1,030,500)	\$10,703,700

The sensitivity table above shows a very wide range of the possible catalyst prices and its lifespan. However, we are more interested in observing the data around our base case, which are highlighted in blue. In this region, there is only one negative NPV data point, i.e. when the catalyst lifespan is 2 months shorter than that in our base case and the price is about \$100 higher. Although we believe that our assumptions are fairly conservative, we would still be uncertain since the profitability really depends on the specific properties of this particular catalyst. As per current understanding, the project is recommended only if the catalyst's lifespan is at least 6 months with a price of less than \$1,450 per lb. Further research on Co-tBu-Salen is strongly recommended in order to come up with solid project recommendation.

Sensitivity of NPV towards Reactor Residence Time**Table 25:** Sensitivity analysis on NPV towards reactor residence time

NPV	Reactor residence time (min)								
	20	40	60	80	100	120	140	160	180
	\$38,155,300	\$29,295,700	\$20,653,700	\$12,122,000	\$3,660,000	(\$4,752,900)	(\$13,128,600)	(\$21,475,100)	(\$29,797,600)

Same as the previous section, it is rather difficult to decide whether the assumptions made are valid when the kinetics and detailed reaction data are not available. However, from the current knowledge that we have, the project is still profitable and thus should be undertaken as long as the reaction time does not reach two hours. Again, further research on the reaction kinetics needs to be carried out thoroughly.

Other Economic Uncertainties

There are quite a number of economic uncertainties that need to be considered in this project.

Raw Materials and TDI Product

As mentioned before, the price of the Co-tBu-Salen catalyst and any information pertaining its kinetics, lifespan, and effectiveness in supporting the TDI formation reaction are not readily available. In addition, the global TDI demand is currently fluctuating in various regions. Thus, further economic research has to be done before deciding whether it is truly worthwhile to start producing TDI through the phosgene-free route.

Production Process

There are also some uncertainties that need to be account for during the production process. Firstly, it is assumed that there are no polymeric materials formed during the TDI production process even when the process machineries operate at high pressure. The polymeric materials formation will reduce the total amount of TDI produced. Therefore, there are possibilities that we need to account for the equipment to remove polymeric materials, i.e. the whitefilm evaporator. Although we already have a 5% buffer on the amount of the TDI produced per year, the uncertainties still exist and we do not have 100% confidence in how much polymeric material may be formed.

In addition, we also assumed that any solid waste and wastewater produced in the process are within the regulatory limits. This implies that we may need to account for waste management costs that might possibly come up.

Other Economic Uncertainties

Major economic uncertainties include changes in macroeconomic growth, changes in raw material and product prices, government regulations, and supply- and demand- sides technological advances related to TDI production process

Other Issues and Considerations

Other Issues and Considerations

Environmental Concerns:

In keeping up with EPA guidelines, the wastewater produced as a byproduct in the reaction will be distilled to as high a purity as possible to prevent environmental contamination. The EPA has produced guidelines for the treatment, storage, and transportation of industrial wastewater. The federal government regulates the dumping of hazardous industrial wastewater by requiring companies to apply for dumping permits. These permits are only issued if the company wishing to dump can prove that their wastewater meets federal standards of composition and that their waste will not contaminate the drinking water supply or surface water in which there is a high risk for human contact. The EPA also regulates the storage of wastewater. Wastewater storage tanks must be placed on special platforms or in specially designated storage facilities. They must also be monitored continuously for cracking and leaks. The transportation of wastewater to offsite water treatment/water disposal sites is also highly regulated by federal law¹⁴. In all, these precautions are all important in preventing accidental run off or leakage of industrial waste into the environment at large. The collection and removal of the heavy sludge from the first distillation column are similarly regulated.

As one of our main project goals, an environmentally friendly process is highly important to plant sustainability. In this regard, we plan to follow all federal and regional waste

¹⁴ EPA, "EMS Handbook for Wastewater Utilities"

storage and removal guidelines (EPA, OSHA, etc.) to prevent any of our hazardous materials from entering and maliciously impacting the environment.

Plant Safety Concerns:

A primary concern in the design of this process is plant safety. Although phosgene is by far the most hazardous component of alternative TDI production process designs, there are still safety hazards in this design that need to be carefully monitored. The safety risk of greatest concern is the ratio gaseous O₂ to CO where both coexist in a gas phase. The areas of the process to which this is relevant include the vapor phase in the two reactors and within the piping that connects the vapor effluent streams to and from these reactors. The explosion risk concentration range of CO in O₂ at 392 F and 14.7 psi goes from 14.2% to 95.3%. It is therefore necessary to keep a high ratio of CO:O₂ in the gas phase; a ratio of at least 19:1 is recommended. The process is designed not to come near the explosive risk range, however it cannot be determined that all of the equipment will consistently operate to maintain the concentrations at any given time. That is, although the average steady state may be well within safety standards, deviations in operability may pose a threat. To account for this, there is one control system for each reactor set in place to maintain this operation condition. The feedback controller adjusts the CO and O₂ feed valves in response to the relative concentrations of CO and O₂ in the reactor vapors. It is important to note here that a full scale control analysis for this process is not in the scope of this project.

The high pressure reaction system poses another safety hazard. Pressure buildups and leaks within the reactors and piping can lead to serious problems. Control valves should be

installed as necessary at various stages throughout the process to monitor and manage unexpected pressure-related issues. Control mechanisms measuring the oxygen concentration inside the columns are extremely necessary because they operate at pressures lower than atmospheric pressure. This means that if there is a leak in a column, air could enter the vessel increasing the oxygen concentration in the vapor phase which could bring the vapor composition into the explosion envelope. Obviously, this scenario could be extremely dangerous.

As mentioned previously, the reaction section and first distillation column must be coated in Hastelloy to prevent equipment corrosion. The reaction promoter, NaI, is highly corrosive and can cause substantial damage to the equipment and piping without the coat of highly corrosion resistant alloy. The Hastelloy coat significantly increases the equipment costs but is absolutely necessary to prevent more costly damage. At this time, there is not enough information about the role and properties of NaI within this process to develop control measures to ensure that all of the NaI is contained within the designated equipment loops; however that is a necessary course of investigation in the later stages of process development.

As far as chemical handling, the main materials that will be present in the process pose moderate health risks. TFE is harmful if inhaled, absorbed through the skin, in contact with the eyes or ingested (TFE MSDS). Workers must take care to avoid inhaling TFE fumes as this has been proven to cause serious health problems over prolonged exposure. Most of the TFE handling will be during the initial charge and recharges after downtime, since the solvent is not consumed and is preserved to a high degree during separations.

TDA is highly poisonous and may be fatal if swallowed, inhaled or absorbed through the skin (TDA MSDS). As with TFE, direct contact with TDA should be minimal as its only contact point to the system is typically a steady feed. The amount of TDA used in our process must be reported to the EPA because it exceeds the 10lb “reportable quantity” limit¹⁵. The handling and disposal of quantities exceeding this limit falls under a regulation called Resource Conservation and Recovery Act (RCRA). Based on RCRA criteria, materials contaminated with TDA are considered “hazardous waste” upon disposal. For this reason we will need to follow certain storage, handling and disposal restrictions as outlined in the RCRA (TDA MSDS).

TDI is hazardous if ingested. TDI is also classified as an eye and skin irritant with a risk of death if severe exposure occurs. Another safety concern arises in the storage of TDI. TDI is a highly flammable substance at high temperature, and it must be stored in locations far away from heat and any area in which it can be ignited (TDI MSDS). The amount of TDI produced in our process must be reported to the EPA because it exceeds the 100lb “reportable quantity” limit. Finally, a monitoring system must be put in place to test whether TDI stays below the OSHA maximum of 0.02ppm in air¹⁵.

NaI, which should be present in much lower concentrations than the other components, is an irritant and can cause complications if ingested, inhaled or absorbed by the skin (NaI MSDS). However, this chemical will also be almost entirely contained within the system at all times.

Oxygen gas is most hazardous due to combustion risk.

¹⁵ Barbalace, Environmental Chemistry

Carbon monoxide is highly toxic and particularly dangerous because it is hard to detect. Monitors will be installed to prevent unknown exposure. For safety reasons, it is a priority that both of these gases be handled very carefully.

Startup

The amount of solvent required to charge the reactor will need to be supplied in very high volume. In fact, the amount of TFE required for this process will consume approximately 15-20% of the current world's supply. Because this requires such high volume of chemical purchase, transport, and storage, the predicted costs for TFE supply are only approximate estimates which are subject to change based on the method of transport, the equipment that may be necessary for delivery of the solvent to the system and potential price shifts corresponding to the significant increase in global demand.

Another exception during startup is the initial charge of CO and O₂ gases in the reactor. The initial charge must be conducted very carefully, since the explosion risk is active while the system tries to equilibrate. To avoid this, the system will be initially charged to nearly full pressure with CO, followed by the TFE and NaI charge and a small stream of O₂ will be bubbled up through the solution until the mole ratio of CO to O₂ is about 120:1 (close to the steady state ratio of (118.7:1)). When operation begins, the CO and O₂ fresh feeds will enter the reactor at about a 2:1 ratio, and should be maintained safely since almost all of the fresh gas will be dissolved into the solvent.

Conclusions and Recommendations

Conclusions and Recommendations

Based on the patent titled “One-Step Catalytic Process for the Synthesis of Isocyanates” contributed by Fernandez, *et al* in 2008, and several assumptions on relevant reaction kinetics, an economically viable and technically feasible phosgene-free TDI production process has been designed. The design requires two reactors in order to consume as much reactants as possible in each production cycle. This is particularly important especially because of the very expensive TFE solvent of which currently we need about $\frac{1}{4}$ of the total world demand. As the TDI has been formed, the product mix is passed through the distillation separation trains. The main focus in the first distillation column is to isolate the NaI promoter since it is corrosive and requires expensive hastelloy coating on every pipe and process units it flows through. The second distillation column separates all the isocyanates at the bottom of the stage. The last distillation column then isolates the wastewater. Unreacted materials, including the solvent, the catalyst and the NaI promoter are recycled back to the reactors continuously.

Looking at the base case scenario results, it is apparent that our project results in a positive NPV of \$20,653,700, with an ROI of 12.03% and an IRR of 18.05%. The result is satisfying remembering that the assumptions we made are conservative. However, the feasibility also strongly depends on several moving parts like future economic outlook, which will affect global TDI demand and thus its price, and other raw materials’ costs

Aside from the inherent economic risks like the health of our company, which is assumed to be perfectly operational with no debt maturing in visibility projection, the actual reaction process kinetics are very crucial piece of information. The amount of time required for

the reaction to complete will determine the size of our reactor and thus the investment costs. The same applies to the important knowledge we need regarding the lifespan of the catalyst, which will affect the variable costs every year.

Other risks are related to government regulatory limits on the atmospheric concentrations of our chemicals throughout the production process. Based on the calculations we get from the Aspen simulation model, the chemicals involved in the TDI production process are not too hazardous and they do not exceed the amounts described in the government regulations. However, we are still need to be ready should any unexpected circumstances arise.

Since the NPV of the base case scenario is positive and remembering the conservative assumptions we made along with a reasonable payback period of 3 years, we recommend undertaking this project. Not only the project looks promising, the fact that it is a novel process that is phosgene-free makes it even more attractive.

Even so, we still strongly recommend further detailed research on the reaction kinetics, the catalyst and the promoter characteristics, as well as global economic research on TDI. Further research needs to be conducted on the kinetics of the process, the exact role of the catalyst and the promoter in the reactions and their effects on the TDI yield, and of course the life span of the three components. The information would enable us to look for comparable catalysts, solvents and promoters of similar roles as those we are currently using, and thus find cheaper alternatives to drive down investment and variable costs each year.

In addition, it would be worthwhile to do more research on various other ways to produce TDI in the current market. It would be great if we can reduce the number of distillation we use. One way to do this may be by having a solid support to hold the NaI in one place

together with the catalyst beds. Therefore, we would not need to isolate NaI and transfer it to the recycle stream back to the reactors, driving down hastelloy coating cost and more importantly taking away one of the distillation columns used to isolate NaI. In addition, further research needs to be done on other means of separation process which is crucial in this project.

Thus, until we are clear about all the uncertainties and the underlying assumptions that we made, it is very difficult to be properly confident about the feasibility of the TDI production through a free phosgene-route. Although we are still positive that TDI production process described in this report is viable, looking at the nature of complexity of the project, which is actually relatively conventional and not so difficult to setup by experienced contractors at the Gulf Coast.

Acknowledgments

Acknowledgments:

Throughout the design process we have been provided with an abundant amount of help from our faculty advisor, professors, industrial consultants, and industrial contacts. Without their time, energy, and effort, this report would not have been. For this reason we would like to thank Dr. Daeyeon Lee, Professor Leonard Fabiano, Dr. Warren Seider, Mr. Bruce Vrana, Mr. Steve Tieri, Dr. E. Robert Becker, and Mr. Gary Sawyer for their help in our overall process design, ASPEN modeling, and for help estimating prices for our exotic materials. Professor Fabiano, with ample experience in real life TDI production processes, was especially helpful in helping us modify, optimize, and troubleshoot our ASPEN flow sheet so that the specs met the patent and real world standards as closely as possible. He spent several hours of his own time with us in weekly meeting and at home in an effort to help us reach our goal of creating an environmentally-friendly process. Additionally, as the creator of the problem statement, Mr. Bruce Vrana, DuPont, was extremely helpful in guiding us through the intricacies of the phosgene-free process for creating TDI from TDA. He also helped us to develop adequate assumptions for process parameters and price estimates which were paramount in the completion of this report.

In addition to our professors and consultants, we would like to thank the sales representatives at for their price estimates and availability for industrial scale TFE which was used as the basis for pricing the highly expensive solvent used in the process. The

representatives also provided us with estimates of the prices of competitive solvents which ultimately led to our selection of TFE as our solvent.

List of Figures and Tables

List of Figures and Tables

Figure 1: Innovation Map

Figure 2: Major producers' TDI production capacity

Figure 3: Moderately increasing TDI demand in USA

Figure 4: Option 1 -- single three-loop pass reactor detailed process flow sheet

Figure 5: Option 2 -- Two-reactor system detailed process flow sheet

Figure 6: Three-loop pass reactor system

Figure 7: Distillation separation complex

Figure 8: Process Block Diagram

Figure 9: Process Flow Diagram

Figure 10: Reactor-system section

Figure 11: Section 2 - Separation Process

Figure 12: Block flow diagram for the TDI production

Figure 13: Detailed ASPEN Plus flow sheet of TDI production

Figure 14: Breakdown of annual variable costs of TDI production

Table 1: The required ratio of raw materials per pound of TDI produced

Table 2: Summary of incremental cost saving of reactor system in option 2

Table 3: Stream information for the Reactors Block

Table 4: Stream information for the Separations Block

Table 5: Process Material Balance

Table 6: Streams that need to be heated or cooled

Table 7: Streams in separation block that need to be heated or cooled

Table 8: Energy saved per stream

Table 9: Total energy savings and % energy

Table 10: Possible heat duty savings summary by using two parallel distillation columns in place of D-100

Table 11: Utility cost of cooling water

Table 12: Utility cost of steam

Table 13: Utility cost of fuel oil

Table 14: Utility cost of landfill

Table 15: Equipment cost summary

Table 16: Total permanent investment input assumptions

Table 17: Fixed-capital investment summary

Table 18: Project assumptions and operations summary

Table 19: Summary of annual variable costs

Table 20: Summary of annual fixed costs

Table 21: Economic analysis summary

Table 22: TDI production base case cash flow summary

Table 23: Sensitivity analysis on NPV towards TDI price and its inflation rate

Table 24: Sensitivity analysis on NPV towards Co-tBu-Salen catalyst price and lifespan

Table 25: Sensitivity analysis on NPV towards reactor residence time

Table 26: 2010 Chemical Engineering Cost Indices

Table 27: Catalyst pricing calculations

Table 28: Solvent (TFE) and promoter (NaI) cost calculations

Table 29: Utility costs for relevant process units

Bibliography

Bibliography

EMS Handbook for Wastewater Utilities. Rep. Environmental Protection Agency (EPA). Web. 3 Apr.

2010.

Alloys: Hastelloy. Rep. Espi-metals.com. Web. 29 Mar. 2010.

Analysis and Forecast of China TDI Market 2009-2010. ReportLinker. Web. 15 Mar. 2010.

<<http://www.reportlinker.com/p0166490/Analysis-and-Forecast-of-China-TDI-Market-2009-2010.html?request=news>>.

Barbalace, Kenneth. Chemical Database - Toluenediamine. EnvironmentalChemistry.com. 1995 -

2010. Accessed on-line: 4/3/2010

<http://EnvironmentalChemistry.com/yogi/chemicals/cn/Toluenediamine.html>.

Barbalace, Kenneth. Chemical Database - Toluene diisocyanate. EnvironmentalChemistry.com.

1995 - 2010. Accessed on-line: 4/3/2010

<http://EnvironmentalChemistry.com/yogi/chemicals/cn/Toluene%20diisocyanate.html>

"CDC | Facts About Phosgene." *CDC Emergency Preparedness & Response Site*. Centers for Disease

Control and Prevention, 7 Feb. 2005. Web. 28 Jan. 2010.

<<http://www.bt.cdc.gov/agent/phosgene/basics/facts.asp>>.

"CDC - NIOSH Pocket Guide to Chemical Hazards - Phosgene." *NIOSH Pocket Guide to Chemical Hazards: Phosgene*. Centers for Disease Control and Prevention, Sept. 2005. Web. 28 Jan. 2010. <<http://www.cdc.gov/niosh/npg/npgd0504.html>>.

Cesar, Marcos N. "Integrated Production of Toluene Diisocyanate from Toluene." *SRI Consulting*. Oct. 2009. Web. 18 Mar. 2010. <http://www.sriconsulting.com/PEP/Reports/Phase_2009/RW2009-3/>.

Chatha, Devindersingh. "Sodium Iodide." *Alibaba.com*. Web. 20 Mar. 2010.

Chronic Toxicity Summary: 2,4- AND 2,6-TOLUENE DIISOCYANATE. Rep. Office of Environmental Health Hazard Assessment. Dec. 2000. Web. 2 Feb. 2010.

Developments in Toluene Diisocyanate (TDI) Process Technology. Rep. Nexant, Inc., Oct. 2008. Web. 02 Feb. 2010.

Hassan, Abbas, Ebrahim Bagherzadeh, Rayford G. Anthony, Gregory Borsinger, and Aziz Hassan. SYSTEM AND PROCESS FOR PRODUCTION OF TOLUENE DIISOCYANATE Read More: [Http://www.faqs.org/patents/app/20090005589#ixzz0kzblYy32](http://www.faqs.org/patents/app/20090005589#ixzz0kzblYy32). H R D CORPORATION, assignee. Patent 560338. Print.

"Hazard Analysis." *Wikipedia, the Free Encyclopedia*. Web. 05 Apr. 2010. <http://en.wikipedia.org/wiki/Hazard_analysis#Further_reading>.

"Hazard and Operability Study." *Wikipedia, the Free Encyclopedia*. Web. 06 Apr. 2010. <http://en.wikipedia.org/wiki/Hazard_and_operability_study#Further_reading>.

Harrison, Karl. "Phosgene @ 3DChem.com." *Phosgene, What Is Phosgene? About Its Science, Chemistry and Structure*. 3DChem.com, Sept. 2007. Web. 28 Jan. 2010

MSDS obtained from an Internet search

TDI; MSDS No. T1264; Sciencelab.com Inc. Houston, TX.

<<http://www.sciencelab.com/msds.php?msdsId=9925283>>

"MSDS :: Sodium Iodide." *Science Stuff :: Educational Science Supplies, Toys, Games and Kits*. Web. 06 Apr. 2010. <<http://www.sciencestuff.com/msds/C2656.html>>.

Seider, W. D., Seader, J., Lewin, D. R., & Widagdo, S. (2009). *Product and Process Design Principles*, Third Edition. New York: John Wiley & Sons, Inc.

Serrano Fernandez, Francisco Luis, Beatriz Almena Munoz, Ana Padilla Polo, Arana Orejon Alvarez, Carmen Claver Cabrero, Sergio Castillon Miranda, Pilar Salagre Carnero, and Ali Aghmiz. One-step Catalytic Process for the Synthesis of Isocyanates. REPSOL-YPF,S.A., assignee. Patent 7423171. 9 Sept. 2008.

Subramaniam, R. Shankar. "How to Design a Shell-and-Tube Heat Exchanger." Web. 20 Mar. 2010. <<http://web2.clarkson.edu/projects/subramanian/ch302/notes/designshelltube.pdf>>.

The Benefits of Chlorine Chemistry in Polyurethanes. Rep. Global Insight, Dec. 2006. Web. 22 Mar. 2010.

"Toluene Di-isocyanate (TDI) CAS No: 584-84-9." *ICIS.com*. Web. 2 Feb. 2010.

<<http://www.icis.com/V2/chemicals/9076539/toluene-diisocyanate.html>>.

Toluene Diisocyanate: Handling Guide. Rep. Perstorp -- Winning Formulas. Web. 20 Apr. 2010.

"Toluene Di-isocyanate (TDI) Prices and Pricing Information." *Chemical Industry News & Intelligence* / *ICIS.com*. Web. 13 Mar. 2010. <<http://www.icis.com/V2/Chemicals/9076540/toluene-diisocyanate/pricing.html>>.

"Toluene Di-isocyanate (TDI) Uses and Outlook." *Chemical Industry News & Intelligence* / *ICIS.com*. Web. 13 Mar. 2010. <<http://www.icis.com/V2/Chemicals/9076541/toluene-diisocyanate/uses.html>>.

"Universal Industrial Gases, Inc. ... MSDS Gaseous Oxygen - O2." *Universal Industrial Gases, Inc. - UIG Gas & Liquid Plants Supplier - UCG Onsite Gas Supplier / Producer of Nitrogen & Oxygen - Air Separation Plant Supplier - New Cryogenic Nitrogen Plants, Oxygen Plants, Air Separation Plants and Liquefiers Manufacturer; On-site N2 and O2 Gas Producer (Universal Cryo Gas)*. Web. 06 Apr. 2010. <http://www.uigi.com/MSDS_gaseous_O2.html>.

Zhiyang, Hou. "Stable Price of TDI in 2009.(Organics) - Entrepreneur.com." *Entrepreneur*. 16 Apr. 2009. Web. 13 Mar. 2010. <<http://www.entrepreneur.com/tradejournals/article/198473067.html>>.

Appendix

Appendix 1: Equipment Sizing and Costing Sample Calculations

Appendix 1A: Sample Calculation for Distillation Column Size and Price

Modeled as vertical vessel; Example: Distillation column D-100

Column sizing

From the Aspen stream report:

Distillate rate, D (lb/hr): 978460.81; Average MW: 96.03; Reflux ratio, R: 2.4

Liquid rate, L (lb/hr) = D x R = 2348305.94

Vapor rate, V (lb/hr) = D x L = 3326766.75

Assuming ideal gas:

R (ft³.psi/R.lbmol): 10.73159; T (R): 662.72; Pressure (psi): 2.2

$$\text{Vapor density } \left(\frac{\text{lb}}{\text{ft}^3} \right) = \frac{\text{MW} \times P}{RT} = 0.0297$$

Flooding velocity, U_f (ft/s):

$$F_{st} = \left(\frac{\text{surface tension}}{20} \right)^{0.5} ; \text{ Assume: } F_{st} = 1 \text{ (Recommended by Seider, et al)}$$

$F_f = 1$; non-foaming system

$F_{HA} = 1$; sieve trays with $A_h/A_A = 0.1$

$$F_{lg} = \frac{L}{V} \left(\frac{\rho_v}{\rho_L} \right)^{0.5} = 0.0122 ; \rho_L = 100 \frac{\text{lb}}{\text{ft}^3}$$

Plate spacing = 11in, $C_{sb} = 0.28$ (From 19.4 p. 505)

$$U_f = C_{SB} F_{ST} F_f F_{HA} \left(\frac{\rho_L - \rho_v}{\rho_v} \right)^{0.5} = 10.24 \frac{\text{ft}}{\text{s}}$$

$$U = 0.83 \times 16.24 = 13.81 \frac{\text{ft}}{\text{s}}$$

Column size:

From Aspen report:

Column diameter, $D_t = 9.57$; Number of trays, $N_t = 20$

Column height, $H \text{ (ft)} = 4 + 2(N_t - 1) + 10 = 52$

Column Purchase Price

$$C_p = F_m C_v + C_{pl} + C_t$$

C_v (Cost of vertical tower):

Weight of the shell:

Material: Carbon steel with $\frac{1}{4}$ in coating of Hastelloy

Corrosion allowance (in) = 0.25 (recommended by Seider *et al*)

Minimum wall thickness (in) = 0.5 (recommended by Seider *et al*)

$$t_s \text{ (in)} = 0.25 + 0.5 = 0.75$$

F_m : $F_{m, \text{carbon steel}} = 1$; $F_{m, \text{hastelloy}} = 2.95$

$$F_{m, \text{weighted}} = 0.75 F_{m, \text{carbon steel}} + 0.25 F_{m, \text{hastelloy}} = 1.4875$$

Density of material: $\rho_{\text{carbon steel}} = 490 \text{ lb/ft}^3$; $\rho_{\text{hastelloy}} = 554.98 \text{ lb/ft}^3$

$$\rho_{\text{material}} = 0.75 \rho_{m, \text{carbon steel}} + 0.25 \rho_{m, \text{hastelloy}} = 506.25 \text{ lb/ft}^3$$

$$W = \pi(D_t + t_s)(L + 0.8D_t)t_s\rho_m = 36857.71 \text{ lb}$$

$$C_v = \text{EXP}(7.2756 + 0.18255 \cdot (\text{LN}(W)) + 0.02297 \cdot (\text{LN}(W))^2) = \$167,296$$

C_{pl} (Cost of platforms and ladders):

$$C_{pl} = 300.9 \times (D_t^{0.63316}) \times L^{0.80161} = \$29,849$$

C_t (Cost of trays):

Type – sieve trays; Type factor, $F_{TT} = 1$; $F_{TM} = 1.4875$; Number factor, $F_{NT} = 1$ (for trays ≥ 20)

$$C_{bt}(\text{base cost}) = 369 \times \text{EXP}(0.1739D_t) = \$1,947$$

$$C_t = C_{bt}F_{TT}F_{Nt}F_{tm}N_t = \$57,932$$

$$C_p = F_m C_v + C_{pl} + C_t = \$336,634 ; \text{ Adjusted } C_p = \$336,634 \times \frac{532.9}{500} = \$358,784$$

Bare module factor (F_m) = 4.16,

$$C_{bm} = F_m \times \text{adjusted } C_p = \$1,492,542$$

Appendix 1B: Sample Calculation for Cooler and Condenser

Modeled as shell&tube heat exchanger (fixed head); Carbon steel shell; 20ft long

Example: Distillation condenser D-100

Condenser sizing:

Heat duty, Q (Btu/hr) = -651,276,420

Hot stream temp in (F)	36.8
Hot stream temp out (F)	34.98
Cold stream temp in (F)	90
Cold stream temp out (F)	120

$$\Delta T_{lm} = \frac{(T_{Hot,in} - T_{Cold,out}) - (T_{Hot,out} - T_{Cold,in})}{\left(\frac{\ln(T_{Hot,in} - T_{Cold,out})}{(T_{Hot,out} - T_{Cold,in})} \right)} = -68.14$$

U (Btu/hr-ft²-F) = 100

$$\text{Heat exchange surface area, A(ft}^2\text{)} = \frac{Q}{\Delta T_{lm} U} = 95570 \text{ft}^2$$

Purchase cost of condenser:

$$C_p = F_m F_p F_l C_B$$

C_B (Base cost; fixed head):

$$C_B = \text{EXP}(11.0343 - 0.9228(\text{LN}(A)) + 0.09861(\text{LN}(A))^2) = \$687,020$$

F_m = 1 ; Carbon steel

F_l = 1; tube length correction for L = 20ft

$$C_p = F_m F_p F_l C_B = \$687,020 ; \text{Adjusted } C_p = \$687,020 \times \frac{532.9}{500} = \$732,226$$

Bare module factor (F_m) = 4.16,

$$C_{bm} = F_m \times \text{adjusted } C_p = 4.16 \times \$1,492,542 = \$2,321,158$$

Appendix 1C: Sample Calculation for Heater and Reboiler

Modeled as shell&tube heat exchanger (fixed head); Carbon steel shell; 20ft long

Example: Distillation condenser D-100

Reboiler sizing:

To avoid boiling, heat flux = 12000 Btu/hr-ft²

From Aspen,

$$\text{Heat duty, } Q \text{ (Btu/hr)} = 625,534,412$$

$$\text{Heat exchange surface area, } A \text{ (ft}^2\text{)} = \frac{Q}{\text{heat flux}} = 52128$$

Purchase cost of reboiler:

Assume: kettle vaporizer – carbon steel

$$C_p = F_m F_p F_l C_B$$

C_B (Base cost; kettle vaporizer):

$$C_B = \text{EXP}(12.203 - 0.8709 \cdot \text{LN}(A) + 0.09003 \cdot (\text{LN}(A))^2) = \$687,020$$

$F_m = 1$; Carbon steel

$F_l = 1$; tube length correction for $L = 20\text{ft}$

$$C_p = F_m F_p F_l C_B = \$687,020 ; \text{ Adjusted } C_p = \$687,020 \times \frac{532.9}{500} = \$732,226$$

Bare module factor (F_m) = 4.16,

$$C_{bm} = F_m \times \text{adjusted } C_p = 4.16 \times \$1,492,542 = \$2,321,158$$

Appendix 1D: Sample calculation for pump and electric motor

Model type: centrifugal pump; Example: D-100 Reboiler pump

Pump sizing:

From Aspen:

Density of liquid (lb/ft³) = 82.2

Volumetric flow rate (ft³/hr) = 280.40; conversion factor to gpm = 8.02064269

Volumetric flow rate (gpm) = 34.96

Pressure increase (psi) = 0.15

$$\text{Power required (Hp)} = \frac{(\text{vol. rate})(\text{pressure increase}) \times 144}{3600 \times 330.22} = 0.00303$$

$$\text{Size factor, } S \text{ (gpm - ft}^{0.8}\text{)} = (\text{vol. rate}) \times \left(\frac{\text{pressure increase}}{\rho_L} \right)^{0.8} = 1.49$$

Purchase cost of pump:

$$C_P = F_t F_m C_B$$

Pump details:

No. of stage = 1; material = Carbon Steel and Hastelloy ($F_m = 1.4875$);

Shaft rotation = 3600 rpm; $F_t = 1$;

$$C_B \text{ (Base cost)} = \text{EXP} \left(9.7171 - 0.6019 * (\ln(S)) + 0.0519 * (\ln(S))^2 \right) = \$13,148$$

$$C_P = F_t F_m C_B = \$20,845 \quad (\text{Adjusted by CE 2010} = 532.9)$$

Motor sizing:

Motor details:

Explosion-proof motor; Shaft rotation = 3600 rpm; $F_t = 1.8$

$$\text{Pump eff.} = -0.316 + 0.24015 \ln(\text{vol rate}) - 0.01199 (\ln(\text{vol rate}))^2 = 0.39$$

$$\text{Brake horsepower, } P_b \text{ (BHp)} = \frac{\text{power required}}{\text{pump efficiency}} = 0.0079$$

$$\text{Motor efficiency} = 0.8 + 0.0319 \ln(P_b) - 0.00182 (\ln(P_b))^2 = 0.60$$

$$\text{Power consumption, } P_c = \frac{\text{brake horsepower}}{\text{motor efficiency}} = 0.013$$

Purchase cost of motor:

$$C_p = 1.85XP(5.8259 + 0.13141 \ln(P_c) + 0.053255 (\ln(P_c))^2 + 0.028628 (\ln(P_c))^3 - 0.0035549 (\ln(P_c))^4) = \$27.7$$

; (Adjusted by CE 2010 = 532.9)

Purchase cost of pump and motor:

$$C_p = C_{p_{\text{pump}}} + C_{p_{\text{motor}}} = \$20,873 ; \text{ (Adjusted by CE 2010 = 532.9)}$$

$$F_{bm} = 3.05,$$

$$C_{BM} = F_{BM} C_p = \$68,881$$

Appendix 1E: Sample Calculation for Flash Drum and Reflux Accumulator

Model: Vertical pressure vessel of appropriate capacity;

Material: carbon steel and hastelloy;

Example: F-100 Flash Drum

Flash drum sizing:

From Aspen:

$$\text{Volumetric flow rate (ft}^3/\text{hr)} = 29743.25$$

Design specifications:

$$\text{Residence time at half full (min)} = 5$$

$$\text{Aspect ratio (length/diameter)} = 2$$

$$\text{Volume (ft}^3\text{)} = \frac{(\text{vol rate})(\text{residence time})}{(60)(2)} = 4937.21$$

$$\text{Diameter (ft)} = \left(\frac{4\text{Volume}}{\text{aspect ratio}(\pi)} \right)^{\frac{1}{3}} = 14.67 ; \text{Length (ft)} = D \times \text{aspect ratio} = 29.34$$

Purchase cost of flash drum:

$$C_p = F_m C_v + C_{pi}$$

C_v (Cost of vertical vessel):

$$\text{Corrosion allowance (in)} = 0.25$$

$$\text{Minimum wall thickness (in)} = 0.50$$

$$t_s \text{ (in)} = 0.25 + 0.50 = 0.75$$

$$F_m = 1.4875; \text{ density of material} = 506.25 \text{ lb/ft}^3 \text{ (from previous sample)}$$

$$W(lb) = \pi(\text{Aspect ratio} + 0.083D)(D + 0.8\text{Aspect ratio})(0.083)t_s \rho = 3321.45$$

$$C_v = \text{EXP}(7.2756 + 0.18255(\ln(W)) + 0.02297(\ln(W))^2) = \$28,734$$

$$C_{pi} = 300.9(\text{Aspect ratio}^{0.68816})D^{0.80164} = \$4,018$$

$$C_p = F_m C_v + C_{pi} = \$46,760 ; \text{Adjusted } C_p = \$46,760 \times \frac{532.9}{500} = \$49,837$$

Bare module factor, $F_m = 4.16$,

$$C_{bm} = F_m C_p = \$207,321$$

For Reflux Accumulator, it was assumed that the vessel is horizontal. Thus, we used the following correlation to find the C_v of the horizontal vessel:

$$C_v = EXP(8.717 - 0.2330(\ln(W)) + 0.04333(\ln(W))^2) = \$42,323$$

$$C_v = EXP(7.2736 + 0.18235(\ln(W)) + 0.02297(\ln(W))^2) = \$42,323$$

Appendix 1F: Sample Calculation for Storage Tanks

Example: ST-100

Material: carbon steel; Type: Open tank; Period of storage: 2 weeks

Storage tank sizing:

From Aspen:

Temperature (F) = 248; pressure (psia) = 652.67

Volumetric rate (ft³/hr) = 434.63

Volume (gal) = (vol rate)(336 hours)(7.480519 gal/ft³) = 1,092,415

Design specifications:

Aspect ratio (Length/diameter) = 0.167

$$Diameter (ft) = \left(\frac{4}{aspect\ ratio} \left(\frac{volume}{\pi} \right) \right)^{\frac{1}{3}} = 103.71$$

$$Length (ft) = D \times aspect\ ratio = 17.29$$

Purchase cost of storage tanks:

The correlation for “open” tank:

$$C_p = 18(volume)^{0.72} = \$400,783 ; \text{ Adjusted } C_p = \$400,783 \times \frac{532.9}{500} = \$427,157 ;$$

F_m = 3.0

$$C_{bm} = C_p F_m = \$1,281,470$$

Appendix 1G: Sample Calculation for Heat Exchangers

Heat exchanger sizing

Shell & tube heat exchanger; floating head; carbon steel (Fm = 1)

Example: HX-100 Heat exchanger

Assumptions:

Tube length (ft) = 20 (F_l = 1) ; Tube inside diameter (in) = 1

Design specifications:

Shell inside diameter = 15.25 in (Seider, *et al*)

Square pitch

From Aspen:

Hot stream temp in (F)	203
Hot stream temp out (F)	202
Cold stream temp in (F)	106
Cold stream temp out (F)	201
Hot stream flow rate (lb/hr)	2.01E+06
Cold stream flow rate (lb/hr)	2.65E+04
cold stream density (lb/ft ³)	28.75
Heat transfer coefficient, U _i , (Btu/ft ² hr F)	149.693657
Heat duty, Q, (Btu/hr)	660602.923

$$\Delta T_{lm} = \frac{(T_{Hot,in} - T_{Cold,out}) - (T_{Hot,out} - T_{Cold,in})}{\left(\frac{\ln(T_{Hot,in} - T_{Cold,out})}{(T_{Hot,out} - T_{Cold,in})} \right)} = 24.28$$

Fouling factor, Ft (R,S)

$$S = \frac{(T_{Cold,out} - T_{Cold,in})}{(T_{Hot,in} - T_{Cold,in})} = 0.98$$

$$R = \frac{(T_{hot,in} - T_{hot,out})}{(T_{cold,out} - T_{cold,in})} = 0.01$$

$$Ft = 0.94$$

$$\text{Total tube inside area, } A_t(\text{ft}^2) = \frac{Q}{\Delta T_{lm} U F t} = 193.51$$

Estimate velocity inside the tube (ft/s) = 5

$$\text{Total cross sect. area per pass, } A_{ct}(\text{ft}^2) = \frac{\text{cold stream rate}}{(\text{cold stream density})(\text{velocity inside the tube})(3600)} = 0.051$$

From Aspen:

$$\text{Heat transfer area (tube outside area), } A_t N_t(\text{ft}^2) = 180.63$$

$$\text{Number of tube pass, } N_p = \frac{A_t}{A_{ct} N_t} = 1.07 = 1$$

$$\text{Number of tubes per pass, } N_t = \frac{4 A_{ct}}{\pi D_t^2} = 9.39 = 10$$

Estimate baffle spacing, b (in) = 10 (Based on Seider, *et al*)

From Aspen:

$$\text{Hot side (shell side) pressure (psig) = 2}$$

Design data summary:

Heat duty (MMBtu/hr)	0.660602923
Shell diameter (in)	15.25
Heat transfer coefficient (Btu/hr-ft ² -F)	149.693657
Heat transfer area (ft ²)	180.634765
Tube length (ft)	20
Shell length (ft)	22

Purchase cost of Heat exchanger:

$$\text{Purchase cost, } C_p = F_m F_p F_l C_b$$

$$C_b = \text{EXP}(11.667 - 0.8709 \text{LN}(A_t N_t)) + 0.09005 (\text{LN}(A_t N_t))^2 = \$14,372$$

$$F_m = 1; F_l = 1$$

$$F_p = 0.9803 + \frac{0.018(\text{hot shell side pressure})}{100} + 0.0017 \left(\frac{\text{hot shell side pressure}}{100} \right)^2 = 0.98$$

Purchase cost, $C_p = \$14,094.12$; Adjusted purchase cost, $C_p = \$14,094.12 \times 532.7/500 = \$15,022$

$$F_{bm} = 3.17,$$

$$\text{Bare module cost, } C_{bm} = F_{bm}C_p = \$47,618.21$$

Appendix 1H: Sample Calculations for Reactor System

$$V_F = M_F / \rho_L$$

$$72804.5 = 1294464 / 17.78$$

$$V = V_F * t_R / 60 * 2$$

$$145609 = 72804.5 * 60 / 60 * 2$$

$$D_i = ((4 * V) / (A * \pi))^{1/3}$$

$$35.9 = ((4 * 145609) / (4 * \pi))^{1/3}$$

$$L = A * D_i$$

$$143.7 = 35.9 * 4$$

$$t_M = D_i * 0.0313 + 0.125$$

$$1.375 \sim 35.9 * .0313 + 0.125 \text{ (the material only comes in 0.125 in intervals)}$$

$$t_S = t_C + t_M$$

$$1.625 = 1.375 + 0.25$$

$$W = \pi (D_i + t_S / 12)(L + 0.8D_i)t_S / 12 * \rho_M$$

$$28456.3 = \pi (36.2 + 1.375 / 12)(143.7 + .8 * 35.9) * 1.375 / 12 * 490$$

$$C_V = \exp[7.0132 + 0.18255\{\ln(W)\} + 0.02297\{\ln(W)\}^2]$$

$$80953.19 = \exp[7.0132 + 0.18255\{\ln(28456.3)\} + 0.02297\{\ln(28456.3)\}^2]$$

$$C_{PL} = 361.8(D_i)^{0.7396}(L)^{0.70684}$$

$$171294.52 = 361.8 * (35.9)^{0.7396}(143.7)^{0.70684}$$

$$C_P = F_M C_V + C_{PL} + V C_{PK} + C_{DR}$$

$$3379604.46 = 30000.48 * 2.95 + 80953.19 * 1 + 171.294 + 20 * 145609 + 126675.35$$

$$C_{BM} = F_{BM} C_P$$

$$14984246.90 = 4.16 * 3601982.43$$

$$V_F = \text{Volumetric Flow Rate (ft}^3\text{/hr)}$$

M_F = Feed Mass Flow Rate (lb/hr)

ρ_L = Liquid Density (lb/ft³)

t_R = Residence Time at half full (min)

V = Volume (ft³)

D_i = Diameter (ft)

L = Length (ft)

A = Aspect Ratio (L/D)

t_M = minimum wall thickness (in)

t_C = corrosion allowance (in)

t_S = shell thickness (in)

ρ_M = metal density (lb/ft³)

W = weight of the shell (lb)

C_V = Cost of vertical vessel (\$)

C_{PL} = Cost of platforms and ladders (\$)

F_M = Materials of construction factors

C_{PK} = Cost of Packing (\$/ft³)

C_{DR} = Cost of high performance liquid distributors and redistributors (\$)

C_P = Purchase cost of column with trays (\$)

F_{BM} = bare module factor

C_{BM} = bare module cost (\$)

Appendix 1i: Sample Calculations for Utilities

Cooling water:

Example: D-100 Condenser

From Aspen:

$$\text{Heat duty, } Q \text{ (btu/hr)} = 651,276,420$$

Physical properties:

$$\text{Specific heat of water (Btu/lb-F)} = 1$$

$$\text{Density of water (lb/gal)} = 8.33$$

Design specifications:

$$\text{Inlet water temp (F)} = 90$$

$$\text{Outlet water temp (F)} = 120$$

$$\Delta T_{\text{water}} \text{ (F)} = 30$$

$$\text{Amount of water required } \left(\frac{\text{gal}}{\text{hr}} \right) = \frac{Q}{\rho C_p \Delta T} = 2606148 \frac{\text{gal}}{\text{hr}} = 20,640,698,265 \frac{\text{gal}}{\text{yr}}$$

$$\text{Cost of water (\$/1000 gal)} = \$0.08; \text{ Adjusted cooling water price} = \\ \$0.08 * (532.9/500) = \$1,649,914$$

Steam, Fuel oil and Landfill disposal

Example: D-103 Reboiler; Low pressure steam

From Aspen:

$$\text{Heat duty, } Q \text{ (btu/hr)} = 8,628,054$$

$$\text{Operating pressure (psi)} = 13.9$$

$$\Delta H_{\text{vap}} \text{ (btu/hr)} = 971.9$$

$$\text{Steam required (lb/hr)} = (Q/d) = 8877.09;$$

Steam flow rate (lb/year) = **(steam flow rate)(330 days)(24 hrs) = 70,306,570.58**

Low pressure steam unit price (\$/1000 lb) = \$3.00; Adjusted (steam unit price) = \$3.20;

$$\text{Purchase cost per year} = \frac{(\$3.547,225)(0.83(70,306,570.58))}{1000} = \$3,859,176$$

Electricity

Example: P3 Pump

Assumptions:

Plant operations per year = 7128 hours

From Aspen:

Brake horsepower (Bhp) = 9.06

Motor efficiency = 0.86

$$\text{Input power required} \left(\text{kW} - \frac{\text{hr}}{\text{year}} \right) = (\text{brake horsepower}) \times \frac{0.7457}{\text{motor efficiency}} \times 7128 = 53902$$

Unit price = \$0.06; Adjusted unit price = \$0.08

$$\text{Cost per year} = (\text{Power required})(\text{Adjusted unit price}) = \$4,691.36$$

Appendix 2: Chemical Engineering Cost Indices

Table 26: 2010 Chemical Engineering Cost Indices

Chemical Engineering Plant Cost Index			
	Jan '10 Prelim.	Dec '09 Final	Jan '09 Final
CE INDEX	532.9	524.2	539.6
Equipment	631.8	618.4	642.4
Heat Exchanges and Tanks	572	554.2	603.4
Process Machinery	601.9	597.9	620
Pipe, valves and fittings	794.5	776.3	781.8
Process Instruments	419.7	417.5	389.6
Pumps and Compressions	903	895.2	902.1
Electrical equipment	469.2	467.2	457.9
Structural supports	640.2	620	671.5
Construction Labor	330.8	331.2	324.5
Buildings	494.7	494.6	500
Engineering Supervision	342.4	343.2	350.3

Appendix 3: Catalyst, Solvent, and Promoter Cost Calculations

Appendix 3: Catalyst, Solvent, and Promoter Cost Calculations

Catalyst pricing calculations						
REAC1		Patent Example	Catalyst per Volume Reactor [g/L]	Catalyst Type	Estimated Cost [\$/kg]	Total Cost for Reactor
Volume [cu. Ft.]		5	7.6	Co-tBu-Salen/Silica	3000	\$ 94,005,868.60
145608.9989		6	1.05714	Co-tBu-Salen (No Silica)	3000	\$ 13,075,968.94
		7	0.5714	Cobalt-free Silica	3000	\$ 7,067,757.02
REAC2		Patent Example	Catalyst per Volume Reactor [g/L]	Catalyst Type	Estimated Cost [\$/kg]	Total Cost for Reactor
Volume [cu. Ft.]		5	7.6	Co-tBu-Salen/Silica	3000	\$ 10,574,092.13
16378.58351		6	1.05714	Co-tBu-Salen (No Silica)	3000	\$ 1,470,828.39
		7	0.5714	Cobalt-free Silica	3000	\$ 795,004.77
Total Cost for Catalyst for Both Reactors:						\$ 14,546,797.33

Table 27: Catalyst pricing calculations

Table 28: Solvent (TFE) and promoter (NaI) cost calculations

	Amount required (lb)¹⁶	Unit cost (\$/lb)¹⁷	Total cost (\$)
TFE	1,115,835	\$ 4.08	\$ 4,555,209.57
NaI	2,730	\$ 0.45	\$ 1,240.97

¹⁶ From Aspen model

¹⁷ TFE cost is assumed to be \$9/kg or \$4.08/lb based on suggestion from Halocarbon's consultant; NaI cost is based on current market price.

Appendix 4: Utility Cost Summary

Table 29: Utility costs for relevant process units

Utility	Unit#	Utility Requirement	Unit price (adjusted)	Annual cost
Cooling water		(gal/yr)	(\$/1000 gal)	
	D-100	20,640,693,266	\$0.08	\$1,649,913.82
	D-102	11,148,501,321	\$0.08	\$891,155.45
	D-103	273,446,002	\$0.08	\$21,857.91
	C-100	541,173,083	\$0.08	\$43,258.67
	C-102	28,484,136	\$0.08	\$2,276.88
	C-101	882,847	\$0.08	\$70.57
			Total	\$2,608,533.30
Low pressure steam		(lb/yr)	(\$/1000 lb)	
	D-103	70,306,571	\$3.20	\$224,798.23
	H-100	1,109,409,468	\$3.20	\$3,547,225.83
	H-101	174,764,895	\$3.20	\$558,793.28
	H-102	433,668,152	\$3.20	\$1,386,610.55
	H-103	3,527,733	\$3.20	\$11,279.58
	H-104	20,440,229	\$3.20	\$65,355.59
			Total	\$5,794,063.05
Fuel oil		(gal/year)	(\$/1000 gal)	
	HX-106	2,814,484,991	\$1.60	\$4,499,517.15
	HX-107	986,804,228	\$1.60	\$1,577,603.92
			Total	\$6,077,121.07
Landfill		(lb/yr)		
	Sludge	1,825,465	\$0.11	\$194,558.06
			Total	\$194,558.06
Electricity		(kW-hr/yr)	(\$/kW-hr)	
	P-101	55,902	\$0.08	\$4,691.36
	P-102	3,035	\$0.08	\$254.74
	P-103	1,322	\$0.08	\$110.92
	P-100	204,374	\$0.08	\$17,151.33
	P-104	3,162,570	\$0.08	\$265,406.82
	D-100 Reboiler Pump	70	\$0.08	\$5.86
	D-101 Reboiler Pump	125	\$0.08	\$10.49
	D-102 Reboiler Pump	72	\$0.08	\$6.01
	D-100 Reflux Pump	1,040,830	\$0.08	\$87,347.77
	D-101 Reflux Pump	528,583	\$0.08	\$44,359.31
	D-102 Reflux Pump	1,815	\$0.08	\$152.28
			Total	\$419,496.89

Total utility cost \$15,093,772.37

Appendix 5: Problem Statement

6. Phosgene-Free Route to Isocyanates (recommended by Bruce Vrana, DuPont)

Isocyanates are intermediates in making polycarbonates and polyurethanes, which have many useful properties. Polycarbonates are particularly valued for their optical clarity and impact resistance, and are used in CD and DVD discs among many other applications. Polyurethanes are used in foams, elastomers and hard polymers. Isocyanates have historically been made using highly toxic phosgene. Although some small-volume aliphatic isocyanates are now made without phosgene, the large volume isocyanates – methylene diphenylene diisocyanate (MDI) and toluene diisocyanate (TDI) – are still made from phosgene. Besides the obvious toxicity issues, phosgene routes also result in copious quantities of low-value salt or HCl that must be sold or disposed of.

Recently, Repsol has patented a non-phosgene route to TDI that appears to be very attractive. Toluenediamine (TDA), the same chemical normally phosgenated to TDI, can be oxidatively carbonylated to TDI in a single step. The catalyst and solvent system patented is somewhat exotic, but can be recycled, and the prospect of a phosgene-free route is alluring.

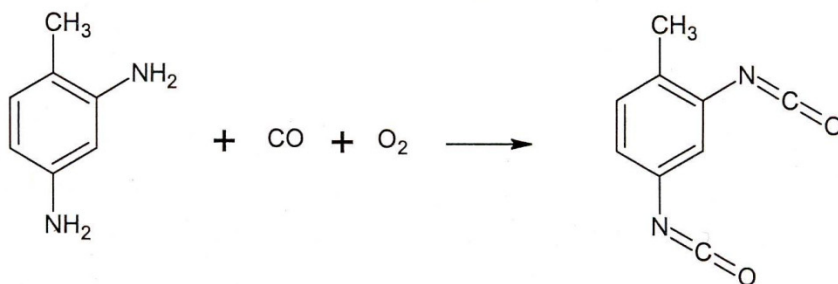

Your company has assembled your team to design the process in support of this new chemistry. Design a process to make 300MM lb/yr of TDI from TDA. TDA is available on your U.S. Gulf Coast plant for \$1.00/lb. Oxygen is available for \$0.03/lb, and carbon monoxide for \$0.10/lb. For this process to be competitive with the current route, you should use a TDI price of \$1.50/lb. All prices are forecasts by your marketing organization for long term average prices, expressed in 2010 dollars for the quantities needed delivered to your site.

You will have to make many assumptions to complete your design, since the data you have is far from complete. State them explicitly in your report, so that management may understand the uncertainty in your design and economic projections. Test your economics to reasonable ranges of your assumptions. If there are any possible “show-stoppers” (i.e., possible fatal flaws, if one assumption is incorrect that would make the design either technically infeasible or uneconomical), these need to be clearly communicated and understood.

The plant design should be as environmentally friendly as possible. Recover and recycle process materials to the maximum economic extent. Also, energy consumption should be

minimized, to the extent economically justified. The plant design must also be controllable and safe to operate. Remember that you will be there for the plant start-up and will have to live with whatever design decisions you have made.

Reference

European Patent 1,870,398, December 12, 2008, assigned to Repsol YPF S.A.

Recently, Repsol has patented a non-phosgene route to TDI that appears to be very attractive. Toluenediamine (TDA), the same chemical normally phosgenated to TDI, can be oxidatively carbonylated to TDI in a single step. The catalyst and solvent system patented is somewhat exotic, but can be recycled, and the prospect of a phosgene-free route is alluring.

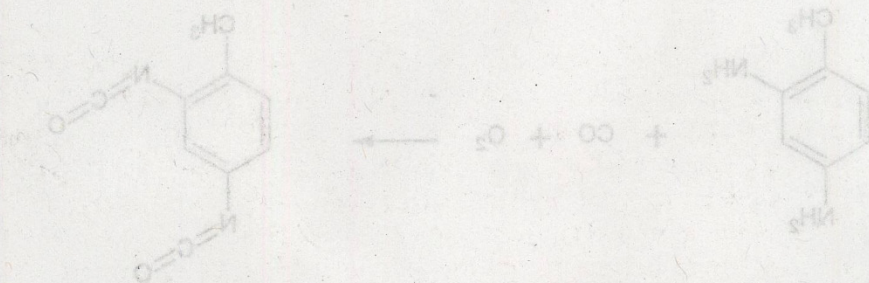

Your company has assembled your team to design the process in support of this new chemistry. Design a process to make 300MM lb/yr of TDI from TDA. TDA is available on your U.S. Gulf Coast plant for \$1.00/lb. Oxygen is available for \$0.03/lb, and carbon monoxide for \$0.10/lb. For this process to be competitive with the current route, you should use a TDI price of \$1.50/lb. All prices are forecasts by your marketing organization for long term average prices, expressed in 2010 dollars for the quantities needed delivered to your site.

You will have to make many assumptions to complete your design, since the data you have is far from complete. State them explicitly in your report, so that management may understand the uncertainty in your design and economic projections. Test your economic to reasonable ranges of your assumptions. If there are any possible "show-stoppers" (i.e., possible fatal flaws, if one assumption is incorrect that would make the design either technically infeasible or uneconomical), these need to be clearly communicated and understood.

The plant design should be as environmentally friendly as possible. Recover and recycle process materials to the maximum economic extent. Also, energy consumption should be

**Appendix 6: US Patent
7423171 – One-Step
Catalytic Process for the
Synthesis of Isocyanates**

US Patent 7423171 - One-step catalytic process for the synthesis of isocyanates

US Patent Issued on September 9, 2008

Estimated Patent Expiration Date: **June 20, 2027**

Abstract

A one-pot process for the synthesis of isocyanates, polyisocyanates or mixtures thereof which includes the steps of: i. preparing a mixture comprising an amine, an alcohol, an oxygen-containing gas, carbon monoxide, a metal complex catalyst selected from the group consisting of macrocyclic complex catalysts and cobalt Schiff base catalysts; and a solvent selected from the group consisting of aliphatic or aromatic halocarbons, perhalogenated alcohols, halogenated ethers, halogenated ketones, perfluorinated hydrocarbons, polymers of chlorotrifluoroethylene having the formula $-(CF_2-CFCl)_n$ wherein n is between 2 and 10, and mixtures thereof; ii. subjecting the resulting mixture to a first heating under pressure; iii. cooling and depressurizing the mixture resulting from the previous step; and iv. subjecting the mixture of the previous step to a second heating to separate out the isocyanate product from the mixture.

Claims

What is claimed is:

1. A one-pot process for the synthesis of isocyanates, polyisocyanates or mixtures thereof, which comprises the steps of: i. preparing a mixture comprising an amine, an alcohol, an oxygen-containing gas, carbon monoxide, a metal complex catalyst selected from the group consisting of macrocyclic complex catalysts and cobalt Schiff base catalysts; and a solvent selected from the group consisting of aliphatic or aromatic halocarbons, perhalogenated alcohols, halogenated ethers, halogenated ketones, perfluorinated hydrocarbons, polymers of chlorotrifluoroethylene having the formula $-(CF_2-CFCl)_n$ wherein n is between 2 and 10, and mixtures thereof; ii. subjecting the resulting mixture to a first heating under pressure; iii. cooling and depressurizing the mixture resulting from the previous step; and iv. subjecting the mixture of the previous step to a second heating to separate out an isocyanate product from the mixture.
2. The process according to claim 1, wherein said solvent is selected from the group consisting of 2,2,2-trifluoroethanol, 2,2,3,3-tetrafluoro-1-propanol, 1,1,1,3,3,3-hexafluoropropan-2-ol, perfluoro-*n*-hexane, perfluoro-*n*-heptane, perfluoro-*n*-nonane, perfluorodecaline, nonafluoro tertbutanol, and mixtures thereof.
3. The process according to claim 2, wherein the solvent is 2,2,2-trifluoroethanol.
4. The process according to claim 1, wherein the alcohol is present in more than stoichiometric amounts so as to act as both (co)solvent and reactant.

5. The process according to claim 1, wherein the temperature in said first heating is in a range of from 100 to 200° C., and the pressure is in a range of from 5 to 100 bar.
6. The process according to claim 5, wherein the temperature in said first heating is in a range of from 120 to 180° C., and the pressure is in a range of from 20 to 70 bar.
7. The process according to claim 1, wherein the temperature in said second heating is in a range of from 50 to 240° C.
8. The process according to claim 1, wherein a cosolvent is added prior to said second heating.
9. The process according to claim 1, wherein step iv. comprises at least one distillation to remove solvents and at least one distillation to separate the isocyanate product.
10. The process according to claim 9, wherein said distillations are independently selected from distillations under pressure, distillations under vacuum and distillations at atmospheric pressure.
11. The process according to claim 9, wherein said first distillation is carried out at a temperature in a range of from 50 to 180° C. and under a pressure in a range of from 0.1 to 10 bar, and said second distillation is carried out at a temperature in a range of from 140 and 240° C. and under a pressure in a range of from 1 to 900 mbar.
12. The process according to claim 9, characterised in that the distilled solvents are recycled for further reactions.
13. The process according to claim 1, comprising a continuous process.
14. The process according to claim 13, wherein the space velocity is in a range of from 20 to 40.000 h⁻¹.
15. The process according to claim 13, wherein the distilled solvent is recycled into the reaction.
16. The process according to claim 1, wherein the metal of the metal complex catalyst is selected from metals of Group VIII.
17. The process of claim 1, wherein the metal complex catalyst is selected from the group consisting of cobalt porphyrins of formula I ##STR00004## wherein R¹ and R² are each independently selected from hydrogen, cyano, substituted or unsubstituted alkyl, substituted or unsubstituted cycloalkyl, substituted or unsubstituted alkenyl, substituted or unsubstituted alkynyl, substituted or unsubstituted aryl, substituted or unsubstituted heterocyclyl; or R¹ and R² together form a substituted or unsubstituted cycloalkyl, substituted or unsubstituted cycloalkenyl, substituted or unsubstituted cycloalkinyl, substituted or unsubstituted aryl,

substituted or unsubstituted heterocyclyl; R³ is selected from hydrogen, cyano, substituted or unsubstituted alkyl, substituted or unsubstituted cycloalkyl, substituted or unsubstituted alkenyl, substituted or unsubstituted alkynyl, substituted or unsubstituted aryl, substituted or unsubstituted heterocyclyl; a cobaltphthalocyanine of formula II ##STR00005## wherein R¹ and R² have the same meaning as in formula I; and a cobalt Shiff base catalyst of formula III ##STR00006## wherein R¹ and R² have the same meaning as in formula I; R⁴, R⁵, R⁶ and R⁷ are each independently selected from among hydrogen, cyano, substituted or unsubstituted linear alkyl, substituted or unsubstituted branched alkyl, substituted or unsubstituted alkoxy, --O--Si--R¹⁰, wherein R¹⁰ is a substituted or unsubstituted alkyl, substituted or unsubstituted cycloalkyl, substituted or unsubstituted alkenyl, substituted or unsubstituted alkynyl, substituted or unsubstituted aryl, substituted or unsubstituted heterocyclyl; R⁹ and R⁸ are each independently selected from hydrogen, cyano, substituted or unsubstituted alkyl, substituted or unsubstituted cycloalkyl, substituted or unsubstituted alkenyl, substituted or unsubstituted alkynyl, substituted or unsubstituted aryl, substituted or unsubstituted heterocyclyl; and mixtures thereof.

18. The process according to claim 17, wherein R⁴, R⁵, R⁶ and R⁷ are each independently selected from a substituted or unsubstituted branched alkyl group.

19. The process according to claim 17, wherein R⁵ and R⁷ are each independently selected from a C₁₋₄-alkoxy group.

20. The process according to claim 1, wherein the catalyst comprises a solid support selected from the group consisting of silica, inorganic refractory metal oxides, zeolites, carbon and polymers or mixtures thereof.

21. The process according to claim 1, wherein the amine is selected from the group consisting of substituted or unsubstituted aryl amines, substituted or unsubstituted aryl diamines, polyaminopolyphenylmethanes and mixtures thereof.

22. The process according to claim 21, wherein the amine is selected from the group consisting of toluenediamines, diaminodiphenylmethanes and mixtures thereof.

23. The process according to claim 1, wherein a halide promoter selected from the group consisting of alkali metal halides, alkaline earth metal halides, onium halides, compounds capable of forming onium halides at contacting conditions, oxoacids of halogen atoms and their salts, organic halides and halogen molecules and mixtures thereof, is added prior to the first heating under pressure.

Description

CROSS-REFERENCE TO RELATED APPLICATION

The priority of European Patent Application No. EP 06380178.1 filed Jun. 20, 2006 is hereby

claimed under the provisions of 35 USC 119. The disclosure of said European Patent Application No. EP 06380178.1 is hereby incorporated herein by reference in its entirety, for all purposes.

FIELD OF THE INVENTION

The present invention is related to the direct conversion of amines into isocyanates, and to a catalytic chemical process for effecting such conversion to produce isocyanates.

BACKGROUND OF THE INVENTION

Isocyanates are important chemicals. For example, the world production of isocyanates exceeded 5 megatons in 2001. Traditionally, isocyanates are manufactured on a commercial scale by reaction of phosgene with amines or amine salts. This reaction, however, has several serious drawbacks. Phosgene is an extremely toxic reagent and a stoichiometric amount of HCl is produced as a by-product. Furthermore, HCl causes serious corrosion, and a stoichiometric amount of NaOH is required to neutralize the HCl, where the same amount of NaCl is formed. As restrictions upon the use of very toxic materials such as phosgene within the chemical industry have become more rigorously enforced, there has been increasing interest in developing alternative methods to phosgene in the synthesis of isocyanate.

As an alternative, the use of dimethyl carbonate or dimethyl sulfate as phosgene substitutes are relatively expensive for commercial applications (see M. Selva et. al., Tetrahedron Letters, 2002, 43 (7), 1217-1219; JP 20044262835; WO 98/56758; WO 99/47493).

Many other strategies for non-phosgene routes, including reductive carbonylation and oxidative carbonylation by using CO as carbonyl source, have been reported. One promising alternative approach that has been the subject of research in recent years involves the oxidative carbonylation of amines to carbamates in the presence of an alcohol, usually methanol, followed by catalytic decomposition of the carbamates to isocyanates.

Alper and Hartstock (J. Chem. Soc., Chem. Commun. 1141, 1985) disclose catalytic systems including palladium chloride, copper chloride and hydrochloric acid to produce carbamates from amines. This Wacker-type catalytic system, consisting of $\text{PdCl}_2\text{-CuCl}_2\text{-HCl}$, is disclosed as being effective at mild conditions (1 atm and room temperature) in the oxidative carbonylation of amines to produce high yields of carbamate. In this system carbon monoxide (CO) and oxygen (O_2) are bubbled through an alcohol to which is added PdCl_2 and, finally, the amine. The mixture is stirred overnight, at room temperature and pressure, and filtered. The filtrate is subject to rotary evaporation. The resulting oil is treated with either diethyl ether or acetone and filtered, and concentration of the filtrate yields the carbamate ester. Further purification is carried out by thin-layer or column chromatography (silica gel).

Gupte and Chaudhari, Journal of Catalysis, 114, 246-258, 1988, studied the oxidative carbonylation of amines using a Pd/C-Nal catalytic system. Although effective at producing carbamates, this catalytic system uses a CO/O_2 molar ratio of 5/1, which is inside the

flammability envelope.

US 2002/0183541 employ a Group VIII metal catalyst and/or copper-based catalyst with halide promoters to produce carbamate esters through heterogeneous oxidative carbonylation in a gas-solid carbonylation process. The carbamate produced remainson the catalyst surface and must be recovered through expensive extraction and distillation steps.

T. W. Leung, J. Chem. Soc. Chem. Comm., 3, 1992, 205-6 and U.S. Pat. No. 5,194,660 describes a process for producing carbamates, using a homogeneous catalyst that comprises contacting a first reactant selected from primary amine components, secondary amine components, urea components and mixtures thereof; carbon monoxide; at least one oxygen-containing oxidizing agent, in the presence of catalyst composition comprising at least one metal macro-cyclic complex, preferably in the furtherpresence of one iodine component. The macro-cyclic complex is selected from the group consisting of metal porphyrin or metal phthalocyanine including a metal selected from the metals of group IIIa to Va and group VIII of the Periodic Table and at leastone iodine component is present in an amount effective to facilitate the formation of the carbamate.

A. Bassoli et al., J. Mol. Catal. 1990, 60, 41 teaches the formation of ureas in good yields, with small amounts of carbamates and azo derivatives via the N,N-bis(salicylidene)ethylenediaminocobalt(II)-catalyzed oxidative carbonylation of aromatic primary amines in methanol.

E. Bolzacchini et al., J. Mol. Catal. A: Chemical, 111, 1996, 281-287, describes the N,N-bis(salicylidene)ethylenediaminocobalt(II)-catalyzed oxidative carbonylation of substituted aromatic primary amines in methanol to give blends of ureas, isocyanates, carbamates and azoderivatives. Such blends are unsuitable for the synthesis of commercial isocyanates. Further, the long reaction times required (48 hours) precludes the practical industrial application of this approach.

US Patent Application Publication 2003/0162995 describes a one-pot synthesis of isocyanates by reaction of amines with dimethyl carbonate and subsequent heating to obtain the isocyanate. Due to reaction conditions, the separation of the isocyanate product involves a complicated separation process which comprises water addition, further heating, filtration and a number of distillations in order to obtain the isocyanate, in impure form, which then must be further purified.

Therefore, there is an extensive literature regarding the production of isocyanates and polyisocyanates. The most commonly used procedure involves the transformation of an amine into the corresponding carbamate in a first step, followed by the thermal decomposition of the carbamate to obtain the desired isocyanate or polyisocyanate. A large number of prior publications refer to one of these two steps.

For example, as mentioned above, U.S. Pat. No. 5,194,660 discloses a method for the

preparation of carbamates. However, the synthesis of the corresponding isocyanates is only suggested and only from the corresponding carbamates after isolation. Further, according to U.S. Pat. No. 5,194,660 it is necessary to isolate the carbamate intermediate prior to its conversion into the desired isocyanate.

Only a few references mention or suggest the possibility of direct transformation of amines into the corresponding isocyanates. However, as in US Patent Application Publication 2003/0162995, they usually require complicated separation steps.

In view of all of the above, there is an existing need to provide an alternative cost-effective and efficient method for the direct synthesis of isocyanates and polyisocyanates.

SUMMARY OF THE INVENTION

An efficient, safe and cost effective one-pot process for the synthesis of isocyanate products has now been surprisingly found.

The one-pot catalytic process disclosed herein satisfies the need in the art for an industrially viable oxidative carbonylation process capable of producing isocyanate products, which at the same time does not require the isolation of intermediate carbamates.

Further, the process according to the present invention does not involve complicated separation steps. The isocyanate products are separated by means of distillation of the reaction mixture and, usually, the isocyanate product is obtained in essentially pure form.

Further, the present invention overcomes to a large extent the hazards associated with the direct reaction of carbon monoxide and oxygen in the presence of organic compounds by dissolving the reactant gases in a reaction solvent (e.g. halocarbons and/or oxygenated fluorinated hydrocarbons).

Therefore, an aspect of the present invention is a one-pot process for the synthesis of isocyanates, polyisocyanates or mixtures thereof, which comprises the steps of: i preparing a mixture comprising an amine, an alcohol, an oxygen-containing gas, carbon monoxide, a metal complex catalyst selected from the group consisting of macrocyclic complex catalysts and cobalt Schiff base catalysts and a solvent, selected from the group consisting of aliphatic or aromatic halocarbons, perhalogenated alcohols, halogenated ethers, halogenated ketones, perfluorinated hydrocarbons, polymers of chlorotrifluoroethylene having the formula $-(CF_2-CFCl)_n$ wherein n is between 2 and 10, and mixtures thereof; ii subjecting the resulting mixture to a first heating under pressure; iii cooling and depressurizing the mixture resulting from the previous step; and iv subjecting the mixture of the previous step to a second heating to separate out the isocyanate product from the mixture.

Additional features, aspects and embodiments of the invention will be more fully apparent from the ensuing disclosure and appended claims.

DETAILED DESCRIPTION OF THE INVENTION

It is known that explosive concentration of carbon monoxide in oxygen at 200° C. and atmospheric pressure is between 14.2-95.3%, thus, the range is extremely broad. It is also known that dilution of the gaseous mixture with an inert gas like nitrogen scarcely changes the lower limit concentration. Further, variation of pressure between 1-200 atmospheres and temperatures between 0-200° C. have a modest effect on the explosive range. Furthermore, even when these reactants are brought together in a ratio that, in homogeneous conditions, would be outside the flammability envelope, the establishment of homogeneity from pure components involves at least a temporary passage through the flammability envelope. For these reasons, the explosion risks associated with the direct contact of carbon monoxide and oxygen are not easily mitigated. Furthermore, unfortunately, carbon monoxide and oxygen are only slightly soluble in the alcohols used as solvents and reactants in the prior art, which limits the concentration of these two components in the reaction mixture and thus results in a lower speed of reaction.

In the present invention the solvent is selected from the group of aliphatic or aromatic halocarbons, perhalogenated alcohols, halogenated ethers, halogenated ketones, perfluorinated hydrocarbons, polymers of chlorotrifluoroethylene having the formula $-(CF_2-CFCl)_n$ wherein n is between 2 and 10, and mixtures thereof. These solvents possess high oxygen solubility and allow for a higher concentration of oxygen in reaction mixture at a given oxygen partial pressure. Therefore, by using the solvents of the invention, it is possible to reduce the partial pressure of oxygen and still maintain an acceptable concentration of oxygen in the reaction mixture so that a good speed of reaction can be obtained and, at the same time, the safety of the process is improved by working well outside the flammability envelope and in conditions of lower temperatures and pressures than those used in the prior art.

Halocarbons are preferably aryl halocarbons such as chlorobenzene, dichlorobenzene and trichlorobenzene, fluorocarbons, chlorofluorocarbons, and hydrochlorofluorocarbons. Preferred reaction solvents are the completely fluorine-substituted $C_{5-C_{10}}$ hydrocarbons such as perfluoro-n-hexane, perfluoro-n-heptane, perfluoro-n-nonane, perfluorodecaline or nonafluoro tertbutanol. These liquids are available under various trade names, such as 3M™ Performance Fluids (Minneapolis, Minn.). Polymers of chlorotrifluoroethylene are also commercially available, such as the grade 0.8 of Halocarbon Product Corporation of USA. Those halocarbons can be added to the reaction mixture or at the outlet of the reactor to facilitate the workup of the mixture or to facilitate its cooling.

The halocarbons and particularly fluorinated hydrocarbons are especially inert versus strong oxidizing agents, including oxygen, and dissolve gases readily. For example, it is known that solubility of oxygen in perfluoroalkanes is extremely high (Clark L. C. et al. Pure Appl. Chem., 1982, 54, 2383-2406 and Marrucho, I. M., Fluid Phase Equilibria, 222-223, 2004, 325-330). This is the reason why the present process can use lower pressures to achieve the same concentrations of the reactive gases in the liquid medium of reaction compared with the prior

art processes that produce carbamates, and easily avoids gaseous environment containing any explosive mixture of reactants above the liquid reaction system.

According to a preferred embodiment, solvents are oxygenated fluorinated hydrocarbons (e.g. fluorinated alcohols and its blends with fluorinated ethers and/or ketones), where at least one alkyl hydrogen of the homologous oxygenate is substituted for fluorine. Preferred oxygenated fluorinated hydrocarbons include, without limitation, 2,2,2-trifluoroethanol, 2,2,3,3-tetrafluoro-1-propanol, 1,1,1,3,3,3-hexafluoropropan-2-ol, fluorophenols and mixtures thereof, preferably 2,2,2-trifluoroethanol. One preferred fluorinated ether is nonafluorobutyl methyl ether. One preferred fluorinated ketone is hexafluoroacetone.

According to a most preferred embodiment, the preferred solvents can be defined on the basis of their oxygen solubility measured in molar fraction of oxygen in the solvent. Thus, preferred solvents are those falling within the oxygen solubility range of 10^{-5} to 10^{-1} (limits of the range included in this and in the next cases); more preferred solvents are those falling within the range $5 \cdot 10^{-5}$ to $5 \cdot 10^{-1}$; even more preferred solvents are those falling within the range 10^{-4} to $5 \cdot 10^{-2}$; finally, the most preferred solvents are those falling within the range $4 \cdot 10^{-4}$ to $7 \cdot 10^{-3}$ as, for example, perfluoro-n-hexane, perfluoro-n-heptane, perfluoro-n-nonane, perfluorodecaline, 1,1,1,3,3,3-hexafluoropropan-2-ol and 2,2,2-trifluoroethanol.

In order to carry out the oxidative carbonylation, the presence of an alcohol is necessary since it acts as a reagent in the process of the invention. According to one preferred embodiment, such alcohol is a perhalogenated alcohol. As mentioned above, perhalogenated alcohols are good oxygen solvents. Therefore, perhalogenated alcohols can be present in the mixture of step i. in more than stoichiometric amount, and at the same time act as both, as reactant and as (co)solvent.

The feed and oxidizing agent can be dissolved in the reaction solvent in any order or fed simultaneously in separate streams to the reaction solvent. For example, it is possible to dissolve oxygen in the reaction solvent to saturation and subsequently contact the resulting oxygen-saturated reaction solvent with the aromatic amine, the catalyst and carbon monoxide in a tubular mixer. Using the reaction solvents described above, the carbon monoxide solubility is generally affected to only a minor extent by the presence of oxygen in the reaction solvent.

In a further embodiment, risk of gas-phase contacting of reactants may also be eliminated by independently dissolving oxygen in the reaction solvent and carbon monoxide in the aromatic amine or polyamine. In this case, the dissolution steps may be carried out, for example, in separated stirred tanks before mixing all the reagents. Thus, it is not necessary to dissolve all the reagents in the same reaction vessel or at the same time. It is certainly possible that the reaction solvent containing previously dissolved reactants can be passed through a fixed bed of catalyst or reacted in a slurry reactor. In the latter case, mechanical agitation (e.g. stirring, shaking, vibrating, etc.) can be used to effect the contacting between the catalyst and the reactants. It is also possible to use a liquid fluidized bed of catalyst, using a flow of gaseous carbon monoxide as described in "Perry's Chemical Engineers' Handbook, Sixth edition", 1984

pages 4-25, 4-26, 20-3 and 20-58 to 20-75.

According to one embodiment, the temperature during the first heating is in a range of from 100 to 200° C., preferably from 120 to 180° C., and pressure is in a range of from 5 to 100 bar, preferably from 20 to 70 bar. These conditions assure an effective oxidative carbonylation. The reaction time can vary depending on the reaction system employed, catalyst and other reaction conditions chosen. A typical reaction time is in the range of from about one minute to about 3 hours.

According to a further embodiment, after the reaction mixture is cooled, the temperature during the second heating is in a range of from 50 to 240° in order to separate the solvent by distillation and recover the isocyanate product. Between step iii and iv an additional step comprising separating the catalyst from the reaction mixture may be optionally performed.

According to a further embodiment, the separation of the solvent (step iv.) can be done through one, two or more, preferably two, consecutive distillation processes. Depending on the relative boiling points and nature of the isocyanate product and the solvents used, it is possible to directly obtain the isocyanate product by heating and subsequent distillation(s). Once the isocyanate product has been separated, without further treatment, the solvent may be recovered by a second subsequent distillation(s) of the mixture resulting from the first distillation(s). If the boiling point of the solvent is lower than the boiling point of the isocyanate product, it is possible to carry out a first distillation(s) to recover the solvent, followed by separation of the isocyanate product. Other combinations will be apparent to the skilled person depending on the relative boiling points and nature of the isocyanate product and the solvents used. In any case, the solvent recovered may be recirculated for use in further reactions.

According to a further embodiment, the first distillation(s) is carried out at a temperature in a range of from 50 to 180° C. and under a pressure in a range of from 0.1 to 10 bar, and the second distillation(s) is carried out at a temperature in a range of from 140 to 240° C. and under a pressure in a range of from 1 to 900 mbar. The condensation heat of the solvent from the first apparatus can be used for partially vaporizing solvent in the second apparatus. Recovered reaction solvent that is generated by this separation is normally most economically returned to the reaction solvent phase of the reactor for further reactions.

According to a further embodiment, prior to the second heating (step iv.), it is possible to add a cosolvent to the reaction mixture, for example, 1,2-dichlorobenzene or 1,2,4-trichlorobenzene. The addition of the cosolvent further facilitates the dissolution of the carbamate intermediate and the ulterior separation of the isocyanate product with higher purity. In this way, the work-up of the reaction becomes easier.

The raw isocyanates obtained, can be purified, if desired, in a column with a top pressure of from 1 to 950 mbar, preferably from 5 to 250 mbar, and a bottom temperature of 60-250° C., with the pure isocyanates flow being withdrawn in liquid or gaseous form, preferably in a side-stream of the column.

It has been found that the isocyanate products obtained following the process of the present invention are essentially pure and without the need of further purification. Therefore, the process of the present invention provides a simple way for the industrial synthesis of isocyanate products without the need to isolate and/or purify intermediate products to achieve good yields and purity of isocyanates.

The process according to the present invention can be carried out either batch-wise or in a continuous process by removing continuously the reaction mixture from the reaction system while continuously feeding the reactants into the reaction system. According to one embodiment of the invention, the process is a continuous process wherein space velocity is in a range of from 20 to 40,000 h⁻¹ and the distilled solvent is recycled into the reaction.

Suitable amines and polyamines to be converted into isocyanates according to the invention include substituted and unsubstituted aryl amines, for example, aniline, toluidine, 3,3'-dimethyl-4,4'-diphenylamine, phenylenediamines, toluenediamines, 2,4'- and 4,4'-methylenedianiline, sulfonyldianilines, thiodianilines, diaminodiphenylmethanes and higher homologs polyaminopolyphenylmethanes, m-phenylenediamine, 1,5-naphthylenediamine and the like, and mixtures thereof; and substituted and unsubstituted aryl diamines or higher functionality polyamines like toluenediamines, diaminodiphenylmethanes or polyaminopolyphenylmethanes or any mixture thereof.

The metal of the catalyst according to the present invention preferably is a metal selected from the metals of Group VIII and more preferably the metal is cobalt. According to one embodiment of the present invention, the metal complex catalyst is selected from a cobalt porphyrin of formula I

##STR00001## wherein R¹ and R² are each independently selected from hydrogen, cyano, substituted or unsubstituted alkyl, substituted or unsubstituted cycloalkyl, substituted or unsubstituted alkenyl, substituted or unsubstituted alkynyl, substituted or unsubstituted aryl, substituted or unsubstituted heterocyclyl; or R¹ and R² together form a substituted or unsubstituted cycloalkyl, substituted or unsubstituted cycloalkenyl, substituted or unsubstituted cycloalkynyl, substituted or unsubstituted aryl, substituted or unsubstituted heterocyclyl; R³ is selected from hydrogen, cyano, substituted or unsubstituted alkyl, substituted or unsubstituted cycloalkyl, substituted or unsubstituted alkenyl, substituted or unsubstituted alkynyl, substituted or unsubstituted aryl, substituted or unsubstituted heterocyclyl; or a cobalt phthalocyanine of formula II

##STR00002## wherein R¹ and R² have the same meaning as in formula I; or a cobalt Schiff base catalyst of formula III

##STR00003## wherein R¹ and R² have the same meaning as in formula I; R⁴, R⁵, R⁶ and R⁷ are each independently selected from hydrogen, cyano, substituted or unsubstituted linear alkyl, substituted or unsubstituted branched alkyl, substituted or unsubstituted alkoxy, --O--Si--R¹⁰,

wherein R¹⁰ is a substituted or unsubstituted alkyl, substituted or unsubstituted cycloalkyl, substituted or unsubstituted alkenyl, substituted or unsubstituted alkynyl, substituted or unsubstituted aryl, substituted or unsubstituted heterocyclyl; R⁹ and R⁸ are each independently selected from hydrogen, cyano, substituted or unsubstituted alkyl, substituted or unsubstituted cycloalkyl, substituted or unsubstituted alkenyl, substituted or unsubstituted alkynyl, substituted or unsubstituted aryl, substituted or unsubstituted heterocyclyl; or mixtures thereof.

According to one preferred embodiment, R⁵ and R⁷ are each a C_{1-C.sub.4}-alkoxy group.

According to another preferred embodiment, R⁴, R⁵, R⁶ and R⁷ are each independently selected from a substituted or unsubstituted branched alkyl group.

According to one preferred embodiment, the catalyst of the invention comprises a solid support. Catalyst supports can provide high surface area to disperse active catalyst components and immobilize the active catalyst components and allow an easy recovery of the catalyst. When carbon monoxide, oxygen and the amine react on the catalyst surface, the reaction products migrate into the organic phase, from which isocyanate products can be recovered by conventional distillation. Useful supports are well known in the art and may include, by way of non-limiting example, activated carbon and/or clay, i.e., montmorillonite; polymer supports such as poly(styrene-divinylbenzene), polystyrene, and polyimide; mesoporous materials such as zeolite, MCM-41, ZSM-5, HZSM-5, ammonium ZSM-5 and SBA-15; and metal oxides such as gamma-Al_{2O.sub.3}, SiO₂ and TiO₂, and MgO, silica or inorganic refractory metal oxides.

Such supported catalysts can be prepared by known methods. For example, Co-clay can be prepared by anchoring the salen ligand in the interlayers of montmorillonite and subsequent complexation with cobalt acetate by the method described by Choudhari et al. (J. Chem. Soc., Chem. Commun., 1987, 1505); the immobilization of Co-salen derivatives on mesoporous silica gel and MCM-41 by using grafting reactions, for example, according to I. C. Chisem et al., Chem. Commun. 1998, 1949; P. Sutra et al. Chem. Commun. 1996, p. 2485; X.-G Zhou et al. Chem. Commun. 1999, 1789 or R. J. P. Corriu et al., J. Mater. Chem., 2002, 12, 1355-1362 or by the method described in US Patent Application Publication 2005/0131252.

Further, the process of the present invention can be carried out in the absence or in the presence of a promoter. According to one embodiment, the halide promoter can be selected from alkali metal halides, alkaline earth metal halides, onium halides, compounds capable of forming onium halides at the contacting conditions, oxo acids of halogen atom and their salts, organic halides and halogen molecules. Those compounds containing iodine are particularly preferred. These include KI, NaI, LiI, CsI, tetrabutylammonium iodine, tetraheptyl ammonium iodide, iodous acid, iodine and the like.

In the above definition of the process and compounds and in the description and claims the following terms have the meaning indicated:

"One-pot" refers to processes which do not involve isolation of any intermediates prior to recovery of the final product, regardless of the number of steps required.

The term "under pressure" is understood as a pressure above atmospheric pressure, that is, above 1 atmosphere.

"Essentially pure" refers to compounds which require no purification prior to further use. Typically, a product having purity higher than 98% w/w is considered essentially pure. However, for some applications isocyanate products having purity higher than 95% w/w are also considered essentially pure.

"perhalogenated" refers to organic molecules in which hydrogen is substituted in two or more positions by a halogen group, preferably in all positions. For example, perhalogenated alkyl groups are those in which at least two hydrogen atoms are substituted by a halogen atom, e.g., chlorine, bromine, iodine, or fluorine.

"halogenated" refers to organic molecules in which hydrogen is substituted in at least one position by a halogen group. Therefore, perhalogenated molecules are comprised within the group of halogenated molecules.

"isocyanate product" refers to the products obtained by putting into practice the process according to the present invention, including isocyanates and polyisocyanates.

"Alkyl" refers to a straight or branched hydrocarbon chain radical consisting of carbon and hydrogen atoms, containing no saturation, having 1-12, preferably one to eight carbon atoms, and which is attached to the rest of the molecule by a single bond, e.g., methyl, ethyl, n-propyl, i-propyl, n-butyl, t-butyl, n-pentyl, etc. Alkyl radicals may be optionally substituted by one or more substituents such as halo, hydroxy, alkoxy, OPr, OBn, OBz, carboxy, cyano, carbonyl, acyl, alkoxy carbonyl, amino, imino, nitro, mercapto and alkylthio.

"Alkoxy" refers to a radical of the formula --ORa where Ra is an alkyl radical as defined above, e.g., methoxy, ethoxy, propoxy, butoxy etc.

"Aryloxy" refers to a radical of formula --ORb wherein Rb is an aryl radical as defined below.

"Amino" refers to a radical of the formula --NH₂, --NHRa, --NRaRb.

"Aryl" refers to an aromatic hydrocarbon radical such as phenyl, naphthyl or anthracyl. The aryl radical may be optionally substituted by one or more substituents such as hydroxy, mercapto, halo, alkyl, phenyl, alkoxy, haloalkyl, nitro, cyano, dialkylamino, aminoalkyl, acyl and alkoxy carbonyl, as defined herein.

"Aralkyl" refers to an aryl group linked to an alkyl group, such as benzyl and phenethyl.

"Alcohol" makes reference to an alkyl comprising 1 to 12 carbon atoms and substituted by at least one hydroxyl group.

"Cycloalkyl" refers to a saturated carbocyclic ring having from 3 to 8 carbon atoms.

"Heterocyclyl" refers to a stable 3- to 15-membered ring which consists of carbon atoms and from one to five heteroatoms selected from the group consisting of nitrogen, oxygen, and sulfur, preferably a 4- to 8-membered ring with one or more heteroatoms, more preferably a 5- or 6-membered ring with one or more heteroatoms. For the purposes of this invention, the heterocycle may be a monocyclic, bicyclic or tricyclic ring system, which may include fused ring systems; and the nitrogen, carbon or sulfur atoms in the heterocyclyl radical may be optionally oxidized; the nitrogen atom may be optionally quaternized; and the heterocyclyl radical may be partially or fully saturated or aromatic. Examples of such heterocycles include, but are not limited to, azepines, benzimidazole, benzothiazole, furan, isothiazole, imidazole, indole, piperidine, piperazine, purine, quinoline, thiadiazole, and tetrahydrofuran.

"Aromatic halocarbon" in the present invention refers to compounds comprising an aromatic residue substituted with one or more halogen atoms.

"Complex" refers to a molecule which is formed by two components: a donor and an acceptor. Bonding between both components to form the complex is possible because the donor may donate an unshared pair of electrons or electrons on π orbitals, which the acceptor can accommodate. In a complex more than one donor and/or more than one acceptor are possible. Also, in the same "complex" one donor may be bonded to more than one acceptor and vice versa. Besides the donor-acceptor interactions described above, other types of bonding known to the skilled person, such as covalent bonding, may exist between the donor and the acceptor.

References herein to substituted groups in the compounds of the present invention refer to the specified moiety that may be substituted at one or more available positions by one or more suitable groups, e.g., halogen such as fluoro, chloro, bromo and iodo; cyano; hydroxyl; nitro; azido; alkanoyl such as a C1-12 alkanoyl group such as acyl and the like; carboxamido; alkyl groups including those groups having 1 to about 12 carbon atoms or from 1 to about 6 carbon atoms and more preferably 1-3 carbon atoms; alkenyl and alkynyl groups including groups having one or more unsaturated linkages and from 2 to about 12 carbon or from 2 to about 6 carbon atoms; alkoxy groups having one or more oxygen linkages and from 1 to about 12 carbon atoms or 1 to about 6 carbon atoms; aryloxy such as phenoxy; alkylthio groups including those moieties having one or more thioether linkages and from 1 to about 12 carbon atoms or from 1 to about 6 carbon atoms; alkylsulfinyl groups including those moieties having one or more sulfinyl linkages and from 1 to about 12 carbon atoms or from 1 to about 6 carbon atoms; alkylsulfonyl groups including those moieties having one or more sulfonyl linkages and from 1 to about 12 carbon atoms or from 1 to about 6 carbon atoms; aminoalkyl groups such as groups having one or more N atoms and from 1 to about 12 carbon atoms or from 1 to about 6 carbon atoms; carbocyclic aryl having 6 or more carbons, particularly phenyl or naphthyl and aralkyl such as benzyl. Unless otherwise indicated, an optionally substituted group can have a

substituent at each substitutable position of the group, and each substitution is independent of the other.

Unless otherwise stated, the compounds obtainable by the process of the invention are also meant to include compounds which differ only in the presence of one or more isotopically enriched atoms. For example, compounds obtainable by the process of the invention having the same structures except for the replacement of a hydrogen by a deuterium or tritium, or the replacement of a carbon by a ¹³C- or ¹⁴C-enriched carbon or ¹⁵N-enriched nitrogen are within the scope of this invention.

The invention will be further illustrated by means of examples, which should not be interpreted as limiting the scope of the claims.

EXAMPLES

Example 1

General Procedure for the Formation of a Schiff Base-Type Ligand Catalyst

An aldehyde is refluxed in the presence of the corresponding diamine (2:1 molar ratio) in ethanol 95%. Filtration and further washing with absolute ethanol afforded the essentially pure Schiff base-type ligand.

The Schiff base-type ligand obtained above is refluxed in an alcoholic solution together with an aqueous solution of $\text{Co}(\text{OAc})_2 \cdot 4\text{H}_2\text{O}$ under inert atmosphere. Although a crystalline precipitate immediately appeared, refluxing continues for about an hour. The precipitate obtained is filtered under vacuum, washed with water, ethanol and ether, and then dried under vacuum.

Example 2

Immobilization of the Catalyst to a Solid Support

N,N'-(bis(3,5-di-tert-butyl-salicylidene)ethylenediamino)cobalt (II) [Co-tBu-Salen], 1.9 g, prepared following the procedure of Example 1, is added to 125 ml of 2-propanol with stirring, and the mixture heated to 70° C. Powdered silica (5g, Grace Davison XPO 2407, specific surface area 250 m²/g) is added to the solution and temperature and the stirring are maintained for a further 5 hours. The suspension is filtered, the solid residue is washed with 25 ml dichloromethane anhydrous, twice, and finally dried under vacuum for 5 hours.

Example 3

Comparative Example

A mixture of the aniline (13.2 mmol), the cobalt complex [Co-tBu-Salen] (0.25 mmol) prepared

following Example 1, NaI (2,72 mmol) and 1-butanol (20 ml) is charged in a 100 ml autoclave. The autoclave is flushed with carbon monoxide and oxygen in a volumetric ratio of 19/1 to a total pressure of 52.7 bar. The temperature is increased to 110° C. The reaction is maintained under constant vigorous stirring for three hours. After 3 hours the reactor is cooled to room temperature, depressurized and 97.8 g of 1,2-Dichlorobenzene (DCB) is charged in the reactor. The temperature is increased to 180° C. under atmospheric pressure. No 1-butanol is recovered by condensation of the vapours. Analysis of the reaction residue confirms the existence of urea derivatives but no traces of phenylisocyanate can be found.

Example 4

Synthesis of Phenylisocyanate

In a 1000 ml high-pressure stirred autoclave 15.5 g of aniline, 7.6 g of the [Co-tBu-Salen]/Silica catalyst of Example 2, 1.78 g of NaI and 488 g of 2,2,2-trifluoroethanol (TFE) are charged. The autoclave is pressurized with carbon monoxide and oxygen in a volumetric ratio of 19/1. The temperature is increased to 120° C. and the total pressure is maintained constant at 40 bars. The reaction is maintained under constant vigorous stirring for three hours. After 3 hours the reactor is cooled to room temperature, depressurized and 97.8 g of 1,2-dichlorobenzene (DCB) is charged in the reactor. The temperature is increased to 180° C. under atmospheric pressure. The vapors of TFE are separated, condensed, and reused in the following example. In the bottom of the reactor a mixture of DCB and phenylisocyanate is obtained. From this mixture phenylisocyanate is recovered by distillation with 99% w/w purity.

Yield of the intermediate carbamate was 94% and yield of the final isocyanate was 54.6% (51.3% overall yield).

Example 5

Synthesis of 2,4-toluendiisocyanate

In a 1000 ml high-pressure stirred autoclave 10 g of 2,4-toluendiamine (TDA), 7.6 g of [Co-tBu-Salen]/Silica catalyst of Example 2, 1.7 g of NaI and 484 g of 2,2,2-trifluoroethanol (TFE) are charged. The autoclave is pressurized with carbon monoxide and oxygen in a volumetric ratio of 19/1. The temperature is increased to 120° C. and the total pressure is maintained constant at 40 bars. The reaction is maintained under constant vigorous stirring for three hours. After 3 hours the reactor is cooled to room temperature, depressurized and 97.8 g of 1,2-dichlorobenzene (DCB) is charged in the reactor. Then the temperature is increased to 180° C. under atmospheric pressure. The vapors of TFE are separated, condensed, and reused in the following example. In the bottom of the reactor a mixture of DCB and 2,4-toluendiisocyanate is obtained. From this mixture 2,4-toluendiisocyanate is recovered by distillation with 99% w/w purity.

Yield of the intermediate carbamate was 84.1% and yield of the final isocyanate was 83%

(69.8% overall yield).

Example 6

Synthesis of 2,4-toluendiisocyanate

In a 350 ml high-pressure stirred autoclave 2 g of 2,4-toluendiamine (TDA), 0.37 g of N,N'-(bis(3,5-di-tert-butyl-salicylidene)ethylenediamino)cobalt (II) [Co-tBu-Salen], synthesized as described in Example 1, 0.18 g of NaI and 48.7 g of 2,2,2-trifluoroethanol (TFE) are charged. The autoclave is pressurized with carbon monoxide and oxygen in a volumetric ratio of 19/1. The temperature is increased to 120° C. and the total pressure is maintained constant at 40 bars. The reaction is maintained under constant vigorous stirring for three hours. After 3 hours the reactor is cooled to room temperature, depressurized and 97.8 g of 1,2-dichlorobenzene (DCB) is charged in the reactor. The temperature is increased to 180° C. under atmospheric pressure. The vapors of TFE are separated, condensed, and reused in the following example. In the bottom of the reactor a mixture of DCB and 2,4-toluendiisocyanate is obtained. From this mixture 2,4-toluendiisocyanate is recovered by distillation with 99% w/w purity.

Yield of the intermediate carbamate was 82% and yield of the final isocyanate was 78% (64% overall yield).

Example 7

Synthesis of 2,4-toluendiisocyanate

In a 350 ml high-pressure stirred autoclave 1 g of 2,4-toluendiamine (TDA), 0.2 g of (.-)-Trans-N,N'-bis(3,5-di-tert-butylsalicylidene)-1,2-cyclohexanediamine cobalt (II), synthesized as described in Example 1, 0.18 g of NaI and 48.9 g of 2,2,2-trifluoroethanol (TFE) are charged. The autoclave is pressurized with carbon monoxide and oxygen in a volumetric ratio of 19/1. The temperature is increased up to 120° C. and the total pressure is maintained constant at 40 bars. The reaction is maintained under constant vigorous stirring for three hours. After 3 hours the reactor is cooled to room temperature, depressurized and 97.8 g of 1,2-dichlorobenzene (DCB) is charged in the reactor. The temperature is increased to 180° C. under atmospheric pressure. The vapors of TFE are separated, condensed, and reused in the following example. In the bottom of the reactor a mixture of DCB and 2,4-toluendiisocyanate is obtained. From this mixture 2,4-toluendiisocyanate is recovered by distillation with 99% w/w purity.

Yield of the intermediate carbamate was 88.1% and yield of the final isocyanate was 62.4% (55% overall yield).

Other References

- Zhou, Xiang-Ge, et al., "Asymmetric epoxidation of alkenes catalysed by chromium binaphthyl Schiff base complex supported on MCM-41", "Chem. Commun.", 1999, pp. 1789-1790.
- Wan, Boshun, et al., "Polymer-supported palladium-manganese bimetallic catalyst for the oxidative carbonylation of amines to carbamate esters", "Applied Catalysis A: General", 1999, pp. 81-84, vol. 183.
- Toochinda, Pisanu, et al., "Carbamate and dicarbamate syntheses from CO/O₂/methanol/amines", "Chemical Ind.", 2003, pp. 369-378, vol. 89.
- Sutra, Pierre, et al., "Preparation of MCM-41 type silica-bound manganese(III) Schiff-base complexes", "Chem. Commun.", 1996, pp. 2485-2486.
- Shi, Feng, et al., "The first syntheses of diformamides by carbonylation of aliphatic diamines with Au(I) complex catalysts", "Chem. Commun.", 2001, pp. 345-346.
- Shi, Feng, et al., "Silica-gel-confined ionic liquids: a new attempt for the development of supported nanoliquid catalysis", "Chem. Eur. J.", 2005, pp. 5279-5288, vol. 11, No. 18.
- Shi, Feng, et al., "Polymer-immobilized gold catalysts for the efficient and clean syntheses of carbamates and symmetric ureas by . . .", "Journal of Catalysis", 2002, pp. 548-551, vol. 211.
- Shi, Feng, et al., "A Novel PdCl₂/ZrO₂/SO₂-4 Catalyst for Synthesis of Carbamates by Oxidative Carbonylation of Amines", 2001.
- Selva, Maurizio, et al., "The synthesis of alkyl carbamates from primary aliphatic amines and dialkyl carbonates in supercritical carbon dioxide", "Tetrahedron Letters", 2002, pp. 1217-1219, vol. 43.
- Riess, Jean G., et al., "Solubility and transport phenomena in perfluorochemicals relevant to blood substitution and other biomedical application", "Pure and Appl. Chem.", 1982, pp. 2383-2406, vol. 54, No. 12.
- Prasad, K. Venkatesh, et al., "Activity and selectivity of supported Rh catalysts for oxidative carbonylation of aniline", "Journal of Catalysis", 1994, pp. 204-215, vol. 145.
- Peng, Xingao, et al., "A highly efficient sulfur-catalyzed oxidative carbonylation of primary amines and beta-amino alcohols", "Synlett", 2006, pp. 1161-1164, No. 8.
- Orejon, Aranzazu, et al., "Oxidative carbonylation of aniline with new cobalt catalytic systems", "Can. J. Chem.", 2005, pp. 764-768, vol. 83.
- Miyazawa, Masahiro, et al., "Palladium-complex-catalyzed decarboxylation-carbonylation of allyl diethylcarbamates", "Synlett", Apr. 1992, pp. 323-324, No. 4.
- Maddinelli, Giuseppe, et al., "The bis(salicylaldehyde)ethylenediimine cobalt(II)-catalyzed oxidative carbonylation of 1-adamantylamine in alcohol . . .", "Journal of Molecular Catalysis", 1987, pp. 71-77, vol. 39.
- Li, Kuo-Tseng, et al., "Oxidative carbonylation of aniline using manganese-based catalysts", "Journal of Catalysis", 1993, pp. 631-634, vol. 143.
- Leung, Tak W., et al., "Oxidative carbonylation of amines catalysed by metallomacrocyclic compounds", "J. Chem. Soc. Chem. Commun.", 1992, pp. 205-206, No. 3.
- Kim, Hoon Sik, et al., "Oxidative carbonylation of aromatic amines by selenium compounds", "Journal of Catalysis", 1999, pp. 526-534, vol. 184.

- Khan, M. M. Taqui, et al., "Oxidative carbonylation of cyclohexylamine to cyclohexylurethane catalysed by dichlorobis(salicylaldehyde)-o- . . .", "Journal of Molecular Catalysis", 1990, pp. 303-309, vol. 59.
- Kelkar, Ashutosh, et al., "Selectivity behavior in catalytic oxidative carbonylation of alkylamines", "Ind. Eng. Chem. Res.", 1992, pp. 172-176, vol. 31.
- Gupte, Sunil P., et al., "Oxidative carbonylation of aniline over Pd/C catalyst: effect of promoters, solvents and reaction conditions", "Journal of Catalysis", 1988, pp. 246-258, vol. 114.
- Dias, A. M. A., et al., "Solubility of oxygen in liquid perfluorocarbons", "Fluid Phase Equilibria", 2004, pp. 325-330, vol. 222-223.
- Corriu, Robert J. P., et al., "Ordered mesoporous hybrid materials containing cobalt(II) Schiff base complex", 2002, pp. 1355-1362, vol. 12.
- Choudary, B. M., et al., "Syntheses of interlamellar montmorillonitebipyridinepalladium(II) catalysts: the first examples of chelation in . . .", "J. Chem. Soc., Chem. Commun.", 1987, pp. 1505-1506.
- Chisem, Ian C., et al., "Catalytic oxidative of alkyl aromatics using a novel silica supported Schiff base complex", "Chem. Commun.", 1998, pp. 1949-1950.
- Chen, Bei, et al., "CuCl₂ and PdCl₂ catalysts for oxidative carbonylation of aniline with methanol", "Journal of Molecular Catalysis", 2003, pp. 37-45, vol. 195.
- Bolzacchini, Ezio, et al., "Substituent effects in the cobalt-catalyzed oxidative carbonylation of aromatic amines", "Journal of Molecular Catalysis", 1996, pp. 281-287, vol. 111.
- Bassoli, Angela, et al., "Acyclic and cyclic urea formation via the cobalt-catalysed oxidative carbonylation of aromatic primary amines", "Journal of Molecular Catalysis", 1990, pp. 41-48, vol. 60.
- Alper, Howard, et al., "An exceptionally mild, catalytic homogeneous method for the conversion of amines into carbamate esters", "J. Chem. Soc., Chem. Commun.", 1985, pp. 1141-1142.
- Bolzacchini et al., Journal of Molecular Catalysis A: Chemical 111 (1996) 281-287.

Inventors

- Serrano Fernandez, Francisco Luis
- Almena Munoz, Beatriz
- Padilla Polo, Ana
- Orejon Alvarez, Arancha
- Claver Cabrero, Carmen
- Castillon Miranda, Sergio
- Salagre Carnero, Pilar
- Aghmiz, Ali

Assignee

- REPSOL-YPF,S.A.

Application

No. 11765449 filed on 06/20/2007

US Classes:

560/341Carbon monoxide utilized

Examiners

Primary: Puttlitz, Karl

Attorney, Agent or Firm

- Hultquist; Steven J.
- Intellectual Property / Technology Law

US Patent References

5194660Processes for producing carbamates and isocyanates

Issued on: 03/16/1993

Inventor: Leung, et al.

Foreign Patent References

- 2004262835 JP 09/01/2004
- 9856758 WO 12/01/1998
- 9947493 WO 09/01/1999

International Class

C07C 263/00

Appendix 7: US Patent 4582923 - Process for the Production of Urethanes

US Patent – 4582923 - Process for the production of urethanes

Inventor: Stammann, et al. **Date Issued:** April 15, 1986 **Application:** 06/735,249 **Filed:** May 17, 1985 **Inventors:** Becker; Robert (Leverkusen, DE)

Grolig; Johann (Leverkusen, DE)

Stammann; Gunter (Cologne, DE)

Waldmann; Helmut (Leverkusen, DE)

Assignee: Bayer Aktiengesellschaft (Leverkusen, DE) **Primary Examiner:** Helfin; Bernard

Assistant Examiner: Attorney Or Agent: Harsh; GeneGil; Joseph C. Whalen; Lyndanne M. U.S.

Class: 546/159; 546/309; 548/163; 548/557; 548/558; 549/480; 549/69; 560/115; 560/13; 560/157; 560/158; 560/162; 560/163; 560/22; 560/24; 560/25; 560/29; 560/30 **Field Of Search:**

560/24; 560/25; 560/32; 560/163; 560/157; 560/162; 560/158; 560/115; 560/30; 560/29;

560/22; 560/13; 546/309; 546/159; 548/557; 548/558; 548/163; 549/480; 549/69; 260/465.4

International Class: U.S Patent Documents: 3641092; 4236016; 4251667; 4260781; 4266070;

4267353; 4297501; 4319035 **Foreign Patent Documents:** 2910132 **Other References:**

Abstract: Urethanes are made by reacting a primary amine with carbon monoxide and a compound containing at least one hydroxyl group in the presence of an oxidizing agent and a catalyst system. The catalyst system is made up of (i) a noble metal and/or a noble metal compound of a metal of the Eighth Secondary Group of the Periodic System of Elements and (ii) an oxidizing quinoid and/or a compound capable of being converted to an oxidizing quinoid compound under the reaction conditions. The catalyst system may optionally include (iii) metal compounds of elements of the Third to Fifth Main Groups and/or First to Eighth Secondary Groups of the Periodic System of Elements and/or (iv) a tertiary amine. This reaction is generally carried out at a temperature of from 100.degree. to 300.degree. C. and at a pressure of from 5 to 500 bars. The product urethanes are useful in the production of isocyanates and pesticides. **Claim:** What is claimed is:

1. A process for the production of a urethane by reacting a primary amine with carbon monoxide and a compound containing at least one hydroxyl group in the presence of from 60 to 500% of the stoichiometric amount of oxygen necessary to react with the amino groups to be reacted and a catalyst system, said catalyst system comprising:

(a) palladium, a palladium compound or a mixture thereof; and

(b) an oxidizing quinoid, a compound capable of being converted to an oxidizing quinoid compound under the reaction conditions, or a mixture thereof in an amount of from 0.1 to 5 wt % (based on total weight of reaction mixture).

2. The process of claim 1 wherein the catalyst system further comprises a compound of an

element selected from the Third to Fifth Main Groups and/or First to Eighth Secondary Group of the Periodic System of Elements which compound is capable of undergoing a redox reaction under the reaction conditions.

3. The process of claim 1 wherein the catalyst system further comprises a tertiary amine.
4. The process of claim 1 wherein component (a) of the catalyst system is present in an amount which is from 5 ppm to 100 ppm expressed as noble metal and based on the total weight of the reaction mixture.
5. The process of claim 1 wherein the catalyst system further comprises up to 0.1 wt. % (based on the total weight of the reaction mixture) of a compound of an element selected from the Third to Fifth Main Group and/or First to Eighth Secondary Group of the Periodic System of Elements which compound is capable of undergoing a redox reaction under the reaction conditions.
6. The process of claim 5 wherein the catalyst system further comprises up to 10 wt. % (based on the total weight of the reaction mixture) of a tertiary amine.
7. The process of claim 1 wherein the reaction is carried out at a temperature in the range from 100.degree. to 250.degree. C. and under a pressure of from 5 to 500 bars.
8. The process of claim 1 wherein the reaction is carried out in the presence of up to 80 wt. % (based on the total weight of the reaction mixture) of an inert solvent.
9. The process of claim 1 wherein the product urethane is separated from the catalyst system and any remaining oxidizing agent or reduced oxidizing agent by distillation and/or filtration.
10. The process of claim 9 wherein the separated catalyst system is reused in a subsequent reaction.
11. The process of claim 1 in which the reaction is carried out in the presence from 100 to 500% of the stoichiometric amount of oxygen necessary to react with the amino groups to be reacted. **Description:** BACKGROUND OF THE INVENTION

This invention relates to a process for the production of urethanes (carbamic acid esters or carbamates). More specifically, it relates to a process in which primary amines are reacted with organic hydroxyl compounds and carbon monoxide in the presence of an oxidizing agent and in the presence of a catalyst system. The catalyst system includes at least one noble metal or at least one noble metal compound, and a quinoid compound or compound capable of being converted into a quinoid compound.

Generally, organic isocyanates are commercially produced by reacting the corresponding amine with phosgene. However, due to the high chlorine demand and the high energy costs involved in

the production of phosgene, considerable efforts have been exerted to find a commercially workable method for producing organic isocyanates in which there is no need to use phosgene. In one such method, primary amines are reacted with carbon monoxide, organic hydroxyl compounds and an oxidizing agent (such as air or an organic nitro compound) to form the corresponding urethanes; the urethanes thus formed are then split into isocyanates and compounds containing hydroxyl groups. This phosgene-free process for producing urethanes is described in German Offenlegungsschrift No. 2,910,132 and in German Offenlegungsschrift No. 2,908,251 (.dbd.EP-OS No. 16346 or U.S. Ser. No. 125,394 filed Feb. 27, 1980). In the process described in German Offenlegungsschrift No. 2,908,251, primary amines are catalytically oxycarbonylated by reaction with carbon monoxide, organic hydroxyl compounds, an oxidizing agent which is either molecular oxygen or a nitro compound and a catalyst. The disclosed catalyst is, from 1 to 5 weight % (based on the mixture as a whole,) of chloride-containing, inorganic solids which are largely insoluble in the reaction mixture used in combination with a noble metal catalyst. This latter process, however, is disadvantageous in that the high content of chloride-containing compounds causes corrosion problems in the process apparatus. Additionally, the fact that the inorganic catalyst components are substantially insoluble seriously affects the commercial practicability of the known process.

SUMMARY OF THE INVENTION

It is an object of the present invention to provide a process for the production of urethanes from primary amines.

It is another object of the present invention to provide a process for the production of urethanes from primary amines which does not require the use of phosgene.

It is also an object of the present invention to provide a process for the production of urethanes from primary amines in which insoluble and/or corrosive catalysts need not be used.

These and other objects which will be apparent to those skilled in the art are accomplished by reacting a primary amine with carbon monoxide and a compound having at least one hydroxyl group in the presence of an oxidizing agent and a catalyst system. A suitable catalyst system includes a noble metal and/or noble metal compound of Group VIII b of the Periodic System of Elements and an oxidizing quinoid compound and/or a compound capable of being converted to an oxidizing quinoid compound under the reaction conditions.

DETAILED DESCRIPTION OF THE INVENTION

The present invention relates to a process for the production of urethanes in which primary amines are reacted with carbon monoxide and compounds containing at least one hydroxyl group in the presence of oxidizing agents and a catalyst system. Appropriate catalyst systems contain at least one noble metal and/or noble metal compound from the Eighth Secondary Group of the Periodic System of Elements, and at least one oxidizing quinoid compound and/or at least one compound which may be converted under the reaction conditions into an oxidizing

quinoid compound.

Primary amines which may be used in the practice of the present invention are any organic compounds containing at least one primary amino group, particularly primary amines containing at least one aliphatically, cycloaliphatically, aromatically or heterocyclically bound amino group which amines may optionally contain other functional groups. It is preferred to use aromatic or aliphatic monoamines or diamines, particularly monoamines which do not contain any oxidizable substituents other than the primary amino groups. The amines used in the practice of the present invention generally have a molecular weight in the range from 31 to 3000, preferably in the range from 31 to 400 and most preferably in the range from 31 to 200.

Examples of suitable aromatic and heterocyclic amines include aniline, 1,2-diaminobenzene, 1,4-diaminobenzene, the isomeric chloroanilines, 3,4-dichloroaniline, 4-isopropyl aniline, p-toluidine, chlorotoluidines, xylydines, alkoxy anilines, 4-pentachloroethyl aniline, 2-nitroaniline, 3-nitroaniline, 4-nitroaniline, 2,3-diaminotoluene, 2,4-diaminotoluene, 2,6-diaminotoluene, 2,5-diaminotoluene, 3,4-diaminotoluene, 3,5-diaminotoluene, 2-amino-4-nitrotoluene, 2-amino-3-nitrotoluene, 2-amino-5-nitrotoluene, aminophenols, diaminoxylenes, aminonitroxylenes, aminonaphthalenes, aminoanthracenes, chloroaminobenzoic acids, chloroaminobenzoic acid esters, aminobenzene sulfonic acids, 4,4'-diaminodiphenylmethane, 2,2'-diaminodiphenylmethane, 2,4-diaminodiphenylmethane, tris-(4-aminophenyl)-methane, aminopyridines, aminoquinolines, aminopyrroles, aminofurans, aminothiophenes and 2-aminobenzothiazole.

Examples of suitable cycloaliphatic primary amines are aminocyclobutane, aminocyclopentane, cyclohexylamine, 1,2-diaminocyclohexane, 1,3-diaminocyclohexane, 1,4-diaminocyclohexane, bis-(aminocyclohexyl)-methanes and tris-(aminocyclohexyl)-methanes.

Examples of appropriate aliphatic primary amines include: methylamine, ethylamine, 1-propylamine, 2-propylamine, 1-butylamine, 2-butylamine, isobutylamine, tert.-butylamine, 1-pentylamine, 1-hexylamine, 1-heptylamine, 1-octylamine, 1-decylamine, 1-dodecylamine, ethylene diamine, 1,2-diamino-propane, 1,3-diaminopropane, diaminobutanes, diaminopentanes, diaminohexanes, diaminooctanes, diaminodecanes, benzylamine, bis-(aminomethyl)-cyclohexanes, bis-(aminomethyl)-benzene, .omega.-aminocarboxylic acid esters, and .omega.-aminocarboxylic acid nitriles.

Particularly preferred primary amines are aromatic primary amines, such as aniline, substituted anilines, the isomeric diaminotoluenes and 4,4'-diaminodiphenyl methane.

Organic compounds containing hydroxyl groups which may be used in the practice of the present invention are any organic compounds which contain at least one alcoholically or phenolically bound hydroxyl group and which have a molecular weight in the range from 32 to 2000 (preferably in the range from 32 to 300). Alcohols are the preferred hydroxy materials.

Suitable alcohols include: any linear or branched monohydric or polyhydric alkanols or alkenols,

any monohydric or polyhydric cycloalkanols, cycloalkenols and aralkanols. Any alcohols containing inert substituents such as halogen atoms, sulfoxide groups, sulfone groups, carbonyl or carboxylic acid ester groups may also be used. Alcohols containing ether bridges are also suitable for the practice of the present invention. Examples of appropriate alcohols are: methanol, ethanol, n-propanol, isopropanol, n-butanol, n-pentanol, n-hexanol, cyclohexanol, benzyl alcohol, chloroethanol, ethylene glycol, diethylene glycol, propylene glycol, dipropylene glycol, glycerol, hexane triol and trimethylol propane.

If an alcohol having a hydroxyl functionality greater than one is used, a monobasic amine should be used as the starting component in the process of the present invention. Conversely, if higher functionality amines are used, a monofunctional hydroxyl compound should be used as a reactant. Monohydric aliphatic alcohols containing from 1 to 6 carbon atoms are the preferred hydroxyl reactants in the process of the present invention.

Phenols suitable for the practice of the present invention are those having a molecular weight in the range from 94 to 600, preferably in the range from 94 to 300. Examples of such phenols include: phenol, .alpha.-naphthol, .beta.-naphthol, anthranol, phenanthrol, hydroxybenzofurans and hydroxy quinolines. Polyhydric phenols such as dihydroxybenzenes, dihydroxy naphthalenes, 4,4'-dihydroxy diphenylmethane, bisphenol A, pyrogallol and phloroglucinol may also be used. Any of the above-mentioned phenols containing inert substituents such as halogen atoms, sulfoxide groups, sulfone groups, carboxyl or carboxylic acid ester groups, nitro groups, alkyl groups, aryl groups, alkoxy groups and aroxy groups are also suitable. Particularly preferred phenols are phenol, the isomeric chlorophenols, bisphenol A, 2-isopropoxy phenol and 7-hydroxy-2,2-dimethyl-2,3-dihydrobenzofuran.

In practicing the process of the present invention, the organic compounds containing hydroxyl groups should generally be used in quantities such that from 1 to 200 mols and preferably from 1 to 50 mols of hydroxyl groups are present for each mol of primary amino group present in the reaction mixture. Since hydroxyl compounds which are liquid under the reaction conditions are generally used as reactants, when used in excess amounts these compounds may serve as the reaction medium (solvent) for the process according to the invention.

The carbon monoxide is generally used in a quantity such that between 1 and 30 mols of carbon monoxide are present for each mol of urethane to be produced, i.e. from 1 to 30 mols of carbon monoxide are generally used for each mol of primary aminogroups present in the reaction mixture.

Molecular oxygen in pure form or in the form of a mixture with an inert gas (e.g. nitrogen or carbon dioxide) such as air, may be used as the oxidizing agent in the process of the present invention. In the presence of molecular oxygen, the oxycarbonylation reaction takes place in accordance with the following general equation:

It is readily seen from this equation that 1 mol of carbon monoxide and 1/2 mol of oxygen are required for each urethane group formed. In general, molecular oxygen may be used in an

amount ranging from a substantially stoichiometric quantity to a 5-fold excess (based on the amino groups to be reacted). However, where alcohols sensitive to oxidizing agents are used as reactants, it may be advisable to use the oxidizing agent (particularly oxygen) in a sub-stoichiometric quantity (based on the amino groups to be reacted), i.e. in a quantity which corresponds to between 60 and 100% of the equivalent quantity required in accordance with the above equation. Use of less than stoichiometric quantities when oxidation-sensitive alcohols are used is advantageous because the decrease in yield of urethane attributable to undesirable oxidation reactions may be greater than the decrease which occurs when substoichiometric quantities of oxidizing agent are used. In addition, where a sub-stoichiometric quantity of oxidizing agent, particularly oxygen, is used the reaction mixture will contain readily recoverable starting amine which may be re-used in a subsequent reaction. However, when excess oxidizing agent is present in a reaction mixture containing such an oxidation-sensitive alcohol, the alcohol will be destroyed by undesirable oxidation reactions and cannot be recovered.

In addition to oxygen, other suitable oxidizing agents include any oxidizing, inorganic, largely ionic compounds (particularly salt-like compounds) of metals in relatively high valency stages which metals may have several valency stages. The nature of the anions in these compounds is not important. Appropriate anionic groups are chloride, bromide, hydroxide, sulfate, hydrogen sulfate, phosphate, nitrate and carbonate anions. These anions may be present singly or in combination with one another or in combination with oxyanions (i.e. anions in which oxygen is present). Similarly, organic counterions, for example carboxylate, sulfonate, phosphonate, alcoholate and phenolate ions may also be present as anions.

The largely ionic compounds of metals having atomic numbers 22 to 29, 42, 47, 50, 51, 58, 74, 80 to 83 and 92 in high positive valency stages are particularly preferred inorganic oxidizing agents. Where inorganic oxidizing agents of this type are used, it is desirable to select one which has a minimal corrosive effect and a certain solubility in the reaction mixture. Both the corrosion behavior and the solubility of the inorganic oxidizing agent may be favorably influenced by formation of a complex of the oxidizing agent with the mixture of starting materials containing amino groups and/or with the organic constituents of the catalyst system.

Where a largely ionic inorganic oxidizing agent is used, the oxycarbonylation reaction takes place in accordance with the following general equation: $M^{n+} + R_2NH + CO \rightarrow M^{n-a+} + R_2NCO$ In this equation, M^{n+} is a metal having an " n^{+} " oxidation state. In the oxycarbonylation reaction, this metal takes up " a " electrons. Where these largely ionic inorganic oxidizing agents are the only oxidizing agents used, they are generally employed in quantities such that from $2/a$ to $10/a$ gram equivalents (preferably from $2/a$ to $3/a$ gram equivalents) of oxidizing inorganic compound are available in the reaction mixture for each mol of primary amino groups.

Other oxidizing agents suitable to the practice of the present invention are quinoid organic compounds which, by virtue of their oxidation potential, are capable of oxidizing the amine under the reaction conditions. Quinoid organic compounds of this type include quinones, such as o-benzoquinone, p-benzoquinone, naphthoquinones, and anthraquinones in substituted or

unsubstituted form. Suitable substituents are electron-attracting groups which increase the oxidation potential of the quinoid compound, such as carboxylic acid, sulfonic acid, cyano groups and halogen substituents either individually or in combination with one another. Where these quinoid oxidizing agents are exclusively used, they should generally be employed in quantities such that at least one mol of quinoid structural units (i.e. where p-benzoquinone is used, at least one mol of this quinone) is available for every mol of primary amino groups. In addition to these quinones, the quinoid compounds described hereinafter as suitable co-catalysts may also be used as the quinoid compounds.

Where quinoid oxidizing agents are used in the oxycarbonylation of the primary amines in accordance with the present invention, the reaction takes place as exemplified with the following equation: ##STR1##

Where these quinoid oxidizing agents are used in the process of the present invention, they should preferably be employed in quantities ranging from the stoichiometric quantity corresponding to the above reaction equation to approximately 5 times the stoichiometric quantity and most preferably between 1 and 1.5 times the stoichiometric quantity. Where several of the above-described oxidizing agents are simultaneously used, the quantity in which each is used may of course be reduced accordingly. Where the ionic and/or quinoid oxidizing agents described above are exclusively used, any oxidation-sensitive alcohols present are less likely to be destroyed by oxidation than where molecular oxygen is used. Accordingly, the ionic and/or quinoid oxidizing agents should not generally be used in substoichiometric quantities because this would only result in decreased yield.

The process of the present invention is carried out in the presence of a catalyst system. Such a catalyst system contains (i) at least one noble metal and/or at least one noble metal compound of the Eighth Secondary Group of the Periodic System of Elements and (ii) at least one oxidizing quinoid compound and/or at least one compound which is capable of being converted into an oxidizing quinoid compound under the reaction conditions.

Catalyst component (i) may be either a free noble metal of the Eighth Secondary Group of the Periodic System or a compound of one of these metals. These noble metals are particularly advantageous when used in the form of compounds soluble in the reaction mixture, such as chlorides, bromides, iodides, chlorocomplexes, bromocomplexes, iodocomplexes, acetates, acetyl acetonates and other soluble noble metal compounds. Preferred noble metals are palladium, ruthenium and rhodium. It is particularly preferred to use palladium, particularly in the form of soluble palladium chloride or palladium acetate.

Preferred concentrations for the catalyst component (i) are generally in the range from 3 to 1000 ppm and most preferably in the range from 5 to 100 ppm, expressed as noble metal and based on the reaction mixture as a whole, including any solvent used. Although higher concentrations of noble metal may be used, such excess is uneconomical and does not further increase the yield of urethane.

Catalyst component (ii) is an oxidizing quinoid compound and/or a compound which is capable of being converted into an oxidizing quinoid compound under the reaction conditions. Quinoid compounds are compounds of the type described for example in "The Chemistry of the Quinoid Compounds", Part I and II (London, Wiley 1974, Editor: Patai) and frequently manufactured as dyes or dye precursors. In principle, catalyst component (ii) may be any quinoid compound of the type capable of oxidizing thenoble metal present in catalyst component (i) from the zero oxidation state to a positive oxidation state under the reaction conditions. Those quinoids which are capable of converting palladium, from the oxidation stage zero to the oxidation stage +2 are particularly preferred.

In addition to the above-described quinoid compounds, compounds capable of being converted into such quinoid compounds, i.e. compounds which may be converted into a quinoid compound by an oxidation reaction (e.g. by the oxidizing agent used in the process of the present invention) by solvolysis or by an elimination reaction, may also be used as catalyst component (ii).

Suitable quinoid catalyst components (ii) are ortho- and para-quinones, polynuclear quinones and heterocyclic quinones in substituted and unsubstituted form and also their imino, N-alkyl- or N-aryl-imino derivatives. Specific examples of such compounds are: o-tetrachlorobenzoquinone, p-tetrachlorobenzoquinone, 2,5-dichloro-3,6-dihydroxy-p-benzoquinone, 2-chlorophenyl-1,4-benzoquinone, 2,3-dichloronaphthoquinone, anthraquinone, 1-chloroanthraquinone, 7-chloro-4-hydroxy-1,10-anthraquinone, 1-nitroanthraquinone-2-carboxylic acid, 1,5-dichloroanthraquinone, 1,8-dichloroanthraquinone, 2,6-dichloroanthraquinone, 1,4-dihydroxy anthraquinone, acenaphthylene dione, 5,7-dichloro-1H-indol-2,3-dione, indigo or 1,4-dihydro-2,3-quinoxaline dione.

Polymeric quinoid compounds of the type described for example by H. G. Cassidy and K. A. Kun in "Oxidation-Reduction Polymers" (Polymer Reviews Vol. 11, Interscience Publ. New York 1965), are also suitable for use as catalyst component (ii).

Preferred quinoid compounds are those substituted by one or more electron-attracting substituents, such as chlorine, bromine, cyano, nitro, carboxylic acid or sulfonic acid groups. Such substituents increase the oxidation potential of the quinoid compound. Quinoid compounds which are particularly preferred as catalyst component (ii) are o-tetrachlorobenzoquinone, p-tetrachlorobenzoquinone, 2,5-dichloro-3,6-dihydroxy-p-benzoquinone, 2,3-dichloronaphthoquinone, 7-chloro-4-hydroxy-1,10-anthraquinone, 1,5-dichloroanthraquinone and 1,8-dichloroanthraquinone.

Compounds which are readily converted to quinoid compounds suitable for use as catalyst component (ii) are, for example, ketals of the corresponding quinoid and also hydrogenated forms of those components, particularly the corresponding hydroquinones. Aromatic amines and polynuclear aromatic compounds which are substituted by sulfonic acid, carboxylic acid, nitro or cyano groups or which already contain an oxy group in the ring system may be converted into quinoid catalyst component (ii) under the reaction conditions (e.g. by molecular

oxygen). Compounds which are readily converted to a quinoid which may be used as catalyst component (ii) in the present invention are the hydroquinones and ketals of the above-mentioned quinones, 4-amino-2-(phenyl-amino)-benzene sulfonic acid, 5-amino-2-((4-chlorophenyl)-amino)-benzene sulfonic acid, 4,4'-diamino-(1,1'-biphenyl)-3,3'-disulfonic acid, 2-aminobenzene sulfonic acid and benzanthrone-3-carbonitrile.

The catalyst component (ii) should generally be added to the reaction system in a concentration from 0.1 wt. % to 5 wt. % and preferably in concentrations of from 0.5 to 3 wt. % (based on the total quantity of reaction mixture including any solvent used).

The quinoid compounds are capable of performing the dual function of oxidizing agent and catalyst component (ii). When used in this dual capacity, it is necessary to use larger quantities of the quinoid compound than specified above for quinoids used only as an oxidizing agent.

The catalyst component of the present invention may optionally contain certain metal compounds (iii) and/or tertiary amines (iv) as further components.

The optional catalyst component (iii) may be a magnesium compound, particularly an inorganic or an organic salt of magnesium, or a compound of an element of the Third to Fifth Main Group and/or First to Eighth Secondary Group of the Periodic System of Elements which is capable of undergoing a redox reaction under the reaction conditions. Compounds of metals with the atomic numbers 12, 22 to 29, 41, 47, 58 and 92 which are at least partly soluble in the reaction mixture are preferably used as the optional catalyst component (iii). The most preferred catalyst components (iii) are the acetates, nitrates and chlorides of chromium, manganese, cobalt, copper, cerium or magnesium, which may be in the form of the hydrates or amine complexes of these metal salts. In conjunction with activating chlorides, (e.g. ammonium chlorides) it is also possible to use the oxides of these metals as catalyst component (iii). If catalyst component (iii) is used, it should generally be employed in an amount which is from one to ten times the required molar quantity (based on catalyst component (i)). In general, this means that catalyst component (iii) may be used in quantities of up to 0.1 wt. % (based on the total weight of the reaction mixture including any solvent used).

The optional catalyst component (iv) may be any tertiary amine which, in the catalyst system, performs the function of a complexing agent for the oxidized form of catalyst component (i). It is particularly advantageous to use a tertiary amine which is also capable of forming a complex with component (iii) in case the complexing effect of the starting compounds present in the reaction mixture is inadequate for this purpose. In principle, any tertiary amines, i.e. tertiary amines of the type containing aliphatically, cycloaliphatically, araliphatically and/or aromatically bound tertiary amino groups or tertiary amino groups forming part of a heterocyclic ring may be used in the practice of the present invention. Suitable tertiary amines are, for example, triethyl amine, diisopropyl methyl amine, cyclohexyl diethyl amine, triphenyl amine, N,N-diethyl aniline, N-phenyl piperidine, pyridine, quinoline, 1,4-diaza-(2,2,2)-bicyclooctane and pyrimidine. Preferred tertiary amines (iv) are triethyl amine, N,N-diethyl aniline and pyridine. The above-mentioned tertiary amines may also be used in the form of metal salt complexes of catalyst

component (i) and optionally (iii). If catalyst component (i) and/or optionally (iii) is used in the oxide form, it is advantageous to use the tertiary amines in the form of hydrochlorides for the purpose of activating this (these) component(s). The optional catalyst component (iv) should be used in quantities of up to 10 wt. %, preferably from 0.5 to 6 wt. % (based on the total quantity of reaction mixture including any solvent used). However, catalyst component (iv) may be used in larger quantities.

The process of the present invention may be carried out in the presence or absence of a solvent. In general, the reactant organic hydroxyl compound preferably used in excess serves as solvent. However, it is also possible to use inert solvents which may make up as much as 80 wt. % of the total reaction mixture. The quantity of solvent used, whether the hydroxyl compound used in excess or an inert solvent, should be such that the heat of reaction of the exothermic urethane-forming reaction may be dissipated without any unacceptable increase in temperature. In general, therefore, the process according to the invention is carried out using a concentration of amino compounds of from 5 to 50 wt. % and preferably from 5 to 20 wt. % (based on the total reaction mixture including the solvent).

Suitable solvents are solvents which are inert both to the reaction components and to the catalyst system. Such solvents include aromatic, cycloaliphatic and aliphatic hydrocarbons which may optionally be halogen-substituted, such as benzene, toluene, xylene, chlorobenzene, dichlorobenzene, trichlorobenzene, chloronaphthalene, cyclohexane, methyl cyclohexane, chlorocyclohexane, methylene chloride, carbon tetrachloride, tetrachloroethane, trichlorotrifluoroethane and similar compounds as well as tertiary amines of the type described as catalyst component (iv).

The reaction temperature should generally be in the range from 100 to about 300.degree. C., preferably in the range from 100 to 250.degree. C. and most preferably in the range from 140 to 220.degree. C. The pressure should be such that the presence of a liquid phase is guaranteed. This pressure is generally in the range from 5 to 500 bars and preferably in the range from 30 to 300 bars.

Depending upon the primary amine and hydroxy compound used, the reaction time required for a quantitative reaction ranges from a few minutes to several hours.

The process according to the invention may be carried out continuously or in batches. It is advantageous to use a solvent in which the end product (urethane) is highly soluble. After the reaction medium has been relieved of pressure and cooled to between 50.degree. and 80.degree. C., catalyst components (i), (ii), (iii) and, in complexed form (iv) (if it has been used) are substantially or completely precipitated in numerous solvents. In some cases, it is advantageous to concentrate the reaction mixture to between 70 and 50% of its original volume to precipitate the catalyst mixture. The catalyst mixture may then be separated off from the urethane-containing solution by filtration or centrifugation. The thus-recovered catalyst components (i), (ii), (iii) and, optionally, (iv) may be recycled in most cases even though they may be chemically modified. The urethane may be separated from the filtrate by

techniques known to those in the art such as evaporating the solvent. The product urethane may be purified for example by vacuum distillation or by crystallization. The product urethane may be similarly treated where salt-like inorganic oxidizing agents or quinone-like oxidizing agents are used. The oxidizing agent obtained in reduced form after the reaction has been completed contains substantial amounts of catalyst components (i), (ii) and (iii). This oxidizing agent may be reoxidized and recycled along with these catalyst components to the reaction chamber.

The end products (urethanes) of the present invention are suitable for use as pesticides or as intermediate products in the production of pesticides. However, these urethanes are of primary interest as starting materials for producing the isocyanates on which they are based. Production of such isocyanates is carried out in known manner by thermal dissociation of the urethanes of the present invention.

The process according to the invention is illustrated by the following Examples although this invention is in no way limited to the conditions disclosed in these Examples. The urethane yields are based in each case on the amine used and are given in terms of mol percent.

EXAMPLES

EXAMPLE 1

(Comparison Example: No catalyst component (ii))

474 g of a mixture having the following composition were introduced into an enamelled 1.3-liter fine-steel autoclave: 42 ppm of palladium acetate, 211 ppm of copper (II) acetate monohydrate, 91.4 wt. % ethanol and 8.6 wt. % aniline. 100 bars of carbon monoxide and 25 bars of air were then introduced into the autoclave at room temperature. The contents of the autoclave were then heated with stirring to 180.degree. C. and left to react for 1 hour at that temperature. After cooling to room temperature, the autoclave was vented and a second similar reaction phase was carried out with a fresh CO/air mixture. A total of approximately 1.4 oxidation equivalents (based on aniline) were introduced in the form of atmospheric oxygen. Analysis of the liquid reaction mixture by gas chromatography showed that the yield of phenyl urethane was 4.5 mol %, based on the aniline used.

EXAMPLES 2 TO 9

These Examples demonstrate the catalytic activity of catalyst component (ii). In Examples 2 to 6, catalyst component (ii) was a quinoid compound and in Examples 7 to 9, it was the preliminary state of a quinoid compound. The procedure was the same as that described in Example 1, with the exception that 483 g of a mixture of the following composition was used: 41 ppm of palladium acetate, 207 ppm of copper (II) acetate monohydrate, 1.8 wt. % catalyst component (ii), 89.8 wt. % ethanol and 8.4 wt. % aniline. The results are set out in Table 1.

TABLE 1	Yield of phenyl urethane in Example No.	
Catalyst component (ii) mol %		
2 ortho-tetrachlorobenzoquinone	46.0	3
3 para-tetrachlorobenzoquinone	64.0	4
4 2,5-dichloro-3,6-dihydroxy-	47.5	5
5 para-benzoquinone	52.5	6
6 1,5-dichloroanthraquinone	40.9	7
7 benzanthrone-3-carbonitrile	27.1	8
8 5-amino-2-(phenylamino)-	29.0	9
9 benzene sulfonic acid	32.0	10
10 4,4'-diamino-(1,1'-biphenyl)-		
11 3,3'-disulfonic acid		

EXAMPLE 10

The procedure was the same as that described in Example 1 with the exception that 487 g of a mixture of the following composition were used: 41 ppm of palladium acetate, 206 ppm of copper (II) acetate monohydrate, 1.7 wt. % p-tetrachlorobenzoquinone, 0.8 wt. % N,N-diethylaniline, 89.0 wt. % ethanol and 8.4 wt. % aniline. Yield of phenyl urethane: 72.6 mol %.

EXAMPLE 11

The procedure was the same as that described in Example 1 with the exception that 483 g of a mixture of the following composition were used: 41 ppm of palladium acetate, 207 ppm of copper (II) acetate monohydrate, 1.8 wt. % p-tetrachlorobenzoquinone, 48.3 wt. % ethanol, 8.4 wt. % aniline and 41.5 wt. % ortho-dichlorobenzene. Yield of phenyl urethane: 71.8 mol %.

EXAMPLES 12 TO 17

These Examples demonstrate the catalytic activity of various noble metals which may be used as catalyst component (i). The procedure was the same as that described in Example 1, except that 483 g of a reaction mixture having the following composition were used: 104 ppm of catalyst component (i), 207 ppm of copper (II) acetate monohydrate, 1.8 wt. % p-tetrachlorobenzoquinone, 89.8 wt. % ethanol and 8.4 wt. % aniline. The results obtained are set out in Table 2. Example 12 is a Comparison Example in which no catalyst component (i) was used.

TABLE 2	Yield of phenyl urethane in Example No.	
Catalyst component (i) urethane in mole %		
12 --	1.0	13
13 RuCl.sub.3	55.6	14
14 RhCl.sub.3	38.9	15
15 PdCl.sub.2	57.2	16
16 IrCl.sub.3	35.5	17
17 PtCl.sub.2	4.4	

EXAMPLE 18

This Example demonstrates that catalyst components (i) and (ii) catalyze the urethane-forming reaction even in the absence of catalyst components (iii) and (iv). The procedure was the same as that described in Example 1, except that 482 g of a reaction mixture of the following composition were used: 44 ppm of palladium chloride, 1.8 wt. % p-tetrachlorobenzoquinone, 89.8 wt. % ethanol and 8.4 wt. % aniline. Yield of phenyl urethane: 54.6 mol %.

EXAMPLES 19 TO 23

The procedure was the same as that described in Example 1, except that a 0.7 liter fine-steel autoclave filled with 223 g of reaction mixture of the following composition were used: 22 ppm of palladium chloride, 1.8 wt. % p-tetrachlorobenzoquinone, 90 ppm of catalyst component (iii), 89.8 wt. % ethanol and 8.4 wt. % aniline. The results are shown in Table 3.

TABLE 3	Yield of poly-	Example No.	Catalyst component (iii) urethane in mol %
		19	
Cr(NO ₃) ₃ ·9H ₂ O	59.4	20	Mn(OAc) ₂ ·2H ₂ O
	60.2	21	Co(OAc) ₂ ·2H ₂ O
	65.3	22	Cu(OAc) ₂ ·2H ₂ O
	62.1	23	Mg(NO ₃) ₂ ·6H ₂ O
	60.7		

EXAMPLE 24

This Example demonstrates the catalytic activity of a recycled catalyst. The solid precipitated was filtered off from the product mixture of Example 3, and dried at 50.degree. C. 111 g of a mixture of the following composition were then reacted under the same conditions as described in Example 3 in a 0.3 liter fine-steel autoclave using 1.8 wt. % recovered catalyst mixture, 8.4 wt. % aniline and 89.8 wt. % ethanol. Yield of phenyl urethane: 62.4 mol %.

EXAMPLES 25 TO 29

111.4 g of a mixture of the following composition were introduced into a 0.3 liter fine-steel autoclave: 90 ppm of palladium acetate, 450 ppm of copper acetate monohydrate, 1.8 wt. % tetrachloro-p-benzoquinone, 8.4 wt. % aniline and 89.8 wt. % hydroxy component (see Table 4). 100 bars of carbon monoxide and 25 bars of air were introduced at room temperature. Accordingly, approximately 0.7 oxidation equivalents based on aniline were introduced in the form of atmospheric oxygen. The contents of the autoclave were left to react for 1 hour at 180.degree. C. After cooling, the urethane yields given in Table 4 were obtained according to analysis by gas chromatography.

TABLE 4	Yield of N--phenyl Hydroxy component urethane in mol %
	ethanol 58 1-propanol 64 2-propanol 62 cyclohexanol 34 benzyl alcohol 20

EXAMPLE 30

129.4 g of a mixture of the following composition were introduced into a 0.3 liter fine-steel autoclave: 31 ppm of palladium acetate, 232 ppm of copper acetate monohydrate, 1.5 wt. % tetrachloro-p-benzoquinone, 5.4 wt. % pyridine, 8.5 wt. % (0.1 mol) p-benzoquinone, 7.3 wt. % (0.1 mol) aniline and 77.3 wt. % ethanol. 120 bars of CO were introduced at room temperature. After a reaction time of 2 hours at 180.degree. C., the yield of phenyl urethane amounted to 34

mol % according to analysis by gas chromatography.

EXAMPLE 31

The procedure was the same as that described in Example 30 with the exception that 127.8 g of a starting mixture of the following composition were used: 31 ppm of palladium acetate, 1.6 wt. % tetrachloro-p-benzoquinone, 5.5 wt. % (0.05 mol) copper (II) chloride, 3.4 wt. % (0.05 mol) copper (II) oxide, 3.9 wt. % pyridine, 7.4 wt. % (0.1 mol) aniline and 78.2 wt. % ethanol. Yield of phenyl urethane: 40 mol %.

EXAMPLE 32

216.7 g of a mixture of the following composition were introduced into a 0.7 liter fine-steel autoclave: 50 ppm of palladium acetate, 250 ppm of copper acetate monohydrate, 2.2 wt. % 2,3-dichloronaphthoquinone, 5.5 wt. % tert.-butyl amine and 92.3 wt. % ethanol. 100 bars of CO and 25 bars of air were introduced at room temperature. Accordingly, approximately 1.2 oxidation equivalents based on tert.-butyl amine were introduced in the form of atmospheric oxygen. The contents of the autoclave were left to react with stirring for 1 hour at 180.degree. C. After cooling, analysis by gas chromatography showed a yield of N-tert.-butyl-O-ethyl urethane of 32 mol %.

* * * * *

Appendix 8: Aspen Simulation Report

ASPEN PLUS PLAT: WIN32 VER: 23.0 04/07/2010 PAGE
1

RUN CONTROL SECTION

RUN CONTROL INFORMATION

THIS COPY OF ASPEN PLUS LICENSED TO UNIV OF PENNSYLVANIA

TYPE OF RUN: NEW

INPUT FILE NAME: _4017bcc.inm

OUTPUT PROBLEM DATA FILE NAME: _4017bcc
LOCATED IN:

PDF SIZE USED FOR INPUT TRANSLATION:
 NUMBER OF FILE RECORDS (PSIZE) = 0
 NUMBER OF IN-CORE RECORDS = 256
PSIZE NEEDED FOR SIMULATION = 256

CALLING PROGRAM NAME: apmain
LOCATED IN: C:\PROGRA~1\ASPENT~1\ASPENP~2.1\Engine\xeq

SIMULATION REQUESTED FOR ENTIRE FLOWSHEET

DESCRIPTION

GENERAL SIMULATION WITH ENGLISH UNITS : F, PSI, LB/HR, LBMOL/HR,
BTU/HR, CUFT/HR. PROPERTY METHOD: NONE FLOW BASIS FOR INPUT: MOLE
STREAM REPORT COMPOSITION: MOLE FLOW

ASPEN PLUS PLAT: WIN32 VER: 23.0
2

04/07/2010 PAGE

FLWSHEET SECTION

FLWSHEET CONNECTIVITY BY STREAMS

STREAM	SOURCE	DEST	STREAM	SOURCE	DEST
PSEUDO	----	R-100	SOLVENT	----	R-100
CO	----	R-100	O2	----	R-100
TDA	----	R-100	O2MAKEUP	----	M-102
S-100	R-100	R-101	S-124	R-103	M-103
S-125	R-103	M-101	S-123	R-102	R-103
S-102	C-100	F-100	S-101	R-101	C-100
S-104	R-101	V-100	S-103	F-100	SP-100
S-128	F-100	M-101	S-109	D-100	P-101
S-106	D-100	P-100	S-117	D-101	P-104
S-112	D-101	D-102	S-115	D-102	P-103
S-113	D-102	P-102	S-107	P-100	SP-101
S-118	P-104	SP-102	S-111	H-100	D-101
S-108	SP-101	C-101	S-116	SP-101	M-100
TDI	C-102	----	S-129	M-101	H-102
PSEUDLIQ	H-102	----	S-105	V-100	D-100
S-110	P-101	H-100	S-114	P-102	C-102
WASTEWTR	P-103	----	S-121	M-100	H-101
S-122	H-101	R-102	SLUDGE	C-101	----
S-120	SP-100	M-102	S-127	SP-100	M-103
S-119	SP-102	M-100	S-126	SP-102	M-101
S-130	M-103	H-104	PSEUDVAP	H-104	----
S-132	H-103	R-102	S-131	M-102	H-103

FLWSHEET CONNECTIVITY BY BLOCKS

BLOCK	INLETS	OUTLETS
R-100	TDA O2 CO SOLVENT PSEUDO	S-100
R-103	S-123	S-124 S-125
R-102	S-122 S-132	S-123
C-100	S-101	S-102
R-101	S-100	S-101 S-104
F-100	S-102	S-103 S-128
D-100	S-105	S-109 S-106
D-101	S-111	S-117 S-112
D-102	S-112	S-115 S-113
P-100	S-106	S-107
P-104	S-117	S-118
H-100	S-110	S-111
SP-101	S-107	S-108 S-116
C-102	S-114	TDI
M-101	S-125 S-126 S-128	S-129
H-102	S-129	PSEUDLIQ
V-100	S-104	S-105
P-101	S-109	S-110

Phosgene-Free Route to Toluene Diisocyanate

Bou-Saba, Dizon, Kasih, Stewart

P-102	S-113
P-103	S-115
M-100	S-116 S-119
H-101	S-121
C-101	S-108
SP-100	S-103
SP-102	S-118

S-114
WASTEWTR
S-121
S-122
SLUDGE
S-120 S-127
S-119 S-126

ASPEN PLUS PLAT: WIN32 VER: 23.0
3

04/07/2010 PAGE

FLWSHEET SECTION

FLWSHEET CONNECTIVITY BY BLOCKS (CONTINUED)

M-103	S-127 S-124	S-130
H-104	S-130	PSEUDVAP
H-103	S-131	S-132
M-102	O2MAKEUP S-120	S-131

COMPUTATIONAL SEQUENCE

SEQUENCE USED WAS:

R-100 R-101 C-100 F-100 SP-100 M-102 H-103 V-100 D-100 P-101 H-100
D-101 P-104 SP-102 D-102 P-103 P-102 C-102 P-100 SP-101 C-101 M-100
H-101 R-102 R-103 M-103 H-104 M-101 H-102

OVERALL FLOW SHEET BALANCE

DIFF.	*** MASS AND ENERGY BALANCE ***		*** GENERATION	RELATIVE
	IN	OUT		
CONVENTIONAL COMPONENTS (LBMOL/HR)				
TDA	236.476	8.02549	-228.451	-
0.252396E-14				
O2	266.020	37.5695	-228.451	
0.106840E-15				
CO	4351.80	3894.90	-456.901	
0.835970E-15				
TDI	59.0700	287.044	227.974	-
0.117828E-13				
WATER	92.2390	549.140	456.901	-
0.228765E-13				
TDCARB	22.8930	23.3698	0.476769	
0.264209E-13				
SOLVENT	11153.8	11152.9	-0.953539	
0.140679E-14				
TOTAL BALANCE				
MOLE (LBMOL/HR)	16182.3	15952.9	-229.404	
0.00000				
MASS (LB/HR)	0.129565E+07	0.129565E+07		
0.539106E-15				
ENTHALPY (BTU/HR)	-0.461792E+10	-0.466978E+10		
0.111067E-01				

ASPEN PLUS PLAT: WIN32 VER: 23.0
4

04/07/2010 PAGE

PHYSICAL PROPERTIES SECTION

COMPONENTS

ID	TYPE	FORMULA	NAME OR ALIAS	REPORT
TDA	C	C7H10N2	C7H10N2	TDA
O2	C	O2	O2	O2
CO	C	CO	CO	CO
TDI	C	C9H6N2O2	C9H6N2O2	TDI
WATER	C	H2O	H2O	WATER
TDCARB	C	C13H12F6N2O4	MISSING	TDCARB
SOLVENT	C	C2H3F3O	MISSING	

SOLVENT

LISTID	SUPERCRITICAL COMPONENT LIST
HC-1	O2 CO

ASPEN PLUS PLAT: WIN32 VER: 23.0
5

04/07/2010 PAGE

PROPERTY CONSTANT ESTIMATION SECTION

PURE COMPONENT PARAMETERS

COMPONENT ID: TDCARB FORMULA: C13H12F6N2O4

METHOD OF PROPERTY NAME ESTIMATION	PARAMETER NAME	ESTIMATED VALUE	UNITS
-----	-----	-----	-----
PARACHOR PARACHOR	PARC	650.00	

ASPEN PLUS PLAT: WIN32 VER: 23.0
6

04/07/2010 PAGE

PROPERTY CONSTANT ESTIMATION SECTION

PURE COMPONENT PARAMETERS (CONTINUED)

```
-----  
-----  
COMPONENT ID: SOLVENT FORMULA: C2H3F3O  
-----  
-----  
METHOD OF PROPERTY NAME ESTIMATION  
-----  
PARAMETER ESTIMATED  
NAME VALUE UNITS  
-----  
PARACHOR PARC 157.10  
PARACHOR
```

ASPEN PLUS PLAT: WIN32 VER: 23.0 04/07/2010 PAGE
7

U-O-S BLOCK SECTION

BLOCK: C-100 MODEL: HEATER

INLET STREAM: S-101
OUTLET STREAM: S-102
PROPERTY OPTION SET: NRTL-RK RENON (NRTL) / REDLICH-KWONG

*** MASS AND ENERGY BALANCE ***

	IN	OUT	RELATIVE
DIFF.			
TOTAL BALANCE			
MOLE (LBMOL/HR)	5622.44	5622.44	0.00000
MASS (LB/HR)	292971.	292971.	0.00000
ENTHALPY (BTU/HR)	-0.889850E+09	-0.939393E+09	0.527395E-

01

*** INPUT DATA ***

TWO PHASE TP FLASH		
SPECIFIED TEMPERATURE	F	100.000
PRESSURE DROP	PSI	5.00000
MAXIMUM NO. ITERATIONS		30
CONVERGENCE TOLERANCE		0.000100000

*** RESULTS ***

OUTLET TEMPERATURE	F	100.00
OUTLET PRESSURE	PSIA	647.67
HEAT DUTY	BTU/HR	-0.49543E+08
OUTLET VAPOR FRACTION		0.52478
PRESSURE-DROP CORRELATION PARAMETER		2556.5

V-L PHASE EQUILIBRIUM :

COMP	F (I)	X (I)	Y (I)	K (I)
TDA	0.17052E-05	0.35883E-05	0.14437E-12	
0.40234E-07				
O2	0.55224E-02	0.37623E-02	0.71162E-02	
1.8915				
CO	0.65559	0.29194	0.98490	
3.3737				
TDI	0.34859E-04	0.73354E-04	0.20932E-09	
0.28536E-05				
WATER	0.41174E-02	0.86594E-02	0.43053E-05	
0.49719E-03				
TDCARB	0.36533E-08	0.76875E-08	0.70156E-18	
0.91260E-10				

SOLVENT	0.33473	0.69556	0.79807E-02
0.11474E-01			

ASPEN PLUS PLAT: WIN32 VER: 23.0 04/07/2010 PAGE 8

U-O-S BLOCK SECTION

BLOCK: C-101 MODEL: HEATER

 INLET STREAM: S-108
 OUTLET STREAM: SLUDGE
 PROPERTY OPTION SET: NRTL-RK RENON (NRTL) / REDLICH-KWONG

*** MASS AND ENERGY BALANCE ***
 IN OUT RELATIVE

DIFF.		IN	OUT	RELATIVE
	TOTAL BALANCE			
	MOLE (LBMOL/HR)	0.902484	0.902484	0.00000
	MASS (LB/HR)	230.488	230.488	0.00000
	ENTHALPY (BTU/HR)	-358388.	-386244.	0.721215E-

01

*** INPUT DATA ***

TWO PHASE TP FLASH
 SPECIFIED TEMPERATURE F 140.000
 PRESSURE DROP PSI 5.00000
 MAXIMUM NO. ITERATIONS 30
 CONVERGENCE TOLERANCE
 0.000100000

*** RESULTS ***

OUTLET TEMPERATURE F 140.00
 OUTLET PRESSURE PSIA 648.00
 HEAT DUTY BTU/HR -27856.
 OUTLET VAPOR FRACTION 0.0000
 PRESSURE-DROP CORRELATION PARAMETER 0.58467E+11

V-L PHASE EQUILIBRIUM :

COMP	F(I)	X(I)	Y(I)	K(I)
TDA	0.47145	0.47145	0.99834	
0.19236E-05				
TDI	0.44676E-04	0.44676E-04	0.74118E-03	
0.15070E-04				
TDCARB	0.52850	0.52850	0.91469E-03	
0.15722E-08				

BLOCK: C-102 MODEL: HEATER

 INLET STREAM: S-114
 OUTLET STREAM: TDI
 PROPERTY OPTION SET: NRTL-RK RENON (NRTL) / REDLICH-KWONG

ASPEN PLUS PLAT: WIN32 VER: 23.0 04/07/2010 PAGE
9

U-O-S BLOCK SECTION

BLOCK: C-102 MODEL: HEATER (CONTINUED)

```

*** MASS AND ENERGY BALANCE ***
                                IN          OUT          RELATIVE
DIFF.
TOTAL BALANCE
MOLE (LBMOL/HR)                227.981        227.981        0.00000
MASS (LB/HR )                   39662.8        39662.8        0.00000
ENTHALPY (BTU/HR )              -0.842921E+07  -0.116233E+08  0.274799
    
```

```

*** INPUT DATA ***
TWO PHASE TP FLASH
SPECIFIED TEMPERATURE          F          140.000
PRESSURE DROP                   PSI         5.00000
MAXIMUM NO. ITERATIONS
CONVERGENCE TOLERANCE
0.000100000
    
```

```

*** RESULTS ***
OUTLET TEMPERATURE             F          140.00
OUTLET PRESSURE                 PSIA       2.0077
HEAT DUTY                       BTU/HR     -0.31941E+07
OUTLET VAPOR FRACTION
PRESSURE-DROP CORRELATION PARAMETER 0.15340E+07
    
```

V-L PHASE EQUILIBRIUM :

COMP	F (I)	X (I)	Y (I)	K (I)
TDA 0.40867E-03	0.36978E-04	0.36978E-04	0.33406E-05	
TDI 0.28459E-02	0.99879	0.99879	0.62835	
WATER 1.4360	0.11707E-02	0.11707E-02	0.37164	

BLOCK: D-100 MODEL: RADFRAC

```

-----
INLETS   - S-105   STAGE  11
OUTLETS  - S-109   STAGE   1
          S-106   STAGE  20
PROPERTY OPTION SET:  NRTL-RK  RENON (NRTL) / REDLICH-KWONG
    
```

ASPEN PLUS PLAT: WIN32 VER: 23.0 04/07/2010 PAGE 10

U-O-S BLOCK SECTION

BLOCK: D-100 MODEL: RADFRAC (CONTINUED)

		*** MASS AND ENERGY BALANCE ***		
DIFF.		IN	OUT	RELATIVE
TOTAL BALANCE				
	MOLE (LBMOL/HR)	10279.4	10279.4	0.00000
	MASS (LB/HR)	0.100149E+07	0.100149E+07	0.348725E-
15				
	ENTHALPY (BTU/HR)	-0.373429E+10	-0.383866E+10	0.271883E-
01				

 **** INPUT DATA ****

**** INPUT PARAMETERS ****

NUMBER OF STAGES	20
ALGORITHM OPTION	STANDARD
ABSORBER OPTION	NO
INITIALIZATION OPTION	STANDARD
HYDRAULIC PARAMETER CALCULATIONS	NO
INSIDE LOOP CONVERGENCE METHOD	BROYDEN
DESIGN SPECIFICATION METHOD	NESTED
MAXIMUM NO. OF OUTSIDE LOOP ITERATIONS	25
MAXIMUM NO. OF INSIDE LOOP ITERATIONS	10
MAXIMUM NUMBER OF FLASH ITERATIONS	50
FLASH TOLERANCE	0.000100000
OUTSIDE LOOP CONVERGENCE TOLERANCE	0.000100000

**** COL-SPECS ****

MOLAR VAPOR DIST / TOTAL DIST	0.0
MOLAR REFLUX RATIO	2.40000
MOLAR DISTILLATE RATE	LBMOL/HR 10,189.1

**** PROFILES ****

P-SPEC	STAGE 1	PRES, PSIA	2.00000
--------	---------	------------	---------

ASPEN PLUS PLAT: WIN32 VER: 23.0
11

04/07/2010 PAGE

U-O-S BLOCK SECTION

BLOCK: D-100 MODEL: RADFRAC (CONTINUED)

**** RESULTS ****

*** COMPONENT SPLIT FRACTIONS ***

COMPONENT:	OUTLET STREAMS	
	S-109	S-106
TDA	.19811E-03	.99980
O2	1.0000	.11312E-47
CO	1.0000	.46459E-50
TDI	.99998	.17685E-04
WATER	1.0000	.27621E-25
TDCARB	.20432E-33	1.0000
SOLVENT	1.0000	.84761E-23

*** SUMMARY OF KEY RESULTS ***

TOP STAGE TEMPERATURE	F	34.9811
BOTTOM STAGE TEMPERATURE	F	517.842
TOP STAGE LIQUID FLOW	LBMOL/HR	24,453.9
BOTTOM STAGE LIQUID FLOW	LBMOL/HR	90.2484
TOP STAGE VAPOR FLOW	LBMOL/HR	0.0
BOILUP VAPOR FLOW	LBMOL/HR	21,097.0
MOLAR REFLUX RATIO		2.40000
MOLAR BOILUP RATIO		233.765
CONDENSER DUTY (W/O SUBCOOL)	BTU/HR	-0.729901+09
REBOILER DUTY	BTU/HR	0.625534+09

**** MAXIMUM FINAL RELATIVE ERRORS ****

DEW POINT	0.21152E-03	STAGE= 8
BUBBLE POINT	0.59523E-04	STAGE= 8
COMPONENT MASS BALANCE	0.28139E-05	STAGE= 10 COMP=WATER
ENERGY BALANCE	0.54301E-04	STAGE= 7

ASPEN PLUS PLAT: WIN32 VER: 23.0
12

04/07/2010 PAGE

U-O-S BLOCK SECTION

BLOCK: D-100 MODEL: RADFRAC (CONTINUED)

**** PROFILES ****

NOTE REPORTED VALUES FOR STAGE LIQUID AND VAPOR RATES ARE THE FLOWS FROM THE STAGE EXCLUDING ANY SIDE PRODUCT. FOR THE FIRST STAGE, THE REPORTED VAPOR FLOW IS THE VAPOR DISTILLATE FLOW. FOR THE LAST STAGE, THE REPORTED LIQUID FLOW IS THE LIQUID BOTTOMS FLOW.

STAGE	TEMPERATURE F	PRESSURE PSIA	ENTHALPY BTU/LBMOL		HEAT DUTY BTU/HR
			LIQUID	VAPOR	
1	34.981	2.0000	-0.37322E+06	-0.18804E+06	-.72990+09
2	203.05	2.2000	-61491.	-0.35215E+06	
3	335.21	2.3500	-39412.	-0.16057E+06	
9	376.12	3.2500	-18220.	-0.12681E+06	
10	391.96	3.4000	-5602.5	-0.12272E+06	
11	419.97	3.5500	3498.2	-50888.	
12	443.06	3.7000	10356.	33082.	
19	465.75	4.7500	9648.5	43760.	
20	517.84	4.9000	-0.39758E+06	41041.	.62553+09

STAGE	FLOW RATE LBMOL/HR		FEED RATE LBMOL/HR			PRODUCT RATE LBMOL/HR
	LIQUID	VAPOR	LIQUID	VAPOR	MIXED	LIQUID
VAPOR						
1	0.2445E+05	0.000				.10189+05
2	0.1450E+05	0.3464E+05				
3	0.1875E+05	0.2469E+05				
9	0.1744E+05	0.2836E+05				
10	0.1796E+05	0.2763E+05		5554.1851		
11	0.2246E+05	0.2259E+05	4725.1792			
12	0.2327E+05	0.2237E+05				
19	0.2119E+05	0.2345E+05				
20	90.25	0.2110E+05				90.2484

**** MASS FLOW PROFILES ****

STAGE	FLOW RATE LB/HR		FEED RATE LB/HR			PRODUCT RATE LB/HR
	LIQUID	VAPOR	LIQUID	VAPOR	MIXED	LIQUID
VAPOR						
1	0.2348E+07	0.000				.97844+06
2	0.2465E+07	0.3327E+07				
3	0.3258E+07	0.3443E+07				
9	0.2675E+07	0.3967E+07				

10	0.2522E+07	0.3654E+07		.52964+06
11	0.2962E+07	0.2971E+07	.47185+06	
12	0.2953E+07	0.2938E+07		
19	0.2640E+07	0.2865E+07		
20	0.2305E+05	0.2617E+07		.23049+05

ASPEN PLUS PLAT: WIN32 VER: 23.0
13

04/07/2010 PAGE

U-O-S BLOCK SECTION

BLOCK: D-100 MODEL: RADFRAC (CONTINUED)

STAGE	TDA	O2	CO	TDI	WATER
1	0.82744E-06	0.39851E-03	0.27281E-01	0.22375E-01	
0.44843E-01					
2	0.20251E-03	0.11130E-06	0.40953E-05	0.95220	
0.81070E-02					
3	0.70825E-03	0.16526E-07	0.64174E-06	0.99517	
0.51475E-03					
9	0.39399	0.11310E-06	0.50720E-05	0.60238	
0.22183E-03					
10	0.64314	0.22856E-06	0.11308E-04	0.35335	
0.16185E-03					
11	0.81898	0.84008E-08	0.30590E-06	0.17713	
0.10941E-03					
12	0.91773	0.16742E-11	0.46061E-10	0.80203E-01	
0.54369E-06					
19	0.99012	0.13218E-45	0.53595E-46	0.19654E-03	
0.27673E-22					
20	0.47145	0.50897E-49	0.14310E-49	0.44676E-04	
0.13984E-24					

STAGE	TDCARB	SOLVENT
1	0.95647E-36	0.90510
2	0.46356E-30	0.39487E-01
3	0.97937E-27	0.36027E-02
9	0.87891E-08	0.33990E-02
10	0.54666E-05	0.33317E-02
11	0.21310E-02	0.16523E-02
12	0.20573E-02	0.14382E-04
19	0.96808E-02	0.91988E-19
20	0.52850	0.86615E-21

STAGE	TDA	O2	CO	TDI	WATER
1	0.35569E-12	0.57760E-02	0.57760	0.24389E-06	
0.12752E-02					
2	0.82744E-06	0.39851E-03	0.27281E-01	0.22375E-01	
0.44843E-01					
3	0.11928E-03	0.16452E-03	0.11260E-01	0.56849	
0.23267E-01					
9	0.11636	0.14319E-03	0.98018E-02	0.53013	
0.16291E-01					
10	0.24870	0.14703E-03	0.10064E-01	0.38849	
0.16677E-01					
11	0.51121	0.96825E-05	0.45506E-03	0.29096	
0.16872E-01					

12	0.82038	0.84347E-08	0.30713E-06	0.17784
0.10985E-03				
19	0.99949	0.10011E-40	0.74306E-41	0.46593E-03
0.57158E-20				
20	0.99234	0.13275E-45	0.53824E-46	0.19719E-03
0.27791E-22				

```
**** MOLE-Y-PROFILE ****
STAGE      TDCARB      SOLVENT
  1      0.63606E-46  0.41535
  2      0.95647E-36  0.90510
  3      0.27227E-30  0.39670
  9      0.60109E-11  0.32727
 10      0.55479E-08  0.33593
 11      0.43452E-05  0.18050
 12      0.71683E-05  0.16590E-02
 19      0.45189E-04  0.91468E-17
 20      0.74614E-02  0.92377E-19
```

ASPEN PLUS PLAT: WIN32 VER: 23.0
14

04/07/2010 PAGE

U-O-S BLOCK SECTION

BLOCK: D-100 MODEL: RADFRAC (CONTINUED)

		**** K-VALUES ****				
STAGE	TDA	O2	CO	TDI	WATER	
1	0.42987E-06	14.494	21.172	0.10900E-04		
0.28437E-01						
2	0.40850E-02	3581.0	6662.2	0.23494E-01	5.5314	
3	0.16841	9955.7	17548.	0.57124	45.201	
9	0.29534	1266.3	1932.9	0.88004	73.436	
10	0.38669	643.33	890.03	1.0994	103.04	
11	0.62420	1152.5	1487.5	1.6426	154.20	
12	0.89393	5037.3	6666.8	2.2174	202.05	
19	1.0095	75734.	0.13864E+06	2.3706	206.54	
20	2.1049	2608.1	3761.4	4.4139	198.73	

		**** K-VALUES ****	
STAGE	TDCARB	SOLVENT	
1	0.66501E-10	0.45890	
2	0.20626E-05	22.923	
3	0.27798E-03	110.11	
9	0.68366E-03	96.289	
10	0.10149E-02	100.83	
11	0.20391E-02	109.24	
12	0.34844E-02	115.35	
19	0.46679E-02	99.435	
20	0.14118E-01	106.65	

		**** MASS-X-PROFILE ****				
STAGE	TDA	O2	CO	TDI	WATER	
1	0.10527E-05	0.13279E-03	0.79576E-02	0.40579E-01		
0.84127E-02						
2	0.14557E-03	0.20955E-07	0.67495E-06	0.97575		
0.85934E-03						
3	0.49792E-03	0.30431E-08	0.10344E-06	0.99737		
0.53365E-04						
9	0.31380	0.23594E-07	0.92621E-06	0.68395		
0.26054E-04						
10	0.55943	0.52073E-07	0.22552E-05	0.43816		
0.20760E-04						
11	0.75875	0.20385E-08	0.64976E-07	0.23394		
0.14947E-04						
12	0.88381	0.42229E-12	0.10170E-10	0.11011		
0.77210E-07						
19	0.97065	0.33940E-46	0.12046E-46	0.27467E-03		
0.40005E-23						
20	0.22552	0.63771E-50	0.15694E-50	0.30466E-04		
0.98643E-26						

**** MASS-X-PROFILE ****

STAGE	TDCARB	SOLVENT
1	0.37275E-35	0.94292
2	0.10208E-29	0.23243E-01
3	0.21092E-26	0.20741E-02
9	0.21444E-07	0.22168E-02
10	0.14566E-04	0.23731E-02
11	0.60476E-02	0.12535E-02
12	0.60691E-02	0.11342E-04
19	0.29072E-01	0.73844E-19
20	0.77445	0.33928E-21

U-O-S BLOCK SECTION

BLOCK: D-100 MODEL: RADFRAC (CONTINUED)

		**** MASS-Y-PROFILE ****			
STAGE	TDA	O2	CO	TDI	WATER
1	0.75001E-12	0.31901E-02	0.27924	0.73310E-06	
0.39651E-03					
2	0.10527E-05	0.13279E-03	0.79576E-02	0.40579E-01	
0.84127E-02					
3	0.10450E-03	0.37751E-04	0.22618E-02	0.71000	
0.30058E-02					
9	0.10165	0.32762E-04	0.19631E-02	0.66016	
0.20985E-02					
10	0.22977	0.35580E-04	0.21318E-02	0.51165	
0.22720E-02					
11	0.47493	0.23561E-05	0.96929E-04	0.38534	
0.23113E-02					
12	0.76293	0.20545E-08	0.65486E-07	0.23577	
0.15064E-04					
19	0.99920	0.26212E-41	0.17031E-41	0.66401E-03	
0.84260E-21					
20	0.97722	0.34239E-46	0.12152E-46	0.27682E-03	
0.40356E-23					

		**** MASS-Y-PROFILE ****	
STAGE	TDCARB	SOLVENT	
1	0.41085E-45	0.71717	
2	0.37275E-35	0.94292	
3	0.73068E-30	0.28459	
9	0.16084E-10	0.23410	
10	0.15701E-07	0.25414	
11	0.12366E-04	0.13731	
12	0.20421E-04	0.12634E-02	
19	0.13839E-03	0.74878E-17	
20	0.22508E-01	0.74491E-19	

 ***** HYDRAULIC PARAMETERS *****

*** DEFINITIONS ***

MARANGONI INDEX = SIGMA - SIGMATO
 FLOW PARAM = (ML/MV) * SQRT (RHOV/RHOL)
 QR = QV * SQRT (RHOV / (RHOL - RHOV))
 F FACTOR = QV * SQRT (RHOV)

WHERE:

SIGMA IS THE SURFACE TENSION OF LIQUID FROM THE STAGE

SIGMATO IS THE SURFACE TENSION OF LIQUID TO THE STAGE

ML IS THE MASS FLOW OF LIQUID FROM THE STAGE

MV IS THE MASS FLOW OF VAPOR TO THE STAGE

RHOL IS THE MASS DENSITY OF LIQUID FROM THE STAGE

RHOV IS THE MASS DENSITY OF VAPOR TO THE STAGE

QV IS THE VOLUMETRIC FLOW RATE OF VAPOR TO THE STAGE

ASPEN PLUS PLAT: WIN32 VER: 23.0
16

04/07/2010 PAGE

U-O-S BLOCK SECTION

BLOCK: D-100 MODEL: RADFRAC (CONTINUED)

TEMPERATURE

F

STAGE	LIQUID FROM	VAPOR TO
1	34.981	203.05
2	203.05	335.21
3	335.21	345.58
9	376.12	391.96
10	391.96	384.96
11	419.97	443.06
12	443.06	449.36
19	465.75	517.84
20	517.84	517.84

STAGE	MASS FLOW LB/HR		VOLUME FLOW CUFT/HR		MOLECULAR WEIGHT	
	LIQUID FROM	VAPOR TO	LIQUID FROM	VAPOR TO	LIQUID FROM	VAPOR
1	0.33267E+07	0.33267E+07	33267.	0.11175E+09	96.028	96.028
2	0.24647E+07	0.34431E+07	34288.	0.89262E+08	169.96	139.45
3	0.32585E+07	0.42369E+07	49126.	0.99563E+08	173.77	146.40
9	0.26751E+07	0.36536E+07	42313.	0.73878E+08	153.39	132.24
10	0.25224E+07	0.35009E+07	40916.	0.74643E+08	140.45	124.37
11	0.29615E+07	0.29385E+07	49334.	0.58129E+08	131.87	131.37
12	0.29526E+07	0.29295E+07	50190.	0.58302E+08	126.86	126.36
19	0.26404E+07	0.26173E+07	45428.	0.44806E+08	124.62	124.06
20	23049.	0.26173E+07	280.41	0.44806E+08	255.39	124.06

STAGE	DENSITY LB/CUFT		VISCOSITY CP		SURFACE TENSION DYNE/CM	
	LIQUID FROM	VAPOR TO	LIQUID FROM	VAPOR TO	LIQUID FROM	
1	100.00	0.29770E-01	0.50678	0.14129E-01	33.667	
2	71.881	0.38573E-01	0.88676	0.10909E-01	39.173	
3	66.330	0.42555E-01	0.49269	0.10435E-01	29.385	
9	63.221	0.49454E-01	0.47622	0.11349E-01	29.161	
10	61.649	0.46902E-01	0.48495	0.11335E-01	29.871	
11	60.029	0.50551E-01	0.46044	0.98089E-02	29.321	
12	58.828	0.50248E-01	0.43608	0.99125E-02	28.563	
19	58.122	0.58415E-01	0.41511	0.10703E-01	27.690	
20	82.197	0.58415E-01	0.54784	0.10703E-01	25.155	

STAGE	MARANGONI INDEX DYNE/CM	FLOW PARAM	QR CUFT/HR	REDUCED F-FACTOR (LB-CUFT)**.5/HR
1		0.17254E-01	0.19284E+07	0.19281E+08

2	5.5061	0.16582E-01	0.20683E+07	0.17531E+08
3	-9.7881	0.19480E-01	0.25227E+07	0.20539E+08
9	0.66879	0.20478E-01	0.20671E+07	0.16429E+08
10	0.70969	0.19873E-01	0.20596E+07	0.16165E+08
11	1.4709	0.29247E-01	0.16876E+07	0.13069E+08
12	-.75841	0.29456E-01	0.17046E+07	0.13069E+08
19	-.15946	0.31981E-01	0.14212E+07	0.10829E+08

U-O-S BLOCK SECTION

BLOCK: D-100 MODEL: RADFRAC (CONTINUED)

STAGE	MARANGONI INDEX DYNE/CM	FLOW PARAM	QR CUFT/HR	REDUCED F-FACTOR (LB-CUFT)**.5/HR
20	-2.5344	0.23476E-03	0.11949E+07	0.10829E+08

***** PACKING SIZING CALCULATIONS *****

*** SECTION 1 ***

STARTING STAGE NUMBER	2
ENDING STAGE NUMBER	19
CAPACITY CALCULATION METHOD	KOCH
PRESSURE DROP CALCULATION METHOD	KOCH
LIQUID HOLDUP CALCULATION METHOD	STICHL
PRESSURE PROFILE UPDATED	NO

DESIGN PARAMETERS

OVERDESIGN FACTOR	1.00000	
SYSTEM FOAMING FACTOR	1.00000	
FRAC. APP. TO MAXIMUM CAPACITY	0.85000	
MAXIMUM CAPACITY FACTOR	FT/SEC	MISSING
DESIGN CAPACITY FACTOR	FT/SEC	MISSING
PRESSURE DROP FOR THE SECTION	PSI	MISSING
PRESSURE DROP PER UNIT HEIGHT	IN-WATER/FT	MISSING

PACKING SPECIFICATIONS

PACKING TYPE	FLEXIPAC	
PACKING MATERIAL	METAL	
PACKING SIZE	500Y	
VENDOR	KOCH	
PACKING FACTOR	1/FT	67.6917
PACKING SURFACE AREA	SQFT/CUF	152.402
PACKING VOID FRACTION	0.92000	
FIRST STICHLMAIR CONSTANT	0.77242	
SECOND STICHLMAIR CONSTANT	-0.10883	
THIRD STICHLMAIR CONSTANT	0.11184	
HETP	FT	1.33333

PACKING HEIGHT

FT

24.0000

ASPEN PLUS PLAT: WIN32 VER: 23.0
18

04/07/2010 PAGE

U-O-S BLOCK SECTION

BLOCK: D-100 MODEL: RADFRAC (CONTINUED)

***** SIZING RESULTS *****

COLUMN DIAMETER	FT	63.1678
MAXIMUM FRACTIONAL CAPACITY		0.85000
MAXIMUM CAPACITY FACTOR	FT/SEC	0.22360
PRESSURE DROP FOR THE SECTION	PSI	0.21255
AVERAGE PRESSURE DROP/HEIGHT	IN-WATER/FT	0.24514
MAXIMUM LIQUID HOLDUP/STAGE	CUFT	120.362
MAX LIQ SUPERFICIAL VELOCITY	FT/SEC	0.0044702

**** RATING PROFILES AT MAXIMUM COLUMN DIAMETER ****

STAGE	HEIGHT FROM TOP OF SECTION FT	FRACTIONAL CAPACITY	PRESSURE DROP PSI	PRESSURE DROP/HEIGHT IN-WATER/FT	LIQUID HOLDUP CUFT	HETP FT
2	0.000	0.6882	0.13284E-01	0.27577	93.02	
1.333						
3	1.333	0.8500	0.22235E-01	0.46160	118.3	
1.333						
4	2.667	0.8445	0.21721E-01	0.45092	120.3	
1.333						
5	4.000	0.8261	0.20084E-01	0.41693	120.4	
1.333						
6	5.333	0.8057	0.18442E-01	0.38285	119.8	
1.333						
7	6.667	0.7803	0.16607E-01	0.34477	118.0	
1.333						
8	8.000	0.7444	0.14404E-01	0.29904	113.7	
1.333						
9	9.333	0.7003	0.12160E-01	0.25244	107.0	
1.333						
10	10.67	0.6955	0.11712E-01	0.24315	104.7	
1.333						
11	12.00	0.5977	0.77623E-02	0.16115	118.5	
1.333						
12	13.33	0.6041	0.78112E-02	0.16216	119.9	
1.333						
13	14.67	0.5929	0.74349E-02	0.15435	119.2	
1.333						
14	16.00	0.5840	0.71532E-02	0.14850	119.0	
1.333						
15	17.33	0.5765	0.69199E-02	0.14366	119.0	
1.333						

Phosgene-Free Route to Toluene Diisocyanate

Bou-Saba, Dizon, Kasih, Stewart

16	18.67	0.5696	0.67136E-02	0.13937	119.2
1.333					
17	20.00	0.5632	0.65250E-02	0.13546	119.4
1.333					
18	21.33	0.5567	0.63391E-02	0.13160	119.5
1.333					
19	22.67	0.5092	0.52436E-02	0.10886	112.2
1.333					

LIQUID
SUPERFICIAL

STAGE	VELOCITY FT/SEC
2	0.3039E-02
3	0.4354E-02
4	0.4467E-02
5	0.4470E-02
6	0.4440E-02
7	0.4340E-02
8	0.4107E-02
9	0.3751E-02
10	0.3627E-02
11	0.4373E-02
12	0.4449E-02
13	0.4408E-02
14	0.4397E-02
15	0.4400E-02
16	0.4409E-02
17	0.4419E-02

ASPEN PLUS PLAT: WIN32 VER: 23.0
19

04/07/2010 PAGE

U-O-S BLOCK SECTION

BLOCK: D-100 MODEL: RADFRAC (CONTINUED)

LIQUID
SUPERFICIAL
STAGE VELOCITY
FT/SEC
18 0.4426E-02
19 0.4027E-02

***** TRAY SIZING CALCULATIONS *****

*** SECTION 1 ***

STARTING STAGE NUMBER 2
ENDING STAGE NUMBER 19
FLOODING CALCULATION METHOD B960

DESIGN PARAMETERS

PEAK CAPACITY FACTOR 1.00000
SYSTEM FOAMING FACTOR 1.00000
FLOODING FACTOR 0.80000
MINIMUM COLUMN DIAMETER FT 1.00000
MINIMUM DC AREA/COLUMN AREA 0.100000

TRAY SPECIFICATIONS

TRAY TYPE FLEXI
NUMBER OF PASSES 1
TRAY SPACING FT 2.00000

***** SIZING RESULTS @ STAGE WITH MAXIMUM DIAMETER *****

STAGE WITH MAXIMUM DIAMETER 5
COLUMN DIAMETER FT 9.56522
DC AREA/COLUMN AREA 0.50000
DOWNCOMER VELOCITY FT/SEC 0.38990
WEIR LENGTH FT 9.56522

ASPEN PLUS PLAT: WIN32 VER: 23.0
20

04/07/2010 PAGE

U-O-S BLOCK SECTION

BLOCK: D-100 MODEL: RADFRAC (CONTINUED)

**** SIZING PROFILES ****

STAGE	DIAMETER FT	TOTAL AREA SQFT	ACTIVE AREA SQFT	SIDE DC AREA SQFT
2	7.8870	48.855	-0.13400E-03	24.428
3	9.4405	69.997	-0.19199E-03	34.999
4	9.5615	71.803	-0.19695E-03	35.902
5	9.5652	71.859	-0.19710E-03	35.929
6	9.5332	71.379	-0.19578E-03	35.690
7	9.4254	69.774	-0.19138E-03	34.887
8	9.1686	66.023	-0.18109E-03	33.012
9	8.7615	60.291	-0.16537E-03	30.145
10	8.6156	58.299	-0.15991E-03	29.150
11	9.4605	70.294	-0.19281E-03	35.147
12	9.5422	71.513	-0.19615E-03	35.757
13	9.4982	70.855	-0.19435E-03	35.428
14	9.4867	70.684	-0.19388E-03	35.342
15	9.4899	70.731	-0.19401E-03	35.366
16	9.4991	70.868	-0.19438E-03	35.434
17	9.5105	71.039	-0.19485E-03	35.520
18	9.5181	71.152	-0.19516E-03	35.576
19	9.0782	64.728	-0.17754E-03	32.364

BLOCK: D-101 MODEL: RADFRAC

 INLETS - S-111 STAGE 11
 OUTLETS - S-117 STAGE 1
 S-112 STAGE 20

PROPERTY OPTION SET: NRTL-RK RENON (NRTL) / REDLICH-KWONG

*** MASS AND ENERGY BALANCE ***

DIFF.		IN	OUT	RELATIVE
	TOTAL BALANCE			
	MOLE (LBMOL/HR)	10189.1	10189.1	0.00000
15	MASS (LB/HR)	978444.	978444.	0.356940E-
01	ENTHALPY (BTU/HR)	-0.362940E+10	-0.379828E+10	0.444638E-

ASPEN PLUS PLAT: WIN32 VER: 23.0 04/07/2010 PAGE
21

U-O-S BLOCK SECTION

BLOCK: D-101 MODEL: RADFRAC (CONTINUED)

**** INPUT DATA ****

**** INPUT PARAMETERS ****

NUMBER OF STAGES	20
ALGORITHM OPTION	STANDARD
ABSORBER OPTION	NO
INITIALIZATION OPTION	STANDARD
HYDRAULIC PARAMETER CALCULATIONS	NO
INSIDE LOOP CONVERGENCE METHOD	BROYDEN
DESIGN SPECIFICATION METHOD	NESTED
MAXIMUM NO. OF OUTSIDE LOOP ITERATIONS	200
MAXIMUM NO. OF INSIDE LOOP ITERATIONS	10
MAXIMUM NUMBER OF FLASH ITERATIONS	50
FLASH TOLERANCE	0.000100000
OUTSIDE LOOP CONVERGENCE TOLERANCE	0.000100000

**** COL-SPECS ****

MOLAR VAPOR DIST / TOTAL DIST	0.0
MOLAR REFLUX RATIO	1.05000
MOLAR DISTILLATE RATE	LBMOL/HR
	9,504.23

**** PROFILES ****

P-SPEC	STAGE	1	PRES, PSIA	5.00000
--------	-------	---	------------	---------

**** RESULTS ****

*** COMPONENT SPLIT FRACTIONS ***

	OUTLET STREAMS	
	S-117	S-112
COMPONENT:	-----	
TDA	.64450E-43	1.0000
O2	1.0000	.62951E-27
CO	1.0000	.13582E-29
TDI	.36535E-34	1.0000

ASPEN PLUS PLAT: WIN32 VER: 23.0
22

04/07/2010 PAGE

U-O-S BLOCK SECTION

BLOCK: D-101 MODEL: RADFRAC (CONTINUED)

*** COMPONENT SPLIT FRACTIONS ***

	OUTLET STREAMS	
	S-117	S-112
COMPONENT:		
WATER	.19749E-04	.99998
SOLVENT	1.0000	.10598E-07

*** SUMMARY OF KEY RESULTS ***

TOP STAGE TEMPERATURE	F	34.0916
BOTTOM STAGE TEMPERATURE	F	200.714
TOP STAGE LIQUID FLOW	LBMOL/HR	9,979.44
BOTTOM STAGE LIQUID FLOW	LBMOL/HR	684.886
TOP STAGE VAPOR FLOW	LBMOL/HR	0.0
BOILUP VAPOR FLOW	LBMOL/HR	10,114.0
MOLAR REFLUX RATIO		1.05000
MOLAR BOILUP RATIO		14.7674
CONDENSER DUTY (W/O SUBCOOL)	BTU/HR	-0.351769+09
REBOILER DUTY	BTU/HR	0.182883+09

**** MAXIMUM FINAL RELATIVE ERRORS ****

DEW POINT	0.11939E-03	STAGE= 1
BUBBLE POINT	0.39567E-03	STAGE= 13
COMPONENT MASS BALANCE	0.67691E-06	STAGE= 11 COMP=TDI
ENERGY BALANCE	0.11162E-03	STAGE= 13

ASPEN PLUS PLAT: WIN32 VER: 23.0 04/07/2010 PAGE 23

U-O-S BLOCK SECTION

BLOCK: D-101 MODEL: RADFRAC (CONTINUED)

**** PROFILES ****

NOTE REPORTED VALUES FOR STAGE LIQUID AND VAPOR RATES ARE THE FLOWS FROM THE STAGE EXCLUDING ANY SIDE PRODUCT. FOR THE FIRST STAGE, THE REPORTED VAPOR FLOW IS THE VAPOR DISTILLATE FLOW. FOR THE LAST STAGE, THE REPORTED LIQUID FLOW IS THE LIQUID BOTTOMS FLOW.

STAGE	TEMPERATURE F	PRESSURE PSIA	ENTHALPY BTU/LBMOL		HEAT DUTY BTU/HR
			LIQUID	VAPOR	
1	34.092	5.0000	-0.39271E+06	-0.10538E+06	-.35177+09
2	93.227	5.1000	-0.40079E+06	-0.37465E+06	
3	94.954	5.2500	-0.40073E+06	-0.38002E+06	
4	96.030	5.4000	-0.40067E+06	-0.38000E+06	
5	97.085	5.5500	-0.40059E+06	-0.37997E+06	
9	101.66	6.1500	-0.39526E+06	-0.37891E+06	
10	103.76	6.3000	-0.38563E+06	-0.37697E+06	
11	108.02	6.4500	-0.36353E+06	-0.37777E+06	
12	115.57	6.6000	-0.31741E+06	-0.36355E+06	
19	181.88	7.6500	-0.11932E+06	-0.10313E+06	
20	200.71	7.8000	-96220.	-0.10281E+06	.18288+09

STAGE	FLOW RATE LBMOL/HR		FEED RATE LBMOL/HR			PRODUCT RATE LBMOL/HR
	LIQUID	VAPOR	LIQUID	VAPOR	MIXED	LIQUID
VAPOR						
1	9979.	0.000				9504.2300
2	0.1113E+05	0.1948E+05				
3	0.1114E+05	0.2063E+05				
4	0.1114E+05	0.2065E+05				
5	0.1114E+05	0.2064E+05				
9	0.1105E+05	0.2061E+05				
10	0.1080E+05	0.2056E+05		9080.2743		
11	0.1175E+05	0.1122E+05	1108.8416			
12	0.1137E+05	0.1107E+05				
19	0.1080E+05	0.1020E+05				
20	684.9	0.1011E+05				684.8860

**** MASS FLOW PROFILES ****

STAGE	FLOW RATE LB/HR		FEED RATE LB/HR			PRODUCT RATE LB/HR
	LIQUID	VAPOR	LIQUID	VAPOR	MIXED	LIQUID
VAPOR						

1	0.9770E+06	0.000		.93051+06
2	0.1113E+07	0.1908E+07		
3	0.1115E+07	0.2044E+07		
4	0.1114E+07	0.2045E+07		
5	0.1114E+07	0.2045E+07		
9	0.1089E+07	0.2036E+07		
10	0.1033E+07	0.2019E+07	.86257+06	
11	0.1089E+07	0.1101E+07	.11587+06	

ASPEN PLUS PLAT: WIN32 VER: 23.0 04/07/2010 PAGE 24

U-O-S BLOCK SECTION

BLOCK: D-101 MODEL: RADFRAC (CONTINUED)

**** MASS FLOW PROFILES ****

STAGE	FLOW RATE		FEED RATE			PRODUCT RATE
	LB/HR		LB/HR			LB/HR
	LIQUID	VAPOR	LIQUID	VAPOR	MIXED	LIQUID
VAPOR						
12	0.9001E+06	0.1041E+07				
19	0.2334E+06	0.1839E+06				
20	0.4794E+05	0.1855E+06				.47936+05

**** MOLE-X-PROFILE ****

STAGE	TDA	O2	CO	TDI	WATER
1	0.0000	0.42723E-03	0.29247E-01	0.0000	
0.94943E-06					
2	0.0000	0.12380E-05	0.43754E-04	0.0000	
0.57336E-05					
3	0.0000	0.56583E-06	0.19954E-04	0.0000	
0.20730E-04					
4	0.0000	0.56769E-06	0.20037E-04	0.0000	
0.67837E-04					
5	0.0000	0.57364E-06	0.20259E-04	0.0000	
0.21481E-03					
9	0.12837E-13	0.12191E-05	0.46968E-04	0.22419E-07	
0.18800E-01					
10	0.24414E-09	0.32971E-05	0.13921E-03	0.62843E-04	
0.53065E-01					
11	0.71727E-06	0.24558E-06	0.68582E-05	0.19400E-01	0.10811
12	0.74171E-06	0.31911E-07	0.58985E-06	0.20061E-01	0.27257
19	0.81779E-06	0.0000	0.0000	0.23060E-01	0.97694
20	0.12310E-04	0.0000	0.0000	0.33287	0.66712

**** MOLE-X-PROFILE ****

STAGE	SOLVENT
1	0.97032
2	0.99995
3	0.99996
4	0.99991
5	0.99976
9	0.98115
10	0.94673
11	0.87248
12	0.70737
19	0.10895E-05
20	0.14271E-06

**** MOLE-Y-PROFILE ****

STAGE	TDA	O2	CO	TDI	WATER
-------	-----	----	----	-----	-------

Phosgene-Free Route to Toluene Diisocyanate

Bou-Saba, Dizon, Kasih, Stewart

1	0.0000	0.71858E-02	0.82158	0.0000	
0.41853E-08					
2	0.0000	0.42723E-03	0.29247E-01	0.0000	
0.94943E-06					
3	0.0000	0.19746E-03	0.13496E-01	0.0000	
0.35298E-05					
4	0.0000	0.19697E-03	0.13474E-01	0.0000	
0.11624E-04					
5	0.0000	0.19699E-03	0.13476E-01	0.0000	
0.37043E-04					
9	0.0000	0.19742E-03	0.13502E-01	0.40542E-11	
0.34015E-02					
10	0.69020E-14	0.19818E-03	0.13547E-01	0.12054E-07	
0.10109E-01					
11	0.23968E-10	0.51089E-05	0.21737E-03	0.43295E-05	
0.23201E-01					
12	0.41475E-10	0.26077E-06	0.72825E-05	0.56554E-05	
0.73525E-01					
19	0.82880E-08	0.0000	0.0000	0.80086E-04	0.99991
20	0.39588E-07	0.0000	0.0000	0.20806E-02	0.99792

ASPEN PLUS PLAT: WIN32 VER: 23.0
25

04/07/2010 PAGE

U-O-S BLOCK SECTION

BLOCK: D-101 MODEL: RADFRAC (CONTINUED)

**** MOLE-Y-PROFILE ****

STAGE	SOLVENT
1	0.17124
2	0.97032
3	0.98630
4	0.98632
5	0.98629
9	0.98290
10	0.97615
11	0.97657
12	0.92646
19	0.10788E-04
20	0.11536E-05

**** K-VALUES ****

STAGE	TDA	O2	CO	TDI	WATER
1	0.15481E-06	16.820	28.091	0.20164E-05	
0.44076E-02					
2	0.19365E-04	345.12	668.50	0.14623E-03	0.16559
3	0.20644E-04	349.01	676.38	0.15470E-03	0.17027
4	0.21251E-04	346.97	672.46	0.15849E-03	0.17136
5	0.21865E-04	343.41	665.17	0.16229E-03	0.17244
9	0.25401E-04	162.07	287.73	0.18084E-03	0.18093
10	0.28267E-04	60.210	97.497	0.19181E-03	0.19049
11	0.33396E-04	20.879	31.815	0.22315E-03	0.21458
12	0.55817E-04	8.1887	12.371	0.28177E-03	0.26971
19	0.10133E-01	1143.3	2133.7	0.34730E-02	1.0235
20	0.32159E-02	1258.1	2337.6	0.62504E-02	1.4959

**** K-VALUES ****

STAGE	SOLVENT
1	0.17649
2	0.97044
3	0.98640
4	0.98641
5	0.98652
9	1.0018
10	1.0311
11	1.1194
12	1.3099
19	9.9009
20	8.0842

**** MASS-X-PROFILE ****

STAGE	TDA	O2	CO	TDI	WATER
1	0.0000	0.13963E-03	0.83676E-02	0.0000	
0.17470E-06					

Phosgene-Free Route to Toluene Diisocyanate

Bou-Saba, Dizon, Kasih, Stewart

2	0.0000	0.39600E-06	0.12251E-04	0.0000	
0.10325E-05					
3	0.0000	0.18099E-06	0.55872E-05	0.0000	
0.37332E-05					
4	0.0000	0.18159E-06	0.56106E-05	0.0000	
0.12217E-04					
5	0.0000	0.18352E-06	0.56734E-05	0.0000	
0.38691E-04					
9	0.15922E-13	0.39607E-06	0.13357E-04	0.39641E-07	
0.34386E-02					
10	0.31173E-09	0.11026E-05	0.40752E-04	0.11439E-03	
0.99912E-02					
11	0.94621E-06	0.84852E-07	0.20743E-05	0.36482E-01	
0.21031E-01					
12	0.11446E-05	0.12898E-07	0.20869E-06	0.44131E-01	
0.62024E-01					
19	0.46220E-05	0.0000	0.0000	0.18579	0.81420

ASPEN PLUS PLAT: WIN32 VER: 23.0
26

04/07/2010 PAGE

U-O-S BLOCK SECTION

BLOCK: D-101 MODEL: RADFRAC (CONTINUED)

STAGE	TDA	O2	CO	TDI	WATER
20	0.21487E-04	0.0000	0.0000	0.82827	0.17171

STAGE	SOLVENT
1	0.99149
2	0.99999
3	0.99999
4	0.99998
5	0.99996
9	0.99655
10	0.98985
11	0.94248
12	0.89384
19	0.50424E-05
20	0.20397E-06

STAGE	TDA	O2	CO	TDI	WATER
1	0.0000	0.56953E-02	0.57000	0.0000	
0.18675E-08					
2	0.0000	0.13963E-03	0.83676E-02	0.0000	
0.17470E-06					
3	0.0000	0.63789E-04	0.38163E-02	0.0000	
0.64198E-06					
4	0.0000	0.63630E-04	0.38101E-02	0.0000	
0.21142E-05					
5	0.0000	0.63638E-04	0.38106E-02	0.0000	
0.67373E-05					
9	0.0000	0.63954E-04	0.38287E-02	0.71484E-11	
0.62039E-03					
10	0.85848E-14	0.64562E-04	0.38633E-02	0.21373E-07	
0.18541E-02					
11	0.29842E-10	0.16661E-05	0.62051E-04	0.76846E-05	
0.42597E-02					
12	0.53899E-10	0.88761E-07	0.21698E-05	0.10477E-04	
0.14090E-01					
19	0.56163E-07	0.0000	0.0000	0.77364E-03	0.99917
20	0.26370E-06	0.0000	0.0000	0.19757E-01	0.98024

STAGE	SOLVENT
1	0.42430
2	0.99149
3	0.99612
4	0.99612

5	0.99612
9	0.99549
10	0.99422
11	0.99567
12	0.98590
19	0.59861E-04
20	0.62928E-05

U-O-S BLOCK SECTION

BLOCK: D-101 MODEL: RADFRAC (CONTINUED)

***** HYDRAULIC PARAMETERS *****

*** DEFINITIONS ***

MARANGONI INDEX = SIGMA - SIGMATO
 FLOW PARAM = (ML/MV) * SQRT (RHOV/RHOL)
 QR = QV * SQRT (RHOV / (RHOL - RHOV))
 F FACTOR = QV * SQRT (RHOV)

WHERE:

SIGMA IS THE SURFACE TENSION OF LIQUID FROM THE STAGE
 SIGMATO IS THE SURFACE TENSION OF LIQUID TO THE STAGE
 ML IS THE MASS FLOW OF LIQUID FROM THE STAGE
 MV IS THE MASS FLOW OF VAPOR TO THE STAGE
 RHOL IS THE MASS DENSITY OF LIQUID FROM THE STAGE
 RHOV IS THE MASS DENSITY OF VAPOR TO THE STAGE
 QV IS THE VOLUMETRIC FLOW RATE OF VAPOR TO THE STAGE

TEMPERATURE
F

STAGE	LIQUID FROM	VAPOR TO
1	34.092	93.227
2	93.227	94.954
3	94.954	96.030
4	96.030	97.085
5	97.085	98.125
9	101.66	103.76
10	103.76	112.01
11	108.02	115.57
12	115.57	132.82
19	181.88	200.71
20	200.71	200.71

STAGE	MASS FLOW LB/HR		VOLUME FLOW CUFT/HR		MOLECULAR WEIGHT	
	LIQUID FROM	VAPOR TO	LIQUID FROM	VAPOR TO	LIQUID FROM	VAPOR
1	0.19075E+07	0.19075E+07	18769.	0.22486E+08	97.905	97.905
2	0.11133E+07	0.20438E+07	11333.	0.23195E+08	100.04	99.055
3	0.11146E+07	0.20452E+07	11367.	0.22605E+08	100.04	99.056
4	0.11144E+07	0.20449E+07	11377.	0.22029E+08	100.03	99.053
5	0.11140E+07	0.20445E+07	11386.	0.21483E+08	100.02	99.047

Phosgene-Free Route to Toluene Diisocyanate

Bou-Saba, Dizon, Kasih, Stewart

9	0.10887E+07	0.20192E+07	11217.	0.19540E+08	98.495	98.222
10	0.10329E+07	0.19634E+07	10735.	0.19587E+08	95.682	96.723
11	0.10886E+07	0.10407E+07	11536.	0.10257E+08	92.610	94.009
12	0.90011E+06	0.85217E+06	9958.3	0.99849E+07	79.170	79.758
19	0.23343E+06	0.18549E+06	3937.7	0.91527E+07	21.616	18.340
20	47936.	0.18549E+06	709.86	0.91527E+07	69.992	18.340

ASPEN PLUS PLAT: WIN32 VER: 23.0
28

04/07/2010 PAGE

U-O-S BLOCK SECTION

BLOCK: D-101 MODEL: RADFRAC (CONTINUED)

STAGE	DENSITY LB/CUFT		VISCOSITY CP		SURFACE TENSION DYNE/CM	
	LIQUID	FROM VAPOR TO	LIQUID	FROM VAPOR TO	LIQUID	FROM
1	101.63	0.84833E-01	0.45531	0.12204E-01	31.145	
2	98.231	0.88113E-01	0.39955	0.12176E-01	26.139	
3	98.061	0.90474E-01	0.39731	0.12198E-01	25.966	
4	97.952	0.92828E-01	0.39592	0.12219E-01	25.860	
5	97.844	0.95171E-01	0.39459	0.12241E-01	25.760	
9	97.054	0.10333	0.39289	0.12369E-01	26.131	
10	96.224	0.10024	0.39758	0.12559E-01	27.453	
11	94.364	0.10146	0.41601	0.12639E-01	29.941	
12	90.388	0.85346E-01	0.43662	0.13203E-01	36.542	
19	59.280	0.20266E-01	0.34980	0.12341E-01	60.993	
20	67.530	0.20266E-01	0.44089	0.12341E-01	53.020	

STAGE	MARANGONI INDEX	FLOW PARAM	QR	REDUCED F-FACTOR
	DYNE/CM		CUFT/HR	(LB-CUFT)**.5/HR
1		0.28891E-01	0.64992E+06	0.65492E+07
2	-5.0068	0.16314E-01	0.69500E+06	0.68852E+07
3	-.17269	0.16555E-01	0.68694E+06	0.67993E+07
4	-.10634	0.16776E-01	0.67847E+06	0.67117E+07
5	-.99691E-01	0.16994E-01	0.67032E+06	0.66273E+07
9	0.42096	0.17593E-01	0.63793E+06	0.62813E+07
10	1.3220	0.16980E-01	0.63253E+06	0.62015E+07
11	1.8600	0.34301E-01	0.33651E+06	0.32671E+07
12	6.6010	0.32457E-01	0.30696E+06	0.29170E+07
19	-.14622	0.23268E-01	0.16926E+06	0.13030E+07
20	-7.9724	0.44769E-02	0.15858E+06	0.13030E+07

U-O-S BLOCK SECTION

BLOCK: D-101 MODEL: RADFRAC (CONTINUED)

***** PACKING SIZING CALCULATIONS *****

*** SECTION 1 ***

STARTING STAGE NUMBER		2
ENDING STAGE NUMBER		19
CAPACITY CALCULATION METHOD		KOCH
PRESSURE DROP CALCULATION METHOD		KOCH
LIQUID HOLDUP CALCULATION METHOD		STICHL
PRESSURE PROFILE UPDATED		NO

DESIGN PARAMETERS

OVERDESIGN FACTOR		1.00000
SYSTEM FOAMING FACTOR		1.00000
FRAC. APP. TO MAXIMUM CAPACITY		0.85000
MAXIMUM CAPACITY FACTOR	FT/SEC	MISSING
DESIGN CAPACITY FACTOR	FT/SEC	MISSING
PRESSURE DROP FOR THE SECTION	PSI	MISSING
PRESSURE DROP PER UNIT HEIGHT	IN-WATER/FT	MISSING

PACKING SPECIFICATIONS

PACKING TYPE		FLEXIPAC
PACKING MATERIAL		METAL
PACKING SIZE		500Y
VENDOR		KOCH
PACKING FACTOR	1/FT	67.6917
PACKING SURFACE AREA	SQFT/CUF	152.402
PACKING VOID FRACTION		0.92000
FIRST STICHLMAIR CONSTANT		0.77242
SECOND STICHLMAIR CONSTANT		-0.10883
THIRD STICHLMAIR CONSTANT		0.11184
HETP	FT	1.33333
PACKING HEIGHT	FT	24.0000

***** SIZING RESULTS *****

COLUMN DIAMETER	FT	32.8152
MAXIMUM FRACTIONAL CAPACITY		0.85000

MAXIMUM CAPACITY FACTOR	FT/SEC	0.22827
PRESSURE DROP FOR THE SECTION	PSI	0.30464
AVERAGE PRESSURE DROP/HEIGHT	IN-WATER/FT	0.35134
MAXIMUM LIQUID HOLDUP/STAGE	CUFT	29.0714
MAX LIQ SUPERFICIAL VELOCITY	FT/SEC	0.0037890

ASPEN PLUS PLAT: WIN32 VER: 23.0
30

04/07/2010 PAGE

U-O-S BLOCK SECTION

BLOCK: D-101 MODEL: RADFRAC (CONTINUED)

**** RATING PROFILES AT MAXIMUM COLUMN DIAMETER ****

STAGE	HEIGHT FROM TOP OF SECTION FT	FRACTIONAL CAPACITY	PRESSURE DROP PSI	PRESSURE DROP/HEIGHT IN-WATER/FT	LIQUID HOLDUP CUFT	HETP FT
2	0.000	0.8500	0.37981E-01	0.78849	28.75	
1.333						
3	1.333	0.8414	0.36240E-01	0.75235	28.81	
1.333						
4	2.667	0.8322	0.34495E-01	0.71612	28.83	
1.333						
5	4.000	0.8233	0.32928E-01	0.68359	28.84	
1.333						
6	5.333	0.8147	0.31499E-01	0.65391	28.85	
1.333						
7	6.667	0.8061	0.30151E-01	0.62592	28.84	
1.333						
8	8.000	0.7971	0.28776E-01	0.59738	28.77	
1.333						
9	9.333	0.7864	0.27146E-01	0.56356	28.55	
1.333						
10	10.67	0.7768	0.25440E-01	0.52814	27.72	
1.333						
11	12.00	0.4513	0.61637E-02	0.12796	29.07	
1.333						
12	13.33	0.4086	0.48550E-02	0.10079	26.36	
1.333						
13	14.67	0.3266	0.28247E-02	0.58641E-01	20.83	
1.333						
14	16.00	0.2429	0.13221E-02	0.27446E-01	15.45	
1.333						
15	17.33	0.2216	0.10182E-02	0.21137E-01	14.26	
1.333						
16	18.67	0.2177	0.96932E-03	0.20123E-01	14.14	
1.333						
17	20.00	0.2159	0.94935E-03	0.19708E-01	14.13	
1.333						
18	21.33	0.2143	0.93303E-03	0.19370E-01	14.14	
1.333						
19	22.67	0.2153	0.94252E-03	0.19567E-01	14.20	
1.333						

LIQUID
SUPERFICIAL
STAGE VELOCITY

	FT/SEC
2	0.3722E-02
3	0.3733E-02
4	0.3737E-02
5	0.3740E-02
6	0.3741E-02
7	0.3739E-02
8	0.3727E-02
9	0.3684E-02
10	0.3526E-02
11	0.3789E-02
12	0.3271E-02
13	0.2298E-02
14	0.1468E-02
15	0.1302E-02
16	0.1285E-02
17	0.1284E-02
18	0.1285E-02
19	0.1293E-02

ASPEN PLUS PLAT: WIN32 VER: 23.0
31

04/07/2010 PAGE

U-O-S BLOCK SECTION

BLOCK: D-101 MODEL: RADFRAC (CONTINUED)

***** TRAY SIZING CALCULATIONS *****

*** SECTION 1 ***

STARTING STAGE NUMBER 2
ENDING STAGE NUMBER 19
FLOODING CALCULATION METHOD B960

DESIGN PARAMETERS

PEAK CAPACITY FACTOR 1.00000
SYSTEM FOAMING FACTOR 1.00000
FLOODING FACTOR 0.80000
MINIMUM COLUMN DIAMETER FT 1.00000
MINIMUM DC AREA/COLUMN AREA 0.100000

TRAY SPECIFICATIONS

TRAY TYPE FLEXI
NUMBER OF PASSES 4
TRAY SPACING FT 2.00000

***** SIZING RESULTS @ STAGE WITH MAXIMUM DIAMETER *****

STAGE WITH MAXIMUM DIAMETER 2
COLUMN DIAMETER FT 30.3522
DC AREA/COLUMN AREA 0.100000
SIDE DOWNCOMER VELOCITY FT/SEC 0.043509
SIDE WEIR LENGTH FT 14.5095

**** SIZING PROFILES ****

STAGE	DIAMETER	TOTAL AREA	ACTIVE AREA	SIDE DC AREA
	FT	SQFT	PER PANEL	PER PANEL
			SQFT	SQFT
2	30.352	723.55	144.71	18.089
3	30.194	716.01	143.20	17.900
4	30.019	707.76	141.55	17.694
5	29.850	699.81	139.96	17.495

Phosgene-Free Route to Toluene Diisocyanate

Bou-Saba, Dizon, Kasih, Stewart

6	29.684	692.06	138.41	17.301
7	29.517	684.30	136.86	17.107
8	29.338	676.00	135.20	16.900
9	29.112	665.65	133.13	16.641
10	28.866	654.44	130.89	16.361
11	21.587	366.01	73.201	9.1502

ASPEN PLUS PLAT: WIN32 VER: 23.0
32

04/07/2010 PAGE

U-O-S BLOCK SECTION

BLOCK: D-101 MODEL: RADFRAC (CONTINUED)

STAGE	DIAMETER	TOTAL AREA	ACTIVE AREA	SIDE DC AREA
	FT	SQFT	PER PANEL SQFT	PER PANEL SQFT
12	20.329	324.57	64.914	8.1143
13	17.834	249.79	49.957	6.2447
14	15.128	179.74	35.948	4.4935
15	14.394	162.73	32.547	4.0683
16	14.257	159.64	31.928	3.9910
17	14.191	158.17	31.635	3.9543
18	14.135	156.91	31.382	3.9228
19	14.171	157.72	31.544	3.9430

BLOCK: D-102 MODEL: RADFRAC

INLETS - S-112 STAGE 5
OUTLETS - S-115 STAGE 1
S-113 STAGE 12

PROPERTY OPTION SET: NRTL-RK RENON (NRTL) / REDLICH-KWONG

*** MASS AND ENERGY BALANCE ***

	IN	OUT	RELATIVE
DIFF.			
TOTAL BALANCE			
MOLE (LBMOL/HR)	684.886	684.886	0.00000
MASS (LB/HR)	47936.4	47936.4	0.546421E-
14			
ENTHALPY (BTU/HR)	-0.658998E+08	-0.643408E+08	-0.236565E-
01			

ASPEN PLUS PLAT: WIN32 VER: 23.0
33

04/07/2010 PAGE

U-O-S BLOCK SECTION

BLOCK: D-102 MODEL: RADFRAC (CONTINUED)

**** INPUT DATA ****

**** INPUT PARAMETERS ****

NUMBER OF STAGES	12
ALGORITHM OPTION	STANDARD
ABSORBER OPTION	NO
INITIALIZATION OPTION	STANDARD
HYDRAULIC PARAMETER CALCULATIONS	NO
INSIDE LOOP CONVERGENCE METHOD	BROYDEN
DESIGN SPECIFICATION METHOD	NESTED
MAXIMUM NO. OF OUTSIDE LOOP ITERATIONS	25
MAXIMUM NO. OF INSIDE LOOP ITERATIONS	10
MAXIMUM NUMBER OF FLASH ITERATIONS	50
FLASH TOLERANCE	0.000100000
OUTSIDE LOOP CONVERGENCE TOLERANCE	0.000100000

**** COL-SPECS ****

MOLAR VAPOR DIST / TOTAL DIST	0.0
MOLAR REFLUX RATIO	0.0070000
MOLAR DISTILLATE RATE	LBMOL/HR 456.905

**** PROFILES ****

P-SPEC	STAGE 1	PRES, PSIA	1.00000
--------	---------	------------	---------

**** RESULTS ****

*** COMPONENT SPLIT FRACTIONS ***

	OUTLET STREAMS	
	S-115	S-113
COMPONENT:	-----	
TDA	.76687E-04	.99992
TDI	.11883E-02	.99881
WATER	.99942	.58416E-03
SOLVENT	1.0000	.67174E-09

ASPEN PLUS PLAT: WIN32 VER: 23.0 04/07/2010 PAGE 34

U-O-S BLOCK SECTION

BLOCK: D-102 MODEL: RADFRAC (CONTINUED)

*** SUMMARY OF KEY RESULTS ***

TOP STAGE TEMPERATURE	F	101.705
BOTTOM STAGE TEMPERATURE	F	352.201
TOP STAGE LIQUID FLOW	LBMOL/HR	3.19833
BOTTOM STAGE LIQUID FLOW	LBMOL/HR	227.981
TOP STAGE VAPOR FLOW	LBMOL/HR	0.0
BOILUP VAPOR FLOW	LBMOL/HR	293.054
MOLAR REFLUX RATIO		0.0070000
MOLAR BOILUP RATIO		1.28543
CONDENSER DUTY (W/O SUBCOOL)	BTU/HR	-8,628,050.
REBOILER DUTY	BTU/HR	0.101869+08

**** MAXIMUM FINAL RELATIVE ERRORS ****

DEW POINT	0.23692E-03	STAGE= 11
BUBBLE POINT	0.18336E-03	STAGE= 11
COMPONENT MASS BALANCE	0.81103E-05	STAGE= 4 COMP=TDI
ENERGY BALANCE	0.30211E-03	STAGE= 11

**** PROFILES ****

NOTE REPORTED VALUES FOR STAGE LIQUID AND VAPOR RATES ARE THE FLOWS FROM THE STAGE EXCLUDING ANY SIDE PRODUCT. FOR THE FIRST STAGE, THE REPORTED VAPOR FLOW IS THE VAPOR DISTILLATE FLOW. FOR THE LAST STAGE, THE REPORTED LIQUID FLOW IS THE LIQUID BOTTOMS FLOW.

STAGE	TEMPERATURE F	PRESSURE PSIA	ENTHALPY BTU/LBMOL		HEAT DUTY BTU/HR
			LIQUID	VAPOR	
1	101.70	1.0000	-0.12237E+06	-0.10377E+06	-.86281+07
2	114.50	1.0077	-0.10078E+06	-0.10362E+06	
3	125.29	1.1077	-91420.	-0.10348E+06	
4	127.19	1.2077	-92769.	-0.10347E+06	
5	128.03	1.3077	-95156.	-0.10347E+06	
6	130.69	1.4077	-95178.	-0.10345E+06	
8	135.56	1.6077	-95212.	-0.10340E+06	
9	137.89	1.7077	-95123.	-0.10338E+06	
10	147.84	1.8077	-86894.	-0.10323E+06	
11	264.38	1.9077	-46463.	-90438.	
12	352.20	2.0077	-36978.	-19082.	.10187+08

ASPEN PLUS PLAT: WIN32 VER: 23.0
35

04/07/2010 PAGE

U-O-S BLOCK SECTION

BLOCK: D-102 MODEL: RADFRAC (CONTINUED)

STAGE	FLOW RATE		FEED RATE			PRODUCT RATE
	LBMOL/HR		LBMOL/HR			LBMOL/HR
	LIQUID	VAPOR	LIQUID	VAPOR	MIXED	LIQUID
VAPOR						
1	3.198	0.000				456.9050
2	0.9394	460.1				
3	0.5934	457.8				
4	0.4654	457.5		85.9955		
5	598.9	371.4	598.8904			
6	601.4	371.0				
8	605.8	375.7				
9	606.5	377.8				
10	563.7	378.5				
11	521.0	335.7				
12	228.0	293.1				227.9810

**** MASS FLOW PROFILES ****

STAGE	FLOW RATE		FEED RATE			PRODUCT RATE
	LB/HR		LB/HR			LB/HR
	LIQUID	VAPOR	LIQUID	VAPOR	MIXED	LIQUID
VAPOR						
1	57.92	0.000				8273.5781
2	61.88	8331.				
3	51.02	8335.				
4	38.56	8325.		1562.8473		
5	0.4641E+05	6749.	.46374+05			
6	0.4645E+05	6744.				
8	0.4654E+05	6834.				
9	0.4660E+05	6875.				
10	0.5309E+05	6942.				
11	0.8719E+05	0.1343E+05				
12	0.3966E+05	0.4752E+05				.39663+05

**** MOLE-X-PROFILE ****

STAGE	TDA	TDI	WATER	SOLVENT
1	0.14150E-08	0.59289E-03	0.99941	0.21391E-06
2	0.17344E-05	0.30648	0.69352	0.20262E-07
3	0.61773E-05	0.43526	0.56473	0.19473E-07
4	0.11091E-04	0.41515	0.58484	0.19954E-07
5	0.14083E-04	0.38083	0.61916	0.10126E-07
6	0.14026E-04	0.37929	0.62070	0.15836E-08
8	0.13925E-04	0.37658	0.62340	0.39409E-10
9	0.13912E-04	0.37676	0.62323	0.62633E-11
10	0.15417E-04	0.48783	0.51215	0.92269E-12
11	0.22182E-04	0.95626	0.43719E-01	0.24151E-13
12	0.36978E-04	0.99879	0.11707E-02	0.0000

ASPEN PLUS PLAT: WIN32 VER: 23.0
36

04/07/2010 PAGE

U-O-S BLOCK SECTION

BLOCK: D-102 MODEL: RADFRAC (CONTINUED)

**** MOLE-Y-PROFILE ****				
STAGE	TDA	TDI	WATER	SOLVENT
1	0.68136E-11	0.64643E-06	1.0000	0.31616E-05
2	0.14150E-08	0.59289E-03	0.99941	0.21391E-06
3	0.49710E-08	0.12205E-02	0.99878	0.21351E-06
4	0.94257E-08	0.11567E-02	0.99884	0.21366E-06
5	0.12702E-07	0.10151E-02	0.99898	0.10549E-06
6	0.13306E-07	0.10489E-02	0.99895	0.16349E-07
8	0.14468E-07	0.11130E-02	0.99889	0.40029E-09
9	0.15058E-07	0.11517E-02	0.99885	0.63187E-10
10	0.18003E-07	0.20804E-02	0.99792	0.10036E-10
11	0.77530E-06	0.14085	0.85915	0.15491E-11
12	0.10672E-04	0.92317	0.76820E-01	0.42715E-13

**** K-VALUES ****				
STAGE	TDA	TDI	WATER	SOLVENT
1	0.48151E-02	0.10903E-02	1.0006	14.780
2	0.81590E-03	0.19345E-02	1.4411	10.558
3	0.80507E-03	0.28034E-02	1.7686	10.967
4	0.84999E-03	0.27859E-02	1.7079	10.709
5	0.90190E-03	0.26655E-02	1.6135	10.417
6	0.94832E-03	0.27655E-02	1.6094	10.323
8	0.10386E-02	0.29556E-02	1.6023	10.156
9	0.10819E-02	0.30566E-02	1.6027	10.088
10	0.11657E-02	0.42634E-02	1.9487	10.874
11	0.34970E-01	0.14733	19.647	64.109
12	0.28860	0.92426	65.621	148.35

**** MASS-X-PROFILE ****				
STAGE	TDA	TDI	WATER	SOLVENT
1	0.95469E-08	0.57023E-02	0.99430	0.11818E-05
2	0.32169E-05	0.81032	0.18968	0.30772E-07
3	0.87775E-05	0.88166	0.11833	0.22658E-07
4	0.16357E-04	0.87280	0.12719	0.24097E-07
5	0.22206E-04	0.85602	0.14396	0.13075E-07
6	0.22185E-04	0.85521	0.14477	0.20511E-08
8	0.22146E-04	0.85378	0.14620	0.51322E-10
9	0.22117E-04	0.85387	0.14611	0.81538E-11
10	0.19997E-04	0.90202	0.97959E-01	0.98001E-12
11	0.16196E-04	0.99528	0.47069E-02	0.14439E-13
12	0.25967E-04	0.99985	0.12123E-03	0.0000

**** MASS-Y-PROFILE ****				
STAGE	TDA	TDI	WATER	SOLVENT
1	0.46205E-10	0.62491E-05	0.99998	0.17556E-04
2	0.95469E-08	0.57023E-02	0.99430	0.11818E-05
3	0.33358E-07	0.11676E-01	0.98832	0.11732E-05

Phosgene-Free Route to Toluene Diisocyanate

Bou-Saba, Dizon, Kasih, Stewart

4	0.63286E-07	0.11071E-01	0.98893	0.11747E-05
5	0.85389E-07	0.97274E-02	0.99027	0.58066E-06
6	0.89419E-07	0.10048E-01	0.98995	0.89972E-07
8	0.97178E-07	0.10657E-01	0.98934	0.22016E-08
9	0.10111E-06	0.11024E-01	0.98898	0.34742E-09
10	0.11992E-06	0.19755E-01	0.98024	0.54742E-10
11	0.23675E-05	0.61314	0.38686	0.38734E-11

U-O-S BLOCK SECTION

BLOCK: D-102 MODEL: RADFRAC (CONTINUED)

STAGE	TDA	TDI	WATER	SOLVENT
12	0.80404E-05	0.99146	0.85342E-02	0.26352E-13

***** HYDRAULIC PARAMETERS *****

*** DEFINITIONS ***

MARANGONI INDEX = SIGMA - SIGMATO
 FLOW PARAM = (ML/MV) * SQRT (RHOV/RHOL)
 QR = QV * SQRT (RHOV / (RHOL - RHOV))
 F FACTOR = QV * SQRT (RHOV)

WHERE:

SIGMA IS THE SURFACE TENSION OF LIQUID FROM THE STAGE
 SIGMATO IS THE SURFACE TENSION OF LIQUID TO THE STAGE
 ML IS THE MASS FLOW OF LIQUID FROM THE STAGE
 MV IS THE MASS FLOW OF VAPOR TO THE STAGE
 RHOL IS THE MASS DENSITY OF LIQUID FROM THE STAGE
 RHOV IS THE MASS DENSITY OF VAPOR TO THE STAGE
 QV IS THE VOLUMETRIC FLOW RATE OF VAPOR TO THE STAGE

TEMPERATURE

STAGE	LIQUID FROM	VAPOR TO
1	101.70	114.50
2	114.50	125.29
3	125.29	127.19
4	127.19	128.00
5	128.03	130.69
6	130.69	133.19
8	135.56	137.89
9	137.89	147.84
10	147.84	264.38
11	264.38	352.20
12	352.20	352.20

MASS FLOW
LB/HR

VOLUME FLOW
CUFT/HR

MOLECULAR WEIGHT

STAGE	LIQUID FROM	VAPOR TO	LIQUID FROM	VAPOR TO	LIQUID FROM	VAPOR
TO						
1	8331.5	8331.5	136.04	0.28112E+07	18.108	18.108
2	61.881	8335.5	0.87821	0.25926E+07	65.870	18.206
3	51.021	8324.6	0.71309	0.23837E+07	85.979	18.196
4	38.557	8312.1	0.54085	0.23863E+07	82.840	18.174
5	46406.	6743.7	654.51	0.16679E+07	77.481	18.179
6	46453.	6790.5	656.24	0.15742E+07	77.240	18.184
8	46538.	6874.8	659.41	0.14172E+07	76.818	18.195

ASPEN PLUS PLAT: WIN32 VER: 23.0
38

04/07/2010 PAGE

U-O-S BLOCK SECTION

BLOCK: D-102 MODEL: RADFRAC (CONTINUED)

STAGE	MASS FLOW LB/HR		VOLUME FLOW CUFT/HR		MOLECULAR WEIGHT	
	LIQUID FROM	VAPOR TO	LIQUID FROM	VAPOR TO	LIQUID FROM	VAPOR
9	46604.	6941.5	661.16	0.13634E+07	76.845	18.340
10	53095.	13432.	746.15	0.13657E+07	94.189	40.009
11	87185.	47523.	1264.6	0.12651E+07	167.33	162.16
12	39663.	47523.	604.58	0.12651E+07	173.97	162.16

STAGE	DENSITY LB/CUFT		VISCOSITY CP		SURFACE TENSION DYNE/CM	
	LIQUID FROM	VAPOR TO	LIQUID FROM	VAPOR TO	LIQUID FROM	
1	61.245	0.29637E-02	0.68816	0.10558E-01	70.079	
2	70.463	0.32151E-02	0.84215	0.10778E-01	62.190	
3	71.549	0.34923E-02	0.87553	0.10817E-01	58.392	
4	71.290	0.34833E-02	0.84165	0.10834E-01	58.626	
5	70.903	0.40433E-02	0.80427	0.10889E-01	59.262	
6	70.787	0.43137E-02	0.78393	0.10941E-01	59.030	
8	70.574	0.48509E-02	0.74878	0.11037E-01	58.602	
9	70.489	0.50913E-02	0.73401	0.11239E-01	58.367	
10	71.159	0.98352E-02	0.76486	0.12587E-01	55.106	
11	68.945	0.37563E-01	0.64833	0.87263E-02	35.773	
12	65.604	0.37563E-01	0.46010	0.87263E-02	28.187	

STAGE	MARANGONI INDEX DYNE/CM	FLOW PARAM	QR CUFT/HR	REDUCED F-FACTOR (LB-CUFT)**.5/HR
1		0.69564E-02	19556.	0.15304E+06
2	-7.8892	0.50147E-04	17513.	0.14700E+06
3	-3.7978	0.42819E-04	16654.	0.14087E+06
4	0.23428	0.32424E-04	16681.	0.14084E+06
5	-.78152E-02	0.51966E-01	12595.	0.10605E+06
6	-.23224	0.53403E-01	12289.	0.10339E+06
8	-.20809	0.56122E-01	11750.	98707.
9	-.23503	0.57059E-01	11588.	97284.
10	-3.2606	0.46472E-01	16057.	0.13544E+06
11	-19.333	0.42823E-01	29538.	0.24520E+06
12	-7.5865	0.19971E-01	30281.	0.24520E+06

U-O-S BLOCK SECTION

BLOCK: D-102 MODEL: RADFRAC (CONTINUED)

***** PACKING SIZING CALCULATIONS *****

*** SECTION 1 ***

STARTING STAGE NUMBER		2
ENDING STAGE NUMBER		7
CAPACITY CALCULATION METHOD		KOCH
PRESSURE DROP CALCULATION METHOD		KOCH
LIQUID HOLDUP CALCULATION METHOD		STICHL
PRESSURE PROFILE UPDATED		NO

DESIGN PARAMETERS

OVERDESIGN FACTOR		1.00000
SYSTEM FOAMING FACTOR		1.00000
FRAC. APP. TO MAXIMUM CAPACITY		0.62000
MAXIMUM CAPACITY FACTOR	FT/SEC	MISSING
DESIGN CAPACITY FACTOR	FT/SEC	MISSING
PRESSURE DROP FOR THE SECTION	PSI	MISSING
PRESSURE DROP PER UNIT HEIGHT	IN-WATER/FT	MISSING

PACKING SPECIFICATIONS

PACKING TYPE		FLEXIPAC
PACKING MATERIAL		METAL
PACKING SIZE		2X
VENDOR		KOCH
PACKING FACTOR	1/FT	15.1792
PACKING SURFACE AREA	SQFT/CUF	68.5808
PACKING VOID FRACTION		0.97000
FIRST STICHLMAIR CONSTANT		0.84405
SECOND STICHLMAIR CONSTANT		-0.098801
THIRD STICHLMAIR CONSTANT		0.33853
HETP	FT	1.50000
PACKING HEIGHT	FT	9.00000

***** SIZING RESULTS *****

COLUMN DIAMETER	FT	3.93165
MAXIMUM FRACTIONAL CAPACITY		0.62000

MAXIMUM CAPACITY FACTOR	FT/SEC	0.40070
PRESSURE DROP FOR THE SECTION	PSI	0.051517
AVERAGE PRESSURE DROP/HEIGHT	IN-WATER/FT	0.15844
MAXIMUM LIQUID HOLDUP/STAGE	CUFT	0.83682
MAX LIQ SUPERFICIAL VELOCITY	FT/SEC	0.015052

ASPEN PLUS PLAT: WIN32 VER: 23.0 04/07/2010 PAGE 40

U-O-S BLOCK SECTION

BLOCK: D-102 MODEL: RADFRAC (CONTINUED)

**** RATING PROFILES AT MAXIMUM COLUMN DIAMETER ****

STAGE	HEIGHT FROM TOP OF SECTION FT	FRACTIONAL CAPACITY	PRESSURE DROP PSI	PRESSURE DROP/HEIGHT IN-WATER/FT	LIQUID HOLDUP CUFT	HETP FT
2	0.000	0.6106	0.10901E-01	0.20116	0.1014E-01	
1.500						
3	1.500	0.5801	0.10009E-01	0.18469	0.8813E-02	
1.500						
4	3.000	0.5802	0.10004E-01	0.18460	0.7330E-02	
1.500						
5	4.500	0.6200	0.72805E-02	0.13435	0.8351	
1.500						
6	6.000	0.6074	0.68487E-02	0.12638	0.8360	
1.500						
7	7.500	0.5958	0.64742E-02	0.11947	0.8368	
1.500						

STAGE	LIQUID SUPERFICIAL VELOCITY FT/SEC
2	0.2009E-04
3	0.1632E-04
4	0.1237E-04
5	0.1498E-01
6	0.1501E-01
7	0.1505E-01

 ***** TRAY SIZING CALCULATIONS *****

 *** SECTION 1 ***

STARTING STAGE NUMBER 2
 ENDING STAGE NUMBER 10
 FLOODING CALCULATION METHOD B960

DESIGN PARAMETERS

PEAK CAPACITY FACTOR		1.00000
SYSTEM FOAMING FACTOR		1.00000
FLOODING FACTOR		0.80000
MINIMUM COLUMN DIAMETER	FT	1.00000
MINIMUM DC AREA/COLUMN AREA		0.100000

TRAY SPECIFICATIONS

TRAY TYPE		FLEXI
NUMBER OF PASSES		4
TRAY SPACING	FT	2.00000

ASPEN PLUS PLAT: WIN32 VER: 23.0 04/07/2010 PAGE 41

U-O-S BLOCK SECTION

BLOCK: D-102 MODEL: RADFRAC (CONTINUED)

***** SIZING RESULTS @ STAGE WITH MAXIMUM DIAMETER *****

STAGE WITH MAXIMUM DIAMETER		2
COLUMN DIAMETER	FT	4.19065
DC AREA/COLUMN AREA		0.100000
SIDE DOWNCOMER VELOCITY	FT/SEC	0.00017687
SIDE WEIR LENGTH	FT	2.00327

**** SIZING PROFILES ****

STAGE	DIAMETER	TOTAL AREA	ACTIVE AREA	SIDE DC AREA
	FT	SQFT	PER PANEL	PER PANEL
			SQFT	SQFT
2	4.1907	13.793	2.7586	0.34482
3	4.0863	13.114	2.6229	0.32786
4	4.0893	13.134	2.6268	0.32835
5	3.6905	10.697	2.1394	0.26742
6	3.6461	10.441	2.0883	0.26103
7	3.6049	10.207	2.0413	0.25516
8	3.5667	9.9915	1.9983	0.24979
9	3.5426	9.8567	1.9713	0.24642
10	4.1747	13.688	2.7376	0.34220

BLOCK: F-100 MODEL: FLASH2

 INLET STREAM: S-102
 OUTLET VAPOR STREAM: S-103
 OUTLET LIQUID STREAM: S-128
 PROPERTY OPTION SET: NRTL-RK RENON (NRTL) / REDLICH-KWONG

	***	MASS AND ENERGY BALANCE	***		
DIFF.		IN	OUT	RELATIVE	
TOTAL BALANCE					
MOLE (LBMOL/HR)		5622.44	5622.44	0.00000	
MASS (LB/HR)		292971.	292971.	0.198681E-	
15					
08		ENTHALPY (BTU/HR)	-0.939393E+09	-0.939393E+09	0.319939E-

ASPEN PLUS PLAT: WIN32 VER: 23.0 04/07/2010 PAGE 42

U-O-S BLOCK SECTION

BLOCK: F-100 MODEL: FLASH2 (CONTINUED)

*** INPUT DATA ***

TWO PHASE PQ FLASH		
PRESSURE DROP	PSI	3.00000
SPECIFIED HEAT DUTY	BTU/HR	0.0
MAXIMUM NO. ITERATIONS		30
CONVERGENCE TOLERANCE		0.000100000

*** RESULTS ***

OUTLET TEMPERATURE	F	99.909
OUTLET PRESSURE	PSIA	644.67
VAPOR FRACTION		0.52499

V-L PHASE EQUILIBRIUM :

COMP	F(I)	X(I)	Y(I)	K(I)
TDA	0.17052E-05	0.35898E-05	0.14385E-12	
0.40071E-07				
O2	0.55224E-02	0.37589E-02	0.71180E-02	
1.8937				
CO	0.65559	0.29165	0.98489	
3.3769				
TDI	0.34859E-04	0.73386E-04	0.20849E-09	
0.28410E-05				
WATER	0.41174E-02	0.86631E-02	0.43061E-05	
0.49705E-03				
TDCARB	0.36533E-08	0.76908E-08	0.69630E-18	
0.90536E-10				
SOLVENT	0.33473	0.69585	0.79909E-02	
0.11484E-01				

BLOCK: H-100 MODEL: HEATER

 INLET STREAM: S-110
 OUTLET STREAM: S-111
 PROPERTY OPTION SET: NRTL-RK RENON (NRTL) / REDLICH-KWONG

*** MASS AND ENERGY BALANCE ***

	IN	OUT	RELATIVE
DIFF.			
TOTAL BALANCE			
MOLE (LBMOL/HR)	10189.1	10189.1	0.00000
MASS (LB/HR)	978444.	978444.	0.00000
ENTHALPY (BTU/HR)	-0.380276E+10	-0.362940E+10	-0.455879E-

01

ASPEN PLUS PLAT: WIN32 VER: 23.0 04/07/2010 PAGE
43

U-O-S BLOCK SECTION

BLOCK: H-100 MODEL: HEATER (CONTINUED)

*** INPUT DATA ***

TWO PHASE TP FLASH
SPECIFIED TEMPERATURE F 120.000
PRESSURE DROP PSI 5.00000
MAXIMUM NO. ITERATIONS 30
CONVERGENCE TOLERANCE
0.000100000

*** RESULTS ***

OUTLET TEMPERATURE F 120.00
OUTLET PRESSURE PSIA 7.0000
HEAT DUTY BTU/HR 0.17336E+09
OUTLET VAPOR FRACTION 0.88703
PRESSURE-DROP CORRELATION PARAMETER 8.9245

V-L PHASE EQUILIBRIUM :

COMP	F(I)	X(I)	Y(I)	K(I)
TDA 0.36735E-04	0.82744E-06	0.73225E-05	0.26899E-09	
O2 22.252	0.39851E-03	0.20075E-04	0.44671E-03	
CO 35.404	0.27281E-01	0.86560E-03	0.30645E-01	
TDI 0.35356E-03	0.22375E-01	0.19751	0.69834E-04	
WATER 0.26500	0.44843E-01	0.12885	0.34145E-01	
SOLVENT 1.3894	0.90510	0.67275	0.93469	

BLOCK: H-101 MODEL: HEATER

INLET STREAM: S-121
OUTLET STREAM: S-122
PROPERTY OPTION SET: NRTL-RK RENON (NRTL) / REDLICH-KWONG

*** MASS AND ENERGY BALANCE ***

DIFF.	IN	OUT	RELATIVE
TOTAL BALANCE			
MOLE (LBMOL/HR)	2750.53	2750.53	0.00000
MASS (LB/HR)	283360.	283360.	0.00000

01 ENTHALPY (BTU/HR) -0.108016E+10 -0.105955E+10 -0.190787E-

ASPEN PLUS PLAT: WIN32 VER: 23.0 04/07/2010 PAGE
44

U-O-S BLOCK SECTION

BLOCK: H-101 MODEL: HEATER (CONTINUED)

*** INPUT DATA ***

TWO PHASE TP FLASH		
SPECIFIED TEMPERATURE	F	248.000
PRESSURE DROP	PSI	5.00000
MAXIMUM NO. ITERATIONS		30
CONVERGENCE TOLERANCE		
0.000100000		

*** RESULTS ***

OUTLET TEMPERATURE	F	248.00
OUTLET PRESSURE	PSIA	648.00
HEAT DUTY	BTU/HR	0.20608E+08
OUTLET VAPOR FRACTION		0.0000
PRESSURE-DROP CORRELATION PARAMETER		38286.

V-L PHASE EQUILIBRIUM :

COMP	F(I)	X(I)	Y(I)	K(I)
TDA	0.15314E-01	0.15314E-01	0.21309E-05	
0.13118E-03				
O2	0.41335E-03	0.41335E-03	0.60506E-02	
13.800				
CO	0.28297E-01	0.28297E-01	0.75595	
25.186				
TDI	0.14512E-05	0.14512E-05	0.81699E-09	
0.53076E-03				
WATER	0.91859E-06	0.91859E-06	0.40932E-07	
0.42010E-01				
TDCARB	0.17168E-01	0.17168E-01	0.28748E-08	
0.15788E-06				
SOLVENT	0.93881	0.93881	0.23799	
0.23900				

BLOCK: H-102 MODEL: HEATER

 INLET STREAM: S-129
 OUTLET STREAM: PSEUDLIQ
 PROPERTY OPTION SET: NRTL-RK RENON (NRTL) / REDLICH-KWONG

*** MASS AND ENERGY BALANCE ***

	IN	OUT	RELATIVE
DIFF.			
TOTAL BALANCE			

Phosgene-Free Route to Toluene Diisocyanate

Bou-Saba, Dizon, Kasih, Stewart

MOLE (LBMOL/HR)	11964.1	11964.1	0.00000
MASS (LB/HR)	0.112468E+07	0.112468E+07	0.00000
ENTHALPY (BTU/HR)	-0.438736E+10	-0.430887E+10	-0.178892E-

01

ASPEN PLUS PLAT: WIN32 VER: 23.0 04/07/2010 PAGE
45

U-O-S BLOCK SECTION

BLOCK: H-102 MODEL: HEATER (CONTINUED)

*** INPUT DATA ***

TWO PHASE TP FLASH
SPECIFIED TEMPERATURE F 248.000
PRESSURE DROP PSI 5.00000
MAXIMUM NO. ITERATIONS 30
CONVERGENCE TOLERANCE
0.000100000

*** RESULTS ***

OUTLET TEMPERATURE F 248.00
OUTLET PRESSURE PSIA 639.67
HEAT DUTY BTU/HR 0.78486E+08
OUTLET VAPOR FRACTION 0.84609E-01
PRESSURE-DROP CORRELATION PARAMETER 1638.6

V-L PHASE EQUILIBRIUM :

COMP	F(I)	X(I)	Y(I)	K(I)
TDA 0.13966E-03	0.63441E-03	0.69304E-03	0.96784E-07	
O2 17.117	0.11757E-02	0.49742E-03	0.85145E-02	
CO 31.551	0.86742E-01	0.24197E-01	0.76343	
TDI 0.55075E-03	0.49334E-02	0.53891E-02	0.29679E-05	
WATER 0.44733E-01	0.74641E-02	0.81204E-02	0.36324E-03	
TDCARB 0.15987E-06	0.19135E-02	0.20903E-02	0.33413E-09	
SOLVENT 0.23742	0.89714	0.95901	0.22769	

BLOCK: H-103 MODEL: HEATER

INLET STREAM: S-131
OUTLET STREAM: S-132
PROPERTY OPTION SET: NRTL-RK RENON (NRTL) / REDLICH-KWONG

*** MASS AND ENERGY BALANCE ***

DIFF.	IN	OUT	RELATIVE
TOTAL BALANCE			

Phosgene-Free Route to Toluene Diisocyanate

Bou-Saba, Dizon, Kasih, Stewart

MOLE (LBMOL/HR)	922.509	922.509	0.00000
MASS (LB/HR)	26522.2	26522.2	0.00000
ENTHALPY (BTU/HR)	-0.440973E+08	-0.431146E+08	-0.222856E-

01

ASPEN PLUS PLAT: WIN32 VER: 23.0 04/07/2010 PAGE 46

U-O-S BLOCK SECTION

BLOCK: H-103 MODEL: HEATER (CONTINUED)

*** INPUT DATA ***

TWO PHASE TP FLASH
 SPECIFIED TEMPERATURE F 248.000
 PRESSURE DROP PSI 5.00000
 MAXIMUM NO. ITERATIONS 30
 CONVERGENCE TOLERANCE
 0.000100000

*** RESULTS ***

OUTLET TEMPERATURE F 248.00
 OUTLET PRESSURE PSIA 639.67
 HEAT DUTY BTU/HR 0.98274E+06
 OUTLET VAPOR FRACTION 1.0000
 PRESSURE-DROP CORRELATION PARAMETER 0.13429E+06

V-L PHASE EQUILIBRIUM :

COMP	F(I)	X(I)	Y(I)	K(I)
TDA 0.16787E-04	0.13808E-12	0.98552E-07	0.13808E-12	
O2 15.404	0.46941E-01	0.36512E-01	0.46941E-01	
CO 27.574	0.94538	0.41079	0.94538	
TDI 0.37966E-03	0.20013E-09	0.63157E-05	0.20013E-09	
WATER 0.22821E-01	0.41333E-05	0.21701E-02	0.41333E-05	
SOLVENT 0.16694	0.76704E-02	0.55052	0.76704E-02	

BLOCK: H-104 MODEL: HEATER

 INLET STREAM: S-130
 OUTLET STREAM: PSEUDVAP
 PROPERTY OPTION SET: NRTL-RK RENON (NRTL) / REDLICH-KWONG

*** MASS AND ENERGY BALANCE ***

DIFF.	IN	OUT	RELATIVE
TOTAL BALANCE			
MOLE (LBMOL/HR)	3303.01	3303.01	0.00000
MASS (LB/HR)	122800.	122800.	0.00000

02 ENTHALPY (BTU/HR) -0.294858E+09 -0.292992E+09 -0.633011E-

ASPEN PLUS PLAT: WIN32 VER: 23.0 04/07/2010 PAGE
47

U-O-S BLOCK SECTION

BLOCK: H-104 MODEL: HEATER (CONTINUED)

*** INPUT DATA ***

TWO PHASE TP FLASH
SPECIFIED TEMPERATURE F 248.000
PRESSURE DROP PSI 5.00000
MAXIMUM NO. ITERATIONS 30
CONVERGENCE TOLERANCE
0.000100000

*** RESULTS ***

OUTLET TEMPERATURE F 248.00
OUTLET PRESSURE PSIA 639.67
HEAT DUTY BTU/HR 0.18665E+07
OUTLET VAPOR FRACTION 1.0000
PRESSURE-DROP CORRELATION PARAMETER 7688.1

V-L PHASE EQUILIBRIUM :

COMP	F(I)	X(I)	Y(I)	K(I)
TDA 0.59891E-04	0.43865E-06	0.10585E-01	0.43865E-06	
O2 7.8302	0.71156E-02	0.13139E-02	0.71156E-02	
CO 13.423	0.86500	0.93175E-01	0.86500	
TDI 0.47549E-03	0.13015E-04	0.39581E-01	0.13015E-04	
WATER 0.35964E-01	0.88935E-03	0.35753E-01	0.88935E-03	
TDCARB 0.11728E-06	0.24178E-08	0.29812E-01	0.24178E-08	
SOLVENT 0.23246	0.12698	0.78978	0.12698	

BLOCK: M-100 MODEL: MIXER

INLET STREAMS: S-116 S-119
OUTLET STREAM: S-121
PROPERTY OPTION SET: NRTL-RK RENON (NRTL) / REDLICH-KWONG

*** MASS AND ENERGY BALANCE ***

DIFF.	IN	OUT	RELATIVE
TOTAL BALANCE			

Phosgene-Free Route to Toluene Diisocyanate

Bou-Saba, Dizon, Kasih, Stewart

	MOLE (LBMOL/HR)	2750.53	2750.53	0.00000
	MASS (LB/HR)	283360.	283360.	0.00000
15	ENTHALPY (BTU/HR)	-0.108016E+10	-0.108016E+10	-0.220725E-

ASPEN PLUS PLAT: WIN32 VER: 23.0 04/07/2010 PAGE 48

U-O-S BLOCK SECTION

BLOCK: M-100 MODEL: MIXER (CONTINUED)

*** INPUT DATA ***

TWO PHASE FLASH
 MAXIMUM NO. ITERATIONS 30
 CONVERGENCE TOLERANCE 0.000100000
 OUTLET PRESSURE: MINIMUM OF INLET STREAM PRESSURES

BLOCK: M-101 MODEL: MIXER

 INLET STREAMS: S-125 S-126 S-128
 OUTLET STREAM: S-129
 PROPERTY OPTION SET: NRTL-RK RENON (NRTL) / REDLICH-KWONG

*** MASS AND ENERGY BALANCE ***

	IN	OUT	RELATIVE
DIFF.			
TOTAL BALANCE			
MOLE (LBMOL/HR)	11964.1	11964.1	0.00000
MASS (LB/HR)	0.112468E+07	0.112468E+07	-0.207019E-
15			
ENTHALPY (BTU/HR)	-0.438736E+10	-0.438736E+10	0.217369E-
15			

*** INPUT DATA ***

TWO PHASE FLASH
 MAXIMUM NO. ITERATIONS 30
 CONVERGENCE TOLERANCE 0.000100000
 OUTLET PRESSURE: MINIMUM OF INLET STREAM PRESSURES

BLOCK: M-102 MODEL: MIXER

 INLET STREAMS: O2MAKEUP S-120
 OUTLET STREAM: S-131
 PROPERTY OPTION SET: NRTL-RK RENON (NRTL) / REDLICH-KWONG

*** MASS AND ENERGY BALANCE ***

	IN	OUT	RELATIVE
DIFF.			
TOTAL BALANCE			
MOLE (LBMOL/HR)	922.509	922.509	0.00000
MASS (LB/HR)	26522.2	26522.2	0.137167E-
15			
ENTHALPY (BTU/HR)	-0.440973E+08	-0.440973E+08	-0.168958E-
15			

ASPEN PLUS PLAT: WIN32 VER: 23.0 04/07/2010 PAGE
49

U-O-S BLOCK SECTION

BLOCK: M-102 MODEL: MIXER (CONTINUED)

*** INPUT DATA ***

TWO PHASE FLASH
 MAXIMUM NO. ITERATIONS 30
 CONVERGENCE TOLERANCE 0.000100000
 OUTLET PRESSURE: MINIMUM OF INLET STREAM PRESSURES

BLOCK: M-103 MODEL: MIXER

INLET STREAMS: S-127 S-124
 OUTLET STREAM: S-130
 PROPERTY OPTION SET: NRTL-RK RENON (NRTL) / REDLICH-KWONG

*** MASS AND ENERGY BALANCE ***

	IN	OUT	RELATIVE
DIFF.			
TOTAL BALANCE			
MOLE (LBMOL/HR)	3303.01	3303.01	0.00000
MASS (LB/HR)	122800.	122800.	0.00000
ENTHALPY (BTU/HR)	-0.294858E+09	-0.294858E+09	0.00000

*** INPUT DATA ***

TWO PHASE FLASH
 MAXIMUM NO. ITERATIONS 30
 CONVERGENCE TOLERANCE 0.000100000
 OUTLET PRESSURE: MINIMUM OF INLET STREAM PRESSURES

BLOCK: P-100 MODEL: PUMP

INLET STREAM: S-106
 OUTLET STREAM: S-107
 PROPERTY OPTION SET: NRTL-RK RENON (NRTL) / REDLICH-KWONG

*** MASS AND ENERGY BALANCE ***

	IN	OUT	RELATIVE
DIFF.			
TOTAL BALANCE			
MOLE (LBMOL/HR)	90.2484	90.2484	0.00000
MASS (LB/HR)	23048.8	23048.8	-0.157838E-
15			
02			
ENTHALPY (BTU/HR)	-0.358808E+08	-0.358388E+08	-0.117157E-

ASPEN PLUS PLAT: WIN32 VER: 23.0 04/07/2010 PAGE
50

U-O-S BLOCK SECTION

BLOCK: P-100 MODEL: PUMP (CONTINUED)

*** INPUT DATA ***

OUTLET PRESSURE PSIA	653.000
PUMP EFFICIENCY	0.80000
DRIVER EFFICIENCY	1.00000

FLASH SPECIFICATIONS:

LIQUID PHASE CALCULATION	
NO FLASH PERFORMED	
MAXIMUM NUMBER OF ITERATIONS	30
TOLERANCE	0.000100000

*** RESULTS ***

VOLUMETRIC FLOW RATE CUFT/HR	280.408
PRESSURE CHANGE PSI	648.100
NPSH AVAILABLE FT-LBF/LB	0.0
FLUID POWER HP	13.2169
BRAKE POWER HP	16.5211
ELECTRICITY KW	12.3198
PUMP EFFICIENCY USED	0.80000
NET WORK REQUIRED HP	16.5211
HEAD DEVELOPED FT-LBF/LB	1,135.40

BLOCK: P-101 MODEL: PUMP

INLET STREAM:	S-109
OUTLET STREAM:	S-110
PROPERTY OPTION SET:	NRTL-RK RENON (NRTL) / REDLICH-KWONG

*** MASS AND ENERGY BALANCE ***

	IN	OUT	RELATIVE
DIFF.			
TOTAL BALANCE			
MOLE (LBMOL/HR)	10189.1	10189.1	0.00000
MASS (LB/HR)	978444.	978444.	0.00000
ENTHALPY (BTU/HR)	-0.380278E+10	-0.380276E+10	-0.595160E-

05

ASPEN PLUS PLAT: WIN32 VER: 23.0 04/07/2010 PAGE
51

U-O-S BLOCK SECTION

BLOCK: P-101 MODEL: PUMP (CONTINUED)

*** INPUT DATA ***

PRESSURE CHANGE	PSI	10.0000
PUMP EFFICIENCY		0.80000
DRIVER EFFICIENCY		1.00000

FLASH SPECIFICATIONS:

LIQUID PHASE CALCULATION	
NO FLASH PERFORMED	
MAXIMUM NUMBER OF ITERATIONS	30
TOLERANCE	0.000100000

*** RESULTS ***

VOLUMETRIC FLOW RATE	CUFT/HR	9,784.44
PRESSURE CHANGE	PSI	10.0000
NPSH AVAILABLE	FT-LBF/LB	0.0
FLUID POWER	HP	7.11596
BRAKE POWER	HP	8.89495
ELECTRICITY	KW	6.63296
PUMP EFFICIENCY USED		0.80000
NET WORK REQUIRED	HP	8.89495
HEAD DEVELOPED	FT-LBF/LB	14.4000

BLOCK: P-102 MODEL: PUMP

INLET STREAM:	S-113
OUTLET STREAM:	S-114
PROPERTY OPTION SET:	NRTL-RK RENON (NRTL) / REDLICH-KWONG

*** MASS AND ENERGY BALANCE ***

	IN	OUT	RELATIVE
DIFF.			
TOTAL BALANCE			
MOLE (LBMOL/HR)	227.981	227.981	0.00000
MASS (LB/HR)	39662.8	39662.8	0.00000
ENTHALPY (BTU/HR)	-0.843033E+07	-0.842921E+07	-0.133284E-

03

ASPEN PLUS PLAT: WIN32 VER: 23.0 04/07/2010 PAGE
52

U-O-S BLOCK SECTION

BLOCK: P-102 MODEL: PUMP (CONTINUED)

*** INPUT DATA ***

PRESSURE CHANGE PSI 5.00000
DRIVER EFFICIENCY 1.00000

FLASH SPECIFICATIONS:

LIQUID PHASE CALCULATION
NO FLASH PERFORMED
MAXIMUM NUMBER OF ITERATIONS 30
TOLERANCE 0.000100000

*** RESULTS ***

VOLUMETRIC FLOW RATE CUFT/HR 604.575
PRESSURE CHANGE PSI 5.00000
NPSH AVAILABLE FT-LBF/LB 0.0
FLUID POWER HP 0.21985
BRAKE POWER HP 0.44160
ELECTRICITY KW 0.32930
PUMP EFFICIENCY USED 0.49784
NET WORK REQUIRED HP 0.44160
HEAD DEVELOPED FT-LBF/LB 10.9749

BLOCK: P-103 MODEL: PUMP

INLET STREAM: S-115
OUTLET STREAM: WASTEWTR
PROPERTY OPTION SET: NRTL-RK RENON (NRTL) / REDLICH-KWONG

*** MASS AND ENERGY BALANCE ***

	IN	OUT	RELATIVE
DIFF.			
TOTAL BALANCE			
MOLE (LBMOL/HR)	456.905	456.905	0.00000
MASS (LB/HR)	8273.58	8273.58	0.00000
ENTHALPY (BTU/HR)	-0.559105E+08	-0.559101E+08	-0.756139E-

05

ASPEN PLUS PLAT: WIN32 VER: 23.0 04/07/2010 PAGE
53

U-O-S BLOCK SECTION

BLOCK: P-103 MODEL: PUMP (CONTINUED)

*** INPUT DATA ***

PRESSURE CHANGE PSI 5.00000
DRIVER EFFICIENCY 1.00000

FLASH SPECIFICATIONS:

LIQUID PHASE CALCULATION
NO FLASH PERFORMED
MAXIMUM NUMBER OF ITERATIONS 30
TOLERANCE 0.000100000

*** RESULTS ***

VOLUMETRIC FLOW RATE CUFT/HR 135.091
PRESSURE CHANGE PSI 5.00000
NPSH AVAILABLE FT-LBF/LB 0.0
FLUID POWER HP 0.049124
BRAKE POWER HP 0.16615
ELECTRICITY KW 0.12390
PUMP EFFICIENCY USED 0.29566
NET WORK REQUIRED HP 0.16615
HEAD DEVELOPED FT-LBF/LB 11.7561

BLOCK: P-104 MODEL: PUMP

INLET STREAM: S-117
OUTLET STREAM: S-118
PROPERTY OPTION SET: NRTL-RK RENON (NRTL) / REDLICH-KWONG

*** MASS AND ENERGY BALANCE ***

	IN	OUT	RELATIVE
DIFF.			
TOTAL BALANCE			
MOLE (LBMOL/HR)	9504.23	9504.23	0.00000
MASS (LB/HR)	930508.	930508.	0.00000
ENTHALPY (BTU/HR)	-0.373238E+10	-0.373101E+10	-0.367687E-

03

ASPEN PLUS PLAT: WIN32 VER: 23.0 04/07/2010 PAGE 54

U-O-S BLOCK SECTION

BLOCK: P-104 MODEL: PUMP (CONTINUED)

*** INPUT DATA ***

OUTLET PRESSURE PSIA	653.000
PUMP EFFICIENCY	0.80000
DRIVER EFFICIENCY	1.00000

FLASH SPECIFICATIONS:

LIQUID PHASE CALCULATION	
NO FLASH PERFORMED	
MAXIMUM NUMBER OF ITERATIONS	30
TOLERANCE	0.000100000

*** RESULTS ***

VOLUMETRIC FLOW RATE CUFT/HR	9,155.70
PRESSURE CHANGE PSI	648.000
NPSH AVAILABLE FT-LBF/LB	0.0
FLUID POWER HP	431.483
BRAKE POWER HP	539.354
ELECTRICITY KW	402.196
PUMP EFFICIENCY USED	0.80000
NET WORK REQUIRED HP	539.354
HEAD DEVELOPED FT-LBF/LB	918.140

BLOCK: R-100 MODEL: RSTOIC

INLET STREAMS:	TDA	O2	CO	SOLVENT
PSEUDO				
OUTLET STREAM:	S-100			
PROPERTY OPTION SET:	NRTL-RK	RENON (NRTL)	/	REDLICH-KWONG

*** MASS AND ENERGY BALANCE ***

DIFF.	IN	OUT	GENERATION	RELATIVE
TOTAL BALANCE				
MOLE (LBMOL/HR)	16145.3	15901.8	-243.518	
0.00000				
MASS (LB/HR)	0.129446E+07	0.129446E+07		-
0.179866E-15				
ENTHALPY (BTU/HR)	-0.461796E+10	-0.462414E+10		
0.133735E-02				

*** INPUT DATA ***

ASPEN PLUS PLAT: WIN32 VER: 23.0
55

04/07/2010 PAGE

U-O-S BLOCK SECTION

BLOCK: R-100 MODEL: RSTOIC (CONTINUED)
STOICHIOMETRY MATRIX:

REACTION # 1:
SUBSTREAM MIXED :
TDA -1.00 O2 -1.00 CO -2.00 WATER
2.00
TDCARB 1.00 SOLVENT -2.00

REACTION # 2:
SUBSTREAM MIXED :
TDI 1.00 TDCARB -1.00 SOLVENT 2.00

REACTION CONVERSION SPECS: NUMBER= 2
REACTION # 1:
SUBSTREAM:MIXED KEY COMP:TDA CONV FRAC: 0.8200
REACTION # 2:
SUBSTREAM:MIXED KEY COMP:TDCARB CONV FRAC: 0.7800

TWO PHASE TP FLASH
SPECIFIED TEMPERATURE F 282.765
SPECIFIED PRESSURE PSIA 652.670
MAXIMUM NO. ITERATIONS 30
CONVERGENCE TOLERANCE 0.000100000
SERIES REACTIONS
GENERATE COMBUSTION REACTIONS FOR FEED SPECIES NO

*** RESULTS ***
OUTLET TEMPERATURE F 282.76
OUTLET PRESSURE PSIA 652.67
HEAT DUTY BTU/HR -0.61841E+07
VAPOR FRACTION 0.35357

HEAT OF REACTIONS:

REACTION NUMBER	REFERENCE COMPONENT	HEAT OF REACTION BTU/LBMOL
1	TDA	-0.15077E+06
2	TDCARB	-12385.

REACTION EXTENTS:

REACTION NUMBER	REACTION EXTENT LBMOL/HR
1	193.91
2	169.11

ASPEN PLUS PLAT: WIN32 VER: 23.0 04/07/2010 PAGE 56

U-O-S BLOCK SECTION

BLOCK: R-100 MODEL: RSTOIC (CONTINUED)

V-L PHASE EQUILIBRIUM :

COMP	F(I)	X(I)	Y(I)	K(I)
TDA	0.26768E-02	0.41400E-02	0.17052E-05	
0.41187E-03				
O2	0.22079E-02	0.39502E-03	0.55224E-02	
13.980				
CO	0.24928	0.27042E-01	0.65559	
24.243				
TDI	0.14349E-01	0.22178E-01	0.34859E-04	
0.15717E-02				
WATER	0.30189E-01	0.44449E-01	0.41173E-02	
0.92628E-01				
TDCARB	0.29995E-02	0.46400E-02	0.36532E-08	
0.78731E-06				
SOLVENT	0.69830	0.89715	0.33474	
0.37311				

BLOCK: R-101 MODEL: FLASH2

 INLET STREAM: S-100
 OUTLET VAPOR STREAM: S-101
 OUTLET LIQUID STREAM: S-104
 PROPERTY OPTION SET: NRTL-RK RENON (NRTL) / REDLICH-KWONG

DIFF.	*** MASS AND ENERGY BALANCE ***	IN	OUT	RELATIVE
TOTAL BALANCE				
MOLE (LBMOL/HR)		15901.8	15901.8	0.00000
MASS (LB/HR)		0.129446E+07	0.129446E+07	0.00000
ENTHALPY (BTU/HR)		-0.462414E+10	-0.462414E+10	0.851095E-

08

*** INPUT DATA ***

TWO PHASE PQ FLASH
 PRESSURE DROP PSI 0.0
 SPECIFIED HEAT DUTY BTU/HR 0.0
 MAXIMUM NO. ITERATIONS 30
 CONVERGENCE TOLERANCE 0.000100000

*** RESULTS ***

OUTLET TEMPERATURE F 282.76
 OUTLET PRESSURE PSIA 652.67
 VAPOR FRACTION 0.35357

ASPEN PLUS PLAT: WIN32 VER: 23.0 04/07/2010 PAGE 57

U-O-S BLOCK SECTION

BLOCK: R-101 MODEL: FLASH2 (CONTINUED)

V-L PHASE EQUILIBRIUM :

COMP	F(I)	X(I)	Y(I)	K(I)
TDA	0.26768E-02	0.41400E-02	0.17052E-05	
0.41187E-03				
O2	0.22079E-02	0.39501E-03	0.55224E-02	
13.980				
CO	0.24928	0.27042E-01	0.65559	
24.243				
TDI	0.14349E-01	0.22178E-01	0.34859E-04	
0.15717E-02				
WATER	0.30189E-01	0.44449E-01	0.41174E-02	
0.92628E-01				
TDCARB	0.29995E-02	0.46400E-02	0.36533E-08	
0.78731E-06				
SOLVENT	0.69830	0.89716	0.33473	
0.37311				

BLOCK: R-102 MODEL: RSTOIC

INLET STREAMS: S-122 S-132
 OUTLET STREAM: S-123
 PROPERTY OPTION SET: NRTL-RK RENON (NRTL) / REDLICH-KWONG

DIFF.	***	MASS AND ENERGY BALANCE	***	RELATIVE
	IN	OUT	GENERATION	
TOTAL BALANCE				
MOLE (LBMOL/HR)	3673.04	3687.15	14.1137	
0.00000				
MASS (LB/HR)	309883.	309883.		-
0.187838E-15				
ENTHALPY (BTU/HR)	-0.110267E+10	-0.110063E+10		-
0.184604E-02				

*** INPUT DATA ***

STOICHIOMETRY MATRIX:

REACTION #	1:				
SUBSTREAM MIXED	:				
TDA	-1.00	O2	-1.00	CO	-2.00 WATER
2.00					
TDCARB	1.00	SOLVENT	-2.00		
REACTION #	2:				
SUBSTREAM MIXED	:				
TDI	1.00	TDCARB	-1.00	SOLVENT	2.00

```
REACTION CONVERSION SPECS: NUMBER= 2
REACTION # 1:
SUBSTREAM:MIXED KEY COMP:TDA CONV FRAC: 0.8200
REACTION # 2:
SUBSTREAM:MIXED KEY COMP:TDCARB CONV FRAC: 0.7200
```

```
TWO PHASE TP FLASH
SPECIFIED TEMPERATURE F 279.500
SPECIFIED PRESSURE PSIA 652.670
MAXIMUM NO. ITERATIONS 30
CONVERGENCE TOLERANCE 0.000100000
```

ASPEN PLUS PLAT: WIN32 VER: 23.0 04/07/2010 PAGE 58

U-O-S BLOCK SECTION

BLOCK: R-102 MODEL: RSTOIC (CONTINUED)

SERIES REACTIONS

GENERATE COMBUSTION REACTIONS FOR FEED SPECIES NO

*** RESULTS ***

OUTLET TEMPERATURE	F	279.50
OUTLET PRESSURE	PSIA	652.67
HEAT DUTY	BTU/HR	0.20356E+07
VAPOR FRACTION		0.33545

REACTION EXTENTS:

REACTION NUMBER	REACTION EXTENT LBMOL/HR
1	34.540
2	58.867

V-L PHASE EQUILIBRIUM :

COMP	F(I)	X(I)	Y(I)	K(I)
TDA 0.37863E-03	0.20563E-02	0.30937E-02	0.11714E-05	
O2 15.780	0.26850E-02	0.45068E-03	0.71113E-02	
CO 27.730	0.23890	0.23972E-01	0.66471	
TDI 0.14477E-02	0.15967E-01	0.24008E-01	0.34760E-04	
WATER 0.87693E-01	0.18737E-01	0.27000E-01	0.23677E-02	
TDCARB 0.69111E-06	0.62088E-02	0.93428E-02	0.64582E-08	
SOLVENT 0.35715	0.71544	0.91213	0.32578	

BLOCK: R-103 MODEL: FLASH2

 INLET STREAM: S-123
 OUTLET VAPOR STREAM: S-124
 OUTLET LIQUID STREAM: S-125
 PROPERTY OPTION SET: NRTL-RK RENON (NRTL) / REDLICH-KWONG

*** MASS AND ENERGY BALANCE ***
 IN OUT RELATIVE

DIFF.

ASPEN PLUS PLAT: WIN32 VER: 23.0 04/07/2010 PAGE 59

U-O-S BLOCK SECTION

BLOCK: R-103 MODEL: FLASH2 (CONTINUED)
 TOTAL BALANCE
 MOLE (LBMOL/HR) 3687.15 3687.15 -0.123333E-
 15 MASS (LB/HR) 309883. 309883. 0.00000
 ENTHALPY (BTU/HR) -0.110063E+10 -0.110063E+10 0.182364E-
 07

*** INPUT DATA ***

TWO PHASE PQ FLASH
 PRESSURE DROP PSI 0.0
 SPECIFIED HEAT DUTY BTU/HR 0.0
 MAXIMUM NO. ITERATIONS 30
 CONVERGENCE TOLERANCE 0.000100000

*** RESULTS ***

OUTLET TEMPERATURE F 279.50
 OUTLET PRESSURE PSIA 652.67
 VAPOR FRACTION 0.33544

V-L PHASE EQUILIBRIUM :

COMP	F(I)	X(I)	Y(I)	K(I)
TDA 0.37864E-03	0.20563E-02	0.30937E-02	0.11714E-05	
O2 15.781	0.26850E-02	0.45063E-03	0.71115E-02	
CO 27.731	0.23890	0.23969E-01	0.66472	
TDI 0.14477E-02	0.15967E-01	0.24008E-01	0.34758E-04	
WATER 0.87697E-01	0.18737E-01	0.27000E-01	0.23679E-02	
TDCARB 0.69111E-06	0.62088E-02	0.93427E-02	0.64570E-08	
SOLVENT 0.35714	0.71544	0.91214	0.32576	

BLOCK: SP-100 MODEL: FSPLIT

 INLET STREAM: S-103
 OUTLET STREAMS: S-120 S-127
 PROPERTY OPTION SET: NRTL-RK RENON (NRTL) / REDLICH-KWONG

*** MASS AND ENERGY BALANCE ***
 IN OUT

DIFF.

RELATIVE

	TOTAL BALANCE			
15	MOLE (LBMOL/HR)	2951.70	2951.70	0.154063E-
	MASS (LB/HR)	84460.8	84460.8	0.00000
15	ENTHALPY (BTU/HR)	-0.147130E+09	-0.147130E+09	-0.202558E-

*** INPUT DATA ***

ASPEN PLUS PLAT: WIN32 VER: 23.0 04/07/2010 PAGE
60

U-O-S BLOCK SECTION

BLOCK: SP-100 MODEL: FSPLIT (CONTINUED)

FRACTION OF FLOW STRM=S-120 FRAC= 0.30000

*** RESULTS ***

STREAM= S-120	SPLIT=	0.30000	KEY= 0	STREAM-
ORDER= 1				
S-127		0.70000	0	
2				

BLOCK: SP-101 MODEL: FSPLIT

 INLET STREAM: S-107
 OUTLET STREAMS: S-108 S-116
 PROPERTY OPTION SET: NRTL-RK RENON (NRTL) / REDLICH-KWONG

*** MASS AND ENERGY BALANCE ***

	IN	OUT	RELATIVE
DIFF.			
TOTAL BALANCE			
MOLE (LBMOL/HR)	90.2484	90.2484	0.00000
MASS (LB/HR)	23048.8	23048.8	0.157838E-
15			
ENTHALPY (BTU/HR)	-0.358388E+08	-0.358388E+08	0.00000

*** INPUT DATA ***

FRACTION OF FLOW STRM=S-108 FRAC= 0.0100000

*** RESULTS ***

STREAM= S-108	SPLIT=	0.0100000	KEY= 0	STREAM-
ORDER= 1				
S-116		0.99000	0	
2				

BLOCK: SP-102 MODEL: FSPLIT

 INLET STREAM: S-118
 OUTLET STREAMS: S-119 S-126
 PROPERTY OPTION SET: NRTL-RK RENON (NRTL) / REDLICH-KWONG

ASPEN PLUS PLAT: WIN32 VER: 23.0 04/07/2010 PAGE 61

U-O-S BLOCK SECTION

BLOCK: SP-102 MODEL: FSPLIT (CONTINUED)

*** MASS AND ENERGY BALANCE ***				
DIFF.		IN	OUT	RELATIVE
	TOTAL BALANCE			
	MOLE (LBMOL/HR)	9504.23	9504.23	0.00000
	MASS (LB/HR)	930508.	930508.	0.125109E-
15	ENTHALPY (BTU/HR)	-0.373101E+10	-0.373101E+10	0.00000

*** INPUT DATA ***

FRACTION OF FLOW STRM=S-119 FRAC= 0.28000

*** RESULTS ***

STREAM= S-119 SPLIT= 0.28000 KEY= 0 STREAM-
 ORDER= 1
 S-126 0.72000 0
 2

BLOCK: V-100 MODEL: VALVE

 INLET STREAM: S-104
 OUTLET STREAM: S-105
 PROPERTY OPTION SET: NRTL-RK RENON (NRTL) / REDLICH-KWONG

*** MASS AND ENERGY BALANCE ***				
DIFF.		IN	OUT	RELATIVE
	TOTAL BALANCE			
	MOLE (LBMOL/HR)	10279.4	10279.4	0.00000
	MASS (LB/HR)	0.100149E+07	0.100149E+07	0.00000
	ENTHALPY (BTU/HR)	-0.373429E+10	-0.373429E+10	0.00000

*** INPUT DATA ***

VALVE OUTLET PRESSURE PSIA 5.00000
 VALVE FLOW COEF CALC. NO

FLASH SPECIFICATIONS:

NPHASE 2
 MAX NUMBER OF ITERATIONS 30
 CONVERGENCE TOLERANCE 0.000100000

*** RESULTS ***

VALVE PRESSURE DROP PSI 647.670

ASPEN PLUS PLAT: WIN32 VER: 23.0
62

04/07/2010 PAGE

STREAM SECTION

```

CO O2 O2MAKEUP PSEUDLIQ PSEUDO
-----
STREAM ID          CO          O2          O2MAKEUP    PSEUDLIQ
PSEUDO
FROM :            -----
TO   :            R-100      R-100      M-102      -----      R-100

SUBSTREAM: MIXED
PHASE:           VAPOR      VAPOR      VAPOR      MIXED      MIXED
COMPONENTS: LBMOL/HR
  TDA            0.0          0.0          0.0          7.5901
7.5920
  O2              0.0          191.4530    37.0000     14.0667
37.5670
  CO             456.9050     0.0          0.0          1037.7956
3894.8980
  TDI            0.0          0.0          0.0          59.0241
59.0700
  WATER          0.0          0.0          0.0          89.3016
92.2390
  TDCARB         0.0          0.0          0.0          22.8928
22.8930
  SOLVENT        0.0          0.0          0.0          1.0733+04
1.1153+04
COMPONENTS: MOLE FRAC
  TDA            0.0          0.0          0.0          6.3441-04  4.9728-
04
  O2              0.0          1.0000     1.0000     1.1757-03  2.4606-
03
  CO             1.0000     0.0          0.0          8.6742-02
0.2551
  TDI            0.0          0.0          0.0          4.9334-03  3.8691-
03
  WATER          0.0          0.0          0.0          7.4641-03  6.0417-
03
  TDCARB         0.0          0.0          0.0          1.9135-03  1.4995-
03
  SOLVENT        0.0          0.0          0.0          0.8971
0.7305
COMPONENTS: LB/HR
  TDA            0.0          0.0          0.0          927.2855
927.5137
  O2              0.0          6126.2663  1183.9556   450.1159
1202.0989
  CO             1.2798+04   0.0          0.0          2.9069+04
1.0910+05
  TDI            0.0          0.0          0.0          1.0280+04
1.0288+04

```

Phosgene-Free Route to Toluene Diisocyanate

Bou-Saba, Dizon, Kasih, Stewart

WATER	0.0	0.0	0.0	1608.7928	
1661.7114					
TDCARB	0.0	0.0	0.0	8567.3938	
8567.4708					
SOLVENT	0.0	0.0	0.0	1.0738+06	
1.1157+06					
COMPONENTS: MASS FRAC					
TDA	0.0	0.0	0.0	8.2449-04	7.4351-
04					
O2	0.0	1.0000	1.0000	4.0022-04	9.6362-
04					
CO	1.0000	0.0	0.0	2.5847-02	8.7454-
02					
TDI	0.0	0.0	0.0	9.1400-03	8.2467-
03					
WATER	0.0	0.0	0.0	1.4304-03	1.3321-
03					
TDCARB	0.0	0.0	0.0	7.6176-03	6.8678-
03					
SOLVENT	0.0	0.0	0.0	0.9547	
0.8944					
TOTAL FLOW:					
LBMOL/HR	456.9050	191.4530	37.0000	1.1964+04	
1.5267+04					
LB/HR	1.2798+04	6126.2663	1183.9556	1.1247+06	
1.2475+06					
CUFT/HR	5337.2006	2217.5683	428.3476	2.5080+04	
6.5284+04					
STATE VARIABLES:					
TEMP F	248.0000	248.0000	248.0000	248.0000	
248.0000					
PRES PSIA	652.6698	652.6698	653.0000	639.6698	
652.6698					
VFRAC	1.0000	1.0000	1.0000	8.4609-02	
0.3091					
LFRAC	0.0	0.0	0.0	0.9154	
0.6909					
SFRAC	0.0	0.0	0.0	0.0	0.0
0.0					
ENTHALPY:					
BTU/LBMOL	-4.6396+04	1127.2831	1127.2428	-3.6015+05	-
3.0111+05					
BTU/LB	-1656.3929	35.2289	35.2277	-3831.1949	-
3685.1434					
BTU/HR	-2.1199+07	2.1582+05	4.1708+04	-4.3089+09	-
4.5971+09					

ASPEN PLUS PLAT: WIN32 VER: 23.0
63

04/07/2010 PAGE

STREAM SECTION

CO O2 O2MAKEUP PSEUDLIQ PSEUDO (CONTINUED)

STREAM ID PSEUDO	CO	O2	O2MAKEUP	PSEUDLIQ	
ENTROPY:					
BTU/LBMOL-R 91.1012	15.6175	-5.6828	-5.6838	-116.6837	-
BTU/LB-R 1.1149	0.5576	-0.1776	-0.1776	-1.2413	-
DENSITY:					
LBMOL/CUFT 0.2339	8.5608-02	8.6335-02	8.6378-02	0.4770	
LB/CUFT 19.1085	2.3979	2.7626	2.7640	44.8435	
AVG MW 81.7103	28.0104	31.9988	31.9988	94.0045	

ASPEN PLUS PLAT: WIN32 VER: 23.0
64

04/07/2010 PAGE

STREAM SECTION

```

PSEUDVAP S-100 S-101 S-102 S-103
-----

STREAM ID          PSEUDVAP   S-100     S-101     S-102     S-103
FROM :            H-104     R-100     R-101     C-100     F-100
TO   :            ----     R-101     C-100     F-100     SP-
100

SUBSTREAM: MIXED
PHASE:           VAPOR     MIXED     VAPOR     MIXED     VAPOR
COMPONENTS: LBMOL/HR
  TDA            1.4489-03  42.5657  9.5875-03  9.5875-03  4.2460-
10
  O2              23.5028   35.1097  31.0492   31.0492
21.0103
  CO             2857.1063 3963.9824 3686.0113 3686.0113
2907.0878
  TDI            4.2989-02  228.1766  0.1960    0.1960    6.1539-
07
  WATER          2.9375    480.0596 23.1497   23.1497   1.2710-
02
  TDCARB         7.9861-06  47.6967  2.0540-05 2.0540-05 2.0553-
15
  SOLVENT        419.4220  1.1104+04 1882.0240 1882.0240
23.5866
COMPONENTS: MOLE FRAC
  TDA            4.3865-07  2.6768-03 1.7052-06 1.7052-06 1.4385-
13
  O2              7.1156-03  2.2079-03 5.5224-03 5.5224-03 7.1180-
03
  CO              0.8650     0.2493    0.6556    0.6556
0.9849
  TDI            1.3015-05  1.4349-02 3.4859-05 3.4859-05 2.0849-
10
  WATER          8.8935-04  3.0189-02 4.1174-03 4.1174-03 4.3061-
06
  TDCARB         2.4178-09  2.9995-03 3.6533-09 3.6533-09 6.9630-
19
  SOLVENT        0.1270     0.6983    0.3347    0.3347    7.9909-
03
COMPONENTS: LB/HR
  TDA            0.1770    5200.2440  1.1713    1.1713    5.1873-
08
  O2              752.0626  1123.4676  993.5373  993.5373
672.3039
  CO             8.0029+04  1.1103+05 1.0325+05 1.0325+05
8.1429+04
  TDI            7.4870    3.9739+04  34.1342   34.1342   1.0718-
04

```

Phosgene-Free Route to Toluene Diisocyanate

Bou-Saba, Dizon, Kasih, Stewart

WATER	52.9207	8648.4088	417.0485	417.0485	
0.2290					
TDCARB	2.9887-03	1.7850+04	7.6870-03	7.6870-03	7.6916-
13					
SOLVENT	4.1959+04	1.1109+06	1.8828+05	1.8828+05	
2359.6160					
COMPONENTS: MASS FRAC					
TDA	1.4414-06	4.0173-03	3.9980-06	3.9980-06	6.1417-
13					
O2	6.1243-03	8.6790-04	3.3912-03	3.3912-03	7.9599-
03					
CO	0.6517	8.5775-02	0.3524	0.3524	
0.9641					
TDI	6.0969-05	3.0699-02	1.1651-04	1.1651-04	1.2689-
09					
WATER	4.3095-04	6.6811-03	1.4235-03	1.4235-03	2.7110-
06					
TDCARB	2.4338-08	1.3790-02	2.6238-08	2.6238-08	9.1067-
18					
SOLVENT	0.3417	0.8582	0.6427	0.6427	2.7937-
02					
TOTAL FLOW:					
LBMOL/HR	3303.0132	1.5902+04	5622.4398	5622.4398	
2951.6974					
LB/HR	1.2280+05	1.2945+06	2.9297+05	2.9297+05	
8.4461+04					
CUFT/HR	3.8352+04	7.6529+04	6.3130+04	2.9754+04	
2.7073+04					
STATE VARIABLES:					
TEMP F	248.0000	282.7646	282.7646	100.0000	
99.9092					
PRES PSIA	639.6698	652.6698	652.6698	647.6698	
644.6698					
VFRAC	1.0000	0.3536	1.0000	0.5248	
1.0000					
LFRAC	0.0	0.6464	0.0	0.4752	0.0
SFRAC	0.0	0.0	0.0	0.0	0.0
ENTHALPY:					
BTU/LBMOL	-8.8704+04	-2.9079+05	-1.5827+05	-1.6708+05	-
4.9846+04					
BTU/LB	-2385.9149	-3572.2443	-3037.3316	-3206.4374	-
1741.9918					
BTU/HR	-2.9299+08	-4.6241+09	-8.8985+08	-9.3939+08	-
1.4713+08					

ASPEN PLUS PLAT: WIN32 VER: 23.0
65

04/07/2010 PAGE

STREAM SECTION

PSEUDVAP S-100 S-101 S-102 S-103 (CONTINUED)

STREAM ID	PSEUDVAP	S-100	S-101	S-102	S-103
ENTROPY:					
BTU/LBMOL-R		-0.4432	-86.2780	-26.8791	-40.1237
12.8541					
BTU/LB-R		-1.1922-02	-1.0599	-0.5158	-0.7700
0.4492					
DENSITY:					
LBMOL/CUFT		8.6125-02	0.2078	8.9061-02	0.1890
0.1090					
LB/CUFT		3.2020	16.9147	4.6407	9.8465
3.1198					
AVG MW		37.1783	81.4036	52.1075	52.1075
28.6143					

ASPEN PLUS PLAT: WIN32 VER: 23.0
66

04/07/2010 PAGE

STREAM SECTION

	S-104	S-105	S-106	S-107	S-108
STREAM ID	S-104	S-105	S-106	S-107	S-108
FROM :	R-101	V-100	D-100	P-100	SP-
101					
TO :	V-100	D-100	P-100	SP-101	C-101
SUBSTREAM: MIXED					
PHASE:	LIQUID	MIXED	LIQUID	LIQUID	
LIQUID					
COMPONENTS: LBMOL/HR					
TDA	42.5561	42.5561	42.5477	42.5477	
0.4255					
O2	4.0605	4.0605	0.0	0.0	0.0
CO	277.9710	277.9710	0.0	0.0	0.0
TDI	227.9806	227.9806	4.0319-03	4.0319-03	4.0319-
05					
WATER	456.9099	456.9099	1.2620-23	1.2620-23	1.2620-
25					
TDCARB	47.6967	47.6967	47.6967	47.6967	
0.4770					
SOLVENT	9222.1896	9222.1896	7.8168-20	7.8168-20	7.8168-
22					
COMPONENTS: MOLE FRAC					
TDA	4.1400-03	4.1400-03	0.4715	0.4715	
0.4715					
O2	3.9501-04	3.9501-04	0.0	0.0	0.0
CO	2.7042-02	2.7042-02	0.0	0.0	0.0
TDI	2.2178-02	2.2178-02	4.4676-05	4.4676-05	4.4676-
05					
WATER	4.4449-02	4.4449-02	1.3984-25	1.3984-25	1.3984-
25					
TDCARB	4.6400-03	4.6400-03	0.5285	0.5285	
0.5285					
SOLVENT	0.8972	0.8972	8.6615-22	8.6615-22	8.6615-
22					
COMPONENTS: LB/HR					
TDA	5199.0727	5199.0727	5198.0427	5198.0427	
51.9804					
O2	129.9303	129.9303	0.0	0.0	0.0
CO	7786.0794	7786.0794	0.0	0.0	0.0
TDI	3.9705+04	3.9705+04	0.7022	0.7022	7.0220-
03					
WATER	8231.3604	8231.3604	2.2736-22	2.2736-22	2.2736-
24					
TDCARB	1.7850+04	1.7850+04	1.7850+04	1.7850+04	
178.5001					

Phosgene-Free Route to Toluene Diisocyanate

Bou-Saba, Dizon, Kasih, Stewart

SOLVENT	9.2259+05	9.2259+05	7.8200-18	7.8200-18	7.8200-
20					
COMPONENTS: MASS FRAC					
TDA	5.1913-03	5.1913-03	0.2255	0.2255	
0.2255					
O2	1.2974-04	1.2974-04	0.0	0.0	0.0
CO	7.7745-03	7.7745-03	0.0	0.0	0.0
TDI	3.9646-02	3.9646-02	3.0466-05	3.0466-05	3.0466-
05					
WATER	8.2191-03	8.2191-03	9.8643-27	9.8643-27	9.8643-
27					
TDCARB	1.7823-02	1.7823-02	0.7744	0.7744	
0.7744					
SOLVENT	0.9212	0.9212	3.3928-22	3.3928-22	3.3928-
22					
TOTAL FLOW:					
LBMOL/HR	1.0279+04	1.0279+04	90.2484	90.2484	
0.9025					
LB/HR	1.0015+06	1.0015+06	2.3049+04	2.3049+04	
230.4875					
CUFT/HR	1.3399+04	6.3259+06	280.4083	280.9195	
2.8092					
STATE VARIABLES:					
TEMP F	282.7646	96.7787	517.8417	521.1076	
521.1076					
PRES PSIA	652.6698	5.0000	4.9000	653.0000	
653.0000					
VFRAC	0.0	0.5187	0.0	0.0	0.0
LFRAC	1.0000	0.4813	1.0000	1.0000	
1.0000					
SFRAC	0.0	0.0	0.0	0.0	0.0
ENTHALPY:					
BTU/LBMOL	-3.6328+05	-3.6328+05	-3.9758+05	-3.9711+05	-
3.9711+05					
BTU/LB	-3728.7247	-3728.7247	-1556.7352	-1554.9114	-
1554.9114					
BTU/HR	-3.7343+09	-3.7343+09	-3.5881+07	-3.5839+07	-
3.5839+05					

ASPEN PLUS PLAT: WIN32 VER: 23.0
67

04/07/2010 PAGE

STREAM SECTION

S-104 S-105 S-106 S-107 S-108 (CONTINUED)

STREAM ID	S-104	S-105	S-106	S-107	S-108
ENTROPY:					
BTU/LBMOL-R	-118.7670	-116.0471	-187.3015	-187.1685	-
187.1685					
BTU/LB-R	-1.2190	-1.1911	-0.7334	-0.7329	-
0.7329					
DENSITY:					
LBMOL/CUFT	0.7672	1.6250-03	0.3218	0.3213	
0.3213					
LB/CUFT	74.7457	0.1583	82.1971	82.0475	
82.0475					
AVG MW	97.4275	97.4275	255.3923	255.3923	
255.3923					

ASPEN PLUS PLAT: WIN32 VER: 23.0
68

04/07/2010 PAGE

STREAM SECTION

S-109	S-110	S-111	S-112	S-113	

STREAM ID	S-109	S-110	S-111	S-112	S-113
FROM :	D-100	P-101	H-100	D-101	D-102
TO :	P-101	H-100	D-101	D-102	P-102
SUBSTREAM: MIXED					
PHASE:	LIQUID	LIQUID	MIXED	LIQUID	
LIQUID					
COMPONENTS: LBMOL/HR					
TDA	8.4308-03	8.4308-03	8.4308-03	8.4308-03	8.4302-03
O2	4.0605	4.0605	4.0605	2.5561-27	0.0
CO	277.9710	277.9710	277.9710	3.7754-28	0.0
TDI	227.9766	227.9766	227.9766	227.9766	
227.7057					
WATER	456.9099	456.9099	456.9099	456.9009	
0.2669					
TDCARB	9.7456-33	9.7456-33	9.7456-33	0.0	0.0
SOLVENT	9222.1896	9222.1896	9222.1896	9.7737-05	6.5654-14
COMPONENTS: MOLE FRAC					
TDA	8.2744-07	8.2744-07	8.2744-07	1.2310-05	3.6978-05
O2	3.9851-04	3.9851-04	3.9851-04	3.7321-30	0.0
CO	2.7281-02	2.7281-02	2.7281-02	5.5124-31	0.0
TDI	2.2375-02	2.2375-02	2.2375-02	0.3329	
0.9988					
WATER	4.4843-02	4.4843-02	4.4843-02	0.6671	1.1707-03
TDCARB	0.0	0.0	0.0	0.0	0.0
SOLVENT	0.9051	0.9051	0.9051	1.4271-07	2.8798-16
COMPONENTS: LB/HR					
TDA	1.0300	1.0300	1.0300	1.0300	
1.0299					
O2	129.9303	129.9303	129.9303	8.1792-26	0.0
CO	7786.0794	7786.0794	7786.0794	1.0575-26	0.0
TDI	3.9704+04	3.9704+04	3.9704+04	3.9704+04	
3.9657+04					
WATER	8231.3604	8231.3604	8231.3604	8231.1978	
4.8083					
TDCARB	3.6472-30	3.6472-30	3.6472-30	0.0	0.0
SOLVENT	9.2259+05	9.2259+05	9.2259+05	9.7777-03	6.5681-12
COMPONENTS: MASS FRAC					
TDA	1.0527-06	1.0527-06	1.0527-06	2.1487-05	2.5967-05

Phosgene-Free Route to Toluene Diisocyanate

Bou-Saba, Dizon, Kasih, Stewart

O2	1.3279-04	1.3279-04	1.3279-04	1.7063-30	0.0
CO	7.9576-03	7.9576-03	7.9576-03	2.2060-31	0.0
TDI	4.0579-02	4.0579-02	4.0579-02	0.8283	
0.9999					
WATER	8.4127-03	8.4127-03	8.4127-03	0.1717	1.2123-
04					
TDCARB	0.0	0.0	0.0	0.0	0.0
SOLVENT	0.9429	0.9429	0.9429	2.0397-07	1.6560-
16					
TOTAL FLOW:					
LBMOL/HR	1.0189+04	1.0189+04	1.0189+04	684.8860	
227.9810					
LB/HR	9.7844+05	9.7844+05	9.7844+05	4.7936+04	
3.9663+04					
CUFT/HR	9784.4437	9784.7549	7.9572+06	709.8577	
604.5752					
STATE VARIABLES:					
TEMP F	34.9811	35.0177	120.0000	200.7140	
352.2005					
PRES PSIA	2.0000	12.0000	7.0000	7.8000	
2.0077					
VFRAC	0.0	0.0	0.8870	0.0	0.0
LFRAC	1.0000	1.0000	0.1130	1.0000	
1.0000					
SFRAC	0.0	0.0	0.0	0.0	0.0
ENTHALPY:					
BTU/LBMOL	-3.7322+05	-3.7322+05	-3.5620+05	-9.6220+04	-
3.6978+04					
BTU/LB	-3886.5552	-3886.5321	-3709.3534	-1374.7336	-
212.5500					
BTU/HR	-3.8028+09	-3.8028+09	-3.6294+09	-6.5900+07	-
8.4303+06					

ASPEN PLUS PLAT: WIN32 VER: 23.0
69

04/07/2010 PAGE

STREAM SECTION

S-109 S-110 S-111 S-112 S-113 (CONTINUED)

STREAM ID	S-109	S-110	S-111	S-112	S-113
ENTROPY:					
BTU/LBMOL-R	-134.5877	-134.5868	-104.1612	-44.7538	-
53.4247					
BTU/LB-R	-1.4015	-1.4015	-1.0847	-0.6394	-
0.3071					
DENSITY:					
LBMOL/CUFT	1.0414	1.0413	1.2805-03	0.9648	
0.3771					
LB/CUFT	100.0000	99.9968	0.1230	67.5296	
65.6044					
AVG MW	96.0284	96.0284	96.0284	69.9918	
173.9742					

ASPEN PLUS PLAT: WIN32 VER: 23.0
70

04/07/2010 PAGE

STREAM SECTION

S-114	S-115	S-116	S-117	S-118	

STREAM ID	S-114	S-115	S-116	S-117	S-118
FROM :	P-102	D-102	SP-101	D-101	P-104
TO :	C-102	P-103	M-100	P-104	SP-
102					
SUBSTREAM: MIXED					
PHASE:	LIQUID	LIQUID	LIQUID	LIQUID	
LIQUID					
COMPONENTS: LBMOL/HR					
TDA	8.4302-03	6.4653-07	42.1222	0.0	0.0
O2	0.0	0.0	0.0	4.0605	
4.0605					
CO	0.0	0.0	0.0	277.9710	
277.9710					
TDI	227.7057	0.2709	3.9916-03	8.3292-33	8.3292-
33					
WATER	0.2669	456.6340	1.2494-23	9.0236-03	9.0236-
03					
TDCARB	0.0	0.0	47.2197	0.0	0.0
SOLVENT	6.5654-14	9.7737-05	7.7387-20	9222.1895	
9222.1895					
COMPONENTS: MOLE FRAC					
TDA	3.6978-05	1.4150-09	0.4715	0.0	0.0
O2	0.0	0.0	0.0	4.2723-04	4.2723-
04					
CO	0.0	0.0	0.0	2.9247-02	2.9247-
02					
TDI	0.9988	5.9289-04	4.4676-05	0.0	0.0
WATER	1.1707-03	0.9994	1.3984-25	9.4943-07	9.4943-
07					
TDCARB	0.0	0.0	0.5285	0.0	0.0
SOLVENT	2.8798-16	2.1391-07	8.6615-22	0.9703	
0.9703					
COMPONENTS: LB/HR					
TDA	1.0299	7.8987-05	5146.0623	0.0	0.0
O2	0.0	0.0	0.0	129.9303	
129.9303					
CO	0.0	0.0	0.0	7786.0794	
7786.0794					
TDI	3.9657+04	47.1788	0.6952	1.4506-30	1.4506-
30					
WATER	4.8083	8226.3895	2.2509-22	0.1626	
0.1626					
TDCARB	0.0	0.0	1.7672+04	0.0	0.0
SOLVENT	6.5681-12	9.7777-03	7.7418-18	9.2259+05	
9.2259+05					

Phosgene-Free Route to Toluene Diisocyanate

Bou-Saba, Dizon, Kasih, Stewart

COMPONENTS: MASS FRAC						
TDA	2.5967-05	9.5469-09	0.2255	0.0	0.0	
O2	0.0	0.0	0.0	1.3963-04	1.3963-	
04						
CO	0.0	0.0	0.0	8.3676-03	8.3676-	
03						
TDI	0.9999	5.7023-03	3.0466-05	0.0	0.0	
WATER	1.2123-04	0.9943	9.8643-27	1.7470-07	1.7470-	
07						
TDCARB	0.0	0.0	0.7744	0.0	0.0	
SOLVENT	1.6560-16	1.1818-06	3.3928-22	0.9915		
0.9915						
TOTAL FLOW:						
LBMOL/HR	227.9810	456.9050	89.3459	9504.2300		
9504.2300						
LB/HR	3.9663+04	8273.5781	2.2818+04	9.3051+05		
9.3051+05						
CUFT/HR	604.5941	135.0907	278.1103	9155.6965		
9176.0148						
STATE VARIABLES:						
TEMP F	352.2510	101.7049	521.1076	34.0916		
36.5130						
PRES PSIA	7.0077	1.0000	653.0000	5.0000		
653.0000						
VFRAC	0.0	0.0	0.0	0.0	0.0	
LFRAC	1.0000	1.0000	1.0000	1.0000		
1.0000						
SFRAC	0.0	0.0	0.0	0.0	0.0	
0.0						
ENTHALPY:						
BTU/LBMOL	-3.6973+04	-1.2237+05	-3.9711+05	-3.9271+05	-	
3.9256+05						
BTU/LB	-212.5217	-6757.7138	-1554.9114	-4011.1232	-	
4009.6484						
BTU/HR	-8.4292+06	-5.5910+07	-3.5480+07	-3.7324+09	-	
3.7310+09						

ASPEN PLUS PLAT: WIN32 VER: 23.0
71

04/07/2010 PAGE

STREAM SECTION

S-114 S-115 S-116 S-117 S-118 (CONTINUED)

STREAM ID	S-114	S-115	S-116	S-117	S-118
ENTROPY:					
BTU/LBMOL-R	-53.4217	-38.1227	-187.1685	-140.8660	-
140.8045					
BTU/LB-R	-0.3071	-2.1053	-0.7329	-1.4388	-
1.4382					
DENSITY:					
LBMOL/CUFT	0.3771	3.3822	0.3213	1.0381	
1.0358					
LB/CUFT	65.6024	61.2446	82.0475	101.6316	
101.4065					
AVG MW	173.9742	18.1079	255.3923	97.9046	
97.9046					

ASPEN PLUS PLAT: WIN32 VER: 23.0
72

04/07/2010 PAGE

STREAM SECTION

	S-119	S-120	S-121	S-122	S-123
STREAM ID	S-119	S-120	S-121	S-122	S-123
FROM :	SP-102	SP-100	M-100	H-101	R-102
TO :	M-100	M-102	H-101	R-102	R-103
SUBSTREAM: MIXED					
PHASE:	LIQUID	VAPOR	LIQUID	LIQUID	MIXED
COMPONENTS: LBMOL/HR					
TDA	0.0	1.2738-10	42.1222	42.1222	
7.5820					
O2	1.1369	6.3031	1.1369	1.1369	
9.8998					
CO	77.8319	872.1263	77.8319	77.8319	
880.8778					
TDI	2.3322-33	1.8462-07	3.9916-03	3.9916-03	
58.8711					
WATER	2.5266-03	3.8130-03	2.5266-03	2.5266-03	
69.0867					
TDCARB	0.0	6.1658-16	47.2197	47.2197	
22.8928					
SOLVENT	2582.2131	7.0760	2582.2131	2582.2131	
2637.9430					
COMPONENTS: MOLE FRAC					
TDA	0.0	1.4385-13	1.5314-02	1.5314-02	2.0563-
03					
O2	4.2723-04	7.1180-03	4.1335-04	4.1335-04	2.6850-
03					
CO	2.9247-02	0.9849	2.8297-02	2.8297-02	
0.2389					
TDI	0.0	2.0849-10	1.4512-06	1.4512-06	1.5967-
02					
WATER	9.4943-07	4.3061-06	9.1859-07	9.1859-07	1.8737-
02					
TDCARB	0.0	6.9630-19	1.7168-02	1.7168-02	6.2088-
03					
SOLVENT	0.9703	7.9909-03	0.9388	0.9388	
0.7154					
COMPONENTS: LB/HR					
TDA	0.0	1.5562-08	5146.0623	5146.0623	
926.2912					
O2	36.3805	201.6912	36.3805	36.3805	
316.7826					
CO	2180.1022	2.4429+04	2180.1022	2180.1022	
2.4674+04					
TDI	4.0617-31	3.2153-05	0.6952	0.6952	
1.0253+04					

Phosgene-Free Route to Toluene Diisocyanate

Bou-Saba, Dizon, Kasih, Stewart

WATER	4.5518-02	6.8693-02	4.5518-02	4.5518-02	
1244.6167					
TDCARB	0.0	2.3075-13	1.7672+04	1.7672+04	
8567.3891					
SOLVENT	2.5833+05	707.8848	2.5833+05	2.5833+05	
2.6390+05					
COMPONENTS: MASS FRAC					
TDA	0.0	6.1417-13	1.8161-02	1.8161-02	2.9892-
03					
O2	1.3963-04	7.9599-03	1.2839-04	1.2839-04	1.0223-
03					
CO	8.3676-03	0.9641	7.6937-03	7.6937-03	7.9623-
02					
TDI	0.0	1.2689-09	2.4533-06	2.4533-06	3.3087-
02					
WATER	1.7470-07	2.7110-06	1.6064-07	1.6064-07	4.0164-
03					
TDCARB	0.0	9.1067-18	6.2364-02	6.2364-02	2.7647-
02					
SOLVENT	0.9915	2.7937-02	0.9117	0.9117	
0.8516					
TOTAL FLOW:					
LBMOL/HR	2661.1844	885.5092	2750.5303	2750.5303	
3687.1533					
LB/HR	2.6054+05	2.5338+04	2.8336+05	2.8336+05	
3.0988+05					
CUFT/HR	2569.2842	8121.7701	2901.2637	3511.3056	
1.7095+04					
STATE VARIABLES:					
TEMP F	36.5130	99.9092	74.9579	248.0000	
279.5000					
PRES PSIA	653.0000	644.6698	653.0000	648.0000	
652.6698					
VFRAC	0.0	1.0000	0.0	0.0	
0.3354					
LFRAC	1.0000	0.0	1.0000	1.0000	
0.6646					
SFRAC	0.0	0.0	0.0	0.0	0.0
ENTHALPY:					
BTU/LBMOL	-3.9256+05	-4.9846+04	-3.9271+05	-3.8522+05	-
2.9851+05					
BTU/LB	-4009.6484	-1741.9918	-3811.9749	-3739.2476	-
3551.7763					
BTU/HR	-1.0447+09	-4.4139+07	-1.0802+09	-1.0596+09	-
1.1006+09					

ASPEN PLUS PLAT: WIN32 VER: 23.0
73

04/07/2010 PAGE

STREAM SECTION

S-119 S-120 S-121 S-122 S-123 (CONTINUED)

STREAM ID	S-119	S-120	S-121	S-122	S-123
ENTROPY:					
BTU/LBMOL-R	-140.8045	12.8541	-141.0933	-129.1905	-
89.5060					
BTU/LB-R	-1.4382	0.4492	-1.3696	-1.2540	-
1.0650					
DENSITY:					
LBMOL/CUFT	1.0358	0.1090	0.9480	0.7833	
0.2157					
LB/CUFT	101.4065	3.1198	97.6679	80.6995	
18.1269					
AVG MW	97.9046	28.6143	103.0203	103.0203	
84.0439					

ASPEN PLUS PLAT: WIN32 VER: 23.0
74

04/07/2010 PAGE

STREAM SECTION

S-124	S-125	S-126	S-127	S-128	

STREAM ID	S-124	S-125	S-126	S-127	S-128
FROM :	R-103	R-103	SP-102	SP-100	F-100
TO :	M-103	M-101	M-101	M-103	M-101
SUBSTREAM: MIXED					
PHASE:	VAPOR	LIQUID	LIQUID	VAPOR	
LIQUID					
COMPONENTS: LBMOL/HR					
TDA	1.4489-03	7.5805	0.0	2.9722-10	9.5875-
03					
O2	8.7956	1.1042	2.9235	14.7072	
10.0389					
CO	822.1449	58.7330	200.1391	2034.9615	
778.9235					
TDI	4.2989-02	58.8282	5.9970-33	4.3078-07	
0.1960					
WATER	2.9286	66.1581	6.4970-03	8.8971-03	
23.1370					
TDCARB	7.9861-06	22.8928	0.0	1.4387-15	2.0540-
05					
SOLVENT	402.9114	2235.0316	6639.9764	16.5106	
1858.4373					
COMPONENTS: MOLE FRAC					
TDA	1.1714-06	3.0937-03	0.0	1.4385-13	3.5898-
06					
O2	7.1115-03	4.5063-04	4.2723-04	7.1180-03	3.7589-
03					
CO	0.6647	2.3969-02	2.9247-02	0.9849	
0.2917					
TDI	3.4758-05	2.4008-02	0.0	2.0849-10	7.3386-
05					
WATER	2.3679-03	2.7000-02	9.4943-07	4.3061-06	8.6631-
03					
TDCARB	6.4570-09	9.3427-03	0.0	6.9630-19	7.6908-
09					
SOLVENT	0.3258	0.9121	0.9703	7.9909-03	
0.6959					
COMPONENTS: LB/HR					
TDA	0.1770	926.1142	0.0	3.6311-08	
1.1713					
O2	281.4499	35.3327	93.5498	470.6127	
321.2334					
CO	2.3029+04	1645.1336	5605.9771	5.7000+04	
2.1818+04					
TDI	7.4869	1.0245+04	1.0444-30	7.5023-05	
34.1341					

Phosgene-Free Route to Toluene Diisocyanate

Bou-Saba, Dizon, Kasih, Stewart

WATER	52.7604	1191.8562	0.1170	0.1603	
416.8195					
TDCARB	2.9887-03	8567.3861	0.0	5.3841-13	7.6870-
03					
SOLVENT	4.0307+04	2.2359+05	6.6427+05	1651.7312	
1.8592+05					
COMPONENTS: MASS FRAC					
TDA	2.7798-06	3.7616-03	0.0	6.1417-13	5.6175-
06					
O2	4.4199-03	1.4351-04	1.3963-04	7.9599-03	1.5406-
03					
CO	0.3616	6.6820-03	8.3676-03	0.9641	
0.1046					
TDI	1.1757-04	4.1614-02	0.0	1.2689-09	1.6370-
04					
WATER	8.2855-04	4.8409-03	1.7470-07	2.7110-06	1.9990-
03					
TDCARB	4.6935-08	3.4798-02	0.0	9.1067-18	3.6866-
08					
SOLVENT	0.6330	0.9082	0.9915	2.7937-02	
0.8917					
TOTAL FLOW:					
LBMOL/HR	1236.8250	2450.3283	6843.0456	2066.1882	
2670.7424					
LB/HR	6.3678+04	2.4620+05	6.6997+05	5.9123+04	
2.0851+05					
CUFT/HR	1.3866+04	3228.6247	6606.7309	1.8951+04	
2811.6950					
STATE VARIABLES:					
TEMP F	279.5008	279.5008	36.5130	99.9092	
99.9092					
PRES PSIA	652.6698	652.6698	653.0000	644.6698	
644.6698					
VFRAC	1.0000	0.0	0.0	1.0000	0.0
LFRAC	0.0	1.0000	1.0000	0.0	
1.0000					
SFRAC	0.0	0.0	0.0	0.0	0.0
ENTHALPY:					
BTU/LBMOL	-1.5513+05	-3.7088+05	-3.9256+05	-4.9846+04	-
2.9665+05					
BTU/LB	-3013.0852	-3691.1024	-4009.6484	-1741.9918	-
3799.6378					
BTU/HR	-1.9187+08	-9.0877+08	-2.6863+09	-1.0299+08	-
7.9226+08					

ASPEN PLUS PLAT: WIN32 VER: 23.0
75

04/07/2010 PAGE

STREAM SECTION

S-124 S-125 S-126 S-127 S-128 (CONTINUED)

STREAM ID	S-124	S-125	S-126	S-127	S-128
ENTROPY:					
BTU/LBMOL-R	-25.7536	-121.6856	-140.8045	12.8541	-
98.6633					
BTU/LB-R	-0.5002	-1.2111	-1.4382	0.4492	-
1.2637					
DENSITY:					
LBMOL/CUFT	8.9195-02	0.7589	1.0358	0.1090	
0.9499					
LB/CUFT	4.5922	76.2569	101.4065	3.1198	
74.1582					
AVG MW	51.4850	100.4783	97.9046	28.6143	
78.0720					

ASPEN PLUS PLAT: WIN32 VER: 23.0
76

04/07/2010 PAGE

STREAM SECTION

S-129 S-130 S-131 S-132 SLUDGE

STREAM ID	S-129	S-130	S-131	S-132	
SLUDGE					
FROM :	M-101	M-103	M-102	H-103	C-101
TO :	H-102	H-104	H-103	R-102	----
SUBSTREAM: MIXED					
PHASE:	LIQUID	MIXED	VAPOR	VAPOR	
LIQUID					
COMPONENTS: LBMOL/HR					
TDA	7.5901	1.4489-03	1.2738-10	1.2738-10	
0.4255					
O2	14.0667	23.5028	43.3031	43.3031	0.0
CO	1037.7956	2857.1063	872.1263	872.1263	0.0
TDI	59.0241	4.2989-02	1.8462-07	1.8462-07	4.0319-
05					
WATER	89.3016	2.9375	3.8130-03	3.8130-03	1.2620-
25					
TDCARB	22.8928	7.9861-06	6.1658-16	6.1658-16	
0.4770					
SOLVENT	1.0733+04	419.4220	7.0760	7.0760	7.8168-
22					
COMPONENTS: MOLE FRAC					
TDA	6.3441-04	4.3865-07	1.3808-13	1.3808-13	
0.4715					
O2	1.1757-03	7.1156-03	4.6941-02	4.6941-02	0.0
CO	8.6742-02	0.8650	0.9454	0.9454	0.0
TDI	4.9334-03	1.3015-05	2.0013-10	2.0013-10	4.4676-
05					
WATER	7.4641-03	8.8935-04	4.1333-06	4.1333-06	1.3984-
25					
TDCARB	1.9135-03	2.4178-09	6.6837-19	6.6837-19	
0.5285					
SOLVENT	0.8971	0.1270	7.6704-03	7.6704-03	8.6615-
22					
COMPONENTS: LB/HR					
TDA	927.2855	0.1770	1.5562-08	1.5562-08	
51.9804					
O2	450.1159	752.0626	1385.6468	1385.6468	0.0
CO	2.9069+04	8.0029+04	2.4429+04	2.4429+04	0.0
TDI	1.0280+04	7.4870	3.2153-05	3.2153-05	7.0220-
03					
WATER	1608.7928	52.9207	6.8693-02	6.8693-02	2.2736-
24					
TDCARB	8567.3938	2.9887-03	2.3075-13	2.3075-13	
178.5001					

Phosgene-Free Route to Toluene Diisocyanate

Bou-Saba, Dizon, Kasih, Stewart

20	SOLVENT	1.0738+06	4.1959+04	707.8848	707.8848	7.8200-
	COMPONENTS: MASS FRAC					
	TDA	8.2449-04	1.4414-06	5.8675-13	5.8675-13	
0.2255	O2	4.0022-04	6.1243-03	5.2245-02	5.2245-02	0.0
	CO	2.5847-02	0.6517	0.9211	0.9211	0.0
	TDI	9.1400-03	6.0969-05	1.2123-09	1.2123-09	3.0466-
05	WATER	1.4304-03	4.3095-04	2.5900-06	2.5900-06	9.8643-
27	TDCARB	7.6176-03	2.4338-08	8.7002-18	8.7002-18	
0.7744	SOLVENT	0.9547	0.3417	2.6690-02	2.6690-02	3.3928-
22	TOTAL FLOW:					
	LBMOL/HR	1.1964+04	3303.0132	922.5092	922.5092	
0.9025	LB/HR	1.1247+06	1.2280+05	2.6522+04	2.6522+04	
230.4875	CUFT/HR	1.2669+04	3.5336+04	8556.0116	1.0976+04	
2.3532	STATE VARIABLES:					
	TEMP F	118.7007	208.6551	105.7438	248.0000	
140.0000	PRES PSIA	644.6698	644.6698	644.6698	639.6698	
648.0000	VFRAC	0.0	0.9867	1.0000	1.0000	0.0
	LFRAC	1.0000	1.3279-02	0.0	0.0	
1.0000	SFRAC	0.0	0.0	0.0	0.0	0.0
	ENTHALPY:					
	BTU/LBMOL	-3.6671+05	-8.9269+04	-4.7801+04	-4.6736+04	-
4.2798+05	BTU/LB	-3900.9803	-2401.1142	-1662.6564	-1625.6031	-
1675.7704	BTU/HR	-4.3874+09	-2.9486+08	-4.4097+07	-4.3115+07	-
3.8624+05						

ASPEN PLUS PLAT: WIN32 VER: 23.0
77

04/07/2010 PAGE

STREAM SECTION

S-129 S-130 S-131 S-132 SLUDGE (CONTINUED)

STREAM ID	S-129	S-130	S-131	S-132	
SLUDGE					
ENTROPY:					
BTU/LBMOL-R	-126.6648	-1.2859	12.4156	14.1122	-
224.3002					
BTU/LB-R	-1.3474	-3.4586-02	0.4318	0.4909	-
0.8783					
DENSITY:					
LBMOL/CUFT	0.9443	9.3475-02	0.1078	8.4047-02	
0.3835					
LB/CUFT	88.7711	3.4753	3.0998	2.4164	
97.9454					
AVG MW	94.0045	37.1783	28.7501	28.7501	
255.3923					

ASPEN PLUS PLAT: WIN32 VER: 23.0
78

04/07/2010 PAGE

STREAM SECTION

SOLVENT TDA TDI WASTEWTR

STREAM ID	SOLVENT	TDA	TDI	WASTEWTR
FROM :	----	----	C-102	P-103
TO :	R-100	R-100	----	----

SUBSTREAM: MIXED

PHASE:	LIQUID	LIQUID	LIQUID	LIQUID
COMPONENTS: LBMOL/HR				
TDA	0.0	228.8840	8.4302-03	6.4653-07
O2	0.0	0.0	0.0	0.0
CO	0.0	0.0	0.0	0.0
TDI	0.0	0.0	227.7057	0.2709
WATER	0.0	0.0	0.2669	456.6340
TDCARB	0.0	0.0	0.0	0.0
SOLVENT	0.9530	0.0	6.5654-14	9.7737-05

COMPONENTS: MOLE FRAC

TDA	0.0	1.0000	3.6978-05	1.4150-09
O2	0.0	0.0	0.0	0.0
CO	0.0	0.0	0.0	0.0
TDI	0.0	0.0	0.9988	5.9289-04
WATER	0.0	0.0	1.1707-03	0.9994
TDCARB	0.0	0.0	0.0	0.0
SOLVENT	1.0000	0.0	2.8798-16	2.1391-07

COMPONENTS: LB/HR

TDA	0.0	2.7963+04	1.0299	7.8987-05
O2	0.0	0.0	0.0	0.0
CO	0.0	0.0	0.0	0.0
TDI	0.0	0.0	3.9657+04	47.1788
WATER	0.0	0.0	4.8083	8226.3895
TDCARB	0.0	0.0	0.0	0.0
SOLVENT	95.3385	0.0	6.5681-12	9.7777-03

COMPONENTS: MASS FRAC

TDA	0.0	1.0000	2.5967-05	9.5469-09
O2	0.0	0.0	0.0	0.0
CO	0.0	0.0	0.0	0.0
TDI	0.0	0.0	0.9999	5.7023-03
WATER	0.0	0.0	1.2123-04	0.9943
TDCARB	0.0	0.0	0.0	0.0
SOLVENT	1.0000	0.0	1.6560-16	1.1818-06

TOTAL FLOW:

LBMOL/HR	0.9530	228.8840	227.9810	456.9050
LB/HR	95.3385	2.7963+04	3.9663+04	8273.5781
CUFT/HR	1.1828	434.6271	538.8068	135.0938

STATE VARIABLES:

TEMP F	248.0000	248.0000	140.0000	101.7455
PRES PSIA	652.6698	652.6698	2.0077	6.0000
VFRAC	0.0	0.0	0.0	0.0

Phosgene-Free Route to Toluene Diisocyanate

Bou-Saba, Dizon, Kasih, Stewart

LFRAC	1.0000	1.0000	1.0000	1.0000
SFRAC	0.0	0.0	0.0	0.0
ENTHALPY:				
BTU/LBMOL	-3.9398+05	2399.5664	-5.0984+04	-1.2237+05
BTU/LB	-3938.2172	19.6412	-293.0522	-6757.6627
BTU/HR	-3.7546+05	5.4922+05	-1.1623+07	-5.5910+07

ASPEN PLUS PLAT: WIN32 VER: 23.0
79

04/07/2010 PAGE

STREAM SECTION

SOLVENT TDA TDI WASTEWTR (CONTINUED)

STREAM ID	SOLVENT	TDA	TDI	WASTEWTR
ENTROPY:				
BTU/LBMOL-R	-130.4803	-135.4934	-73.2656	-38.1216
BTU/LB-R	-1.3043	-1.1091	-0.4211	-2.1052
DENSITY:				
LBMOL/CUFT	0.8057	0.5266	0.4231	3.3821
LB/CUFT	80.6007	64.3373	73.6123	61.2432
AVG MW	100.0404	122.1699	173.9742	18.1079

PROBLEM STATUS SECTION

BLOCK STATUS

```
*****  
**  
*  
*  
* Calculations were completed normally  
*  
*  
* All Unit Operation blocks were completed normally  
*  
*  
* All streams were flashed normally  
*  
*  
* Properties estimation was completed normally  
*  
*  
*****  
**
```

Appendix 9: Material Safety Data Sheets

Material Safety Data Sheet

Science Stuff, Inc.
1104 Newport Ave
Austin, TX 78753

Phone
Chemtrec 800-424-9300
24 Hour Emergency Assistance

Section 1 Identification					
Product Number:	C2656		Health: 2		
Product Name:	Sodium Iodide Laboratory Grade, Granular		Flammability 0		
			Reactivity 0		
Trade/Chemical Synonyms			Hazard Rating:		
Formula:	NaI		Least Slight Moderate High Extreme		
RTECS:	WB6475000		0 1 2 3 4		
C.A.S	CAS# 7681-82-5		NA = Not Applicable NE = Not Established		
Section 2 Component Mixture					
Sara 313	Component	CAS Number	%	Dim	Exposure Limits:
<input type="checkbox"/>	Sodium Iodide	CAS# 7681-82-5	100%	W/W	TXDS: orl-rat LD $\blacklozenge\blacklozenge$: 4340 mg/Kg
Section 3 Hazard Identification (Also see section 11)					
Harmful if swallowed. May cause irritation. Avoid breathing vapors, or dusts. Use with adequate ventilation. Avoid contact with eyes, skin, and clothes. Wash thoroughly after handling. Keep container closed.					
Section 4 First Aid Measures					
Harmful if swallowed. May cause irritation. Avoid breathing vapors, or dusts. Use with adequate ventilation. Avoid contact with eyes, skin, and					

Section 6 Accidental Release Me

Dispose of in a manner consistent with state and local regulations.

Section 7 Handling and Storage

Store in a cool, dry, well-ventilated area, away from incompatible materials. Wear appropriate PPE during handling.

Section 8 Exposure Controls & P

Respiratory Protection: NIOSH/MSHA approved respirator

Mechanical:

Local Protection

Ventilation: Local

Exhaust: Protection

Other Protective Equipment: Use

Section 9 Physical and Chemical

Melting Point: 651 \blacklozenge C Specific Gravity:

Boiling Point: 1300 \blacklozenge C Percent Volatile Volume:

Vapor Pressure: Information not available Evaporation Rate:

Vapor Information Evaporation

clothes. Wash thoroughly after handling. Keep container closed.

FIRST AID: SKIN: Remove contaminated clothing. Wash exposed area with soap and water. If symptoms persist, seek medical attention

EYES: Wash eyes with plenty of water for at least 15 minutes, lifting lids occasionally. Seek Medical Aid. INHALATION: Remove to fresh air. If not breathing, give artificial respiration. If breathing is difficult, give oxygen

INGESTION: If swallowed, induce vomiting immediately after giving two glasses of water. Never give anything by mouth to an unconscious person.

Section 5 Fire Fighting Measures	
Fire Extinguisher Type:	Any means suitable for extinguishing surrounding fire
Fire/Explosion Hazards:	None
Fire Fighting Procedure:	Wear self-contained breathing apparatus and protective clothing to prevent contact with skin and clothing.

Density:	not available	Standard
Solubility in Water:	Soluble	Auto ign. Temper
Appearance and Odor:	White crystals / No odor	Lower Flamm. Limit in
Flash Point:	Information not available	Upper Flamm. Limit in

Section 10 Stability and Reactivity	
Stability:	Stable Conditions to Avoid: Moisture
Materials to Avoid:	
Hazardous Decomposition Products:	Iodine and Sodium Oxide fumes
Hazardous Polymerization:	Will not polymerize
Condition to Avoid:	None known

Section 11 Additional Information	
Conditions aggravated/Target organs:	preexisting skin, eye or respiratory system may be more susceptible. Acute: Irritation of mucous membranes and digestive tract. Chronic: Iodism, bronchitis, and asthma
DOT Classification:	Not Regulated
DOT regulations may change from time to time. Please consult the most recent version of relevant regulations.	
Revision No:	Date Entered: 9/1/2006

The information contained herein is believed to be accurate and is offered in good faith for the user's consideration and investigation. No warranty is expressed or implied regarding the completeness or accuracy of this information, whether originating from Science Stuff, Inc. or from an alternate source. Users of this material should satisfy themselves by independent investigation of current scientific and medical information that this material may be safely handled.

yes	S3050	SELECT CODE, [F
-----	-------	-----------------

Material Safety Data Sheet

Toluene-2,4-diisocyanate MSDS

Section 1: Chemical Product and Company Identification

Product Name: Toluene-2,4-diisocyanate

Catalog Codes: SLT1264

CAS#: 584-84-9

RTECS: CZ6300000

TSCA: TSCA 8(b) inventory: Toluene-2,4-diisocyanate

CI#: Not available.

Synonym: Toluene-2,4-diisocyanate

Chemical Formula: C₉H₆N₂O₂

Contact Information:

Sciencelab.com, Inc.

14025 Smith Rd.

Houston, Texas 77396

US Sales: **1-800-901-7247**

International Sales: **1-281-441-4400**

Order Online: ScienceLab.com

CHEMTREC (24HR Emergency Telephone), call:

1-800-424-9300

International CHEMTREC, call: 1-703-527-3887

For non-emergency assistance, call: 1-281-441-4400

Section 2: Composition and Information on Ingredients

Composition:

Name CAS # % by Weight

Toluene-2,4-diisocyanate 584-84-9 100

Toxicological Data on Ingredients: Toluene-2,4-diisocyanate: ORAL (LD50): Acute: 5800 mg/kg [Rat]. VAPOR (LC50):

Acute: 14 ppm 4 hour(s) [Rat]. 10 ppm 4 hour(s) [Mouse].

Section 3: Hazards Identification

Potential Acute Health Effects:

Extremely hazardous in case of ingestion. Very hazardous in case of skin contact (irritant), of eye contact (irritant), of inhalation. Hazardous in case of skin contact (permeator). Slightly hazardous in case of skin contact

(corrosive). Severe over-exposure can result in death. Inflammation of the eye is characterized by redness,

watering, and itching. Skin inflammation is characterized by itching, scaling, reddening, or, occasionally, blistering.

Potential Chronic Health Effects:

CARCINOGENIC EFFECTS: Classified 2 (Reasonably anticipated.) by NTP.

MUTAGENIC EFFECTS: Not available.

TERATOGENIC EFFECTS: Not available.

DEVELOPMENTAL TOXICITY: Not available.

The substance is toxic to lungs, the nervous system, liver, mucous membranes.

Repeated or prolonged exposure to the substance can produce target organs damage. Repeated exposure to an

highly toxic material may produce general deterioration of health by an accumulation in one or many human

p. 1

organs.

Section 4: First Aid Measures

Eye Contact: Check for and remove any contact lenses. Do not use an eye ointment. Seek medical attention.

Skin Contact:

After contact with skin, wash immediately with plenty of water. Gently and thoroughly wash the contaminated skin with running water and non-abrasive soap. Be particularly careful to clean folds, crevices, creases and groin.

Cover the irritated skin with an emollient. If irritation persists, seek medical attention. Wash contaminated clothing before reusing.

Serious Skin Contact:

Wash with a disinfectant soap and cover the contaminated skin with an anti-bacterial cream. Seek immediate medical attention.

Inhalation: Allow the victim to rest in a well ventilated area. Seek immediate medical attention.

Serious Inhalation:

Evacuate the victim to a safe area as soon as possible. Loosen tight clothing such as a collar, tie, belt or waistband. If breathing is difficult, administer oxygen. If the victim is not breathing, perform mouth-to-mouth

resuscitation. WARNING: It may be hazardous to the person providing aid to give mouth-to-mouth resuscitation

when the inhaled material is toxic, infectious or corrosive. Seek immediate medical attention.

Ingestion:

Do not induce vomiting. Examine the lips and mouth to ascertain whether the tissues are damaged, a possible

indication that the toxic material was ingested; the absence of such signs, however, is not conclusive.

Loosen

tight clothing such as a collar, tie, belt or waistband. If the victim is not breathing, perform mouth-to-mouth resuscitation. Seek immediate medical attention.

Serious Ingestion: Not available.

Section 5: Fire and Explosion Data

Flammability of the Product: May be combustible at high temperature.

Auto-Ignition Temperature: 620°C (1148°F)

Flash Points: CLOSED CUP: 127°C (260.6°F). OPEN CUP: 135°C (275°F).

Flammable Limits: LOWER: 0.9% UPPER: 9.5%

Products of Combustion: These products are carbon oxides (CO, CO₂), nitrogen oxides (NO, NO₂...).

Fire Hazards in Presence of Various Substances: Slightly flammable to flammable in presence of oxidizing materials.

Explosion Hazards in Presence of Various Substances:

Risks of explosion of the product in presence of mechanical impact: Not available.

Risks of explosion of the product in presence of static discharge: Not available.

Slightly explosive to explosive in presence of oxidizing materials.

Fire Fighting Media and Instructions:

SMALL FIRE: Use DRY chemical powder.

LARGE FIRE: Use water spray, fog or foam. Do not use water jet.

Special Remarks on Fire Hazards: Not available.

Special Remarks on Explosion Hazards: Not available.

p. 2

Section 6: Accidental Release Measures

Small Spill: Absorb with an inert material and put the spilled material in an appropriate waste disposal.

Large Spill:

If the product is in its solid form: Use a shovel to put the material into a convenient waste disposal container. If

the product is in its liquid form: Absorb with an inert material and put the spilled material in an appropriate waste

disposal. Be careful that the product is not present at a concentration level above TLV. Check TLV on the MSDS and with local authorities.

Section 7: Handling and Storage

Precautions:

Keep locked up Keep container dry. Keep away from heat. Keep away from sources of ignition. Empty containers pose a fire risk, evaporate the residue under a fume hood. Ground all equipment containing material.

Do not ingest. Do not breathe gas/fumes/ vapour/spray. Never add water to this product In case of insufficient ventilation, wear suitable respiratory equipment If ingested, seek medical advice immediately and show the container or the label. Avoid contact with skin and eyes Keep away from incompatibles such as moisture.

Storage:

Keep container dry. Keep in a cool place. Ground all equipment containing material. Keep container tightly closed. Keep in a cool, well-ventilated place. Highly toxic or infectious materials should be stored in a separate locked safety storage cabinet or room.

Section 8: Exposure Controls/Personal Protection

Engineering Controls:

Provide exhaust ventilation or other engineering controls to keep the airborne concentrations of vapors below their respective threshold limit value. Ensure that eyewash stations and safety showers are proximal to the work-station location.

Personal Protection:

Splash goggles. Lab coat. Vapor respirator. Be sure to use an approved/certified respirator or equivalent. Gloves.

Personal Protection in Case of a Large Spill:

Splash goggles. Full suit. Vapor respirator. Boots. Gloves. A self contained breathing apparatus should be used to avoid inhalation of the product. Suggested protective clothing might not be sufficient; consult a specialist BEFORE handling this product.

Exposure Limits:

TWA: 0.02 (ppm)

TWA: 0.14 (mg/m³)

Consult local authorities for acceptable exposure limits.

Section 9: Physical and Chemical Properties

Physical state and appearance: Liquid.

Odor: Not available.

Taste: Not available.

Molecular Weight: 174.16 g/mole

Color: Colorless to light yellow.

pH (1% soln/water): Not applicable.

p. 3

Boiling Point: 251°C (483.8°F)

Melting Point: 19.4°C (66.9°F)

Critical Temperature: Not available.

Specific Gravity: 1.2244 (Water = 1)

Vapor Pressure: 0.01 mm of Hg (@ 20°C)

Vapor Density: 6 (Air = 1)

Volatility: Not available.

Odor Threshold: 0.449 ppm

Water/Oil Dist. Coeff.: Not available.

Ionicity (in Water): Not available.

Dispersion Properties: Not available.

Solubility: Insoluble in cold water.

Section 10: Stability and Reactivity Data

Stability: The product is stable.

Instability Temperature: Not available.

Conditions of Instability: Not available.

Incompatibility with various substances: Highly reactive with moisture.

Corrosivity: Non-corrosive in presence of glass.

Special Remarks on Reactivity: Not available.

Special Remarks on Corrosivity: Not available.

Polymerization: Yes.

Section 11: Toxicological Information

Routes of Entry: Dermal contact. Eye contact. Inhalation. Ingestion.

Toxicity to Animals:

WARNING: THE LC50 VALUES HEREUNDER ARE ESTIMATED ON THE BASIS OF A 4-HOUR EXPOSURE.

Acute oral toxicity (LD50): 5800 mg/kg [Rat].

Acute toxicity of the vapor (LC50): 10 ppm 4 hour(s) [Mouse].

Chronic Effects on Humans:

CARCINOGENIC EFFECTS: Classified 2 (Reasonably anticipated.) by NTP.

The substance is toxic to lungs, the nervous system, liver, mucous membranes.

Other Toxic Effects on Humans:

Extremely hazardous in case of ingestion.

Very hazardous in case of skin contact (irritant), of inhalation.

Hazardous in case of skin contact (permeator).

p. 4

Slightly hazardous in case of skin contact (corrosive).

Special Remarks on Toxicity to Animals: Not available.

Special Remarks on Chronic Effects on Humans: Not available.

Special Remarks on other Toxic Effects on Humans: Not available.

Section 12: Ecological Information

Ecotoxicity: Not available.

BOD5 and COD: Not available.

Products of Biodegradation:

Possibly hazardous short term degradation products are not likely. However, long term degradation products may arise.

Toxicity of the Products of Biodegradation: The products of degradation are more toxic.

Special Remarks on the Products of Biodegradation: Not available.

Section 13: Disposal Considerations

Waste Disposal:

Section 14: Transport Information

DOT Classification: CLASS 6.1: Poisonous material.

Identification: : Toluene diisocyanate : UN2078 PG: II

Special Provisions for Transport: Not available.

Section 15: Other Regulatory Information

Federal and State Regulations:

California prop. 65: This product contains the following ingredients for which the State of California has found to

cause cancer, birth defects or other reproductive harm, which would require a warning under the statute:

Toluene-2,4-diisocyanate

California prop. 65: This product contains the following ingredients for which the State of California has found to

cause cancer which would require a warning under the statute: Toluene-2,4-diisocyanate

Pennsylvania RTK: Toluene-2,4-diisocyanate

Massachusetts RTK: Toluene-2,4-diisocyanate

TSCA 8(b) inventory: Toluene-2,4-diisocyanate

SARA 302/304/311/312 extremely hazardous substances: Toluene-2,4-diisocyanate

SARA 313 toxic chemical notification and release reporting: Toluene-2,4-diisocyanate

CERCLA: Hazardous substances.: Toluene-2,4-diisocyanate

Other Regulations: OSHA: Hazardous by definition of Hazard Communication Standard (29 CFR 1910.1200).

Other Classifications:

WHMIS (Canada):

CLASS D-1A: Material causing immediate and serious toxic effects (VERY TOXIC).

CLASS D-2A: Material causing other toxic effects (VERY TOXIC).

DSCL (EEC):

p. 5

R26- Very toxic by inhalation.

R38- Irritating to skin.

R41- Risk of serious damage to eyes.

R45- May cause cancer.

HMS (U.S.A.):

Health Hazard: 3

Fire Hazard: 1

Reactivity: 2

Personal Protection: h

National Fire Protection Association (U.S.A.):

Health: 3

Flammability: 1

Reactivity: 2

Specific hazard:

Protective Equipment:

Gloves.

Lab coat.

Vapor respirator. Be sure to use an approved/certified respirator or equivalent. Wear appropriate respirator when ventilation is inadequate.

Splash goggles.

Section 16: Other Information

References: Not available.

Other Special Considerations: Not available.

Created: 10/10/2005 12:06 AM

Last Updated: 11/06/2008 12:00 PM

The information above is believed to be accurate and represents the best information currently available to us. However, we make no warranty of merchantability or any other warranty, express or implied, with respect to such information, and we assume no liability resulting from its use. Users should make their own investigations to determine the suitability of the information for their particular purposes. In no event shall ScienceLab.com be liable for any claims, losses, or damages of any third party or for lost profits or any special, indirect, incidental, consequential or exemplary damages, howsoever arising, even if ScienceLab.com has been advised of the possibility of such damages.

Material Safety Data Sheet Gaseous Oxygen

Section 1 : PRODUCT AND COMPANY IDENTIFICATION

Section 2 : COMPOSITION/ INGREDIENT INFORMATION

Section 3 : HAZARD IDENTIFICATION

Section 4 : FIRST AID MEASURES

Section 5 : FIRE FIGHTING MEASURES

Section 6 : ACCIDENTAL RELEASE MEASURES

Section 7 : HANDLING AND STORAGE

Section 8 : EXPOSURE CONTROLS / PERSONAL PROTECTION

Section 9 : PHYSICAL AND CHEMICAL PROPERTIES

Section 10 : STABILITY AND REACTIVITY

Section 11 : TOXICOLOGICAL INFORMATION

Section 13 : DISPOSAL CONSIDERATIONS

Section 14 : TRANSPORT INFORMATION

Section 15 : REGULATORY INFORMATION

Section 16 : OTHER INFORMATION

Section 1 : PRODUCT AND COMPANY IDENTIFICATION

Product name: Oxygen (Gaseous),

Supplier/ Manufacturer: Universal Industrial Gases, Inc.
2200 Northwood Avenue, Suite
3
Easton, PA 18045-2239 USA

Emergency phone: (610) 559-7967.

Section 2 : COMPOSITION/ INGREDIENT INFORMATION

C.A.S.	CONCENTRATION %	Ingredient Name	OSHA PEL	ACGIH TLV	OSHA STEL
--------	-----------------	-----------------	----------	-----------	-----------

7782-44-7	Typically > 99 (MSDS also applies to 90 - 99%)	OXYGEN (+N ₂ & Ar)	NONE	NONE	NONE
-----------	---------------------------------------------------	----------------------------------	------	------	------

Section 3 : HAZARD IDENTIFICATION

Emergency Overview: Oxygen gas is colorless, odorless, non-toxic cryogenic liquid or colorless, odorless, oxidizing gas. Liquid releases will quickly vaporize to gas.

The chief physical hazard associated with releases of the gas is its oxidizing power which can greatly accelerate the burning rate for both common and exotic combustible materials. Emergency personnel must practice extreme caution when approaching oxygen releases because of the potential for intense fire.

The primary health hazard at atmospheric pressure is respiratory system irritation after exposure to high oxygen concentrations. Maintain oxygen levels in air above 19.5% and below 23.5%. While up to 50% oxygen can be breathed for more than 24 hours without adverse effects, high concentrations in open air accelerate combustion and increase the risk of fire and explosion of combustible or flammable materials.

Route of entry: Inhalation, skin and eye contact.

Effects of acute exposure

Eye contact: No adverse effects expected.

Skin contact: No adverse effects expected. .

Inhalation: May cause breathing difficulty.

Prolonged exposure to high oxygen levels (>75%) can cause central nervous system depression: signs/symptoms can include headache, dizziness, drowsiness, poor coordination, slowed reaction time, slurred speech, giddiness and unconsciousness.

May cause coughing and chest pain.

May cause lung damage.

May cause soreness of the throat.

Ingestion: Not a likely route of exposure.

Effects of chronic exposure: None known.

Reproductive effects: Oxygen deficiency during pregnancy has produced developmental abnormalities in humans and experimental animals.

Section 4 : FIRST AID MEASURES

Skin contact: None required.

Eye contact: None required.

Inhalation: **RESCUERS SHOULD NOT ATTEMPT TO RETRIEVE VICTIMS OF EXPOSURE TO THIS PRODUCT WITHOUT ADEQUATE PERSONAL PROTECTIVE EQUIPMENT. At a minimum, Self-Contained Breathing Apparatus should be worn.**

Remove victim(s) to fresh air, as quickly as possible. If not breathing qualified personnel should administer artificial respiration. Get medical attention.
Keep person warm and at rest.

Ingestion: No first aid should be needed.

Not considered a potential route of exposure.

Section 5 : FIRE FIGHTING MEASURES

Flammability: Oxidizer.

Conditions of flammability: Contact with flammable materials.
Vigorously accelerates combustion.

Extinguishing media: Use appropriate extinguishing media for surrounding fire.

Special procedures: Self-contained breathing apparatus required.

Firefighters should wear the usual protective gear.

Cool fire exposed containers with water spray.

Personnel should be evacuated, if necessary, to upwind area.

Remove containers from fire area if without risk.

Auto-ignition temperature: Not applicable.

Flash point (°C), method: Not applicable.

Lower flammability limit (% vol): Not applicable.

Upper flammability limit (% vol): Not applicable.

Explosion Data

Sensitivity to mechanical impact: Avoid impact against container.

Explosive power: Closed containers may rupture or explode due to pressure build-up when exposed to extreme heat.

Cylinders are equipped with temperature and pressure relief devices but may still rupture under fire conditions.

Section 6 : ACCIDENTAL RELEASE MEASURES

Leak/Spill: Evacuate all non-essential personnel.

Stop leak without risk.

Wear gloves and goggles

Use a self-contained breathing apparatus.

Ventilate area. Monitor the surrounding area for Oxygen level

Section 7 : HANDLING AND STORAGE

Handling procedures and equipment: Protect system components against physical damage.

Use adequate ventilation.

Avoid inhalation.

Never work on a pressurized system.

If there is a leak, close the upstream valve, blow down the system by venting to a safe place, then repair the leak.

Storage requirements: Use storage containers, piping, valves and fittings designed for storage and distribution of Gaseous Oxygen. Protect cylinders against physical damage. Store in cool, dry, well-ventilated, fireproof area, away from flammable materials and corrosive atmospheres. Store away from heat and ignition sources and out of direct sunlight. Do not store near elevators, corridors or loading docks. Do not allow area where cylinders are stored to exceed 52°C (125°F).

Move cylinders with a suitable hand-truck. Do not drag, slide or roll cylinders. Do not drop cylinders or permit them to strike each other. Secure cylinders firmly. Leave the valve protection cap in-place (where provided) until cylinder is placed into service and after it is taken out of service.

Use designated CGA fittings and other support equipment. Do not use adapters. Do not heat cylinder by any means to increase the discharge rate of the product from the cylinder. Use check valve or trap in discharge line to prevent hazardous backflow into the cylinder. Do not use oils or grease on gas-handling fittings or equipment.

After use, close main cylinder valve. Replace valve protection cap (where provided). Mark empty cylinders "EMPTY".

Section 8 : EXPOSURE CONTROLS / PERSONAL PROTECTION

Precautionary Measures

Gloves/Type:

Wear appropriate gloves.

Respiratory/Type: NIOSH/MSHA approved respirator.

Eye/Type: As per local regulations.

Footwear/Type: Safety boots per local regulations.

Clothing/Type: Wear adequate protective clothes.

Other/Type: Eye wash facility should be in close proximity.

Emergency shower should be in close proximity.

Ventilation requirements: Mechanical ventilation is satisfactory. Ensure oxygen concentration remains above 19.5% and Carbon Dioxide concentration does not exceed 5000 ppm,

Local exhaust at points of emission preferred.

Exposure limit of material Not available.

Section 9 : PHYSICAL AND CHEMICAL PROPERTIES

Physical state: Gas

Appearance & odor: Colorless, odorless gas.

Odor threshold (PPM): Odorless.

Vapor pressure : Gas@ 70°F (21°C)

Vapor sp. gravity (air=1): 1.11 @ 70°F (21°C)

Volatiles (% by volume) 100%

Boiling point : -183°C (760 mmHg)

-297.4°F

Freezing point : -218.8°C

-361.8°F

Solubility in water (%): Slight.

Section 10 : STABILITY AND REACTIVITY

Chemical stability: Product is stable.

Conditions of reactivity: Heat

Hazardous polymerization: Will not occur.

Incompatible substances: Combustible materials.

Oils or grease.

Flammable materials.

Hazardous decomposition products: None.

Section 11 : TOXICOLOGICAL INFORMATION

LD50 of product, species & route: Not available.

LC50 of product, species & route: Not available.

Section 13 : DISPOSAL CONSIDERATIONS

Waste disposal: Gas will dissipate in air. Cylinders should be returned in the original shipping container, properly labeled, with any valve outlet plugs or caps secured and valve protection cap in place.

Section 14 : TRANSPORT INFORMATION

DOT/ TDG classification:

For cylinder shipments:
Oxygen, compressed
UN1072
Class 2.2 (Non-Flammable Gas)
with subsidiary risk 5.1 (Oxidizer)

**North American
Emergency Response [122](#)
Guidebook Number:**

Section 15 : REGULATORY INFORMATION

WHMIS classification:

A,
C

DSL status:Appears on DSL.

Section 16 : OTHER INFORMATION**Definitions and other useful data:**

CAS #: The Chemical Abstract Service Number which uniquely identifies each constituent.

ACGIH - American Conference of Governmental Industrial Hygienists, a professional association which establishes exposure limits.

TLV - Threshold Limit Value - an airborne concentration of a substance which represents conditions under which it is generally believed that nearly all workers may be repeatedly exposed without adverse effect.

OSHA - U.S. Occupational Safety and Health Administration.

PEL - Permissible Exposure Limit - The same value as a TLV, except it is enforceable by OSHA.

IDLH - Immediately Dangerous to Life and Health - A concentration from which one can escape within 30-minutes without suffering permanent injury.

NATIONAL FIRE PROTECTION ASSOCIATION:**Health Hazard Rating Scale (Blue):**

0 (material that on exposure under fire conditions would offer no hazard beyond that of ordinary combustible materials);

1 (material that on exposure under fire conditions could cause irritation or minor residual injury);

2 (materials that on intense or continued exposure under fire conditions could cause temporary incapacitation or possible residual injury);

3 (materials that can on short exposure could cause serious temporary or residual injury);

4 (materials that under very short exposure could cause death or major residual injury).

Flammability Hazard Rating Scale (Red):

0 (minimal hazard);

1 (materials that require substantial pre-heating before burning);

2 (combustible liquid or solids; liquids with a flash point of 38-93°C [100-200°F]);

3 (Class IB and IC flammable liquids with flash points below 38°C [100°F]);

4 (Class IA flammable liquids with flash points below 23°C [73°F] and boiling points below 38°C [100°F]).

Reactivity Hazard Rating Scale (Yellow):

0 (normally stable);

1 (material that can become unstable at elevated temperatures or which can react slightly with water);

2 (materials that are unstable but do not detonate or which can react violently with water);

3 (materials that can detonate when initiated or which can react explosively with water);

4 (materials that can detonate at normal temperatures or pressures).

TOXICOLOGICAL INFORMATION:

Possible health hazards as derived from human data, animal studies, or from the results of studies with similar compounds are presented. Definitions of some terms:

LD50 -Lethal Dose (solids & liquids) which kills 50% of the exposed animals;

LC50 - Lethal Concentration (gases) which kills 50% of the exposed animals;

ppm concentration expressed in parts of material per million parts of air or water;

mg/m³ concentration expressed in weight of substance per volume of air;

mg/kg quantity of material, by weight.

REGULATORY INFORMATION:

EPA is the U.S. Environmental Protection Agency.

WHMIS is the Canadian Workplace Hazardous Materials Information System.

DOT and **TC** are the U.S. Department of Transportation and the Transport Canada, respectively, which assign DOT and **TDG** (Transportation of Dangerous Goods) identification numbers, hazard classifications, and proper shipping name and shipping label information. This material is hazardous as defined by 49 CFR 172.101 of the US Department of Transportation and Dangerous Goods as defined by Transport Canada Transportation of Dangerous Goods Regulations.

USE OF THIS INFORMATION:

Universal Industrial Gases, Inc. offers this information to customers, employees, contractors, and the general public to promote the safe use of this product through awareness of product hazards and safety information. Customers and others who use or transport or sell this product to others should: 1) Disseminate this information internally to all workplace areas, employees, agents and contractors likely to encounter this product; 2) Provide supplemental hazards awareness, safety information, operation and maintenance procedures to the workplace areas and employees, agents and contractors likely to encounter this product; 3) Furnish this information to all their customers who purchase this product; and 4) Ask each purchaser or user of the product to notify its employees and customers of the product hazards and safety information.

Your browser does not support script

DISCLAIMER OF EXPRESSED AND IMPLIED WARRANTIES:

Universal Industrial Gases, Inc. has taken reasonable care in preparing this document, however, since the use of this information and the conditions of use of the product are not within the control of Universal Industrial Gases, Inc., it is the user's obligation to determine the conditions of safe use of this product. The information in this document is offered with no warranties or representations as to accuracy or completeness and it is the responsibility of

each individual to determine the suitability of the information for their particular purpose(s).

MATERIAL SAFETY DATA SHEET**PRODUCT NAME:** CARBON MONOXIDE**1. Chemical Product and Company Identification****BOC Gases, Division of The BOC Group, Inc. 575 Mountain Avenue Murray Hill, NJ 07974****TELEPHONE NUMBER:** (908) 464-8100**BOC Gases Division of BOC Canada Limited 5975 Falbourne Street, Unit 2 Mississauga, Ontario L5R 3W6****TELEPHONE NUMBER:** (905) 501-1700 **24-HOUR EMERGENCY TELEPHONE NUMBER:****CHEMTREC (800) 424-9300 24-HOUR EMERGENCY TELEPHONE NUMBER:** (905) 501-0802**EMERGENCY RESPONSE PLAN NO:** 20101**PRODUCT NAME:** CARBON MONOXIDE **CHEMICAL NAME:** Carbon Monoxide **COMMON****NAMES/SYNONYMS:** Carbonic Oxide, Exhaust Gas, Flue Gas **TDG (Canada) CLASSIFICATION:** 2.3 (2.1)**WHMIS CLASSIFICATION:** A, D1A, D2A, D2B, B1**PREPARED BY:** Loss Control (908)464-8100/(905)501-1700 **PREPARATION DATE:** 6/1/95 **REVIEW****DATES:** 6/7/96**2. Composition, Information on Ingredients****INGREDIENT % VOLUME PEL-OSHA**

1

TLV-ACGIH**Route/Species** Carbon Monoxide**FORMULA:** CO **CAS:** 630-08-0 **RTECS #:** FG3500000

1

100.0 50 ppm TWA 25 ppm TWA LC

As stated in 29 CFR 1910, Subpart Z (revised July 1, 1993)

As stated in the ACGIH 1994-95 Threshold Limit Values for Chemical

3. Hazards Identification

Substances and Physical Agents

EMERGENCY OVERVIEW Inhaled Carbon Monoxide binds to the blood hemoglobin, greatly reducing the red blood cell's ability to transport oxygen to body tissues. Effects may include headaches, dizziness, convulsions, loss of consciousness and death. Extremely flammable gas.**MSDS:** G-112 **Revised:** 6/7/96 Page 1 of 6

2

LD

50

50

or LC

1807 ppm/4H (rat)

50

PRODUCT NAME: CARBON MONOXIDE**ROUTE OF ENTRY:** Skin Contact

No Skin Absorption

HEALTH EFFECTS: Exposure Limits

No Eye Contact

Yes Irritant

No Inhalation

Yes Ingestion

No Sensitization

No Teratogen

Synergistic Effects None Reported

Yes Reproductive Hazard

Carcinogenicity: -- NTP: No IARC: No OSHA: No

EYE EFFECTS: None reported.**SKIN EFFECTS:** None reported.**INGESTION EFFECTS:** None reported.

Yes Mutagen Yes

INHALATION EFFECTS: Inhaled carbon monoxide binds with blood hemoglobin to form carboxyhemoglobin.

Carboxyhemoglobin can not take part in normal oxygen transport, greatly reducing the blood's ability to transport

oxygen. Depending on levels and duration of exposure, symptoms may include headache, dizziness, heart palpitations, weakness, confusion, nausea, and even convulsions, eventual unconsciousness and death. Some experimental evidence indicating teratogenic and reproductive effects.

NFPA HAZARD CODES HMIS HAZARD CODES RATINGS SYSTEM

Health: 2 Health: 2 0 = No Hazard Flammability: 4 Flammability: 4 1 = Slight Hazard Reactivity: 0 Reactivity: 0 2 = Moderate Hazard

4. First Aid Measures

EYES: None required.

SKIN EFFECTS: None required.

INGESTION: None required.

3 = Serious Hazard 4 = Severe Hazard

MSDS: G-112 Revised: 6/7/96 Page 2 of 6

No

PRODUCT NAME: CARBON MONOXIDE

INGESTION EFFECTS: None required.

INHALATION: Conscious persons should be assisted to an uncontaminated area and be treated with supplemental oxygen. Quick removal from the contaminated area is most important. Unconscious persons should be moved to an uncontaminated area and be given artificial respiration and oxygen at the same time. The administering of the oxygen at an elevated pressure (up to 2 to 2.5 atmospheres) has shown to be beneficial as has treatment in a hyperbaric chamber. The physician should be informed that the patient has inhaled toxic quantities of carbon monoxide. PROMPT MEDICAL ATTENTION IS MANDATORY IN ALL CASES OF OVEREXPOSURE TO CARBON MONOXIDE. RESCUE PERSONNEL SHOULD BE EQUIPPED WITH SELF-CONTAINED BREATHING APPARATUS AND BE COGNIZANT OF EXTREME FIRE AND EXPLOSION HAZARD.

5. Fire Fighting Measures

Conditions of Flammability: Flammable gas Flash point:

Not Available Method: Not Applicable

Autoignition: Temperature: 116

C) LEL(%): 12.5 UEL(%): 74.0 Hazardous combustion products: None Sensitivity to mechanical shock: None

Sensitivity to static discharge: Not Available

FIRE AND EXPLOSION HAZARDS: Having almost the same density as air, it will not diffuse by rising as with some lighter flammable gases such as hydrogen or natural gas (methane). Flammable in air over a very wide range. It reacts violently with oxygen difluoride and barium peroxide.

EXTINGUISHING MEDIA: Water, dry chemical, carbon dioxide.

FIRE FIGHTING INSTRUCTIONS: If possible, stop flow of gas; use water spray to cool surrounding containers.

6. Accidental Release Measures

Evacuate all personnel from affected area. Use appropriate protective equipment. If leak is in user's equipment, be certain to purge piping with inert gas prior to attempting repairs. If leak is in container or container valve, contact the appropriate emergency telephone number listed in Section 1 or call your closest BOC location.

7. Handling and Storage

Electrical Classification: Class 1, Group C

Earth-ground and bond all lines and equipment associated with the carbon monoxide system. Electrical equipment should be non sparking or explosion proof.

MSDS: G-112 Revised: 6/7/96 Page 3 of 6

F (639

o

PRODUCT NAME: CARBON MONOXIDE

Carbon Monoxide can be handled in all commonly used metals up to approximately 500 psig (3450 kPa). Above that pressure it forms toxic and corrosive carbonyl compounds with some metals. Carbon steels, aluminum alloys, copper and copper alloys, low carbon stainless steels and nickel-based alloys such as Hastelloy A, B & C are recommended for higher pressure applications.

Protect cylinders from physical damage. Store in cool, dry, well-ventilated areas away from heavily trafficked areas and emergency exits. Do not allow the temperature where cylinders are stored to exceed 130

C). Cylinders should be stored upright and firmly secured to prevent falling or being knocked over. Full and empty cylinders should be segregated. Use a "first in-first out" inventory system to prevent full cylinders being stored for

excessive periods of time. Post "NO SMOKING OR OPEN FLAMES" signs in the storage area or use area. There should be no sources of ignition in the storage area or use area.

Use only in well-ventilated areas. Valve protection caps must remain in place unless container is secured with valve outlet piped to use point. Do not drag, slide or roll cylinders. Use a suitable hand truck for cylinder movement. Use a pressure reducing regulator when connecting cylinder to lower pressure (<3000 psig) piping or systems. Do not heat cylinder by any means to increase the discharge rate of product from the cylinder. Use a check valve or trap in the discharge line to prevent hazardous back flow into the system.

ENGINEERING CONTROLS: Hood with forced ventilation. Use local exhaust to prevent accumulation above the exposure limit. Use general mechanical ventilation in accordance with electrical codes.

8. Exposure Controls, Personal Protection

EXPOSURE LIMITS

1

:

INGREDIENT % VOLUME PEL-OSHA

2

TLV-ACGIH

Route/Species Carbon Monoxide

FORMULA: CO **CAS:** 630-08-0 **RTECS #:** FG3500000

1

100.0 50 ppm TWA 25 ppm TWA LC

Refer to individual state of provincial regulations, as applicable, for limits which may be more stringent than those listed here.

2

3

As stated in 29 CFR 1910, Subpart Z (revised July 1, 1993)

As stated in the ACGIH 1994-1995 Threshold Limit Values for Chemical Substances and Physical Agents.

EYE/FACE PROTECTION: Safety goggles or glasses.

SKIN PROTECTION: Any material protective gloves.

RESPIRATORY PROTECTION: Positive pressure air line with full-face mask and escape bottle or self-contained breathing apparatus should be available for emergency use.

OTHER/GENERAL PROTECTION: Safety shoes.

MSDS: G-112 **Revised:** 6/7/96 Page 4 of 6

3

o

F (54

LD

50

50

o

or LC

1807 ppm/4H (rat)

50

PRODUCT NAME: CARBON MONOXIDE

9. Physical and Chemical Properties

PARAMETER VALUE UNITS Physical state (gas, liquid, solid) : Gas

Vapor pressure : >220.4 psia Vapor density (Air = 1) : Not Available Evaporation point : Not Available Boiling point : -312.7

C Freezing point : -337.1

: -191.5

C pH : Not Available Specific gravity : 0.96 Oil/water partition coefficient : Not Available Solubility (H2O) :

Very slight Odor threshold : Not Applicable Odor and appearance : Odorless; colorless gas

10. Stability and Reactivity

STABILITY: Stable

INCOMPATIBLE MATERIALS: Oxidizers

HAZARDOUS DECOMPOSITION PRODUCTS: Carbon dioxide

HAZARDOUS POLYMERIZATION: Will not occur.

11. Toxicological Information

: -205.1

o

o

o

o

F

F

REPRODUCTIVE: Inhalation of 150 ppm carbon monoxide for 24 hours by pregnant rats produced cardiovascular and behavioral defects in offspring. Toxic effects to fertility were observed in female rats exposed to 1 mg/m

for 24 hours. Similar effects observed in other mammalian species.

MUTAGENIC: Genetic changes observed in mammalian cell assay systems at exposures of 1500 to 2500 ppm for 10 minutes.

OTHER: Degenerative changes to the brain in rats chronically exposed to 30 mg/m

12. Ecological Information

No data given.

3

MSDS: G-112 Revised: 6/7/96 Page 5 of 6

3

PRODUCT NAME: CARBON MONOXIDE

13. Disposal Considerations

Do not attempt to dispose of residual waste or unused quantities. Return in the shipping container PROPERLY LABELED, WITH ANY VALVE OUTLET PLUGS OR CAPS SECURED AND VALVE PROTECTION CAP IN PLACE to BOC Gases or authorized distributor for proper disposal.

14. Transport Information

PARAMETER United States DOT Canada TDG

PROPER SHIPPING NAME: Carbon Monoxide Carbon Monoxide HAZARD CLASS: 2.3 2.3 (2.1) IDENTIFICATION NUMBER: UN 1016 UN 1016 SHIPPING LABEL: POISON GAS, FLAMMABLE GAS POISON GAS, FLAMMABLE GAS

Additional Marking Requirement: "Inhalation Hazard" Additional Shipping Paper Description Requirement: "Poison-Inhalation Hazard, Zone D"

15. Regulatory Information

SARA TITLE III NOTIFICATIONS AND INFORMATION

SARA TITLE III - HAZARD CLASSES: Acute Health Hazard Chronic Health Hazard Fire Hazard Sudden Release of Pressure Hazard

16. Other Information

Compressed gas cylinders shall not be refilled without the express written permission of the owner. Shipment of a compressed gas cylinder which has not been filled by the owner or with his/her (written) consent is a violation of transportation regulations.

DISCLAIMER OF EXPRESSED AND IMPLIED WARRANTIES: Although reasonable care has been taken in the preparation of this document, we extend no warranties and make no representations as to the accuracy or completeness of the information contained herein, and assume no responsibility regarding the suitability of this information for the user's intended purposes or for the consequences of its use. Each individual should make a determination as to the suitability of the information for their particular purpose(s).

MSDS: G-112 Revised: 6/7/96 Page 6 of 6

Product Safety Summary Toluene Diamine

This Product Safety Summary is intended to provide a general overview of the chemical substance. The information on the Summary is basic information and is not intended to provide emergency response information, medical information or treatment information. The summary should not be used to provide in-depth safety and health information. In-depth safety and health information can be found on the Material Safety Data Sheet (MSDS) for the chemical substance.

Chemical Identity

Abbreviation: TDA CAS Number : 25376-45-8 . Common Names: Diaminotoluene Toluenediamine isomers Methylphenylene diamine Tolyenediamine

Product Overview

- Pure toluene diamine is a highly poisonous, colorless solid which turns dark upon exposure to air.
- A majority of TDA produced in the United States is used as an 80% 2,4- and 20% 2,6-toluenediamine mixture to make toluene diisocyanate (TDI). A smaller amount is also made from a mixture of 65% 2,4- and 35% 2,6-toluenediamine. Some isolated 2,4-toluenediamine is used to produce pure 2,4-TDI. 2,4 is also used to make about 60 dyes, of which 28 are believed to be commercially significant. Other uses of TDA include enhancement of thermal stability in polyamides, fatigue resistance and dye ability in fibers, and the preparation of impact resistant resins, polyimides with superior wire coating properties, benzimidazolethiols (antioxidants), hydraulic fluids, urethane foams, fungicide stabilizers, and sensitizers for explosives.
- May be fatal if swallowed, inhaled or absorbed through skin. Causes irritation to the skin, eyes and respiratory tract. Combustible solid or liquid when heated. May cause methemoglobinemia. Affects blood, cardiovascular system, central nervous system, liver and kidneys.
- No airborne limits have been established for toluene diamine in the work environment. □ For further safety and health information, the current Material Safety Data Sheet (MSDS) should be used for this substance.

Physical/Chemical Properties

- TDA is a colorless solid which darkens on exposure to light or air. It has a weak amine or fish like odor.
- The specific gravity of TDA is 1.05 and is denser than water. TDA is soluble in water . □ The boiling point of TDA is 292C and the melting point is approximately 99C. The flash point of TDA is 149C, by the Tag Closed cup method.

Date: November 15, 2008 Page: 1 of 5

Health Information

TDA is a potentially hazardous material. A thorough knowledge of potential dangers, with strict adherence to recommended safety practices, is essential before aniline products are handled, stored or used. Workers must be properly instructed and supervised in the handling of TDA. No limits have been established for allowable concentrations in the work environment. The skin is a known route of exposure. TDA is listed as a category 2 carcinogen. Effects on the Respiratory System: Exposures to mists or dust can produce eye, nose or lung irritation. The hot liquid may cause severe skin burns. Symptoms may include bluish discoloration of lips and tongue, severe headache, nausea, confusion, dizziness, shock, respiratory paralysis, death. TDA affects the ability of the blood to carry oxygen. The effects may be delayed. Effects on the Skin: TDA may be absorbed through the skin. Symptoms of skin absorption parallel those from inhalation exposure. May cause skin irritation and local contact may cause dermatitis.

Effects on the Eyes: TDA vapor or dust is an eye irritant. May cause tearing and blurred vision. Splashes may cause corneal damage. Effects of Ingestion: TDA is toxic. Symptoms of ingestion parallel those of inhalation exposure. Chronic Hazards: TDA is a blood toxin, causing hemoglobin to convert to methemoglobin, resulting in cyanosis. Lengthy or repeated exposures may result in decreased appetite, anemia, weight loss, nervous system affects, and kidney, liver and bone marrow damage. Any exposure may cause an allergic skin reaction. This substance is possibly carcinogenic to humans. May cause genetic damage in humans.

Environmental Information

Do not wash away into sewer. Sweep spilled material into containers; if appropriate, moisten first to prevent dust generation. Then remove to a safe place. Do not let TDA enter the environment. TDA is expected to be very toxic to terrestrial and aquatic life. A variety of federal, state and local regulations govern the release of any material to the land, air or surface waters. Any release or discharge of TDA must be evaluated in reference to these regulations to determine appropriate response actions and reporting requirements. TDA is one of the chemicals for which releases to all environmental media must be annually reported. TDA has a reportable quantity (RQ) of 10 pounds per CERCLA. A regulation called Resource Conservation and Recovery Act (RCRA) must be followed if a volume of TDA or material contaminated with TDA is to be disposed of or discarded. Based on RCRA criteria, aniline or materials contaminated with TDA will likely be considered a "Hazardous Waste" upon disposal and will need to follow certain storage, handling and disposal restrictions as outlined in RCRA. Strict adherence to these restrictions as well as proper characterization and labeling of the material is the responsibility of the generator and handler of the waste material.

Date: November 15, 2008 Page: 2 of 5

Emphasis should be placed on the prevention of releases through careful design of equipment and sound operating procedures. If TDA is lost from containment through a leak or spill, care should be taken to use the proper personal protective equipment, decontamination procedures and other safety considerations. It is important to remember that spills of TDA and materials contaminated by TDA must be handled as RCRA hazardous wastes (U221). Any release of TDA greater than the "reportable quantity", 10 pounds, designated by the EPA in CERCLA or SARA should be reported immediately on discovery to the National Response Center and State Emergency Response Agency (see current MSDS for reportable quantity and pertinent phone numbers). In the event of accidental spillage of TDA to surface waters or to a municipal water system, contact the local and state pollution control agencies immediately.

Additional Hazard Information

Protect containers against physical damage. Store in a cool, dry well-ventilated location, away from any area where the fire hazard may be acute. Outside or detached storage is preferred. Containers should be bonded and grounded for transfers to avoid static sparks. Storage and use areas should be no smoking areas. Use non-sparking type tools and equipment, including explosion proof ventilation. Containers may be hazardous when empty since they retain product residues (vapors/liquids); observe all warnings and precaution listed for TDA.

Exposure Potential

Although potential for exposure does exist during TDA manufacture, transportation and use, enclosed systems limit the exposure to worker populations and nearby communities. Exposure to the general public may occur in accidental situations. TDA is not intended for the general use by the general public. TDA vapor or dust has a fish like odor which should not be used for early detection of any potential release. If you smell TDA, you are over the recommended exposure. TDA should only be handled by knowledgeable, well-trained personnel who thoroughly understand the hazards associated with the transportation, storage and use of the chemical.

Workplace exposure should be limited by the use of engineering controls. TDA vapors and dusts must be monitored and controlled below applicable regulatory limits. TDA should be processed within a closed

system. Worker exposure can potentially happen from leaks in piping system, during repair or replacement of the piping system or during removal of a sample for quality control purposes. Regulations involving hazardous chemicals are continually evolving and thus exposure guidelines are reviewed regularly and modified whenever new information dictates a change. It is important that all companies handling aniline are aware of the current legislative requirements. The guidelines established by OSHA, ACGIH, NIOSH and others, represent current thinking and are believed to be conservative and protective of occupational workers. There is not guarantee of absolute safety.

Date: November 15, 2008 Page: 3 of 5

Risk Management

The potential hazards associated with TDA can be avoided if workers are adequately instructed in supervised on the proper procedures of handling TDA. Personal protective equipment (PPE) should be selected based on the potential for exposure to particular chemical(s), and the unique properties of that chemical. In general, PPE is not an adequate substitute for appropriate workplace controls (such as ventilation), or other safe work practices. There may be situations when the only practical means of preventing employee exposure is through the effective use of PPE. When PPE is provided to employees, they must be trained in how, where, when, and why the equipment should be used. The facility must also have provisions for decontaminating and replacing such equipment as necessary.

Eye protection in the form of chemical splash goggles should be worn to prevent TDA from accidentally splashing in an employee's eye. Goggles should be non-vented, and designed specifically to protect against chemical splash. If an employee wears corrective lenses, chemical goggles should be worn over the lenses. Contact lenses are not recommended for use in areas where there is a potential for exposure to aniline. Corrosive vapors or dust can collect behind contact lenses and may cause severe damage to the eye and/or cause the contact lenses to adhere to the eyes.

Skin protection may be found in many forms. Hand protection such as chemical resistant gloves, protective arm sleeves, aprons, full body coveralls, boots, and head coverings are among the types available. Skin protection must be made of a material impervious to TDA. Personal protective equipment should be selected on the basis of potential exposure, e.g., gloves may be required for sample collection while full body clothing including gloves, boot covers, head covering may be necessary for spill clean-up. Skin protection for the purpose of preventing chemical exposure may be worn in conjunction with other types of PPE. For example, steel toe safety shoes may be required to prevent a person's foot from being crushed, but an additional boot cover may be required to prevent TDA permeation into the safety shoe. Skin protection PPE is available in a variety of sizes, and should be available in a size that fits the employee wearing it. Improperly sized PPE may compromise its effectiveness and create additional safety hazards. When skin protection PPE is used, there must be a means of cleaning or disposal/replacement of the PPE. Respiratory protection is available in two basic varieties, air purifying, and air supplied. In general, air purifying respirators provide less protection than air supplied respirators. Both types, however, have their particular advantages and limitations. The appropriate type of respirator must be selected to provide the appropriate level of protection for the anticipated degree of exposure to airborne aniline (vapor or mist). Detailed guidance for the selection of respiratory protection can be found in The American National Standards Institute Document Z88.2. Respiratory protective equipment should be approved by NIOSH. It must be carefully maintained, inspected, and cleaned. All employees required to wear respiratory protection must be medically cleared to do so (this ensures their physical capability to wear a respirator) and trained to use and care for the equipment. OSHA requirements for respiratory protection can be found in 29 CFR 1910.134.

Properly designed emergency showers and eyewash fountains should be placed in convenient locations wherever acrylic acid is used. All employees should know the location and operation of this equipment. All equipment must be frequently inspected to make sure they are in proper working condition.

Date: November 15, 2008 Page: 4 of 5

Federal/Science Findings (optional) U.S. Environmental Protection Agency – Integrated Risk Information System (IRIS) <http://www.epa.gov/ncea/iris/subst/0536.htm> U.S. Environmental Protection Agency <http://www.epa.gov/ttn/atw/hlthef/diamino.html> U.S Department of Labor – Occupational Safety and Health Administration (OSHA) http://www.osha.gov/dts/chemicalsampling/data/CH_272300.html American Conference of Governmental Industrial Hygienists (ACGIH) <http://www.acgih.org>

Contact Information**MSDS**<http://www.basf.com>http://worldaccount.basf.com/wa/PublicMSDS~en_US/Search**References**

IMPORTANT: While the data and information contained herein are presented in good faith and believed to be accurate, it is provided for your guidance only. No warranties of any kind, either express or implied, are made regarding the data or information provided. Further, it is expressly understood that the data and information furnished by BASF hereunder are given gratis and BASF assumes no obligation or liability for the data and information given, all such data and information being given and accepted at your risk.

Date: November 15, 2008 Page: 5 of 5

SAFETY DATA SHEET

North American Version

1. PRODUCT AND COMPANY IDENTIFICATION

1.1. Identification of the substance or preparation Product name : TFE (TRIFLUOROETHANOL)
Chemical Name : 2,2,2-Trifluoroethanol Synonyms : Trifluoroethanol Molecular formula : C₂H₃F₃O
Structural formula CF₃CH₂OH Molecular Weight : 100 g/mol

1.2. Use of the Substance/Preparation Recommended use : - Chemical intermediate
- Solvent **1.3. Company/Undertaking Identification**

Address : SOLVAY FLUORIDES, LLC 3333 RICHMOND AVENUE HOUSTON TX 77098-3099
United States

1.4. Emergency and contact telephone numbers Emergency telephone : 1 (800) 424-9300
CHEMTREC ® (USA & Canada)

Contact telephone number (product information):

2. HAZARDS IDENTIFICATION

01-800-00-214-00 (MEX. REPUBLIC)

: US: +1-800-765-8292 (Product information) US: +1-713-525-6500 (Product information)

2.1. Emergency Overview: NFPA : H= 3 F= 3 I= 0 S= None

HMIS : H= 3 F= 3 R= 0 PPE = Supplied by User; dependent on local conditions

General Information

Main effects

Appearance : liquid Colour : colourless Odour : characteristic

- Flammable - Harmful by inhalation, in contact with skin and if swallowed. - Irritating to skin. - Risk of

serious damage to eyes. - Harmful: danger of serious damage to health by prolonged exposure through

inhalation.

TFE (TRIFLUOROETHANOL) SAFETY DATA SHEET

- Possible risk of impaired fertility. - In case of decomposition, releases hydrogen fluoride.

2.2. Potential Health Effects:

Inhalation

- Irritating to mucous membranes - At high concentrations, cough and difficulty in breathing.

Eye contact

- Severe eye irritation, watering, redness and swelling of the eyelids. - Causes burns. - Risk of serious or permanent eye lesions.

Skin contact

- Dermal absorption possible - Irritation.

Ingestion

- Nausea, vomiting and diarrhea.

Other toxicity effects

- See section 11: Toxicological Information **2.3. Environmental Effects:**

- See section 12: Ecological Information

3. COMPOSITION/INFORMATION ON INGREDIENTS

2,2,2-Trifluoroethanol CAS-No. : 75-89-8 **Concentration** : > 99,5 %

4. FIRST AID MEASURES

4.1. Inhalation - Remove to fresh air.

- Oxygen or artificial respiration if needed. - Consult a physician.

4.2. Eye contact - Rinse immediately with plenty of water, also under the eyelids, for at least 15 minutes.

- In the case of difficulty of opening the lids, administer an analgesic eye wash (oxybuprocaine). - Consult with an ophthalmologist immediately in all cases.

4.3. Skin contact - Remove contaminated shoes, socks and clothing; wash the affected skin with running water.

- Wash contaminated clothing before re-use. - Consult a physician.

4.4. Ingestion - Consult a physician.

If victim is conscious:

- Clean mouth with water and drink afterwards plenty of water.

If victim is unconscious but breathing:

- Artificial respiration and/or oxygen may be necessary.

P 343 / Canada Issuing date 11.12.2008 / Report version 1.0 Copyright 2008, SOLVAY FLUORIDES, LLC A subsidiary of SOLVAY Chemicals All Rights Reserved
www.solvaychemicals.us

2/10

TFE (TRIFLUOROETHANOL) SAFETY DATA SHEET

5. FIRE-FIGHTING MEASURES

5.1. Suitable extinguishing media - powder

- Alcohol-resistant foam - Carbon dioxide (CO₂) - Water spray

5.2. Extinguishing media which shall not be used for safety reasons - None.

5.3. Special exposure hazards in a fire - Flammable.

- Hazardous decomposition products - Heating can release hazardous gases. - Gas/vapours are heavier than air and so may travel along the ground; remote ignition possible. - Vapours may form explosive mixtures with air.

5.4. Hazardous decomposition products - Hydrogen fluoride

- Fluorophosgene - Carbon monoxide

5.5. Special protective equipment for fire-fighters - Evacuate personnel to safe areas.

- Intervention only by capable personnel who are trained and aware of the hazards of the product. - In the event of fire, wear self-contained breathing apparatus. - Fire fighters must wear fire resistant personnel protective equipment. - When intervention in close proximity wear acid resistant over suit. - Protect intervention team with a water spray as they approach the fire. - Clean contaminated surface thoroughly.

5.6. Other information - If safe to do so, remove the exposed containers, or cool with large quantities of water.

- Approach from upwind. - Avoid propagating the fire when directing the extinguishing agent as a jet onto the surface of the burning

liquid. - After the fire, proceed rapidly to clean the surfaces exposed to the fumes in order to limit the damage to the

equipment. - As for any fire, ventilate and clean the rooms before re-entry.

6. ACCIDENTAL RELEASE MEASURES

6.1. Personal precautions - Refer to protective measures listed in sections 7 and 8.

- Prevent further leakage or spillage if safe to do so. - Keep away from open flames, hot surfaces and sources of ignition. - Keep away from incompatible products - Approach from upwind. - Suppress (knock down) gases/vapours/mists with a water spray jet. - Protect intervention team with water spray.

6.2. Environmental precautions - Do not flush into surface water or sanitary sewer system.

- If the product contaminates rivers and lakes or drains inform respective authorities.

P 343 / Canada Issuing date 11.12.2008 / Report version 1.0 Copyright 2008, SOLVAY FLUORIDES, LLC A subsidiary of SOLVAY Chemicals All Rights Reserved
www.solvaychemicals.us

3/10

TFE (TRIFLUOROETHANOL) SAFETY DATA SHEET

6.3. Methods for cleaning up - If possible, dam large quantities of liquid with sand or earth.

- Prevent product from entering drains. - Soak up with inert absorbent material (e.g. sand, silica gel, acid binder, universal binder, sawdust). - Place everything into a closed, labelled container compatible with the product. - Store in a place accessible by authorized persons only. - Treat recovered material as described in the section "Disposal considerations". - Flush with plenty of water.

7. HANDLING AND STORAGE

7.1. Handling - Used in closed system

- Handle small quantities under a lab hood. - Use only in well-ventilated areas. - No sparking tools should be used. - Prevent any product decomposition from contacting hot spots. - Use only equipment and materials which are compatible with the product. - Keep away from heat and sources of ignition. - Keep away from incompatible products

7.2. Storage - Keep in a cool, well-ventilated place.

- Keep away from heat and sources of ignition. - Keep away from incompatible products - Keep under inert gas. - Keep in a banded area. - Information about special precautions needed for bulk handling is available on request.

7.3. Packaging material - Steel drum

- Stainless steel **7.4. Other information**

- No open flames or sparks, no smoking. - Provide electrical equipment safe for hazardous locations. - Ensure all equipment is electrically grounded before beginning transfer operations. - Take measures to prevent the build up of electrostatic charge. - Warn people about the dangers of the product. - Refer to protective measures listed in sections 7 and 8.

8. EXPOSURE CONTROLS/PERSONAL PROTECTION

8.1. Exposure Limit Values 2,2,2-Trifluoroethanol

- US. ACGIH Threshold Limit Values Remarks: none established

8.2. Engineering controls - Ensure adequate ventilation.

- Provide local ventilation appropriate to the product decomposition risk (see section 10). - Apply technical measures to comply with the occupational exposure limits.

P 343 / Canada Issuing date 11.12.2008 / Report version 1.0 Copyright 2008, SOLVAY FLUORIDES, LLC A subsidiary of SOLVAY Chemicals All Rights Reserved
www.solvaychemicals.us

4/10

TFE (TRIFLUOROETHANOL) SAFETY DATA SHEET

8.3. Personal protective equipment

8.3.1. Respiratory protection

- Self-contained breathing apparatus in medium confinement/insufficient oxygen/in case of large uncontrolled emissions/in all circumstances when the mask and cartridge do not give adequate protection.

- Use only respiratory protection that conforms to international/ national standards. - Use NIOSH approved respiratory protection.

8.3.2. Hand protection

- Wear suitable gloves. - Recommended materials: Neoprene, rubber

8.3.3. Eye protection

- Chemical resistant goggles must be worn.

8.3.4. Skin and body protection

- Protective suit - Apron/boots of neoprene if risk of splashing.

8.3.5. Hygiene measures

- Shower and eye wash stations. - Handle in accordance with good industrial hygiene and safety practice.

9. PHYSICAL AND CHEMICAL PROPERTIES**9.1. General Information Appearance** : liquid**Colour** : colourless **Odour** : characteristic**9.2. Important health safety and environmental information pH** : *Remarks*: neutral**Boiling point/boiling range** : 73,6 °C (164,5 °F) **Flash point** : 33 °C (91 °F)*Remarks*: Flammable. **Flammability** : *Upper explosion limit* :P 343 / Canada Issuing date 11.12.2008 / Report version 1.0 Copyright 2008, SOLVAY FLUORIDES, LLC A subsidiary of SOLVAY Chemicals All Rights Reserved
www.solvaychemicals.us28,8 %(V) *Lower explosion limit* : 8,4 %(V)**Explosive properties** : **Vapour pressure** : 52 mbar*Temperature*: 20 °C (68 °F) **Relative density / Density** : = 1,38 **Solubility** : Water*Remarks*: completely miscible **Partition coefficient**:**n-octanol/water** : *log Pow* :

= 0,652

Method: calculated value **Viscosity** : Viscosity

1,24 mPa.s

5/10

TFE (TRIFLUOROETHANOL) SAFETY DATA SHEET*Temperature*: 38 °C (100 °F) **Vapour density** : *Remarks*: no data available**9.3. Other data****Melting point/range** : -43,5 °C (-46,3 °F) **Decomposition****temperature** : 315 °C (599 °F)**10. STABILITY AND REACTIVITY****10.1. Stability** - Stable under recommended storage conditions.**10.2. Conditions to avoid** - Heat.

- Naked flames, sparks. - Exposure to moisture. - Keep at temperature not exceeding: 315 °C (599 °F)

10.3. Materials to avoid - Oxidizing agents- Strong bases **10.4. Hazardous decomposition products**

- Hydrogen fluoride - Fluorophosgene - Carbon monoxide

11. TOXICOLOGICAL INFORMATION**Toxicological data****Acute oral toxicity**

- LD50, rat, 210 - 590 mg/kg

Acute inhalation toxicity- LC50, 6 h, rat, 1.922 - 2.618 mg/m³**Acute dermal irritation/corrosion**

- LD50, rabbit, 1.680 mg/kg

Skin irritation

- rabbit, irritant (skin)

Eye irritation

- rabbit, Risk of serious damage to eyes.

Chronic toxicity

- Oral, after a single exposure, rat, Target Organs: gastro-intestinal system, testes, hematology system, observed effect

- Inhalation, Repeated exposure, rat, Target Organs: testes, NOEL: 50 ppm, observed effect

Genetic toxicity in vitro

- in vitro, Animal testing did not show any mutagenic effects.

Toxicity to reproduction

- Effect on fertility

P 343 / Canada Issuing date 11.12.2008 / Report version 1.0 Copyright 2008, SOLVAY FLUORIDES, LLC A subsidiary of SOLVAY Chemicals All Rights Reserved
www.solvaychemicals.us

6/10

TFE (TRIFLUOROETHANOL) SAFETY DATA SHEET

Remarks

- Harmful by inhalation, in contact with skin and if swallowed. - corrosive effects - Effects on fertility

12. ECOLOGICAL INFORMATION**12.1. Ecotoxicity effects****Acute toxicity**

- Fishes, Pimephales promelas, LC50, 96 h, 119 mg/l

Chronic toxicity

- Remarks: no data available **12.2. Mobility**

- Water/soil Remarks: considerable solubility and mobility

- Soil/sediments Remarks: non-significant adsorption

12.3. Persistence and degradability**Abiotic degradation**

- Result: no data available

Biodegradation

- Remarks: no data available **12.4. Bioaccumulative potential**

- Bioconcentration: log Pow = 0,652 Result: Bioaccumulation is unlikely. Remarks: calculated value

12.5. Other adverse effects - no data available

12.6. Remarks - Hazard for the environment is limited due to product properties:

- . low toxicity for aquatic organisms. - . high mobility. - Does not bioaccumulate.

13. DISPOSAL CONSIDERATIONS

13.1. Waste from residues / unused products - In accordance with local and national regulations.

- Refer to manufacturer/supplier for information on recovery/recycling. - Or - Must be incinerated in a suitable incineration plant holding a permit delivered by the competent authorities. - The incinerator must be equipped with a system for the neutralisation or recovery of HF.

13.2. Packaging treatment - To avoid treatments, as far as possible, use dedicated containers.

13.3. RCRA Hazardous Waste - Listed RCRA Hazardous Waste (40 CFR 302) - No

- Unlisted RCRA Hazardous Waste (40 CFR 302) - Yes - D001 (ignitable waste)

P 343 / Canada Issuing date 11.12.2008 / Report version 1.0 Copyright 2008, SOLVAY FLUORIDES, LLC A subsidiary of SOLVAY Chemicals All Rights Reserved
www.solvaychemicals.us

7/10

TFE (TRIFLUOROETHANOL) SAFETY DATA SHEET

14. TRANSPORT INFORMATION

UN-Number 1987 UN-Number 1987

IATA-DGR

Class 3 Packing group III ICAO-Labels FLAMMABLE LIQUID

Proper shipping name: ALCOHOLS, N.O.S. (TRIFLUOROETHANOL)

IMDG Class 3

Packing group III ICAO-Labels Flammable Liquids HI/UN No. 1987

Proper shipping name: ALCOHOLS, N.O.S. (TRIFLUOROETHANOL)

U.S. Dept of Transportation Class (Subsidiary) 3

Packing group III Label (Subsidiary) Flammable liquid Marine pollutant: no Emergency info: ERG: 127

Proper shipping name: ALCOHOLS, N.O.S. (TRIFLUOROETHANOL)

Canada (TDG) Class (Subsidiary) 3

Packing group III Label (Subsidiary) Flammable Liquid Marine pollutant: no Emergency info: ERG: 127

Proper shipping name: ALCOHOLS, N.O.S. (TRIFLUOROETHANOL)

- DOT Packing Group: III

15. REGULATORY INFORMATION**15.1. Other regulations**

US. EPA Emergency Planning and Community Right-To-Know Act (EPCRA) SARA Title III Section 302 Extremely Hazardous Substance (40 CFR 355, Appendix A)

- not regulated. **SARA Hazard Designation (SARA 311/312)**

- Acute Health Hazard: Yes.

P 343 / Canada Issuing date 11.12.2008 / Report version 1.0 Copyright 2008, SOLVAY FLUORIDES, LLC A subsidiary of SOLVAY Chemicals All Rights Reserved
www.solvaychemicals.us

8/10

TFE (TRIFLUOROETHANOL) SAFETY DATA SHEET

- Fire Hazard: Yes. **US. EPA Emergency Planning and Community Right-To-Know Act (EPCRA) SARA Title III Section 313 Toxic**

Chemicals (40 CFR 372.65) - Supplier Notification Required - not regulated.

US. EPA CERCLA Hazardous Substances (40 CFR 302) - not regulated.

US. New Jersey Worker and Community Right-to-Know Act (New Jersey Statute Annotated Section 34:5A-5) - not regulated.

US. Pennsylvania Worker and Community Right-to-Know Law (34 Pa. Code Chap. 301-323) - not regulated.

US. California Safe Drinking Water & Toxic Enforcement Act (Proposition 65) - not regulated.

15.2. Classification and labelling

Canada. Canadian Environmental Protection Act (CEPA). WHMIS Ingredient Disclosure List (Can. Gaz., Part II, Vol. 122, No. 2)

- B2 Flammable Liquid - D2B Toxic Material Causing Other Toxic Effects

Remarks: This product has been classified in accordance with the hazard criteria of the Controlled Products Regulations and the MSDS contains all the information required by the Controlled Products Regulations.

EC Label - Classification and labelling according to Directive 67/548/EEC.

Symbol(s) Xn Harmful R-phrase(s) R10 Flammable.

R20/21/22 Harmful by inhalation, in contact with skin and if swallowed. R38 Irritating to skin. R41 Risk of serious damage to eyes. R48/20 Harmful: danger of serious damage to health by prolonged exposure through inhalation. R62 Possible risk of impaired fertility.

S-phrase(s) S21 When using do not smoke. S37/39 Wear suitable gloves and eye/face protection.

S26 In case of contact with eyes, rinse immediately with plenty of water and seek medical advice.

16. OTHER INFORMATION

Ratings : NFPA (National Fire Protection Association)

Health = 3 Flammability = 3 Instability = 0 Special =None **HMIS (Hazardous Material Information System)**

Health = 3 Fire = 3 Reactivity = 0 PPE : Supplied by User; dependent on local conditions

P 343 / Canada Issuing date 11.12.2008 / Report version 1.0 Copyright 2008, SOLVAY FLUORIDES, LLC A subsidiary of SOLVAY Chemicals All Rights Reserved
www.solvaychemicals.us

9/10

TFE (TRIFLUOROETHANOL) SAFETY DATA SHEET

Further information

- Update This data sheet contains changes from the previous version in section(s): 8.1

- Distribute new edition to clients

Material Safety Data Sheets contain country specific regulatory information; therefore, the MSDS's provided are for use only by customers of the company mentioned in section 1 in North America. If you are located in a country other than Canada, Mexico or the United States, please contact the Solvay

Group company in your country for MSDS information applicable to your location. The previous information is based upon our current knowledge and experience of our product and is not exhaustive. It applies to the product as defined by the specifications. In case of combinations or mixtures, one must confirm that no new hazards are likely to exist. In any case, the user is not exempt from observing all legal, administrative and regulatory procedures relating to the product, personal hygiene, and integrity of the work environment. (Unless noted to the contrary, the technical information applies only to pure product). To our actual knowledge, the information contained herein is accurate as of the date of this document. However, neither the company mentioned in section 1 nor any of its affiliates makes any warranty, express or implied, including merchantability or fitness for use, or accepts any liability in connection with this information or its use. This information is for use by technically skilled persons at their own discretion and risk and does not relate to the use of this product in combination with any other substance or any other process. This is not a license under any patent or other proprietary right. The user alone must finally determine suitability of any information or material for any contemplated use, the manner of use and whether any patents are infringed. This information gives typical properties only and is not to be used for specification purposes. The company mentioned in section 1 reserves the right to make additions, deletions or modifications to the information at any time without prior notification. Trademarks and/or other products of the company mentioned in section 1 referenced herein are either trademarks or registered trademarks of the company mentioned in section 1 or its affiliates, unless otherwise indicated. This product has been classified in accordance with the hazard criteria of the Controlled Products Regulations and the MSDS contains all the information required by the Controlled Products Regulations. Copyright 2008, Company mentioned in Section 1. All Rights Reserved.

P 343 / Canada Issuing date 11.12.2008 / Report version 1.0 Copyright 2008, SOLVAY FLUORIDES, LLC A subsidiary of SOLVAY Chemicals All Rights Reserved
www.solvaychemicals.us

10/10

MATERIAL SAFETY DATA SHEET

PRODUCT NAME: PHOSGENE

MSDS: G-67

Revised: 6/7/96 Page 1 of 7

1. Chemical Product and Company Identification

BOC Gases,

Division of

The BOC Group, Inc.

575 Mountain Avenue

Murray Hill, NJ 07974

TELEPHONE NUMBER: (908) 464-8100

BOC Gases

Division of

BOC Canada Limited

5975 Falbourne Street, Unit 2

Mississauga, Ontario L5R 3W6

TELEPHONE NUMBER: (905) 501-1700

24-HOUR EMERGENCY TELEPHONE NUMBER:

CHEMTREC (800) 424-9300

24-HOUR EMERGENCY TELEPHONE NUMBER:

(905) 501-0802

EMERGENCY RESPONSE PLAN NO: 20101

PRODUCT NAME: PHOSGENE

CHEMICAL NAME: Phosgene

COMMON NAMES/SYNONYMS: Carbon Oxychloride; Carbonyl Chloride; Carbonyl Dichloride;

Diphosgene

TDG (Canada) CLASSIFICATION: 2.3 (8)

WHMIS CLASSIFICATION: A, E, F, D1A

PREPARED BY: Loss Control (908)464-8100/(905)501-1700

PREPARATION DATE: 6/1/95

REVIEW DATES: 6/7/96

2. Composition, Information on Ingredients

INGREDIENT % VOLUME PEL-OSHA¹ TLV-ACGIH² LD₅₀ or LC₅₀

Route/Species

Phosgene

FORMULA: CCl₂O

CAS: 75-44-5

RTECS #: SY5600000

100.0 0.1 ppm TWA 0.1 ppm TWA LC₅₀

800 ppm

(human)

¹ As stated in 29 CFR 1910, Subpart Z (revised July 1, 1993)

² As stated in the ACGIH 1994-95 Threshold Limit Values for Chemical Substances and Physical Agents

3. Hazards Identification+

EMERGENCY OVERVIEW

Corrosive to exposed tissues. Inhalation of vapors may result in pulmonary edema and chemical pneumonitis. Nonflammable. Reacts violently and decomposes to toxic compounds, including chlorine, on contact with moisture.

ROUTE OF ENTRY:

Skin Contact

Yes

Skin Absorption

No

Eye Contact

Yes

Inhalation

Yes

Ingestion

No

PRODUCT NAME: PHOSGENE

MSDS: G-67

Revised: 6/7/96 Page 2 of 7

HEALTH EFFECTS:

Exposure Limits

Yes

Irritant

Yes

Sensitization

No

Teratogen

No

Reproductive Hazard

No

Mutagen

No

Synergistic Effects

None Reported

Carcinogenicity: -- NTP: No ARC: No OSHA: No

EYE EFFECTS:

None known.

SKIN EFFECTS:

None known.

INGESTION EFFECTS:

None known.

INHALATION EFFECTS:

Immediate symptoms from inhalation are choking, coughing, tightness of the chest, catching of the breath, lacrimation, difficulty in and painful breathing and eventual cyanosis. Serious symptoms are pulmonary edema and asphyxiation which may not be manifested for several hours after overexposure. Long lasting (several months) symptoms may be coughing, bloody sputum and general malaise.

NFPA HAZARD CODES HMIS HAZARD CODES RATINGS SYSTEM

Health: 4 Health: 4 0 = No Hazard

Flammability: 0 Flammability: 0 1 = Slight Hazard

Reactivity: 1 Reactivity: 1 2 = Moderate Hazard

3 = Serious Hazard

4 = Severe Hazard

4. First Aid Measures**EYES:**

None required.

SKIN:

None required.

INGESTION:

None required.

PRODUCT NAME: PHOSGENE

MSDS: G-67

Revised: 6/7/96 Page 3 of 7

INHALATION:

Conscious persons should be assisted to an uncontaminated area and inhale fresh air. Unconscious persons should be moved to an uncontaminated area, and given artificial resuscitation and supplemental oxygen. Keep the victim warm and quiet. Assure that mucous does not obstruct the airway by positional drainage. Delayed pulmonary edema may occur. Keep patient under medical observation for at least 48 hours. Treatment should be symptomatic and supportive.

PROMPT MEDICAL ATTENTION IS MANDATORY IN ALL CASES OF OVEREXPOSURE TO PHOSGENE. RESCUE PERSONNEL SHOULD BE EQUIPPED WITH SELF-CONTAINED BREATHING APPARATUS.

5. Fire Fighting Measures

Conditions of Flammability: Nonflammable

Flash point:

None

Method:

Not Applicable

Autoignition

Temperature: None

LEL(%): None UEL(%): None

Hazardous combustion products: None

Sensitivity to mechanical shock: None

Sensitivity to static discharge: None

FIRE AND EXPLOSION HAZARDS:

Nonflammable.

FIRE FIGHTING INSTRUCTIONS:

NONE. Material is not flammable. See spill and leaks information for protective equipment when fighting a spill.

6. Accidental Release Measures

Evacuate all personnel from affected area. Use appropriate protective equipment. If leak is in user's equipment, be certain to purge piping with inert gas prior to attempting repairs. If leak is in container or container valve, contact the appropriate emergency telephone number listed in Section 1 or call your closest BOC location.

7. Handling and Storage

Moist phosgene is corrosive to most metals. Hastelloy A or B as well as tantalum, platinum and gold show good corrosive resistance to moist phosgene.

Protect cylinders from physical damage. Store in cool, dry, well-ventilated area away from heavily trafficked

areas and emergency exits. Do not allow the temperature where cylinders are stored to exceed 130°F (54°C). Cylinders should be stored upright and firmly secured to prevent falling or being knocked over. Full and empty cylinders should be segregated. Use a "first in-first out" inventory system to prevent full cylinders being stored for excessive periods of time.

PRODUCT NAME: PHOSGENE

MSDS: G-67

Revised: 6/7/96 Page 4 of 7

Use only in well-ventilated areas. Valve protection caps and valve outlet threaded plugs must remain in place unless container is secured with valve outlet piped to use point. Do not drag, slide or roll cylinders. Use a suitable hand truck for cylinder movement. Use a pressure reducing regulator when connecting cylinder to lower pressure (less than 75 psig) piping or systems. Do not heat cylinder by any means to increase the discharge rate of product from the cylinder. Use a check valve or trap in the discharge line to prevent hazardous back flow into the cylinder.

For additional storage and handling recommendations, consult Compressed Gas Association's Pamphlet P-1. Never carry a compressed gas cylinder or a container of a gas in cryogenic liquid form in an enclosed space such as a car trunk, van or station wagon. A leak can result in a fire, explosion, asphyxiation or a toxic exposure.

8. Exposure Controls, Personal Protection

EXPOSURE LIMITS¹:

INGREDIENT % VOLUME PEL-OSHA² TLV-ACGIH³ LD₅₀ or LC₅₀

Route/Species

Phosgene

FORMULA: CCl₂O

CAS: 75-44-5

RTECS #: SY5600000

100.0 0.1 ppm TWA 0.1 ppm TWA LC₅₀

800 ppm

(human)

¹ Refer to individual state of provincial regulations, as applicable, for limits which may be more stringent than those listed here.

² As stated in 29 CFR 1910, Subpart Z (revised July 1, 1993)

³ As stated in the ACGIH 1994-1995 Threshold Limit Values for Chemical Substances and Physical Agents.

IDLH: 2 ppm

ENGINEERING CONTROLS:

Use a laboratory hood with forced ventilation for handling small quantities. Use local exhaust to prevent accumulation above the exposure limits.

EYE/FACE PROTECTION:

Gas tight chemical goggles or full-face piece respirator.

SKIN PROTECTION:

Rubber or Teflon® protective gloves.

RESPIRATORY PROTECTION:

Positive pressure air line with full-face mask and escape bottle or self-contained breathing apparatus should be available for emergency use and routine use when exposures are above set limits.

OTHER/GENERAL PROTECTION:

Safety shoes, safety shower, eyewash "fountain".

PRODUCT NAME: PHOSGENE

MSDS: G-67

Revised: 6/7/96 Page 5 of 7

9. Physical and Chemical Properties

PARAMETER VALUE UNITS

Physical state (gas, liquid, solid) : Gas

Vapor pressure : 22.6 psia

Vapor density (Air = 1) : 3.41

Evaporation point : Not Available

Boiling point : 45.6

: 7.55

°F

°C

Freezing point : -198

: -127

°F

°C

pH : Not Available

Specific gravity : Not Available

Oil/water partition coefficient : Not Available

Solubility (H₂O) : Decomposes

Odor threshold : Not Available

Odor and appearance : Colorless gas with sweet odor in low concentrations, becoming suffocating in high concentrations

10. Stability and Reactivity

STABILITY:

Stable at temperatures below 572°F (300°C).

INCOMPATIBLE MATERIALS:

May react violently with water, ammonia, primary amines.

HAZARDOUS DECOMPOSITION PRODUCTS:

Hydrochloric acid and carbon dioxide. Carbon monoxide, chlorine.

HAZARDOUS POLYMERIZATION:

Will not occur.

11. Toxicological Information

No chronic effects data unrelated to phosgene's corrosivity given in the Registry of Toxic Effects of Chemical Substances (RTECS) or Sax, Dangerous Properties of Industrial Materials, 7th ed.

12. Ecological Information

No data given.

13. Disposal Considerations

Do not attempt to dispose of residual waste or unused quantities. Return in the shipping container PROPERLY LABELED, WITH ANY VALVE OUTLET PLUGS OR CAPS SECURED AND VALVE PROTECTION CAP IN PLACE to BOC Gases or authorized distributor for proper disposal.

PRODUCT NAME: PHOSGENE

MSDS: G-67

Revised: 6/7/96 Page 6 of 7

14. Transport Information

PARAMETER United States DOT Canada TDG

PROPER SHIPPING NAME: Phosgene Phosgene

HAZARD CLASS: 2.3 2.3 (8)

IDENTIFICATION NUMBER: UN 1076 UN 1076

SHIPPING LABEL: POISON GAS, CORROSIVE POISON GAS, CORROSIVE

Additional Marking Requirement: "Inhalation Hazard"

If net weight of product > 10 pounds, the container must be also marked with the letters "RQ".

Additional Shipping Paper Description Requirement: "Poison Inhalation Hazard, Zone A"

If net weight of product > 10 pounds, the shipping papers must be also marked with the letters "RQ".

15. Regulatory Information

Phosgene is listed under the accident prevention provisions of section 112(r) of the Clean Air Act (CAA) with a threshold quantity (TQ) of 500 pounds.

SARA TITLE III NOTIFICATIONS AND INFORMATION

Phosgene is listed as an extremely hazardous substance (EHS) subject to state and local reporting under Section 304 of SARA Title III (EPCRA).

The presence of phosgene in quantities in excess of the threshold planning quantity (TPQ) of 10 pounds requires certain emergency planning activities to be conducted.

Releases of phosgene in quantities equal to or greater than the reportable quantity (RQ) of 10 pounds are subject to reporting to the National Response Center under CERCLA, Section 304 SARA Title III.

SARA TITLE III - HAZARD CLASSES:

Acute Health Hazard

Chronic Health Hazard
Sudden Release of Pressure Hazard
Reactivity Hazard
Fire Hazard

SARA TITLE III - SECTION 313 SUPPLIER NOTIFICATION:

This product contains the following toxic chemicals subject to the reporting requirements of section 313 of the Emergency Planning and Community Right-To-Know Act (EPCRA) of 1986 and of 40 CFR 372:

CAS NUMBER INGREDIENT NAME PERCENT BY VOLUME

75-44-5 PHOSGENE ~ 100.0

This information must be included on all MSDSs that are copied and distributed for this material.

16. Other Information

Compressed gas cylinders shall not be refilled without the express written permission of the owner. Shipment of a compressed gas cylinder which has not been filled by the owner or with his/her (written) consent is a violation of transportation regulations.

PRODUCT NAME: PHOSGENE

MSDS: G-67

Revised: 6/7/96 Page 7 of 7

DISCLAIMER OF EXPRESSED AND IMPLIED WARRANTIES:

Although reasonable care has been taken in the preparation of this document, we extend no warranties and make no representations as to the accuracy or completeness of the information contained herein, and assume no responsibility regarding the suitability of this information for the user's intended purposes or for the consequences of its use. Each individual should make a determination as to the suitability of the information for their particular purpose(s).