



February 2007

Work 2006/2007

Follow this and additional works at: http://repository.upenn.edu/arch_work

Recommended Citation

"*Work 2006/2007*" (2007). *Work (Architecture)*. 2.
http://repository.upenn.edu/arch_work/2

The work shown here is solely available for viewing and not for republishing or to be rebroadcast in any form. If you wish to republish any of this work, please contact the Department office.

This paper is posted at ScholarlyCommons. http://repository.upenn.edu/arch_work/2
For more information, please contact libraryrepository@pobox.upenn.edu.

Work 2006/2007

Abstract

WORK is an annual publication of the Department of Architecture that documents student work in design studios and courses in the Master of Architecture and Post-Professional programs, as well as events, faculty news and student awards. It also includes abstracts of PhD dissertations defended that year. It provides an opportunity to explore the creative work of our students and is a permanent record of work in the Department.

Comments

The work shown here is solely available for viewing and not for republishing or to be rebroadcast in any form. If you wish to republish any of this work, please contact the Department office.

WORK 2006/2007

**UNIVERSITY OF PENNSYLVANIA
SCHOOL OF DESIGN
DEPARTMENT OF ARCHITECTURE**

**Detlef Mertins, Chair
William Braham, Associate Department Chair
Winka Dubbeldam, Director, Post-Professional Program
David Leatherbarrow, Chair, Graduate Group in Architecture**

```
xt f1 ietsu (* ~ txt) | >
IF1 SENTIM mystr (ah)
Msg Bk in read sum for
myString = my:
Exitn = sub ITy:
Eads e f myArray = myA)
' ' Set Redim arr Poi:
Set hold the curve
my file = fso.c
Dim myString myAr:
' ' read info str r er
myString = my file RE
myArray nts Spnt (myA
ReDim myArray (0)
dit the Gen (Int (myEArsr
```

TABLE OF CONTENTS

Introduction Detlef Mertins

Studios 501
502
601
602
701
702
703
704
706

Dissertations Zhongjie Lin / Hassan Radoine

Courses Required

511 History and Theory I
512 History and Theory II
521 Visual Studies I
522 Visual Studies II
531 Construction I
532 Construction II
533 Environmental Systems I
534 Environmental Systems II
535 Structures I
536 Structures II
611 History and Theory III
621 Visual Studies III
631 Technology Case Studies I
632 Deployable Structures
632 Simulation and Design
632 Surfaces/Effects
632 Finding Sustainable Form
632 High Performance Materials and Systems
638 Building Acoustics
638 Building Skins
638 Building Systems
638 Biotechniques
638 Component Based Architecture
671 Professional Practice I
672 Professional Practice II
772 Professional Practice III
811 Theory I
812 Theory II

Courses Elective

711 Informal Cities
711 Mies van der Rohe
712 The Philosophy of Materials & Structures
712 Architecture and Race
712 Contemporary Japanese Architecture
717 Self-Organization & Dynamics of Cities
718 Japanese Architecture
719 Archigram and its Legacy: London, a Technopia
722 Between Line and Shadow
726 Furniture Design
732 Building Systems Integration
734 Architecture & Ecology
736 Traversing Textile Hierarchies
738 Ecologies: Organisms and Environments
739 Building Pathology
741 Computational Design in Architecture
741 Generative Models
743 Form and Algorithm
744 Digital Fabrication
752 Case Studies in Urban Design
762 Design and Development
765 Project Management
768 Real Estate Development
773 Local Knowledge: Architectural Culture, Indigenous Buildings and Settlements
780 Architecture in the Schools

Events
News

INTRODUCTION: OPEN AND EXPERIMENTAL

Schools are infrastructure for people to learn, teach, and research—for individuals to discover a field, pursue their way in it and make a contribution. To nurture creativity among students and faculty alike, such a support system requires more than academic programs, facilities, and financial resources. These are, of course, vital constituents, but the infrastructure would be incomplete without those who occupy these spaces and deploy these resources in the spirit of an academic community. An academic community is a special kind of infrastructure—a social experiment that is open, generous but loose, not as unified as the traditional connotations of “community” suggest. The looseness of connections seem crucial for the chemistry that makes a school productive. Great things are possible when people feel supported in exploring an idea, stretching their limits, and taking risks in the company of others doing the same, all the while remaining curious about other ways, eager for responses and discussions and engage outside their own space.

2006–2007 was a year when a community in this sense—a community of experimentation—seemed palpable in our midst. A prospective student at one of our Open Houses told me that of all the schools she had visited, our faculty clearly enjoyed teaching the most. What a compliment! Students too were unabashed in the pleasure they took in their effort. Of course, design is itself addictive for the extraordinary pleasures derived from indulging the imagination, thinking through making, and expanding aptitudes for action. But it is infinitely enriched in a social milieu that understands the anxieties of uncertain trajectories, and that shares the exhilaration of discovering what one has done only after having done it. The spirit of community that we experienced was an unintended effect of a multitude of actions in a seemingly unorganized social assemblage.

At the outset of the year, several independent events seemed to signal this sense of community. The exhibition, *H_edge*, at Artists Space in New York, brought the spotlight not only on Cecil Balmond’s Advanced Geometry Unit at Arup but on an important part of the shared terrain evolving in our program. Jenny Sabin contributed to the design and a team of Penn students prepared the installation—a spectacular demonstration of the capacity of mathematics and physics to unleash latent capacities in matter. More modest but equally explosive, was the first student work from Rhett Russo’s new iteration of our introductory design studio, animate structures that then populated the studio for the rest of the semester (and the bottom of this page). Also still in September, Peter Eisenman and Laurie Olin delighted everyone in a very personal and free-wheeling conversation about their many collaborations, on the occasion of their installation at the ICA, *Fertilizers*. They showed how much pleasure can be had when designers connect with one another over a long time, across disciplines and with ideas, sensibilities and values that diverge as often as they converge.



Hyunjoon Cho, Hyunao Kim, and Wei Wong

This spring, we introduced an integrative design studio, coordinated by Ferda Kolatan, as a new locus of interconnectivity, in which second-year students worked, often in teams and directly with consultants, to tap innovations in engineering, material science, and fabrication that are redefining the horizon of architectural practice today. Of the many other stories of connections that could be told, allow me to mention just a few. The first concerns the apparently spontaneous eruption of natural models from biology and ecology throughout so many of our studios, courses and events; the second is the emergence of critical mass around political issues. Fostered over the past few years by many of our faculty, the new intensity of work with natural models coincided with a broader engagement with environmental performance and ecosystems approaches to building. Bill Braham organized our courses in ecological architecture into a new certificate, Balmond's Nonlinear Systems Organization (NSO) focused on generative models from biology, and a host of new relations emerged with Peter Lloyd Jones and Peter Davies of Penn's Institute for Medicine and Engineering (IME).

Our studios continued to address architecture's role in political spectacle, community development and redefining institutions. In theory courses, David Leatherbarrow dug deep into issues of ethics and Manuel DeLanda rethought the philosophy of society through the dynamics of complexity and self-organization. Daniela Fabricius taught on informal cities and economies in Latin America and Charles Davis on architecture and race; a group of students self-organized to help rebuild homes in New Orleans; a School-wide conference grappled with diversity in the design professions (*Unspoken Borders*); and we collaborated with the Slought Foundation in West Philadelphia and Eyal Weizmann's Goldsmiths Centre for Architecture Research in London to host a conference on architecture and geopolitics (*Evasions of Power*). Organized by Srđjan Jovanovic Weiss, Aaron Levy and Kathrine Carl, *Evasions* involved some thirty speakers whose work demonstrated how inexorably politicized the production of space is, at every scale and in every corner of an increasingly interconnected yet fragmented world.

One effect of such connections is to suggest that even more are possible across fields that may seem disconnected but can potentially expand the capabilities of our profession and the disposition of our species. They are crucial as we strive to inhabit better a world that we help shape, but don't control and, dare I add: don't want to control. Articulating alternatives to the paradigm of control is, in fact, an urgent task. Perhaps our modest success in fostering a supportive milieu for experimentation within our own social assemblage holds lessons for this larger task.

Detlef Mertins, Chair
July 2007



Measurement has always been fundamental to architecture and yet despite its long history the use of mathematical methods has remained rather simple. This studio introduced students to the fundamental processes of design; scale, measure, materiality, computation and fabrication. What are the opportunities of approaching design in terms of the mathematical relationships between things, rather than the pursuit of a single form? How do we define useful parameters in the design process, and how can design benefit from the deployment of variables and attributes versus those prescribed by function alone? How might a systems-based approach initiate a better understanding of complex behaviors and allow for a higher degree of spatial and formal variation?

The semester focused on understanding and developing organizational strategies that are unique to natural systems and computation. Each critic investigated how 'natural' phenomena occur in a variety of disciplines; Biology, Material Science, Sociology, Mathematics, and Computation. Critical models were proposed in response to questions concerning ontology, which has traditionally relied on causal explanations and linear thinking as a way of defining phenomena in the sciences. The students were asked to formulate a parametric approach; one that sought to isolate phenomena into levels of interrelatedness by defining what is irreducible for any given level. Scripting, manual drawing and digital modeling were all vital tools for formulating and executing these inquiries.

The semester consisted of three projects. The first project challenged the students to develop novel assemblies with playing cards. Each critic developed techniques for cataloging 'part to whole' relationships through diagramming, graphic analysis, mathematical expressions, and manual algorithms. The second project continued with this research in the design of an exhibition system for Civil War Artifacts at The Armory of The First Troop in Philadelphia. Students were asked to curate and design an exhibition system for a variety of artifacts that ranged in scale, from a medallion to a canon. The studios reassessed the artifacts according to a variety of anthropological parameters; dimensionality, cultural significance, construction and position within the military hierarchy. The final project investigated ecotourism and architecture in the Galapagos. The challenge was to design an Eco-Pavilion that combined the services of a bicycle hub and cafe with a visitor center. Located along the ocean front, in a shallow tidal basin, proposals negotiated the interior demands of the visitor center, the complexity of an operable envelope, and the challenges associated with building in a tidal plain along the cities edge.



LEFT: HYUN JOON CHO, WEI WANG, SOO KIM (WITH JONAS COERSMEIER): Our project started from investigating and extracting the logic behind the formation of lizard skin, and then translated this principle derived from a biological model to an architectural design strategy, which is a module based and parametrically organized system. The number of modules (folded card) increases by one in every iteration, and then neighboring iteration are connected on both ends in parametrically increased position, until the system reaches its own limitation in terms of space capacity.

MIDDEL: JOHNNY LIN AND PABLO KOHAN (WITH RHETT RUSSO)

BELOW: BRIAN KELLEY (WITH JENNY SABIN): The model is derived from analyzing rhizomes which grow through an underground non-hierarchical network. The cards are linked to form chains which connect at various nodes, mimicking the rhizome's network of roots, shoots, and nodes.



JAE YOUNG LEE, ERICA SWESEY: The card structure was generated by a rigorous set of local and global rules that were extracted from the natural system of skeletal muscle cell myofilaments. The relationships took form as a complex nodal system with forward and feedback connections. Unpredictably, the strength of the rubber bands was highly influential, causing torquing and central pulling forces, also characteristic of myofilaments.

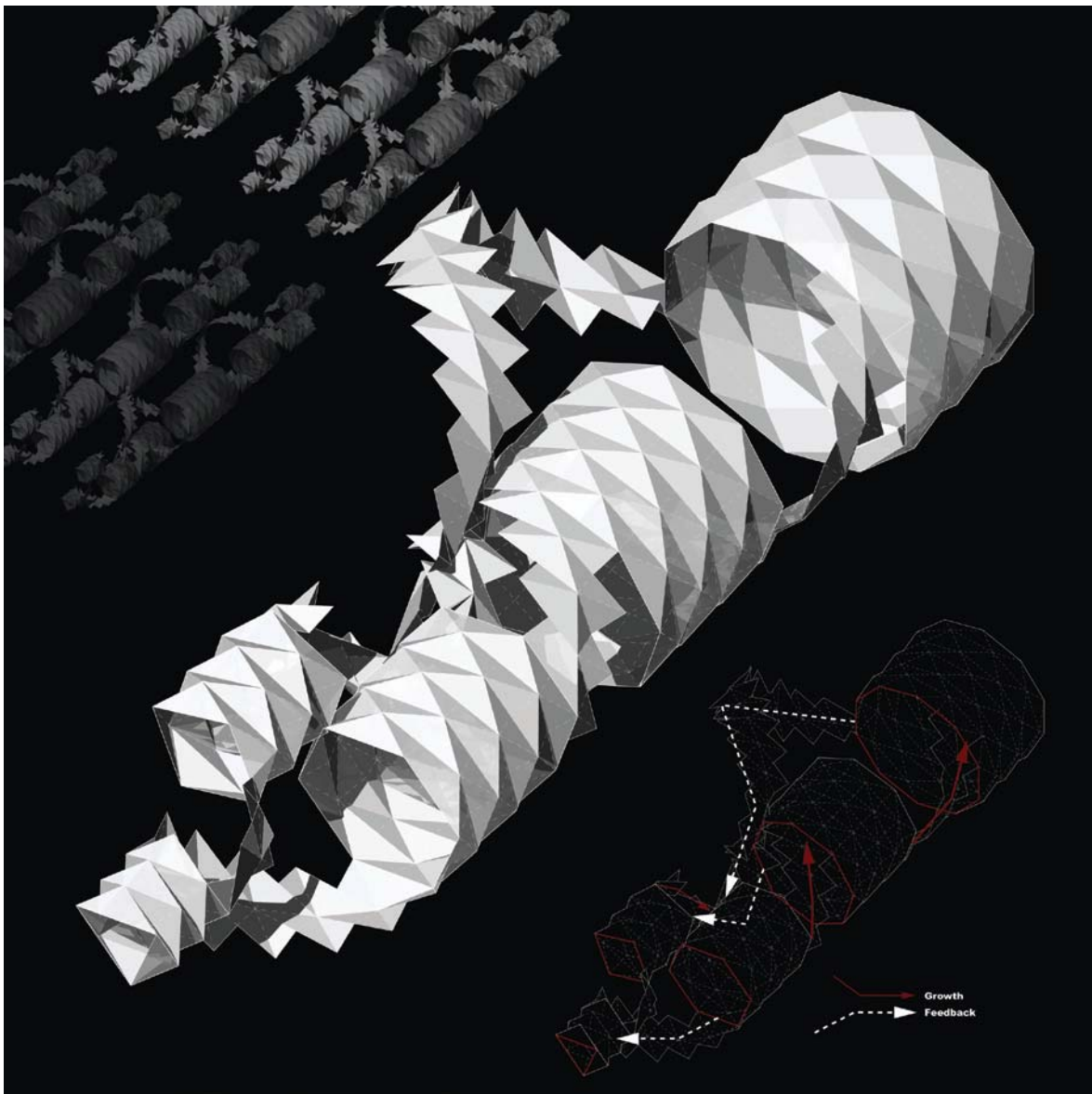

HYUNJOON CHO: Growth behavior, generative component, and continuity are terminologies that represent my work. Two projects were completed and are linked together; based on the general description of each project, I was able to design a structure that consists of specific components. However, it changes morphologically as it grows. In particular, the card project shows the behavior of components as it grows and, finally, how it ended up as a totally new construct. The other project is more complex and shows how components could be applied onto the system, and how well it is integrated within it. The main point of this exercise was to exercise our ability to visualize objects as whole instead of separate components.



AROUSIAK GABRIELIAN: Beginning this project with an investigation into topological surfaces, a module was developed that could function both as surface and structure. The developed module allowed for numerous connection combinations with varying degrees of porosity which enabled behavioral characteristics within the system including, bending, torquing, flipping, splitting, and lifting by alternating component connections and scale. This allowed the system to act both as floor, wall, and roof, while blurring the lines between these conditions. Scale was further manipulated at the tips of the system, as well as the width of the components, causing one end to morph into flat rectangular panels which merged with the ground exposing the “skin” of the component, and the other end to morph into flat x-shaped patterning which merged into the wall as a wall paper condition exposing the “skeleton” of the component. The result, housed in the Philadelphia Army, provides an environment for the display of 16 Civil War artifacts.

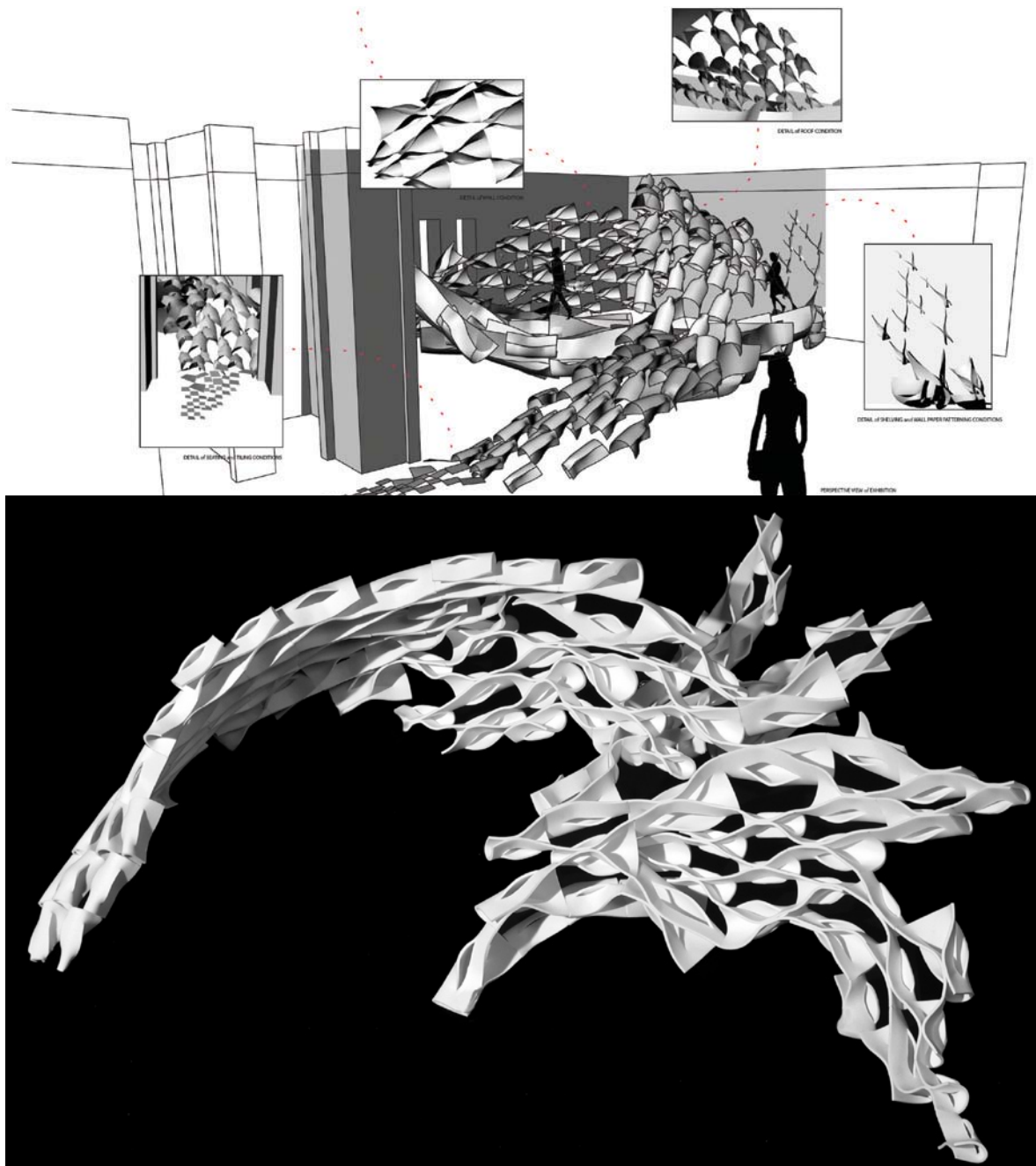

PABLO KOHAN: The circulation and structure for a civil war exhibit in the first city armory of Philadelphia was conceived by implementing a nodal network logic of organization to the artifacts within the prescribed space. While contemplating the violence of war visitors must negotiate their movements under and around the system of cables which suspends the artifacts.

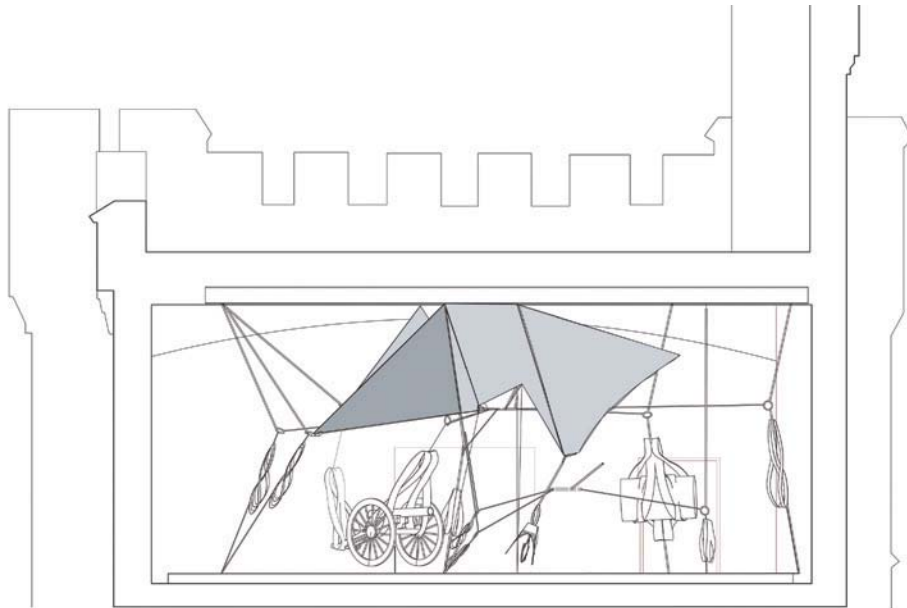

LAUREN MACCUAIG: Using formal analysis, scripting becomes the catalyst for investigating input-output relationships. Scripts form a netted field whose outputs are directly informed by environmental, programmatic and ecological inputs. The output engages the pavilion's site, a tidal basin, and forms a feedback loop when operating within a gradient shift from organic to rigid. A composition is created which fluctuates between porousness and non-porousness, resulting in a landscape which is active and inactive, loud and quiet, engaged and disengaged.

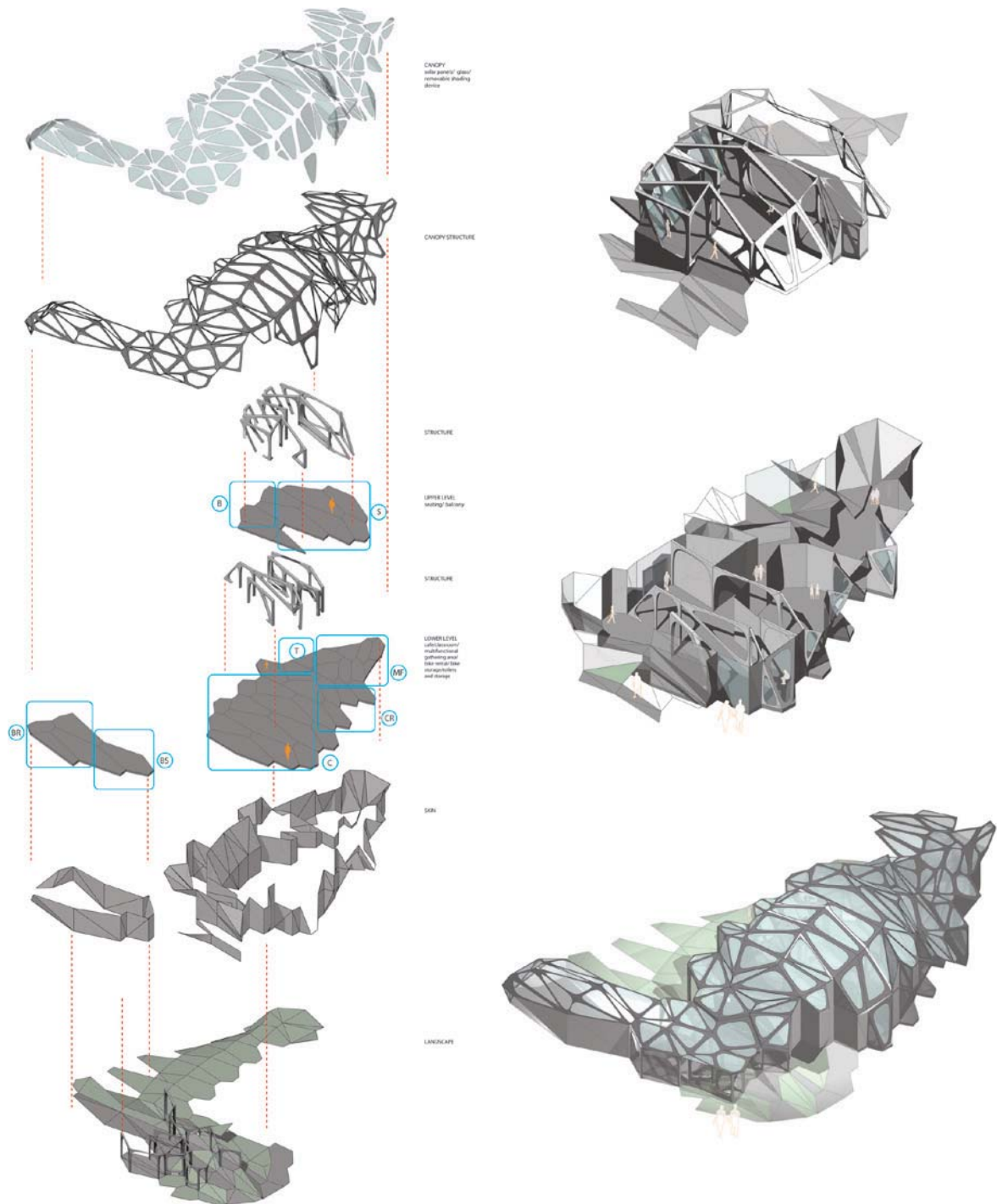

CHRIS MACKOWIAK: This project probes the limits of site specific architecture through literal site analysis. By reordering sequential strips of land, a canvas is created. This canvas is then bent, stretched, and folded to provide structure, form, program, and certain ancillary components which result in an ecotourism pavilion in the Galapagos Islands.

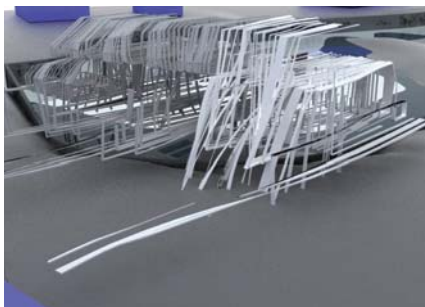
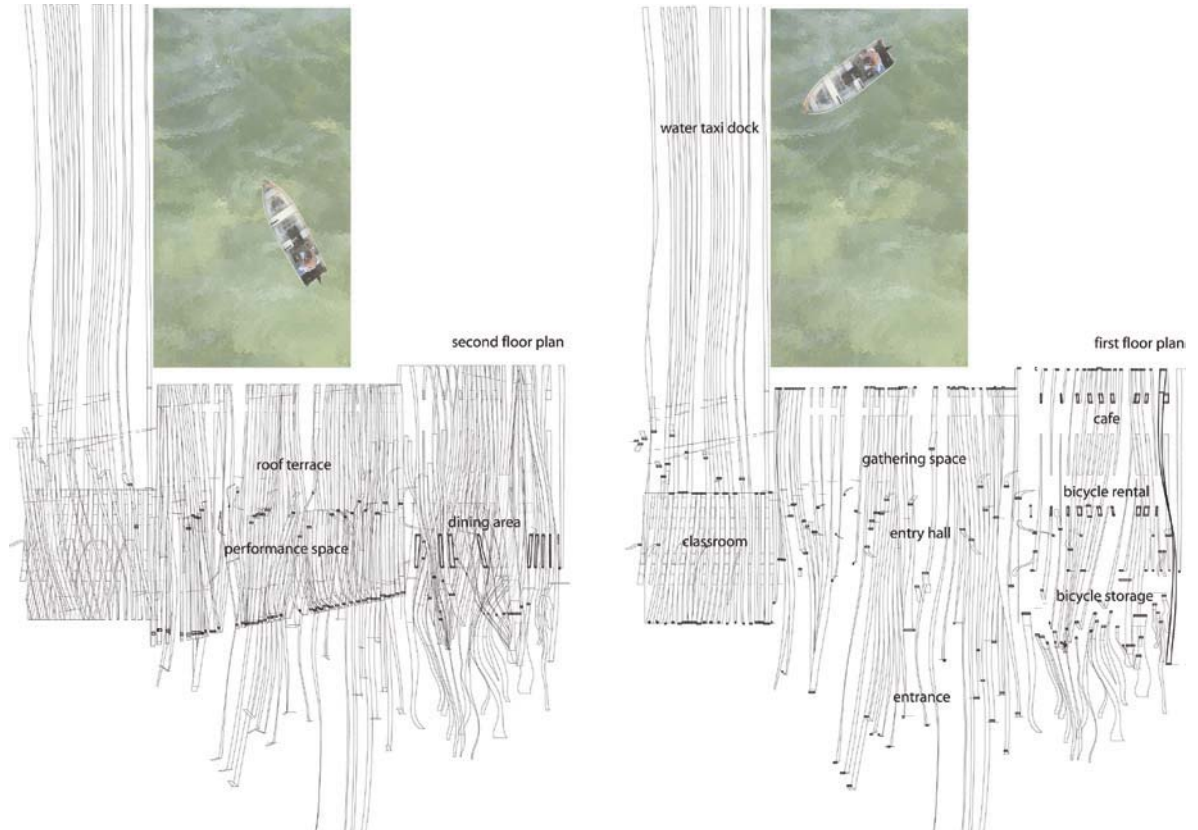

If the complex systems explored in ARCH 501 depended on models from geometric and figurative origins taken into spatial and formal variations, the second semester studio attempted the generation of similar organizational complexities, from origins found within the systems and networks of the city. Throughout the semester, experimental buildings and landscapes were generated from a myriad of conditions, processes, and observations suggested by the urban domain—from different urban morphologies to the typology of specific buildings, from the static condition of the existing landscape to its dynamic attributes, from the proposition of a centralizing social condenser subjected to the vacillations of regional movement and access. Each instructor oriented their respective topic to address an urban issue and proposed a generative methodology parallel to the studio's content. Some of these methodologies deployed specific digital techniques; others did not. The studio was organized in two parts: The first part of the semester addressed the role of the analytical model as a generative modality. The second part of the semester resolved a piece of the large program to the scale of building specificity: from form and spatiality, to material and structural, local systems of movement, and infrastructure.

Both culminated in one semester project: "Leisurescape," an alternative recreational zone and entertainment center located on the contested site of Penn's Landing. Problematic as a remnant of land long disconnected from the city proper by a large swath of regional interstate, the site—a large section of the Delaware river front—was also being actively scrutinized and hotly debated in civic arenas for potential casino development while the studio was being conducted. Fundamental in the studio's brief was the challenge to notions of conventional leisure and entertainment of American cities. Central to the studio's methodology was conceiving the built landscape as a dynamic entity, incorporated into and actively contributing to already changing demographic, infrastructural and ecological systems.

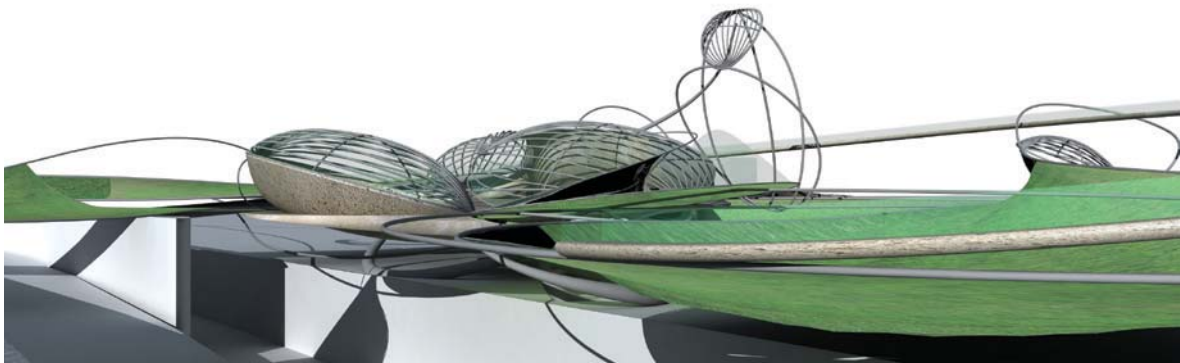

KARA MEDOW: Through material investigations, I re-evaluated forms created by the surfacing of sets of three coplanar points determined by an earlier site/program diagram. This yielded forms using wire clad with nylon. The order of operations by which the wire moved through points a, b, c and d was translated into predetermined sets of points from the original site diagram. This resulted in a form responsive material model translation of the original program network.

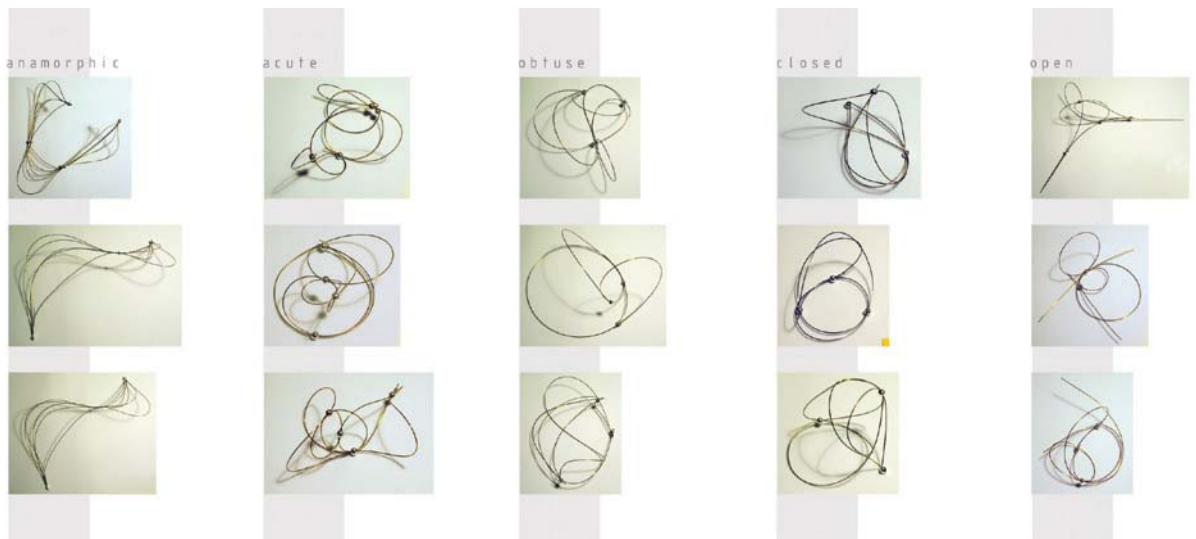
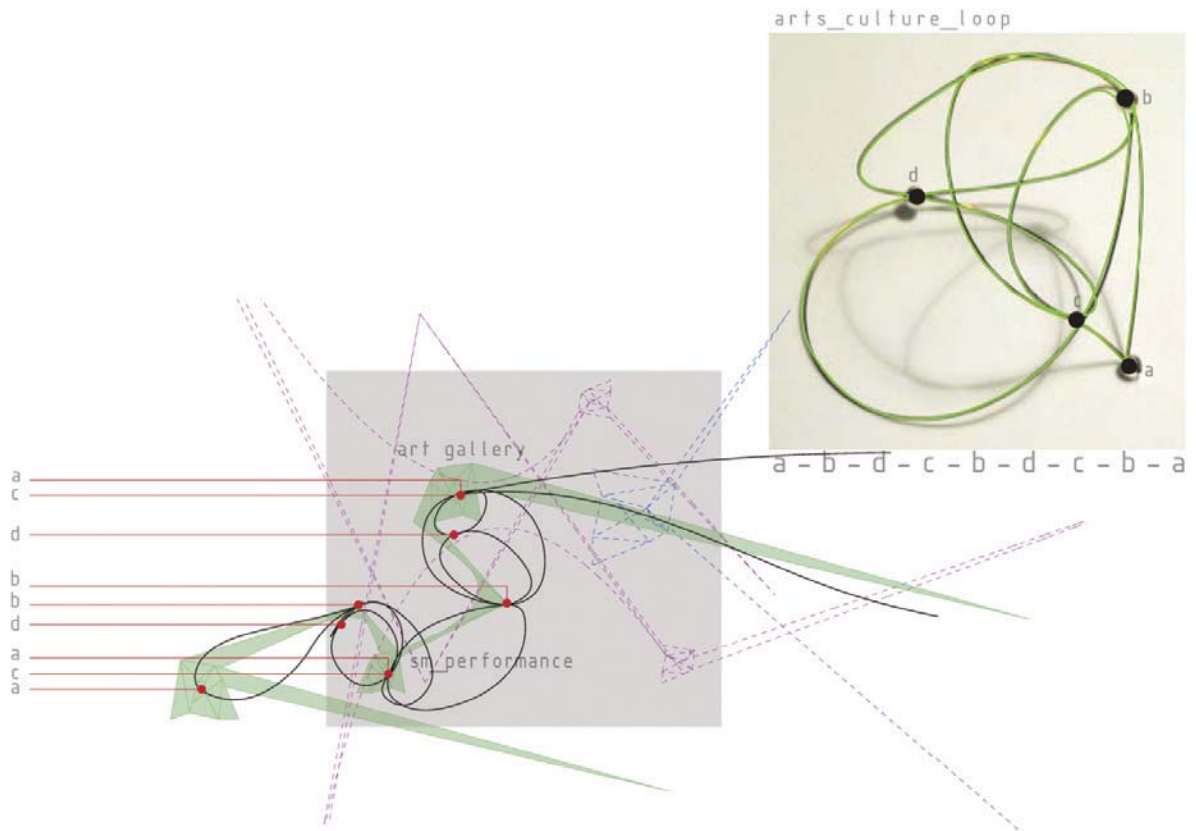

TODD MONTGOMERY: In this studio we were asked to design a "Leisurescape" at Penn's Landing. My project focused on the redesigning of a fleet of barges that could carry and remediate the polluted soil coming from the proposed dredging of the river, but could also roam the river as party boats, constantly shifting the landscape and offering an unlimited range of combinations of program and experience.

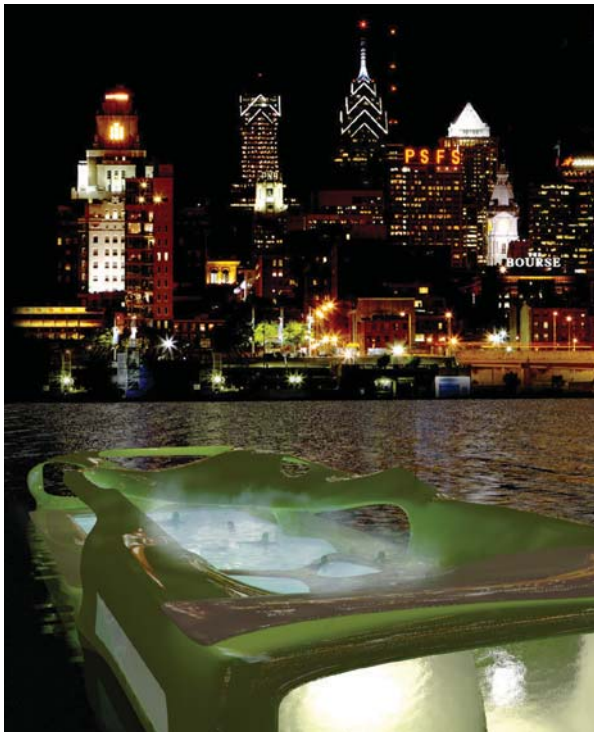

JOSHUA FREESE: The studio was an investigation into parametric methodologies. Using the explicitly defined site of a dock-block, a series of layers were developed in response to the constraints of the dock and of the intended program. These layers were generated using techniques that generated surface and spatial conditions responsive to optimizing performance in both structure and program diversification. A sectional hierarchy was established to integrate these layers, creating a building with a processional ascension from the street to the roof park through the various programmatic layers.

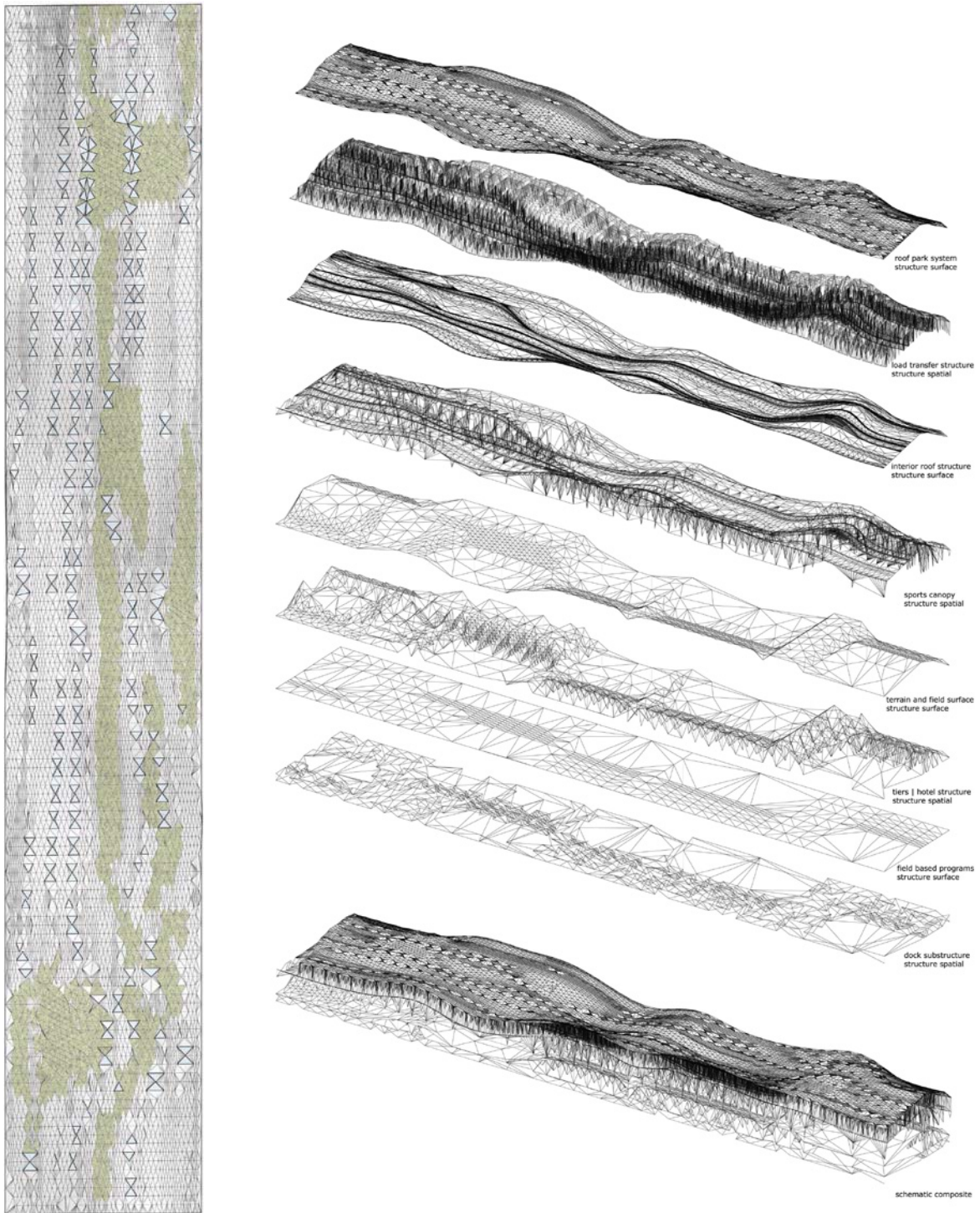

DAN AFFLECK: Research was conducted on three building typologies: the cinema, the art gallery and the hotel. These simple typologies were radically reinterpreted to accomplish an abstract performance of interlocking, using a one-way surface structure. The new cinema-gallery-hotel typology was interwoven with Interstate 95, which disconnects the city of Philadelphia from Penn's Landing. More than covering over the highway, the new interlocking leiscurescape activates a previously dead zone which cuts the city off from its waterfront.

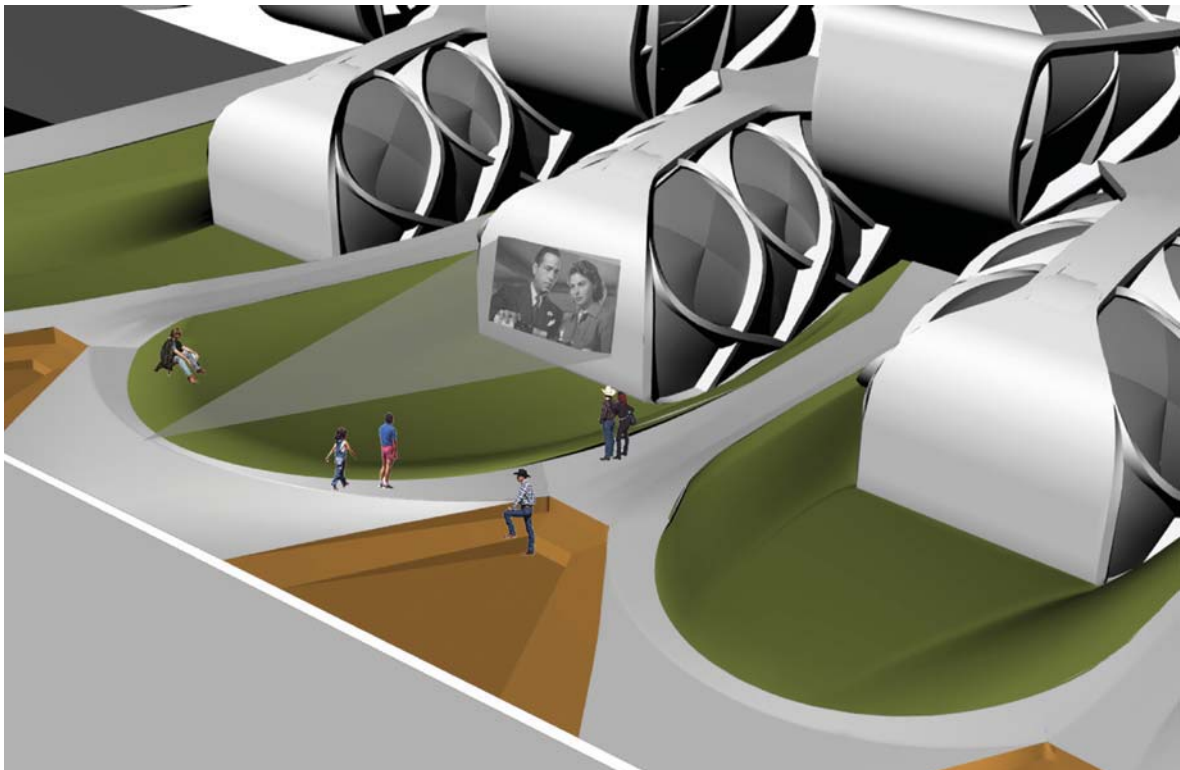

BRYAN KELLEY: This project implements weaving as a generative device to redevelop the Delaware waterfront by linking existing leisure activities in Old City to a new hotel, marina, and entertainment venue at Penn's Landing. An abstract catalogue of weaving and knot typologies was developed to produce variations which operate differently at various scales.

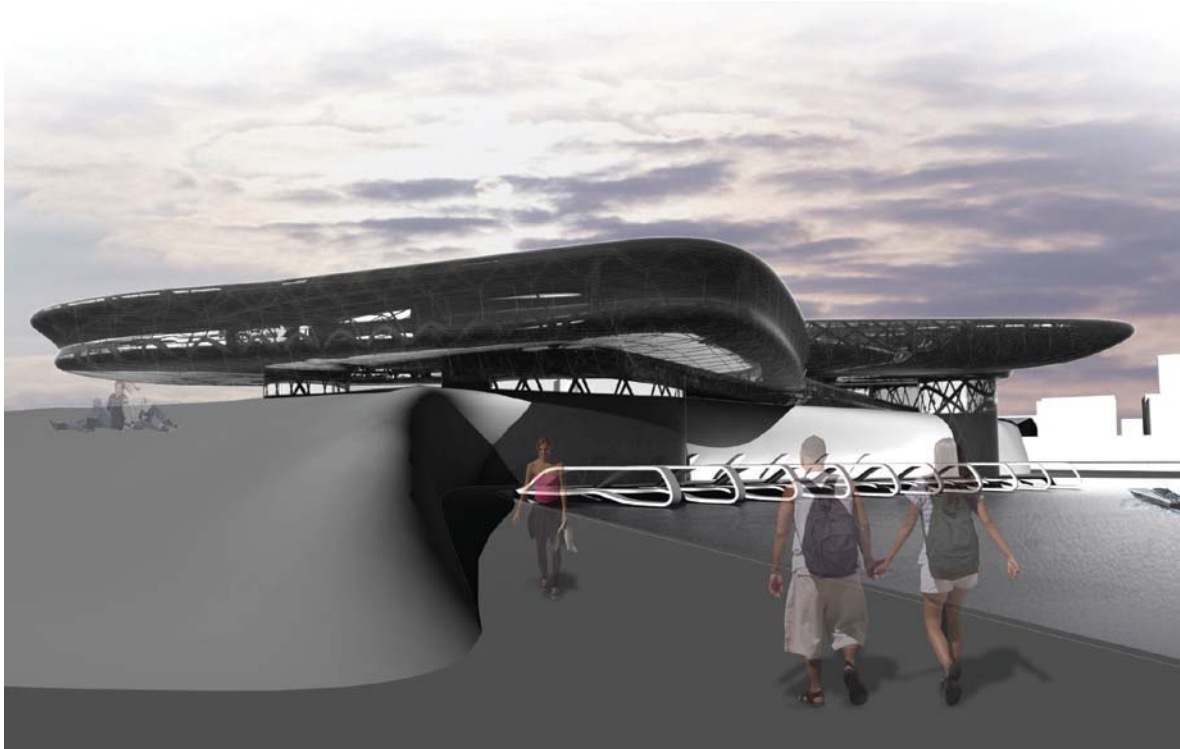
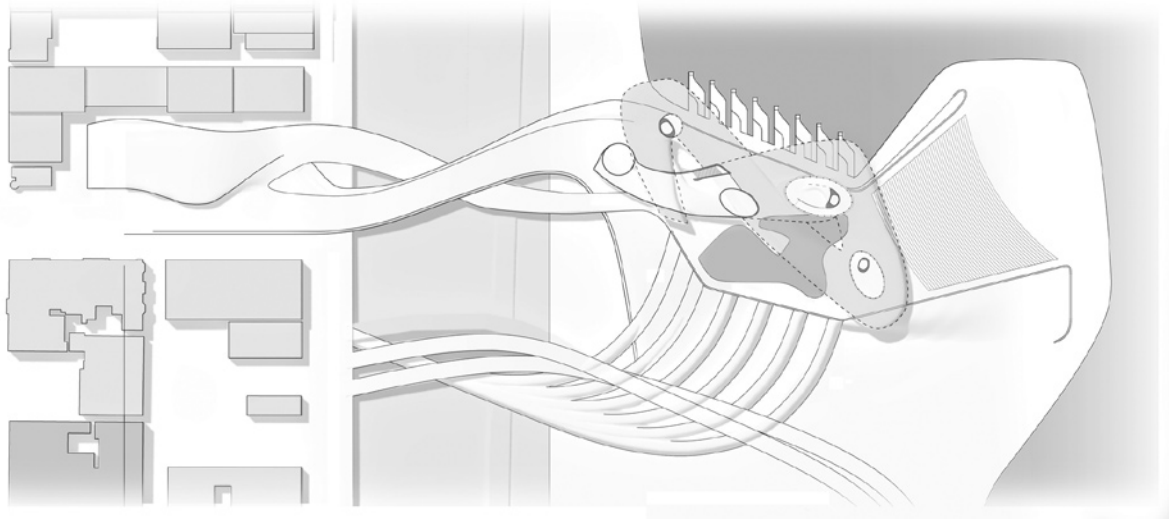

ARCH 601

DESIGN STUDIO III / TECHNOLOGIES AND ECOLOGIES / WILLIAM BRAHAM, COORDINATOR

This was the first intermediate design studio and consisted of six independent sections, each with its own orientation to issues of technology and ecology. Design projects involved complex public or institutional buildings, and required the detailed resolution of one ecological and technological dimension. Ecologies were considered in their natural, social, and technological dimensions, and in various degrees of abstraction and realization. This included affinities between modes of analyzing and operating within natural ecosystems and systemic models of analysis of organizations, economies, urbanisms and material cultures, alternative economies, and the cultural politics of environmentalism, as well as the study of energy and resource use, recycling, environmental quality, and biomimetics. The studio was taught in close collaboration with Visual Studies Workshop III, whose techniques and exercises were tailored to each studio section.

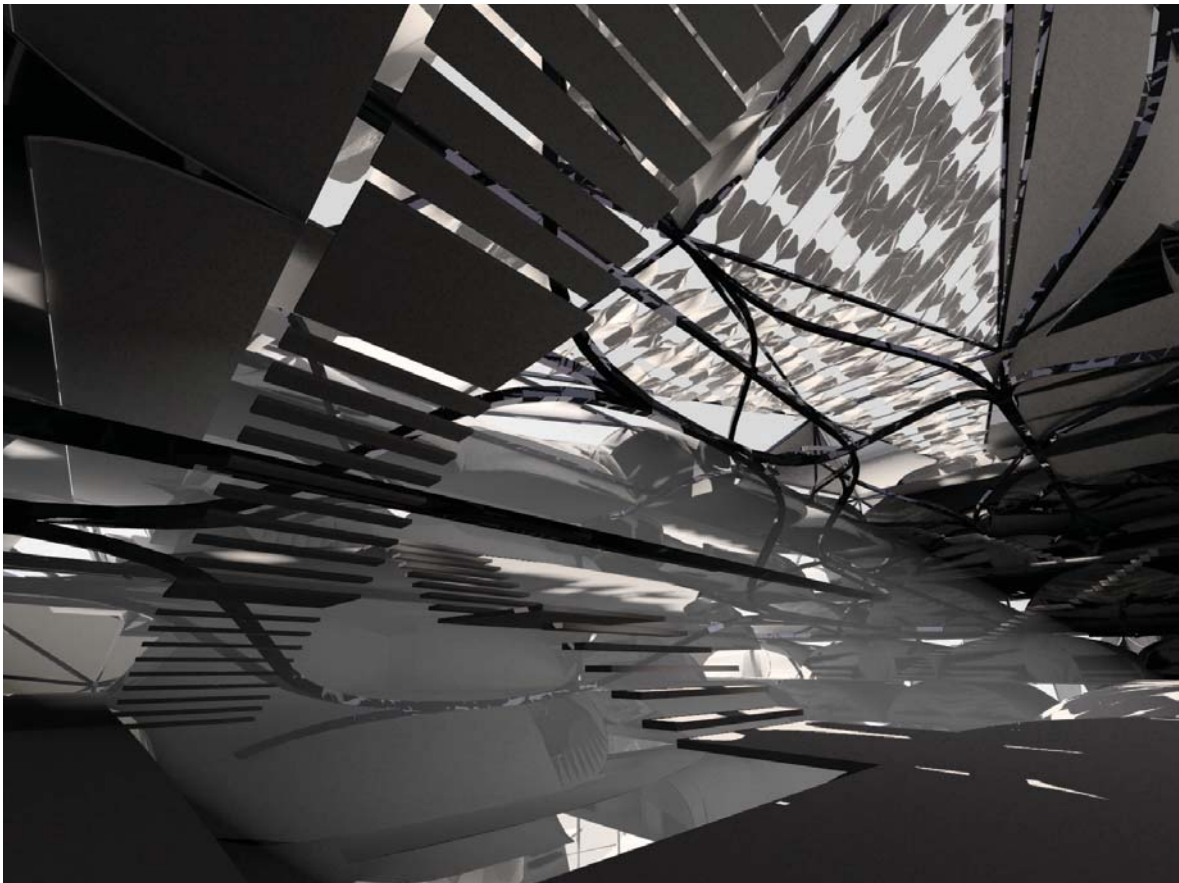

ILLUMINATED CELLS

In cellular structures—living or made—individual cells are differentiated according to surprisingly local logics—inside cells differ from outside ones, surface from openings, vascular from muscular—all depending on where they are. The studio explored the proposition that the process of design can be similar to epigenesis, in which cells differentiate according to position, function, and their response to immediate surroundings. The studio translated cellular logics from detailed scans or reconstructions of existing cellular matrices, adapting and testing them for the response to illumination. Analytical studies addressed both visual qualities and lighting levels, using physical and digital models.

NERIJUS PETROKAS: A theme for the Penn Hotel project is the light which defines spaces. The experience of the building is inward oriented both on individual room scale and the hotel as a whole. The rooms allow no outside views, and the light entering from above becomes that which creates the experience inside. Public meeting areas are organized around the theater of light. Shadow play on multiple surfaces and light beams filtering through the hotel “crown” and penetrating air down deep the atrium give forest-like mystery and create scale and distance ambiguity.

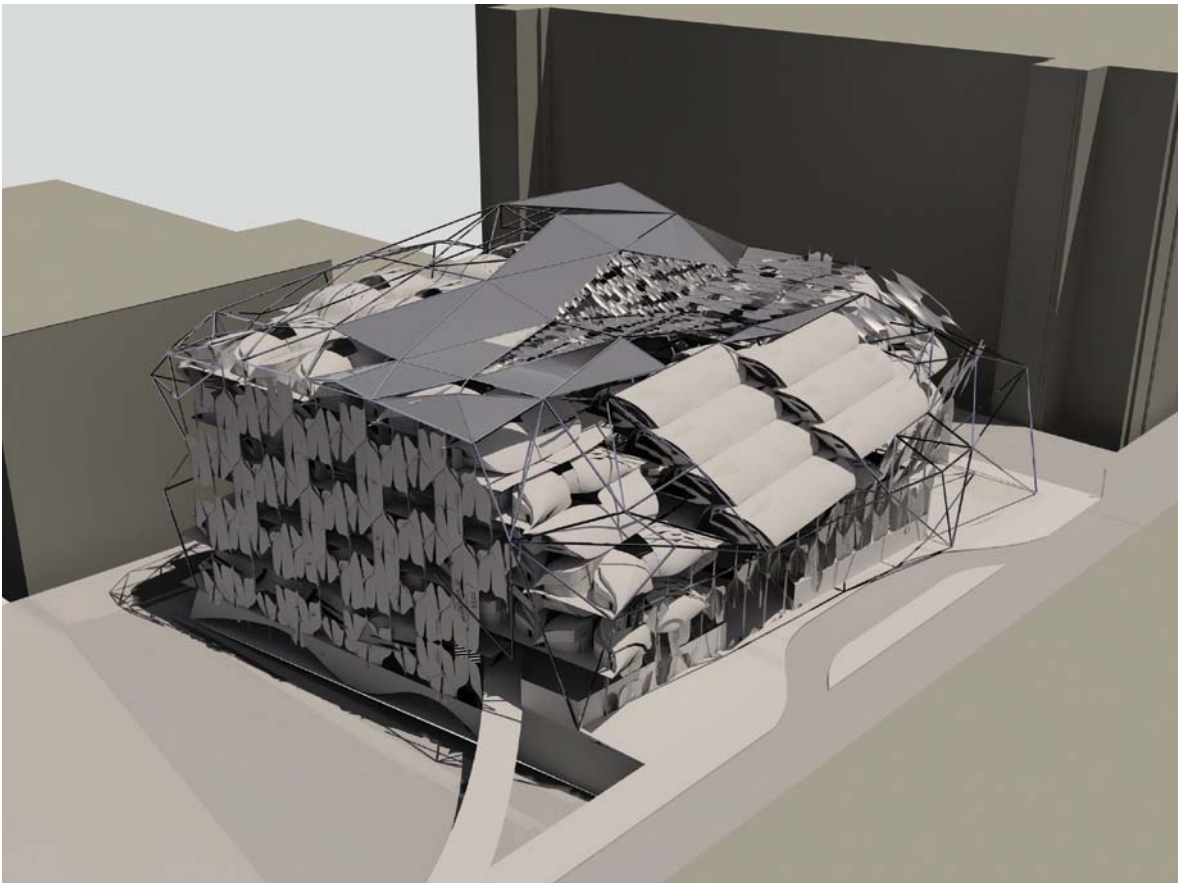
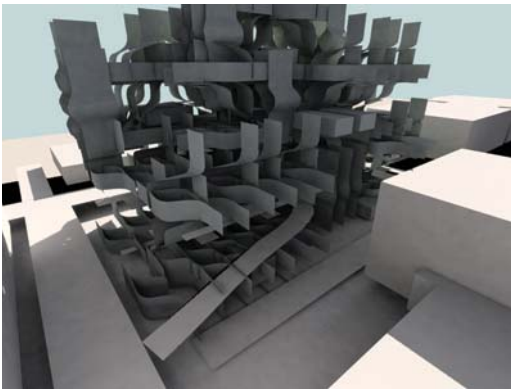

WASTE

The TSR Master Plan identifies four housing types potentially developable in the region: (1) luxury/upper-middle class housing; (2) moderately-priced average-quality construction sales housing; (3) affordable sales and rental housing; and (4) amenity-enriched, competitive single-family homes and twins. Each typology however, has limitations that prevent them from being immediately deployable at this specific site. The market for luxury apartments has been focused more within the Center City region, while the single family detached homes are found in the outer suburbs. Moderate housing necessitates cheap land sales, and affordable housing usually requires government subsidies. Consequently without additional resources, no permanent installation can be developed with sustainability. These resources are not only economical but may also be social and political.

The final studio project utilized any number of these four typologies, developed to a set of minimum requirements. There was no assumption that any of these types is more beneficial to the local economy or social dynamic. Gentrification was understood as both a negative and positive factor. Similarly maintaining lower income neighborhoods separate from others was not necessarily considered an outdated idea. Specific care was made to avoid generalizations and large assumptions.

HOUSING + HYDROLOGY ON THE SCHUYLKILL

MEGAN BORN: Data collected through site visits and research prompted the design of housing coupled with a hydrological system. Water is collected and filtered through wetlands, shared by occupants in public wet spaces, and cleaned on green roofs and terrace gardens before being released into the Schuylkill River. The project is independent from the sewer grid of Philadelphia; water is fuel, rather than waste.

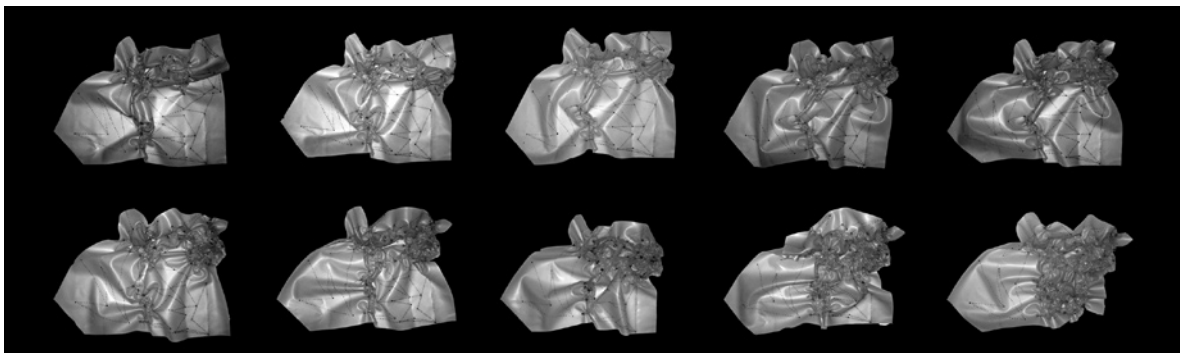

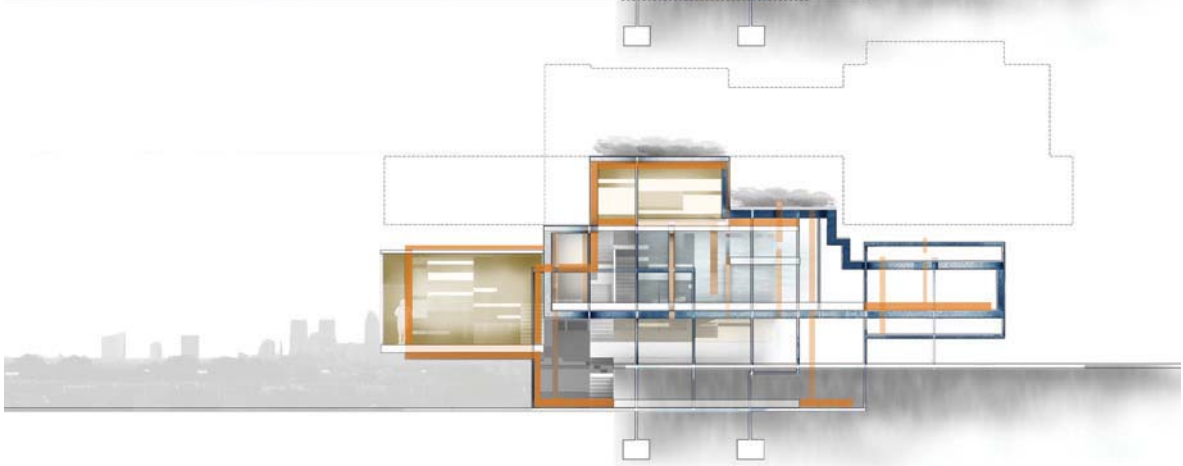
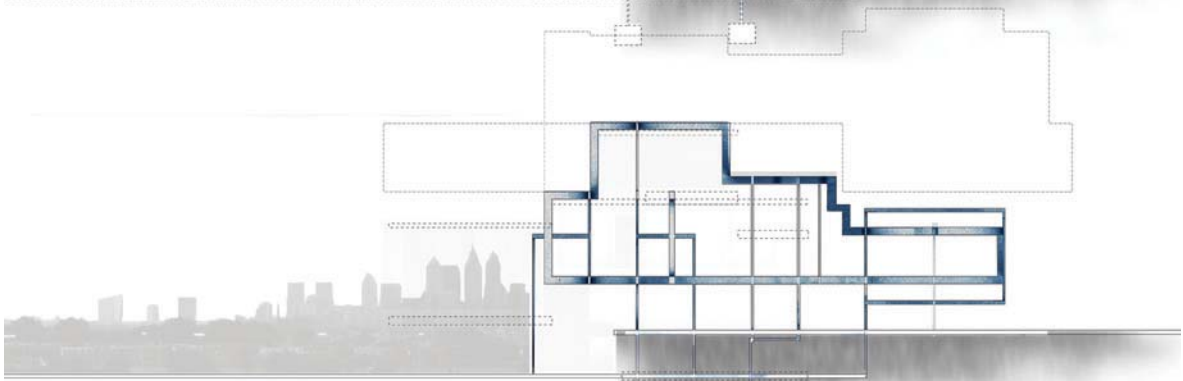
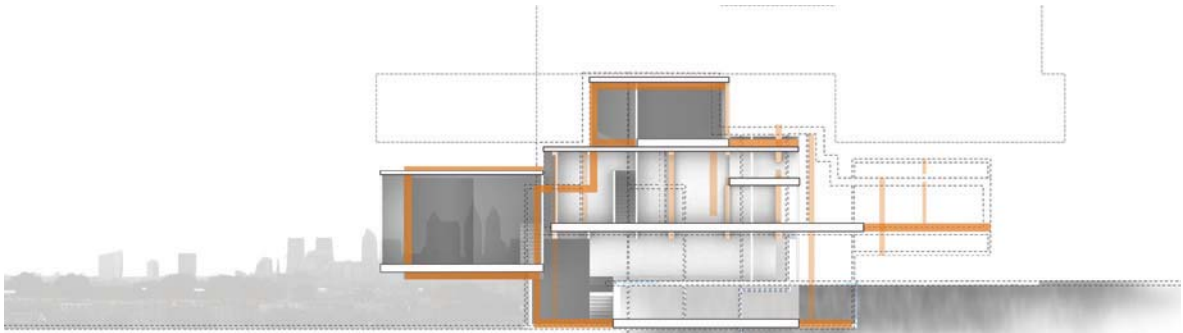

PATULOUS STUDENT COMMUNITIES

Many universities are experiencing unprecedented growth in their student populations. This growth has placed great strain on existing campus facilities and has resulted in a shortage of student housing. This shortage, combined with the high cost of new construction has created new models for student housing—the hybrid. This structure is often a development that incorporates housing, recreations, retail and group study areas. This new hybrid is fertile ground for investigation into the social potential of university housing, and how its 'off-campus' nature can expand to forge new relationships with surrounding communities.

There is an inextricable link between purpose and form. If one studies objects of purpose: a hand tool, milling machine, or cell phone, the formal deposition of each object is a clear example of its expression of reason and universal legibility. This legibility invariably insulates the object from discussions of style as a measurement of value: subjectivity is replaced by objectivity.

The pedagogical objective of this studio was to develop problem-solving skills that are directly applicable to architectural practice. These skills were based on a heightened awareness of and attention to site, program and building systems and sustainable technologies.

JIN KYU KANG: The Spring Garden neighborhood of Philadelphia is a residential community densely packed with two and three-story row houses. Our site was an undeveloped plot adjacent to the SEPTA train line. My 'apartmentory' (apartment + dormitory) features a Vierendeel truss system to dematerialize the walls, maintaining visual continuity through the site. The building wraps around a soccer field to be used by the residents and the local community. Restaurants, shops, and supermarkets at street level aim to revitalize the neighborhood and renew civic pride.

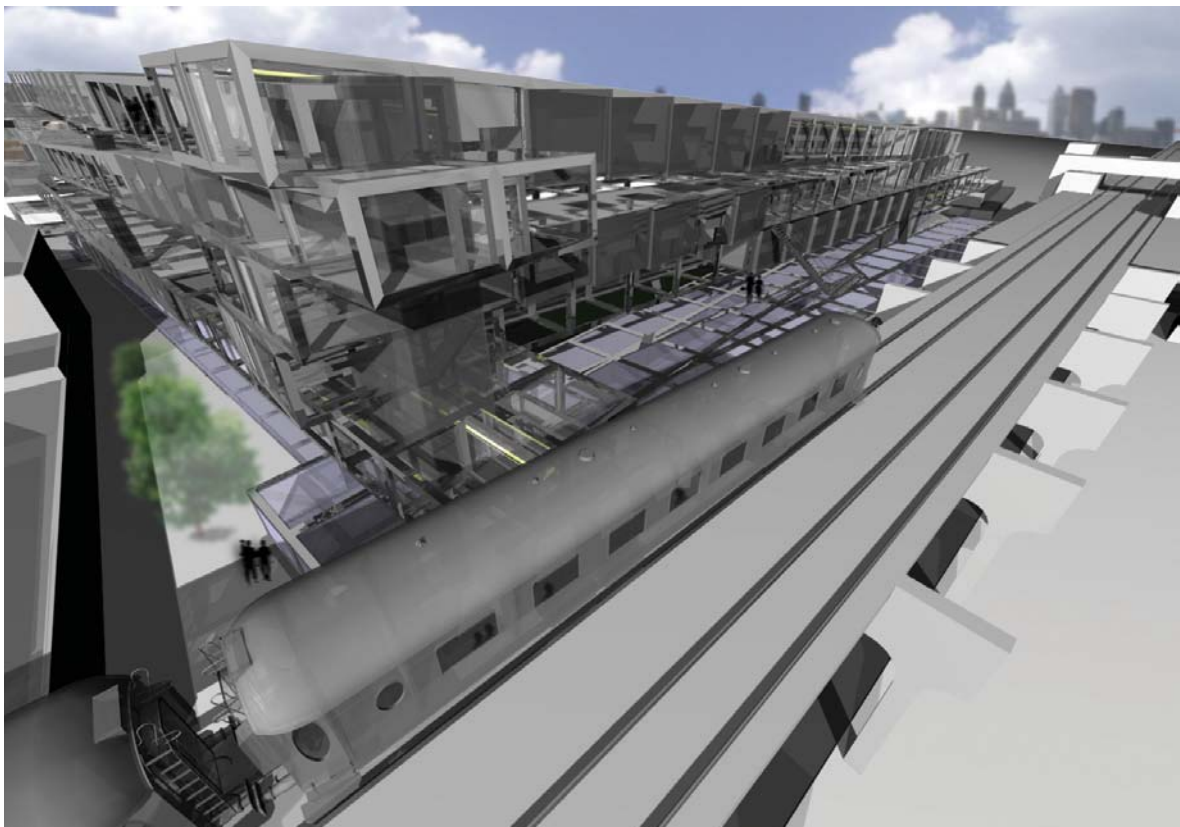

SITE PLAN



DE...COM...SING - EACH PARTS

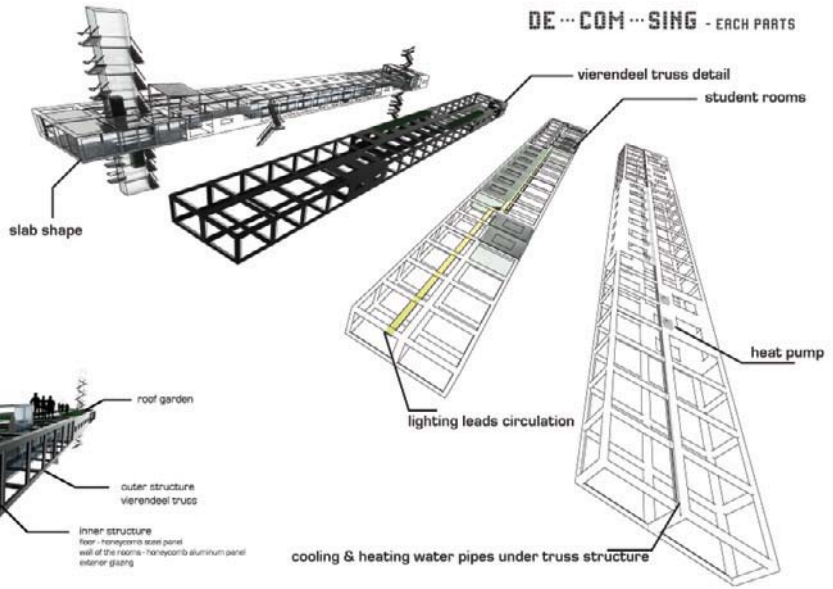

SINGLE UNIT

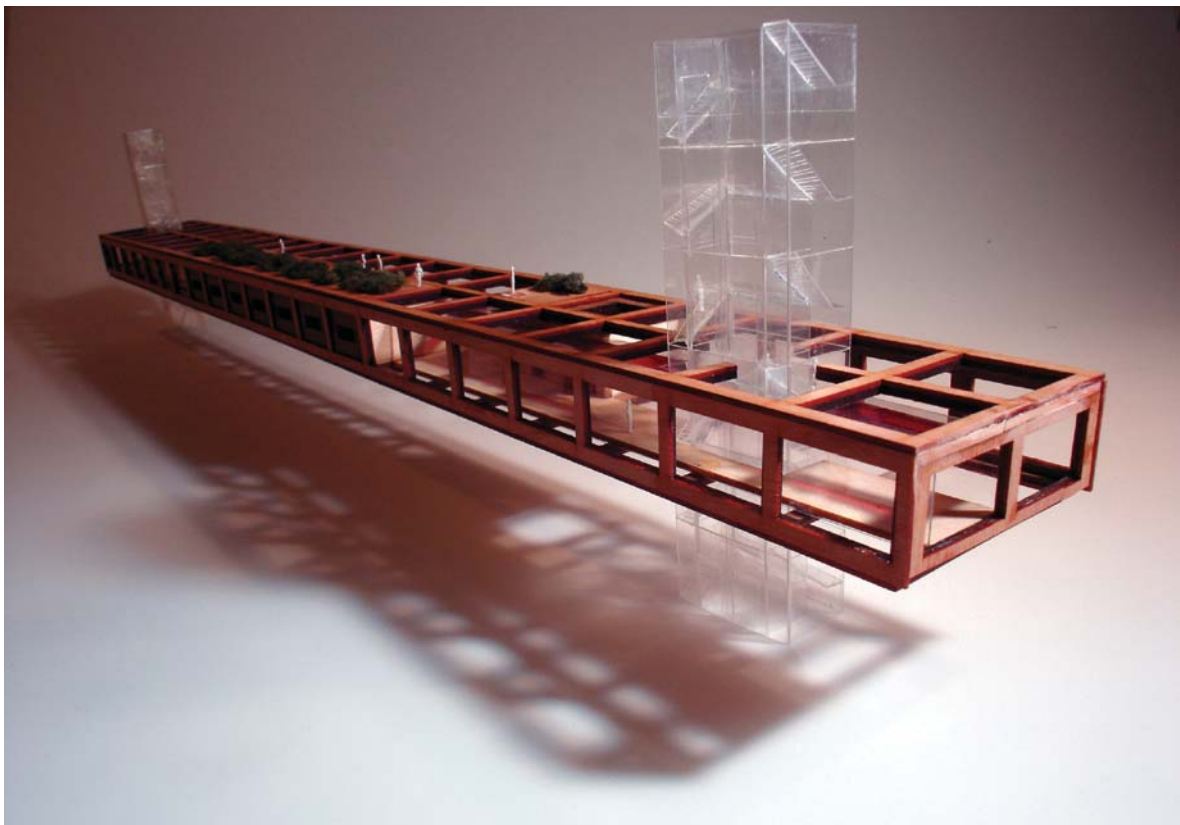
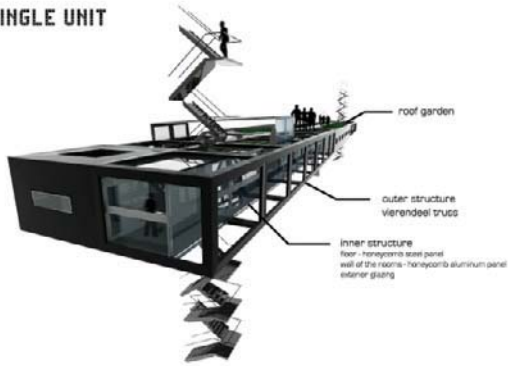

EVOLUTIONARY RECIPROCALITIES/ PLANTS + PARAMETRICS: THE CHIA-ROSCURA SCHOOL

The program for this studio was an elementary school with an explicit curricular agenda (taken from an actual initiative in the UK) to integrate landscape as a primary way to promote diverse learning activities outside the classroom. Building and landscape became interactive, didactic elements in their own right in the pedagogy of the school. To this end, the characteristics of the exterior were given exactly the same weight as those of the interior, in a process of constant symbiosis. The constituent components of building were interchanged continuously with the constituent components of landscape and gardening.

In positing building as landscape and landscape as building, the studio examined the potential of incorporating actual biological material as literal components of building. The studio's methodology hinged on an analogical investigation of a conductive interface which served as a basis for understanding the necessary transfer of air, light, water, and heat through and into surfaces. Geometries generated were confluent with the delivery and interchange of life-giving necessities, yet also constantly impinged upon by natural events and human activities. This method of generation was paralleled by an equally weighted technological investigation taking on the possibilities and necessities of particular plants or gardening processes, to be utilized in tandem with the demands of articulate, animate, and highly developed systems for sustainable building. These were developed to a high degree of resolution early on, implicating detail as a primary impetus in developing building form.

JILL LAGOWSKI: This design of the Chia Roscura charter school was intended to blur the distinction between city and landscape through a component system which integrated plant life and urban activity. The classrooms were designed to immerse the children in this redefined urban landscape, both visually and audibly, in order to encourage interaction with and learning from the shifting boundaries.

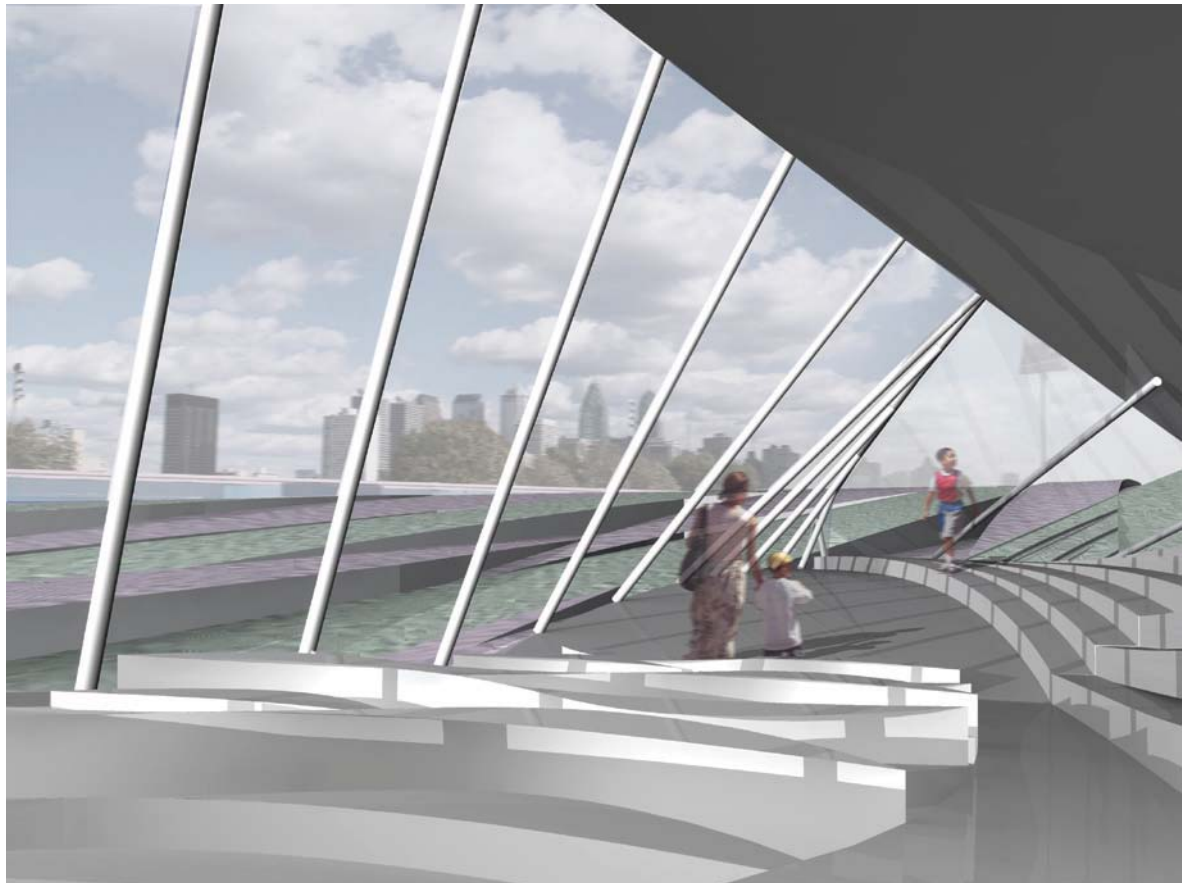
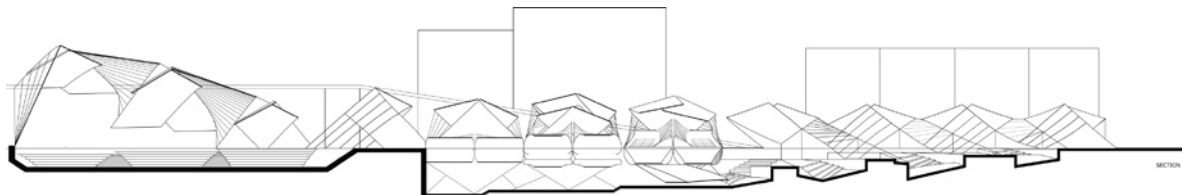

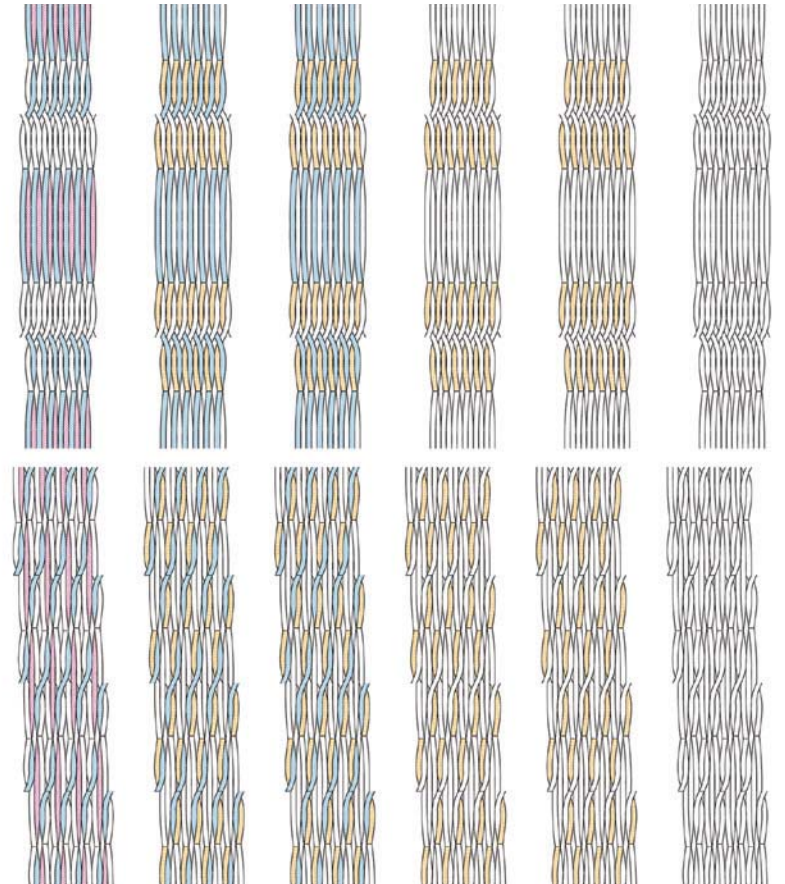
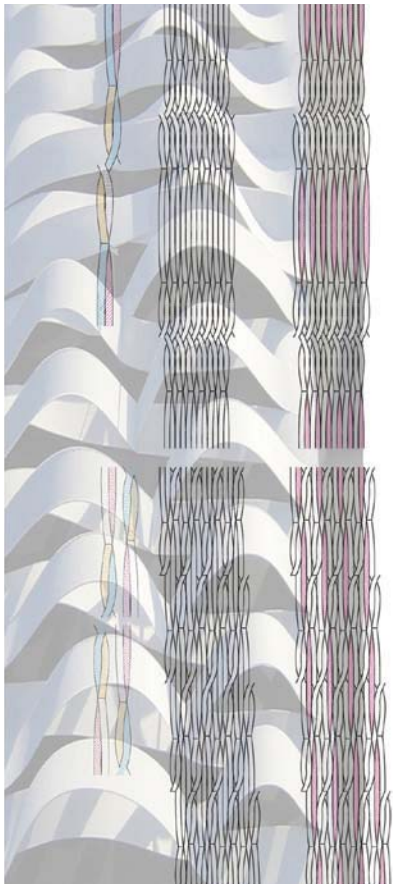
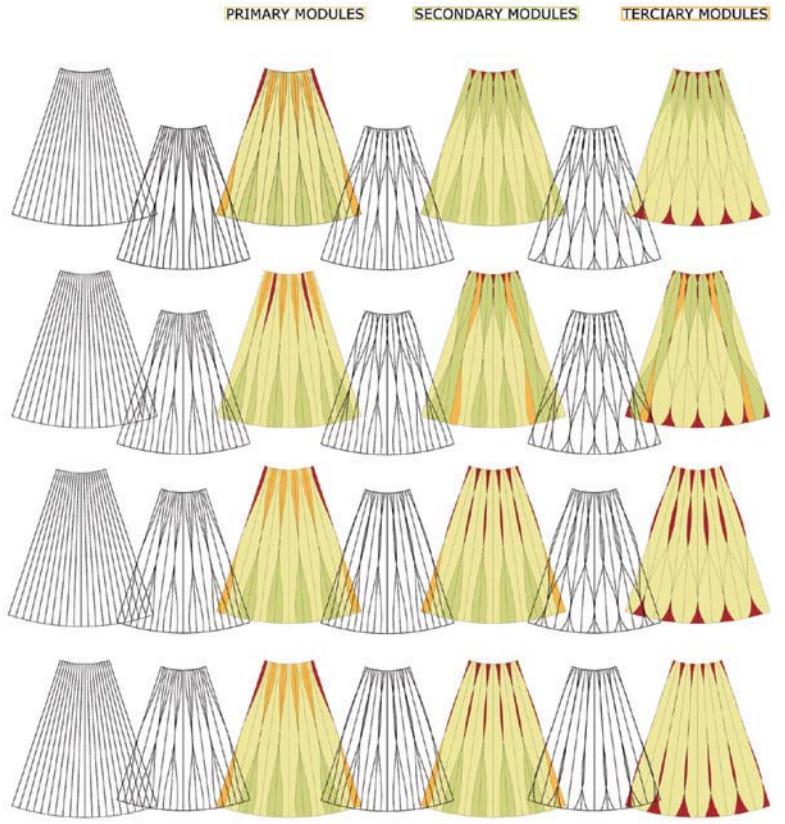
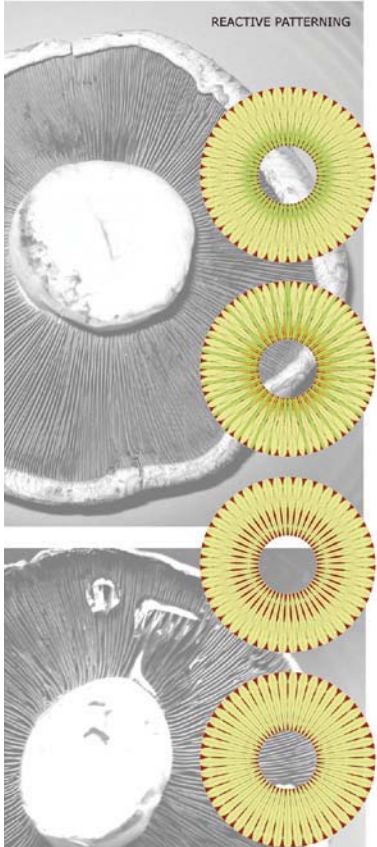

PCX, PHILADELPHIA CLIMATE EXCHANGE

Though nature and capital remain sublime in their difference, this studio examines their collapse into a single environment of monitoring, management, opportunism, and publicity. The affinity of the market with climate science is computational and methodological. There are also affinities of desire—for accumulation and fair weather, for specificities in forecasting; and of ubiquity—each is everywhere present.

To what extent can architecture instrumentalize time-varying phenomena as pattern or form; and to what extent is architecture obliged to interface with time-varying phenomena in terms of environmental and site qualities and quantities? Architecture consumes resources, demands the expenditure of vast sums, and is undeniably involved in the exchange of energy and capital and the global distribution of material. Architecture is implicated in the social and environmental effects produced via exchange. Projects in this studio aimed to be cognizant of issues of ecology without taking up the facile positioning of green architecture.

This project was designed for an inevitable typology, the climate exchange: the convergence of climate science, resource management, financial risk, and investor and other publics. With a specific focus on the site and spectacle of exchange, we examined the design implications of converging practices of information production and processing, strange weather, and supporting forms of organization. The material and form of this intensified speculation required a position vis-à-vis program, programming, pattern logics and expanded surfaces.

ROBERT MAY: In a new business paradigm which combines both economy and ecology, the project examines the surface of exchange at multiple scales through the manipulation of two traditional typologies: the plinth and the office core. These typologies are then manipulated around four base programs in order to maximize the exchange of information based on the principle that maximum exposure leads to maximum exchange.

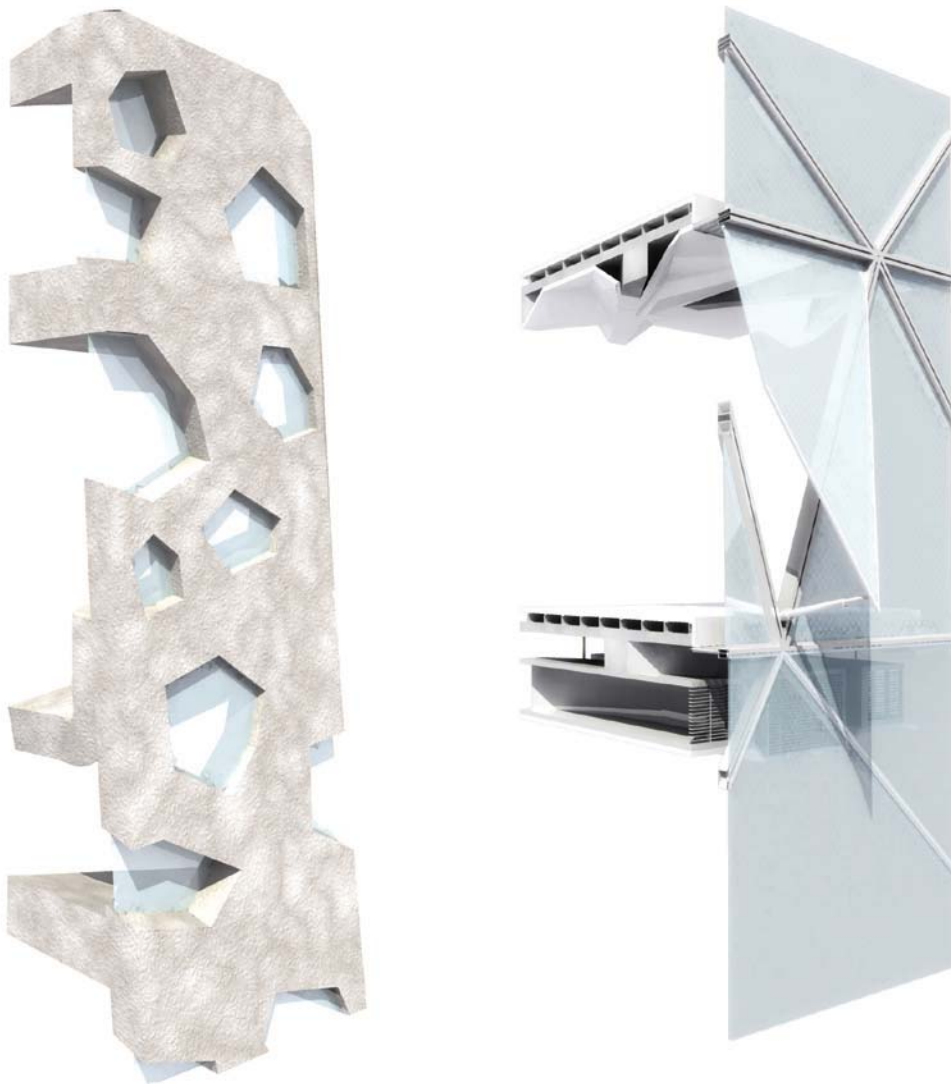

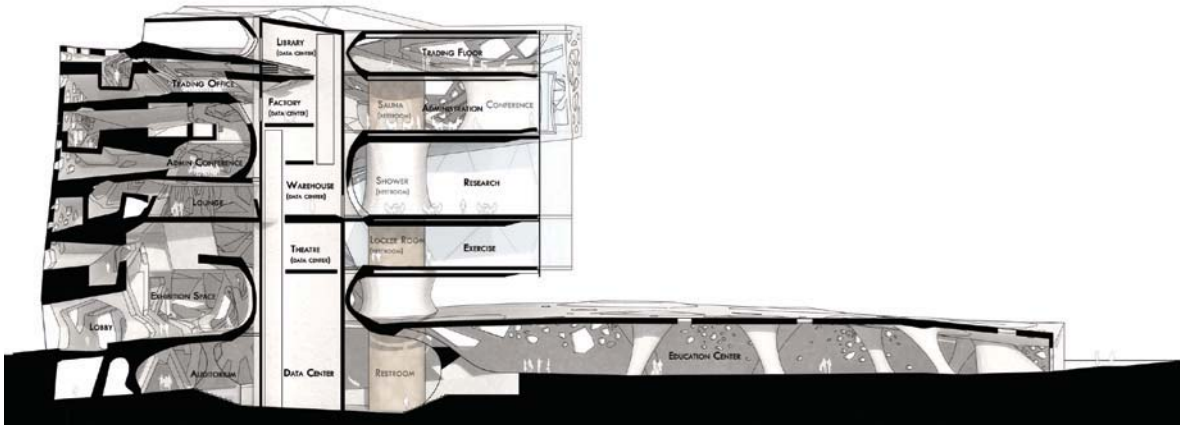

THE AMERICAN SUBLIME: THE NATIONAL PARK SERVICE MUSEUM AND RETREAT

Spanning 84 million acres across 390 sites in 49 states, the National Park Service (NPS) is the steward of America's natural treasures. Brought into official operation as a federal agency under Woodrow Wilson's administration in 1916, the NPS has grown to be the largest organization of its kind today. With a multifaceted mission of stewardship, education, and research distributed over a vast landscape, the NPS plays a central role in presenting an identity imbricated in the narrative of a sublime American frontier. In contrast to the concept of the natural resource, the "units" of the NPS are presented as objects outside the domain of economic consumption—they are treasures to be fixed and preserved. In this context, the most striking aspect of this agency is that it acquires its power as a collection—a collection of the most important events in America's natural history, making it perhaps the largest museum in the world.

The studio examined this collection of national treasures and investigated design solutions attuned to the NPS's astonishing mission. The proposed program combined a public museum with a private retreat for researchers studying the future of America's natural history. It is a consolidated presentation of the NPS's mission and a contemplative setting for planning its future. The challenge of the program was twofold. First, the museum needed to effectively "miniaturize" the vast terrains of the NPS and present as viscerally as possible a collection that could easily take a lifetime to explore. Second, the retreat needed to deliver to its guest researchers those sensations conducive to a deep contemplation of geological time—designers needed to reconcile the powers of architecture with the powers of nature.

ANDREW G. RUGGLES: This project was an investigation into how certain complex mathematical surfaces can integrate a collection of disparate program spaces into an effective and interesting assemblage. This assemblage offers a variety of moments where physical, visual, and audible connections are created between separate spaces. Experiments in tessellation and surface subdivision helped create a system for breaking these complex geometries into finite component pieces.

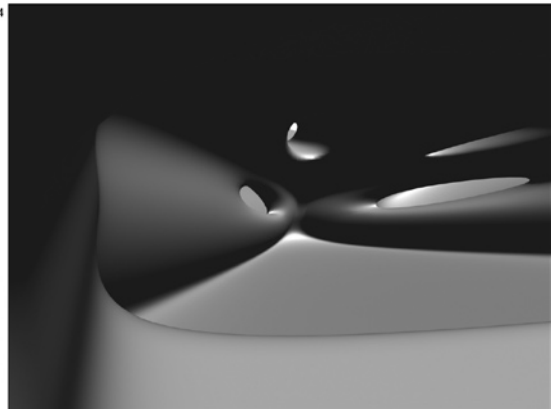
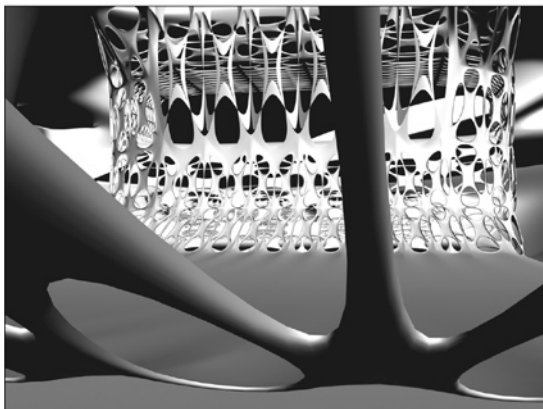
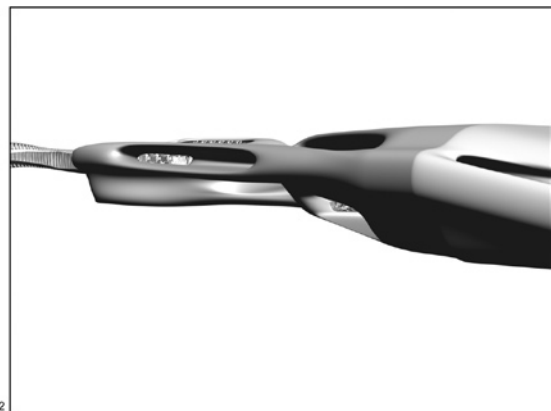
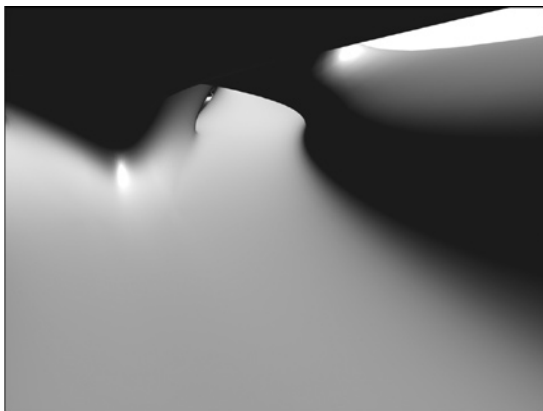



ARCH 602

DESIGN STUDIO IV / INTEGRATED DESIGN / FERDA KOLATAN, COORDINATOR

Integrated design is often understood as a layering of vital yet largely autonomous systems into a functional and coherent whole. Different technologies are linked and combined in a hierarchical manner to create buildings through large assemblies of individual parts. Yet, in conjunction with new fabrication techniques and intelligent building materials a less hierarchical and non-linear set of strategies have emerged, which may constitute a re-evaluation of the design process in general. The 602 Integrative Design studios investigated how these recent advances have begun to alter the way Architects look at the problem of integration. New opportunities to achieve a more coherent and organic integration are being tested towards complex and sustainable design solutions. Throughout the semester professional experts such as engineers, fabricators, material researchers and landscape designers were invited to join the studios at reviews and during workshops in order to provide the students with a precise understanding of the contemporary state of building integration.

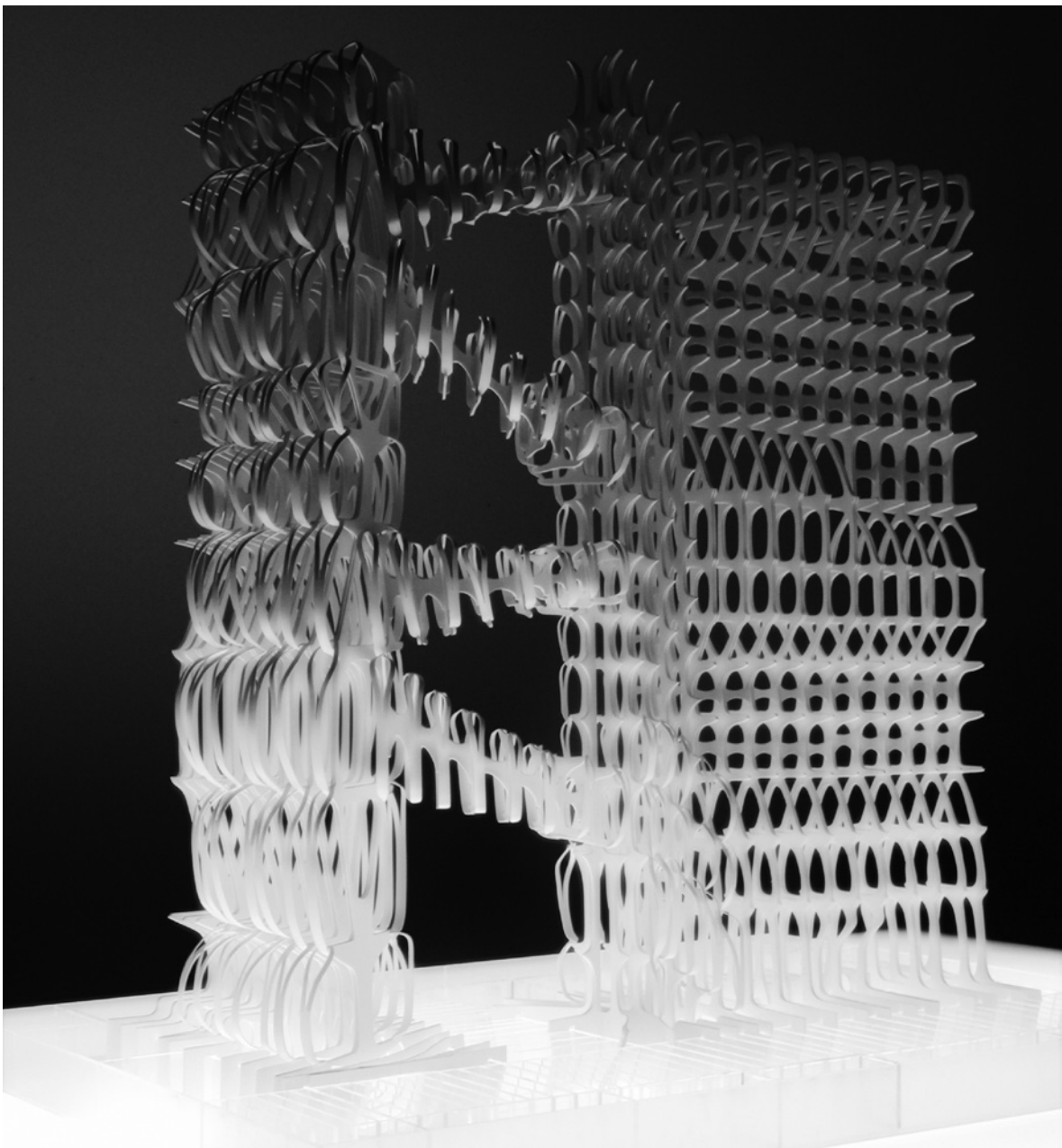

HOX_RISER / VERTICAL ARTIST STUDIOS IN LES/MANHATTAN

“Hox genes function in patterning the body axis. Thus, by providing the identity of particular body regions, Hox genes determine where limbs and other body segments will grow in a developing organism.” —Wikipedia

A BIO-LOGIC APPROACH TO INTEGRATION

Building integration is commonly viewed as the layering, linking and combining of autonomous systems into a large hierarchical assembly of individual parts. This approach often favors the normative over the specific or results in highly specialized and thus inflexible solutions. Conversely, design systems build on reciprocity and inter-scalar relationships allow for customization within a flexible template (or network), which can be continuously refined as a whole and yet produce multitudes of individual applications. Integration here is defined by the close and intelligent interaction of individual components within the larger system as well as in the results they yield.

CONCEPT (BODY WITH REGIONS)

The studio's program was to design a mid-rise live/work tower for artists in the Lower East Side of Manhattan. The students were asked to develop systems that integrated important building parts from the very beginning in a feed-back driven design process. These parts were understood as “embryonic” information-bits that over time grew into fully functional buildings. The strategy was inspired by HOX genes, which determine geographic regions along the body-axis of organisms. Later these regions differentiate themselves morphologically and serve particular programmatic tasks. Some regions become highly specialized while others stay more generic. Genetic switches control the level of growth, size and specialization. The ‘Body with Regions’ describes an organization, which displays different intensities and characteristics according to its specific regions.

ANTHONY CAICCO, TODD COSTAIN, RYAN KEERNS, CHUCK NAWOJ: Beginning with biological examples with a particular filter toward architectural conditions, the project focused on the emphasis on structural variation and continuity. By utilizing methods of creating unstructured grids, several components were then deployed to create a variety of spatial types for this artist loft in Manhattan. The two towers took on differing roles as the floor-to-floor heights varied, then grafted together along the connections between the public vertical galleries.

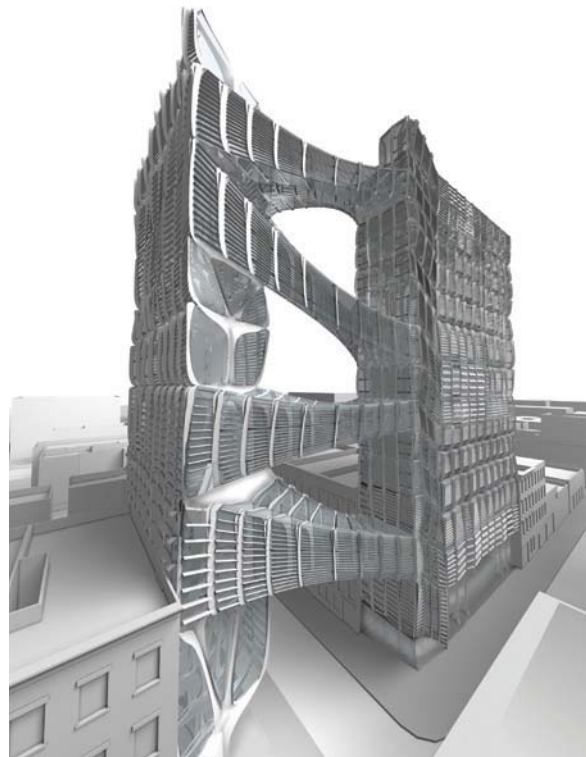
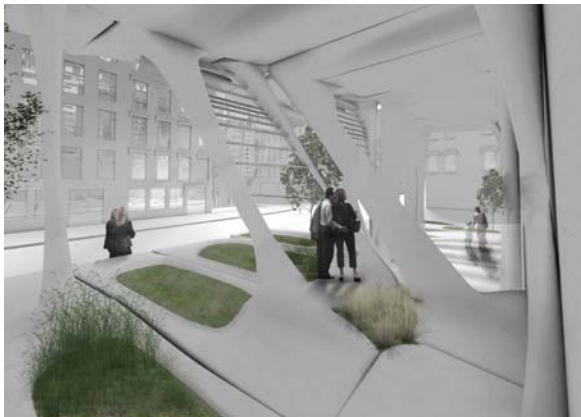

OPEN YET SECURE: INTEGRATING IDENTITY, SECURITY, AND DIPLOMACY IN THE DESIGN OF A U.S. EMBASSY

This studio developed a set of alternate visions to current embassy building practices. Beginning with the Vietnam War, magnified by the Beirut embassy bombing, and “hardened” by the events of 9/11, the current embassy building program has tried to symbolize American political and military power. The optimism, openness, and transparency of the post-World War II embassies have been replaced with a model of “embassy-as-fortress.” This studio addressed the social and political question, “Can America remain open yet secure?” Working with current post-9/11 embassy requirements in a site with a low/medium terrorist threat, each student offered an alternate vision to the current embassy model. The studio explored how new materials, technologies, and practices of integrative design could be deployed in the service of these alternatives.

The studio also explored new concepts for program organization and morphology of the U.S. embassy. Critical analysis of an embassy program can radicalize the building organization and morphology. At the site of an existing U.S. embassy under construction in Potsdamer Platz, Berlin, the studio provided a set of alternate visions. Each project integrated the particular constraints of the site with conceptual strategies, program organization, morphology, and integrated technology systems.

EXPOSURE

CARRIE BERGEY: Exposure attempts to embody the idea of the US Embassy in Berlin being “Open Yet Secure.” Foreign embassies are permanent diplomatic missions, in which a group of people from one state or government set up an office in another capital city or country. Often these permanent missions can be very dangerous leaving the peoples involved very vulnerable, dependent and exposed to the local conditions, local community, local infrastructure and local safety standards.

The word *exposure* is a device that allows for interpretation, expression and conversation. It communicates both the idea of vulnerability that the structure has to the environment, as well as, the vulnerability that the US has to the world. Exposure has very subjective implications regarding classification and secrecy from within the government nationally and internationally. Exposure speaks to threat levels of danger, such as terrorism, especially for the government employees working at the embassy. By setting values to Exposure, we can think about natural resources, security, public and private space, sunlight and vulnerability.

How to create a sense of place for the visitors and employees of an embassy that is securely protected and open to all?



SECTION DETAIL and ENVIRONMENTAL STRATEGY

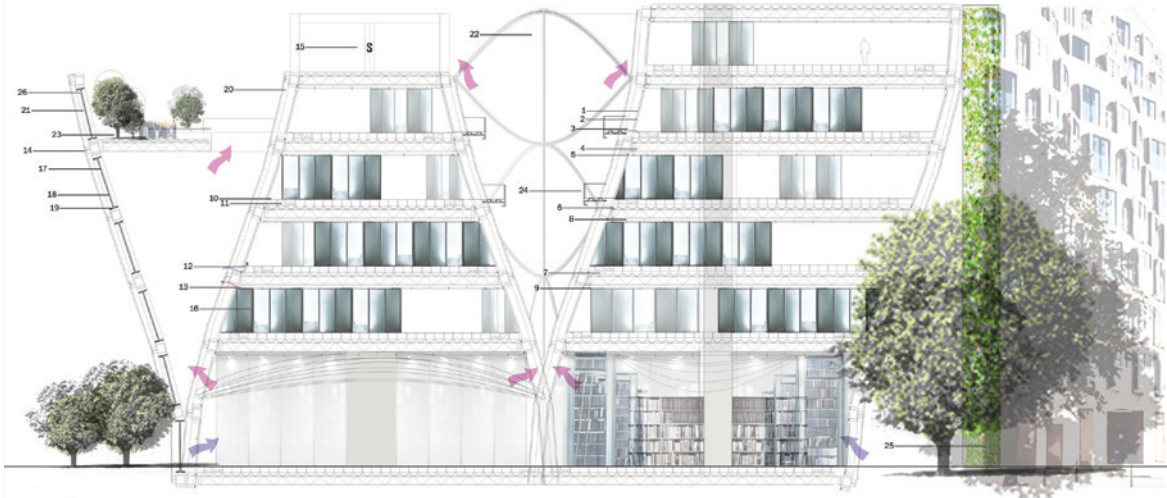

- 1. fixed double pane glass
- 2. steel frame
- 3. 20" steel beam
- 4. 24" w/ste beam
- 5. wire brush to stop dust
- 6. steel deck
- 7. concrete slab
- 8. sprinklers
- 9. drop ceiling

- 10. raised floor
- 11. HVAC
- 12. supply air
- 13. return air
- 14. steel fat spacer piece
- 15. helical wind turbine
- 16. glass partitions
- 17. acoustic facade
- 18. steel spring

- 19. steel cable
- 20. air cavity
- 21. acoustic cavity
- 22. atrium space
- 23. roof top deck
- 24. balcony
- 25. lay well
- 26. copper tubing to heat hot water



General Notes: This is a naturally ventilated building in the summer months and uses a heating system in the winter months. To offset the resources consumed in the winter, there are turbines on the roof to generate energy, as well as copper tubing to heat the hot water along the south facade of the building.

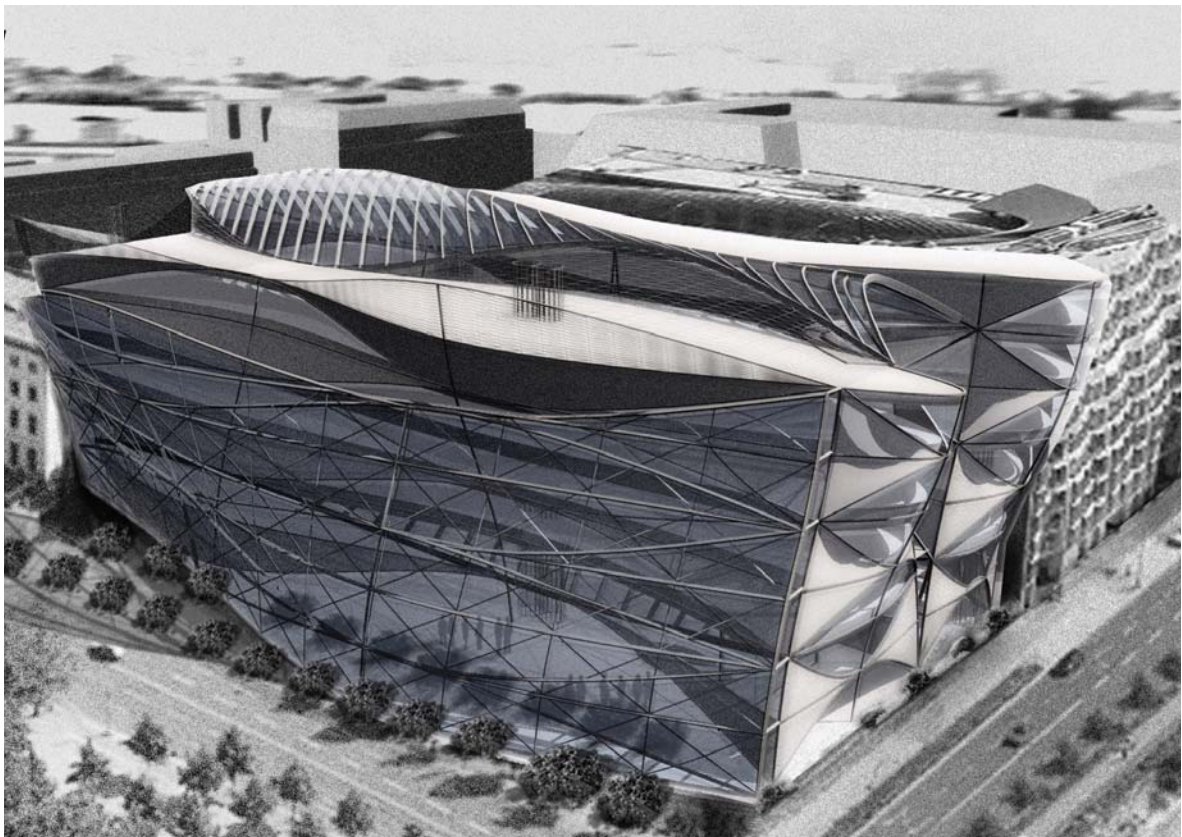

CONSTRUCTING ELEGANT ORGANIZATIONS: A HIGH-RISE FOR NEW YORK CITY

This studio examined emergence and its relation to the formulation of architecture by using digital techniques in an opportunistic fashion for the generation of growth and evaluation of patterns in the development of form. Digital techniques allow us to deal with the full complexity of material systems that lead to effects that are greater than the sum of their parts. *Elegant Organizations* looked for correspondence overlaps between locations, parities, and functions involved in their development. Elegant organizations are highly integrated formal/spatial systems which operate similar to organic systems in which the forms result from their adaptation to performance requirements; in our case the structure, inhabitable surfaces and enclosure. Achieving an integrated whole entails the refinement of spatial and structural organization and the integration of all building systems, [stairs, elevators, structure and skin] inflecting and adapting to each other, providing an overall intelligence of fabrication and assembly.

Our challenge was to go beyond surfaces and to elaborate structural systems that are compatible with an ambition for continuous differentiation in tall buildings. There already has been a brief history, where the structure itself provides for space as well as all the variation needed for the project. The next step in the development of organizations is on the envelope and the problem of how to tessellate or panelize continuously changing double-curved surfaces and, further, how to integrate openings. Naturally, on the way to the elaboration of fully functional, fully detailed designs, whereby more systems need to be integrated, the technique of inclusion becomes crucial to the development of tall buildings in variation. With a view to execution, further demands on geometry, precision and high-order surface continuity become paramount concerns. It was our challenge then to develop highly integrated models of structure and skin that are inter-related providing for a fabrication and assembly logic.

DANIEL HAMMERMAN AND KEVIN KEHLER: Inspired by the transformative process of rusting and ecological gradients of daylighting, our tower twists and modulates from a thin, flaky character to a sharp, solid condition as it rises from Battery Park City. Façade porosity varies in response to environmental simulations and incident solar calculations—becoming more open on the north face, while more enclosed on other elevations—and distribution of program is informed by interior daylighting levels. The concrete core, composite slab and complex lateral bracing are clad in Corian panels, which were thoroughly studied for curvature and seaming to delineate and accentuate continuity of flow from floor to wall to window mullions to ceiling.

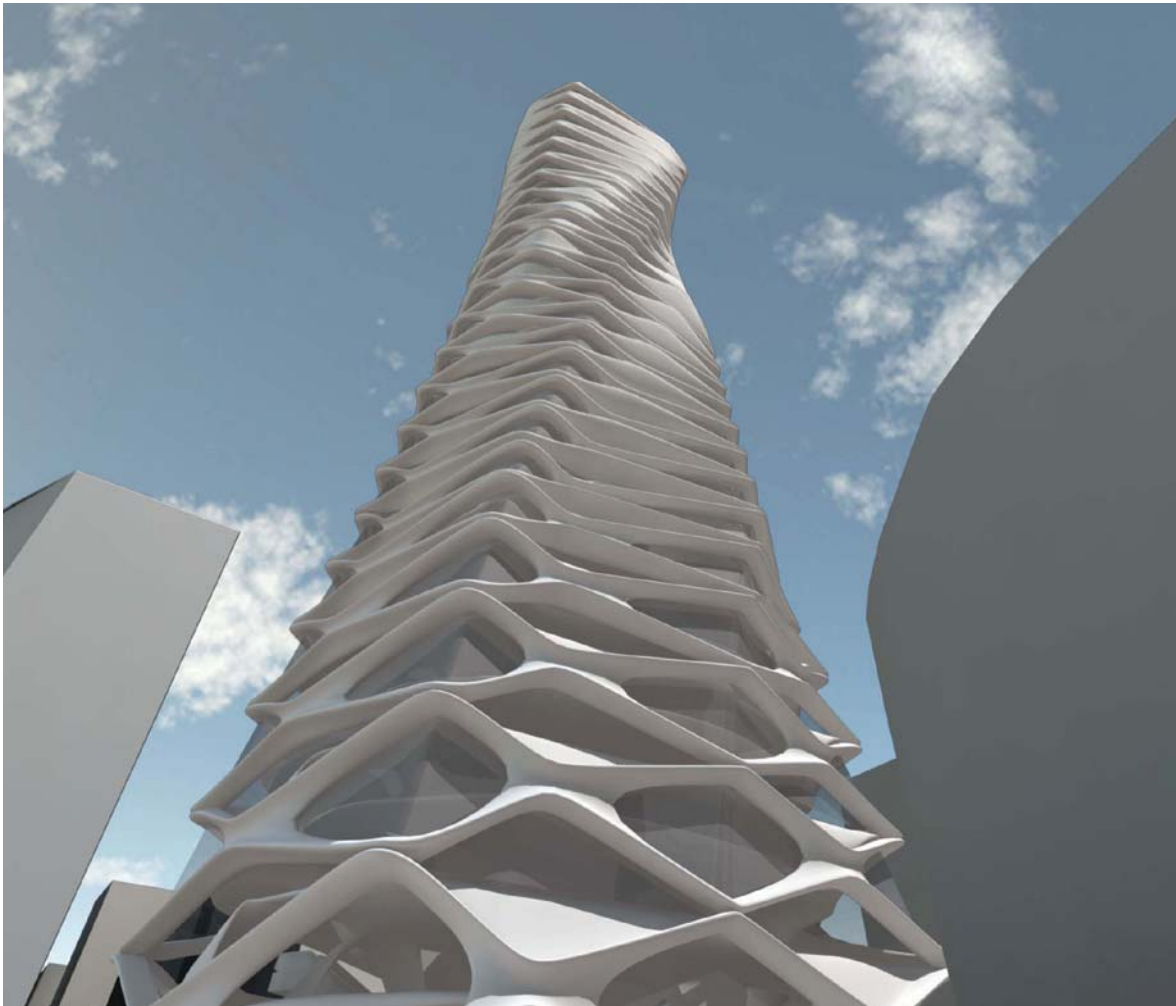

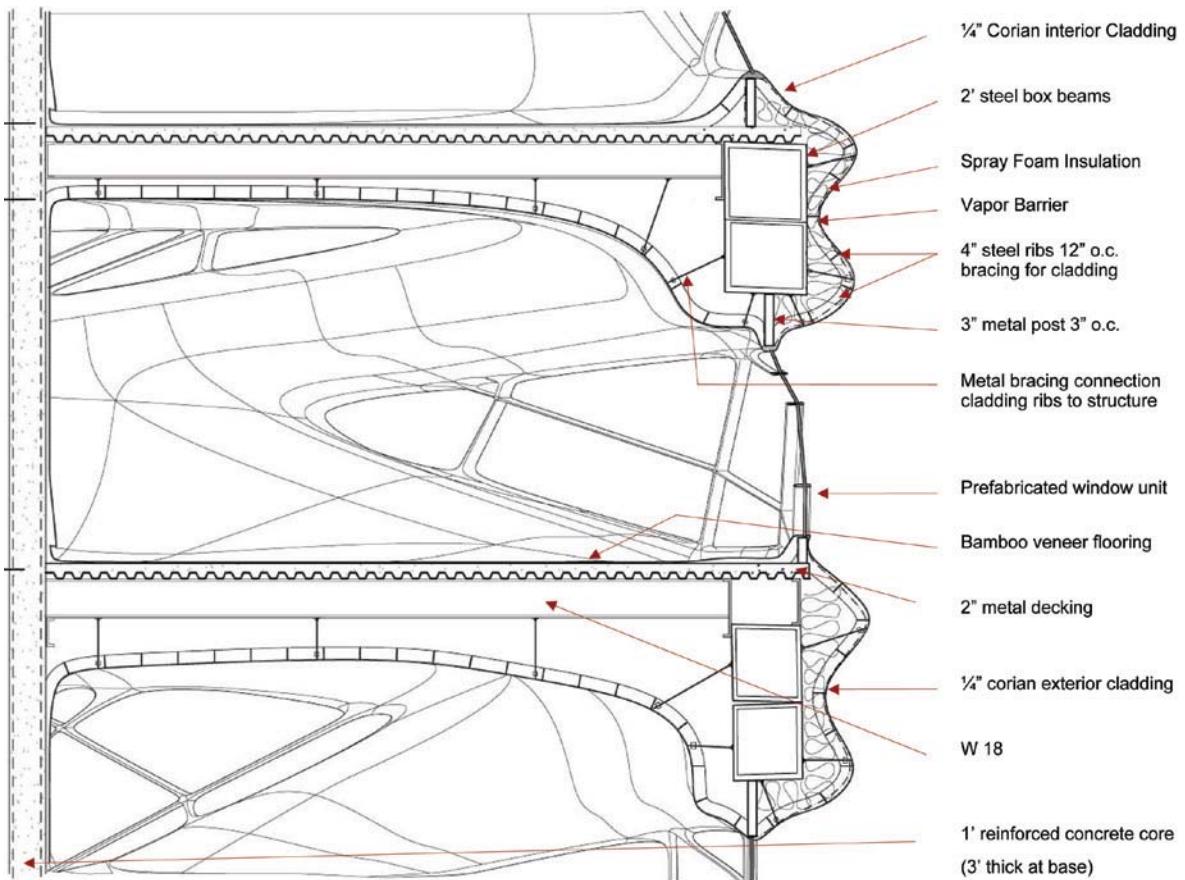
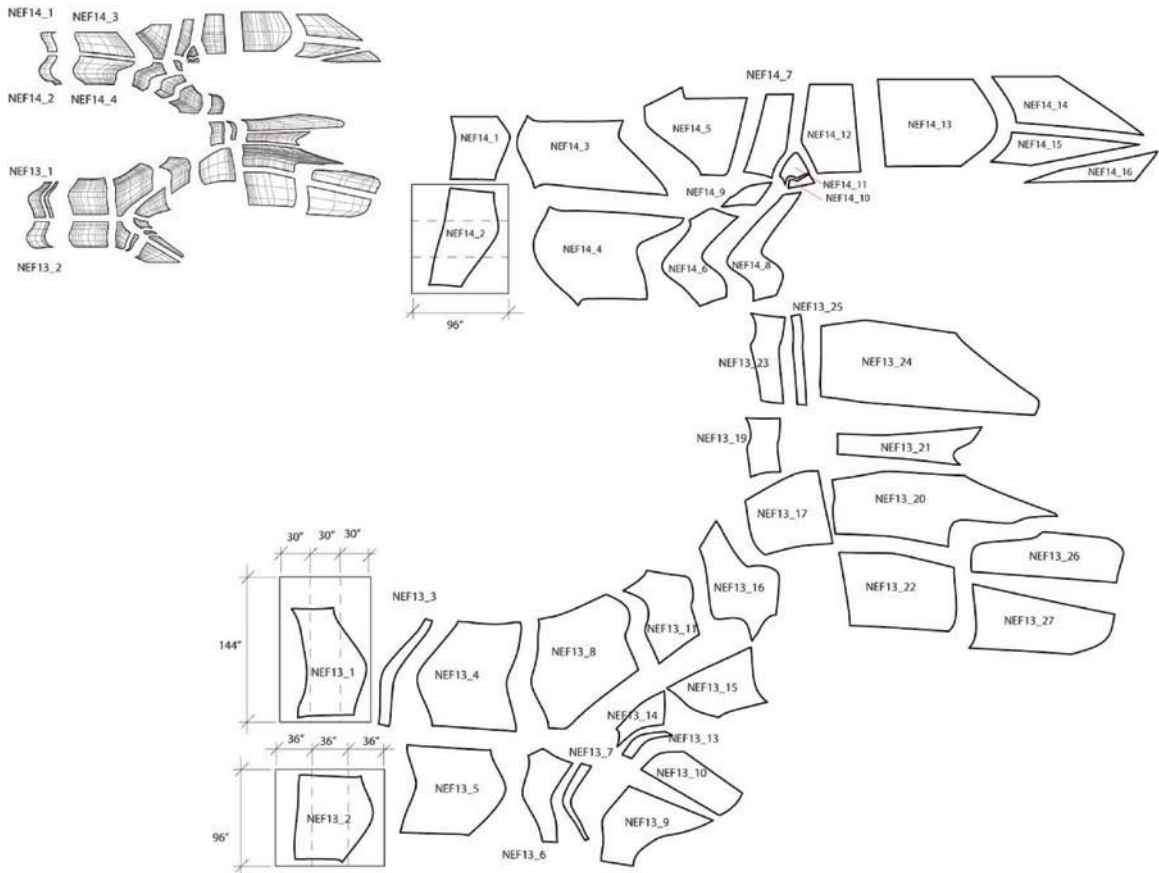

SENSATION—THEATRICAL EVENTS AND THE TIMELINESS OF AFFECT

Visual and spatial sensations are produced by and within environments that coordinate space with physical and or organizational structure, sight, sound and, in many cases, smell. These sensations are often deliberately sought after to induce everything from excitement to contemplation. Such diverse fields as entertainment, commerce, leisure and the recent phenomenon of housing have all exploited the positive effects of sensory enhanced spatial effects. The effects, which can range from the calm of a spa to the sensuousness and sumptuousness of a club or restaurant, become trademarked as desirable, leading toward, in the world of commerce, an exchange of goods, in the world of spectacle, an exchange of experience and emotion.

The field of architecture has often been described as a circus, complete with characters and both outlandish and heroic performances. However for the purposes of this studio the circus theme was used to further explore architecture as an instrument of sensation. To accomplish this, the studio analyzed and designed a Circus Arts Performance and Training Center which has been created for the New York Metropolitan area. In order to ensure the efficacy of design issues, extensive engineering research and workshops, a bibliography, organizational case studies, and containment space modeling were used to develop a basis for further exploration of the potential synergies between circus theatrics and architectural space.

JIN-KYU KANG: The project was derived from research conducted on the ring structure of a competition project by the Architects Sadar Vuga. The competition entry featured a structural ring that touched the ground at several points and supported the entire sports complex.

An important part of the research was the integrity of this rigid ring structure as it provided structural support and also its ability to house several programmatic needs. The existing landscape influenced the natural and organic shape of the ring while creating new topography. Several programmatic elements were housed within the ring and the overall envelope—bleachers for the sports facility, training classroom and performance halls.

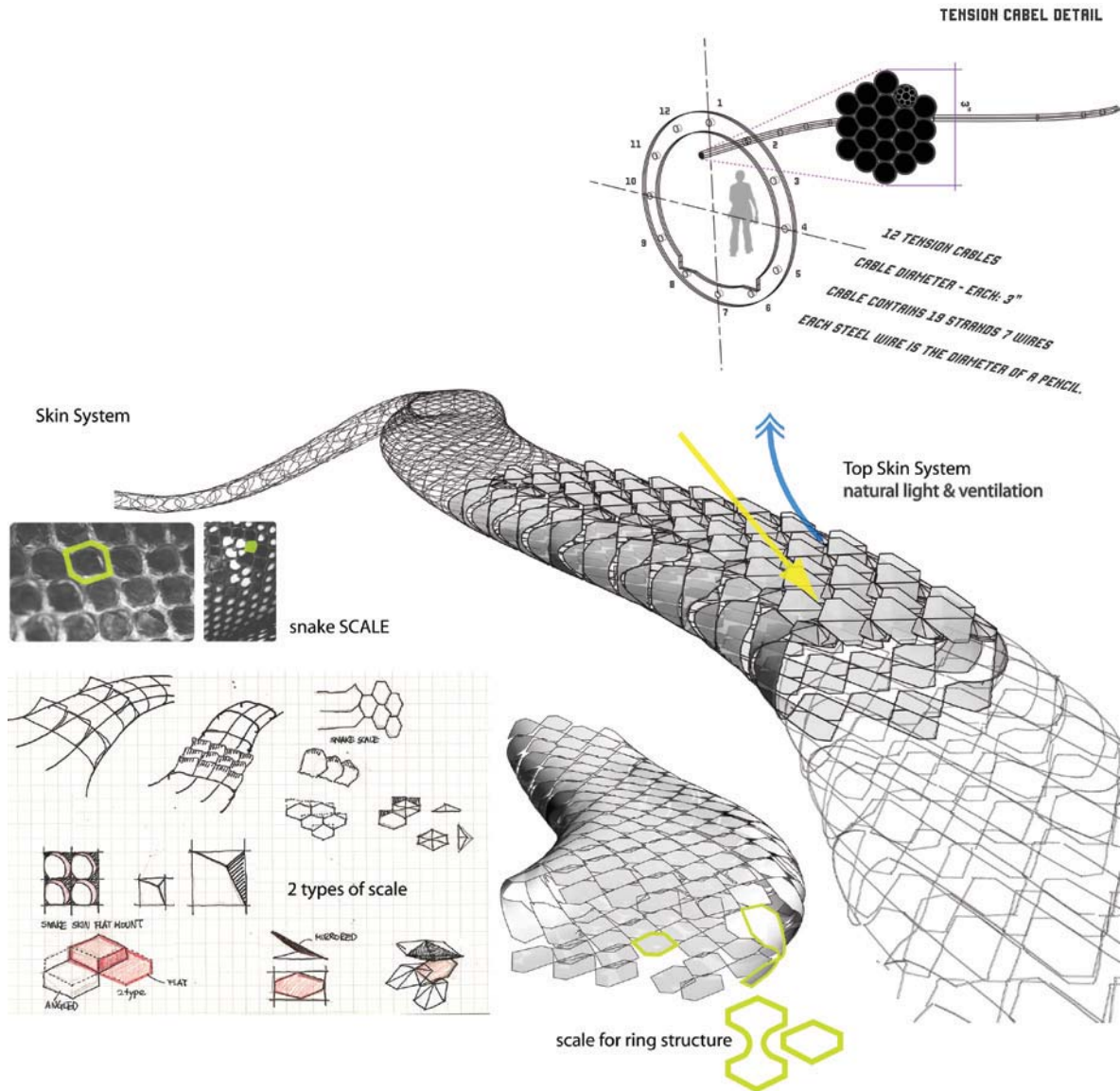

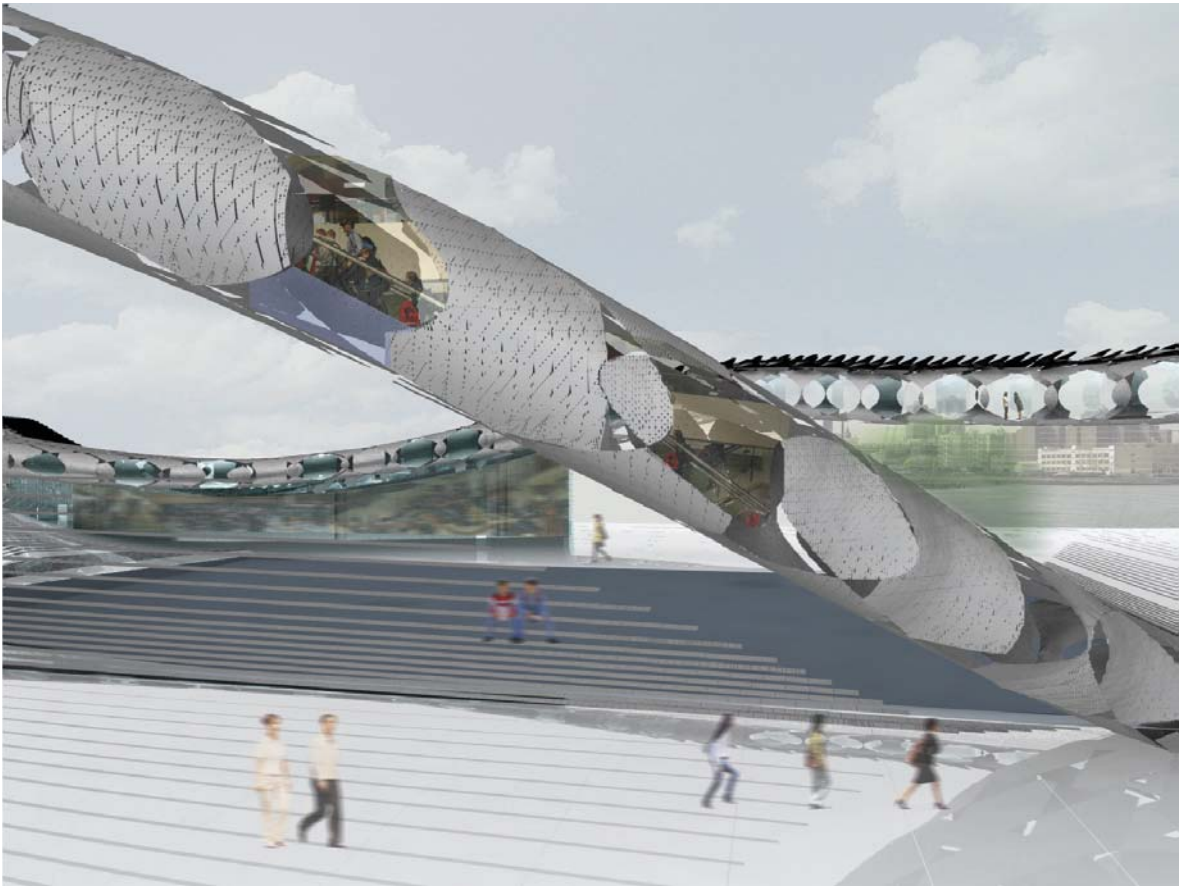

MULTIBODIES, AN INTEGRATION OF MANUFACTURED DESIRES

The oldest new idea in architecture—the prefabricated house—was the focus of this studio. As a possibility for architectural production, it has been simultaneously obvious and elusive, and despite a rich history of investigation, it remains an unfinished project. With escalating demands for housing, it may seem obvious to produce a house on the factory floor in mass quantities with material efficiency; it is not so obvious why you would desire it. Though the problem of prefabrication has been predominantly couched in modesty and scenarios of bare means, frustratingly the seductive possibilities seem to reside outside our economic rainbow. If houses were like cars, we would much rather live in a Ferrari than a Chevy.

When it comes to the home, our cultural obsession with individuality and the fulfillment of desire through ownership remain at odds with the evident pragmatic benefits of building on the factory floor. This is in marked contrast to how we feel about our cars, where there is a peculiar acceptance of models and brands despite the intense personal attachment we have with them. We studied the differences and the possible similarities between these two industries, and looked to invigorate the problem of the prefabricated home by asking to what degree the building of a home can become like the building of a car.

This studio set as a goal a radical integration of technologies to multiply possibilities for prefabricated architecture. Though the association of prefabrication with affordability has been a default assumption, projects will develop solutions at the high-end of production.

THE INHABITABLE SYSTEM

ROBERT MAY: In this investigation into the prefabricated home, a single, variable linear core genome negotiates the internal circulation and designation of systems, generating a range of typologies. The notion of ornamentation as customization drives the expression of the expanded core, as the structure of the digital framework derives the articulation of moments within the surface as they transition throughout the home.

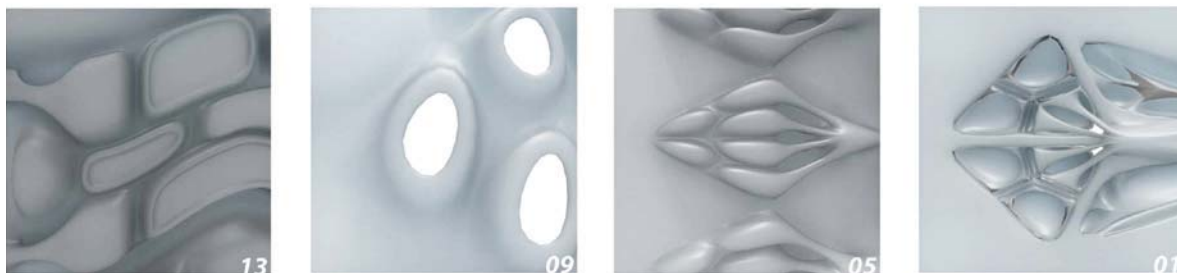
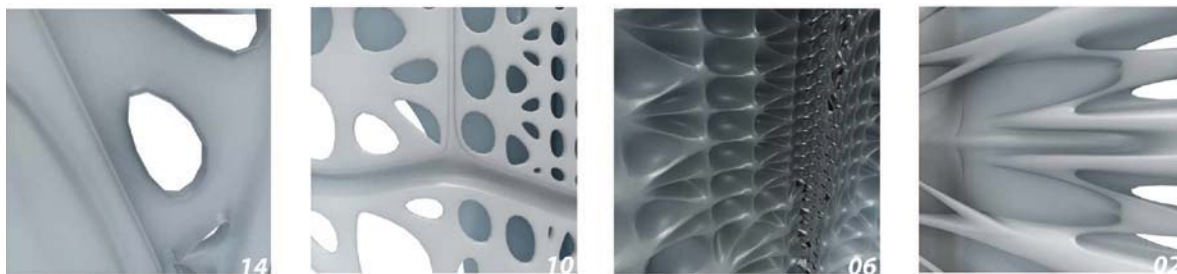
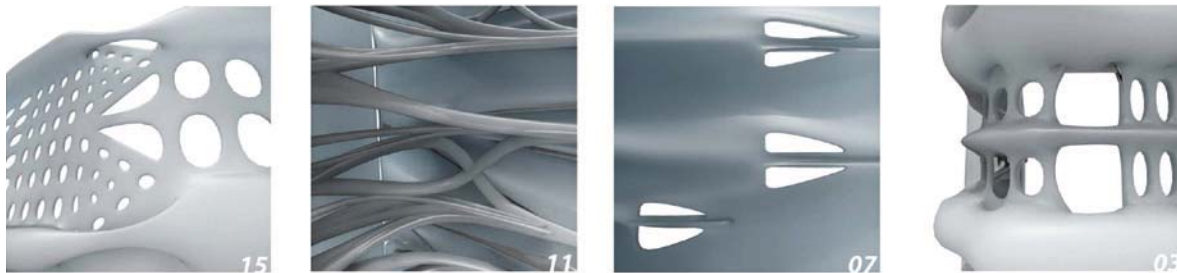
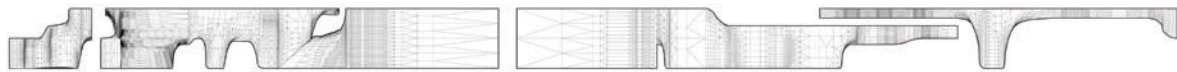

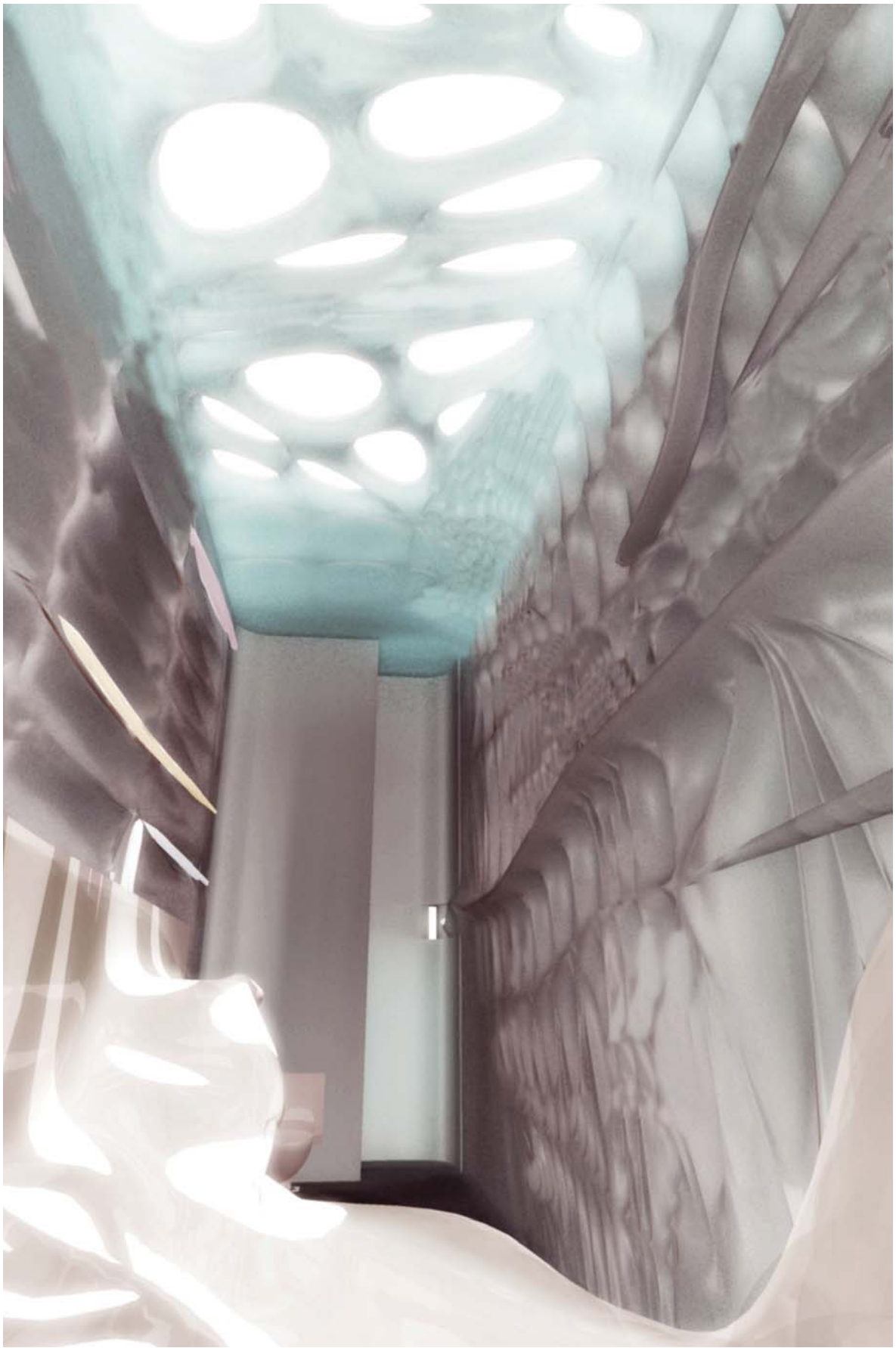

BORDERLANDS

The international border between the U.S. and Mexico, established in 1846, sharply bisects an ancient cultural and ecological region of great significance, especially in the adjacent areas of southern New Mexico, Texas, and the Mexican state of Chihuahua.

Economic and political conditions in the late twentieth century have created great disparities in wealth and culture, causing much cross border tension and making drugs and illegal immigration an enormous political issue in the U.S.

The studio addressed some of the profound issues of social and cultural histories and current differences and tensions in the region, as well as the significant ecological considerations for arid landscapes and building ecology. The program was a new facility for the North American Institute, a think tank and foundation established to address border issues and identities in the wake of NAFTA, including a museum, educational facilities, and housing. The site was near San Miguel, New Mexico and area of farms and bosques just north of El Paso, Texas. The studio traveled to the region to experience the site and cultures first-hand.

A POTENTIAL SHIFT: MEMORIES AND MOVEMENT

NOAH LEVY AND MORGAN MARTINSON: The Rio Grande River once meandered and flowed through a wide flood basin, depositing sediment, scouring banks, and shaping the landscape. The massive infrastructure of dams, levees, and reservoirs have channeled and confined the river, creating distinct zones of agriculture, housing, and degraded river ecologies.

"A Potential Shift" reshapes the levee walls that control the Rio Grande to weave zones and programs while introducing new relationships. Wetland ecologies meet community and public access, allowing for an expanded network of integrated elements. A museum and exhibition space offer views to ecological and social changes over time. During times of inundation, parts of the exhibition space become inaccessible. The material of the levee wall records flood marks and the river's past movements, while a traversing bike path allows for continuous movement along the memory of the previous levee wall. A housing community is situated across from the museum in a zone of nesting and sedimentations of the river flows. The two sides are connected by a footpath bridge.

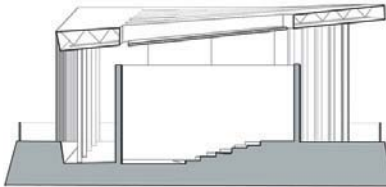

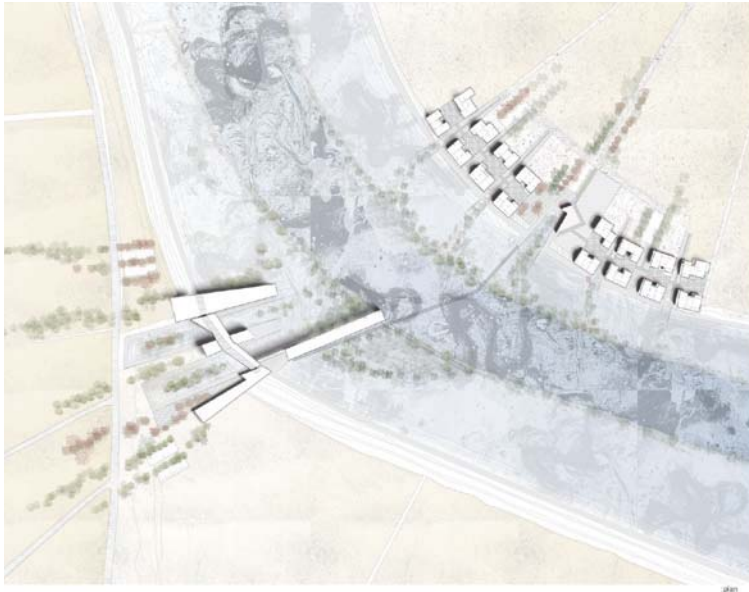

plan



viewing over ecologies



view from exterior walkway

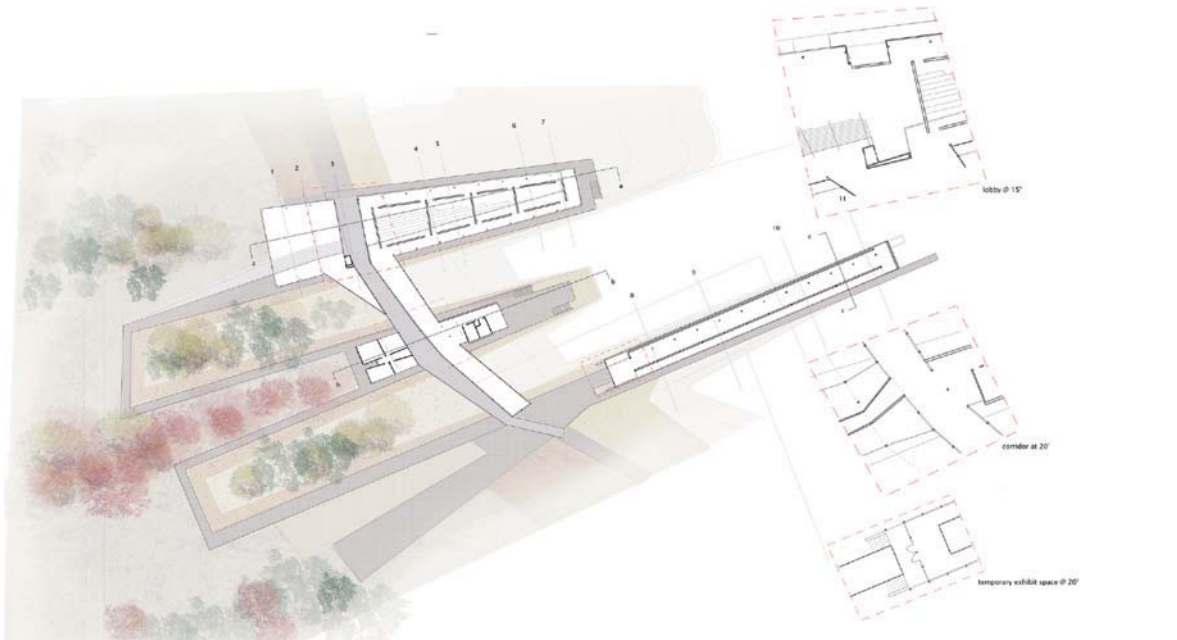
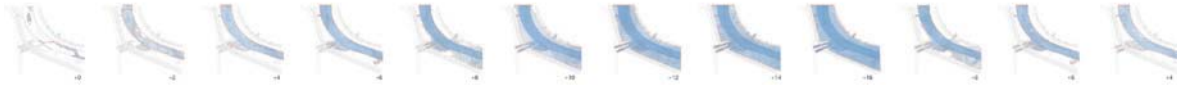

total plan



AA section

ARCH 701
DESIGN STUDIO V / ADVANCED ARCHITECTURAL DESIGN / DETLEF MERTINS, COORDINATOR

This is an elective studio at the advanced level in which each instructor develops their own pedagogical agenda and students choose from among these options.

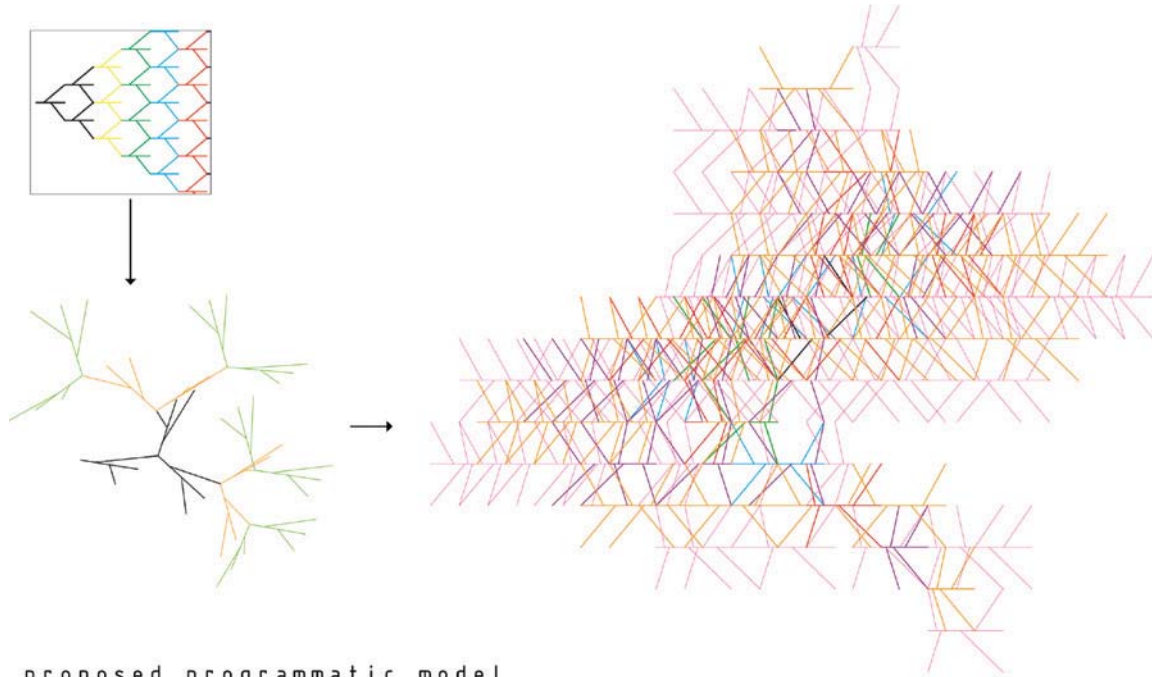

proposed programmatic model

tooling_ 3D x attachment angles

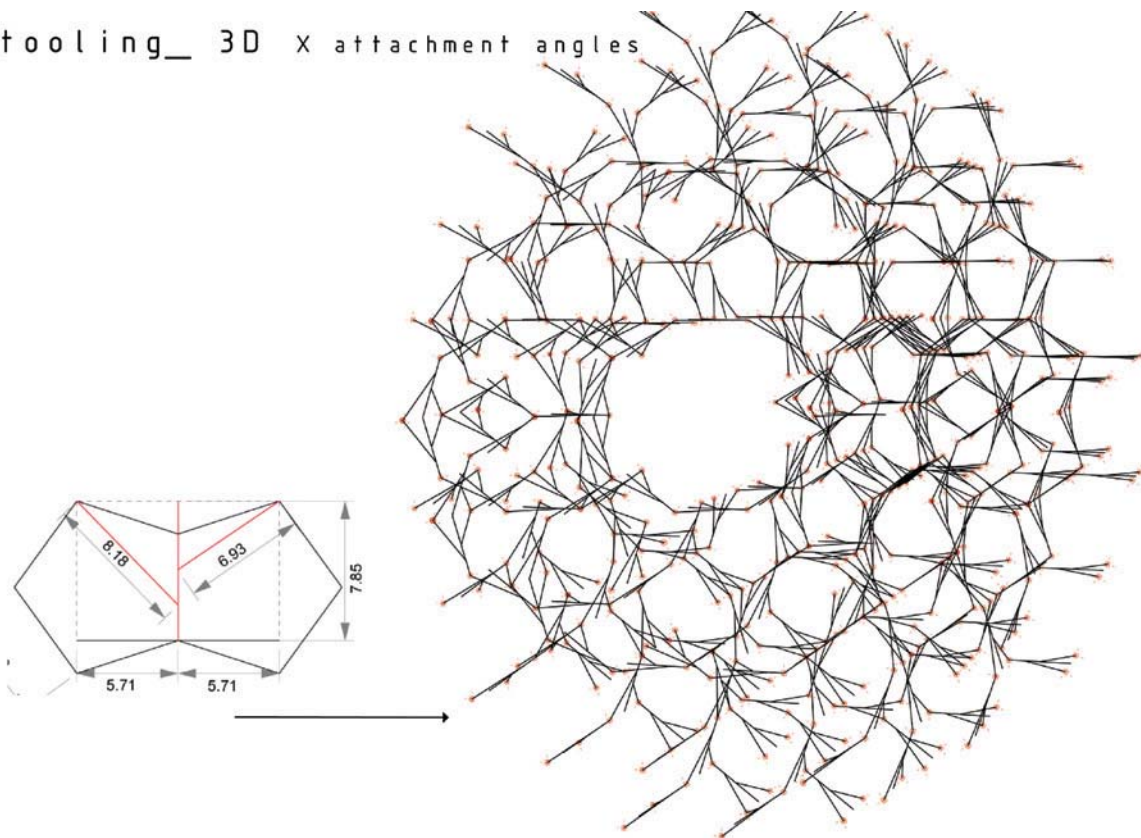

MAZES: RECIPES FOR GETTING LOST

The timing is now right to continue the legend of the maze into the 21st century. Mazes are patterned space to get lost in. While the notion that space/structure could be the direct result of pattern/procedure seems to stem from recent advances in architectural design aided by computation, when one looks at the history of the maze it is clear that this thickening of pattern to yield space has been its hallmark throughout the ages. Furthermore, the maze teaches us that the bare rationality of the labyrinthine circuit is a stepping-stone to the more allegorical, religious, and irrational themes impregnating space. Through strict geometrical procedure, set into relief by either garden or building landscape, the mind will find a way of getting lost. It is in this state of being lost that this studio responded to our culture's more-than-rational tendencies of searching, shopping, working and playing.

Our mazes build around our lust for getting lost. If the incessant use of Google is any indication, we are willing to get lost all the time. Searching through enormous amounts of information is as much about losing ourselves in the turns and dead-ends as it is about finding things. Which begs a question for architects: how will future architectures address this habit of getting lost? One way is to examine the architecture, both computational and spatial, of mazes. Wandering through a maze is the spatial equivalent of searching the web; both tasks can be modeled as *network transverse* problems. In fact, maze-solving algorithms are widely used on any data that is organized as a network, such as a telephone systems and databases, systematically traversing all paths and marking dead-ends to record the network's circuitry. In other words, the design process for making mazes can always be framed in parallel to the making of architecture at large.

MYSAPCE_SPACE

ISAAC CLAY COFFEY: Myspace, a Rupert Murdoch owned company, provides an interface for millions of users to engage social networking. While the company's website is a model for bottom up networking and enterprise, their own programmatic hierarchy contradicts their corporate mission. This project uses Generative Components as a tool to redesign MySpace's corporate structure by twisting a top down network into a highly distributed network of differing spatial adjacencies.

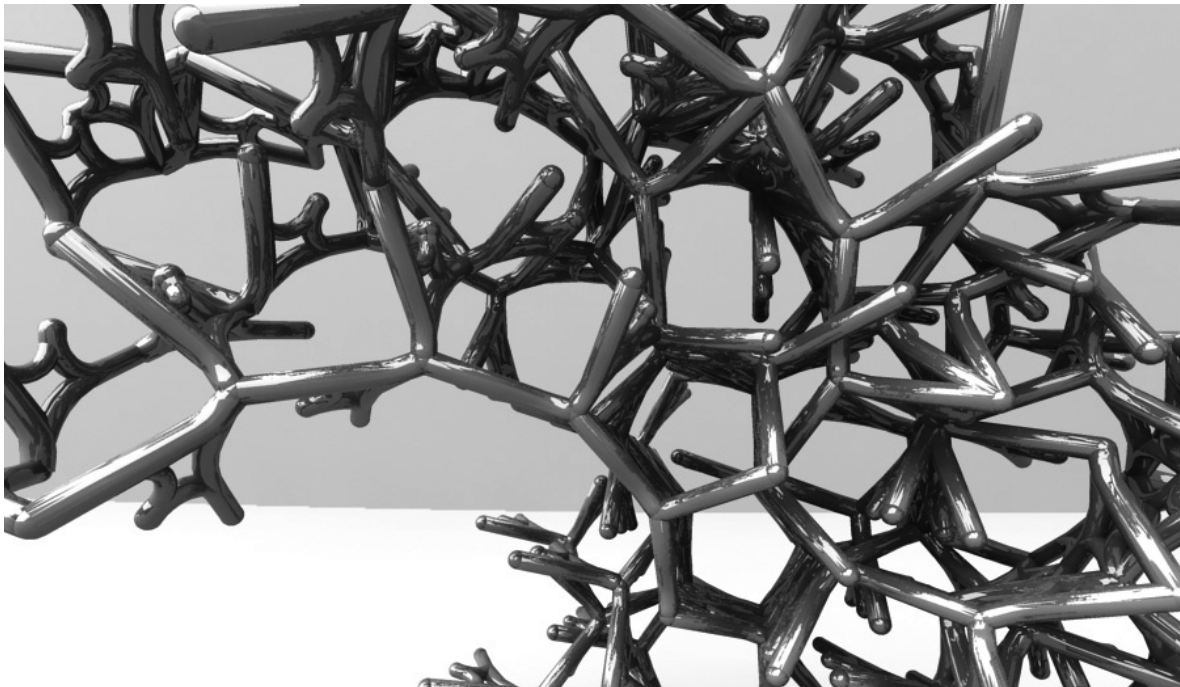
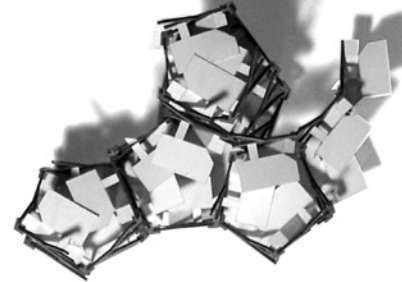

LONDON PROGRAM / THE MARKET: RANDOM PICKINGS—ERRAND CITY

Each year the London studio focuses on an aspect of London urbanism. The primary assumption is that the city in its historic development is a dynamic field where stability and change collide. While the historic fabric of the city is studied in the ways in which it has generated transformations, the studio finds methods and representations of this transformational field to generate new ways of describing physical and event based spaces.

One such site of continuous change in London can be found in urban markets. Though traditionally their functional contiguity with civic nodes has been primary, urban markets have always assumed a secondary role in the representations of city life. They chart the unstable spaces of exchange of goods and labour on the margins of infrastructure. There is an appropriated, negotiated space and not a fixed territory. They demarcate temporary domains of social and economic mobility, ebbs and flows of transitory populations in the city entering the fray and maintaining their right to be against the grain, below the horizon, before the norm. Often what comes to be known as a famous London market is result of a series of unplanned, unwarranted urban contiguities where catalyzers such as cheap rent, disused land or undervalued real estate, often contiguous with infrastructure, offer opportunistic momentum for a transitional occupation. Having developed primarily as a spaces of commerce, one could argue markets at once enable and erode much of what is planned in the city. From the designated space of distribution centres to the negotiated territory of the street markets, the space of markets in London was the focus of our study in this studio.

The studio used video, photography and drawing machines to analyze events around specific London markets. The cut, as a plan or section, poses one thing next to another, it operates surgically to see the inside relationship of parts, contiguities of historical sites and their architecture. On the other hand dynamic temporal conditions charted by flow, speed, and spatialities of encounter tell of the event. The time in the market is not simply functional and linear but is also peripathetic and motivated by desire. Whether we think of studying the architecture of the city to be a scientific task or an aesthetic search, whether a matter of functionality or performative exchange, the cut and the flow take on new forms and provide a frame to study Architecture of the city and the nomadic spaces of its markets.

JONATHAN SIM: 'Marketscape' involved understanding the urban characteristic of London's city fabric. This particular investigation sought to design a drawing machine that could "illustrate" and form an atlas of details and intricacies that define Borough Market and allows for survival and function within London's "junk spaces". The design of the drawing machine sought to capture a pulse data of the city and reinterpret the marketscape as it exists through another perspective. The Drawing Machine ultimately captures movement through interpretations of sound intensities at specific moments of bifurcation within the marketscape. Existing as a space "between" the city's infrastructure, sandwiched by overhead rail lines and the city surrounding the perimeter, Borough Market takes a particular form. The emergent network of sound results in the creation of an atlas of the marketscape geography.

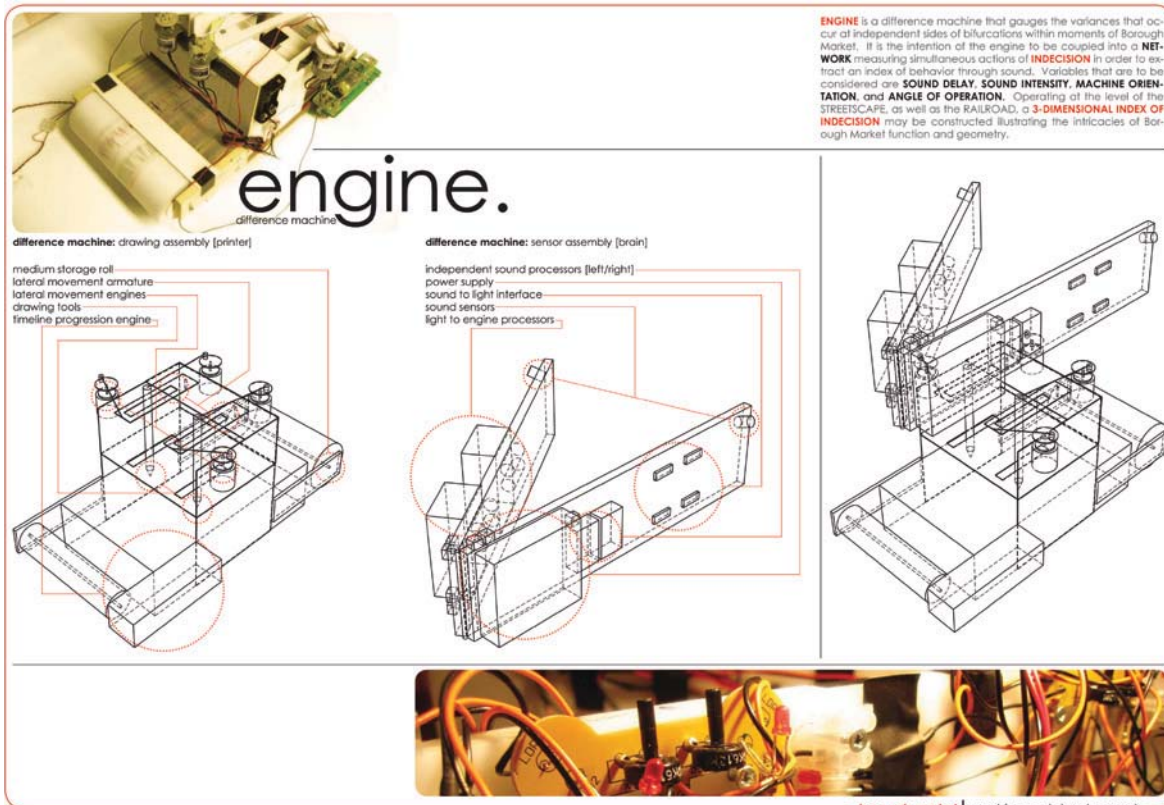

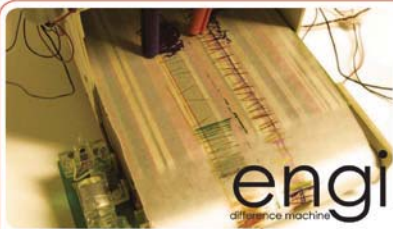

engine.

difference machine

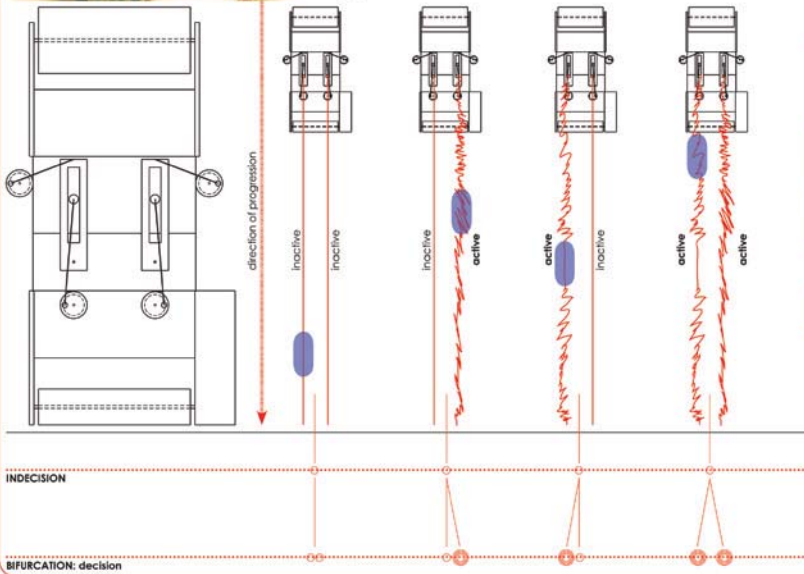

ENGINE is a difference machine that gauges the variances that occur at independent sides of bifurcations within moments of Borough Market. It is the intention of the engine to be coupled into a **NETWORK** measuring simultaneous actions of **INDECISION** in order to extract an index of behavior through sound. Variables that are to be considered are **SOUND DELAY**, **SOUND INTENSITY**, **MACHINE ORIENTATION** and **ANGLE OF OPERATION**. Operating at the level of the **STREETSCAPE**, as well as the **RAILROAD**, a **3-DIMENSIONAL INDEX OF INDECISION** may be constructed illustrating the intricacies of Borough Market function and geometry.



output algorithm

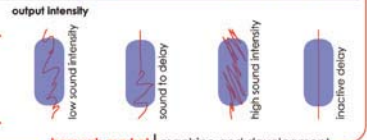

borough market | machine and development

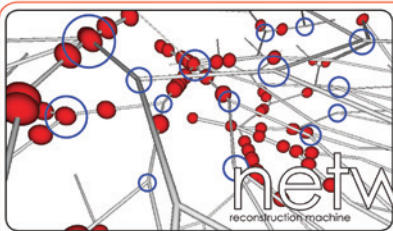

network.

reconstruction machine

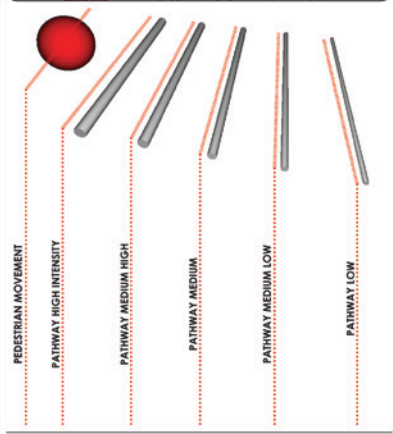

NETWORK INDEX
nodes of indecision ○
path of progression —

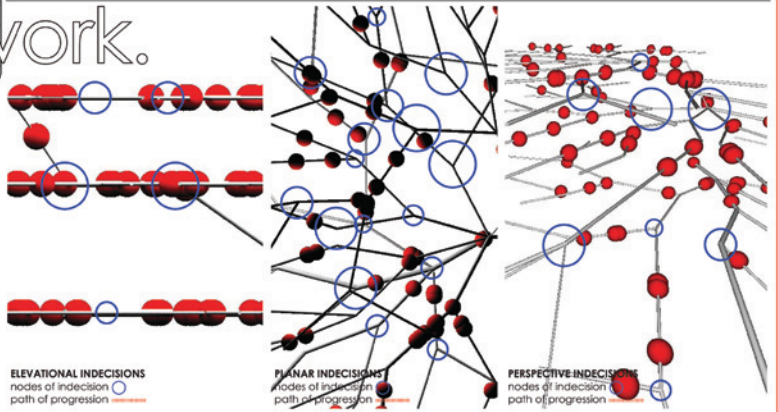

borough market | machine and development

SYMBIONIC RESORT

The idea of resorts originated in the fifties when Gerard Blitz recognized the need for a unique escape from the hardships of postwar Europe. With the first all-inclusive vacation on the exotic island of Mallorca, Club Med was born. Over the years resort designs experienced multiple conceptual and stylistic transformations, but always used nature as its ultimate asset. Resorts have harvested natural equity through positioning themselves in the middle of it, with more or less strong engagement with the environment. Today nature is becoming rarer than ever and needs to be protected wherever possible, but the desire to travel and experience extraordinary environments is not going away soon.

WHY NOT DEVELOP OUR OWN NATURE?

Bionics is considered one of the key inspirational resources for technical innovations globally. In architecture, observations of nature and thoughts about its technical applications have been investigated for hundreds of years. One potential that is not fully unfolded (and partially dismissed because of pseudo organic design) is the transfer of aesthetic equity of nature to innovate spatial, experiential and visual concepts.

AESTHETIC EQUITY OF NATURE + ABSTRACTION = SYMBIONIC

The Symbiotic Studio had as its goal the development of resorts that transfer not just technology between nature and synthetic construction, but also aesthetic, spatial and experiential concepts, which mimic the original very closely or surpass it. The intentional copying of examples from natural organisms and ecologies treats nature itself as a database of solutions and as a raw model for aesthetic formation. To further accelerate the discourse, the symbiotic resort was situated in environmentally or economically challenged environments in and around Philadelphia, and needed to unfold self-sufficient scenographic equity and kick-start an environmental renewal process within that context.

AMY CAMPBELL, JACKIE WONG: "Genergy" proposes to capture the energy produced by extreme athletes during their athletic pursuits to maximize the resort's self-sustainability. Programmatic necessities and the utilization of rock formations as visual, spatial, and experiential inspirations drive the architectural form at Genergy.

The gym building is enclosed by a half-mile running track that mimics different treadmill patterns to allow each athlete to choose the type and difficulty of the preferred track. The visual and spatial continuity inside the gym allows athletes to incentivize each other during their workouts.

The form of the spa building is informed by a rock climbing wall that doubles as the skin of the building and its structural components. Athletes climb up to the top, cool off in the rooftop pool, and proceed into the main lobby. They then traverse a series of spa spaces that allows the body to decompress and rejuvenate after a strenuous workout.



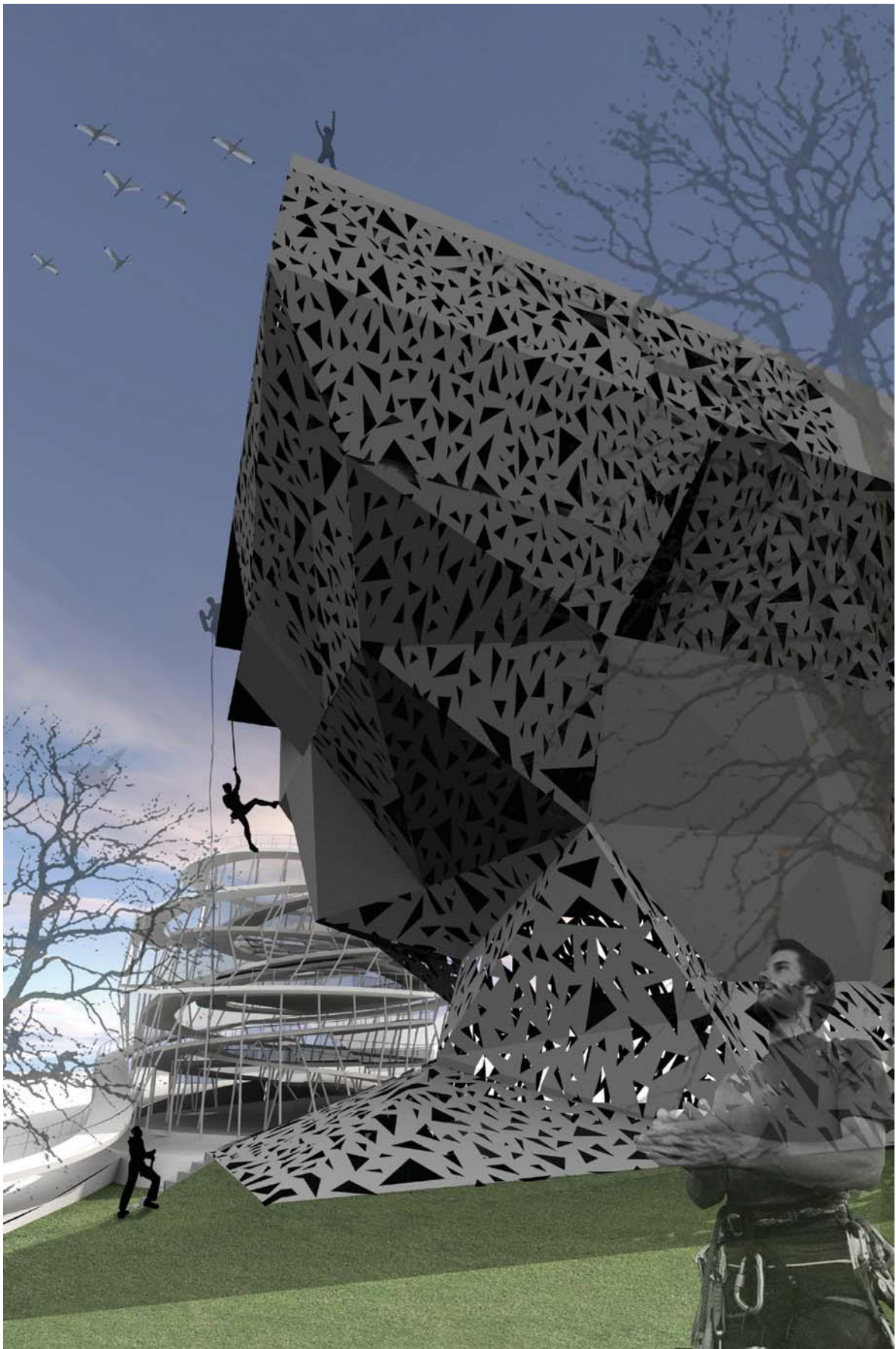

PROPAGANDA/NEGOTIATION: MULTIPLE EXPOSURE ARCHITECTURE

News dissemination worldwide is facing a crisis—a crisis that echoes political conflict across the spectrum of left and right. Journalistic neutrality has eroded and increasingly, media outlets are blurring the distinction between reporting and editorializing, presenting viewpoint as truth, erasing the traditional separation of fact and opinion.

The techniques of propaganda are both overt and covert and involve not solely the message content but its physical presentation as well. Through systematic techniques propaganda eradicates the presentation of opposing or contradictory view. The exchange of facts between media and receiver is no longer equal but is imbalanced to the brink of unbalanced. Currently, controversial networks such as Fox and Al Jazeera have been accused of presenting the agenda of controlling parties as factual certainty.

Conversely, the United Nations, by its very nature, is a 'neutral' agency. Its authority is derived from the willingness of each individual member nation to defer their power to the collective to achieve the aims expressed in the U.N.'s charter—the propagation of peace, the resolution of conflict and the affirmation of human equality. By recognizing the U.N., the members agree to set aside their authority for that of the U.N. as one negotiating body. Equilibrium is ensured by the cooperation of all; each member benefits from equal exchange as defined in the U.N. charter. The goal of the U.N. therefore, is to be balanced in all issues and agendas it negotiates.

In actuality, negotiation is an asymmetrical relationship in which there is not an absolute equality among the agents involved at any one moment. The process of negotiation is a constant shifting of reciprocity between agents.

The studio critiqued the methods of propaganda and the process of negotiation. The experiment of the studio was to create an open-ended dialogue between propaganda and negotiation, using architecture as a medium. Students developed independent programs with propositions on one of three sites in New York City.

PETER RAE: The U.N. ICT (Information and Communication Technology) Exchange will house the U.N. ICT task force as well as host motivated participants of the micro credit system who are eager to expand their knowledge of existing as well as new technologies relevant to social business. The population of participants is largely made up of women and will infuse Wall Street with a socially minded, mostly feminine presence encouraging interaction between the two currently polarized worlds.



KIVA MICRO LENDER

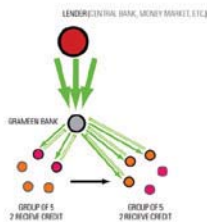

GRAMEEN BANK MICRO LENDER

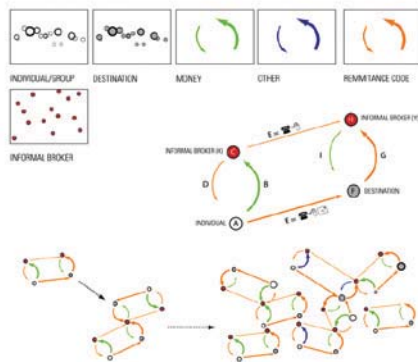

INFORMAL VALUE TRANSFER SYSTEMS

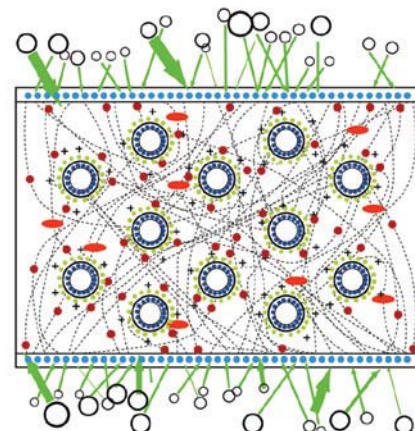
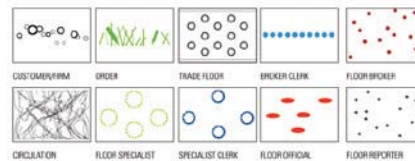

NEW YORK STOCK EXCHANGE TRADE FLOOR

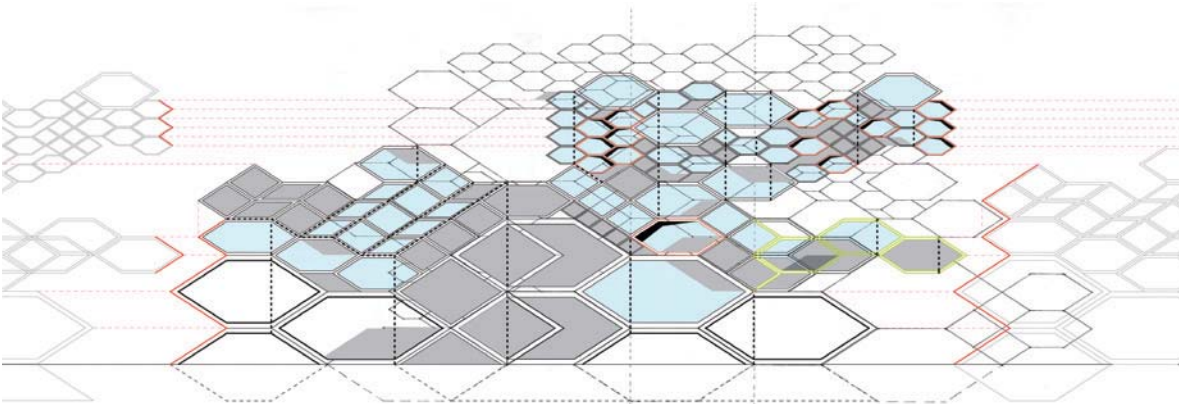
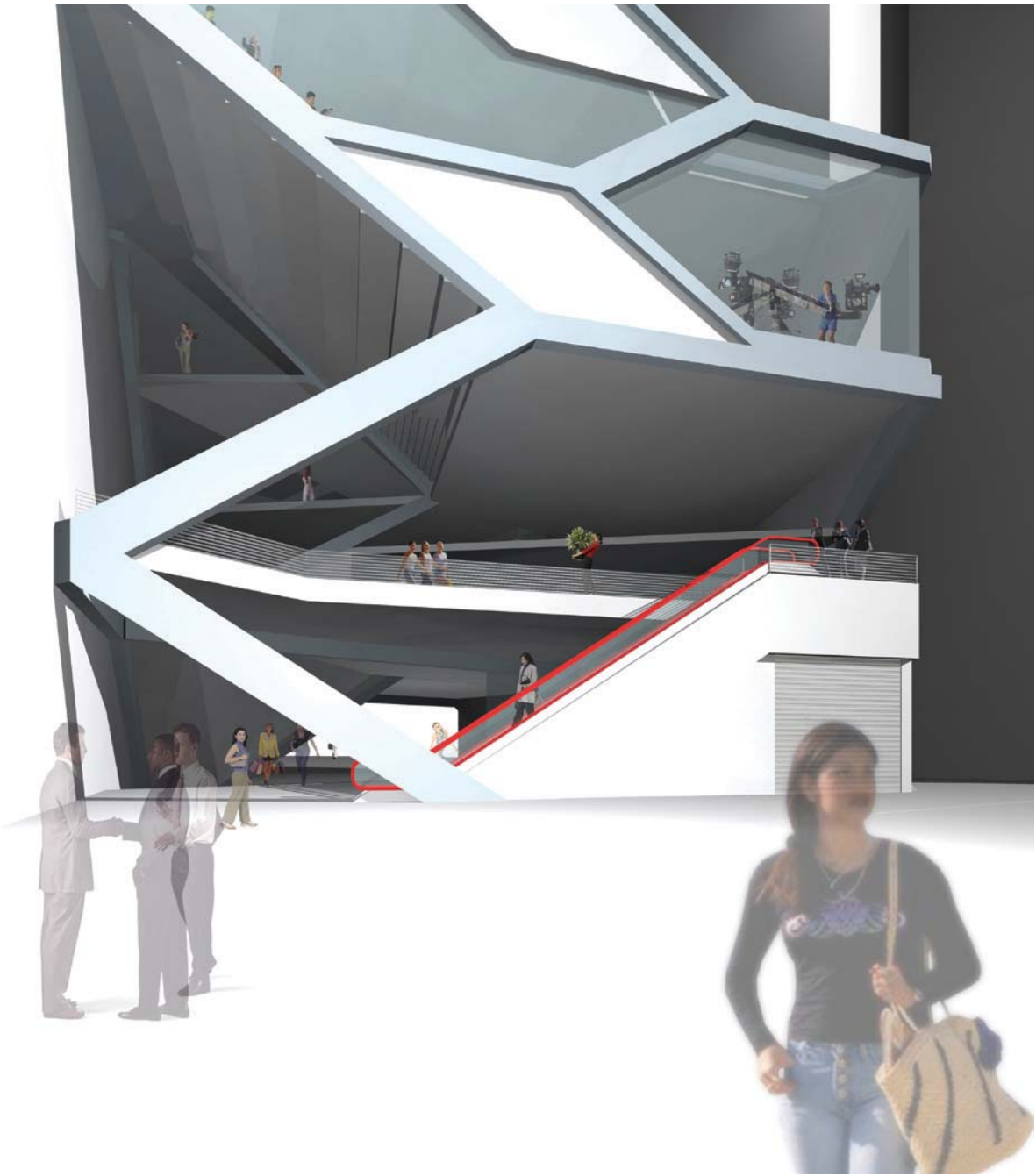

The goal of this studio was to replace Pont Saint Louis (mainly for pedestrians, cyclists, and street performers) that bridges the Seine, located in Paris between Ile de la Cité and Ile Saint Louis; secondly, replace the Seine river ferry bus (Batobus) stop pavilions (ticket office, waiting room, café) with a deployable structure and skin that changes seasonally.

In order for each student to develop some skill and knowledge of advanced systems of structures and skins, the following technological themes were examined: structural glass, tensile steel and carbon fiber systems, layered thermal skins, shapes or configurations (structure and/or skin) that change in response to environmental and/or programmatic changes.

In addition to issues derived from the program, site, structure, construction, materials, heat and light etc., our discussions and criticism took the systemic form that considers: physics (vector analysis of all flow patterns); poetics (rhythmic patterns of joints of structure, construction and visual geometry); the essence of the archetype (from which the cases are derived); and the aesthetics of beauty (the configurations states of equilibrium, mechanical and visual) and the sublime (experiences that are beyond the human threshold).

JOHN ANDRUS: PONT SAINT LOUIS

The essence of this project is the blending of a prominent structural solution with architectural space. The king post is typically the compression member that mediates between a compression beam and a reacting tension member. The solution aims to occupy the king post, maintain a slender and simple elevation, and direct pedestrian and bike flow to performance spaces with multiple lanes of travel.

BATOBUS PAVILION

The pavilion responds to the sun's path by yielding multiple variations in accommodating solar conditions throughout the year. One reason for faceting the form of the pavilion is to have viewing planes perpendicular to major views up, down and directly across the river. The essential design variables of the pavilion's waiting room are orientation; light, heating and cooling; view and the appropriate geometry.

Batobus Pavillion

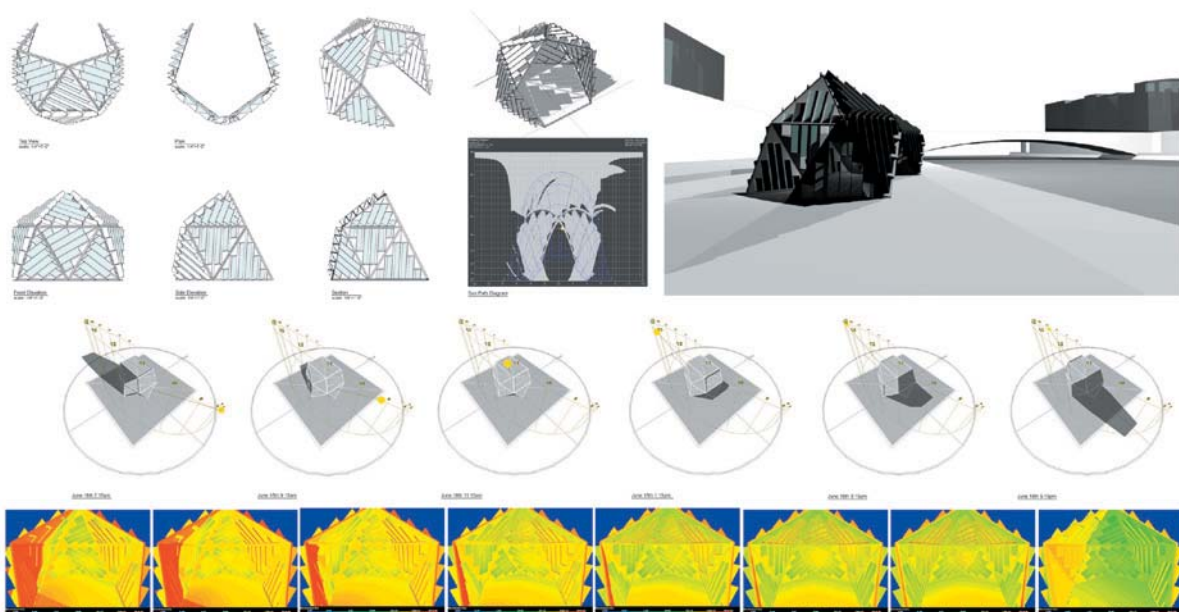

Poetics

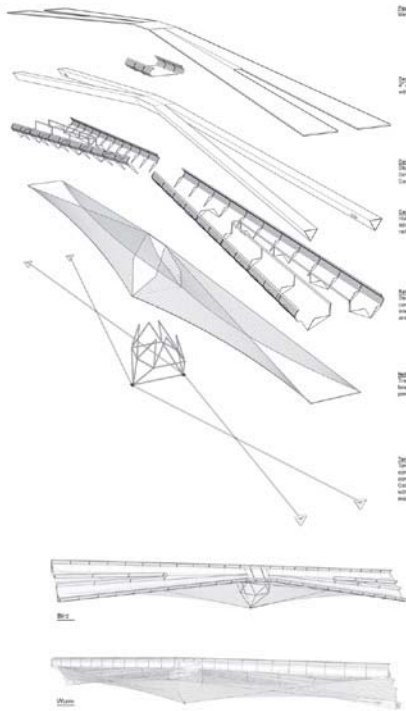

Details

Deck
The deck is a composite structure consisting of a steel truss and a concrete slab. The truss is made of steel tubes and is supported by a concrete slab. The deck is supported by a steel truss and a concrete slab.

Deck
The deck is a composite structure consisting of a steel truss and a concrete slab. The truss is made of steel tubes and is supported by a concrete slab. The deck is supported by a steel truss and a concrete slab.

Compression Beam
The compression beam is a steel tube that is supported by a concrete slab. The beam is supported by a steel truss and a concrete slab.

Compression Beam
The compression beam is a steel tube that is supported by a concrete slab. The beam is supported by a steel truss and a concrete slab.

Truss
The truss is a steel structure that is supported by a concrete slab. The truss is made of steel tubes and is supported by a concrete slab.

Truss
The truss is a steel structure that is supported by a concrete slab. The truss is made of steel tubes and is supported by a concrete slab.

Truss
The truss is a steel structure that is supported by a concrete slab. The truss is made of steel tubes and is supported by a concrete slab.

Truss
The truss is a steel structure that is supported by a concrete slab. The truss is made of steel tubes and is supported by a concrete slab.

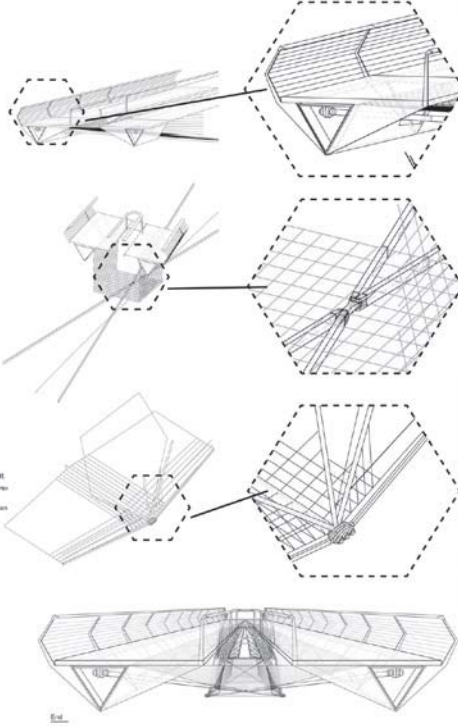

Materials

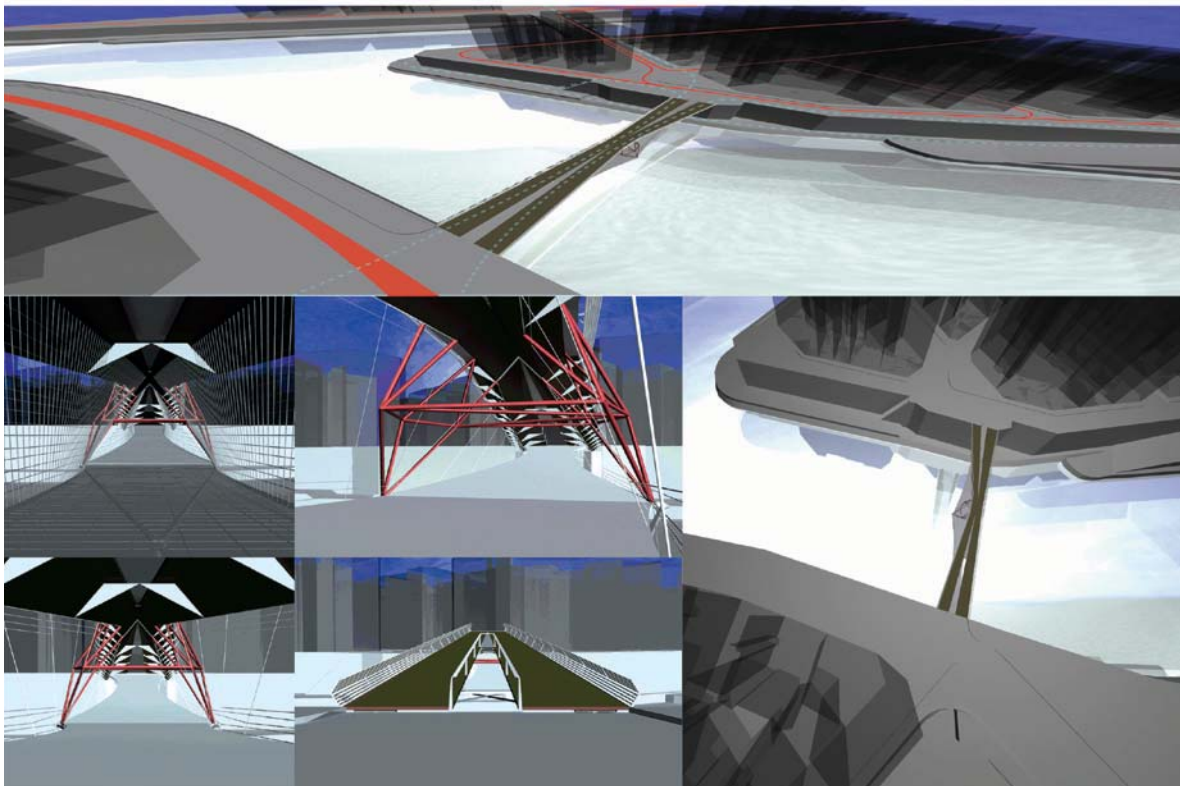

THE CENTER FOR THE INDIGENOUS ARTS, MEXICO CITY, MEXICO

This studio challenged students to design a new Cultural Institution in one of the most dynamic and significant urban contexts existing today. Mexico City can be easily classified as a *megalopolis*, on the level of Tokyo, New York City, Seoul and São Paulo as the 5 most populated metropolitan regions in the world. Working in the Mexico City context provided the opportunity for fantastic urban projects to occur as well as significant public critique. Issues of urban density & infill, contested sites, and development strategies will be addressed in the final resolution of each project. Additionally, students were asked to develop a larger urban framework in which future interventions may occur, represented through urban spaces, architecture and restoration projects in the area around the Zocalo and the Colonial fabric nearby. Their projects acted as new precedents for future interventions in the historic core. These strategies built upon the varied civic functions which the city center already supports and will investigate the challenge of building new in a historic context.

BUM-JOON KIM, CONSTANCE KIM, HAROLD KWON: This holistic architectural project is aimed at alleviating the pressure from a water crisis in Mexico City, where groundwater is significantly overexploited. The proposal includes enhancing the infiltration of rain water throughout the public infrastructure, implementing roof catchments on the existing buildings, and further examining new opportunities to generate valuable spatial layers.

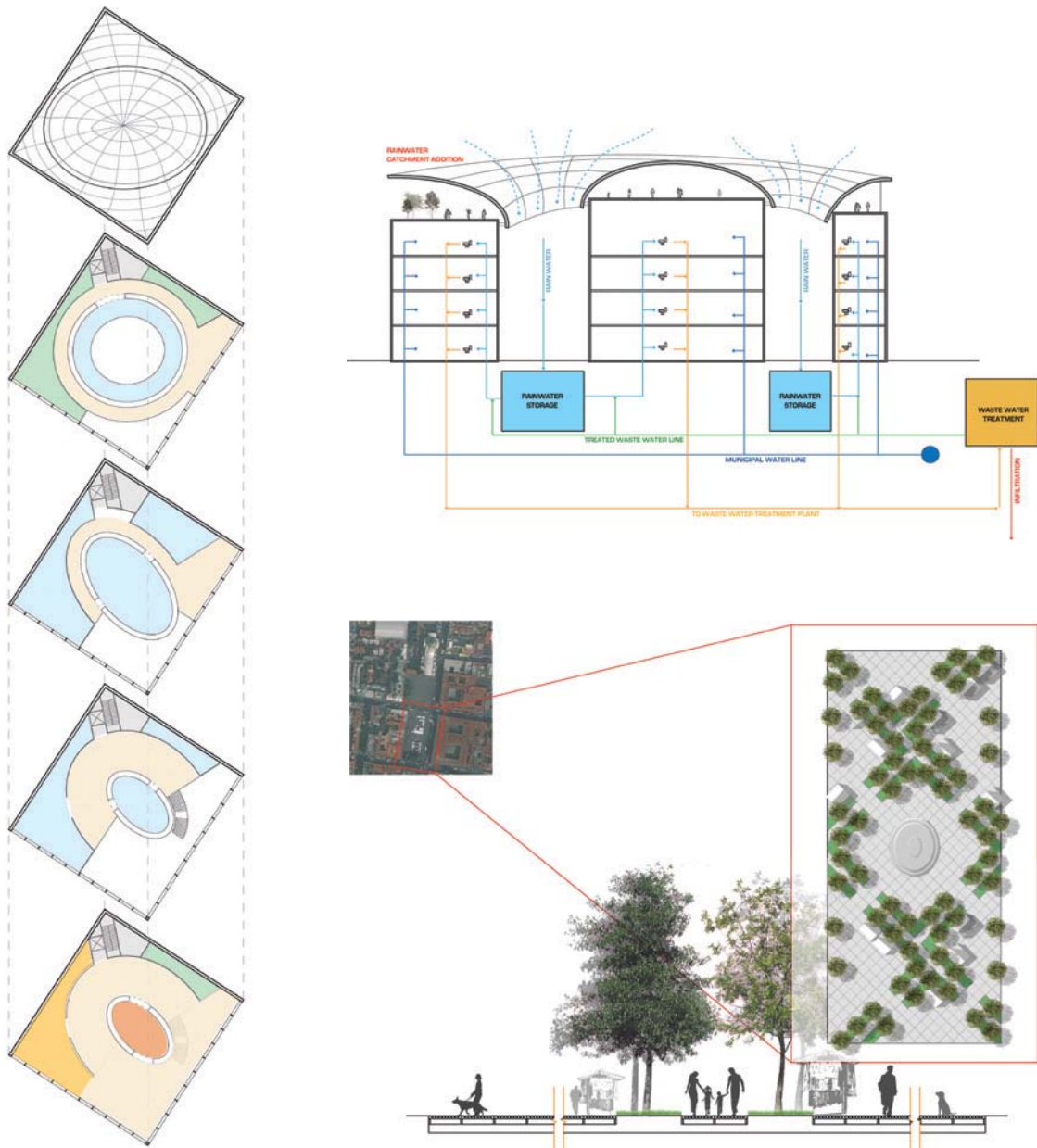

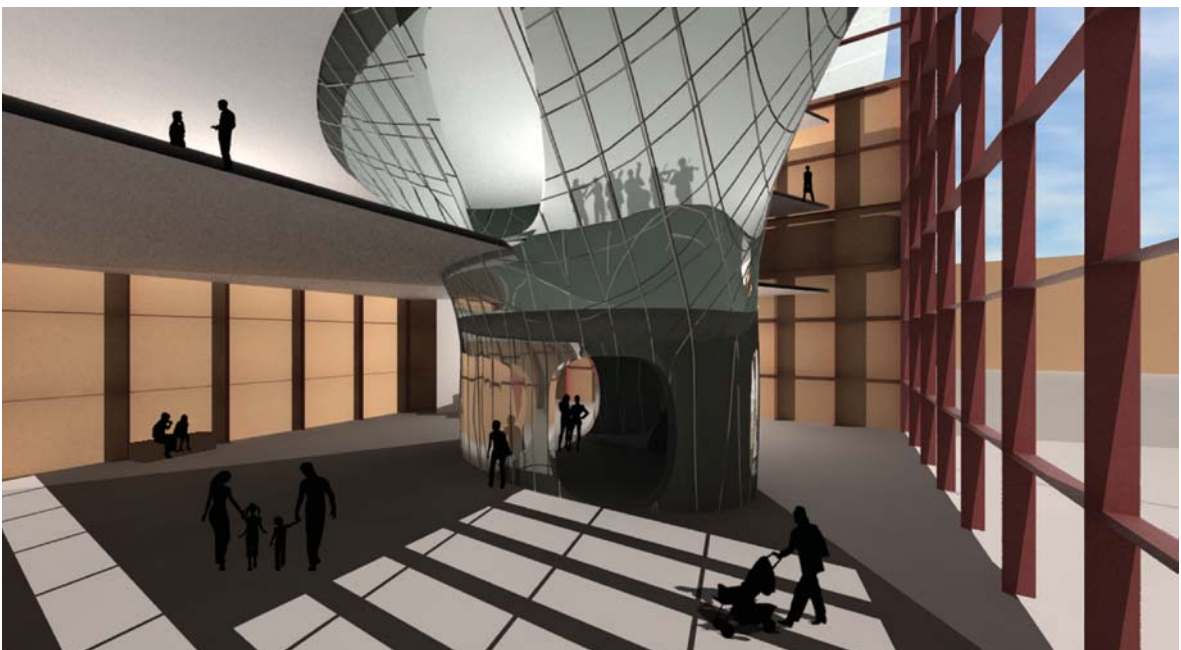
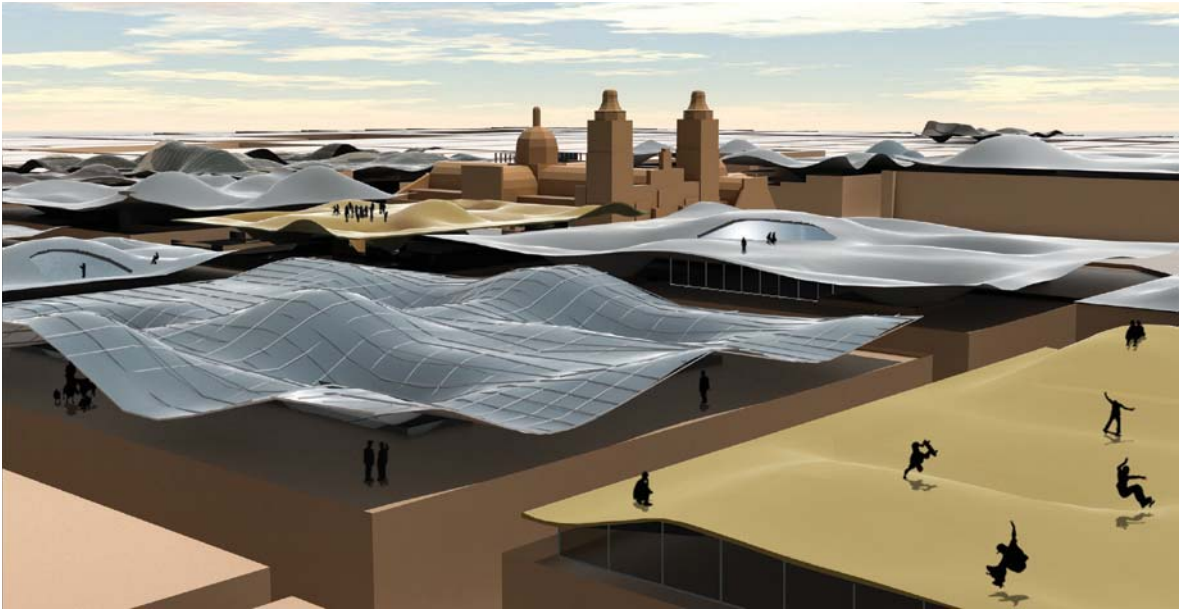

**PP@PD [POST-PROFESSIONAL PROGRAM AT PENNDESIGN / ARCH 703
WINKA DUBBELDAM, DIRECTOR, WITH PILAR ECHEZARRETA**

The re-writing and innovation of architectural design and its structures requires a revolutionary change in how architecture is conceived now. From the notion that a building is a composite of standardized elements such as columns, floors and walls, we have to see buildings as composed of mass-customized “generative components.” Prefabrication as pure repetition of standard elements is an outdated mode of operation; mass-customized units are evolving as a series of varying elements, defined by an analysis of specific performance, rather than merely structural requirements. Standard repetition has been replaced by custom variation. The components’ intelligence refers more to car- and plane-design than to architectural design, is more system-based than a mechanical assembly-based. Prefabrication itself is changing as well, where before it would be described as the industrial manufacturing of the same repetitive element, now units are custom-manufactured in a series of varying elements, specific for its use and in its efficiency. This more organic systematic way of thinking is new for architects, but common ground for scientists and industrial designers. The studio analyzed, mapped and developed different versions of ‘smart components’, which finally resulted in an assembly of building components for the new Architecture School for PennDesign. The study of smart components through data and site visits to car design companies in Los Angeles, allowed for an innovative approach. The students entered “Eye for Why,” a U.S.-based design competition organized by James Dyson, the award winning industrial designer. [www.dyson.com/designaward]

YIN LI: ET: Educational Tower—Knowledge should be accentuated in a school of design. The knowledge in the new Penn School of Architecture is divided into two parts: knowledge resources and knowledge digesting. Knowledge resources will be dispersed throughout the school. Communication then becomes the most important factor for knowledge digesting. Large interface focused activity spaces contain functional areas such as teaching spaces, studios, and workshops. The situating of these spaces aim to increase the communication and interaction with the whole school without establishing clear boundaries.

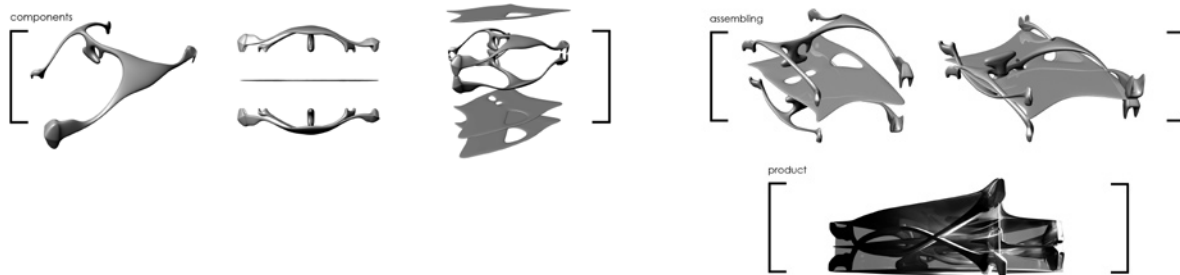



ERIC STROUD: Design for the UPenn new school of Architecture—P/ARC. The design was implemented using a single intelligent component that was repeated and varied to create the space. Each component integrates space for program, mechanical services, and circulation, as well as connections for floor systems and façade. Through this system, the building no longer relies on traditional Cartesian construction methods.

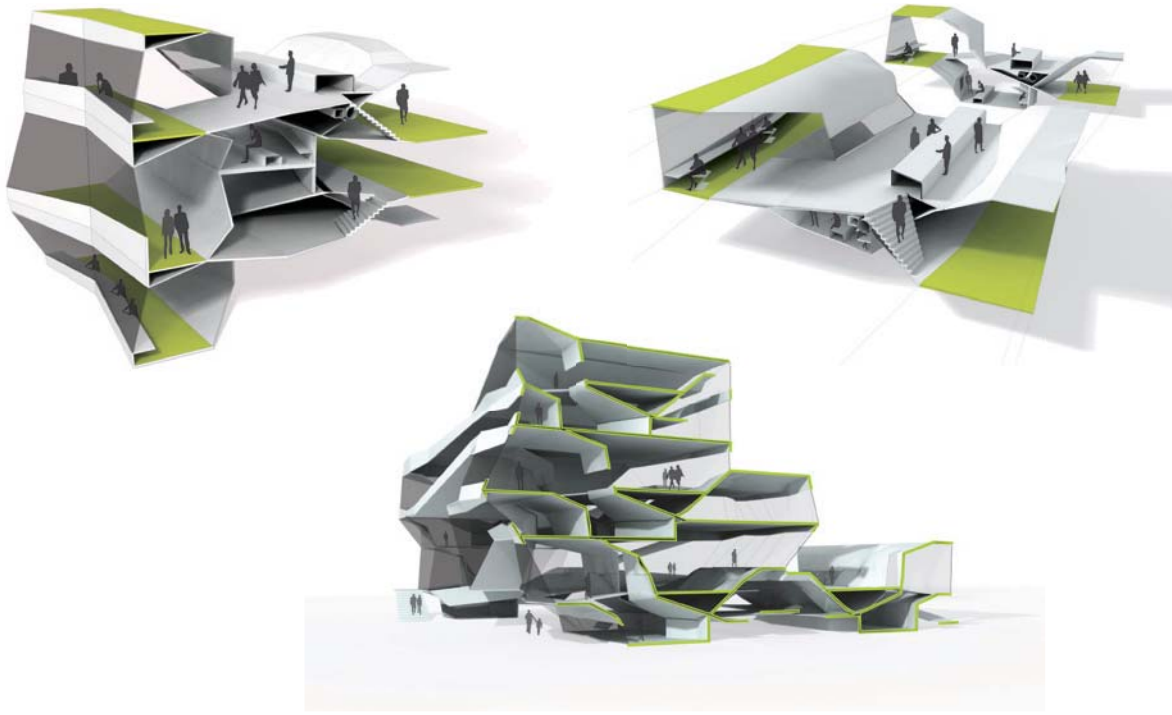

- HUAYOU LI:
- Consider faculty, staff, and students as fluid elements in space.
 - Each timesharing unit has a distinct character of its own which reflects the demands of its occupants.
 - Suggested method for time allotment can simply require logging in and out of the spaces.
 - Each space will have memory identifies the user and the space, thus giving character to the space and creating a certain environment.

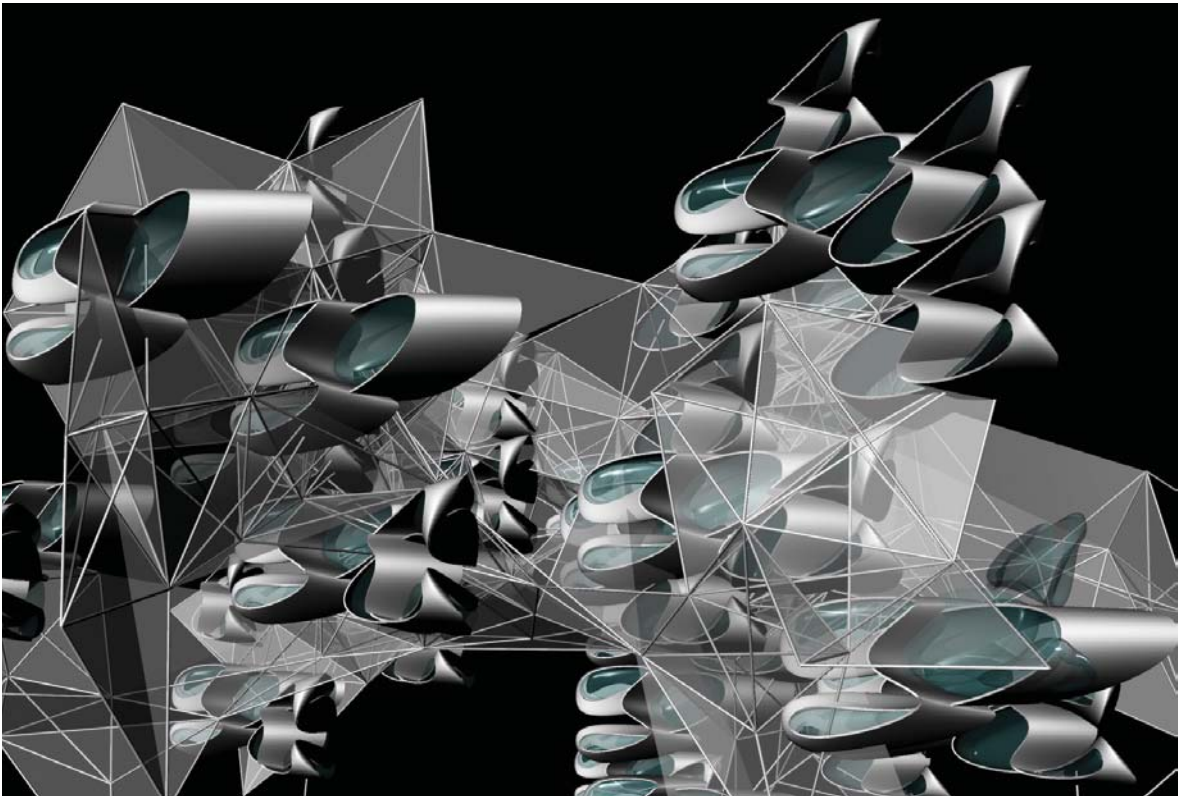
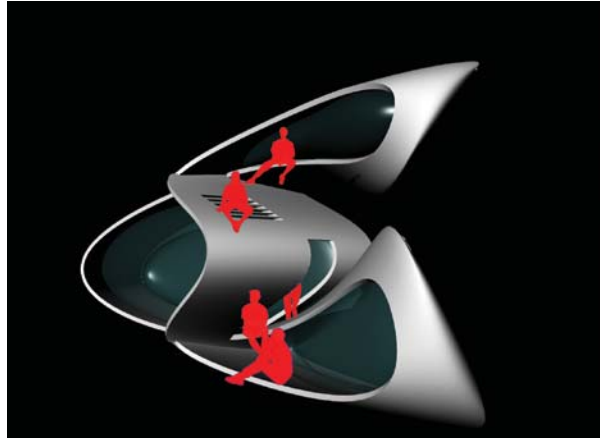
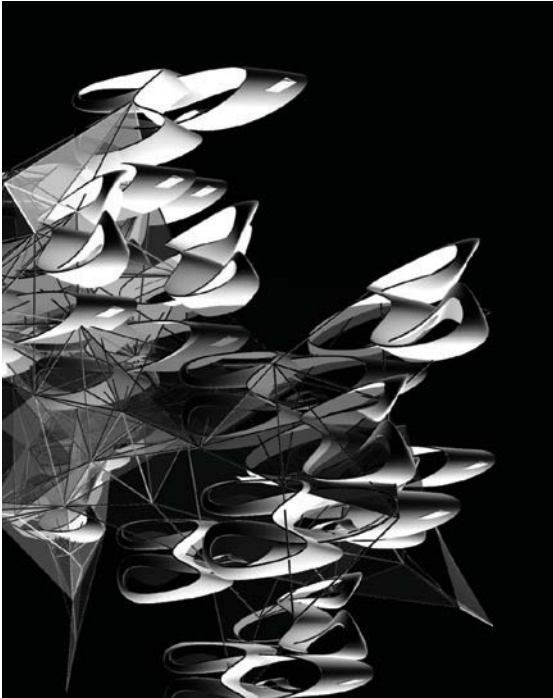

ARCH 704
DESIGN STUDIO VI / RESEARCH STUDIO / DETLEF MERTINS, COORDINATOR

For the past six years, the final semester at Penn has been comprised largely of Research Studios in which students engage the research agendas of instructors, developing trajectories that redefine the discipline of architecture. In Spring 2007, Research Studios were offered by Cecil Balmond, Winka Dubbeldam, Homa Farjadi, Stephen Kieran & James Timberlake, Rhett Russo and Marion Weiss. Topics ranged from algorithmic design to component design, hybridization, ecological-economic development, natural models of structure, and the integration of building and landscape ecologies. In the spirit of Benjamin Franklin, these studios bring theory and practice together, transferring knowledge from other domains to renew architecture's capacity to effect change in the world today.



complete set

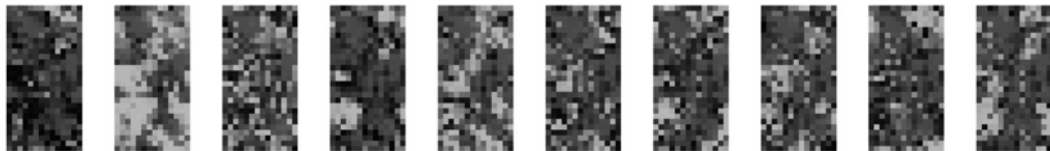

white cells



black cells

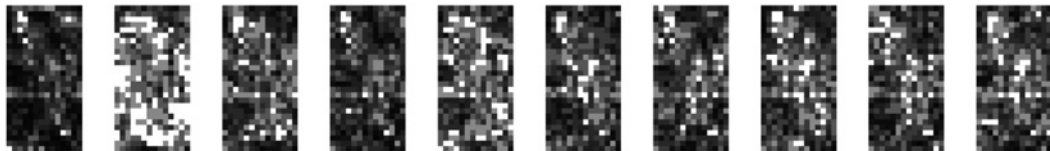

NANOTECH

Nanotechnology is an emerging science in which new materials and tiny structures are built atom-by-atom, or molecule-by-molecule, instead of the more conventional approach of sculpting parts from pre-existing materials. Nano is a prefix meaning one-billionth, so a nanometer is one-billionth of a meter. Nanotechnology is the science of the very small.

The new Nanotechnology Research Facility at Penn will support interdisciplinary research teams and industry partnerships with varied types of laboratory space. Included in the facility will be clean rooms, biology and chemistry laboratories, a library and an interdisciplinary Ideas lab. The building will also include epitaxial growth facilities that are used to make new materials and devices, such as silicon crystals used in the semiconductor industry. The term epitaxial comes from the Greek word meaning 'arranged upon.' In semiconductor technology, it refers to the single crystalline structure of the film.

The studio began with research on nanotechnology. This entailed the abstraction of intelligible variables and their relationships from mathematical, natural, biological, programmatic and geometric models. The studio employed a variety of digital and material-modeling techniques with the common goal of the abstraction and extension of complex systems to built form. A specific focus was placed upon programmatic relationships across the Nanotechnology facility. This led to the development of physical and digital algorithms; the algorithm was the procedural technique and scripting brought complexity to built form. Material had its own feedback and experiments in modeling and fabrication aided the investigations. Systems were nonlinear in their complexity and made intelligible at discrete moments through imposed hierarchies.

LIGHT + EDGE

LINDSEY COHEN, HYOEUN KIM, ANNA NESSER, ERIC STROUD: Research on gold nanoparticles introduced the catalytic relationship between light and edge. Programmatic distributions were established via ratios of lab, mechanical, and circulation spaces, and were explored through a 3-state cellular automaton (CA). The CA allowed for new adjacencies and programmatic relationships to emerge. Analysis of seasonal light conditions on the site provided a catalyst by which to articulate the light qualities, orientation and envelope of the building.



SKYSCRAPER AS BIOME

The sixties Skyscraper is taken here as a case study. The tower's traditionally repetitive components will learn, and be derived from an intelligent biological system; hence, the future skyscraper will be organized by a varying component system with "sequential variation", "transmutation" and density. *La Fonction Oblique* by Claude Parent & Paul Virilio [1967] already reconsidered the importance of human orientation in relation to the inclined plane and the oblique axis, a development that the editors heralded as the platform for creating a "new urban order, if not the total reinvention of the architectural vocabulary.

In this studio, structure, traditionally a result of engineering was analyzed as a biome, structures which develop and behave not unlike organisms evolving in an ecosystem. The studio investigated different biological systems, which typically develop from cell, organ, population, and species into communities. The skyscraper is a highly organized structure, its original form a direct consequence of the invention and introduction of the elevator. The studio's premise was that its future generation will innovate and evolve according to the performance and behavior as studied in biological systems. This analysis was aimed at generating a sequence of intelligent, generative components, which relate to each other and as part to whole. The studio analyzed, tested and mapped the different evolutions of variation and repetition following the scientific method: observation, hypothesis and experimentation of the skyscraper as biome.

THE SKYSCRAPER

ISIK ULKUN: The skyscraper is a mixed use building which provides many amenities to its inhabitants such as areas for outdoor leisure, relaxing units, kindergarten, exhibition areas, restaurants and office areas. The building combines different components which are designed as specialized cells inspired by the intelligence of the nervous system and the neuron cells. The components provide different degrees of privacy, various programs and size; enabling the skyscraper to perform as an interconnected system.

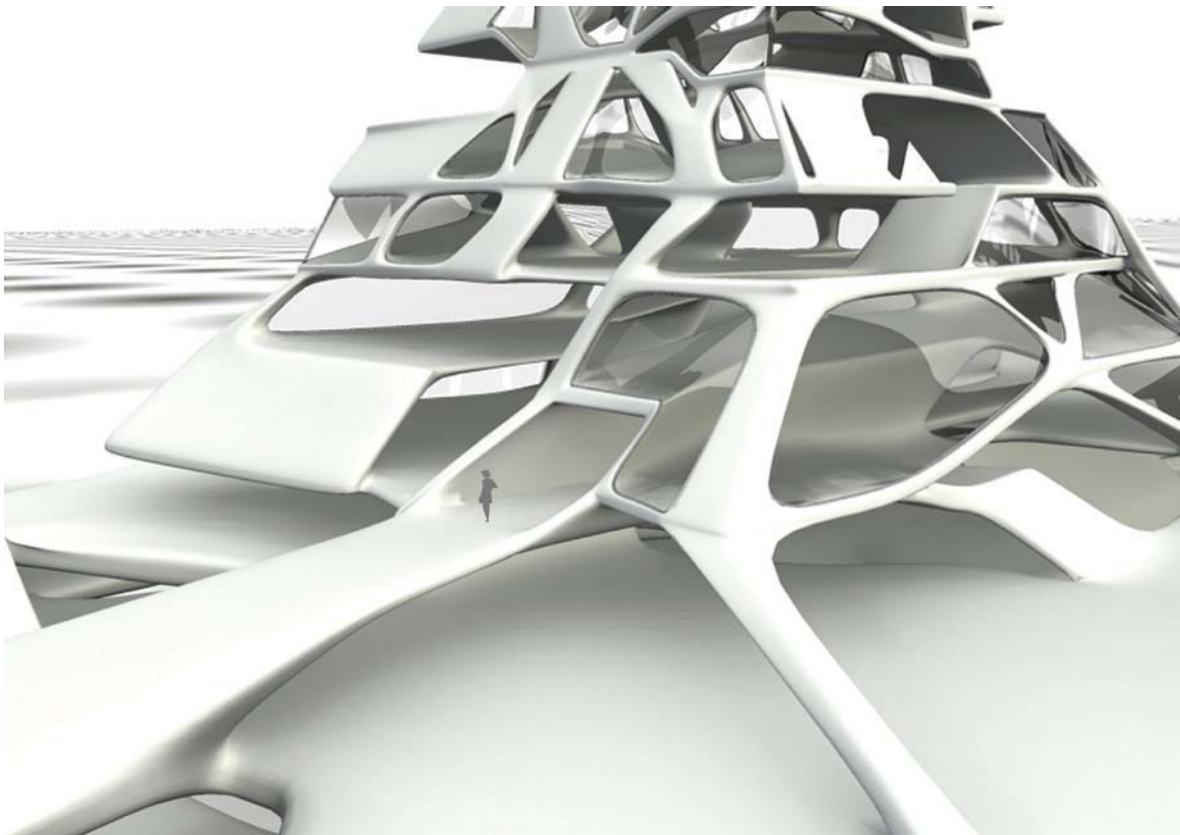

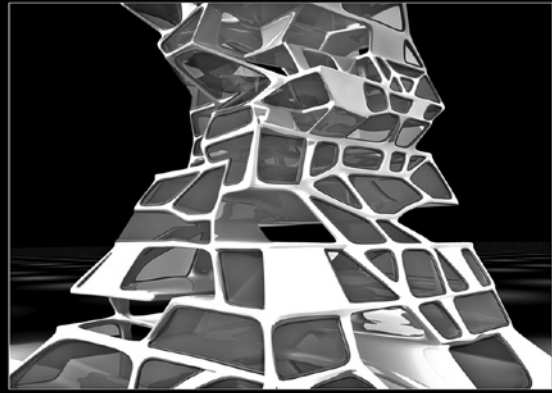
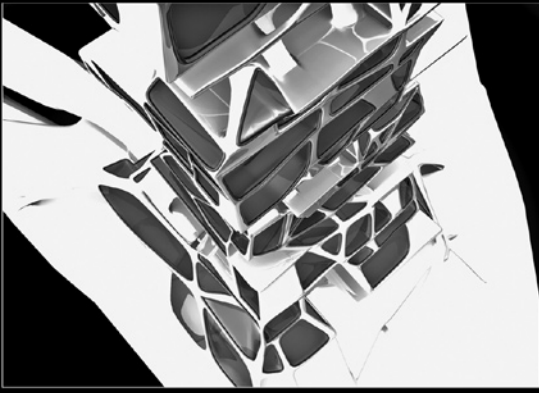
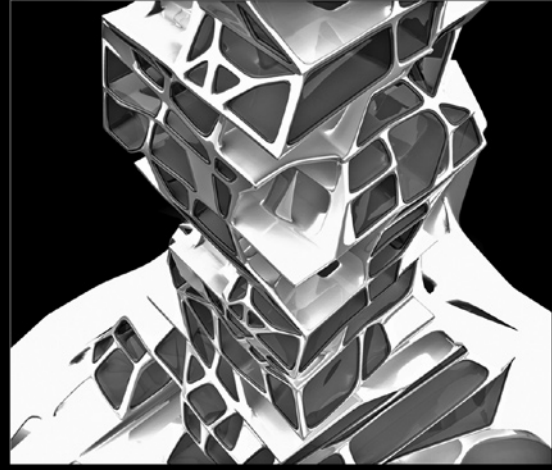
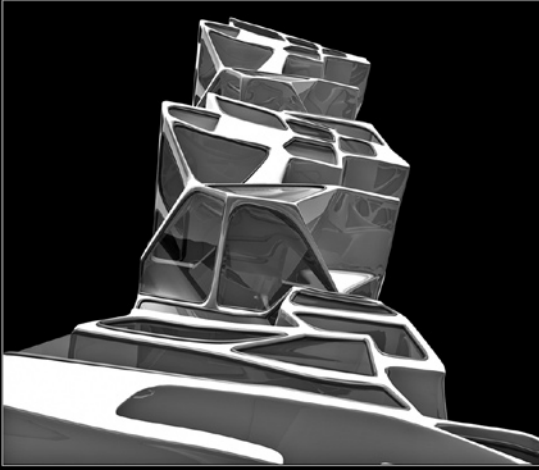

MULTIUSE TOWER - THE COMPONENT ORGANIZATION

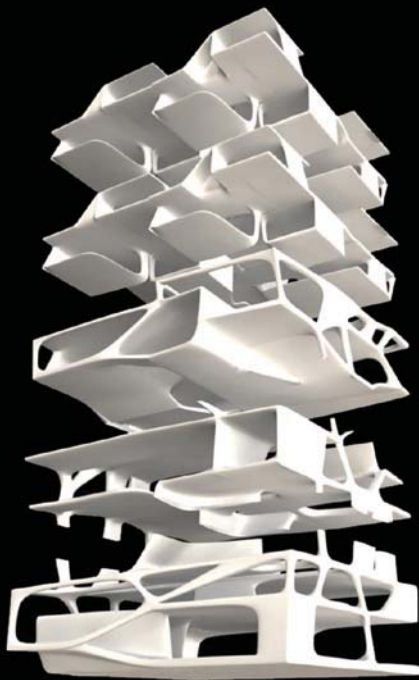

Multicell D



relaxing units
with patios

Multicell C



kindergarten,
restaurant

Multicell B

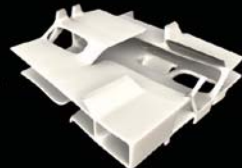

office, terrace

Multicell A



shopping, art
exhibition

VERNACULAR TRANSLATIONS—DOMESTIC PRETECHNIQUES

This studio was one of a series that has explored the potential of discursive crossings, bringing together thinking and processes from apparently distinct domains to generate the formation of the project. This year, students selected a vernacular building in a landscape, such as a farm house, an agricultural building, a hut or country house. Vernacular architecture is effectively produced as an evolving tradition through what might be called “pretechniques” that embed intelligence in material geometries and spatial formations without absolute predetermination. Vernaculars evolve slowly over time and through many repetitions in which spatial organization, dimensional ordering, structure and materials vary in response to local geographies, social habits and material ecologies. The studio reworked the pretechniques of our examples in an accelerated kind of evolution by engaging with contemporary technologies of design and construction.

The work of two contemporary figures, one an artist (Eduardo Chillida), the other an architectural historian and theorist (Robin Evans), was used to inform this process. Both were trained as architects but side-stepped its central practice to refine it through contiguous fields. Close readings of seminal essays by Evans and analysis of Chillida’s abstract sculpture provided a discursive lens with which to restore this contiguity to a central role in design.

LIYANG DING: Based on the studies of Gnomon (Chillida’s work) and log-house in the US, the project approached residential housing with irregular layers of impermeable elements, which are compact and stable; they are also broken by secret labyrinthine passageways, and the application of new development of traditional construction technique of log-house at the corners.

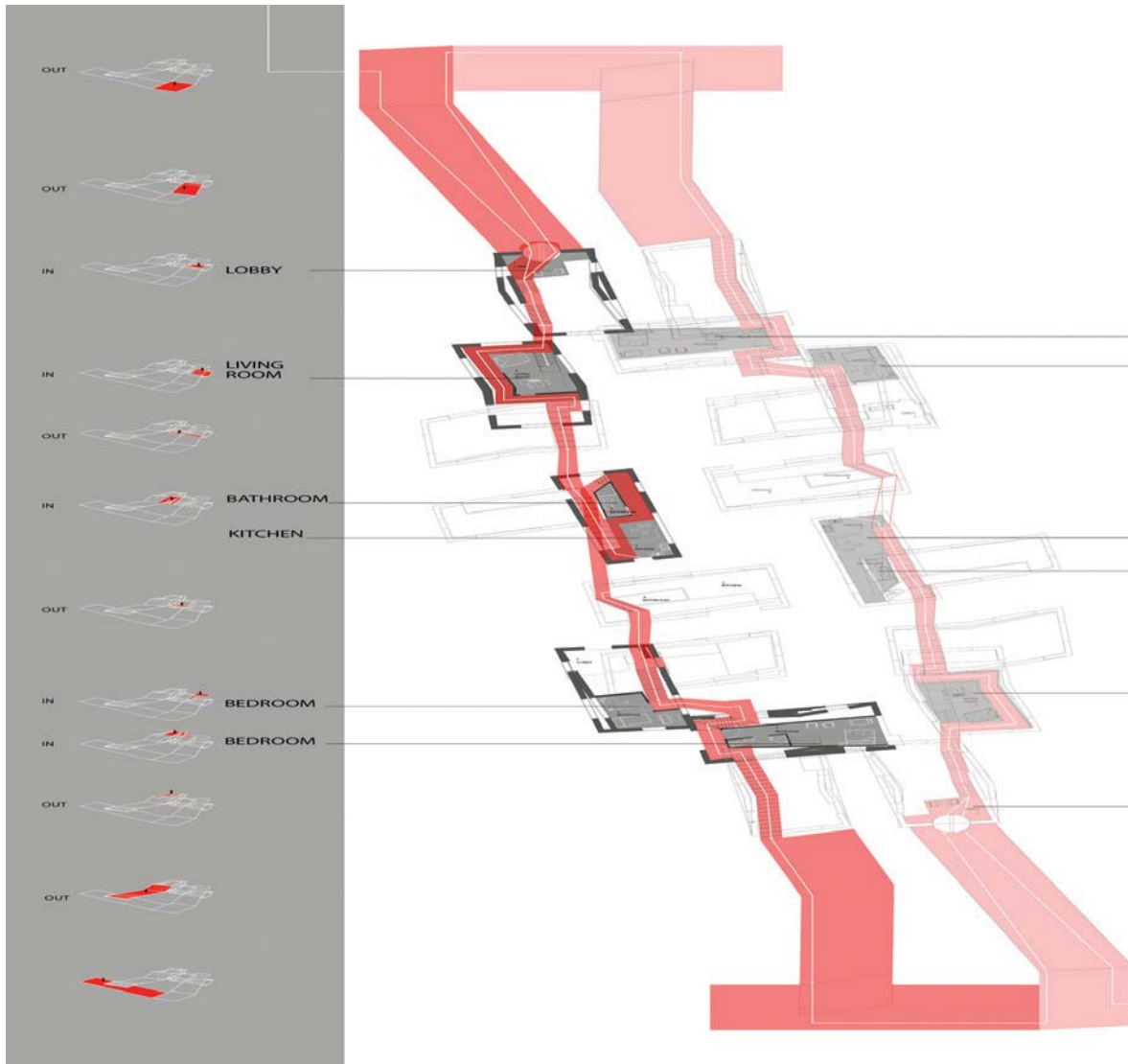

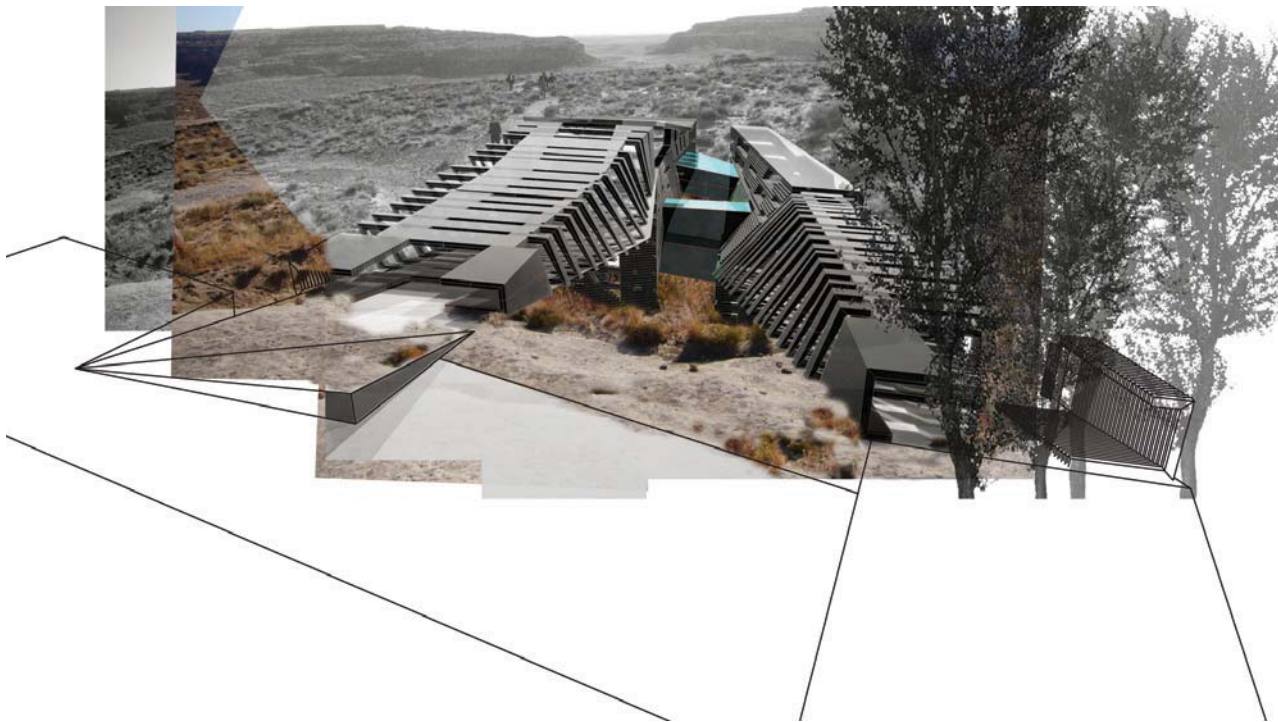
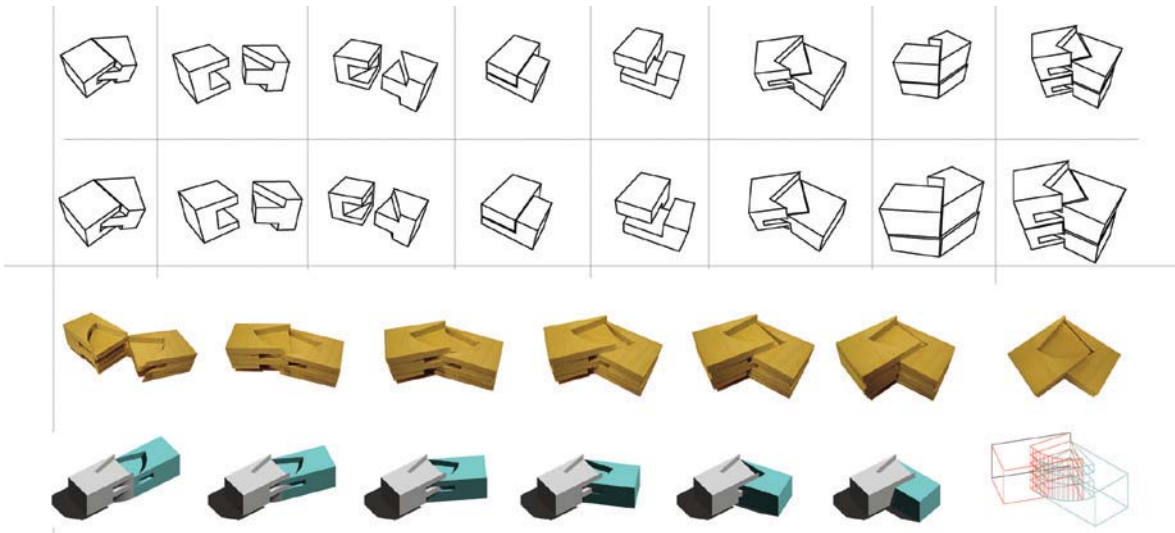

The studio is the first year of a five-year open source collaborative laboratory where teams of students were asked to define a problem through questions and speculations based on topics provided. Subjects included Embodied Energy, Life Cycle, Infrastructure, Fabrication, Social and Economic Impact. These topics became the genesis of a semester-long research agenda that culminated with an applied design research problem.

Working in teams, students defined a problem in the developing world that emerged from their combined research. Groups then designed a product, a process or a strategy that is intended to become a catalytic event to extend growth into sustainable patterns.

JULIA COX, ROBERT LIBUTTI, RYAN LOHBAUER: Residents of developing nations, with limited capital, often struggle to obtain many of their basic needs. Our team chose Dhaka, Bangladesh as a case study of a rapidly expanding "Mega City" that suffers from a variety of urban problems. The DhakaBlock uses well-established materials and manufacturing techniques to produce a product that addresses two fundamental problems, drinking water procurement and shelter. The DhakaBlock can be combined with multiples of its own kind or with local materials to construct a variety of structures and functions. One DhakaBlock can store enough drinking water to supply one adult or two children for a year.

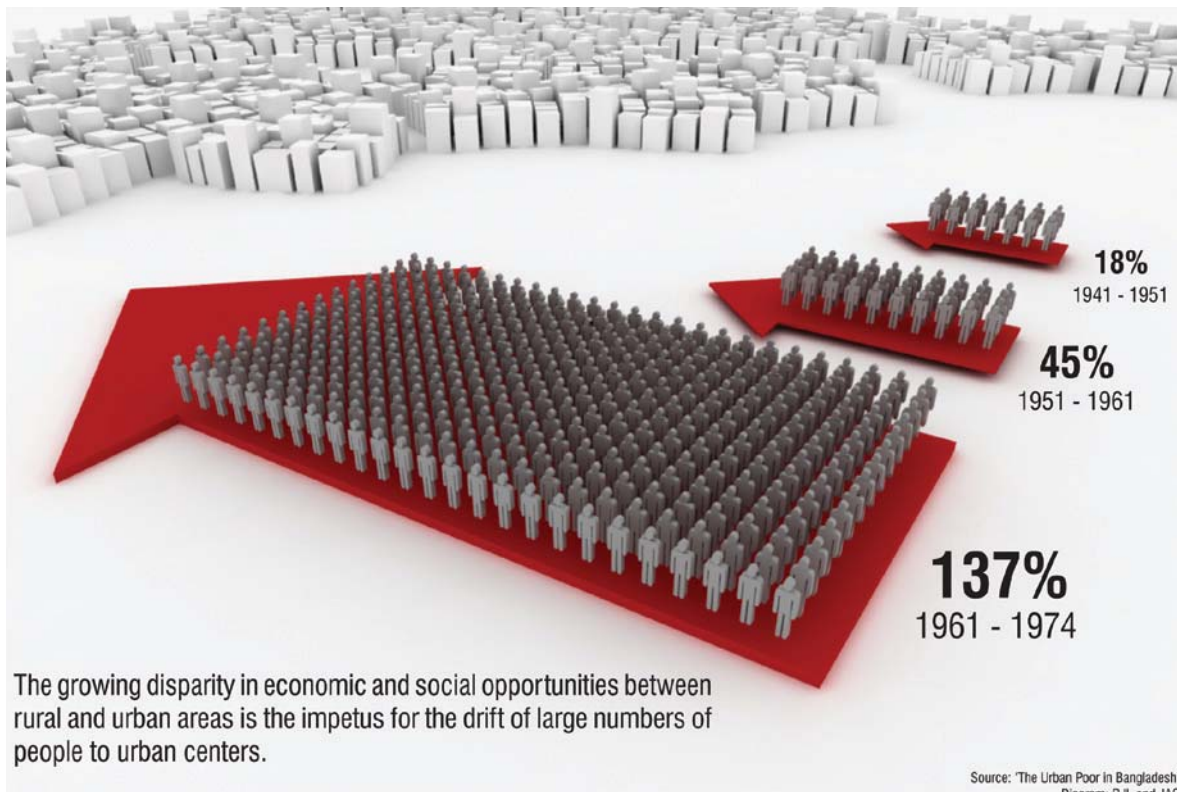

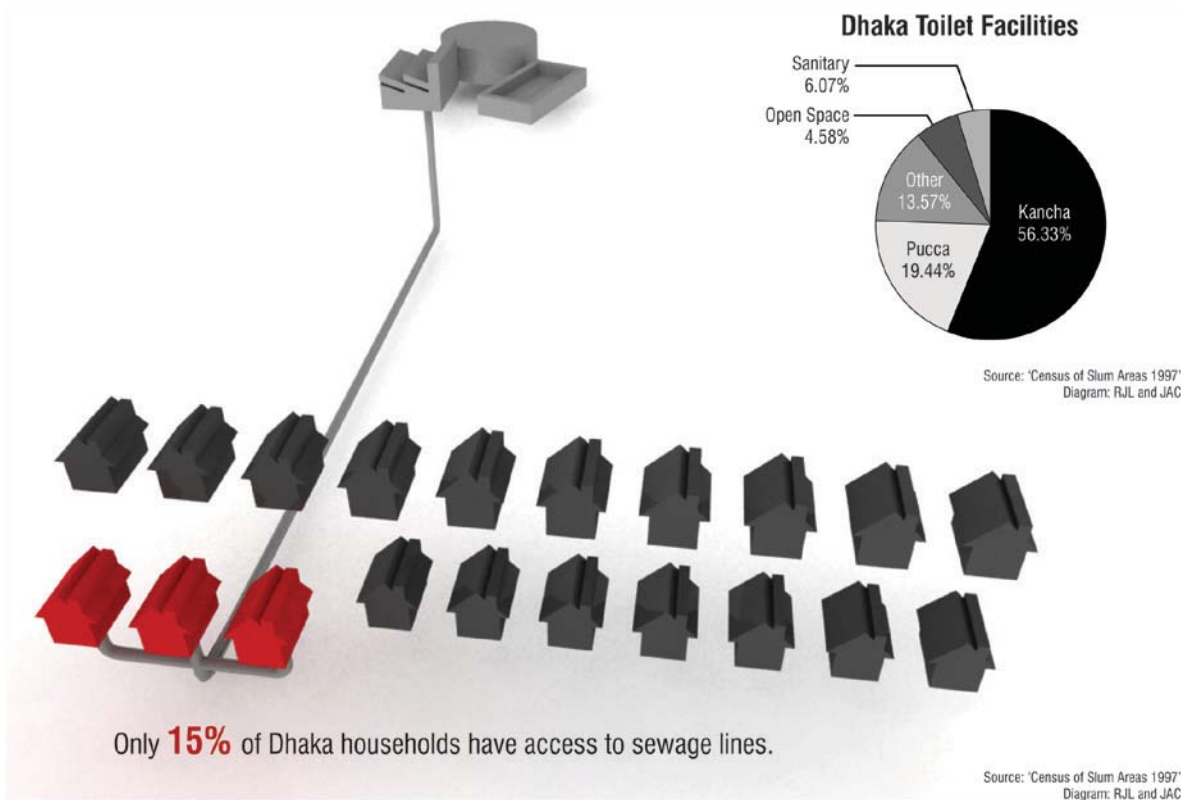
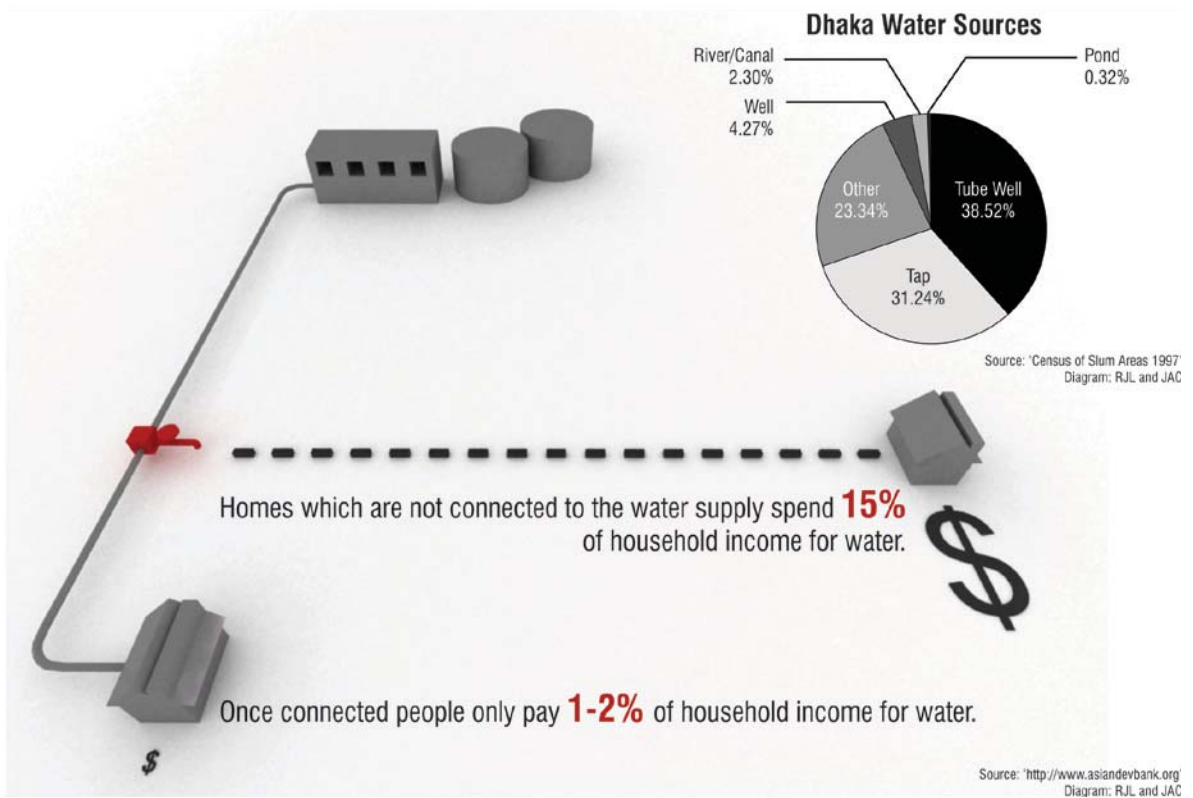

SYNSEDIMENTARY STRUCTURES

TWIST: Gardiner Oregon is the existing home of the International Paper Company's former paper factory. This factory has been abandoned, but has left behind a large electrical pipeline infrastructure that served as a power inlet to operate the plant. Ocean Power Technologies is interested in locating their headquarters, The Wave Energy Conversion Research, Development and Demonstration Center, on the post-industrial paper mill site and hopes to use the old infrastructure to distribute power back into the grid. Proposals will develop both the wave harvesting field and the research center. The center will provide engineered environments to conduct buoy simulations and to monitor their performance during storms.

DEVICES: Synsedimentary structures are defined as rigid forms that develop through slow accreted growth that can be either enzymatic or non-enzymatic. In corals, these structures develop through a symbiosis with the zooplankton that inhabit the reef and thus sustain the corals growth over many generations. The studio investigated several types of sysedimentary features found in ocean corals and explored their potential as architectonic shell structures. Advancements in nozzle technology are now allowing scientists to spray material at unprecedented scales, and to aggregate structures ranging from cell substrates to concrete structures. The studio experimented with using a 3d scanner and mesh data to analyze the synsedimentary growth of a variety of species of coral in greater detail.

OCEAN POWER RESEARCH AND DEVELOPMENT CENTER

CHAUNCEY HERMAN: Coral grows in rare class III ecosystems, where energy exchange efficiency between organisms reaches near perfection. Symbiosis between coral and certain species of algae is so efficient that some colonies do not actually need to eat to sustain life. In this environment, coral structure and form can be dictated entirely by its efforts to maximize energy exchange feasibility.

Certain active and reactive forces within this natural model are studied and extrapolated to inform an overall architectural logic for the Ocean Power Research and Development Center. The facility's overarching purpose is to research alternative forms of energy harvesting, a line of study that increases mans efficiency and sustainability on earth. The facility is an epicenter for literal energy flow as it channels electricity generated from ocean waves and plugs it into the national grid, but it is also a center for the flow of knowledge. From observation, research, study, testing, lectures, and exhibits, knowledge of new technologies flows through the building and out into the general population. Form, structure, and organization become both reactants and informants to this programmatic flow and efficiency.

A series of plaster flow models, coupled with extrapolation of branching logic and growth rates from the Faviidae Australogyra coral species (two physical features of the species that maximize its ability to house the algae that it needs to survive), result in a system of ridges, compartments, and porous faces that is both structural and spatial. Through this system, information and energy is internally filtered from research, to education, and eventually, passed on to the greater community.

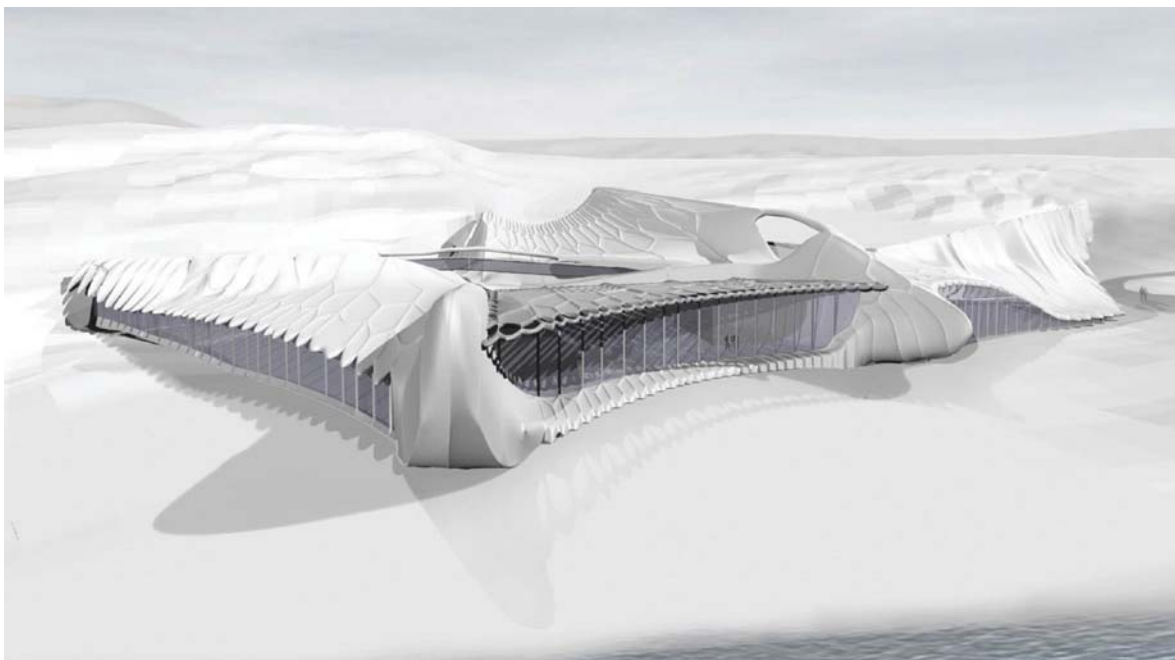

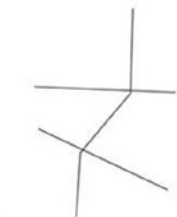
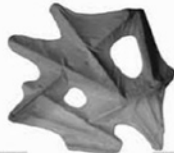
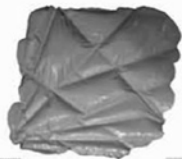
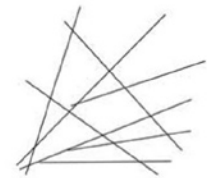
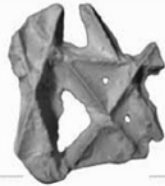
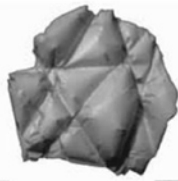
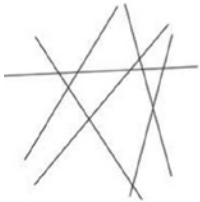
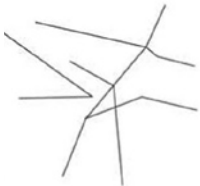
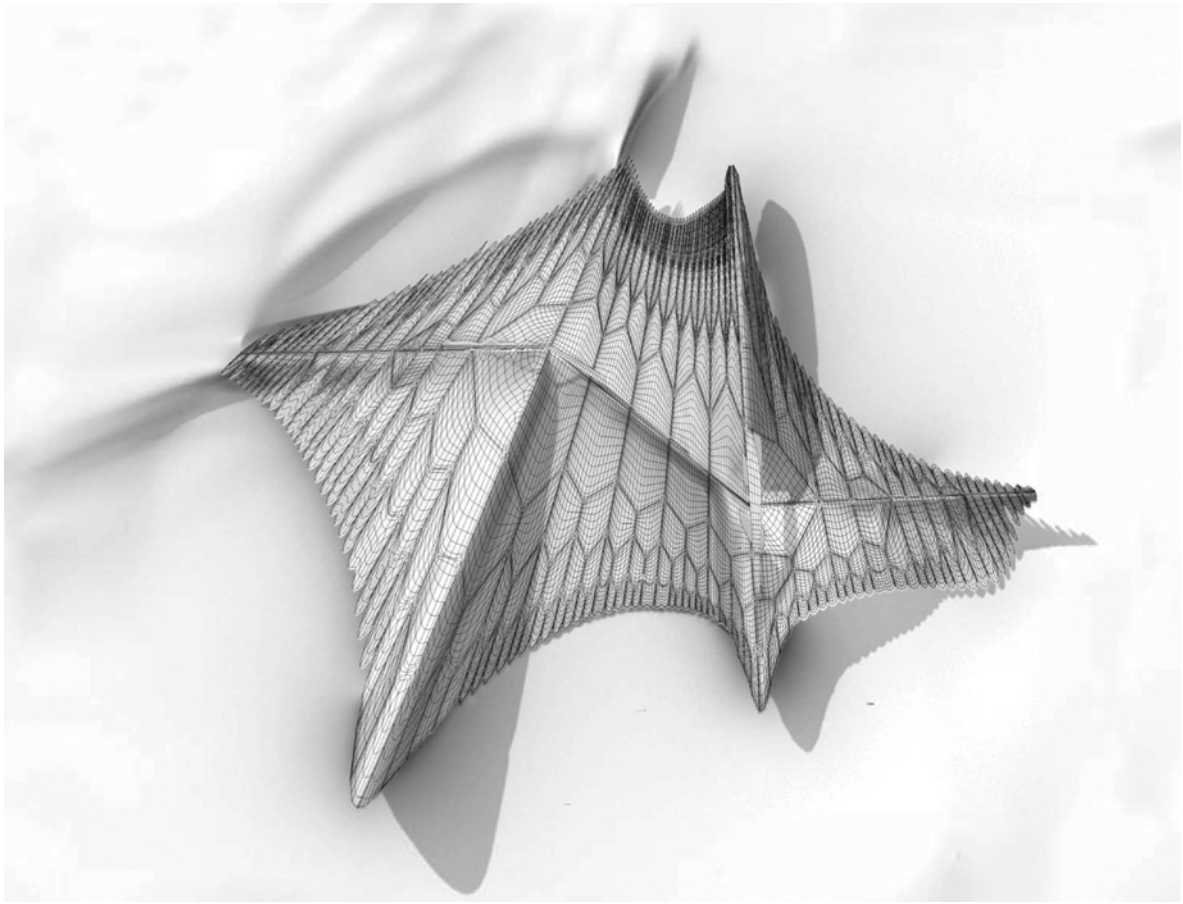

ISLAND ECOLOGIES

Governors Island, 800 yards from the intensity of Manhattan, exists as an elusive setting, accessible to the public by ferry and most typically by appointment only. Through an invited international competition, Governors Island is now in the process of searching for a new public identity for the island, capturing the paradox of its 'islandness' and proximity to intense urbanity.

This studio focused on the development of a new perimeter morphology that challenges the monolithically armored seawall and engages the highly diverse ecological, aquatic and historical infrastructure that surround the island. The studio proposed an alternative to the conventional opposition between liquid and solid, constructed and natural, infrastructure and inhabitation, envisioning a new topography that reconstitutes the surface and perimeter into more reciprocal collaborator with the water.

BRAD LEIBEN / JANG HEE YOO: The project explored lily pads with an interest in their capacity to inform the design of a resilient terrain on Governors Island, which will be increasingly subject to storm surges and flooding in the next century. In zones of high density, lily pads create rich overlapping spatial conditions and have a structural capacity as a rigid surface. In zones of low overlap the pads are relaxed and affected by water flows.

The project created a gradient between two extremes on Governors Island. On the vulnerable western edge the landscape acts as fortification and extends into the harbor, sculpting the bathymetric topography to reduce wave impact. On the calm, eastern shore the landscape becomes a place for cultivation and dissolves into greenhouse, garden, then floating gardens within the protected channel. Between these two extremes, two very different programs for the island collide. On the upper level of the architecture is a glass roofed public landscape and convention space. On the lower levels the space is intended for a horticultural research center. The architecture is designed to foster interactivity and connection between these two different users.

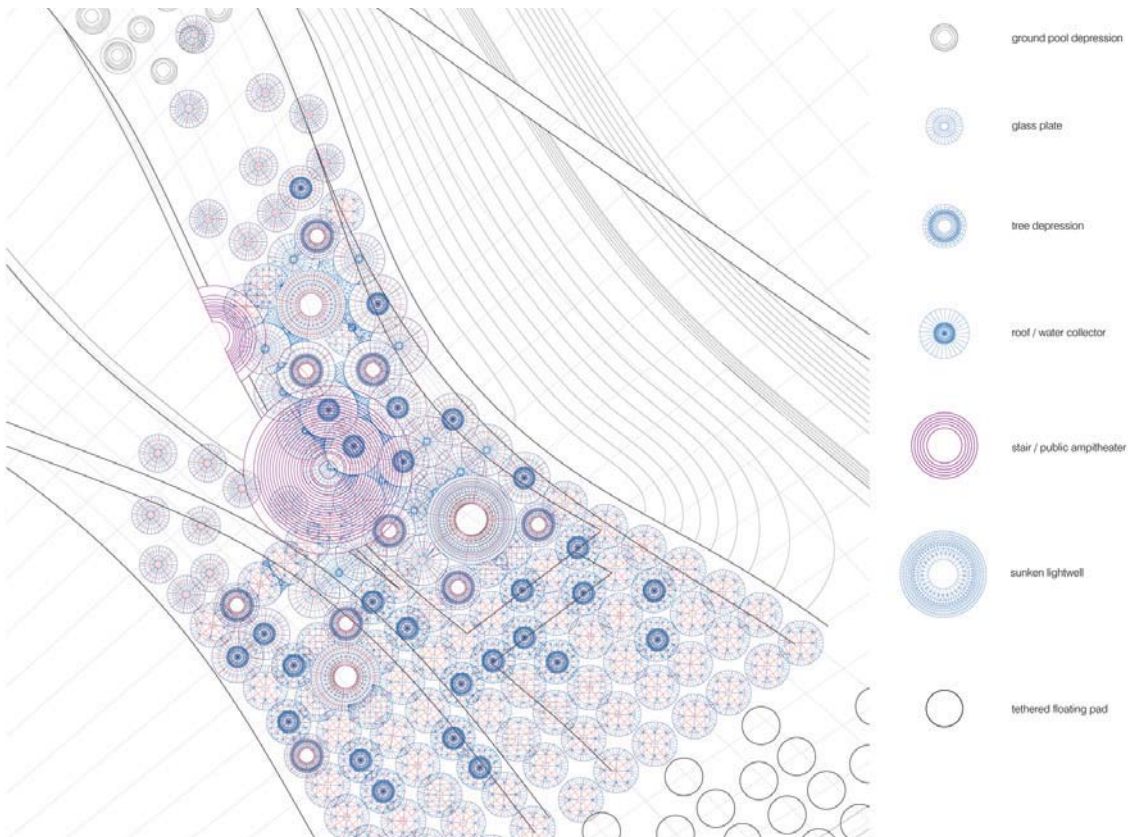
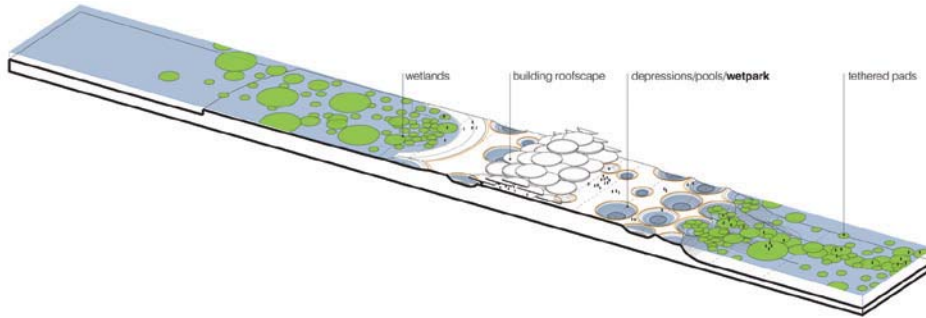

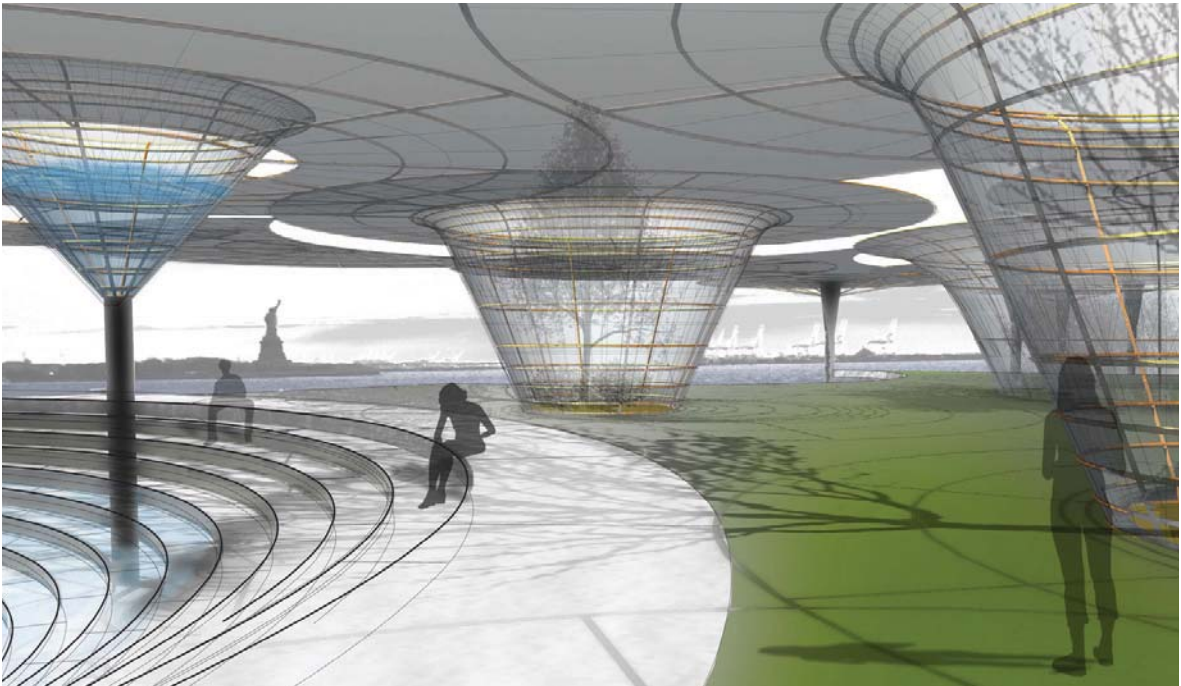
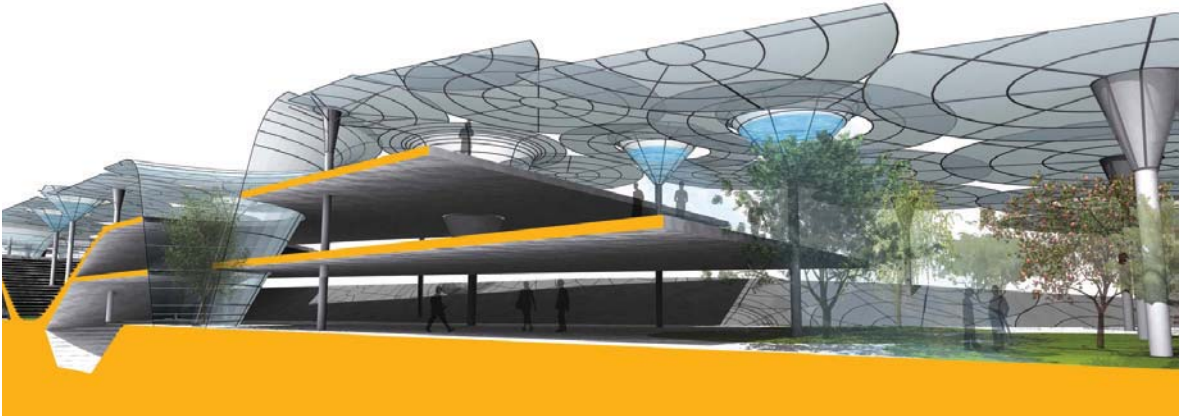

**ARCH 706
DESIGN STUDIO VI / INDEPENDENT THESIS / ANNETTE FIERRO, COORDINATOR**

In their final semester, students may elect to do an Independent Thesis rather than an ARCH 704 Research Studio, subject to approval by the Thesis Committee.

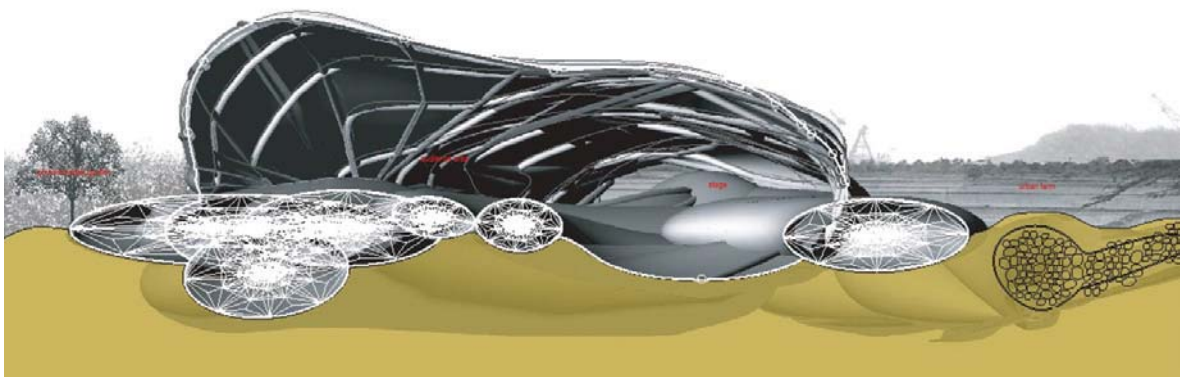

MUD ISLAND BIOZONE

KATIE BONIER: At the edge of our cities we have created toxic zones—frontiers marked by landfills, sewer outflows, industrial sites, and noxious clouds. Can we make the wasteland into a wonderland—a sublime landscape? I am proposing a germinal infrastructure to inhabit the liminal toxic reaches of Philadelphia, feeding on wastes, generating enclosure, heat, and luminous signals

- a spectacle, pneumatic and trussed spaces of land-building and water purification

The membrane filtration processor and the ecology it supports enables the overlap of programs and substances that would normally be kept separate. Nano and bio-engineered membranes selectively filter for certain molecules, controlling the remediation process, and allowing for specific concentration and orchestration of light, smell, and sound. Waste is converted into urban farmland, a buffer and a stabilizer for blighted neighborhoods. Event and education spaces are illuminated by fluorescing signal proteins and neon bioluminescent bacteria.

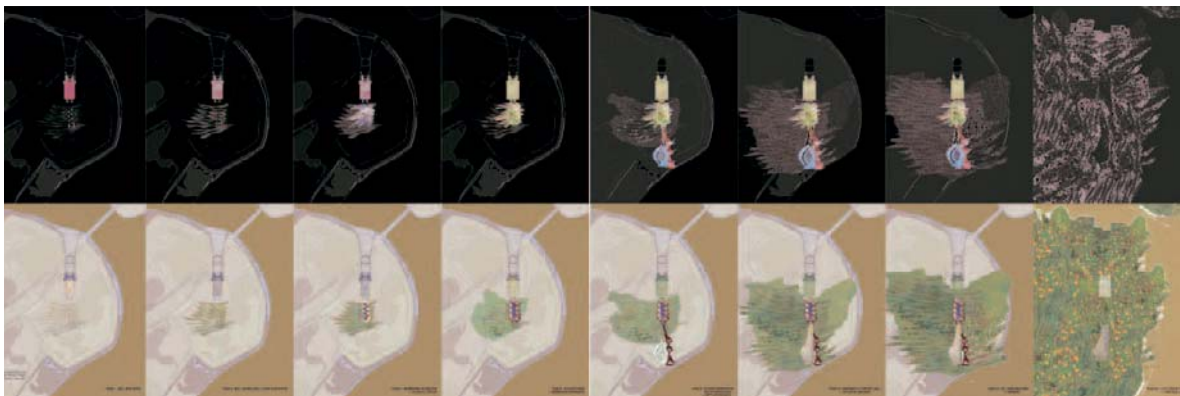
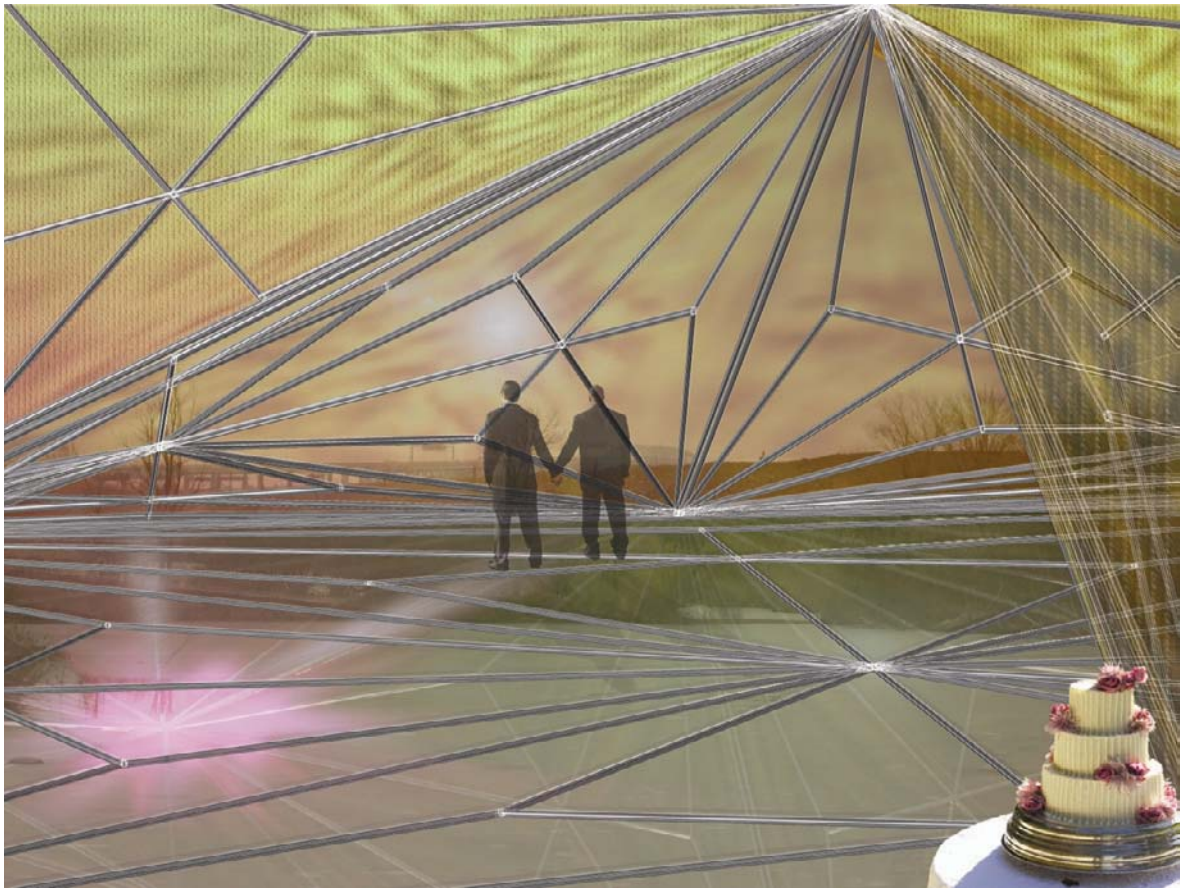

DISSERTATIONS

City as Process: Tange Kenzo and the Japanese Urban Utopias, 1959–1970
Zhongjie Lin; Supervisors, Jonathan Barnett, Annette Fierro, Gary Hack,

The dissolution of the *Congrès Internationaux d'Architecture Moderne* in 1959 was a critical and symbolic moment of transition that opened up possibilities for exploring new approaches to urbanism. The pursuit of new urbanism in Japan in the postwar period often took the form of utopian speculations that reflected currents of socio-ideological changes and diverse local conditions. This dissertation examines the issue of utopianism in contemporary urbanism through an investigation of the Japanese Metabolist movement, and in particular, Tange Kenzo's works of urban design in the 1960s. It aims to situate this avant-garde movement in the context of Japan's postwar urban reconstruction, rapid economic growth and socio-political transformation, and argues that the Metabolists' futuristic concepts, which often envisioned the sea and the sky as human habitats of the future, were in fact the architects' response to the particular urban and cultural crises that confronted Japanese society in the postwar era.

The dissertation traces the evolution of the Metabolist movement from its inception at the World Design Conference in 1960 to its spectacular swansong at the Osaka World Exposition in 1970. Based on a metaphor of the city as an organic process, the Metabolists rejected the Modernist planning methods to embrace a structuralist approach featuring a series of radical concepts such as marine civilization, artificial terrain, and metabolic cycle. Two ramifications of urban forms, however, arose from Metabolism's emphasis on the change and transformation of cities: the megastructure and the group form. They represented drastically different responses to the problems of modern city. Through discussions of Maki Fumihiko's concept of group form, Isozaki Arata's notion of ruin, Kikutake Kiyonori and Kurokawa Noriaki's ideas of technology, Otake Masato's employment of artificial ground, and Kawazoe Noboru's theory on tradition, this study attempts to provide a more comprehensive view on Metabolism that was characterized by diverse, complex, and even contradictory points of view, rather than a monotonous megastructural movement as usually portrayed in historical accounts. Its development involved debates of utopia and anti-utopia.

The utopian nature of Metabolism was manifested in Tange's seminal works during the 1960s: the Plan for Tokyo Yamanashi Communications Center, the Redevelopment Plan for Skopje, and the Osaka Expo. The 1960 Plan for Tokyo represented a sophisticated synthesis of the metabolist concepts on an unprecedented scale. Serving as a polemical alternative to the official plans of Tokyo, this project posed itself to fundamentally transform its urban structure for the imminent arrival of a post-industrial age, and heralded the architect's later works. The megastructural solutions in these projects betrayed technocratic notion of Tange, who attempted to control the process of urban and social development with predetermined patterns and technological means. This was coupled with his symbolic representation of urban and political ideals, which nevertheless remained unattainable in fact.



An encompassing Madinah: Toward a definition of the Moroccan city
Hassan Radoine; Supervisors, Renata Holod, Joseph Lowry, Frank Matero

While the general notion of madinah is largely familiar to a broad audience, its central importance to the making of the modern city and its sustainability as a dynamic component of the process of urbanization is often overlooked and deserves the closest attention. A careful scrutiny of the literature on the madinah will reveal the narrowness of most approaches to its study, so often limited, as it is, to the point of view of a specific discipline or period of time. In the case of Morocco, these are limitations which have led to a limited notion of madinah as an urban model confined within walls.

The present study challenges these concepts. It re-situates the Moroccan madinah not only in its historical context, but also within a functional theoretical framework. It provides also the necessary tools for understanding the critical transformations of the madinah in the 19th century with the advent of the "Modern" city.

I will argue the modernization of the Moroccan city not simply the consequence of direct colonialist intervention, but that it came about as a consequence of local elites endeavoring to transform the body of the madinah to better suit the European notion of progress to which they were increasingly exposed. Furthermore, I shall be analyzing the reasons behind colonial urban policies beyond the traditionally accepted categories of military or political justification. This analysis is made possible by existence of contemporary accounts of professional designers which have often been ignored by post-colonialist studies. Many of these designers were very active in disseminating their views which were often at odds with the colonial bureaucracy. Because of this, this dissertation will pay particular attention to the literature on 19th and early 20th century European urbanization, where concepts such as "urbanism", "historic city", "conservation", and "modern city", were later adopted by urban practitioners in the colonies, were first being developed.

This attempt at discerning the subtle threads that underlie the encounter of the "native" and the "colonial" in the field of architecture and city planning goes beyond the mere description of a historic period or the glorification of an urban model. It aims instead at the deconstruction of the Moroccan post-colonial city. It offers the basis of an understanding of the contemporary chaotic Moroccan city. It is hoped that this dissertation will be of help to professionals all those who are seeking to formulate practical strategies for the development of cities, both Moroccan and elsewhere.



COURSES / REQUIRED

ARCH 511 History and Theory I, Nadir Lahiji

This course investigated the ontology of the Formless in the maxims of modernity. Modernist theory in turn, in this view, is in a parallax gap with the discourse on Form. Modernity is thus grounded in a “point of view.” That is, modernity has a subject. But who is this subject? Methodologically, we distinguished two stages in this parallax gap in the history of modernity: ‘before and after’ photography, an inaugural and radical shift in the technology of images shaping modernity from the second half of the nineteenth century onwards. Based on this, we then studied the impact of architectural form on the parallax of modernity at large during the last three hundred years—with special emphasis on the twentieth century. Under the guiding concept of parallax, the twin notions of morphic and anamorphic were studied in relation to the theory and practice of building in various registers of space, geometry, structure, ground, optics, perspectival and “geometral” vision, among other topics. The same concept guided us to re-examine the discourse of modernity in its intersection with technology, aesthetic, and the notion of the subject in relation to social theory in discourses on ideology and the political.

ARCH 512 History and Theory II, David Leatherbarrow

The aim of this course was to introduce some of the basic topics of architectural order and the typical situations in which they occur. The course structure and its arguments rested on two premises: one, that these topics, this order, and these situations have been developed historically, and two, that architectural order cannot be understood without seeing the building in relation to a wider horizon of reference—the city. While these premises give orientation to both this course and architectural theory, they also bear on contemporary design, for it can be argued that the single most important challenge facing design today is to resume the battle for the city as the most effective and eloquent embodiment of contemporary culture.

ARCH 521 Visual Studies I, Igor Siddiqui (coordinator), Kristy Balliet, Alejandro Biguria, Benjamin Cadena, Justin Diles

This is a half-credit course that supports ARCH 501 Architectural Design Studio with focused instruction on drawing and its role in the design process. This course introduced modes, methods and techniques of architectural representation including visual analysis, descriptive geometry, media shifts, sketching, orthographic projection, axonometry and dynamic, sensorial imagery. The aim was to achieve a synthetic understanding of space in three dimensions and to promote design invention through work that visually manifests the active selection of representational media and techniques at a high level of competence.

ARCH 522 Visual Studies II, Cathrine Veikos (coordinator), Alejandro Biguria, Isabel Castilla, Justin Diles, Amy Johnson

This is a half-credit course that enables students to develop a three-dimensional spatial imagination and the architectural drawing skills that index spatial inquiry and allow for its two-dimensional representation. Through a series of exercises, the course introduced a methodology which interweaves salient skills from architectural drafting and rendering with digital 3d-modeling and rendering skills. The work involved a high degree of precision, logical rigor and innovation. Synthetic understanding of space in three dimensions and mastery of the skills required to both project and simulate these in two

dimensions was the goal of the series of workshops. The course placed emphasis on the speculative nature of drawings and their capacity to provoke the imagination and communicate ideas. As such, the workshops were complementary to design studio work; the drawings produced transcended the problem of representation to become architectures themselves. Our aim was to promote invention, thoughtful selection of techniques and their hybridization.

ARCH 531 Construction I, Lindsay Falck

This course introduced students to the basic principles and concepts of architectural materials and technologies of fabrication and assembly. It described the interrelated nature of structure, construction and environmental systems.

ARCH 532 Construction II, Lindsay Falck

This course continued the introduction of materials and methods of construction begun in ARCH 531, focusing on light and heavy steel frame construction, concrete construction, light and heavyweight cladding systems and systems building.

ARCH 533 Environmental Systems I, Ali Malkawi

This course studied human needs, comfort, performance, and sense of well being in relation to the physical environments both natural and man-made which occur in and around buildings. It introduced the mechanical systems in modern buildings with emphasis on tracing environmental, energy and waste problems. These problems make it imperative that architects be familiar with the systems that affect building energy use. Students gain understanding of those elements of buildings that contribute to their heating and cooling loads and methods that reduce the energy consumption. Different methods of analysis, evaluation, and simulation were introduced and employed.

ARCH 534 Environmental Systems II, William Braham

In this course we considered the environmental systems of larger, more complex buildings. Contemporary buildings are characterized by the use of such systems - ventilating, heating, cooling, dehumidifying, lighting, communications and controls - that not only have their own demands but dynamically interact with one another. The relationship to the classic architectural questions about building size and shape are even more complex. With the introduction of sophisticated feedback and control systems, architects are faced with conditions that are virtually animate and coextensive at many scales with the natural and manmade environments in which they are placed. The first task of the course was to understand those systems and their purposes in simple linear forms through analysis and calculation. The second task was to examine their dynamic interaction with one another - between lighting, cooling, and building shape for example - and with the environmental conditions they are meant to ameliorate. Coursework included the environmental analysis of a room in a building on the Penn campus. Such investigations involved measurements and performance simulations of environmental behavior and documentation of the HVAC systems of the building.

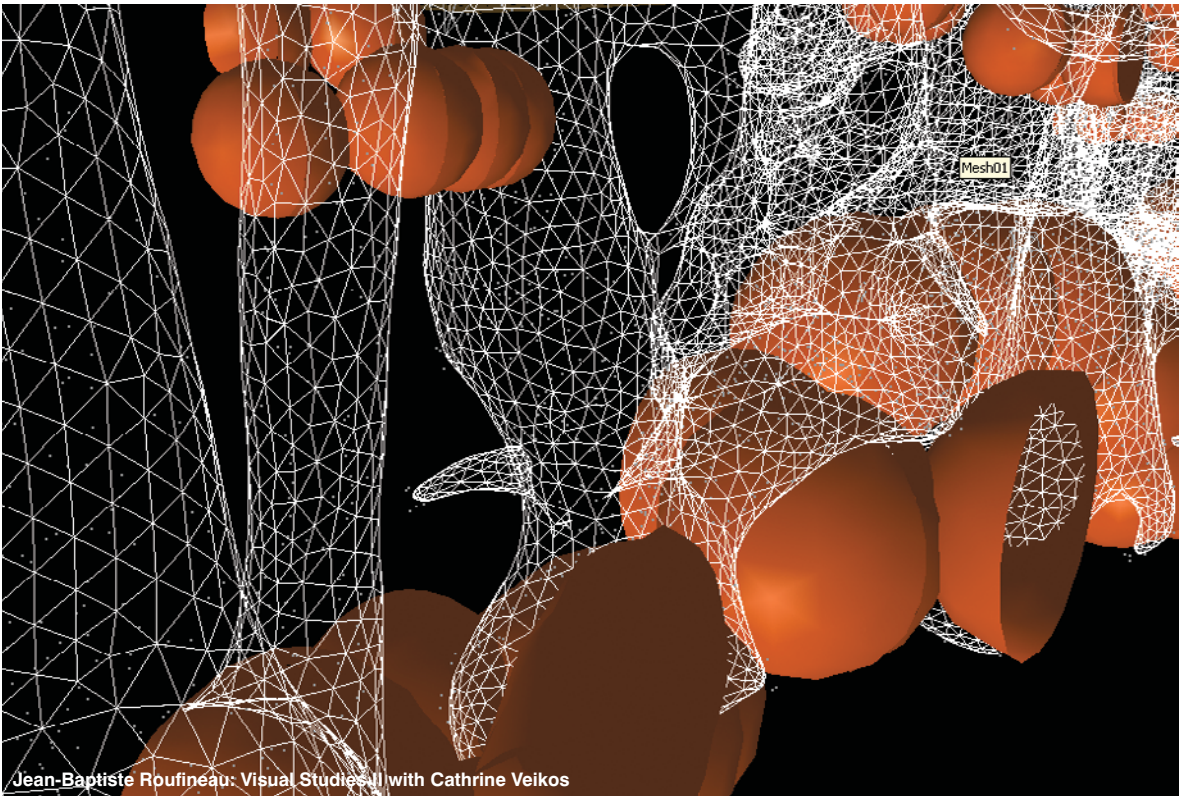
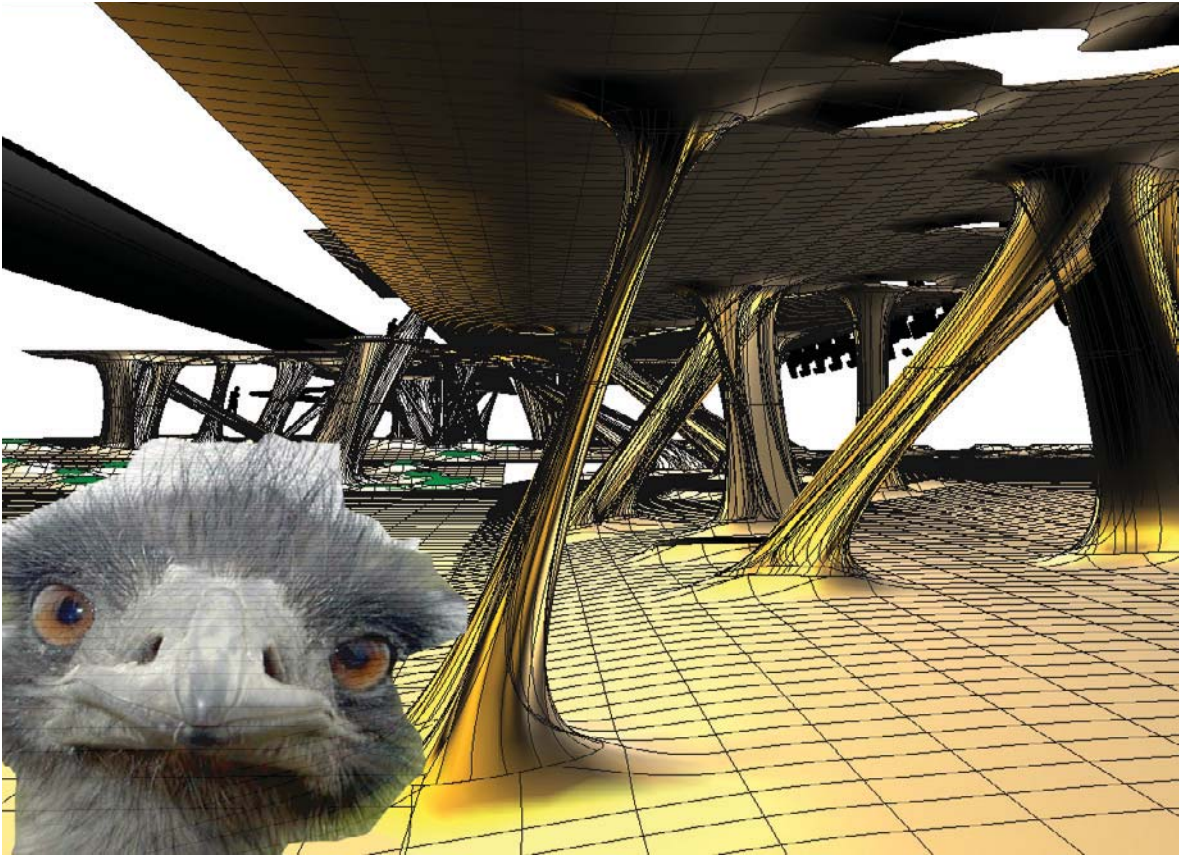

COURSES / REQUIRED

ARCH 535 Structures I, Richard Farley

This course provided a study of structural elements and their assembly into building structural systems, concentrating on design principles and structural behavior. The analysis and design of two-dimensional elements (flat and curved) and foundation systems were covered, as well as dynamics and composite elements. The course focused on observing and experiencing structural behavior, as well as the influence of the construction process on design of structures.

ARCH 536 Structures II, Richard Farley

This course is a continuation of the equilibrium analysis of structures covered in ARCH 535. Students studied static and hyper-static systems and design of their elements while learning to design for combined stresses and pre-stressing. The course focused on various structural elements, systems, materials and technical principals.

ARCH 611 History and Theory III: Architectures of Complexity, Helene Furjan

This course examined the prevalence of complexity theory in architecture today: the near ubiquity of systems models, dynamics, genetic processes and emergence, networked organizations, and digital fabrication. Central to this investigation is the vital influence of “diagrammatic” practices and theories and techniques of nonlinear dynamic organizations, coupled with advanced mathematics and emerging technologies. At the basis of architectures of complexity lies systems theory: a relational understanding of the world opposed to earlier mechanistic and atomistic models that break the world into isolated parts. Systems theory thinks in terms of dynamic, self-creating and complex assemblies. Complex systems are redefining the way we understand material behaviors and structures, allowing material to be rethought as “matter.” The genetic evolution of morphology—morphogenesis—is replacing more conventional notions of form and tectonics. Models of distributed, co-adaptive systems are shifting older notions of “sustainability” towards new formulations of ecology enmeshed with the theory of ecosystems. Field theories, coupled with models of network organizations, are changing the ways we view landscapes and cities, both manifestly and virtually. Space is redefined as an intelligent landscape of interaction and immersion; buildings as networked organizations, coupling infrastructural, structural, circulatory, programmatic, environmental, informational systems in tightly interconnected but distributed formations. “Design” is becoming “breeding,” “operation” is becoming “performance.” “Image” is giving way to “imaging”—branding, digital imaging, visualization techniques, format—and towards mood, atmosphere, immersion. Nevertheless, models of “systems” thought in architecture can be found as early as the Renaissance, if not before: the course tracked back from its basis in the present to locate the genealogical ancestry that prefigures much of today’s preoccupations.

ARCH 621 Visual Studies III, Cathrine Veikos (coordinator), Jason Dougherty, Bob Graustein, Steve Pitman, Patrick Stinger, Ximena Valle, Adrienne Yancone

The final set of Visual Studies workshops extended the trajectory of ARCH 521/522 further into digital media, supporting new design directions by actively identifying the salient strengths and limitations of digital techniques. A series of two-

day sessions were held at critical points in the development of the studio project in ARCH 601, informing the studio work with digital techniques. The sequence of exercises built on each other to nurture a synthetic understanding of space in three dimensions and a mastery of the skills required to both project and simulate its representation in two dimensions. Rather than limit it to topological surfaces or animation-driven investigations of complex forms, the drawings were seen as a performative locus: visual repositories of data from which information can be gleaned, geometries tested, refined and transmitted. Students were encouraged to experiment with media-specific techniques and create hybrids by alternating and combining virtual and material techniques.

ARCH 631 Technology Case Studies I, Lindsay Falck

This course focused on current trends in technology being developed in the construction of buildings. In some cases, the emerging technologies involve new techniques for processing or assembling previously used materials, as with structural glass walls, whereas in others, totally new materials and processes of production are evolving, as with composite materials, such as carbon-fiber and resins formed and processed in autoclaved molds. The course also examined the rapidly changing methods of fabrication and on-site assembly of construction components, as in the CAD/CAM processes. These emerging technologies relate to structural components, enclosure components for roofs and walls, service and environmental control components and to the processes of fabrication and on-site assembly techniques. Emphasis in the case studies presented by visiting lecturers and faculty was on the holistic nature of the design and construction processes. This extended into the assignments undertaken by students in their analysis of a selected project, where all phases of design and buildings were studied.

ARCH 632-001 Deployable Structures, Mohamad Al Khayer

This course introduced the rapidly growing field of deployable structures through hands-on experiments conducted in workshop environments. The course provided an introduction to the history, theory and application of deployable structures in two parts: the first part consisted of a workshop that examined geometric studies of Platonic and Archimedean solids and space filling geometries; topology and morphological transformations; studies of different mechanical joints; computer visual analysis of the structural behavior of deployable structures; computer simulation of the deployment using Visual Nastrand; build basic deployable structure with link, skeletal and continuous members. In the second part of the course, each student developed and examined a deployable structure derived from a real case. The final assignment was the construction of a to-scale physical working model and its computer simulation.

ARCH 632-002 Simulation and Design, Yun Kyu Yi

Simulation is the process of making a simplified model of some complex system and using it to predict the behavior of the original system. During the past decade, advancements in computer technology made it possible for building simulation to be part of the design process. This course provided students with an understanding of building design simulation methods, hands-on experience in using computer simulation models and exploration of the technologies, underlying principles, and potential applications of virtual environments (virtual reality)

as a simulation tool in architecture. State-of-the-art computer models for thermal, lighting and acoustic analysis were introduced while the application of these models in architectural design were explored. A building was analyzed throughout the semester in the following areas: climate and site analysis; energy and passive solar systems; lighting and daylighting systems; acoustic systems; virtual visualization and design integration.

ARCH 632-003 Surfaces/Effects, Cathrine Veikos

The subtle and dynamic effects of the building surfaces of recent works by architects James Carpenter, Jun Aoki, Kenzo Kuma, Sejima + Nishizawa/SANAA, and Herzog and de Meuron are achieved through well-orchestrated details grounded in built reality. The perceptual effects of a building surface as a whole are directly related to the design of its elements of construction, its specific material and tectonic assemblies. Initial research identified and examined the possibilities for organizing and structuring perception through the design of surfaces. Lecturers demonstrated a range of effects created by selected architects and installation artists and examined how these effects are produced. The seminar was conducted as a workshop where students developed digital and material models towards the design of their own dynamic, environmentally responsive surfaces. These proposals were reviewed and discussed with a series of design consultants. The seminar/workshop not only addressed materials but their integration into building systems. The class reviewed requirements and criteria for double-skin facades, exterior, interior and interstitial solar shading, natural (buoyancy-driven), forced (mechanically-driven) and mixed ventilation, as well as experimental proposals.

ARCH 632-004 Finding Sustainable Form, Kevin Pratt

This course explored both the thinking that underlies sustainable design and the methods of analysis that are employed in the design of sustainable buildings. It investigated ways of understanding the dynamics of specific sites, including a close study of the convergence of ecological, climatic, tectonic and social systems that create architectural context. The primary focus was on using both theory and specific analytic techniques, including thermal & solar analysis, ecological footprinting, microclimatic computational fluid dynamics, and stochastic lighting simulation, to build a generative brief describing the sustainable potential inherent in such a context. It then examined how this brief can drive landscape design, formal development, material selection, and the design of building services, leading to the creation of an integrated, holistic sustainable architecture.

ARCH 632-005 High Performance Materials and Systems, Mark Igou

This course explored how traditional and cutting edge materials in conventional and non-conventional applications are used in building assembly design. Students were exposed to actual case studies presented by scientists, engineers and fabricators to convey the decision making process of how to arrive at innovative, high performance design solutions for building assemblies and systems. Students participated in collaborative teams with outside professionals to develop and build their own high performance materials and building systems. Discussion topics ranged from "The Fundamentals of Performance Design" to the "Exploration of Material Innovation." These topics were overlaid with how and why the construction industry operates

and what strategies are available to architects in order to realize these innovative solutions. Techniques such as "technology transfers" from other industries were explored to maximize innovation potential.

ARCH 638-001 Building Acoustics, Neill Woodger

This course began with an introduction to the fundamentals of acoustics including sound propagation, sound representation and measurement, sound transmission and associated materials, sound absorption and related materials, and reverberation time. After covering these fundamentals, the course covered the history of the development of performance space, principles of acoustic design of theatres, opera houses and concert halls. The implications of currently developing construction technologies, materials and design methodologies for the future of architectural practice relative to acoustic design were considered.

ARCH 638-002 Building Skins, Alberto Cavallero

This course focused on the parameters guiding the design, analysis and construction of high-performance building enclosures. A heuristic methodology formed the core of the coursework: by designing a small portion of a wall for an actual project for the FDA, we critically studied the entire process toward the realization of a sophisticated enclosure. During the exercise, a series of lectures allowed the class to apply a widening set of fundamental structural, constructive and thermal criteria, through a selection of materials, conceptual estimating and scheduling, testing procedures and finally to construction. The result of the exercise was intended to be both experimental and believable.

ARCH 638-003 Building Systems, Richard Farley

Building systems exert a growing influence on architectural design, particularly in America. This course examined how evolving technologies in mechanical engineering influence our work as architects, designers and planners – exploring a range of topics that have enormous cultural and technical implications for architecture, landscape and urban design. Each week, the seminar focused on a different building topology, considering how its systems and infrastructure are driven by specific functional requirements. The class traced both current and emerging techniques within each typology with a special emphasis on areas for design innovation.

ARCH 638-004 Biotechniques, Bill Braham

This course examined the ecological nature of design at a range of scales, from the most intimate aspects of design to the largest infrastructures, from the use of water in a bathroom to the flow of traffic on the highway. It is a first principle of ecological design that everything is connected, and that activities at one scale can have quite different effects at other scales, so the course identified useful and characteristic modes of analyzing the systematic, ecological impacts of design work, from the concept of ecological footprint to market penetration and market share. The broader goal of the course was to explore the historical development and broad premises of ecology and systems theory.

COURSES / REQUIRED

ARCH 638-005 Component Based Architecture, Michael Stacey / Tim MacFarlane

This course was an introduction to the potential for the use of contemporary technology in the creation of high quality architecture. It explored the materials and manufacturing process that result from the industrial revolution, the inventive 20th century and the cutting edge of contemporary construction. Focused on offsite manufacturing, the components examined materials ranging from those known for millennia to 'emergent' materials, from glass through superplastic aluminum to polymer composites. This course promoted a direct engagement with the means and methods of construction, advocating a creative dialogue with industry.

ARCH 671 Professional Practice I, Brian Kimura

This course is the first of a two-semester workshop that familiarizes students with the organizational, institutional and legal contexts for practice. It opened doors for students through ties to leading practitioners and encouraged critical reflection on the nature of architecture practices today. This initial workshop focused on the organizational design of a range of contemporary practices. Students developed an understanding of the logics of practice by taking three separate field trips including visits to eighteen firms.

ARCH 672 Professional Practice II, Charles Capaldi

This course is the second workshop on professional practice and addressed the organizational, institutional, and legal context of architectural practice. It studied the building process from the viewpoint of the different participants. Students developed appreciation and understanding of the importance of the relationships between the key 'players' in the building process through panel discussions with clients, consultants, contractors and fabricators. They explored the different roles of these players and asked how each figures into the building process as a whole.

ARCH 772 Professional Practice III, David McHenry

This course, the third in a sequence in professional practice and procedures, focused on the nature of projects in the context of activities within an architect's practice and on the idiosyncrasies of managing multiple projects. Detailed studies of the legal, financial, marketing, management and administration issues associated with the different forms of office proprietorship were studied. The special set of contractual and ethical obligations of the architect, particularly in response to client needs and safety, are examined. Codes, standards and regulations and their relationship to the different activities in the practice of architecture were presented.

ARCH 811 Advanced Theory I: Architecture, Climate and Culture, David Leatherbarrow

This course is to provide students who are embarking on a career of scholarship in architecture a first introduction to some of the principal issues and writings of the tradition. In addition to introducing themes and texts, this course aims to help students develop the practices that are typical of scholarship, the forms and habits of scholarly inquiry. To limit, somewhat, the abundance of thematic and historiographic material that could be covered the course also has a topical focus, signified by its

title: Architecture, Climate, and Culture. Part of our aim was to consider the potentials for conflict and agreement among these concerns: how the conditions that architects do not design affect those they do. A second task was to discover antecedents for concepts and insights discussed under the popular headings of "ecology" and "sustainability." Our working premise was that these concerns are not all together new to architecture.

ARCH 812 Advanced Theory II: Discourse Networks circa 1800-2000, Helene Furjan

For Benjamin and Giedion the present cannot be understood without a knowledge of history—typically for both of them an "ur" history that prefigures, indeed relentlessly drives towards, the present - but history cannot be understood without its framing within the context of the present moment. This course took this proposition seriously, operating in a constant feedback between past and present. It raised the question of history: of the significance of history, historicity and historiography to contemporary practice. A history of the 18th through 19th-centuries may seem to have little connection with our own moment, but the goal of this course was to point to the ways in which earlier histories of the discipline may continue to hold resonance with the contemporary. Topics included effect, mood and atmosphere, the shift from types to genotypes, sensation and dynamics as equally characteristics of the sensing subject and the built landscape, organicism and the role of biology, spectacularity and immersive experiences, techniques of vision and visibility, systems logics and part to whole relations, and analytics of the urban.

COURSES / ELECTIVE

ARCH 711-001 Informal Cities, Daniela Fabricius

This course approached 'informality' as a working term that requires further investigation. The class looked into the economic origins of the term and its related concepts, while simultaneously discussing contemporary informal conditions, particularly those taking place in Latin American cities. Students considered how informality emerges in neoliberalism, globalization, warfare, political movements, media technology and design. By exploring the aesthetic, political and theoretical implications of 'the informal' we hoped to collectively develop a broader and more complex understanding of a term that is so relevant today.

ARCH 711-002 Mies van der Rohe, Detlef Mertins

An in-depth examination of the architecture and thought of Ludwig Mies Van der Rohe (1886-1969) focusing on understanding the mode(s) of practice that he developed during his long career. Since Mies has often been miscast as a proponent of a universalizing and instrumental rationality, this seminar used his engagement with philosophy, theology, science, the philosophy of technology, aesthetics, art history and urban theory to clarify his position. As in Dada, Constructivism, or the critical realism of Walter Benjamin, Siegfried Kracauer, or Romano Guardini, Mies saw no choice but to accept the modern world as historically given and treat it as "a task," a site of engagement. The seminar explores how Mies sought to intervene in the historical transformations of a world dominated by science and technology - the destruction of experience, the domination of nature, and the eclipse of culture. Through close readings of selected buildings in relation to their historical and discursive contexts, the seminar identified the modus operandi Mies developed - promoting the emergence not only of a new architecture, but of new ways of living, new modes of experience, and a critical ethics of self-reflection, self-determination and self-construction "

ARCH 712-001 The Philosophy of Materials & Structures, Manuel DeLanda

This course examined concepts in materials science, stressing not only the usefulness of this knowledge for the purposes of design but also its intrinsic interest as a basis for a technically sound philosophy of matter. The course was shaped by the belief that architects benefit from a more detailed philosophical knowledge of the theoretical principles behind structural engineering. At the same time, it was informed by the idea that the creative use of computer software and digital simulations would benefit from additional philosophical resources. Specifically, the course highlighted new software that simulates biological evolution (so-called 'genetic algorithms' that may be used to 'breed' new architectural designs) and illustrates its value in the practice of engineering. The course integrated insights from two different areas crucial to contemporary design: material science and engineering, on the one hand, and computer simulations involving a host of new 'virtual materials' such as NURBS surfaces, particles and metaballs, as well as the intersection of these with the new evolutionary software.

ARCH 712-003 Architecture and Race, Charles Davis

This course introduced students to the way that architecture and race intersect in architectural history, architectural theory and architectural form. The class provided students with a working knowledge of the most prominent definitions of race from the

Enlightenment to the postwar period. This course primarily established the ways that Western architectural thought formalizes architecture and race, but non-Western cultures were analyzed in guest lectures and case studies.

ARCH 712-004 Contemporary Japanese Architecture, Stephanie Feldman

This course provided an in-depth exploration of contemporary Japanese architecture from Meiji to the present. Informed by an historical overview of Japan since the mid-nineteenth century, the class examined the innovative and challenging work of Japan's most prominent architects and placed it within the broader contexts of urbanization and globalization. Classes were organized thematically, and addressed topics such as culture and design, retail, construction technology, mega-projects, urban sprawl, prefab, and technology. A number of distinguished scholars and architects from the US and Japan participated as guest lecturers.

ARCH 717-001 Self-Organization & Dynamics of Cities, Manuel De Landa

Cities are among the most complex entities that arise out of human activity. The process through which some cities (Versailles, Washington DC) emerged is largely planned down to the details of architectural style by a human bureaucracy. Other cities, such as Venice and its labyrinthine system of streets, emerged spontaneously without any central agency making the relevant decisions. But even those cities in which urban structure was the result of a deliberate act of planning, house many processes which, like Venice, represent the spontaneous emergence of order out of chaos. This seminar examined a variety of these processes, from markets to symbiotic nets of small producers, from epidemics of urban diseases to the creation of new languages and urban dialects. It also explored the interaction between these self-organized phenomena and centrally controlled processes. Through this course, students were able to gain understanding of far-from-equilibrium thermodynamics and Artificial Life, considered in concert with new historical approaches to urban development, particularly those of Fernand Braudel, in which the physical and biological aspects of urban life are given as much attention as the social and linguistic ones.

ARCH 718 Japanese Architecture, Nancy Steinhardt

This course is an introduction to the visual, aesthetic, historical, religious, philosophical, and symbolic aspects of Japanese structures from earliest times to the mid-19th century. Through a discussion of shrines, temples, palaces, tombs, cities, and gardens the student explored what makes Japanese architecture distinctive and how the traditions of Japanese architecture have evolved over time.

ARCH 719 Archigram and its Legacy: London, a Technotopia, Annette Fierro

It was the contention of this research seminar that many of the visionary objectives of the 1960's counter-cultural group Archigram neither began nor ended with the formation and dissolution of its membership and its brief stint of kitchen-counter publications. Certainly the unconventional, exaggerated technologies so much a vehicle of Archigram's rhetorical mission have re-emerged repeatedly through the built work of

COURSES / ELECTIVE

the British Hi-Tech in the last 40 years, whose domination of London's architectural scene is without parallel in the order of world cities and whose allegiance to the expressive potency of advanced technology has seduced, provoked and bewildered audiences of every type. This course delved deeply into the particular siting of Archigram's influence with the British Hi-Tech, studying effects wrought as visionary architecture was made tangible, probing into actual technologies of these contemporary buildings as the thinking behind various excesses were probed. The course also examined buildings on a case study basis by examining many other of Archigram's visionary objectives and the often non-causal manifestation of these in contemporary London. This course acquainted itself with Archigram through contemporary London and London through Archigram's visions. This entailed the construction of a network of influences and eventualities, in concept paralleling the invasive and often subversive infrastructures proposed by Archigram itself. Through a series of readings, presentations and discussions, we wove together a series of these networks - from relationships to urban infrastructures, especially transportation and communication technologies, to precedents in Victorian engineering, to influences of Gothic literature and 60's science fiction, to ideas of event and happening, to other radical movements contemporary to Archigram's rise and demise, especially Superstudio and Archizoom in Italy and the Situationists in Paris.

ARCH 722 Between Line and Shadow, Marion Weiss

The making of architecture is executed through the reading of lines, mathematically described to indicate the boundaries and relationships of materials. Central to the act of drawing is the act of invention; illusion precedes realization. Line, surface, shadow, and perspective, explored through different media, are the language of inquiry. As a laboratory using both analog and digital media, the course tested how modes of representation can reveal qualitative aspects of spatial propositions. The course was organized as series of loops between media, layering and capturing their intrinsic effects and intensifying the potential for new expression. A series of investigations paralleled discussions with artists and architects exploring representations of space and form; a field trip to New York to visit selected galleries, artists' studios and architecture offices provided a window into the relationship between the instruments and media utilized to project built form and the preceding propositional representations. This course engaged the intuitive and ephemeral with the highly precise. The exchanging of surfaces and media explored the relationship between the goals of a project and the media of exploration, engaging the process of conceptualization with the process of drawing, recognizing that the act of drawing and the artifact of the drawing invite distinct possibilities for transformation.

ARCH 726 Furniture Design, Douglas Fanning

The course introduced strategies for designing furniture. Students covered the full range of design processes starting with small scale furniture production (hand-crafted one-off design and customized built-in furniture) to small batch production through mass production processes. This course examined the history of furniture design and fabrication and how various scales of production and manufacturing influence design decisions. Within the scope of the set projects, students were encouraged to be inventive and develop a personal response. This studio stressed a hands-on approach, where students worked within their skill level, time constraints and resources to achieve the best possible design. This course

gave students an opportunity to intensively investigate material, structure, connection and use and to synthesize them into a highly finished design. The limited scale and demands of furniture design reinforced fundamental issues for design and gave students a greater awareness of architectural design.

ARCH 732 Building Systems Integration, Ali Malkawi

The interrelationships of environmental control systems were explored by means of building type studies. Innovative systems are emphasized. Projects such as residential, educational and commercial buildings, office and assembly buildings, and facilities for research and manufacturing were analyzed in detail. The students investigated the principles of "high performance" or "integrated" buildings and how to apply these principles in design. The relationship between energy conservation and the principles of initial building cost versus life cycle costs were studied.

The first part of the course analyzed the systems of several existing "high performance" buildings. This study was accompanied by lectures about typical system components and building skins. Visits to several buildings helped students understand the integration of these systems. The second part of the course was a study of a single building. The layout of this building was provided and the work began with a proposal for the building envelope. Based on this design and the functional needs in the building, the environmental control systems were developed and applied through simplified computational simulations.

ARCH 734 Architecture & Ecology, Muscoe Martin

Architecture is an inherently exploitive act—we take resources from the earth and produces waste and pollution to make buildings. The construction industry is one of the single largest producers of greenhouse gas emissions in the United States as well as in other industrialized economies. Over the past ten years a growing awareness of the negative environmental consequences of construction has led many designers to look for ways to change how we design and build in order to lessen these impacts. These efforts have produced a number of revised construction techniques, innovative design tools, new products and marketing strategies, and have begun to have a significant effect on the building industry. However, the mainstream design world, in the U.S., has been slow to incorporate these approaches into either architectural theory or practice. This course explored the evolving notion of "sustainability" as it relates to the practice of architecture. We discussed how concerns about energy conservation, resource efficiency, open space preservation and indoor environmental quality are affecting the design of buildings. We learned to track the ecological scale effects of architectural design decisions. We critically reviewed the currently accepted metrics of sustainability including the LEED® Green Building Rating System, the Ecological Footprint and other indicators. We investigated the integral connections between urban design, landscape architecture and hydrological engineering and their impact on the environmental impact of development.

ARCH 736 Traversing Textile Hierarchies, Jenny Sabin

As one traces the technological and cultural history of weaving, a link is revealed between the punch card technologies used to automate the Jacquard looms of the mechanical age and the early binary systems used for computation in the first computers. This link is rooted in the binary patterning system

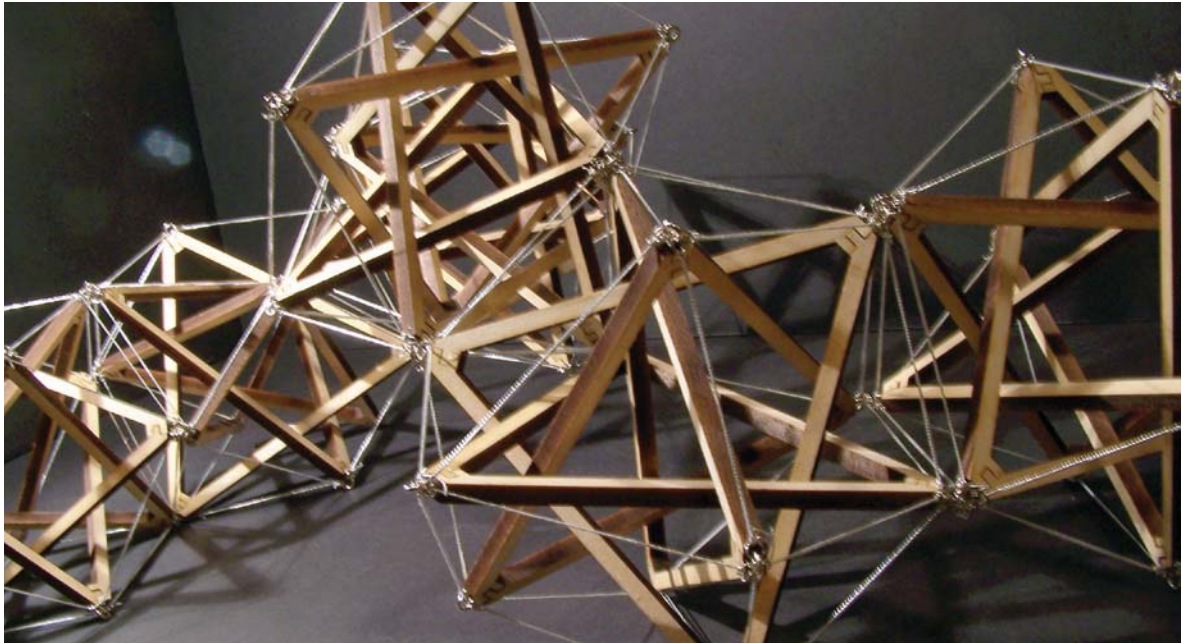

1 01 11 00 01	1 01 01 11 11	1 01 10 11 11	11 00 1 00 11	10 00 11 01 1	00 01 10 00 11
10 1 01 10 00	10 0 10 00 00	10 1 00 01 01	10 01 1 01 10	10 01 10 11 00	10 11 11 01 00
11 10 1 01 11	11 00 1 01 10	10 01 1 01 10	10 00 11 00 01	01 11 00 1 10	01 11 00 11 10
00 01 10 1 01	11 00 10 0 10	10 10 00 1 01	10 10 0 01 10	00 1 01 10 11	00 10 11 11 01
10 00 11 10 1	11 00 01 01 1	11 11 01 10 1	11 00 1 00 11	11 10 1 00 01	11 00 01 10 00

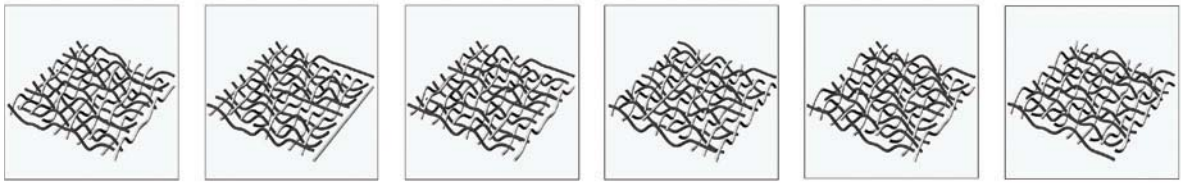
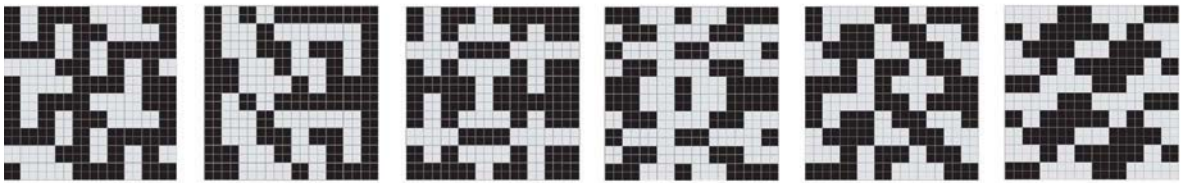

COURSES / ELECTIVE

of warp and weft; its configuration is a weave. This relationship is important to architecture now because it links the digital with the material through a systemic binary patterning system that engages a hybrid textile tectonic. This course traversed textile hierarchies by taking up a diverse sequence of thematic explorations at a range of scales and applications. This course was largely composed of a sequence of workshops where regular design problems were issued and culminated in a series of digital and fabricated physical models.

ARCH 738 Ecologies: Organisms and Environments, Rhett Russo

Ecology as it pertains to the field of biology is the study of organisms and their interactions with their environment. This course investigated four territories under the umbrella of ecology, loosely categorized as; behaviors, materials, environments and ethics. With the exception of ethics, all of these topics were investigated through their theoretical foundations in the field of biology and chemistry. Central to this discourse was the question; what can architects glean from the elegance of nature, both in practice and in concept? and what are the necessary political and scientific allegiances that will be required for interdisciplinary design? We looked to the forerunners in these fields for inspiration and the technologies that are forming around their research. Students also looked at how design practice is broadening to include interdisciplinary teams comprised of biologists, chemists and designers in unprecedented ways.

ARCH 739 Building Pathology, Michael Henry

This course addressed the deterioration and failures of buildings and their component systems. It included the technical aspects of materials and building failures, as well as the social and economic forces that also affect the fate of a built environment. Students were exposed to the techniques and vocabulary of construction, building failure assessment, restoration processes, and the techniques and methods of monitoring and testing buildings. Case studies were reviewed. For all of these topics, the course explored the various ways buildings deteriorate and fail physically, and the techniques of measuring and monitoring buildings for the purpose of assessing or foreseeing these changes.

ARCH 741-001 Computational Design in Architecture, Chris Lasch

This course explored the language and structure of computational design and its potential for architecture through the deployment of the algorithm as an organizational device. If architecture is an extended process of formation, then before ideas coalesce into a definitive form there must exist some undifferentiated state free of any organization. The moment any sort of development is imposed onto this formless matter it begins to enter the realm of substance, organization, and material. This seminar focused on the rules that exist in this hypothetical "pre-material" state that influence its movement into the realm of the material. An algorithm is simply a procedure written out as a finite series of steps and while most algorithms are designed for automation, increased productivity and efficiency, there is another class of algorithms that are not aimed at producing predictable results but rather initiating generative processes that yield unpredictable properties, unfamiliar orders, and behaviors. Though not an architectural design course in the strict sense, this class began to expose

implications that computational methods hold for architectural design practice. Students went "under-the-hood" to transcend the factory-set limits of their computer software, using scripting to operate on geometry and procedure directly. This alternative type of engagement asked students to reevaluate established design concepts as the computer became not just a new way to explore something already known, but an instrument with which to explore the unknown.

ARCH 741-002 Generative Models, David Ruy

This seminar was part of an ongoing experiment into generative models of design. The work focused on algorithmic information theory and the history of computation to develop concepts and techniques attuned to the problem of form generation after the computer. Though the term "generative model" is now commonly used to herald the provocative powers of digital design, its literal connotations are surprisingly esoteric and problematic. Life is generative. The claim that architecture can incorporate a generative model implies that architecture itself has the capacity to be alive, autonomous, and have mind of its own. Why has this term entered into the language of contemporary architecture? And why would computer technology enable a generative model? What is the relevance of a generative architecture in society today? Theoretical and historical lectures supplemented an active experimentation with generative procedures. Topics covered in lectures included: the history of generative principles of form, the history of the computer and computation, computational models of form generation (L-Systems, Cellular Automata, and substitution systems), Algorithmic Information Theory, and Randomness. Students developed semester long projects documenting experiments culminating in a public exhibition of the final results.

ARCH 743 Form and Algorithm, Cecil Balmond and Jenny Sabin

The seminar illustrated examples of non-cartesian, non-linear geometries and forms, from their inception and conceptualization to their realization in the form of space, program, circulation and structure. It investigated the unit (cell, bit, module) and its relationship to the whole (body, program, building) and its environment within the context of generative and algorithmic design. It showed the organization of new forms of structure, demonstrating how these models can operate at various scales and levels in the built environments and investigated the role of material feedback in abstract systems. The seminar illustrated the power of numbers and number systems as means of generating form and structure and explained how new geometries and forms are generated through the use of tools, demonstrating how these tools are important instruments of design.

ARCH 744 Digital Fabrication, Ferda Kolatan

This course investigated the fabrication of digital structures through the use of rapid prototyping (RP) and computer-aided manufacturing (CAM) technologies, which offer the production of building components directly from 3D digital models. In contrast to the industrial-age paradigms of prefabrication and mass production in architecture, this course focused on the development of repetitive non-standardized building systems (mass-customization) through digitally controlled variation and serial differentiation. Various RP and CAM technologies were introduced with examples of use in contemporary building design and construction.

ARCH 752 Case Studies in Urban Design, Michael Larice

Through three case studies and a final project, this course explored several fundamentally different ways in which the urban design process is realized in this country: the campus as historical prototype and contemporary paradigm; the new community both modernist and neo-traditionalist; expansion/relocation of CBD; and urban/suburban in-fill. Particular emphasis was placed on the roles of planning, historic preservation and landscape architecture in the practice of urban design.

ARCH 762 Design and Development, Witold Rybczynski

Many factors affect architectural design, including architectural style, building technology, functional demands, social needs, and the forces of the marketplace. The examples discussed focus on the places where we live, work, shop and play. This course provides an introduction to the relationship between architectural design and real estate development. Topics included domestic design, planned communities, and new urbanism.

ARCH 765 Project Management, Chip Arena

This course introduced students to techniques and tools of managing the design and construction of large and small construction projects. Topics included project delivery systems, management tools, cost-control and budgeting systems, and professional roles. Cost and schedule control systems were described and case studies illustrated the application of techniques in the field.

ARCH 768 Real Estate Development, Asuka Nakahara

This course analyzed the development process in terms of the different functions performed by real estate developers and architects, and the interrelationships between these two professions. Emphasis was placed on property evaluation site planning, building design, underlying economics and discounted cash flow analysis.

ARCH 773 Local Knowledge: Architectural Culture, Indigenous Buildings and Settlements, Tony Atkin

This course studied architecture and landscapes that express the slow accretion of knowledge about a place—and that embody local conditions and culture in their form, materials, and technology. We concentrated on what Thomas Leslie calls “empirical”—the building up of a project or a design over time from the experience of its situation and the means available. We investigated indigenous buildings and settlement practices that have evolved in balance with natural and cultural processes, and how their forms profoundly express the world view and beliefs of their inhabitants. We studied the many remarkable ways that pre-industrial buildings and landscapes have modulated the external environment for comfort and safety, and how they take advantage of the beneficial thermal characteristics of their materials, orientation, and spatial arrangements. At the same time, we analyzed how the forms of buildings and settlements shape our perception of the world, and how we define and project ourselves into our surroundings. During the semester, the class traveled to northern New Mexico to investigate indigenous technology and materials at the Acoma, Zuni, and San Juan Pueblos first hand, and how we can apply

this beneficial knowledge of climate and place to contemporary buildings. We also visited the remains of ancestral Puebloan buildings at Chaco Canyon, where the “Great Houses” responded to their place through solar orientation and celestial alignments. Finally, we examined how many modern architects including Aldo van Eyck, Le Corbusier, Louis Kahn, and Sverre Fehn were inspired by the archaic forms of ancient buildings and indigenous cultures, and sought to incorporate this knowledge and these powerful forms into their work.

ARCH 780 Architecture in the Schools, William Braham

“Architecture in the Schools” is a 20+ year program of teaching architecture in Philadelphia area schools run by the American Institute of Architects. As a participant in the AIE (Architecture in Education) program, students have the opportunity to work directly with children in the classroom making an impact on their lives and on the future of our neighborhoods and cities. Students worked with a classroom teacher and a design professional to develop a weekly series of eight (1–1 ½ hour) interdisciplinary experiential lessons using the built environment as a laboratory to create stimulating new ways of seeing, learning, and doing.

NEWS

STANDING FACULTY

Cecil Balmond and the Advanced Geometry Unit (AGU) completed a radical design for the Coimbra Footbridge over the River Mondego in Portugal to much critical acclaim. In September 2006, Balmond and the AGU presented *Hedge*, an experiment in the use of geometry and modular materials to create new organizations of space. The popularity of the exhibition led to an opening at the Graham Foundation in Chicago. He also participated in the exhibition *Frontiers of Architecture I—Cecil Balmond* at the Louisiana Museum of Contemporary Art, Denmark. Publications included a special edition of *A+U: Cecil Balmond*, and an article in *Toyo Ito: The New "Real" in Architecture* entitled "Learning Ito." He was also featured in numerous publications including *Detail*, *Domus*, *Metropolis*, *The Architectural Review*, *Wallpaper* and *The New Yorker*, to name a few. Balmond was nominated for the European Union Prize for Contemporary Architecture, Mies Van der Rohe Award 2007, for the 2005 Serpentine Pavilion. He gave the Inaugural Goldstein Architecture, Engineering and Science Lecture at MIT, Cambridge.



William Braham published *Rethinking Technology: A Reader in Architectural Theory* (Routledge) with Jonathan Hale, of the University of Nottingham. This anthology provides a convenient single source for all the key texts in the recent literature on architecture and technology. Braham gave lectures at the University of Chicago, Virginia Polytechnic University, University of the Arts, Ritual Architecture and the Florida International University where he was named The Paul L. Cejas Scholar.

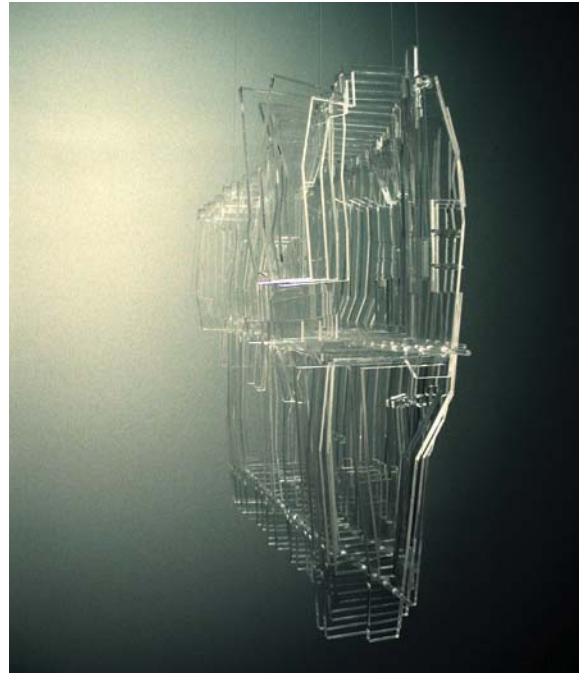
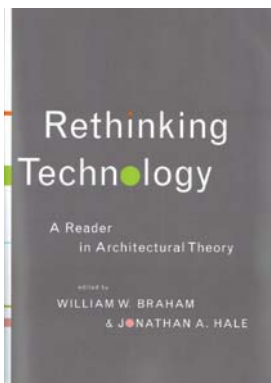

Winka Dubbeldam published a new monograph, *AT-INDEX* (Princeton Press 2007) and had work published in *A+U* and *Innovative Apartment Buildings* (Azur Corporation, Edition 2007), *Domus*, *Metropolis* and *Architectural Record*. Her firm, *Archi-Tectonics*, was awarded the 2006 IIDA/Metropolis "Smart Environment Award" for *Schein loft* in New York City. Dubbeldam co-curated *PAN* at the Frederieke Taylor Gallery in NYC with Helene Furjan and organized a related symposium at Columbia University. Other exhibitions included *New New York: Fast Forward* at The Urban Center, and *Skin and Bones, Parallel Practices in Fashion and Architecture* at the Geffen Contemporary at MOCA, Los Angeles and at The National Art Center, Tokyo. Winka lectured at the Art Institute of Chicago, Universidad de Puerto Rico, Center for Architecture, Georgia Tech, and Princeton School of Architecture. Her model for the project, *From Hardware to Softform*, was included in *Digitally Mastered*, an exhibition of recently acquired works at the Museum of Modern Art, New York.

Richard Farley was elected to the College of Fellows of the American Institute of Architects (AIA).

Helene Furjan participated in the 2006 ACSA West conference and 2007 ACSA National conference as session chair. She also served as panelist and contributed to a catalogue for the *Gen(H)ome* exhibition entitled *bio-architectures* (co-written with Peter Lloyd Jones). She co-curated *PAN* at the Frederieke Taylor Gallery in NYC with Winka Dubbeldam and was the moderator of a related symposium at Columbia University. Publications included an essay in *Interstices 7, Soft Space and Models*, 306090. Helene was appointed to the editorial advisory board of *Interstices* and as a reader for Routledge's architectural division. In 2006 she was appointed chair of Penn's Architecture Lecture and Event Series committee and as faculty advisor of the *VIA Annual* and *PennDesign Student Publications* committee.

Stephen Kieran and James Timberlake were awarded a 2006 AIA Honor Award for Davenport College, Yale University. They were also awarded the 2007 Honor Award from the Committee

on the Environment and the Award for Excellence by the AIA for the Sidwell Friends School, Washington, DC. Further AIA awards included a Citation Award for the Loblolly House, Honorable Mention for the Noyes Community Recreation Center at Cornell and an Honor Award for Interior Architecture for Pierson and Davenport College, Yale University. Their work has been published in *Wired*, *Record Houses*, *Wallpaper*, *HISE*, *Mark*, *GA Houses* and the *Washington Post*, among others. They lectured extensively, including recent talks at the Conference on Building Systems, Copenhagen; *Form Ecology and Place: The Shape of Green*, AIA National Convention; and University of Nottingham, School of the Built Environment.

Detlef Mertins participated in the symposium, "Uniformity and Variability," organized by Lars Spuybroek at the Georgia Institute of Technology, "Interact or Die!" which was part of the Dutch Electronic Arts Festival in Rotterdam, "Little Magazines" organized by Beatriz Colomina at Princeton University, and the "Deans' Forum on Engaged Practices" at the AIA New York. He gave a keynote address at the symposium, "The University and the City: Tapping the Potential for Ryerson's Master Plan" in Toronto. The interview, "Where Architecture and Biology Meet: Detlef Mertins interviewed by Arjen Mulder," appeared in *Interact or Die!* (Rotterdam, V2). Mertins published an essay in Paula Marincola's *What Makes a Great Exhibition* (PEI) and a review of Sandro Marpillero's book, *James Carpenter*, in the *Architect's Newspaper*.

Enrique Norton, TEN Arquitectos and WRT won the competition to redesign the historic Rutgers campus in New Brunswick, N.J. Rutgers. The firm participated in several international exhibitions including *La Rue Est a Nous Tous*, Val de Seine National School of Architecture, Paris; *New New York: Fast Forward*, The Urban Center; The Guggenheim Architecture, Bonn, Germany, and the AIA New York Design Awards Winners Exhibition, Center for Architecture. Enrique lectured at the Tulane University School of Architecture and the Catholic University of America. He served as a juror on award committees for "New Housing New York" and the Deutsche Bank.



Ali Rahim was Visiting Professor at Harvard University and the Louis Kahn Chair at Yale University. He lectured at University of Innsbruck, Innsbruck, Austria; Media Center Lume, Helsinki, Finland; Georgia Institute of Technology, Atlanta, Georgia; Tecnológico de Monterrey, Monterrey, Mexico; Yale University, New Haven, CT; Taliesin Frank Lloyd Wright School of Architecture, Scottsdale, AZ; The Royal Danish Academy of Fine Arts School of Architecture, Copenhagen, Denmark and Harvard University. Rahim's firm, Contemporary Architecture Practice, received the Outstanding Award in the 2006 Far Eastern International Digital Architectural Design Award (FEIDAD) Competition, a three-phase competition which encourages the exploration and definition of architectural design in the digital electronic age. Ali's book *Catalytic Formations: Architecture and Digital Design*, (Taylor and Francis) is now in reprint.



Witold Rybczynski received the 2007 Vincent J. Scully Prize by the National Building Museum, the 2007 Institute Honors for Collaborative Achievement by the AIA and the 2007 Seaside Prize by the Seaside Institute, Florida. He was also appointed Honorary Member of the American Society of Landscape Architects. Witold was an invited juror for the ULI JC Nicholls Prize and continues to serve on the Commission of Fine Arts. In April 2007, he published *Last Harvest: How a Cornfield Became New Daleville* (Scribner).

Cathrine Veikos published "To Enter the Work: Ambient Art" in the *Journal of Architectural Education* (JAE) 2006. Students in her Advanced Visual Studies course exhibited "The Evolving Drawing" at Gallery 222, Philadelphia. Veikos was co-Chair of the 95th Annual Meeting of the Association of Collegiate schools of Architecture 2007 and she participated in a panel on Visual Studies in Architecture. She lectured on Lina Bo Bardi at Philadelphia University and presented the Cass Gilbert Lecture, "Built by Hand" at the University of Minnesota School of Architecture.

Marion Weiss's firm Weiss/Manfredi was awarded the 2007 AUA New York City Gold Medal of Honor for distinction in the profession recognizing a body of distinguished work and high professional standing. Their Olympic Sculpture Park design for the Seattle Museum of Fine Arts opened to great acclaim in the national press. For that project, they received the 2007 Veronica Rudge Green International Urban Design Award, the American Institute of Architects' Honor Award and the American Society of Landscape Architects' Honor Award. They were invited to design the University of Virginia Arts Gateway to the University. Weiss's 2006 Penn design studio, *Resilient Topographies: A New New Orleans* was exhibited at the 2006 Venice Biennale. The firm also participated in numerous exhibitions featuring the Olympic Sculpture Park. Weiss/Manfredi were featured in dozens of articles and lectured worldwide.

NEWS

LECTURERS

Jonas Coersmeier's firm, Büro NY, lectured at the Digital Cities Conference at Bauhaus Dessau, Germany and was selected as finalist for the new Silk Road Cultural Park International Competition in Xi'an, China. Coersmeier was awarded the 2007 Nordrhein Westfalen Young Artist Award.

Scott Erdy and David McHenry's firm, ErdyMcHenry Architecture, was awarded a 2006 Honor Award for NoLi Housing, Philadelphia.

Hina Jamelle served on the Portman Prize Jury at Georgia Institute of Technology in December 2006 and was an external critic at Columbia, Yale and Harvard. She co-edited *Architectural Design: Elegance*, with Ali Rahim (Academy Editions/John Wiley and Sons). Her work was published in numerous publications including: *Architectural Record*, *Domus*, *Harvard Design Magazine*, *Architecture in Asia Now*, and *Young Architects Americas*.

Jennifer Leung exhibited and presented a lecture on her project "Baghdad Year Zero: the Strategic City and Its Architecture of Risk" at Artists Space and the Whitney Museum of American Art.

Shawn Rickenbacker exhibited digital drawings for "Drawn In" at the August Wilson Center's Gallery 209/9 Cultural District featuring works by black architects from Ghana, Nigeria, the Netherlands, Canada and the United States. Shawn also led a design workshop as part of the "Unspoken Borders" conference held at Penn by the PennDesign Black Student Alliance.

Jenny Sabin exhibited "Fourier Carpet" in the Connections exhibition at the University of New South Wales in Sydney. Working with the Advanced Geometry Unit at Arup, she was project designer and manager for the exhibition *H_edge*, with Cecil Balmond and Daniel Bosia, at the Artists Space in New York City. She was a senior tutor and speaker at the 2007 workshop and conference, "Generative Components," organized by Bentley Systems and held at the Cooper Union and Columbia University. Sabin presented a paper on her work at the 2007 Annual Conference of the ACSA. Her publications included exhibition catalogues for *H_edge* and *Connections*, an article in 306090, *Body Blankets*, and inclusion of her teaching in a special issue of *a+u* on Cecil Balmond.

Srdjan Jovanovic Weiss published *Almost Architecture* with Akademie Solitude and *kuda.iao*. He organized the conference "Europe Lost and Found" at the Columbia School of International Politics and co-organized the cross-disciplinary conference "Evasions of Power" at the University of Pennsylvania with the Slought Foundation. Weiss lectured at the Holzim Forum for Sustainability, Shanghai, and the Normandy School of Architecture in Rouen, France. He designed a collaborative exhibition with the visionary architect Yona Friedman at the Drawing Center, New York and exhibited at the Swiss Architecture Museum, Basel. At the invitation of Herzog & de Meuron Architects, Weiss spent the academic 2006/2007 year in H&deM office in Basel as an architect and research consultant. He is currently managing a collaborative research project between H&deM and AMO/OMA to speculate on the possible futures of the Haus der Kunst, Munich, a controversial building erected during the Nazi regime in 1937.



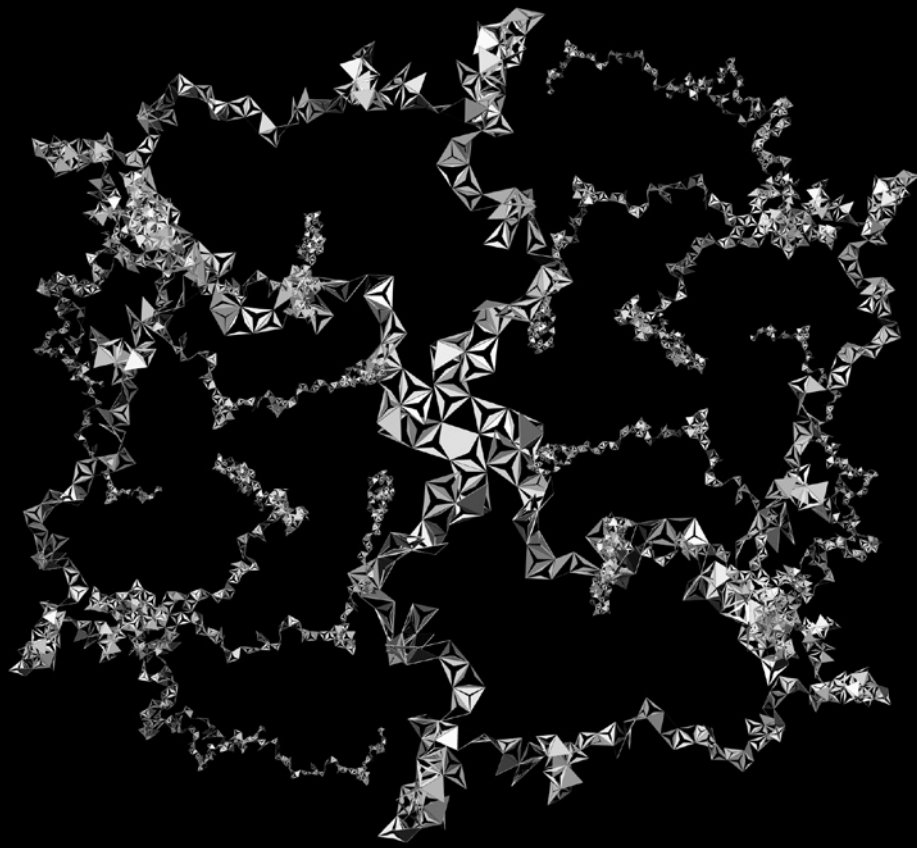

Nicolas Koff: ARCH 501 with Jenny Sabin: Growth Diagram, System #1

STUDENT NEWS

John Andrus, Brad Lebin, Ryan Lohbauer, and Jeff Tummelson were awarded First Prize in the first National Student Design Competition sponsored by the Ed Bacon Foundation. The competition asked for visions to transform Penn Center in Philadelphia, originally conceived by Bacon in the 1960s. Their project was entitled "Garden Artery: Seamless Streetscape."

Megan Born won the Kohn Pedersen Fox Traveling Fellowship in the amount of \$10,000. Her project included work from her ARCH 601 studio with Babak Bryan, Self-sustaining Urbanism Design Studio 3/Ecology + Technology, which integrated hydrological and structural systems. <image>

Mike Burlando, Dan Hammerman and Jonathan Kowalkoski won the 2006 ACSA Student Design Charette, Transforming Architecture—Designing with Brick in Philadelphia. With sponsorship from the Brick Industry Association, the ACSA held a 48-hour student charrette at their 2007 Annual Meeting in Philadelphia.

Amy Campbell and Clark Thenhaus, along with other PennDesign students, received the Honor Award for their 2007 competition submission to the United States Institute for Theatre Technology. The Penn team was pulled together by Campbell and included Penn Theatre students Samantha Lazar, Gisela Garrett, Evean Adelman, Josh Corn. Their project was called "Operation Arts—A Grassroots Initiative."

A multi-disciplinary team including Brandon Donnelly and Daniel Whipple were awarded honorable mention in the 2007 Urban Land Institute's Gerald D. Hines Urban Design Student competition. This year's competition study area connected downtown Los Angeles to Boyle Heights. Their team included students from Landscape Architecture, Business Administration and City Planning and their faculty advisor was Detlef Mertins.

Alexander Eisenschmidt, Ph.D. candidate, was a recipient of a 2006 Trustees' Merit Citation from the Graham Foundation for Advanced Studies in the Fine Arts. The 2006 Carter Manny Award carried a prize of \$10,000.

Peter Rae was designated one of 6 winners of the Storefront/Control Group Student Design Award 2007. "The Ocean Power Research and Development Center" was a project completed in Rhett Russo's spring 2007 research studio.

Ravi Srinivasen, Ph.D. candidate and Assistant Director of Development at the TC Chan Center for Building Simulation and Energy Studies was named one of the top 24 emerging environmental leaders in the Delaware Valley. The appointment includes a prestigious year-long fellowship program aimed at enhancing the capacity of the environmental movement.

PennDesign students were invited to participate in a multi-school/architectural firm exhibition in Beijing, China in *Emerging Talents, Emerging Technologies*, as part of the Architectural Biennial Beijing 2006. The students' projects were exhibited among 24 other schools and 48 professional firms. The students who participated included Justin Coleman, Amy Johnson, Jaime Lee, and Herman Mao (Faculty: Cecil Balmond); Boar Temelkuran (Faculty: David Ruy); Michael Samula (Faculty: Winka Dubbeldam); and Steve Pitman (Faculty: Annette Fierro and Ferda Kolatan).

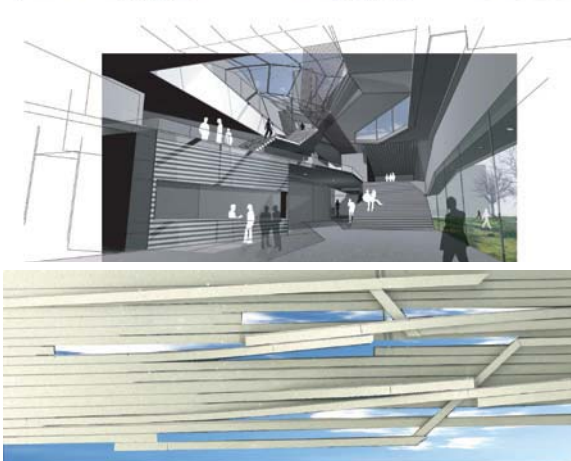

STUDENT PRIZES AND AWARDS

American Institute of Architects Henry Adams Medal
First Prize: Peter William Rae
Second Prize: Nicholas Hollot

Arthur Spayd Brooke Memorial Prize
Gold Medal: Peter William Rae
Silver Medal: Bradford A. Leibin
Bronze Medal: Lisa Margaret Schwert

Paul Philippe Cret Medal
Jackie C. Wong

Paul Philippe Cret Prize
David Schweim

Harry E. Parker Prize
Peter William Rae

Alpha Rho Chi Medal
Jackie C. Wong

Warren Powers Laird Award
Bridget Schmelzer

Charles Merrick Gay Scholarship
Carrie A. Bergey

Samuel K. Schneidman Fellowship
Andrew P. Lucia

Frank Miles Day Memorial Prize
Lily Jencks

Harlan Coornvelt Memorial Medal
Song-Ching Tai

Mario J. Romanach Fellowship
Megan M. Born

James Smyth Warner Memorial Prize
Andrew P. Lucia

Faculty Prize
Catherine Bonier

Walter R. Leach II Fellowship
Jacob Nicoll-Stoltzfus

T-Square Club Fellowship
Lauren MacCuaig

Mr. and Mrs. William L. Van Alen Traveling Fellowship
Ryan Keerns

Will M. Mehlhorn Scholarship
500-Level
First Prize: Melinda McMillan
Second Prizes: Alex Muller
600-Level
First Prize: William Caulin, Hollie Landela, Gabriela Sarhos,
David Schweim
Ph.D., M.S. Architecture
First Prize: John Sands

The Donald Prowler Memorial Prize
Emily Bernstein

Albert F. Schenck- Henry Gillette Woodman Scholarship
First Prize: Daniel Affleck
Second Prize: JaeYoung Lee
Honorable Mention: Vincent Leung, Kara Medow, Bridget Schmelzer

E. Lewis Dales Traveling Fellowships
Faris S. Al-Shathir
Carrie A. Bergey
Yasmin Bhombal
Megan M. Born
Anthony Caicco
Kwoktung-Anthony Chan
Todd M. Costain
Dane C. Danielson
Yuteki Dozono
Jason A. Easter
Lokkay Fan
Claire L. Fellman
Jonathan Fogelson
Carlos A. Fornos
Daniel M. Hammerman
Aaron A. Jezzi
Ryan L. Keerns
Kevin G. Kehler
Matthew D. Lake
Hwa-Seop Lee
Andrew P. Lucia
David J. Madrid
Robert A. May
Benjamin B. Muller
Misako Murata
Charles J. Nawoj
Jeffrey R. Olgin
Nerijus Petrokas
Jean-Baptiste A. Roufineau
Andrew G. Ruggles
Allison K. Schue
Elizabeth A. Sweeney
Ashley L. Wendela

2007 John Stewardson Memorial Scholarship in Architecture
First Prize: Lisa Margaret Schwert
Second Prize: Peter Rae
Honorable Mention: Stephen P. Boehmke, Juliet Yu-San Lee,
Jackie C. Wong

EVENTS

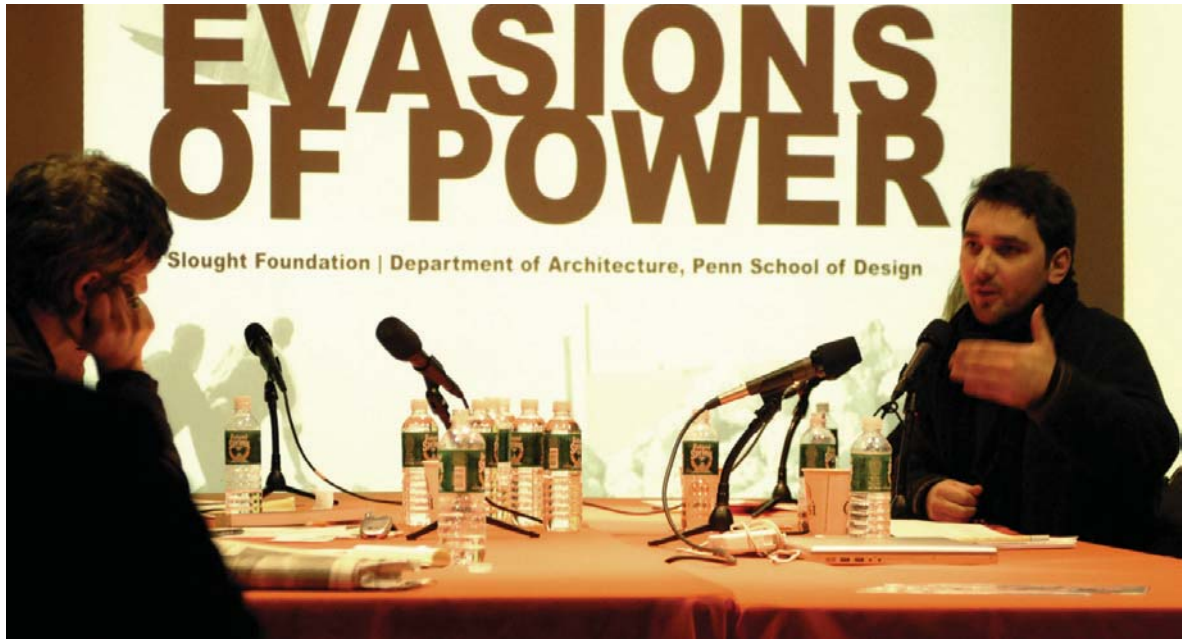

FALL 2006 LECTURE SERIES

Fertilizers: Eisenman/Olin in Conversation

Peter Eisenman, Eisenman Architects
Laurie Olin, Practice Professor of Landscape Architecture,
PennDesign; Olin Partnership
Julia Czerniak, School of Architecture, Syracuse University
September 20

The Tectonic Sensibility of Antonin Raymond

Kenneth Frampton, Ware Professor of Architecture, Graduate
School of Architecture, Planning and Preservation, Columbia
University
September 21

Penn Connects: A New Master Plan for the University

Dennis Pieprz, Sasaki Associates
October 25

Emerging Grid

Toyo Ito, Toyo Ito and Associates, Architects
November 2

Works

Winka Dubbeldam, Practice Associate Professor of Architecture
and Director, Post-Professional Program, PennDesign and
Principal, Archi-Tectonics
November 6

Convergences: New Technologies + New Designs

A series providing open discussion forum for PennDesign
faculty, students and guests that seeks to frame topical
disciplinary questions
Moderators: William Braham, Associate Chair and Associate
Professor, PennDesign; Ferda Kolatan, Lecturer, PennDesign;
Principal, su11 architecture + design

CONFERENCES

Architecture Bits —The NLSO Annual Conference

October 5–6
Opening Remarks: David Ruy
Roundtable 1:
Moderator: Sanford Kwinter
Participants: William Braham, Helene Furjan, Peer Davies, Peter
Lloyd Jones, Ferda Kolatan, Rhett Russo, Jenny Sabin
Roundtable 2:
Moderator: Peter Macapia
Participants: Robert Aish, Ben Aranada, Andrew Blumberg,
Daniel Bosia, Axel Kilian, Chris Lasch, Lars Hesselgren, Philip
Ording

Related Exhibition at Facilities and Real Estate Services,
University of Pennsylvania

Instrumenting a Plan for Complexity: Connecting Campus and City Through Visionary Urbanism

Student work from the spring 2006 PennDesign, Department of
Architecture Research Studio with Cecil Balmond and Jenny
Sabin

Generative Components Workshop
October 7–8

SPRING 2007 LECTURE SERIES

Architecture in Formation

Marcelyn Gow, Principal, SERVO; Lecturer, UCLA
January 29

Thickety Thick

James Corner, Professor and Chair of Landscape Architecture,
PennDesign; Principal, Field Operations
February 1

Tapered, Tilted, Twisted Towers

David Scott, Principal, ARUP NY; Chairman, Council of Tall
Buildings and Urban Habitat
February 7

This Whole Experiment of Green

Peter Timmerman, Faculty of Environmental Studies, York
University, Toronto, Canada
February 12

Contemporary City Making: Ruination, Nomadism and Fear

Lindsay Bremner, Chair of Architecture, Tyler School of Art,
Temple University
February 15

Layering of Architecture: SANAA's North American Museums

Florian Idenburg, Senior Associate, SANAA, Tokyo, Japan
February 27

Material Time

Nikolaus Hirsch, Wandel Hoefer Lorch & Hirsch, Frankfurt,
Germany; Unit Master, Architectural Association; Co-director,
United Nations Plaza Institute
March 22

Practices of Encroachment

Teddy Cruz, Principal, Estudio Teddy Cruz, San Diego; Associate
Professor, Public Culture and Urbanism, University of California,
San Diego
April 2

The Autonomous Language of Architecture is Doomed and Why Architecture School Should Teach More About Contracts

Joshua Prince-Ramus, Principal, REX-NY
April 9

Designing Complex Forms: Recent Work

Fumihiko Maki, Maki and Associates
Sponsored by Skidmore Owings Merrill, LLP and the Office of
the Dean, PennDesign
April 17

CONFERENCES

Association of Collegiate Schools of Architecture Annual Meeting

March 8–10
Keynote Lectures: David Leatherbarrow, PennDesign; Richard
Rogers, Richard Rogers Partnership, London
Co-Sponsors: University of Pennsylvania, Drexel University, Tau
Sigma Delta, the AIA and the ACSA

Unspoken Borders

March 30–31
A conference to ignite discussion on issues related to minorities
within the disciplines of architecture, city planning, fine arts,
historic preservation, and landscape architecture. More
specifically, this dialogue gave participants the opportunity to

discuss the tangible and intangible borders that are created, enhanced, or ignored by the various professions.

Organized and sponsored by the PennDesign Black Student Alliance

Keynote Speakers: Walter Hood, Principal, Hood Design; Mitchell Silver, Planning Director, Raleigh, NC

Session Moderators and Participants: Craig Barton, University of Virginia; Dr. Carla Corroto, University of Wisconsin, Whitewater; Milton Curry, Cornell University; Principal, OrbitMCAdesignstudio; Dr. David Diaz, UCLA; Sherman Fleming, ArtWorks Coordinator, Mural Arts Program, Philadelphia; Mario Gooden, Yale University; Principal, Huff + Gooden Architects Kenrick Ian Grandison, University of Virginia; Dr. Angel Nieves, University of Maryland; Gwendolyn DuBois Shaw, University of Pennsylvania; Shawn Rickenbacker, University of Pennsylvania; Principal, Rickenbacker + Leung

Evasions of Power

March 30–31

Organized by Srdjan Jovanovic Weiss, Aaron Levy, and Katherine Carl

Territories

Keller Easterling, Sanjay Krishnan, Laura Kurgan and Eyal Weizman, moderated by Srdjan Weiss

Institutions

Anselm Franks, David Kazanjian, Tom Keenan, Sarah Herda and John Palmesino, moderated by Katherine Carl

Interventions

Carlos Basualdo, Lindsay Bremner, Teddy Cruz, Deborah Gans, David Ruy, Nebojsa Seric Shoba, moderated by Helene Furjan

Networks, Netwar and Narratives

Samuel Weber, Catherine Liu, Peter Krapp and Eduardo Cadaya, moderated by Jean-Michel Rabate

Tracking Tactics and Rhetorics

Thomas Y. Levin and members of the Goldsmiths Centre for Architecture Research

Sponsored by the Department of Architecture, Slough Foundation, Department of the History of Art History, University of Pennsylvania; Goldsmiths Centre for Architecture Research, London; Eastern State Penitentiary, Philadelphia. Support for the forthcoming publication for *Evasions of Power* was provided by the Graham Foundation for Advanced Studies in the Fine Arts.

EXHIBITIONS

The Evolving Drawing: Visual Studies at the University of Pennsylvania

222 Gallery, Philadelphia

February 2–March 30

Student Work from 'Form + Algorithm'
Design Philadelphia 2007

Cecil Balmond and Jenny Sabin, instructors

April 12–22

CONVERSATIONS

Design-Research

Moderator: Helene Furján, PennDesign

Speakers: Sean Lally, Principal, Weathers; Rice University; Director, Energies and Matter Lab; Eran Neumann, Principal, OSA; Technion; Director, T_CODE at the Technion; Theodore Spyropoulos, Director, Minimaforms; Co-director, DRL, Architectural Association; Aaron Sprecher, Principal, OSA; Syracuse University, LIFE Lab_Syracuse

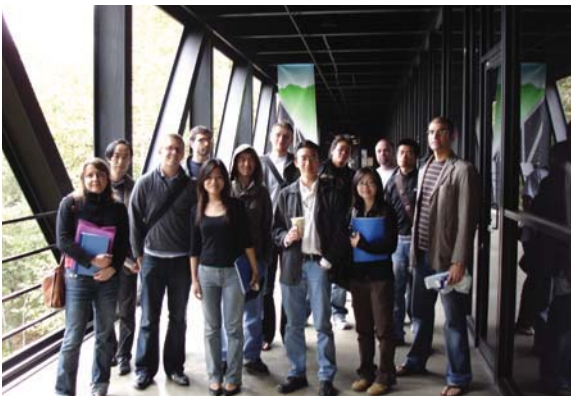



Peter Rae: ARCH 704 with Rhett Russo