



University of Pennsylvania
ScholarlyCommons

Technical Reports (CIS)

Department of Computer & Information Science

April 1991

Design of a Tool-Surrounding Compliant Instrumented Wrist

Thomas Lindsay
University of Pennsylvania

Richard P. Paul
University of Pennsylvania

Follow this and additional works at: https://repository.upenn.edu/cis_reports

Recommended Citation

Thomas Lindsay and Richard P. Paul, "Design of a Tool-Surrounding Compliant Instrumented Wrist", . April 1991.

University of Pennsylvania Department of Computer and Information Science Technical Report No. MS-CIS-91-30.

This paper is posted at ScholarlyCommons. https://repository.upenn.edu/cis_reports/373
For more information, please contact repository@pobox.upenn.edu.

Design of a Tool-Surrounding Compliant Instrumented Wrist

Abstract

Interaction between robot and environment is an extremely important aspect of robotic research. Compliance helps reduce the effects of impact when there is robot/environment interaction. To accomplish useful tasks, it is important to implement hybrid control; accurate position control is needed in unconstrained directions and accurate force control is needed in constrained direction. Force control can be more responsive with a compliant force/torque sensor [3], but positional accuracy is reduced with compliance. An instrumented compliant wrist device can be used to achieve both responsive force control and accurate position control. The wrist is connected in series between the end of the robot and the tool. The wrist device uses rubber elements for compliance and damping, and a serial linkage, with potentiometers at each joint, is used for sensing the deflections produced in the wrist. Several major improvements are proposed for the Xu wrist. The wrist can be designed to surround the tool, thus reducing the distance between the end of the robot and the end of the tool, thus reducing the distance between the end of the robot and the end of the tool. The compliant structure is redesigned for more even compliance, and the sensing structure kinematics are simplified. In this over, the compliance, kinematics, and accuracy of the wrist will be presented. Also, software for finding the wrist transform, and plans for the wrist are given.

Comments

University of Pennsylvania Department of Computer and Information Science Technical Report No. MS-CIS-91-30.

**Design Of A Tool-Surrounding Compliant
Instrumented Wrist**

**MS-CIS-91-30
GRASP LAB 258**

**Thomas Lindsay
Richard P. Paul**

**Department of Computer and Information Science
School of Engineering and Applied Science
University of Pennsylvania
Philadelphia, PA 19104-6389**

April 1991

Design of a Tool-Surrounding Compliant Instrumented Wrist[†]

Thomas Lindsay and Richard P. Paul

Abstract

Interaction between robot and environment is an extremely important aspect of robotic research. Compliance helps reduce the effects of impact when there is robot/environment interaction. To accomplish useful tasks, it is important to implement hybrid control; accurate position control is needed in unconstrained directions, and accurate force control is needed in constrained directions. Force control can be more responsive with a compliant force/torque sensor [3], but positional accuracy is reduced with compliance. An instrumented compliant wrist device can be used to achieve both responsive force control and accurate position control [6].

The wrist is connected in series between the end of the robot and the tool. The wrist device uses rubber elements for compliance and damping, and a serial linkage, with potentiometers at each joint, is used for sensing the deflections produced in the wrist. Several major improvements are proposed for the Xu wrist. The wrist can be designed to surround the tool, thus reducing the distance between the end of the robot and the end of the tool. The compliant structure is redesigned for more even compliance, and the sensing structure kinematics are simplified.

In this overview, the compliance, kinematics, and accuracy of the wrist will be presented. Also, software for finding the wrist transform, and plans for the wrist are given.

[†]This material is based upon work supported by the National Science Foundation under Grant No. BCS-89-01352, "Model-Based Teleoperation in the Presence of Delay." Any opinions, findings, conclusions or recommendations expressed in this publication are those of the authors and do not necessarily reflect the views of the National Science Foundation.

Contents

1	Introduction	4
2	Compliant Structure	5
3	Linkage Kinematics	9
4	Accuracy	12
4.1	Positional Accuracy	12
4.2	Hysteresis Effects	13
5	Wrist Software	13
6	Wrist Plans	16
6.1	General	16
6.2	Compliant Structure	19
6.3	Sensing Linkage	22
6.4	Electronics	28
7	Conclusion and Future Work	30

List of Figures

1	The Tool-Surrounding Compliant Instrumented Wrist	4
2	Compliant Structure	5
3	Compliant Structure Measurements. $L_1= 1.25"$, $L_2= 0.50"$	6
4	Rubber Element Placement	8
5	Serial Linkage Chain	9
6	Kinematic Skeleton	10
7	Side view of linkage structure	10
8	Top view of linkage structure	11
9	Top Plate	17
10	Bottom Plate	18
11	Compliant Structure - Exploded View	19
12	Compliant Structure Piece 1	20
13	Compliant Structure Piece 2	21
14	Sensing Linkage - Exploded View	22
15	Linkage Piece 1	23
16	Linkage Piece 2	24
17	Linkage Piece 3	25
18	Linkage Piece 4	26
19	Linkage Piece 5	27
20	Wrist Electronics	28
21	Power and Connections	29

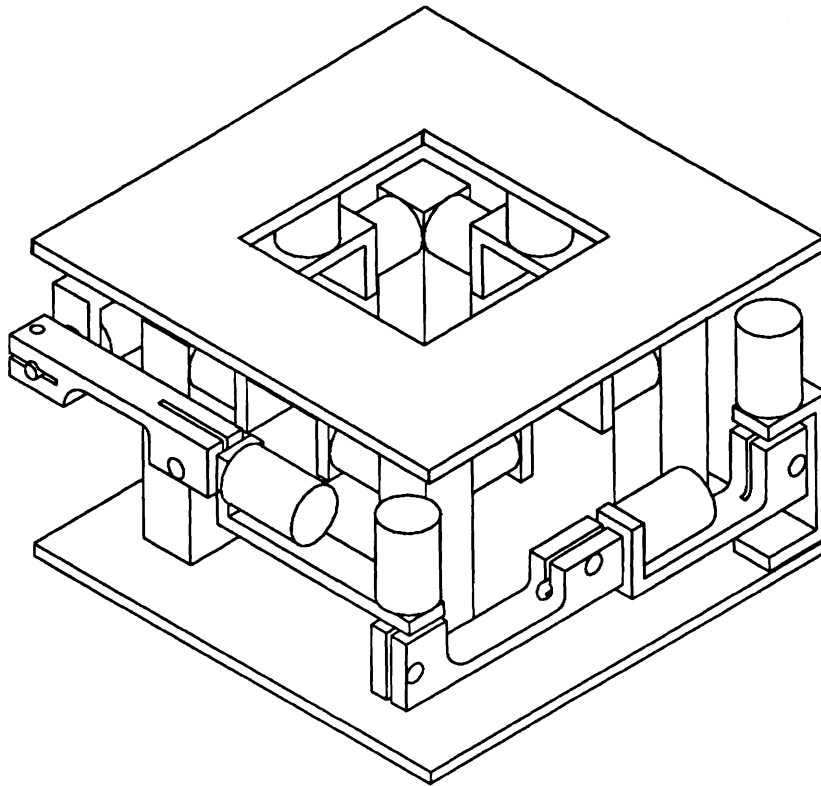

Figure 1: The Tool-Surrounding Compliant Instrumented Wrist

1 Introduction

The wrist outlined herein is a solution to a complex problem: compliance in a robot wrist is desired to reduce the effect of impacts between the robot and the environment, and to create a more responsive force control. However, a compliant wrist by itself has a limit on the effective stiffness of the manipulator in position control, and the exact position of the end of the wrist (and thus the environment, when in contact) is lost [5]. By instrumenting the wrist as shown here, though, both these problems are overcome. Active control can increase the stiffness of the system, and the position transform of the wrist is known. Using the instrumented wrist as a compliant force/torque sensor leads to more responsive force control than with a stiff sensor [3], and more accurate position control than with a compliant wrist [6].

The wrist is overall 4.25 x 4.25 x 3.0 inches high. A 1.75 x 1.75 inch tool can be mounted inside the wrist to a depth of 2.5 inches maximum, depending on the desired flexure of the wrist.

The rest of the paper is organized as follows: section 2 outlines the compliance of the wrist, and how it can be modified with different compliant elements, section 3 explains the sensing linkage kinematics, section 4 is a short analysis of the accuracy of the wrist, section 5 contains a simple software routine to compute the wrist transform, section 6 contains the mechanical and electrical plans for the wrist, and section 7 gives a conclusion including current research using the wrist and future work on the wrist.

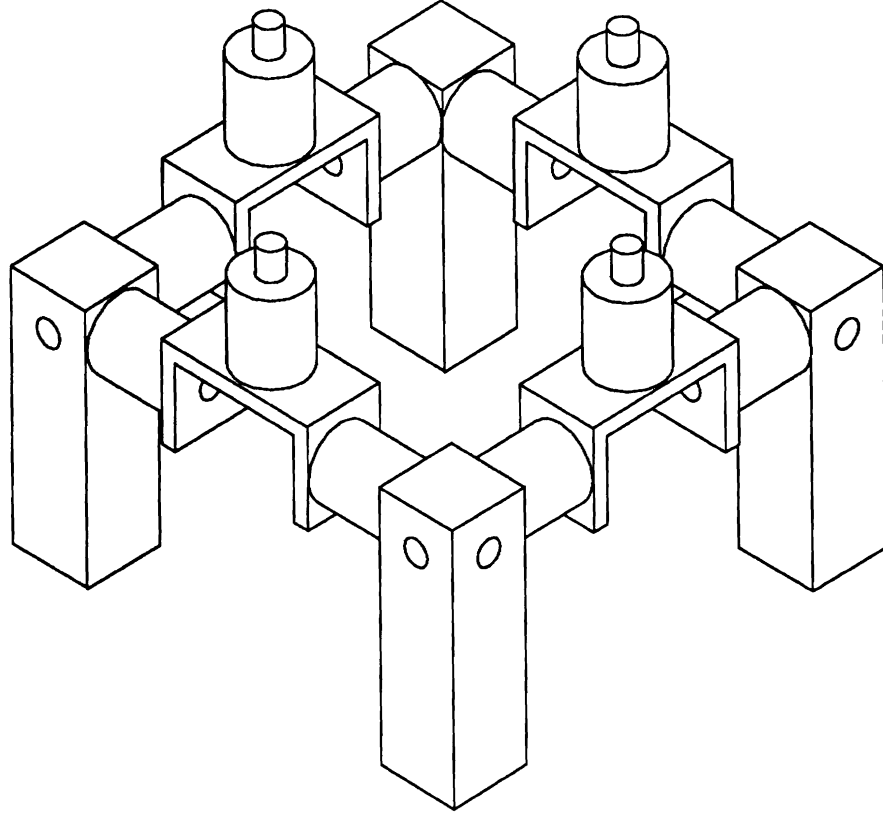

Figure 2: Compliant Structure

2 Compliant Structure

The compliant structure of the new wrist is composed of 12 rubber elements, which provide compliance and a small degree of damping. Figure 2 shows the design, with the bottom plate (attached to the robot) fixed to the four aluminum blocks at the corners, and the top plate (where the tool is attached) fixed to the four compliant elements (cylinders) at the top. The tool can then be partially enclosed in the middle of this structure. Because of the physical limitations of the compliant elements, forces on the wrist should stay below 3.0 lbs.

The stiffness in each direction can be approximated as follows:

$$K_z = \left(\frac{1}{4K_a} + \frac{1}{8K_r} \right)^{-1} \quad (1)$$

$$K_x = K_y = \left(\frac{1}{4K_r} + \frac{1}{4K_a + 4K_r} \right)^{-1} \quad (2)$$

$$K_\psi = \left(\frac{1}{4K_r L_1^2} + \frac{1}{8K_a L_1^2} \right)^{-1} \quad (3)$$

$$K_\phi = K_\theta = \left(\frac{1}{2K_a L_1^2} + \frac{1}{4K_r L_1^2 + 4K_r L_2^2} \right)^{-1} \quad (4)$$

$$+ \frac{1}{(K_{5r} + K_{6r} + K_{7r} + K_{8r} + K_{9r} + K_{10r} + K_{11r} + K_{12r})}^{-1} \quad (5)$$

$$K_x = \left(\frac{1}{(K_{1r} + K_{2r} + K_{3r} + K_{4r})} + \frac{1}{(K_{7a} + K_{8a} + K_{11a} + K_{12a} + K_{5r} + K_{6r} + K_{9r} + K_{10r})} \right)^{-1} \quad (6)$$

$$K_y = \left(\frac{1}{(K_{1r} + K_{2r} + K_{3r} + K_{4r})} + \frac{1}{(K_{5a} + K_{6a} + K_{9a} + K_{10a} + K_{7r} + K_{8r} + K_{11r} + K_{12r})} \right)^{-1} \quad (7)$$

$$K_\psi = \left(\frac{1}{L_1^2(K_{1r} + K_{2r} + K_{3r} + K_{4r})} + \frac{1}{L_1^2(K_{5a} + K_{6a} + K_{7a} + K_{8a} + K_{9a} + K_{10a} + K_{11a} + K_{12a})} \right)^{-1} \quad (8)$$

$$K_\phi = \left(\frac{1}{L_1^2(K_{2a} + K_{4a})} + \frac{1}{L_1^2(K_{7r} + K_{8r} + K_{11r} + K_{12r}) + L_2^2(K_{5r} + K_{6r} + K_{9r} + K_{10r})} \right)^{-1} \quad (9)$$

$$K_\theta = \left(\frac{1}{L_1^2(K_{1a} + K_{3a})} + \frac{1}{L_1^2(K_{5r} + K_{6r} + K_{9r} + K_{10r}) + L_2^2(K_{7r} + K_{8r} + K_{11r} + K_{12r})} \right)^{-1} \quad (10)$$

Below is a table of compression and shear stiffness for sample compliant elements. Note that in the current design, mount A was used for all positions on the wrist. Mount N occurs when no mount element is used for a site.

Mount [1]	K_a	K_r	comments
	lb/in (N/mm)	lb/in (N/mm)	
A	66.7 (2.63)	12.0 (.472)	mount used
B	92.3	17.6	
C	175.0	37.5	
D	228.6	50.0	
N	0.0	0.0	no mount

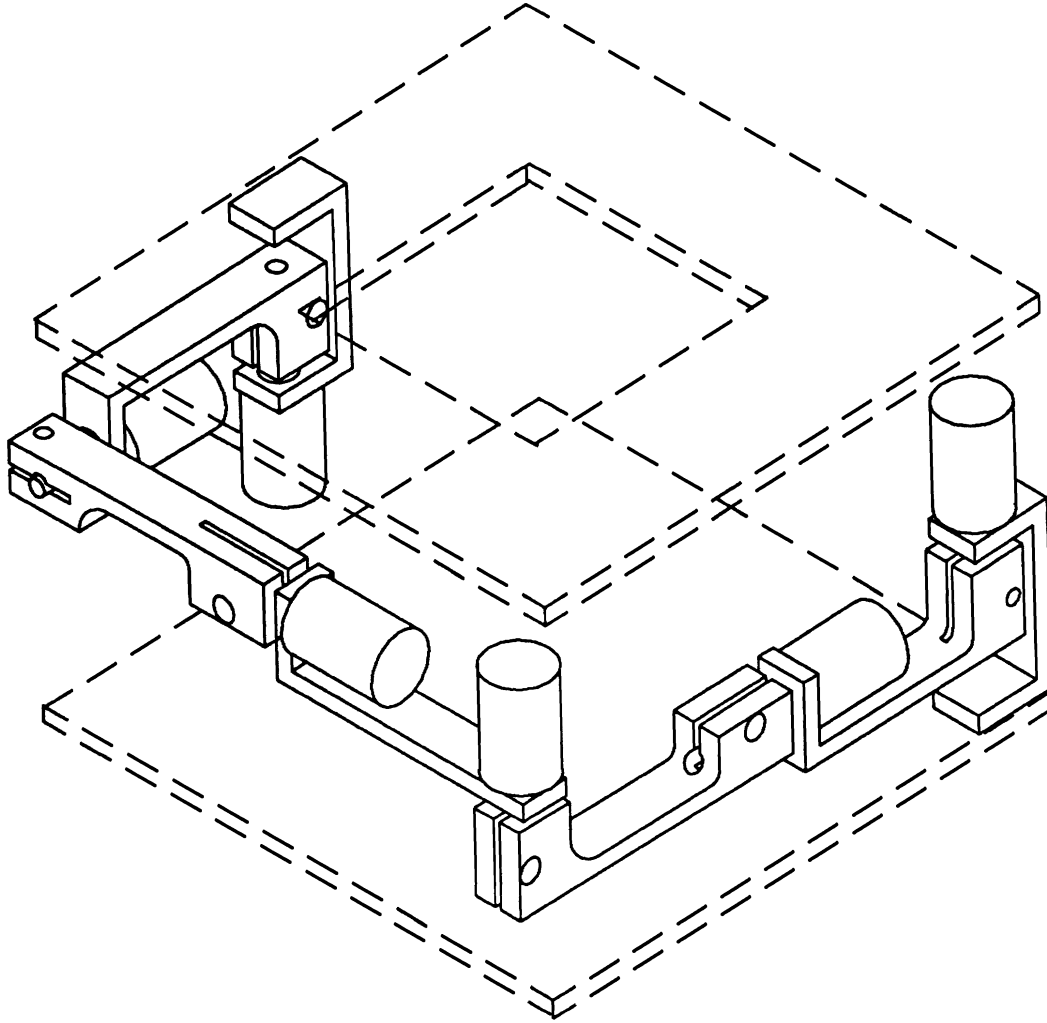

Figure 5: Serial Linkage Chain

3 Linkage Kinematics

The sensing mechanism is composed of a serial linkage chain with potentiometers at each joint. Figure 5 shows the serial linkage.

Using forward kinematics, the transformation between the robot wrist and the end of the tool can be calculated. The kinematic skeleton of the wrist is shown in figure 6.

The D-H parameters for the sensing mechanism, shown in figures 7 and 8 are:

joint	a	d	α	θ
	mm	mm	deg.	deg.
1	0	-24.5	-90	θ_1
2	0	95.0	-90	θ_2
3	0	24.5	90	$-90 + \theta_3$
4	0	95.0	90	$-90 + \theta_4$
5	0	47.5	90	$90 + \theta_5$
6	47.5	-24.5	180	$180 + \theta_6$

```

u33 = -s2 * s3 * c4 - c2 * s4;
u34 = -d4 * s2 * c3 + d3 * c2 - d1;

/* v = u * A5 */
v11 = -u11 * s5 + u12 * c5;
v12 = u13;
v13 = u11 * c5 + u12 * s5;
v14 = d5 * u13 + u14;

v21 = -u21 * s5 + u22 * c5;
v22 = u23;
v23 = u21 * c5 + u22 * s5;
v24 = d5 * u23 + u24;

v31 = -u31 * s5 + u32 * c5;
v32 = u33;
v33 = u31 * c5 + u32 * s5;
v34 = d5 * u33 + u34;

/* Wrist transform */
tw.n.x = -v11 * c6 - v12 * s6;
tw.o.x = -v11 * s6 + v12 * c6;
tw.a.x = -v13;
tw.p.x = -a6 * v11 * c6 - a6 * v12 * s6 + d6 * v13 + v14;

tw.n.y = -v21 * c6 - v22 * s6;
tw.o.y = -v21 * s6 + v22 * c6;
tw.a.y = -v23;
tw.p.y = -a6 * v21 * c6 - a6 * v22 * s6 + d6 * v23 + v24;

tw.n.z = -v31 * c6 - v32 * s6;
tw.o.z = -v31 * s6 + v32 * c6;
tw.a.z = -v33;
tw.p.z = -a6 * v31 * c6 - a6 * v32 * s6 + d6 * v33 + v34;

/* Compute roll, pitch, and yaw angles from wrist transform */
noatorpy(&car_diffs[5],&car_diffs[4],&car_diffs[3],&tw);
car_diffs[0] = tw.p.x;
car_diffs[1] = tw.p.y;
car_diffs[2] = tw.p.z - 73.5; /* 73.5 is the thickness of the wrist */
}

/*-----*/

```

6 Wrist Plans

6.1 General

The compliant structure and the sensing linkage are sandwiched between the top and bottom plate. The compliant structure is connected to the bottom plate with four 8-32 x 1/2" countersunk machine screws, and to the top plate by the compliant elements. The sensing linkage is attached to the top and bottom plates by two 8-32 x 1/8" countersunk machine screws. The wrist is connected to the robot via a quick mount mechanism (Lord Corporation, not shown), which bolts into the four 8-32 threaded holes in the bottom plate. A 16-pin connector is also attached to the bottom plate.

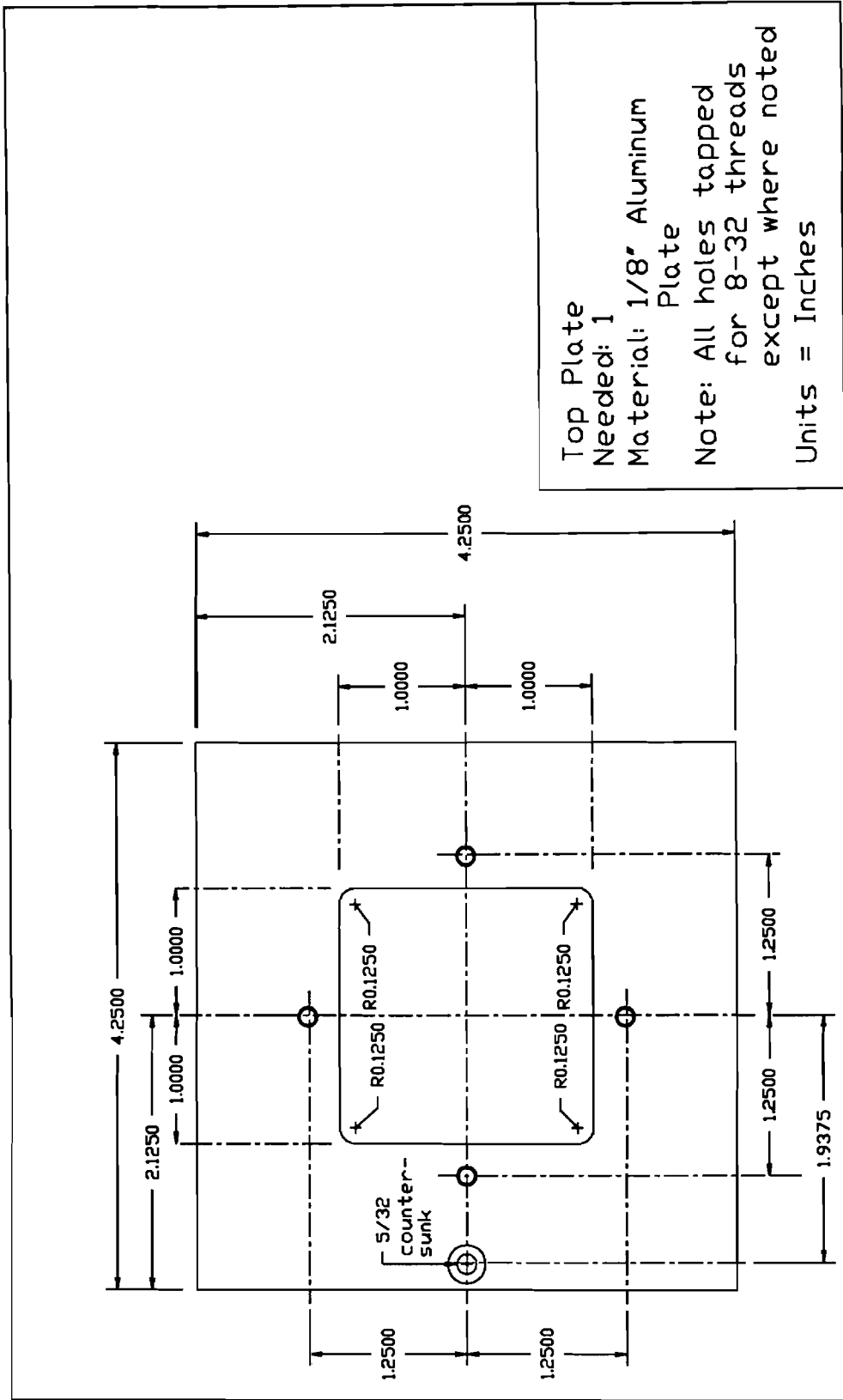

Figure 9: Top Plate

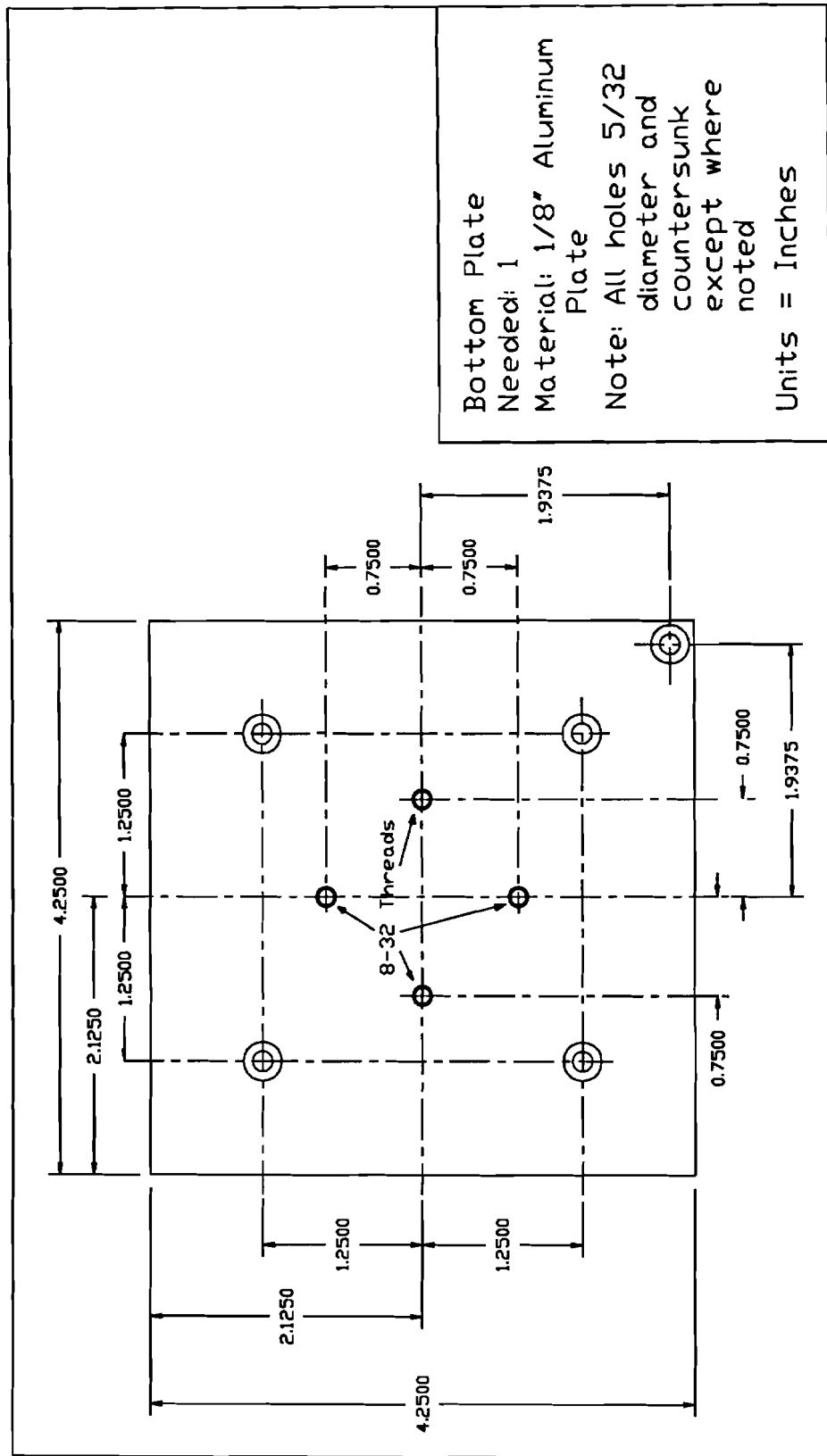

Figure 10: Bottom Plate

6.2 Compliant Structure

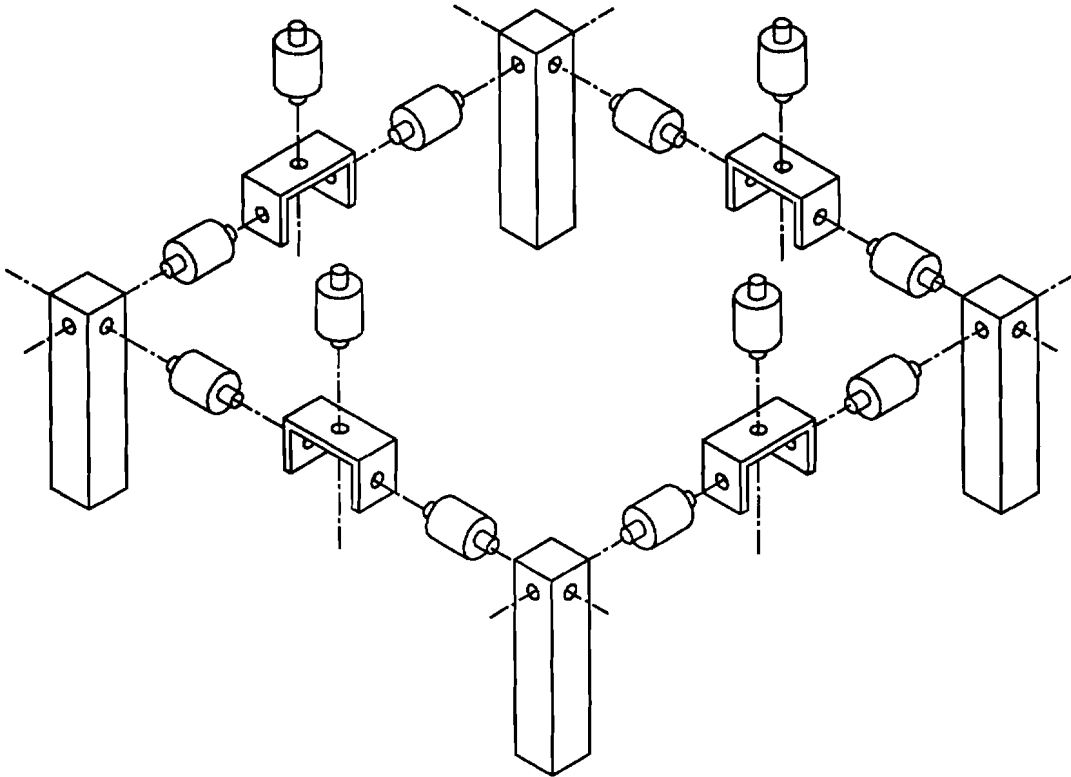

Figure 11: Compliant Structure - Exploded View

The 12 compliant elements are part number 10Z2-302A from Stock Drive Products, New Hyde Park, NY. These elements have 8-32 x 3/8" threaded studs. Four of these must have one stud shortened to 3/16", one each attached to compliant structure piece 2. All elements connected to compliant structure piece 1 are attached with 8-32 hex nuts.

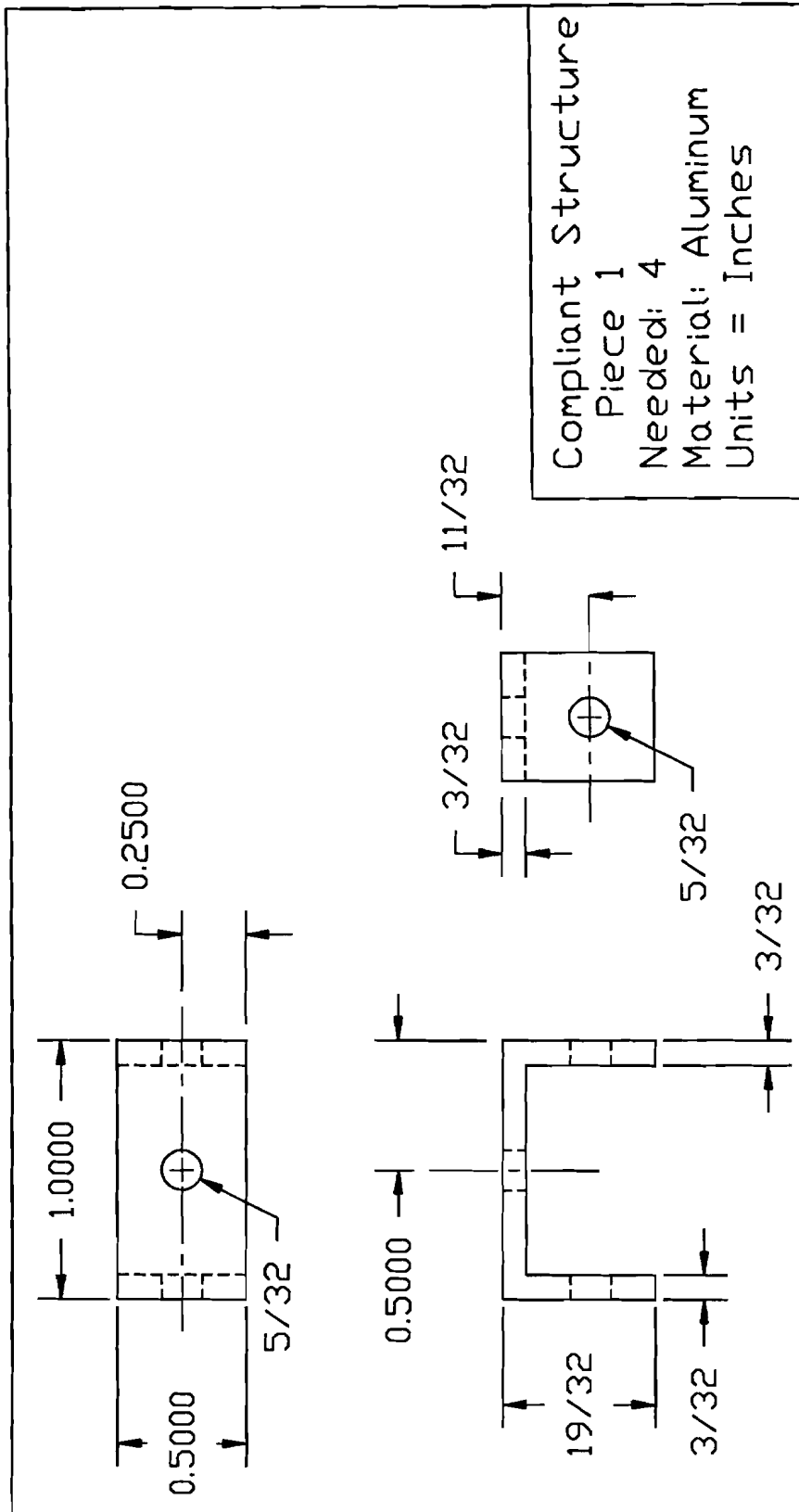
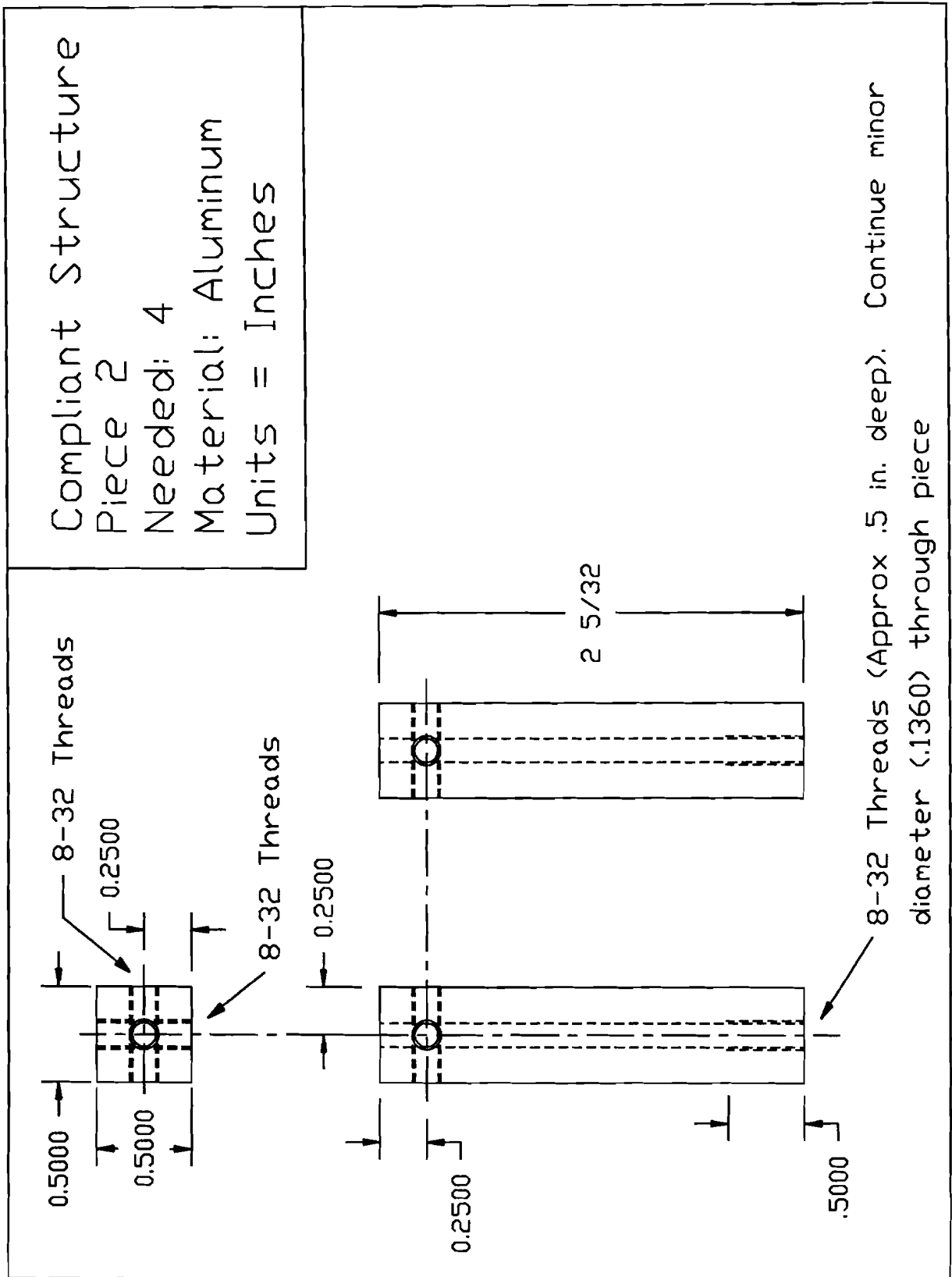

Figure 12: Compliant Structure Piece 1



Compliant Structure
 Piece 2
 Needed: 4
 Material: Aluminum
 Units = Inches

Figure 13: Compliant Structure Piece 2

6.3 Sensing Linkage

Potentiometers used are part number RV6 NAYSD 10 2 A from Clarostat Mfg. Co., Inc., Dover, NH. Potentiometers are attached to linkage pieces with 4-40 x 1/4" machine screws.

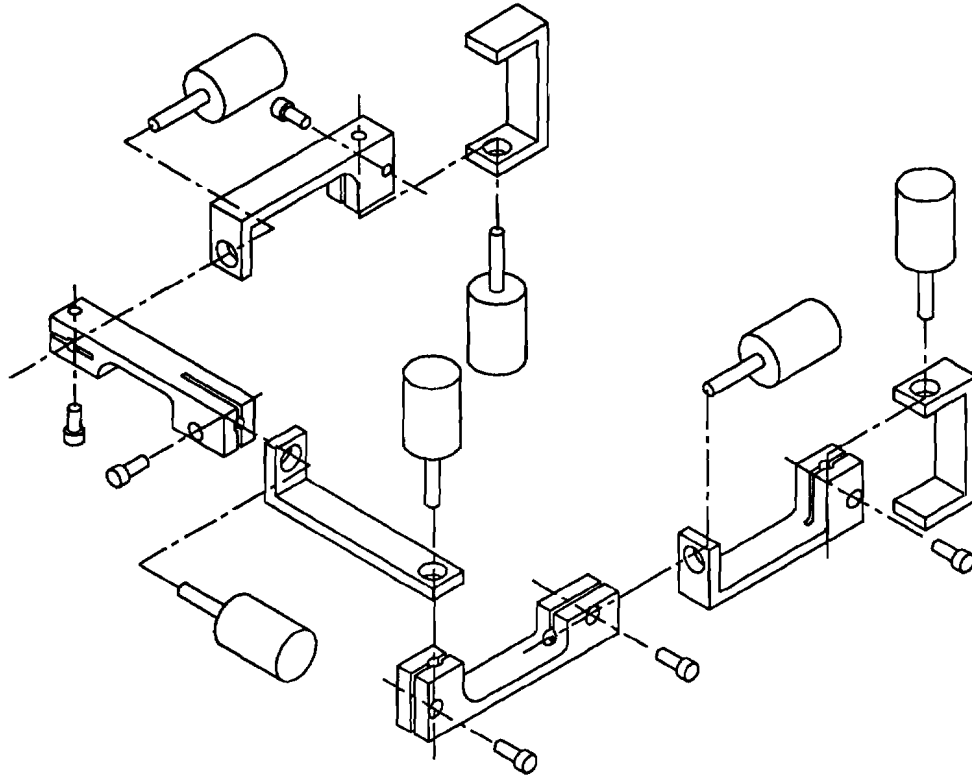

Figure 14: Sensing Linkage - Exploded View

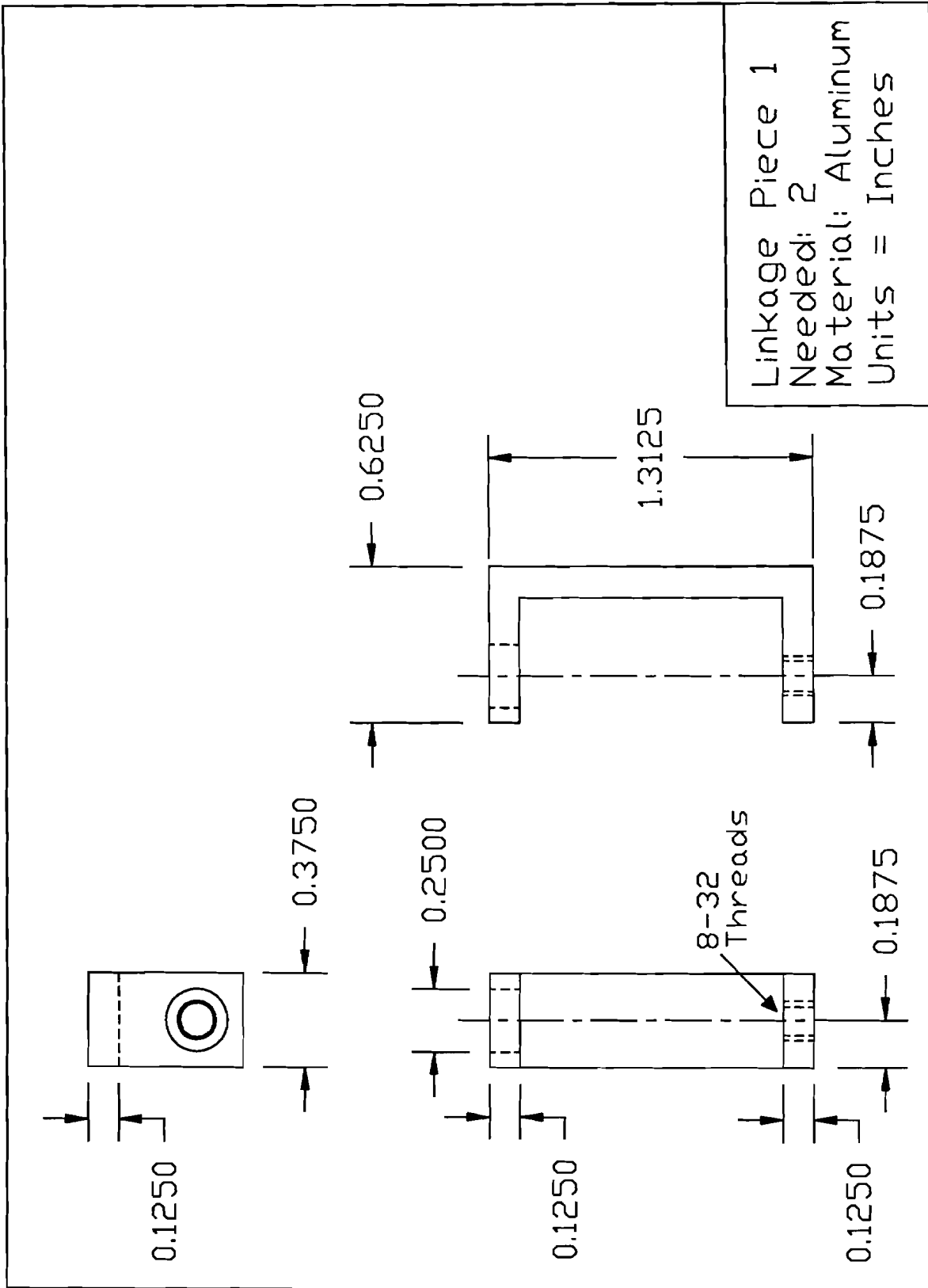

Figure 15: Linkage Piece 1

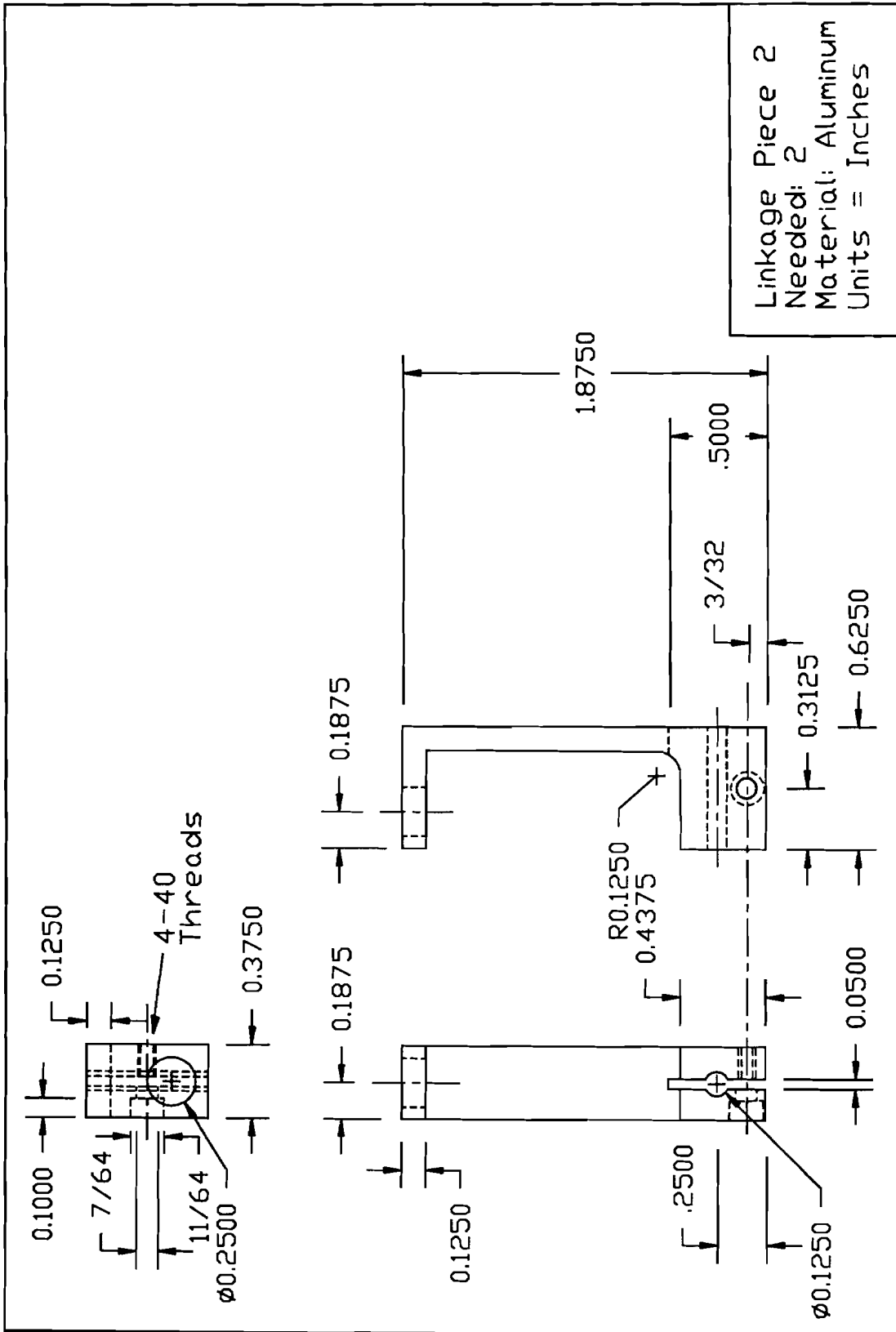

Figure 16: Linkage Piece 2

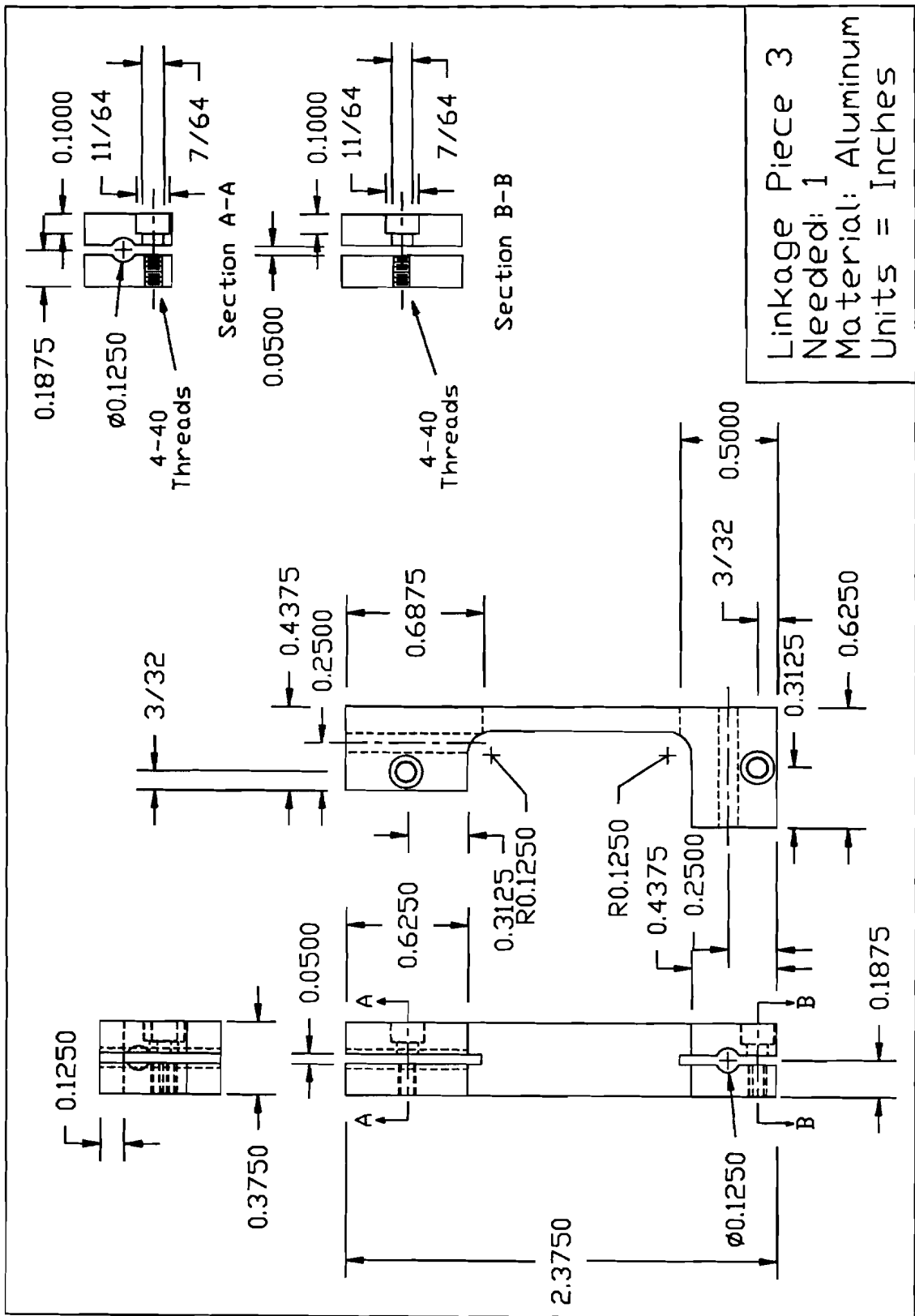
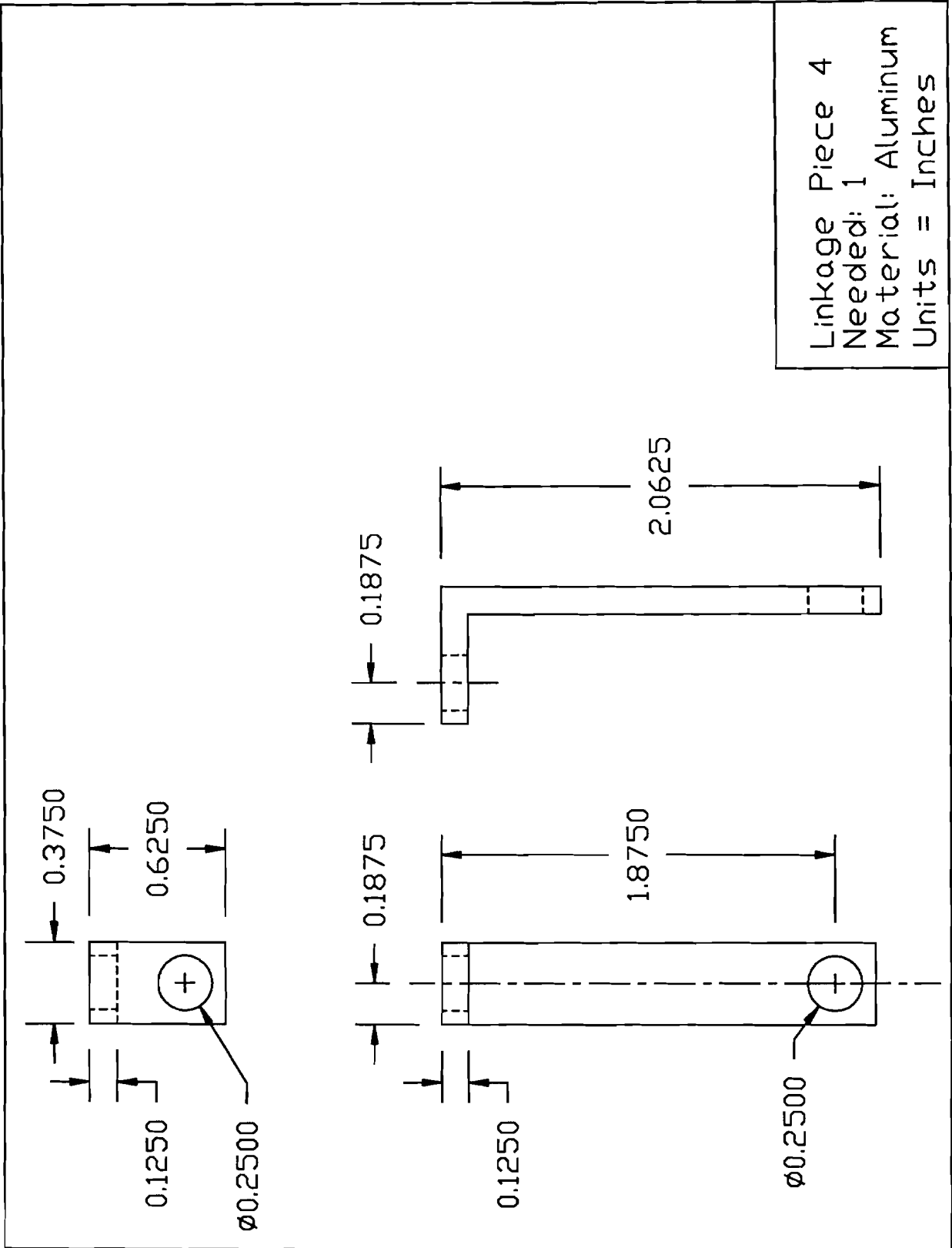

Figure 17: Linkage Piece 3



Linkage Piece 4
 Needed: 1
 Material: Aluminum
 Units = Inches

Figure 18: Linkage Piece 4

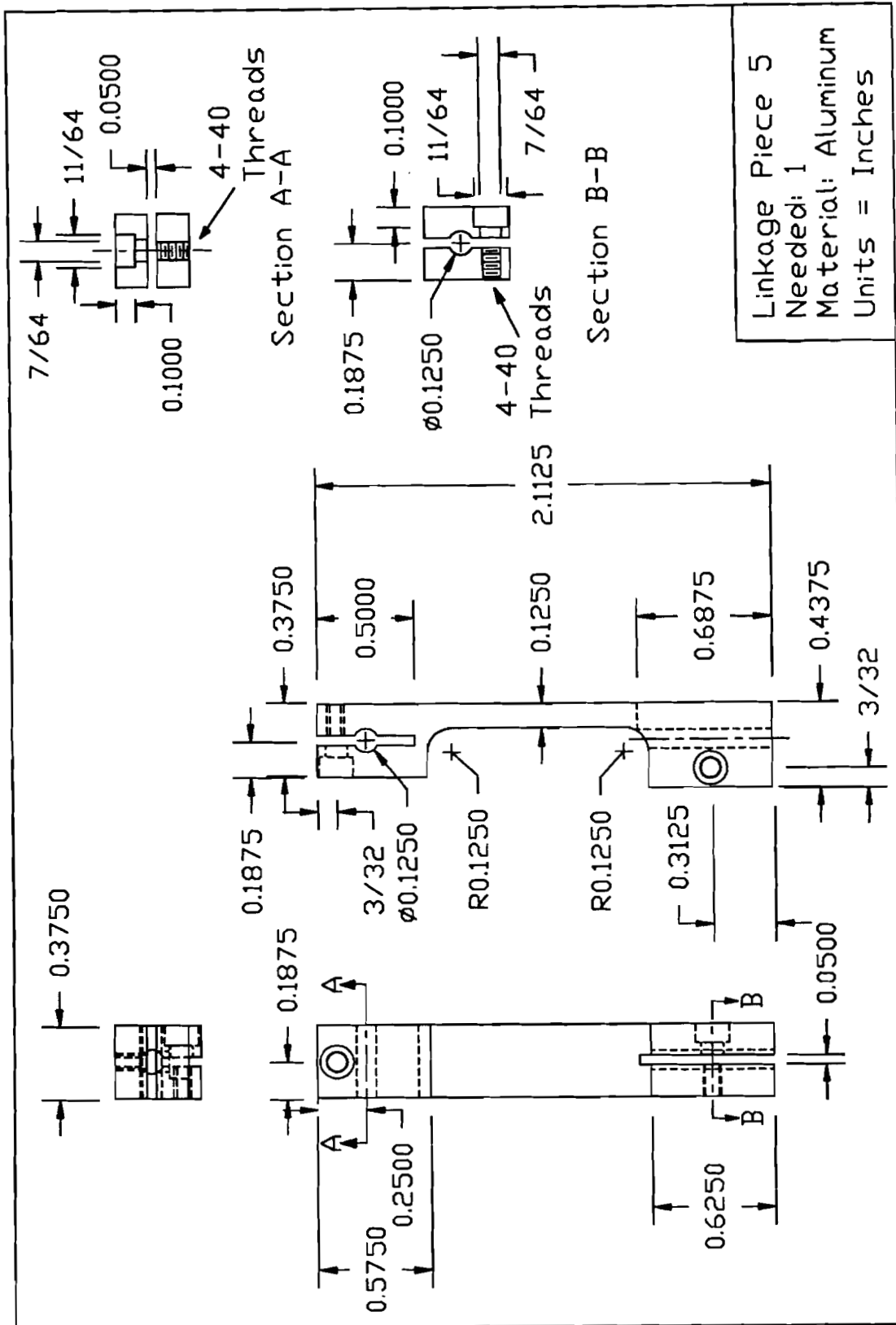

Figure 19: Linkage Piece 5

6.4 Electronics

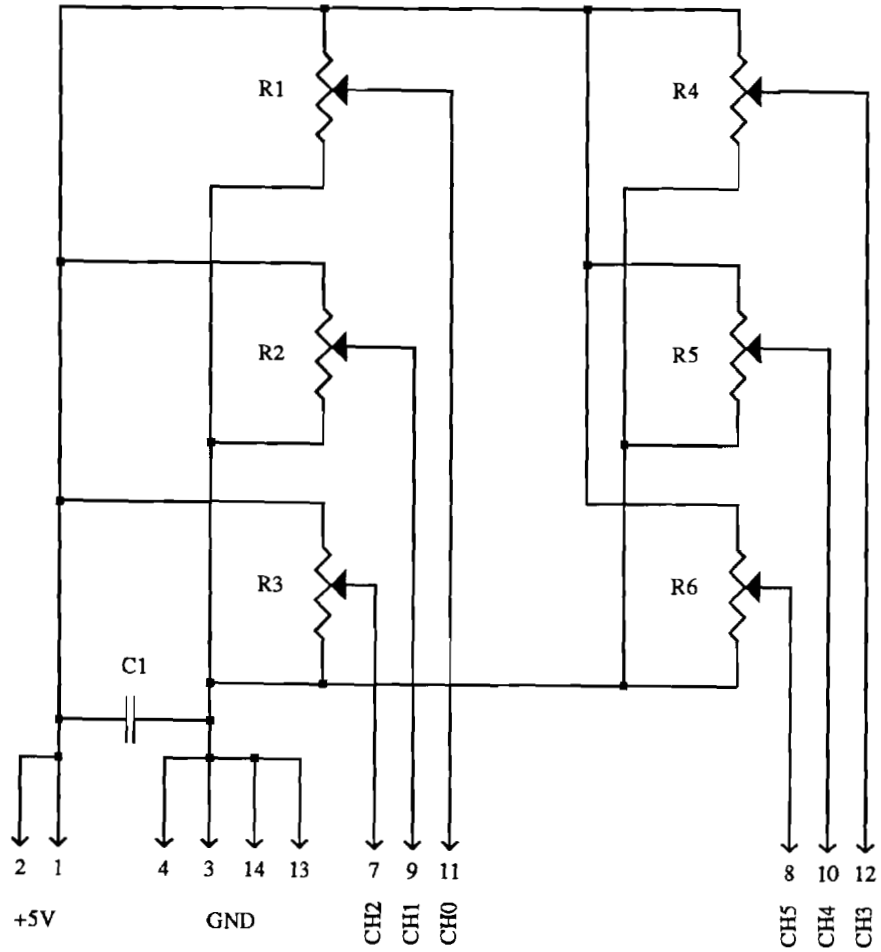

Figure 20: Wrist Electronics

In figure 20, $C1 = .1\mu\text{F}$.

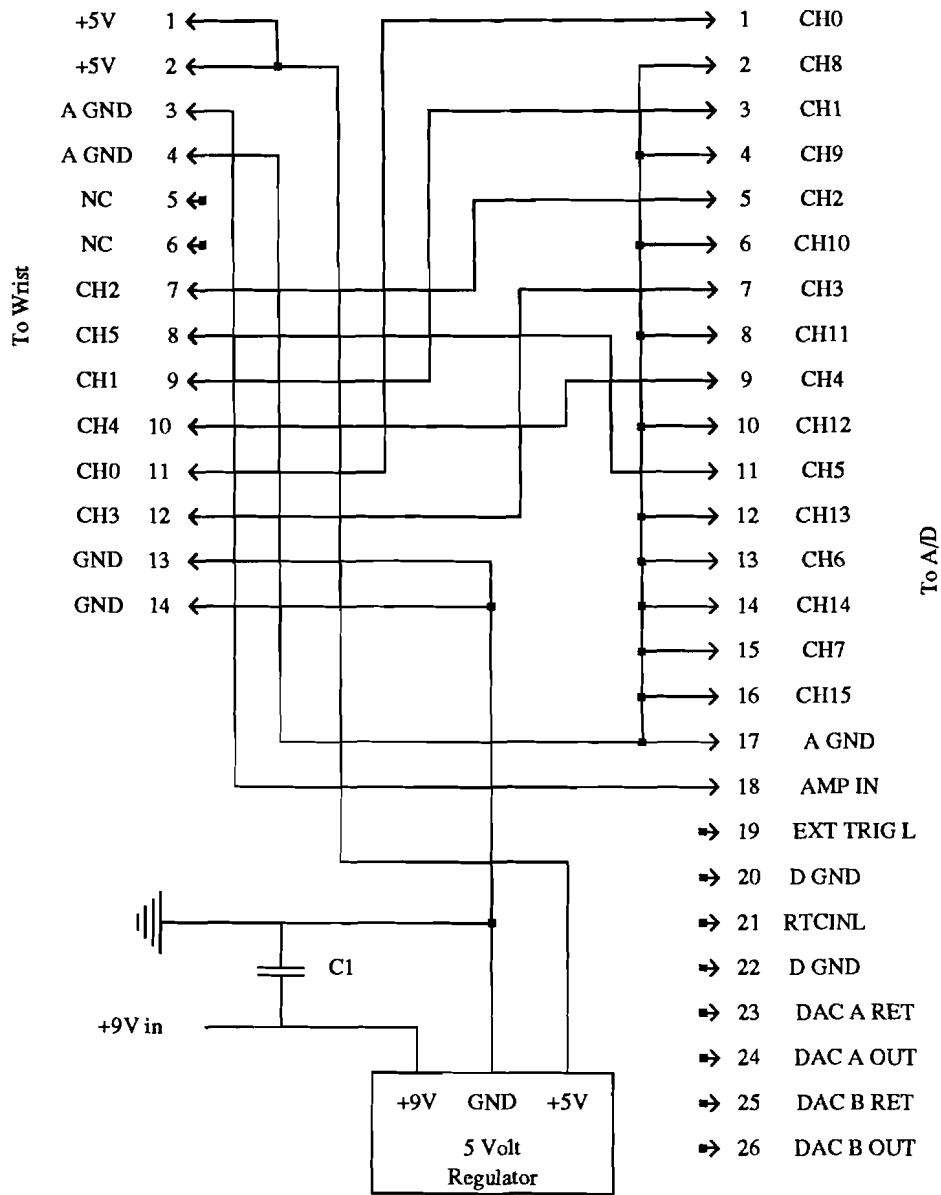

Figure 21: Power and Connections

In figure 21, $C1 = 1.0 \mu\text{F}$.

7 Conclusion and Future Work

The wrist outlined here is currently in use in the GRASP lab. Projects using the wrist include “Teleprogramming: Towards Delay-Invariant Remote Manipulation” [2] and “Robotic Exploration of Surfaces with a Compliant Wrist Sensor” [4]. The wrist has been shown to be a useful force/torque sensor for hybrid position/force control implementations.

Planned work includes design of improved electronics, and shortening the wrist by 1/2”. Future work includes a more accurate analysis of the compliance, a dynamic model of the wrist, and research into potentiometers with better characteristics for the wrist.

References

- [1] *Vibration and Shock Mount Handbook*. Stock Drive Products, New Hyde Park, NY, 1984. Product Catalog 814.
- [2] J. Funda and R. P. Paul. Efficient control of a robotic system for time-delayed environments. To appear in *Proceedings of the Fifth International Conference on Advanced Robotics*, Pisa, Italy, June 1991.
- [3] Randall K. Roberts, R. P. Paul, and Benjamin M. Hillberry. The effect of wrist force sensor stiffness on the control of robot manipulators. In *Proceedings of the IEEE International Conference on Robotics and Automation*, pages 269–274, April 1985.
- [4] P.R. Sinha, Y. Xu, R.K. Bajcsy, and R.P. Paul. Robotic Exploration of Surfaces using a Compliant Wrist Sensor. Under review with the International Journal of Robotics Research.
- [5] Richard Volpe and Pradeep Khosla. Experimental verification of a strategy for impact control. In *Proceedings of the IEEE International Conference on Robotics and Automation*, pages 1854–1860, 1991.
- [6] Yangsheng Xu. *Compliant wrist design and hybrid position/force control of robot manipulators*. PhD thesis, University of Pennsylvania, 1989.