



University of Pennsylvania  
ScholarlyCommons

Departmental Papers (MEAM)

Department of Mechanical Engineering & Applied  
Mechanics

6-12-2007

# Effects of Visual and Proprioceptive Motion Feedback on Human Control of Targeted Movement

Katherine J. Kuchenbecker  
*University of Pennsylvania*, [kuchenbe@seas.upenn.edu](mailto:kuchenbe@seas.upenn.edu)

Netta Gurari  
*University of Pennsylvania*

Allison M. Okamura  
*University of Pennsylvania*

Follow this and additional works at: [http://repository.upenn.edu/meam\\_papers](http://repository.upenn.edu/meam_papers)

 Part of the [Mechanical Engineering Commons](#)

## Recommended Citation

Kuchenbecker, Katherine J.; Gurari, Netta; and Okamura, Allison M., "Effects of Visual and Proprioceptive Motion Feedback on Human Control of Targeted Movement" (2007). *Departmental Papers (MEAM)*. 224.  
[http://repository.upenn.edu/meam\\_papers/224](http://repository.upenn.edu/meam_papers/224)

Suggested Citation: Kuchenbecker, Katherine J. Netta Gurari and Allison M> Okamura. (2007). *Effects of Visual and Proprioceptive Motion Feedback on Human Control of Targeted Movement*. 2007 IEEE 10th International Conference on Rehabilitation Robotics. Noordwijk, The Netherlands. June 12-15, 2007.

©2007 IEEE. Personal use of this material is permitted. However, permission to reprint/republish this material for advertising or promotional purposes or for creating new collective works for resale or redistribution to servers or lists, or to reuse any copyrighted component of this work in other works must be obtained from the IEEE.

---

# Effects of Visual and Proprioceptive Motion Feedback on Human Control of Targeted Movement

## Abstract

This research seeks to ascertain the relative value of visual and proprioceptive motion feedback during force-based control of a non-self entity like a powered prosthesis. Accurately controlling such a device is very difficult when the operator cannot see or feel the movement that results from applied forces. As an analogy to prosthesis use, we tested the relative importance of visual and proprioceptive motion feedback during targeted force-based movement. Thirteen human subjects performed a virtual finger-pointing task in which the virtual finger's velocity was always programmed to be directly proportional to the MCP joint torque applied by the subject's right index finger. During successive repetitions of the pointing task, the system conveyed the virtual finger's motion to the user through four combinations of graphical display (vision) and finger movement (proprioception). Success rate, speed, and qualitative ease of use were recorded, and visual motion feedback was found to increase all three performance measures. Proprioceptive motion feedback significantly improved success rate and ease of use, but it yielded slower motions. The results indicate that proprioceptive motion feedback improves human control of targeted movement in both sighted and unsighted conditions, supporting the pursuit of artificial proprioception for prosthetics and underscoring the importance of motion feedback for other force-controlled human-machine systems, such as interactive virtual environments and teleoperators.

## Disciplines

Engineering | Mechanical Engineering

## Comments

Suggested Citation: Kuchenbecker, Katherine J. Netta Gurari and Allison M> Okamura. (2007). *Effects of Visual and Proprioceptive Motion Feedback on Human Control of Targeted Movement*. 2007 IEEE 10th International Conference on Rehabilitation Robotics. Noordwijk, The Netherlands. June 12-15, 2007.

©2007 IEEE. Personal use of this material is permitted. However, permission to reprint/republish this material for advertising or promotional purposes or for creating new collective works for resale or redistribution to servers or lists, or to reuse any copyrighted component of this work in other works must be obtained from the IEEE.

# Effects of Visual and Proprioceptive Motion Feedback on Human Control of Targeted Movement

Katherine J. Kuchenbecker, Netta Gurari, and Allison M. Okamura

**Abstract**— This research seeks to ascertain the relative value of visual and proprioceptive motion feedback during force-based control of a non-self entity like a powered prosthesis. Accurately controlling such a device is very difficult when the operator cannot see or feel the movement that results from applied forces. As an analogy to prosthesis use, we tested the relative importance of visual and proprioceptive motion feedback during targeted force-based movement. Thirteen human subjects performed a virtual finger-pointing task in which the virtual finger’s velocity was always programmed to be directly proportional to the MCP joint torque applied by the subject’s right index finger. During successive repetitions of the pointing task, the system conveyed the virtual finger’s motion to the user through four combinations of graphical display (vision) and finger movement (proprioception). Success rate, speed, and qualitative ease of use were recorded, and visual motion feedback was found to increase all three performance measures. Proprioceptive motion feedback significantly improved success rate and ease of use, but it yielded slower motions. The results indicate that proprioceptive motion feedback improves human control of targeted movement in both sighted and unsighted conditions, supporting the pursuit of artificial proprioception for prosthetics and underscoring the importance of motion feedback for other force-controlled human-machine systems, such as interactive virtual environments and teleoperators.

## I. INTRODUCTION

Unimpaired humans can adeptly control the motion of their upper limbs, easily accomplishing the activities of daily living and over time mastering manual skills like touch typing, sign language, and surgical suturing. Naturally, upper-limb amputees and individuals with congenital upper-limb deficiencies want to be able to interact with their surroundings with this same level of ease [1]. Researchers in the field of prosthetics now seek to develop devices and systems that function as well as an intact human arm and hand, seamlessly responding to the wearer’s motor commands and feeding back authentic haptic sensations. Progress toward this ambitious goal will require a thorough understanding of the human capabilities for perception and movement control.

As overviewed in Section II-A, an intact human upper limb provides a plethora of synergistic haptic feedback to the central nervous system, complemented by visual perception of the arm, hand, and environment. In contrast, what signals are available to the wearer of a typical modern prosthesis? Section II-C discusses the state of the art in this field, and Fig. 1 illustrates the information flow pattern that we observe for the use of a powered myoelectric prosthesis.

The authors are with the Mechanical Engineering Department, Johns Hopkins University, Baltimore, Maryland 21218, USA. Email: kuchenbecker@seas.upenn.edu

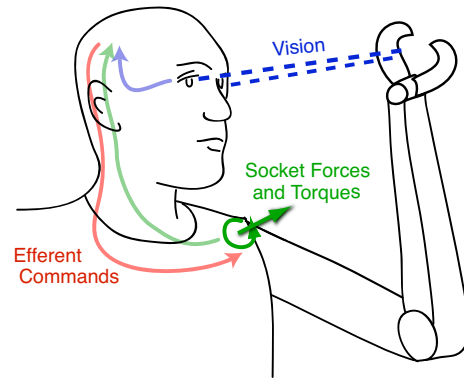

Fig. 1. Prosthesis signal flow. The user of a typical powered prosthesis knows his or her efferent commands, feels socket forces and torques, and can see the prosthesis when it is visible; however, the user cannot feel the limb’s movement because conventional prostheses do not provide a substitute for motion proprioception.

First, the wearer is aware of the efferent motor commands he or she is sending to the prosthetic device. These signals correspond to muscle activation and stem from a higher-level cognitive goal, such as wanting to press an elevator call button or pick up a cup of coffee. The electrical and mechanical design of the arm and the properties of its environment determine the means by which these efferent signals generate prosthetic hand movement to accomplish the task. Second, the user can visually attend to the prosthesis if it is in his or her field of view. Stereoscopic vision allows the wearer to discern the current configuration of the prosthesis and its spatial relationship to objects in the environment. Third, socket contact with the residual limb provides the wearer with an indication of the forces and torques acting on the device, which are generally caused by gravity, environmental contact, and system actuators. With practice, prosthesis users may also learn to gather information about their device’s behavior from the sounds, vibrations, and air currents that it creates, but we believe these feedback modalities are less consistent and less important than efferent commands, vision, and socket forces and torques.

When compared to an intact arm, a typical prosthetic upper limb has three main sensory shortcomings: a complete lack of proprioception (the haptic sense of the positions and velocities of body segments), a near-complete lack of exteroception (the haptic senses of contact force, shape, texture, and temperature), and a complete lack of nociception (the physiological awareness of damage to skin, joints, structural members, and actuators). For comparison, individuals who lose proprioception and exteroception through disease [2]

and individuals with a congenital lack of nociception [3] experience extreme difficulty in their daily lives. All three of these sensory deficits will need to be confronted by prosthetics researchers in the coming years, and we are dedicating our current efforts to understanding the implications of the deficiency in proprioception. We hypothesize that providing the wearer with artificial proprioceptive feedback will make a prosthesis easier to control, especially when visual feedback is not available.

This research seeks to test our hypothesis by ascertaining the relative value of visual and proprioceptive motion feedback for individuals attempting to control the motion of a virtual finger. After Section II's discussion of human movement control and upper-limb prostheses, Section III describes the design of our human subject experiment, including the chosen targeted motion task, our experimental apparatus, our methods for controlling the availability of visual and proprioceptive motion feedback, and our testing procedures. The results of this study, which include qualitative ease-of-use ratings, movement accuracy, and movement speed, are presented in Section IV and discussed in Section V. As summarized in Section VI, our current findings indicate that proprioceptive motion feedback both quantitatively and qualitatively improves human control of targeted movement in both sighted and unsighted conditions; further research will help unravel the mechanisms behind this improvement, as will the development of new methods for providing artificial proprioception in prosthetics.

## II. BACKGROUND

### A. Proprioception

This study focuses on the impact of proprioception on motion control. As there is no universal definition for the term proprioception in the literature, we choose to follow Björklund's: "the perception of positions and movements of the body segments in relation to each other without the aid of vision, touch, or the organs of equilibrium" [4]. The proprioceptive sense is derived from a combination of afferent channels, including muscle spindle fibers, Golgi tendon organs, joint angle sensors, and skin stretch (perceived through cutaneous mechanoreceptors) [5], [6]. Additionally, an efferent signal can create an arm-motion percept even when the human arm is held stationary [7]. The index finger metacarpophalangeal (MCP) joint used in the present study has a proprioceptive just noticeable difference (JND) of 3.99 mm of fingertip movement, which corresponds to approximately  $2.3^\circ$  of joint rotation [8].

Designing experiments that deprive human subjects of proprioceptive feedback is difficult because this feedback channel cannot be voluntarily disabled, unlike vision. Most commonly employed methods for blocking proprioception, such as anesthesia [9] and ischemia [10], are invasive and slow to take effect. Moreover, these methods additionally block tactile sensations. Vibrations have also been employed to confound proprioceptive afferents [11]. This method is successful at distorting a person's perception of his/her limb's

position in space, but it does not block the proprioception sense.

### B. Motion and Force Control

People afflicted with acute sensory neuropathy or severe large-fiber sensory neuropathy have varying levels of impairment to their proprioceptive feedback, the former experiencing a nearly complete loss of proprioception throughout the entire body and the latter only in isolated locations. Even in the absence of proprioceptive feedback, these two populations have shown that motion control is still possible with visual feedback of limb configuration [12], [13].

In one well-documented case, a patient afflicted with acute sensory neuropathy permanently lost proprioceptive feedback along with most cutaneous sensations (with the exception of pain and temperature) from his collar line down [12]. Eventually he relearned how to control his body's movements by relying mainly on visual feedback. Similarly, patients with severe large-fiber sensory neuropathy affecting both the trunk and the arms were able to use vision for motion control [13]. These deafferented patients were compared with neurologically normal subjects in a multi-joint reaching task under vision and/or proprioception conditions. The patients lacking proprioceptive feedback had more errors when following a trajectory than neurologically normal adults, implying that proprioceptive feedback improves movement control both with and without sight. Summarizing, sight can enable motion control when vision is not possible, but even with sight, proprioceptive feedback improves motion control. These previous results did not measure the effect of proprioception on ease of task performance or allow for within-subjects analysis, as was done in the current study.

When neither visual nor proprioceptive feedback are available, motion control is still possible if the initial arm configuration is known. Distorting proprioceptive afferents via muscle vibrations, Larish et al. found that an accurate proprioceptive knowledge of limb initial conditions is necessary to position a limb when vision is occluded [11]. Ghez et al. showed that for partially deafferented patients, when vision was permitted only briefly before the trial began (pre-vision), the patients' success at following the trajectory substantially increased [13]. In most cases, pre-vision was as effective at reducing error as when visual feedback was provided throughout the entire trial. Even so, the patients' arms tended to drift upon movement termination in both sighted and unsighted conditions. Thus, proprioception enhances human motor control both with and without sight during stabilization tasks.

Our experimental setup invokes both motion and force control of the right index finger about the MCP joint. Tan et al. showed that the average maximum controllable finger-force output is between 17.6 N and 42.6 N [14]. For a target force of 22.2 N, the average human force control resolution in the range of 0.28 N to 0.30 N. Human ability to control force output is better at low levels; Wu et al. found an absolute control precision (standard deviation) of approximately 0.03 N at isometric target forces below

3 N [15]. These authors also noted that human force control is significantly degraded when the pressed object moves away from the finger at velocities greater than 2 cm/s due to the biomechanical coupling between finger and object.

### C. Prosthetics

Upper-limb prostheses seek to seamlessly replace the user's missing appendage, but current devices cannot yet match the functionality of an intact human arm and hand. During a 1996 survey of upper-arm prosthesis users in the United States, two of the most common requests were for a device that "required less visual attention to perform functions" and could perform "coordinated motions of two joints at the same time" [1]. To meet this demand, the field has seen a rapid growth in the development of multi-articulating, highly-sensorized prosthetic devices. Modern systems are being developed to control complex motions using electrical signals recorded from the user's residual arm muscles [16] or by directly tapping into motor neurons [17] to determine desired force commands for the prosthetic arm.

Most current devices are being designed with built-in position and force sensors, allowing for artificial proprioceptive and exteroceptive systems, e.g. [18]. To decrease the need for visual control, researchers are experimenting with different methods of providing sensory feedback to the user, primarily through the use of small actuators placed in contact with the user's skin. Focusing on the feedback of grip forces, Pylatiuk et al. investigated the use of vibrotactile actuators [19], Patterson and Katz tested a pressure cuff and a vibratory actuator [20], and Meek et al. investigated a combination of force and vibratory feedback [21]. These various methods have shown mixed results, though control of grasp force was often complicated by the subject's ability to learn the dynamic mapping of the prosthesis itself.

Regarding proprioceptive motion feedback, sensory substitution has been shown to be a potentially viable method for communicating prosthesis joint angle, typically implemented via small electrotactile or vibrotactile actuators that stimulate the user's skin according to a pre-determined code [22]. We are aware of only one instance of neurally-integrated artificial proprioception: Dhillon and Horch developed a method to feed back the elbow joint position of a prosthetic arm via electrodes implanted into individual fascicles of the peripheral nerve stumps [17]. This system enabled long-term amputees to sense joint positions applied to the artificial limb without visual feedback, but closed-loop movement control results have not yet been reported.

## III. EXPERIMENT DESIGN

Researchers in the field of prosthetics need to understand the role of proprioceptive feedback during human movement control in order to design effective upper-limb prostheses. Methods for artificially stimulating the wearer's proprioceptive sense with an indication of the prosthesis' configuration should be avidly pursued if such feedback would improve the individual's ability to control its movement. We sought



Fig. 2. Experiment setup. Subjects controlled the virtual finger's movement through a custom finger apparatus (behind curtain) and a desktop computer.

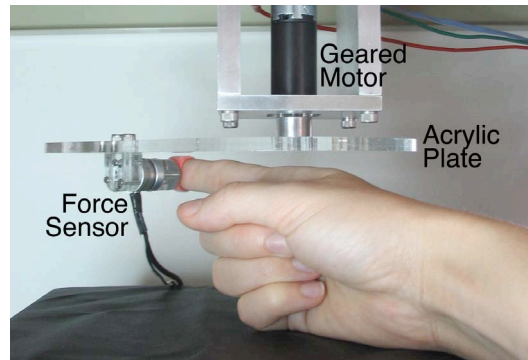

Fig. 3. Custom finger apparatus. The system measures the force applied by the subject's fingertip to determine the movement of the virtual finger. The shaft of the geared motor aligns with the subject's MCP joint to give the apparatus control over index finger angle.

to design a human subject experiment that would elucidate this topic in a simple, noninvasive manner.

We opted to study one-degree-of-freedom movement and chose the MCP joint of the right index finger to represent general upper-limb motion. As pictured in Fig. 2, unimpaired subjects were asked to control the pointing movement of a virtual finger through interaction with a custom apparatus and desktop computer, creating a simple analogy to upper-limb prosthesis control. During the experiment, the apparatus was concealed from sight by a curtain, and the subject wore noise-canceling headphones playing pink noise to mask auditory cues and distractions. As the subject attempted to move the virtual finger to targets displayed on the monitor, the system selectively provided visual and proprioceptive motion feedback in various combinations, and the subject's resulting performance and subjective ease-of-use rating were recorded. The sections below describe the recruited subject pool, experimental hardware, virtual finger dynamics, visual and proprioceptive motion feedback methods, and experimental procedures.

### A. Subjects

This study included five male and eight female subjects, all of whom were right-handed engineers or scientists. The mean age of the subjects was 24.6 years, with a minimum of 18 and a maximum of 34. Subjects reported their experience with haptic interfaces and virtual environments as *none*, *limited*, *moderate*, or *extensive*; there were 1, 4, 3, and 5 subjects in these categories, respectively. The mean length of the subjects' right index fingers ( $l_f$ , measured from the MCP joint to the center of the distal phalanx) was 7.28 cm with a minimum of 6.3 cm and a maximum of 8.2 cm. No subject reported a neurological illness or physical injury that would impair hand movement or sensation, nor did any subjects declare uncorrected close-range visual impairment. Experimental procedures were approved by the Johns Hopkins University Homewood Institutional Review Board, and all subjects gave informed consent. The experiment was performed in one session lasting approximately forty-five minutes.

### B. Apparatus

The subject controls the movement of the virtual finger through the custom one-degree-of-freedom haptic interface pictured in Fig. 3. This apparatus is composed of an aluminum base structure, a 128:1 geared Maxon A-max 22 DC motor with attached encoder, a clear acrylic plate affixed to the motor shaft, and an ATI Nano17 force sensor. During each experimental set, the user rests his or her right hand on a support below the apparatus so that the index-finger MCP joint is aligned with the motor shaft. The experimenter adjusts the radial position of the force sensor for each user to the appropriate finger length,  $l_f$ . The fingertip is attached to the force sensor through a Velcro loop and a 1 cm thick acrylic block, which helps minimize thermal drift of the force measurement.

The computer samples the force sensor and the motor's encoder at a nominal rate of 1000 Hz. The resolution of the analog-to-digital force measurement is 0.003125 N, and the resolution of the encoder is  $0.00704^\circ$  at the finger. The gear head allows about  $1.6^\circ$  of unsensed backlash in finger movement; as discussed below, each trial of the chosen task requires finger torques in only one direction, so the backlash had minimal impact on system operation. During each execution of the servo loop, the controller uses the measured finger force,  $F_f$ , and the measured finger angle,  $\theta_f$ , to help determine the appropriate current command to output to the linear amplifier that is attached to the motor. The full system controller is illustrated in Fig. 5, and its elements are described below.

When the motor is controlled via closed-loop position feedback to track a desired trajectory, the torque-amplifying gear head makes the system almost impossible for the subject to move. The apparatus thus behaves like an admittance-type (non-backdrivable) haptic interface, in that it measures user force and dictates the user's motion via a programmable dynamic relationship. Admittance-type interfaces are often developed and studied in the field of haptics, e.g. [23],

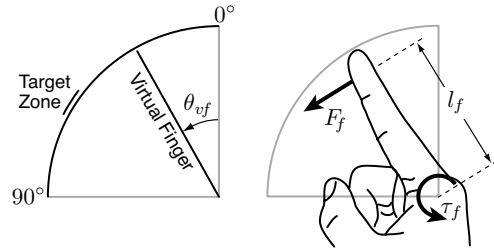

Fig. 4. Virtual and real fingers. The subject applies finger torque ( $\tau_f$ ) to move the virtual finger's position ( $\theta_{vf}$ ) inside the target zone.

[24]; such a device was constructed for this human subject experiment to mimic the experience of interacting with a powered myoelectric prosthesis.

When controlling the virtual finger through the apparatus, as pictured in Fig. 2, the user is aware of the efferent commands sent to his or her finger muscles, can feel the applied fingertip forces (a rough analogy to socket forces and torques), and can observe the virtual finger's movement on the computer screen (when such feedback is provided). To withhold proprioceptive motion feedback, the system keeps the subject's finger stationary, regardless of the movement of the virtual finger, so that the movement that results from the applied forces cannot be felt. This condition corresponds to isometric operation and was designed to be analogous to powered prosthesis control without proprioceptive feedback. In contrast, the apparatus provides proprioceptive motion feedback by moving the subject's finger to track the position of the virtual finger, so that its movement is directly available via proprioception. This condition corresponds to isotonic operation and is analogous to controlling a prosthesis that provides perfect artificial proprioception.

### C. Virtual finger dynamics

Subjects used the apparatus to control the motion of a torque-based virtual finger in a simple virtual environment. As depicted in Fig. 4, the virtual finger has one rotational degree of freedom,  $0^\circ \leq \theta_{vf} \leq 90^\circ$ , analogous to the rotation of the right index finger about the MCP joint. Subjects controlled the motion of the virtual finger by gently pushing and pulling on the apparatus with the distal phalanx of their right index finger. As diagrammed in Fig. 5, the apparatus measures the finger force  $F_f$ , and the system computes the applied finger torque  $\tau_f$  as

$$\tau_f = l_f F_f, \quad (1)$$

using the subject's measured index finger length  $l_f$ . The virtual finger's angular velocity  $\omega_{vf}$  is programmed to be directly proportional to the applied finger torque via

$$\omega_{vf} = \frac{\tau_f}{b_{vf}}, \quad (2)$$

where  $b_{vf} = 0.005 \frac{\text{Nm}}{\text{deg/s}}$  and represents the virtual finger's viscous response.

This simple dynamic relationship, which mimics a rotational damper, was chosen because it allows the user to stop the virtual finger at any position by applying zero finger torque. In practice, a  $\pm 0.005$  Nm dead band was included

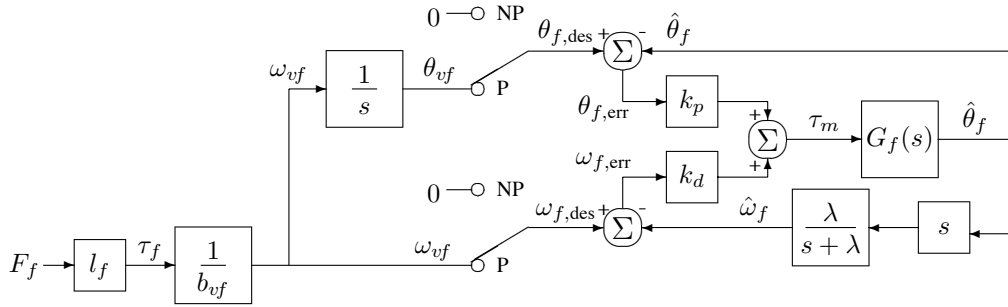

Fig. 5. Controller block diagram. The position and velocity of the virtual finger ( $\theta_{vf}$  and  $\omega_{vf}$ ) are computed from the finger force ( $F_f$ ) applied by the user. Under proprioceptive motion feedback (P condition), the system uses closed-loop position and velocity control to make the subject's finger track the virtual finger's movement. Without proprioceptive motion feedback (NP condition), the controller seeks to hold the finger motionless at  $\theta_f = 0^\circ$ .  $G_f(s)$  stands for the movement dynamics of the user's finger and the piece of the apparatus to which it is attached.

in the finger-torque computation of (1) to make it easier to bring the virtual finger to absolute rest; this torque dead band corresponds to a finger-length-dependent force dead band of approximately  $\pm 0.07$  N, which is on the same order of magnitude as the precision of human force control [15].

#### D. Motion feedback methods

This study tested the effects of two types of sensory feedback on the user's ability to control the movement of the virtual finger: visual motion feedback (seeing it move via one's eyes) and proprioceptive motion feedback (feeling it move via one's finger). These two experimental factors each have two levels, delineating the presence or absence of the indicated feedback modality: Visual (V) & No Visual (NV), and Proprioceptive (P) & No Proprioceptive (NP).

1) *Visual motion feedback*: Visual motion feedback was displayed via the computer monitor as a pivoting line segment that continuously tracked the virtual finger's angle. The graphical output was programmed to update at 33 Hz, and there was no noticeable visual latency in the display. For NV conditions, the line segment was not drawn on the monitor during the active movement portion of each trial, but it was always shown between trials to ensure subject comprehension of the next movement's initial conditions (pre-vision). The monitor always showed the  $90^\circ$  arc and the current target zone.

2) *Proprioceptive motion feedback*: As diagrammed in Fig. 5, proprioceptive motion feedback was provided via the apparatus. The motor was used to move the subject's index finger to continuously track a desired trajectory; during P conditions this trajectory was the movement of the virtual finger, and during NP conditions it was motionless at  $0^\circ$ . The desired finger state was determined by the computer at a nominal rate of 1000 Hz. At each execution of the servo loop, the actual time elapsed was measured by querying the computer's processor clock. The virtual finger's instantaneous velocity  $\omega_{vf}$  was calculated from the force sensor reading via (1) and (2), and Euler integration was used to determine the virtual finger's new position via

$$\theta_{vf,k} = \theta_{vf,k-1} + \omega_{vf,k}(t_k - t_{k-1}), \quad (3)$$

where  $k$  is the index of the current execution cycle and  $t$  is the elapsed time in seconds. The controller's desired finger

position and velocity were set according to the present level of proprioceptive motion feedback, as follows:

$$\theta_{f,des} = \begin{cases} 0^\circ & \text{if NP} \\ \theta_{vf} & \text{if P} \end{cases} \quad (4)$$

$$\omega_{f,des} = \begin{cases} 0 \text{ deg/s} & \text{if NP} \\ \omega_{vf} & \text{if P} \end{cases} \quad (5)$$

A low-level proportional-derivative controller was used to make the finger follow its desired trajectory. The subject's finger position,  $\theta_f$ , was estimated every servo cycle by sampling the motor's encoder, and its velocity,  $\omega_f$ , was estimated by backward differencing and application of a first-order low-pass filter with a cut-off frequency  $\lambda$  of 50 Hz. The variables  $\hat{\theta}_f$  and  $\hat{\omega}_f$  signify the controller's estimates for these two variables, as they differ from the true values due to encoder quantization and gear head backlash. The low-level controller then computed the torque to be applied to the finger by the geared motor as

$$\tau_m = k_p(\theta_{f,des} - \hat{\theta}_f) + k_d(\omega_{f,des} - \hat{\omega}_f). \quad (6)$$

The proportional and derivative feedback gains were  $k_p = 0.7744 \frac{\text{Nm}}{\text{deg}}$  and  $k_d = 0.031 \frac{\text{Nm}}{\text{deg/s}}$ . The motor current command was computed from the torque output  $\tau_m$  via the motor's torque constant, and the appropriate voltage was applied to the input of the apparatus' linear current amplifier.

To evaluate the motor controller's performance, we examined the finger positioning errors that occurred during the human subject experiment. The mean of the maximum per-trial error in finger angle ( $|\theta_{f,des} - \hat{\theta}_f|$ ) was  $0.063^\circ$  during NP trials and  $0.110^\circ$  during P trials. Over all subjects and trials, the largest error that ever occurred was  $0.465^\circ$  for NP and  $0.380^\circ$  for P. These tracking errors are very small relative to the proprioceptive angle resolution of the human MCP joint. Therefore the NP level of proprioceptive motion feedback can be viewed as keeping the finger perfectly stationary, and the P level can be treated as a perfect indication of the virtual finger's movement.

#### E. Targeted movement task

The subject's assigned task was to repeatedly move the virtual finger to designated target zones as quickly and accurately as possible. The current motion feedback condition

was displayed throughout each experimental set via icons on the computer monitor. After placing the tip of the right index finger in the apparatus' loop, the subject began each set of trials by pressing the space bar with his or her left hand. At the start of each trial, a new target zone was shown to the subject on the computer monitor. The target zone could appear at any of four locations in the virtual finger's 90° workspace (18°, 36°, 54°, and 72°) and could be any of three widths (4°, 8°, and 16°), which were centered on the target location. This target zone and the virtual finger's current location were statically shown in red for a duration of one second at the start of every trial to ensure the subject's comprehension of the virtual finger's initial conditions (pre-visibility). During this time, the virtual finger did not move in response to applied finger torques and the subject's finger was held stationary at its current position in the workspace.

When the movement portion of the trial began, the color of the virtual finger workspace and the target zone changed from red to black, and the virtual finger's velocity was linearly ramped up to the value calculated from (2) over a period of 0.1 seconds. This short ramp was necessary to provide smooth proprioceptive motion feedback and was not noticed by subjects. As soon as the trial began, the subject attempted to move the virtual finger into the target zone as quickly and accurately as possible, using the currently available combination of motion feedback modalities.

Users were instructed to press the space bar on the computer keyboard with their left hand when they believed the virtual finger was inside the target zone, thereby terminating the trial. Subjects were asked to bring the virtual finger to rest before they pressed the space bar, but no software controls were implemented to ensure adherence to this request. In addition to letting the subject see the virtual finger's current position relative to the next target zone, the one-second pause between trials was used to record the time-history of the trial for later analysis.

A sample trial of the targeted movement task for the V+P condition appears in Fig. 6, showing finger torque  $\tau_f$ , virtual finger velocity  $\omega_{vf}$ , virtual finger position  $\theta_{vf}$ , and estimated real finger position  $\hat{\theta}_f$ . For this trial, the target zone was located at 72° and had a width of 16°, as indicated with gray dashed lines in the virtual finger position graph. The virtual finger began the trial from a location near 18° because this was its final position from the previous trial. Examining the  $\tau_f$  plot, we see that the subject's finger torque increased to an approximate maximum of 0.2 Nm about halfway through the trial and then diminished almost to zero. This torque profile successfully positioned the virtual finger inside the target zone, and the subject pressed the computer's space bar to end the trial after 1.803 seconds. This trial occurred during a set with proprioceptive motion feedback (P condition), so the subject's finger was moved to match the virtual finger ( $\hat{\theta}_f \cong \theta_{vf}$ ). If proprioceptive motion feedback had been withheld (NP condition), the finger would have remained near  $\hat{\theta}_f = 0^\circ$  for the entire set.

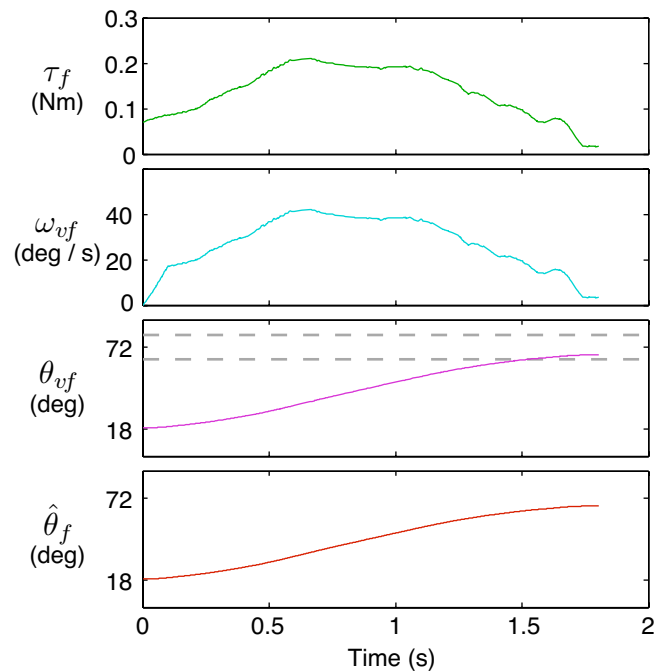

Fig. 6. Data from a sample V+P trial. The subject moved the virtual finger to the target zone by applying a bell-shaped finger torque profile.

#### F. Procedures

Experimental testing sessions began with an explanation of the nature of the experiment and the specific objectives of the targeted motion task. The conducted study included two additional types of feedback, visual and tactile binary indicators of task success, which are not reported here. After informed consent was obtained, the apparatus and hand rest were adjusted to fit the subject. The subject stood next to the experimental setup as pictured in Fig. 2 for the duration of the experiment.

The subject first performed five practice sets of twelve repetitions of the targeted movement task. Each of the five practice sets provided a different combination of the four feedback modalities being tested in the full study: practice set 1 was V+P with the two unreported binary feedback modes, set 2 was V+NP, set 3 was NV+P, and sets 4 and 5 were NV+NP plus one of the two unreported indicator feedback types. During the practice sets, the experimenter verbally reminded the subject to move the virtual finger quickly and accurately and to try to bring it to a stop before ending each trial. At the end of each practice set, the system returned the virtual finger to 0°, and the subject provided a five-point ease-of-use rating: how difficult or easy was it to control the movement of the virtual finger with the presented feedback combination? Subjects were required to remove their right hand from the apparatus and use the computer mouse to click on a rating button; this stipulation provided a brief rest period for the subject's finger and was used to re-zero the force sensor to mitigate the occurrence of thermally-induced sensor drift.

All subjects mastered the virtual targeting task and the experimental structure during the five practice sets. After completing the practice session, subjects began sets of data



collection trials. A full-factorial  $2 \times 2 \times 2 \times 2$  within-subjects design was employed; each subject completed sixteen experimental sets in random order, testing all combinations of the four two-level feedback factors being studied. This paper draws results from only four of these sets (NV+NP, NV+P, V+NP, and V+P), as the others included one or both of the unreported feedback types. Each experimental set consisted of twenty-four targeted movement trials, two repetitions at each target location-width combination. The targets appeared in random order and always changed location between successive trials. Other than the increased number of trials and randomized treatment presentation, the experimental procedure was identical to that of the practice session. When all of the sets were complete, the subject filled out a short questionnaire, providing comments on the tested feedback types and the experiment itself.

#### IV. RESULTS

The qualitative and quantitative data obtained from the human subject experiment were analyzed from several perspectives to uncover the most salient effects of visual and proprioceptive motion feedback on human control of targeted movement. For each treatment, the three measurements of highest interest are:  $e$ , the ease of use reported by the subject;  $\rho$ , the task completion success rate achieved by the subject; and  $s_{vf}$ , the speed at which the subject moved the virtual finger. The sections below present the results of these three measurements across subjects, including central tendency and analysis of variance.

##### A. Ease of use

Each subject provided a qualitative assessment of the ease of use of each treatment after performing the targeted motion task 24 times in a row with the specified set of motion feedback modalities (NV+NP, NV+P, V+NP, or V+P). For the purposes of analysis, ease of use,  $e$ , is treated as a nonparametric (ordinal) measurement, and the five ratings of *Very Difficult*, *Difficult*, *Moderate*, *Easy*, and *Very Easy* are valued at 1, 2, 3, 4, and 5 respectively. Median,  $m$ , mean,  $\bar{y}$ , and standard deviation,  $\sigma$ , are given for each of the four treatments in Table I. The Kruskal-Wallis test, a nonparametric one-way Analysis of Variance, was performed across the four treatments and showed that treatment type significantly affected the median ease-of-use rating provided by subjects ( $\chi^2(3, 48) = 42.6, p < 0.00001$ ).

Friedman's test, a nonparametric version of two-way Analysis of Variance, was performed on this data to separate the effects of visual and proprioceptive motion feedback. There was a significant main effect of visual motion feedback ( $\chi^2(1, 48) = 41.1, p < 0.00001$ ) and a significant main effect of proprioceptive motion feedback ( $\chi^2(1, 48) = 14.2, p = 0.0002$ ). As pictured in Fig. 7, both visual and proprioceptive motion feedback made the system easier to use, with the treatments ordered NV+NP, NV+P, V+NP, V+P from most difficult to easiest.

TABLE I  
EASE-OF-USE RATING ACROSS SUBJECTS.

		No Visual	Visual
		$e$	
No Proprioceptive	$m$	1	4
	$\bar{y}$ ( $\sigma$ )	1.08 (0.28)	4.00 (0.71)
Proprioceptive	$m$	2	4
	$\bar{y}$ ( $\sigma$ )	2.31 (0.75)	4.39 (0.51)

*Very Difficult*, *Difficult*, *Moderate*, *Easy*, and *Very Easy* are valued at 1, 2, 3, 4, and 5 respectively.

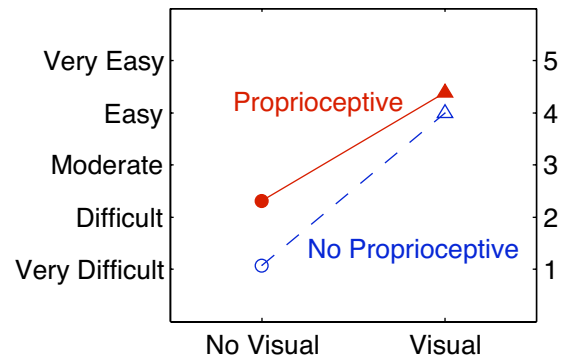

Fig. 7. Ease-of-use means. Both visual and proprioceptive motion feedback make the virtual finger easier to control.

##### B. Success rate

For each subject, the success rate  $\rho$  was calculated separately for each treatment as the proportion of trials that the virtual finger was inside the target zone when the subject ended the trial, giving  $0 \leq \rho \leq 1$ . Means and standard deviations for the four treatments are given in Table II. Subjects achieved poor success rates when completing the task without any motion feedback (NV+NP), and they performed it almost perfectly with both visual and proprioceptive feedback from the virtual finger (V+P). Because success rate is a proportion, it follows a binomial distribution, and its variance is not homogeneous; the standard deviation of low and high success rates is smaller than that of moderate success rates, as observed in the first column of each cell in Table II. Each success rate measurement was transformed by  $\sin^{-1}(\sqrt{\rho})$  to stabilize the variance, the standard practice for data that follow a binomial distribution [25]. The mean and standard deviation of transformed success rate are shown in the second column of each cell in the table, and the standard deviations are expectedly more uniform. The third column of each cell provides  $\rho^*$ , the inverse transform of the mean of the transformed data, which is a natural proportion.

A  $2 \times 2$  within subjects Analysis of Variance was used to analyze the transformed success rate data. There was a significant main effect of visual motion feedback ( $F(1, 48) = 492, p = 0$ ) and a significant main effect of proprioceptive motion feedback ( $F(1, 48) = 36.9, p < 0.000001$ ). The size

TABLE II  
NATURAL AND TRANSFORMED SUCCESS RATE ACROSS SUBJECTS.

		No Visual			Visual		
		$\rho$	$\sin^{-1}(\sqrt{\rho})$	$\rho^*$	$\rho$	$\sin^{-1}(\sqrt{\rho})$	$\rho^*$
No Proprioceptive	$\bar{y}$ ( $\sigma$ )	0.23 (0.11)	0.48 (0.14)	0.22	0.94 (0.06)	1.37 (0.16)	0.96
Proprioceptive	$\bar{y}$ ( $\sigma$ )	0.49 (0.13)	0.77 (0.13)	0.49	0.99 (0.03)	1.53 (0.10)	0.999

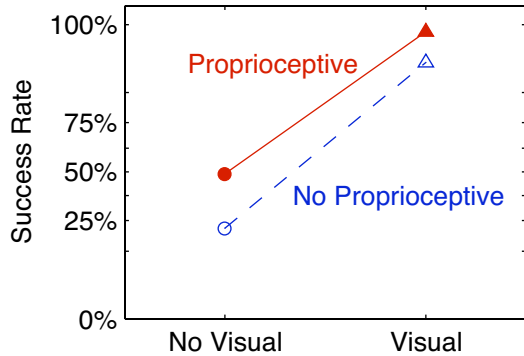

Fig. 8. Success rate means with transformed scale. Visual motion feedback substantially improves targeting accuracy, and proprioceptive motion feedback improves accuracy more modestly.

of each of these effects was calculated using the partial Eta squared method, giving  $\eta_p^2 = 0.91$  and  $\eta_p^2 = 0.43$  respectively. This statistical quantity gives the proportion of the effect plus error variance that is attributable to the effect: larger values of  $\eta_p^2$  indicate stronger effects, so visual motion feedback has a stronger effect on success rate than proprioceptive motion feedback. As seen by the near parallel traces in Fig. 8, which graphs  $\rho^*$  for each treatment, the interaction between visual and proprioceptive motion feedback was not significant at  $\alpha = 0.05$  ( $F(1, 48) = 2.89, p = 0.096$ ); thus, the success rate benefits of visual and proprioceptive motion feedback do not depend on the presence or absence of the other modality, though it should be noted that this conclusion relies on the employed variance-stabilizing transformation. Pairwise comparisons between the transformed success rate means using Tukey's method showed that all means are significantly different with  $\alpha = 0.05$ .

### C. Virtual finger speed

We initially expected the virtual finger movements tested in this study to follow Fitts' Law, a well-studied tool for evaluating targeted human motion [26]. Shannon's formulation of Fitts' Law predicts a linear relationship between index of difficulty and completion time,  $t_c$ ,

$$t_c = a + b \log_2 \left( \frac{A}{W} + 1 \right), \quad (7)$$

where  $A$  is the distance from the starting position to the center of the target, and  $W$  is the width of the target zone. The offset  $a$  and slope  $b$  are empirically determined for each

treatment using least squares. This analysis yielded a poor fit to the collected trial data: the mean of the correlation coefficient  $r$  between completion time  $t_c$  and index of difficulty  $\log_2 \left( \frac{A}{W} + 1 \right)$ , computed independently for all 52 treatment-subject combinations, was 0.58, and its standard deviation was 0.22. Furthermore Fitts' Law does not provide a good method for adjusting the index of difficulty for data with low success rates, as observed for the NV+NP and NV+P treatments, so this method of analysis was abandoned for this study.

Completion time was found to correlate much more strongly with the angular distance traveled by the virtual finger than with index of difficulty. We denote this distance metric  $\phi_{vf}$  and compute it from the  $n$  discretely recorded samples of virtual finger speed,  $s_{vf}$ , and elapsed time,  $t$ , via

$$\phi_{vf} = \sum_{k=2}^n s_{vf,k} (t_k - t_{k-1}), \quad (8)$$

where  $k$  is the sample index. The mean of the correlation coefficients between  $t_c$  and  $\phi_{vf}$  over all sets by all subjects was 0.78, and their standard deviation was 0.17, an improvement over index of difficulty. Statistical analyses were thus performed on average virtual finger speed, which was computed for each trial as

$$s_{vf,avg} = \frac{\phi_{vf}}{t_c}. \quad (9)$$

This measurement disregards any offset in the linear fit between virtual finger distance traveled and completion time but advantageously provides a speed measurement for every trial; the mean of the squared residuals of full subject-treatment-specific fits ( $t_c = a + b \phi_{vf}$ ) is 0.16 seconds, while the mean of the squared residuals of reduced fits to the same data ( $t_c = b \phi_{vf}$ ) is 0.25 seconds. For comparison, the mean squared residual of the full fits to index of difficulty given in (7) is 0.38 seconds, much larger than both of these values. Table III gives the means and standard deviations of average virtual finger speed for the four treatments, computed across subjects and trials.

A  $2 \times 2$  within subjects Analysis of Variance was used to analyze the average virtual finger speed data across subjects and trials. There was a significant main effect of visual motion feedback ( $F(1, 1244) = 57.1, p = 0, \eta_p^2 = 0.0437$ ) and a significant main effect of proprioceptive motion feedback ( $F(1, 1244) = 56.8, p = 0, \eta_p^2 = 0.0439$ ). However,

TABLE III

AVERAGE VIRTUAL FINGER SPEED ACROSS SUBJECTS AND TRIALS.

		No Visual	Visual
		$s_{vf,avg}$	$s_{vf,avg}$
No Proprioceptive	$\bar{y}$	24.3	26.5
	$(\sigma)$	(11.3)	(10.5)
Proprioceptive	$\bar{y}$	17.7	24.3
	$(\sigma)$	(9.9)	(9.6)

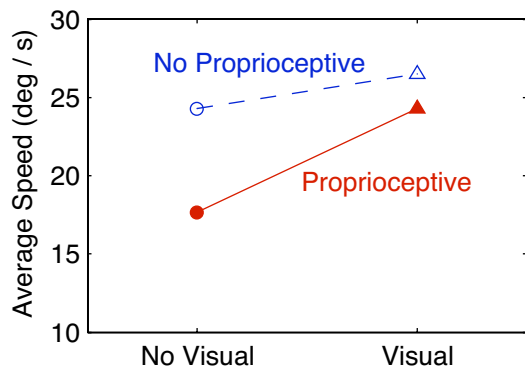

Fig. 9. Average virtual finger speed means. Visual and proprioceptive motion feedback have opposite effects on the speed at which subjects move the virtual finger; visual feedback increases  $s_{vf}$ , while proprioceptive feedback decreases it.

the interaction between visual and proprioceptive motion feedback was also found to be significant ( $F(1, 1244) = 14.6, p = 0.0001, \eta_p^2 = 0.0116$ ), as can be observed by the skewed angles of the traces in Fig. 9. Pairwise comparisons between the average virtual finger speed means using Tukey's method showed that all treatment means except the pair [NV+NP & V+P] are significantly different, using  $\alpha = 0.05$ . For both levels of proprioceptive feedback, subjects moved the virtual finger more quickly when they had visual motion feedback than when they did not. Inversely, for both levels of visual feedback, subjects moved the virtual finger more slowly when they had proprioceptive motion feedback than when they did not.

To further understand the effects of visual and proprioceptive motion feedback on movement control, we also analyzed the speed at which the virtual finger was moving at the end of each trial,  $s_{vf,final}$ . Table IV gives the means and standard deviations of final virtual finger speed for the four treatments, computed across subjects and trials. A  $2 \times 2$  within subjects Analysis of Variance was used to analyze the final virtual finger speed data. There was a significant main effect of visual motion feedback ( $F(1, 1244) = 104.1, p = 0, \eta_p^2 = 0.018$ ) and a significant main effect of proprioceptive motion feedback ( $F(1, 1244) = 56.8, p = 0, \eta_p^2 = 0.077$ ). The interaction between visual and proprioceptive motion feedback was not found to be significant ( $F(1, 1244) = 0.29, p = 0.59$ ), as can be observed by the near-parallel orientation of the traces in Fig. 10.

TABLE IV

FINAL VIRTUAL FINGER SPEED ACROSS SUBJECTS AND TRIALS.

		No Visual	Visual
		$s_{vf,final}$	$s_{vf,final}$
No Proprioceptive	$\bar{y}$	6.4	8.5
	$(\sigma)$	(10.0)	(8.5)
Proprioceptive	$\bar{y}$	2.5	4.2
	$(\sigma)$	(2.7)	(4.2)

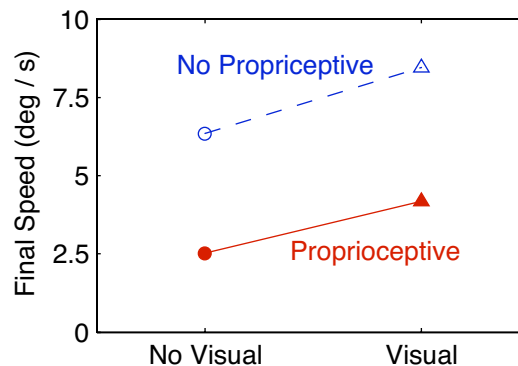

Fig. 10. Final virtual finger speed means. Proprioceptive motion feedback caused subjects to slow the virtual finger down more before ending a trial. In contrast, visual motion feedback increases the final virtual finger speed.

#### D. Speed/accuracy trade-off

We were lastly interested in the relationship between movement speed and positioning accuracy. Fig. 11 plots task completion accuracy,  $\rho$ , against mean average virtual finger speed,  $\bar{s}_{vf,avg}$ , for every combination of subject and treatment. As listed in the accompanying key, marker shape indicates whether visual motion feedback was provided, and marker fill denotes whether proprioceptive motion feedback was provided. Subject performance is strongly clustered by treatment, demonstrating that changes in the availability of motion feedback from the virtual finger caused different individuals to choose similar trade-offs between speed and accuracy.

Despite the clustering, success rate is seen to vary substantially between subjects; when subject is included as a factor in the Analysis of Variance from Section IV-B, it is found to have a significant effect ( $F(12, 36) = 2.26, p = 0.0295, \eta_p^2 = 0.429$ ). In this updated ANOVA on transformed success rate, the main effects of visual and proprioceptive feedback are still found to be significant with  $p = 0$ , and their effect sizes  $\eta_p^2$  are 0.947 and 0.574 respectively. Including subject as a factor does not make the interaction between feedback types a significant effect on success rate ( $F(1, 36) = 3.79, p = 0.0593$ ).

The mean computed value of average virtual finger speed is also seen to vary substantially between subjects in Fig. 11. When subject is included as a factor in the Analysis of Variance on  $s_{vf,avg}$  from Section IV-C, it is found to have a significant effect ( $F(12, 1232) = 36.8, p = 0, \eta_p^2 = 0.264$ ). In this updated ANOVA, the main effects of visual and

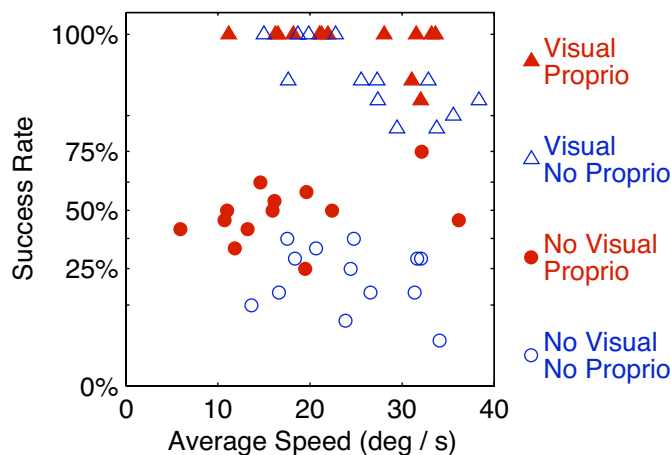

Fig. 11. Success rate versus mean average virtual finger speed for each subject-treatment combination, with transformed success rate scale. The clustering of the symbols by treatment indicates that the thirteen different subjects made similar trade-offs between accuracy and speed.

proprioceptive feedback and their interaction are each still significant ( $p = 0$ ), and their effect sizes  $\eta_p^2$  are 0.0584, 0.0587, and 0.0157 respectively.

## V. DISCUSSION

This study was designed to clarify our understanding of how humans harness visual and proprioceptive sources of movement information when trying to control a non-self entity like a prosthesis. A wealth of data was collected, and the three most salient trends from our current analysis were presented in the foregoing section. We believe these results shed light on general human movement capabilities, and we discuss some of our chief observations and interpretations in this section.

### A. Ease of use

We believe that the ease-of-use metric is the most important piece of collected data because it most purely captures the experience of the user. If a feedback modality is difficult to use, it will never achieve widespread acceptance, regardless of the performance gains it may enable. As expected, visual motion feedback made the virtual finger much easier to control, but direct vision is not always available during the use of a prosthesis, such as when the wearer is putting on a hat. Artificial proprioception has the potential to aid prosthesis users in such situations; our study showed that proprioceptive motion feedback made the virtual finger significantly easier to control in both sighted and unsighted conditions. As with natural human limbs, proprioception significantly facilitates human control of non-self movement.

During the practice session, we anecdotally observed large variations in subjects' level of comfort when they first tested the NV+P condition. Some individuals expressed amazement that they were being asked to control movement without visual feedback, but they became more accustomed to it during the twelve practice trials. Other individuals quickly accepted the challenge of the task and performed well from the beginning. These subject-to-subject differences can be observed in

the high standard deviation for NV+P ease of use, as listed in Table I. It is relevant to observe from Fig. 11 that success rate during the experiment also varied widely for this treatment; some subjects achieved only about 25% success, while many others scored higher than 50%. Proprioception is a very natural method for perceiving motion, and we believe that prior experience may have made it easier for some subjects to utilize during the experiment. A more extensive training session might be warranted for future studies that include treatments with only proprioceptive motion feedback.

### B. Success rate

Our first observation on the success rate results is that they strongly resemble the trends in reported ease of use; the traces in Figs. 7 and 8 have very similar shapes. We hypothesize that subjects were attuned to how accurately the provided feedback allowed them to perform the task, which may have influenced their qualitative ease-of-use rating. One should note, though, that the twelve unreported experimental sets all included visual and/or tactile indicators of task completion success. Subjects may have been more focused on this success rate than would have occurred in a stand-alone study.

We found that the success-rate means between all pairs of treatments were significantly different from one another. Visual feedback had a very strong effect on success rate, while proprioceptive motion feedback had a more moderate influence. Most notably, proprioceptive motion feedback significantly improved subjects' performance even when vision was present, corroborating the between-subject results of Ghez et al. [13]. We believe these findings indicate that artificial proprioception could improve the ability of prosthesis users to control their devices even under direct vision. Preliminary examination of the data indicates that target zone size affected the success of individual trials, with smaller targets being more difficult to hit; future analysis will investigate this trend to determine whether visual and proprioceptive motion feedback provide different levels of assistance depending on task difficulty.

Our last observation on task success rates is that the mean performance for the NV+NP condition is far better than would be achieved by random motor output, if we were to assume an equal probability of moving the virtual finger to any location between its starting position and the edge of its workspace that lies beyond the current target. We conjecture that subjects achieved this relatively high performance level by developing an internal model of the virtual finger's dynamics, which they could calibrate via the visual feedback of virtual finger motion provided after every trial, regardless of treatment. Open-loop motor output in such a simple one-dimensional environment can achieve the goal at hand – a few subjects scored as high as 40% on the NV+NP condition – but it is not likely to suffice for motions with more degrees of freedom and greater variations in system behavior, as occur with prosthesis use.

### C. Virtual finger speed

In this study, visual and proprioceptive movement feedback were found to have opposite effects on the speed with which subjects moved an external entity (the virtual finger). As the average speed computations include all trials, both successes and failures, it is inadvisable to interpret higher speeds as unilaterally desirable; rather, we believe we must interpret the results from the perspective of movement control, which requires both speed and accuracy. As can be seen in Fig. 11, subjects moved the virtual finger quickly in the no feedback (NV+NP) treatment, but they achieved relatively low success rates because they did not always know where the virtual finger was in the workspace. With the addition of vision alone (V+NP), subjects moved the virtual finger even more quickly and with far better control. This treatment falls in the category of visual servoing, which relies on inversion of an accurate forward dynamical model moderated by visual movement feedback. The more complicated, nonlinear, multi-dimensional dynamics associated with a prosthetic upper limb are far more difficult to control than the virtual finger we tested, which may further indicate the potential value of proprioceptive motion feedback for prostheses.

In both NP conditions, the apparatus remained stationary; thus the user was applying high forces in an isometric condition. Subjects moved more slowly in the respective P conditions, which indicates they were applying lower mean forces to the apparatus. This trend can be partially attributed to the dynamics of the system: when proprioceptive motion feedback is available, fingertip forces applied in the positive (counter-clockwise) direction cause the apparatus to retreat away from the finger. This movement diminishes the applied force because the finger and apparatus are not rigidly coupled; rather they are joined by the compliance of the Velcro strap and the finger pad itself. In the opposite case, negative (clockwise) fingertip forces are applied via tension in the Velcro strap; when the apparatus moves to track the virtual finger's movement response, strap tension is diminished, and fingertip forces decrease. As shown by Wu et al., humans have a significantly degraded ability to control force output at finger movement velocities higher than 2 cm/s, relative to the isometric case [15]. This linear velocity corresponds to an approximate angular rate of  $\omega_{vf} = 15.7$  deg/s for our apparatus, which is below the mean virtual finger velocity observed in all treatments. This limitation on human force control is likely a contributing factor to the generally lower velocities subjects employed in NP conditions, but the magnitude of its effect can only be determined by conducting a study that dynamically decouples finger force output from proprioceptive motion display.

We hypothesize that the slowing effect of proprioceptive motion feedback may also partially stem from a difference in the salience of velocity between visual and proprioceptive modalities. This hypothesis was inspired by the following comment, which was provided by a naïve subject on the written end-of-study feedback form: "Proprioception is hardest [to use of the four tested modalities] because the position

feedback is not precise (I can't tell where my finger is, especially close to 90°). But proprioception does give great velocity feedback." Perhaps the true value of proprioceptive feedback is the velocity component, which was not separable from position feedback in this study. Another possible explanation for proprioceptive feedback's observed speed-attenuating effect is that velocity is more saliently perceived via proprioception than via vision. More research is needed to unravel this issue and determine the exact contribution of proprioception to movement control.

Our final observation on the virtual finger speed results is that subjects adopted different movement patterns in P versus NP conditions. Analysis on  $\omega_{vf,final}$  showed that subjects slowed the virtual finger much more effectively at the end of the trials when proprioceptive motion feedback was provided. Regardless of the cause for this difference, a movement that returns to zero or near-zero velocity will typically have a lower mean velocity than one that traverses the same distance and terminates at a higher speed. The objective of stopping the virtual finger before pressing the space bar to end the trial was clearly communicated to all subjects during the description of the study, but subjects did not strictly adhere to this goal when proprioceptive feedback was absent. We observe that it is natural and necessary to bring one's limb to rest at the end of a real finger pointing movement; our experiment did not impose any restrictions of this kind, so subjects may have believed that slowing the virtual finger down was not required. They may also have disliked the abrupt halting that the apparatus undergoes when a P trial is terminated at high speed; in retrospect, the virtual finger should have been slowed down to zero velocity with constant acceleration after the end of every trial to avoid this effect. Further analysis and future work will be needed to fully understand this observed trend.

## VI. CONCLUSION

This research is centered on understanding the separate and synergistic influences of visual and proprioceptive motion feedback in human control of non-self movement. We developed an experimental setup in which applied finger forces determine the velocity of a one-degree-of-freedom virtual finger as an analogy to the control of a powered prosthetic upper limb. This apparatus was used to conduct a human-subject study on user control of virtual finger movement. We varied the methods by which subjects could discern virtual finger movement, including both visual and proprioceptive modalities, and we tested subject performance in a targeting task.

The thirteen study participants quickly became proficient at pointing the virtual finger at the displayed targets due to the simple muscular mapping between thought and virtual finger movement. The notable exception was the NV+NP condition; in the absence of both visual and proprioceptive feedback, subjects struggled to accurately control the motion of the virtual finger. This feedback configuration is analogous to using a modern prosthesis with one's eyes closed: one would generally not trust such an arrangement for

performing important tasks like picking up a crystal vase or scratching one's own ear. As expected, the addition of visual motion feedback enabled excellent performance. The more interesting finding, however, is that proprioceptive feedback enabled improved performance and usability over the non-proprioceptive case for *both* sighted and unsighted operation. This result supports the potential usefulness of proprioceptive movement feedback for prosthetics, which we believe is an important avenue for future work.

Further research should also focus on more fully understanding the role of proprioception in general control of non-self movement. We will start by analyzing the data taken from experimental sets with the two binary feedback indicators, looking for their independent effects and any promising synergies they may evoke with the continuous feedback types discussed here. Additional human-subject experiments are also warranted to separate out the biomechanical finger movement and neural proprioception effects that were somewhat coupled in this study. The current study treated proprioception as a single afferent entity, but human proprioceptive capabilities are truly derived from an array of biological sensors. Future prosthesis system design would benefit from knowing which of these pathways is most essential for controlling non-self movement, since simultaneous stimulation of all neural channels is not yet feasible. For a near-term solution, research in our laboratory will be investigating vibration, pressure, skin stretch, and unobtrusive auditory cues to develop an effective method of sensory substitution for proprioceptive motion feedback.

## VII. ACKNOWLEDGMENTS

The authors thank Jonathan Fiene and the anonymous reviewers for the useful comments they provided on earlier drafts of this manuscript. This work was supported by the Johns Hopkins University, an NSF Graduate Research Fellowship, and DARPA Grant N66001-06-C-8005.

## REFERENCES

- [1] D. J. Atkins, D. C. Y. Heard, and W. H. Donovan, "Epidemiologic overview of individuals with upper-limb loss and their reported research priorities," *Journal of Prosthetics and Orthotics*, vol. 8, no. 1, pp. 2–11, 1996.
- [2] A. J. Windebank, M. D. Blexrud, P. J. Dyck, J. R. Daube, and J. L. Karnes, "The syndrome of acute sensory neuropathy: Clinical features and electrophysiologic and pathologic changes," *Neurology*, vol. 40, no. 4, pp. 584–591, Apr. 1990.
- [3] J. Hu, A. Zhang, Z. Lin, and J. Zhou, "Congenital insensitivity to pain with anhidrosis and progressing acro-osteolysis: a case report with 7-year follow-up," *Chinese Medical Journal (English)*, vol. 119, no. 24, pp. 2134–2137, Dec. 2006.
- [4] M. Björklund, "Effects of repetitive work on proprioception and of stretching on sensory mechanisms," Medical Dissertation, UMEÅ University, 2004.
- [5] D. F. Collins and A. Prochazka, "Movement illusions evoked by ensemble cutaneous input from the dorsum of the human hand," *Journal of Physiology*, vol. 496, no. 3, pp. 857–871, 1996.
- [6] D. F. Collins, K. M. Refshauge, G. Todd, and S. C. Gandevia, "Cutaneous receptors contribute to kinesthesia at the index finger, elbow, and knee," *Journal of Neurophysiology*, vol. 94, no. 3, pp. 1699–1706, 2005.
- [7] S. C. Gandevia, J. L. Smith, M. Crawford, U. Proske, and J. L. Taylor, "Motor commands contribute to human position sense," *Journal of Physiology*, vol. 571, no. 3, pp. 703–710, 2006.
- [8] B. R. Brewster, M. Fagan, R. L. Klatzky, and Y. Matsuoka, "Perceptual limits for a robotic rehabilitation environment using visual feedback distortion," *IEEE Transactions on Neural Systems and Rehabilitation Engineering*, vol. 13, no. 1, pp. 1–11, 2005.
- [9] D. I. McCloskey, "Kinesthetic sensibility," *Physiological Reviews*, vol. 58, no. 4, pp. 763–820, Oct. 1978.
- [10] J. A. S. Kelso, "Motor control mechanisms underlying human movement reproduction," *Journal of Experimental Psychology: Human Perception and Performance*, vol. 3, no. 4, pp. 529–543, Nov. 1977.
- [11] D. D. Larish, C. M. Volp, and S. A. Wallace, "An empirical note on attaining a spatial target after distorting the initial conditions of movement via muscle vibration," *Journal of Motor Behavior*, vol. 16, no. 1, pp. 76–83, 1984.
- [12] G. Robles-De-La-Torre, "The importance of the sense of touch in virtual and real environments," *IEEE Multimedia*, vol. 13, no. 3, pp. 24–30, 2006.
- [13] C. Ghez, J. Gordon, M. F. Ghilardi, C. N. Christakos, and S. E. Cooper, "Roles of proprioceptive input in the programming of arm trajectories," *Cold Spring Harbor Symposium on Quantitative Biology*, vol. 55, pp. 837–847, Dec. 1990.
- [14] H. Z. Tan, M. A. Srinivasan, B. Eberman, and B. Cheng, "Human factors for the design of force-reflecting haptic interfaces," in *Proc. ASME Dynamic Systems and Controls Division*, vol. 55, no. 1, 1994, pp. 353–359.
- [15] M. Wu, J. J. Abbott, and A. M. Okamura, "Effects of velocity on human force control," in *Proc. IEEE Symposium on Haptic Interfaces for Virtual Environments and Teleoperator Systems*, Mar. 2005, pp. 73–79.
- [16] T. A. Kuiken, L. A. Miller, R. D. Lipschutz, K. A. Stubblefield, and G. A. Dumanian, "Prosthetic command signals following targeted hyper-reinnervation nerve transfer surgery," in *Proc. IEEE International Conference of the Engineering in Medicine and Biology Society*, Sept. 2005, pp. 7652–7655.
- [17] G. S. Dhillon and K. W. Horch, "Direct neural sensory feedback and control of a prosthetic arm," *IEEE Transactions on Neural Systems and Rehabilitation Engineering*, vol. 13, no. 4, pp. 468–472, Dec. 2005.
- [18] M. C. Carrozza, F. Vecchi, F. Sebastiani, G. Cappiello, S. Roccella, M. Zecca, R. Lazzarini, and P. Dario, "Experimental analysis of an innovative prosthetic hand with proprioceptive sensors," in *Proc. IEEE International Conference on Robotics and Automation*, Sept. 2003, pp. 2230–2235.
- [19] C. Pylatiuk, S. Mounier, A. Kargov, S. Schulz, and G. Bretthauer, "Progress in the development of a multifunctional hand prosthesis," in *Proc. IEEE International Conference of the Engineering in Medicine and Biology Society*, Sept. 2004, pp. 4260–4263.
- [20] P. E. Patterson and J. A. Katz, "Design and evaluation of a sensory feedback system that provides grasping pressure in a myoelectric hand," *Journal of Rehabilitation Research*, vol. 29, no. 1, pp. 1–8, 1992.
- [21] S. G. Meek, S. C. Jacobsen, and P. P. Goulding, "Extended physiologic tactation: design and evaluation of a proportional force feedback system," *Journal of Rehabilitation Research and Development*, vol. 26, no. 3, pp. 53–62, 1989.
- [22] K. A. Kaczmarek, J. G. Webster, P. B. y Rita, and W. J. Tompkins, "Electrotactile and vibrotactile displays for sensory substitution systems," *IEEE Transactions on Biomedical Engineering*, vol. 38, no. 1, pp. 1–16, Jan. 1991.
- [23] R. Taylor, P. Jensen, L. Whitcomb, A. Barnes, R. Kumar, D. Stoianovici, P. Gupta, Z. Wang, E. deJuan, and L. Kavoussi, "A steady-hand robotic system for microsurgical augmentation," *International Journal of Robotics Research*, vol. 18, no. 12, pp. 1201–1210, Dec. 1999.
- [24] R. Q. V. der Linde, P. Lammertse, E. Frederiksen, and B. Ruiters, "The HapticMaster, a new high-performance haptic interface," in *Proc. EuroHaptics Conference*, S. A. Wall, B. Riedel, A. Crossan, and M. R. McGee, Eds., July 2002, pp. 1–5.
- [25] W. Mendenhall and T. Sincich, *Statistics for Engineering and the Sciences*, 4th ed. Prentice Hall, 1995, ch. 12, p. 652.
- [26] P. M. Fitts, "The information capacity of the human motor system in controlling the amplitude of movement," *Journal of Experimental Psychology: General*, vol. 121, no. 3, pp. 262–269, 1992.