



University of Pennsylvania
ScholarlyCommons

Departmental Papers (MEAM)

Department of Mechanical Engineering & Applied
Mechanics

June 2002

An SVD-Based Projection Method for Interpolation on $SE(3)$

Calin Belta
University of Pennsylvania

R. Vijay Kumar
University of Pennsylvania, kumar@grasp.upenn.edu

Follow this and additional works at: http://repository.upenn.edu/meam_papers

Recommended Citation

Belta, Calin and Kumar, R. Vijay, "An SVD-Based Projection Method for Interpolation on $SE(3)$ " (2002). *Departmental Papers (MEAM)*. 10.
http://repository.upenn.edu/meam_papers/10

Copyright 2002 IEEE. Reprinted from *IEEE Transactions on Robotics and Automation*, Volume 18, Issue 3, June 2002, pages 334-345.
Publisher URL: <http://ieeexplore.ieee.org/xpl/tocresult.jsp?isNumber=21926&puNumber=70>

This material is posted here with permission of the IEEE. Such permission of the IEEE does not in any way imply IEEE endorsement of any of the University of Pennsylvania's products or services. Internal or personal use of this material is permitted. However, permission to reprint/republish this material for advertising or promotional purposes or for creating new collective works for resale or redistribution must be obtained from the IEEE by writing to pubs-permissions@ieee.org. By choosing to view this document, you agree to all provisions of the copyright laws protecting it.

An SVD-Based Projection Method for Interpolation on $SE(3)$

Abstract

This paper develops a method for generating smooth trajectories for a moving rigid body with specified boundary conditions. Our method involves two key steps: 1) the generation of optimal trajectories in $GA^+(n)$, a subgroup of the affine group in \mathbf{R}^n and 2) the projection of the trajectories onto $SE(3)$, the Lie group of rigid body displacements. The overall procedure is invariant with respect to both the local coordinates on the manifold and the choice of the inertial frame. The benefits of the method are threefold. First, it is possible to apply any of the variety of well-known efficient techniques to generate optimal curves on $GA^+(n)$. Second, the method yields approximations to optimal solutions for general choices of Riemannian metrics on $SE(3)$. Third, from a computational point of view, the method we propose is less expensive than traditional methods.

Keywords

Interpolation, Lie groups, trajectory generation

Comments

Copyright 2002 IEEE. Reprinted from *IEEE Transactions on Robotics and Automation*, Volume 18, Issue 3, June 2002, pages 334-345.

Publisher URL: <http://ieeexplore.ieee.org/xpl/tocresult.jsp?isNumber=21926&puNumber=70>

This material is posted here with permission of the IEEE. Such permission of the IEEE does not in any way imply IEEE endorsement of any of the University of Pennsylvania's products or services. Internal or personal use of this material is permitted. However, permission to reprint/republish this material for advertising or promotional purposes or for creating new collective works for resale or redistribution must be obtained from the IEEE by writing to pubs-permissions@ieee.org. By choosing to view this document, you agree to all provisions of the copyright laws protecting it.

An SVD-Based Projection Method for Interpolation on $SE(3)$

Calin Belta, *Student Member, IEEE*, and Vijay Kumar, *Senior Member, IEEE*

Abstract—This paper develops a method for generating smooth trajectories for a moving rigid body with specified boundary conditions. Our method involves two key steps: 1) the generation of optimal trajectories in $GA^+(n)$, a subgroup of the affine group in \mathbb{R}^n and 2) the projection of the trajectories onto $SE(3)$, the Lie group of rigid body displacements. The overall procedure is invariant with respect to both the local coordinates on the manifold and the choice of the inertial frame. The benefits of the method are threefold. First, it is possible to apply any of the variety of well-known efficient techniques to generate optimal curves on $GA^+(n)$. Second, the method yields approximations to optimal solutions for general choices of Riemannian metrics on $SE(3)$. Third, from a computational point of view, the method we propose is less expensive than traditional methods.

Index Terms—Interpolation, Lie groups, trajectory generation.

I. INTRODUCTION

WE ADDRESS the problem of finding a smooth motion that interpolates between two given positions and orientations. This problem finds applications in robotics and computer graphics. The problem is well understood in Euclidean spaces [1]–[3], but it is not clear how these techniques can be generalized to curved spaces. There are two main issues that need to be addressed, particularly on non-Euclidean spaces. It is desirable that the computational scheme be independent of the description of the space and invariant with respect to the choice of the coordinate systems used to describe the motion. Secondly, the smoothness properties and the optimality of the trajectories need to be considered.

Shoemake [4] proposed a scheme for interpolating rotations with Bezier curves based on the spherical analog of the de Casteljau algorithm. This idea was extended by Ge and Ravani [5] and Park and Ravani [6] to spatial motions. The focus in these papers is on the generalization of the notion of interpolation from the Euclidean space to a curved space.

Another class of methods is based on the representation of Bezier curves with Bernstein polynomials. Ge and Ravani [7] used the dual-unit quaternion representation of $SE(3)$ and subsequently applied Euclidean methods to interpolate in

this space. Jütler [8] formulated a more general version of the polynomial interpolation by using dual (instead of dual unit) quaternions to parameterize $SE(3)$. In such a parameterization, an element of $SE(3)$ corresponds to a whole equivalence class of dual quaternions. Srinivasan [9] and Jütler [10] propose the use of spatial rational B-splines for interpolation. Park and Kang [11] derived a rational interpolating scheme for the group of rotations $SO(3)$ by representing the group with Cayley parameters and using Euclidean methods in this parameter space. Marthinsen [12] suggests the use of Hermite interpolation and the use of truncated inverse of the differential of the exponential mapping and the truncated Baker–Campbell–Hausdorff formula to simplify the construction of interpolation polynomials. The advantage of these methods is that they produce rational curves.

It is worth noting that all these works (with the exception of [6]) use a particular parameterization of the group and do not discuss the invariance of their methods. In contrast, Noakes *et al.* [13] derived the necessary conditions for cubic splines on general manifolds without using a coordinate chart. These results are extended in [14] to the dynamic interpolation problem. Necessary conditions for higher order splines are derived in Camarinha *et al.* [15]. A coordinate-free formulation of the variational approach was used to generate shortest paths and minimum acceleration and jerk trajectories on $SO(3)$ and $SE(3)$ in [16]. However, analytical solutions are available only in the simplest of cases, and the procedure for solving optimal motions, in general, is computationally intensive. If optimality is sacrificed, it is possible to generate bi-invariant trajectories for interpolation and approximation using the exponential map on the Lie algebra [17]. While the solutions are of closed form, the resulting trajectories have no optimality properties. In contrast, optimality is taken into account in [18], where Newton and conjugate gradient algorithms are developed into the more general framework of Grassmann and Stiefel manifolds.

In this paper, we build on previous work [13], [15]–[17] to generate smooth curves. We pursue a geometric approach and require that our results be invariant with respect to the choice of reference frames and independent of the parameterization of the manifold. Our approach is defining a metric on the group of rigid body displacements which has physical significance (induces the kinetic energy of the moving body as a norm). The bi-invariant metric on $SO(n)$ [19] and the left invariant metric proposed by Park and Brockett [20] are special cases of our general treatment. Also, this paper generalizes our preliminary results presented in [21].

We first show that a left or right invariant metric on $SO(n)$ ($SE(n)$) is inherited from the ambient manifold

Manuscript received September 23, 2001; revised January 20, 2002. This paper was recommended for publication by Associate Editor G. Oriolo and Editor S. Hutchinson upon evaluation of the reviewers' comments. This paper was presented at the Ball 2000 Symposium Commemorating the Legacy, Works, and Life of Sir Robert Stawell Ball, University of Cambridge, Cambridge, U.K., July 9–11, 2000.

The authors are with the General Robotics, Automation, Sensing, and Perception (GRASP) Laboratory, University of Pennsylvania, Philadelphia, PA 19104-6228 USA (e-mail: calin@grasp.cis.upenn.edu; kumar@grasp.cis.upenn.edu).

Publisher Item Identifier S 1042-296X(02)05183-2.

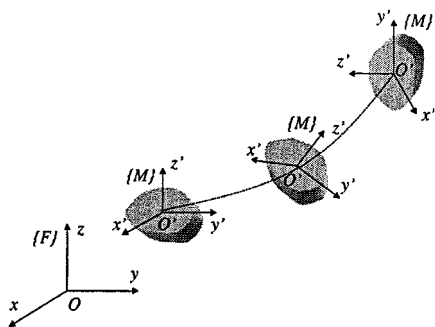

Fig. 1. Inertial (fixed) frame and moving frame attached to the rigid body.

$GL^+(n)$ ($GA^+(n)$) equipped with the appropriate metric. Next, a projection operator that projects points and curves from the ambient manifold onto $SO(n)$ ($SE(n)$) is defined. The uniqueness and smoothness of the projected trajectory are discussed. Several examples are presented to illustrate how curves generated in the ambient manifold can be projected to get near-optimal results on $SO(n)$ and $SE(n)$, especially when the excursion of the trajectories is “small.” In certain cases, we are also able to establish quantitative results that measure the closeness of the generated trajectory to the optimal trajectory [22].

II. BACKGROUND

A. Lie Groups $SO(3)$ and $SE(3)$

Let $GL^+(n)$ denote the set of all positive-definite $n \times n$ real matrices and $SO(n)$ the subset of GL^+ , defined as

$$SO(n) = \{R \mid R \in GL^+(n), RR^T = I\}.$$

Let

$$GA^+(n) = \left\{ B \mid B = \begin{bmatrix} M & d \\ 0 & 1 \end{bmatrix}, M \in GL^+(n); d \in \mathbb{R}^n \right\}$$

and

$$SE(n) = \left\{ A \mid A = \begin{bmatrix} R & d \\ 0 & 1 \end{bmatrix}, R \in SO(n); d \in \mathbb{R}^n \right\}.$$

$GL^+(n)$, $SO(n)$, $GA^+(n)$, and $SE(n)$ have the structure of a group under matrix multiplication. Moreover, matrix multiplication and inversion are both smooth operations, which make all $GL^+(n)$, $SO(n)$, $GA^+(n)$, and $SE(n)$ Lie groups.

$GL^+(n)$ and $GA^+(n)$ are subgroups of the general linear group $GL(n)$ (the set of all nonsingular $n \times n$ matrices) and of the affine group $GA(n) = GL(n) \times \mathbb{R}^n$, respectively. $SO(n)$ is referred to as the special orthogonal group or the rotation group on \mathbb{R}^n . $SE(n)$ is the special Euclidean group, and is the set of all rigid displacements in \mathbb{R}^n .

Special consideration will be given to $SO(3)$ and $SE(3)$. Consider a rigid body moving in free space. Assume any inertial reference frame $\{F\}$ fixed in space and a frame $\{M\}$ fixed to the body at point O' as shown in Fig. 1. At each instance, the configuration (position and orientation) of the rigid body can be described by a homogeneous transformation matrix $A \in SE(3)$ corresponding to the displacement from frame $\{F\}$ to frame $\{M\}$.

On any Lie group the tangent space at the group identity has the structure of a Lie algebra. The Lie algebras of $SO(3)$ and $SE(3)$ denoted by $so(3)$ and $se(3)$, respectively, are given by

$$so(3) = \left\{ \hat{\omega} \mid \hat{\omega} \in \mathbb{R}^{3 \times 3}, \hat{\omega}^T = -\hat{\omega} \right\}$$

$$se(3) = \left\{ S = \begin{bmatrix} \hat{\omega} & v \\ 0 & 0 \end{bmatrix} \mid \hat{\omega} \in \mathbb{R}^{3 \times 3}, v \in \mathbb{R}^3; \hat{\omega}^T = -\hat{\omega} \right\}$$

where $\hat{\cdot}$ is the skew-symmetric operator.

Given a curve

$$A(t): [-a, a] \rightarrow SE(3), A(t) = \begin{bmatrix} R(t) & d(t) \\ 0 & 1 \end{bmatrix}$$

an element $S(t)$ of the Lie algebra $se(3)$ can be identified with the tangent vector $\dot{A}(t)$ at an arbitrary point t by

$$S(t) = A^{-1}(t)\dot{A}(t) = \begin{bmatrix} \hat{\omega}(t) & R^T \dot{d} \\ 0 & 0 \end{bmatrix} \quad (1)$$

where

$$\hat{\omega}(t) = R^T(t)\dot{R}(t) \quad (2)$$

is the corresponding element from $so(3)$.

A curve on $SE(3)$ physically represents a motion of the rigid body. If $\{\omega(t), v(t)\}$ is the vector pair corresponding to $S(t)$, then ω physically corresponds to the angular velocity of the rigid body while v is the linear velocity of the origin O' of the frame $\{M\}$, both expressed in the frame $\{M\}$. In kinematics, elements of this form are called twists and $se(3)$ thus corresponds to the set of all twists. The twist $S(t)$ computed from (1) does not depend on the choice of the inertial frame $\{F\}$.

Since $so(3)$ is a vector space, any element can be expressed as a 3×1 vector of components corresponding to a chosen basis. The standard basis for $so(3)$ is

$$L_1^o = \hat{e}_1 \quad L_2^o = \hat{e}_2 \quad L_3^o = \hat{e}_3$$

where $\{e_1, e_2, e_3\}$ is the canonical base in \mathbb{R}^3 .

L_1^o , L_2^o , and L_3^o represent instantaneous rotations about the Cartesian axes x , y , and z , respectively. The components of a $\hat{\omega} \in so(3)$ in this basis are given precisely by the angular velocity vector ω .

The standard basis for $se(3)$ is

$$L_1 = \begin{bmatrix} L_1^o & 0 \\ 0 & 0 \end{bmatrix}$$

$$L_2 = \begin{bmatrix} L_2^o & 0 \\ 0 & 0 \end{bmatrix}$$

$$L_3 = \begin{bmatrix} L_3^o & 0 \\ 0 & 0 \end{bmatrix}$$

$$L_4 = \begin{bmatrix} 0 & e_1 \\ 0 & 0 \end{bmatrix}$$

$$L_5 = \begin{bmatrix} 0 & e_2 \\ 0 & 0 \end{bmatrix}$$

$$L_6 = \begin{bmatrix} 0 & e_3 \\ 0 & 0 \end{bmatrix}.$$

The twists L_4 , L_5 and L_6 represent instantaneous translations along the Cartesian axes x , y , and z , respectively. The components of a twist $S \in se(3)$ in this basis are given precisely by the components of the velocity vector pair $\{\omega, v\}$.

B. Left Invariant Vector Fields

A left invariant differentiable vector field, X , on $SE(3)$ is obtained by left translation of an element $S \in se(3)$. The value of the vector field X at an arbitrary point $A \in SE(3)$ is given by $X(A) = AS$. Since the vectors L_1, L_2, \dots, L_6 are a basis for the Lie algebra $se(3)$, any vector field X can be expressed as $X = \sum_{i=1}^6 X^i(AL_i)$, where the coefficients X^i vary over the manifold. If the coefficients are constants, then X is left invariant. By defining $\omega = [X^1, X^2, X^3]^T$, $v = [X^4, X^5, X^6]^T$, we can associate a vector pair of functions $\{\omega, v\}$ to an arbitrary vector field X . If a curve $A(t)$ describes a motion of the rigid body and $V = dA/dt$ is the vector field tangent to $A(t)$, the vector pair $\{\omega, v\}$ associated with V corresponds to the instantaneous twist (screw axis) for the motion.

C. Local Parameterization of $SE(3)$

In this paper, we choose a parameterization of $SE(3)$ induced by the product structure $SO(3) \times \mathbb{R}^3$. In other words, we define a set of coordinates $\sigma_1, \sigma_2, \sigma_3, d_1, d_2, d_3$ for an arbitrary element $A = (R, d) \in SE(3)$ so that d_1, d_2, d_3 are the coordinates of d in \mathbb{R}^3 . Exponential coordinates are chosen as local parameterization of $SO(3)$. For $R \in SO(3)$ sufficiently close to the identity (i.e., excluding the points $Tr(R) = -1$ ($Tr(A) = 0$), or, equivalently, rotations through angles of π), we define the exponential coordinates $R = \exp(\hat{\sigma}) = e^{\hat{\sigma}}$, $\sigma \in \mathbb{R}^3$ where $\hat{\sigma}$ is the skew-symmetric matrix corresponding to $\sigma = [\sigma_1, \sigma_2, \sigma_3]^T$.

D. Riemannian Metrics on Lie Groups

If a smoothly varying positive-definite bilinear, symmetric form $\langle \cdot, \cdot \rangle$ is defined on the tangent space at each point on the manifold, such a form is called a Riemannian metric and the manifold is Riemannian [23], [24]. On $SE(3)$ (and on any Lie group), an inner product on the Lie algebra can be extended to a Riemannian metric over the manifold using left (or right) translation. To see this, consider the inner product of two elements $S_1, S_2 \in se(3)$ defined by

$$\langle S_1, S_2 \rangle_I = s_1^T G s_2 \quad (3)$$

where s_1 and s_2 are the 6×1 vectors of components of S_1 and S_2 with respect to some basis and G is a positive-definite matrix. If V_1 and V_2 are tangent vectors at an arbitrary group element $A \in SE(3)$ and S_1, S_2 are elements of $se(3)$ identified with V_1 and V_2 , respectively, the inner product $\langle V_1, V_2 \rangle_A$ in the tangent space $T_A SE(3)$ can be defined by

$$\langle V_1, V_2 \rangle_A = \langle A^{-1}V_1, A^{-1}V_2 \rangle_I = s_1^T G s_2. \quad (4)$$

The metric obtained in such a way is said to be left invariant [23].

III. RIEMANNIAN METRICS ON $SO(n)$ AND $SE(n)$

In this section, we will show that there is a simple way of defining a left or right invariant metric on $SO(n)$ ($SE(n)$) by introducing an appropriate constant metric in $GL^+(n)$ ($GA^+(n)$). Defining a metric (i.e., the kinetic energy) at the Lie algebra $so(n)$ (or $se(n)$) and extending it through left (right) translations will be equivalent to

inheriting the appropriate metric at each point from the ambient manifold.

A. A Metric in $GL^+(n)$

Let W be a symmetric positive-definite $n \times n$ matrix. For any $M \in GL^+(n)$ and any $X, Y \in T_M GL^+(n)$, define

$$\langle X, Y \rangle_{GL^+} = Tr(X^T Y W) = Tr(W X^T Y) = Tr(Y W X^T). \quad (5)$$

By definition, form (5) is the same at all points in $GL^+(n)$. It is clear that it is quadratic in the entries of X and Y . Let $x, y \in \mathbb{R}^{n^2}$ be the column vectors obtained by collecting all the elements of X and Y row by row. Then,

$$\langle X, Y \rangle_{GL^+} = x^T \bar{W} y$$

where

$$\bar{W} = \text{diag}(W^T, W^T, \dots, W^T), \quad \bar{W} \in \mathbb{R}^{n^2 \times n^2}.$$

It is easy to see that \bar{W} is symmetric and positive definite if and only if W is symmetric and positive definite. Therefore, (5) is a Riemannian metric on $GL^+(n)$ when W is symmetric and positive definite. We next prove the following interesting result.

Proposition 1: The metric given by (5) defined on $GL^+(n)$ is left invariant when restricted to $SO(n)$. The restriction on $SO(n)$ is bi-invariant if $W = \alpha I$, $\alpha > 0$, I is the $n \times n$ identity matrix.

Proof: Let any $M \in GL^+(n)$ and any vectors X, Y in the tangent space at an arbitrary point of $GL^+(n)$. Then, we have

$$\langle X, Y \rangle_{GL^+} = Tr(X^T Y W)$$

and

$$\langle MX, MY \rangle_{GL^+} = Tr(X^T M^T M Y W)$$

from which we conclude that the metric¹ is invariant under left translations by elements from $SO(n)$. Therefore, when restricted to $SO(n)$, metric (5) is left invariant. For right invariance, if $R \in SO(n)$, we have

$$\langle X, Y \rangle_{GL^+} = Tr(Y W X^T)$$

and

$$\langle XR, YR \rangle_{GL^+} = Tr(Y R W R^T X^T).$$

Therefore, right invariance is guaranteed only under the condition that $R W R^T = W$, i.e., when W commutes with all the elements $R \in SO(n)$, which is easily seen to be equivalent to $W = \alpha I$. ■

Remark 1: If right invariance on $SO(n)$ is desired (and left invariance is not needed), we can define

$$\ll X, Y \gg_{GL^+} = Tr(X Y^T W) = Tr(Y^T W X) = Tr(W X Y^T).$$

A similar proof shows that the metric \ll, \gg_{GL^+} will be right invariant on $SO(n)$ for W symmetric and positive definite and bi-invariant if $W = \alpha I$.

¹We will use the subscript GL^+ whenever we refer to the metric in the ambient space $GL^+(n)$.

B. Induced Metric on $SO(3)$

Even though the following derivation can be done in the general case of an $n(n-1)/2$ -dimensional manifold $SO(n)$ in the ambient n^2 -dimensional manifold $GL^+(n)$, we will limit our discussion to the $n=3$ case to avoid new notation. Further, the results are of direct interest in $SO(3)$.

Let R be an arbitrary element in $SO(3)$. Let X, Y be two vectors from $T_R SO(3)$ and $R_x(t), R_y(t)$ the corresponding local flows so that

$$X = \dot{R}_x(t) \quad Y = \dot{R}_y(t) \quad R_x(t) = R_y(t) = R.$$

The metric inherited from $GL^+(3)$ can be written as

$$\begin{aligned} \langle X, Y \rangle_{SO} &= \langle X, Y \rangle_{GL^+} \\ &= \text{Tr} \left(\dot{R}_x^T(t) \dot{R}_y(t) W \right) \\ &= \text{Tr} \left(\dot{R}_x^T(t) R R^T \dot{R}_y(t) W \right) \\ &= \text{Tr} \left(\hat{\omega}_x^T \hat{\omega}_y W \right) \end{aligned}$$

where $\hat{\omega}_x = R_x(t)^T \dot{R}_x(t)$ and $\hat{\omega}_y = R_y(t)^T \dot{R}_y(t)$ are the corresponding twists from the Lie algebra $so(3)$. If we write the above relation using the vector form of the twists, some elementary algebra leads to

$$\langle X, Y \rangle_{SO} = \omega_x^T G \omega_y \quad (6)$$

where

$$G = \text{Tr}(W) I_3 - W \quad (7)$$

is the matrix of the metric on $SO(3)$ as defined by (3). A different but equivalent way of arriving at the expression of G as in (7) would be defining the metric in $so(3)$ (i.e., at identity of $SO(3)$) as being the one inherited from $T_I GL^+(3)$: $g_{ij} = \text{Tr} (L_i^{\circ T} L_j^{\circ} W)$, $i, j = 1, 2, 3$ ($L_1^{\circ}, L_2^{\circ}, L_3^{\circ}$ is the basis in $so(3)$). Left translating this metric throughout the manifold is equivalent to inheriting the metric at each three-dimensional tangent space of $SO(3)$ from the corresponding nine-dimensional tangent space of $GL^+(3)$.

Proposition 2: The metric W on $GL^+(3)$ and the induced metric G on $SO(3)$ share the following properties.

- G is symmetric if and only if W is symmetric.
- If W is positive definite, then G is positive definite.
- If G is positive definite, then W is positive definite if and only if the eigenvalues of G satisfy the triangle inequality.

Proof: The first part follows immediately from (7). For the second part, we can use (7) to prove that the eigenvalues μ_i of G are given in terms of the eigenvalues λ_i of W by

$$\begin{aligned} \mu_1 &= \lambda_2 + \lambda_3 \\ \mu_2 &= \lambda_1 + \lambda_3 \\ \mu_3 &= \lambda_1 + \lambda_2. \end{aligned} \quad (8)$$

Because W is positive definite, it follows that $\lambda_i > 0$ which implies $\mu_i > 0$, i.e., G is positive definite. For the third part, from (8) we have

$$\begin{aligned} \lambda_1 &= \frac{\mu_2 + \mu_3 - \mu_1}{2} \\ \lambda_2 &= \frac{\mu_1 + \mu_3 - \mu_2}{2} \\ \lambda_3 &= \frac{\mu_1 + \mu_2 - \mu_3}{2}. \end{aligned} \quad (9)$$

If μ_i satisfy the triangle inequality, λ_i are positive and the claim is proved. ■

Remark 2: In the particular case when $W = \alpha I$, $\alpha > 0$, from (7), we have $G = 2\alpha I$, which is the standard bi-invariant metric on $SO(3)$. This is consistent with the second assertion in *Proposition 1*. For $\alpha = 1$, metric (5) induces the well-known Frobenius matrix norm on $GL^+(3)$ [25].

Remark 3: The quadratic form $\omega^T G \omega$ associated with metric (6) can be interpreted as the (rotational) kinetic energy. Consequently, $2G$ can be thought of as the inertia matrix of a rigid body with respect to a certain choice of the body frame $\{M\}$. The triangle inequality restriction from *Proposition 2* therefore simply states that the principal moments of inertia of a rigid body satisfy the triangle inequality, which, by definition, is true for any rigid body. Therefore, for an arbitrarily shaped rigid body with inertia matrix $2G$, we can formulate a (positive definite) metric (5) in the ambient manifold $GL^+(3)$ with matrix

$$W = \frac{1}{2} \text{Tr}(G) I_3 - G. \quad (10)$$

Thus, (10) gives us a formula for constructing an ambient metric space that is compatible with the given metric structure of $SO(3)$.

C. A Metric in $GA^+(n)$

Let

$$\tilde{W} = \begin{bmatrix} W & a \\ a^T & w \end{bmatrix} \quad (11)$$

be a symmetric positive-definite $(n+1) \times (n+1)$ matrix, where W is the matrix of metric (5), $a \in \mathbb{R}^n$, and $w \in \mathbb{R}$. Let X and Y be two vectors from the tangent space at an arbitrary point of $GA^+(n)$ (X and Y are $(n+1) \times (n+1)$ matrices with all entries of the last row equal to zero). Similar to Section III-A, a quadratic form

$$\langle X, Y \rangle_{GA^+} = \text{Tr}(X^T Y \tilde{W}) \quad (12)$$

is symmetric and positive definite if and only if \tilde{W} is symmetric and positive definite.

D. Induced Metric in $SE(3)$

We can get a left invariant metric on $SE(n)$ by letting $SE(n)$ inherit the metric $\langle \cdot \rangle_{GA^+}$ given by (12) from $GA^+(n)$. To derive the induced metric in $SE(3)$ we follow the same procedure as in Section III-B for the particular case of $n=3$.

Let A be an arbitrary element from $SE(3)$. Let X, Y be two vectors from $T_A SE(3)$ and $A_x(t), A_y(t)$ the corresponding local flows so that

$$X = \dot{A}_x(t) \quad Y = \dot{A}_y(t) \quad A_x(t) = A_y(t) = A.$$

Let

$$A_i(t) = \begin{bmatrix} R_i(t) & d_i(t) \\ 0 & 1 \end{bmatrix}, \quad i \in \{x, y\}$$

and the corresponding twists at time t

$$S_i = A_i^{-1}(t)\dot{A}_i(t) = \begin{bmatrix} \hat{\omega}_i & v_i \\ 0 & 0 \end{bmatrix}, \quad i \in \{x, y\}.$$

The metric inherited from $GA^+(3)$ can be written as

$$\begin{aligned} \langle X, Y \rangle_{SE} &= \langle X, Y \rangle_{GA^+} \\ &= Tr \left(\dot{A}_x^T(t) \dot{A}_y(t) \tilde{W} \right) \\ &= Tr \left(S_x^T A^T A S_y \tilde{W} \right). \end{aligned}$$

Now, using the orthogonality of the rotational part of A and the special form of the twist matrices, a straightforward calculation leads to the result

$$\begin{aligned} \langle X, Y \rangle_{SE} &= Tr \left(S_x^T S_y \tilde{W} \right) \\ &= Tr \left(\hat{\omega}_x^T \hat{\omega}_y W \right) + Tr \left(\hat{\omega}_x^T v_y a^T \right) \\ &\quad + v_x^T \hat{\omega}_y a + v_x^T v_y w. \end{aligned}$$

Keeping the notation from Section III-B, if G is the matrix of the metric in $SO(3)$ induced by $GL^+(3)$, then

$$\begin{aligned} \langle X, Y \rangle_{SE} &= [\omega_x^T \quad v_x^T] \tilde{G} \begin{bmatrix} \omega_y \\ v_y \end{bmatrix} \\ \tilde{G} &= \begin{bmatrix} G & \hat{a} \\ -\hat{a} & wI_3 \end{bmatrix} \end{aligned} \quad (13)$$

and G is given by (7).

Remark 4: The metric given by (13) is left invariant since the matrix \tilde{G} of this metric in the left invariant basis vector field is constant.

Remark 5: If \tilde{W} is symmetric and positive definite, then \tilde{G} given by (13) is symmetric and positive definite.

Remark 6: The quadratic form $s^T \tilde{G} s$'s associated with metric (13) can be interpreted as being the kinetic energy of a moving (rotating and translating) rigid body, where w is twice the mass m of the rigid body. If the body fixed frame $\{M\}$ is placed at the centroid of the body, then $a = 0$. Moreover, if $\{M\}$ is aligned with the principal axes of the body, then $G = (1/2)H$, where H is the diagonal inertia matrix of the body. In the most general case, when the frame $\{M\}$ is displaced by some (R_0, d_0) from the centroid and the orientation parallel with the principal axes, we have [16]

$$G = R_0^T H R_0 - m R_0^T \hat{d}_0 R_0, \quad a = -m R_0 d_0.$$

IV. PROJECTION ON $SO(n)$

We can use the norm induced by metric (5) to define the distance between elements in $GL^+(3)$. Using this distance, for a given $M \in GL^+(3)$, we define the projection of M on $SO(3)$ as being the closest $R \in SO(3)$ with respect to metric (5).

The solution of the projection problem is derived for the general case of $GL^+(n)$ and is based on the following lemma (a related treatment can be found in [26]).

Lemma 1: Let $M \in GL^+(n)$ and $M = U\Sigma V^T$ its singular value decomposition. Then, $R = UV^T$ is the solution to the maximization problem

$$\max_{R \in SO(n)} Tr(M^T R).$$

Proof: The proof is based on the Cauchy–Schwartz inequality and is omitted. The interested reader is referred to [27] for a detailed proof of an almost similar problem. The uniqueness of the solution is also guaranteed. ■

The following proposition is the main result of this section.

Proposition 3: Let $M \in GL^+(n)$ and U, Σ, V the singular value decomposition of MW (i.e., $MW = U\Sigma V^T$). Then, the projection of M on $SO(n)$ with respect to metric (5) is given by $R = UV^T$.

Proof: The problem to be solved is a minimization problem

$$\min_{R \in SO(n)} \|M - R\|_{GL^+}^2.$$

We have

$$\begin{aligned} \|M - R\|_{GL^+}^2 &= \langle M - R, M - R \rangle_{GL^+} \\ &= Tr[(M - R)^T (M - R)W] \\ &= Tr(M^T MW - M^T RW - R^T MW + R^T RW). \end{aligned}$$

Note that $Tr(R^T MW) = Tr(WM^T R) = Tr(M^T RW)$ and the quantities $M^T MW$ and $R^T RW = W$ are constant and, therefore, does not affect the optimization. Therefore, the problem to be solved becomes

$$\max_{R \in SO(n)} Tr(WM^T R).$$

With $MW = U\Sigma V^T$, according to Lemma 1, the solution to the above problem is $R = UV^T$. ■

Remark 7: Let \mathbf{P} denote the $n(n+1)/2$ -dimensional subset of symmetric matrices of $GL^+(n)$.

- For the particular case when $W = I_n$, \mathbf{P} describes the set of all matrices that project to identity in metric (5)—the fiber at identity. Note that the dimensions agree $SO(n)$ is $n(n-1)/2$ dimensional, the fiber \mathbf{P} is $n(n+1)/2$ dimensional; the sum gives n^2 , which is the dimension of the ambient $GL^+(n)$. Also, in this case, given $R \in SO(n)$, the set that projects to R (fiber at R) is the left translated \mathbf{P} : $R\mathbf{P}$.
- In the general case, the set of matrices that project to some given $R \in SO(3)$ in metric (5) is $R\mathbf{P}W^{-1}$.

Remark 8: It is easy to see that the distance between M and R in metric (5) is given by $Tr(W^{-1}V\Sigma^2V^T) + Tr(W) -$

$2Tr(\Sigma)$. For the particular case when $W = I_3$, the distance becomes $\sum_{i=1}^n (\sigma_i - 1)^2$, which is the standard way of describing how “far” a matrix is from being orthogonal.

The question we might ask is what happens with the solution to the projection problem when the manifold $GL^+(n)$ is acted upon by the group $SO(n)$. The answer is given below.

Proposition 4: The solution to the projection problem on $SO(n)$ is left invariant under actions of elements from $SO(n)$. If $W = \alpha I_3$, the solution is bi-invariant.

Proof: Let $M \in GL^+(n)$, $MW = U\Sigma V^T$ and the corresponding projection $R \in SO(n)$, $R = UV^T$. Consider the action of any $L \in SO(n)$ on M : $\bar{M} = LM$. Then, a singular value decomposition (SVD) for $\bar{M}W$ yields $\bar{M}W = (LU)\Sigma V^T$. Then, by *Proposition 3*, the projection of \bar{M} on $SO(3)$ is $\bar{R} = LUV^T = LR$, which proves left invariance. However, right translation of M by $L \in SO(3)$ gives $\bar{M} = ML$ and $\bar{M}W = U\Sigma V^T W^{-1}LW$. The translated projection is $UV^T L$. Right invariance is therefore guaranteed if $W^{-1}LW = L$, i.e., W commutes with arbitrary elements from $SO(n)$. This is true only if $W = \alpha I$. ■

Remark 9: For the case $W = I$, it is worthwhile to note that other projection methods do not exhibit bi-invariance. For instance, it is customary to find the projection $R \in SO(n)$ by applying a Gram–Schmidt procedure (QR decomposition). In this case, it is easy to see that the solution is left invariant, but, in general, it is not right invariant.

V. PROJECTION ON $SE(n)$

Similar to Section IV, if a metric of the form (12) is defined on $GA^+(n)$ with the matrix of the metric given by (11), we can find the corresponding projection on $SE(n)$. We consider the case $a = 0$, which corresponds to a body frame $\{M\}$ fixed at the centroid of the body.

Proposition 5: Let $B \in GA^+(n)$ with the following block partition:

$$B = \begin{bmatrix} B_1 & B_2 \\ 0 & 1 \end{bmatrix}, \quad B_1 \in GL^+(n); \quad B_2 \in \mathbb{R}^n$$

and U, Σ, V be the singular value decomposition of $B_1 W$. Then, the projection of B on $SE(n)$ is given by

$$A = \begin{bmatrix} UV^T & B_2 \\ 0 & 1 \end{bmatrix} \in SE(n).$$

Proof: Let

$$A = \begin{bmatrix} R & d \\ 0 & 1 \end{bmatrix}, \quad R \in SO(n); \quad d \in \mathbb{R}^n.$$

The problem to be solved can be formulated as follows:

$$\min_{A \in SE(n)} \|B - A\|_{GA^+}^2.$$

We have

$$\begin{aligned} \|B - A\|_{GA^+}^2 &= Tr[(B - A)^T (B - A) \tilde{W}] \\ &= Tr(B^T B \tilde{W}) - 2Tr(B^T A \tilde{W}) + Tr(A^T A \tilde{W}). \end{aligned}$$

The quantity $B^T B \tilde{W}$ is not involved in the optimization. Therefore, the problem becomes

$$\min_{A \in SE(n)} [-2Tr(B^T A \tilde{W}) + Tr(A^T A \tilde{W})].$$

Since

$$Tr(A^T A \tilde{W}) = Tr(W) + (d^T d + 1)w$$

and

$$Tr(B^T A \tilde{W}) = Tr(B_1^T R W) + (B_2^T d + 1)w$$

we can separate the initial problem into two subproblems

$$1) \max_{R \in SO(n)} Tr(B_1^T R W) = \max_{R \in SO(n)} Tr(W B_1^T R)$$

and

$$2) \min_{d \in \mathbb{R}^n} [-2B_2^T d + d^T d].$$

From *Lemma 1*, the solution to the first subproblem is $R = UV^T$. For the second subproblem, note that $d = B_2$ is the only critical point of the scalar function $-2B_2^T d + d^T d$. It is easy to verify that the Hessian at this point is $2I$, which is positive definite. Therefore, the solution is $d = B_2$ which concludes the proof. ■

Similar to the $SO(n)$ case, the projection on $SE(n)$ exhibits several interesting invariance properties.

Proposition 6: The solution to the projection problem on $SE(n)$ is left invariant under actions of elements from $SE(n)$. In the special case when $W = \alpha I$, the projection is bi-invariant under rotations.

Proof: Let

$$B = \begin{bmatrix} B_1 & B_2 \\ 0 & 1 \end{bmatrix} \in GA^+(n)$$

and define A, U, Σ, V such that

$$B_1 W = U\Sigma V^T \quad A = \begin{bmatrix} UV^T & B_2 \\ 0 & 1 \end{bmatrix} \in SE(n).$$

Let

$$Q = \begin{bmatrix} R & d \\ 0 & 1 \end{bmatrix}$$

be an arbitrary element from $SE(n)$. Under left actions of Q , the solution pair becomes

$$\begin{aligned} QB &= \begin{bmatrix} RB_1 & RB_2 + d \\ 0 & 1 \end{bmatrix} \\ QA &= \begin{bmatrix} RUV^T & RB_2 + d \\ 0 & 1 \end{bmatrix} \end{aligned}$$

which proves left invariance of the projection. For the second part, note that the right translated solution pair is

$$\begin{aligned} BQ &= \begin{bmatrix} B_1 R & B_1 d + B_2 \\ 0 & 1 \end{bmatrix} \\ AQ &= \begin{bmatrix} UV^T R & UV^T d + B_2 \\ 0 & 1 \end{bmatrix}. \end{aligned}$$

It is easy to see that $B_1RW = U\Sigma V^T W^{-1}RW$. With $W = \alpha I$, we have $B_1RW = U\Sigma V^T R$. If only rotations ($d = 0$) are taken into consideration, right invariance is proved. A more detailed treatment of this case can be found in [21]. ■

VI. PROJECTION METHOD

Based on the results we proved so far, we can outline a method to generate an interpolating curve $A(t) \in SE(3)$, $t \in [0, 1]$ while satisfying the boundary conditions

$$A(0), A(1), \dot{A}(0), \dot{A}(1), \dots, A^{(m)}(0), A^{(m)}(1)$$

where the superscript $(\cdot)^{(m)}$ denotes the m th derivative. The projection procedure consists of two steps.

Step 1) Generate the optimal curve $B(t)$ in the ambient manifold $GA^+(3)$, which satisfies the boundary conditions.

Step 2) Project $B(t)$ from Step 1) onto $A(t) \in SE(3)$.

Due to the fact that the metric we defined on $GA^+(3)$ is the same at all points, the corresponding Christoffel symbols are all zero. Consequently, the optimal curves in the ambient manifold assume simple analytical forms. For example, geodesics are straight lines, minimum acceleration curves are cubic polynomial curves, and minimum jerk curves are fifth-order polynomial curves in $GA^+(3)$, all parameterized by time. Therefore, in Step 1), the following curve is constructed in $GA^+(3)$:

$$B(t) = B_0 + B_1 t + \dots + B_{2m-1} t^{2m-1}$$

where the coefficients B_i , $i = 1, \dots, 2m-1$ are linear functions Γ_i of the input data

$$B_i = \Gamma_i \left(A(0), A(1), \dot{A}(0), \dot{A}(1), \dots, A^{(m)}(0), A^{(m)}(1) \right).$$

Step 2) consists of an SVD decomposition weighted by the matrix W as described in *Proposition 5* to produce the curve $A(t)$.

A. Left Invariance—Independence of Inertial Frame

If the interpolating curve on $SE(3)$ is generated by solving the exact equations of the optimal motion in the Lie algebra $se(3)$, i.e., (17) for geodesics, then the resulting trajectory is invariant to displacements of the inertial frame $\{F\}$. This means that, given the optimal trajectory of the body with respect to an inertial frame [i.e., a curve on $SE(3)$], the optimal trajectory in a new displaced frame is obtained by left translation. The geometric argument for this is that left invariance of the metric, combined with the left invariance of the twists, gives invariance of the metric to changes (constant displacements) of the inertial frame.

Similarly, for the projection method outlined above, we ask if the generated motion is independent of the choice of the reference frame $\{F\}$. The answer is given in the following proposition.

Proposition 7: The projection method on $SE(3)$ is left invariant, i.e., the generated trajectories are independent of the choice of the inertial frame $\{F\}$.

Proof: Assume the inertial frame $\{F\}$ is displaced to $\{F'\}$ and the transformation matrix giving the displacement of $\{F\}$

in $\{F'\}$ is $Q \in SE(3)$. As seen from the new frame $\{F'\}$, the boundary conditions are

$$QA(0), QA(1), Q\dot{A}(0), Q\dot{A}(1), \dots, QA^{(m)}(0), QA^{(m)}(1)$$

and the interpolating curve in $GA^+(3)$ satisfying the new boundary conditions becomes

$$\bar{B}(t) = \bar{B}_0 + \bar{B}_1 t + \dots + \bar{B}_{2m-1} t^{2m-1}$$

where

$$\bar{B}_i = \Gamma_i \left(QA(0), QA(1), Q\dot{A}(0), Q\dot{A}(1), \dots, QA^{(m)}(0), QA^{(m)}(1) \right), \quad i = 1, \dots, 2m-1.$$

Since the functions Γ_i are linear, we conclude that $\bar{B}(t) = QB(t)$. Now using *Proposition 6*, the projection of $QB(t) \in GA^+(3)$ onto $SE(3)$ is simply $QA(t)$. Thus, the projection method on $SE(3)$ consisting of two steps is left invariant, i.e., the generated trajectories are invariant to displacements of the inertial frame $\{F\}$. ■

Remark 10: Due to the linearity on the boundary conditions of the curve in the ambient manifold, the first step is always bi-invariant, i.e., invariant to arbitrary displacements in both the inertial frame $\{F\}$ and the body frame $\{M\}$. The invariance properties of the overall method are, therefore, dictated by the second step. According to *Proposition 6*, the procedure is bi-invariant with respect only to rotations of $\{F\}$ in the particular case of $W = \alpha I$. In the most general case, i.e., for arbitrary choices of W , the method is left invariant to arbitrary displacements of the inertial frame.

B. Uniqueness and Smoothness of the Projection

Due to the fact that $SE(3) = SO(3) \times \mathbb{R}^3$ and the metrics that we use are product metrics, it is sufficient to answer the above questions for $SO(3)$ and the ambient $GL^+(3)$. Also, due to the left invariance of the generated trajectories, without loss of generality, we can restrict our attention to curves passing through identity. Finally, in accordance with the scope of this paper, the discussion will be limited to geodesics and minimum acceleration curves.

1) *Uniqueness:* Let us first note that even if the SVD of some matrix from $M \in GL^+(3)$: $M = U\Sigma V^T$ is not unique (it is unique up to permutations of the singular values), the product $R = UV^T$ giving the projection on $SO(3)$ is unique. Finding the projection on $SO(3)$ in the form UV^T using SVD is equivalent to determining the polar decomposition $M = QS$ (Q orthogonal, S symmetric and positive definite) with $Q = R = UV^T$, $S = V\Sigma V^T$. Also, as noted in [28], using the polar decomposition, one can find the orthogonal part Q by averaging the matrix with its inverse transpose until convergence, which can be proved to be cheaper to compute than the actual SVD of the matrix. We use SVD throughout the paper simply because there is a lot more information in SVD than in polar decomposition. For example, proof of *Lemma 1* is much simpler than the proof of a somewhat similar result given in the appendix of [28], which uses the Lagrange multiplier method to solve a constrained optimization problem. Also, the invariance properties

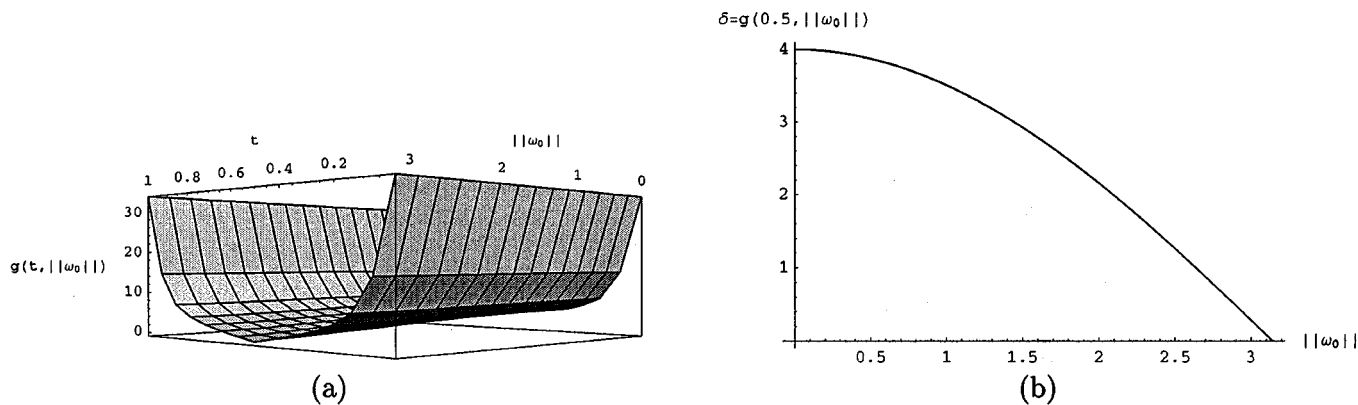

Fig. 2. Upper bounds on the end velocities on $SO(3)$ are imposed so that the interpolating cubic in the ambient manifold does not leave $GL^+(3)$.

of the projection become transparent in the SVD. Moreover, the deviation of the actual singular values of some matrix from 1 is a good measure of how far that matrix is from being orthogonal. In the actual implementation of the method, one can always use polar decomposition if calculation becomes expensive.

Also, uniqueness of the projection as in *Proposition 3* is guaranteed if MW is nonsingular [29]. Since W is positive definite, we only need to make sure that the smooth curve $M(t)$ generated in the ambient manifold do not leave $GL^+(3)$ (an element of $GL(3)$ with negative determinant will not project to a rotation but to a reflection).

Consider the following interpolant between I at $t = 0$ and $R(1) = e^{\omega_0} \in SO(3)$ at $t = 1$:

$$M(t) = I + (R(1) - I)f(t), \quad t \in [0, 1] \quad (14)$$

where $f(t)$ is a smooth function with $f(0) = 0$, $f(1) = 1$. According to [22], the singular values of $M(t)$ are given by $\{1, s(t), s(t)\}$ where

$$s(t) = \sqrt{2(1 - \cos \|\omega_0\|)f(t)^2 - 2(1 - \cos \|\omega_0\|)f(t) + 1}. \quad (15)$$

By studying the binomial under the square root, it is easy to see that $s(t) > 0$, $\forall t \in [0, 1]$ if and only if $\|\omega_0\| \neq (2k+1)\pi$, k integer. $s(t)$ can become zero if and only if $\|\omega_0\| = (2k+1)\pi$ and $f = 1/2$. Note that this condition corresponds to singular points of the exponential coordinates for $SO(3)$. Therefore, restricting the magnitude of the rotation $0 \leq \|\omega_0\| < \pi$ (which is the usual assumption when exponential coordinates are used as local parameterization of $SO(3)$ around identity) guarantees that the singular values of $M(t)$ stay positive when $t \in [0, 1]$, i.e., $M(t)$ stays in $GL^+(3)$. As a particular case for $f(t) = t$, the geodesic in $GL^+(3)$, $M(t) = I + (R(1) - I)t$, passing through identity at $t = 0$ does not leave $GL^+(3)$ if the magnitude of the rotation is less than π .

For a minimum acceleration curve, we expect the stay condition to also depend on the magnitudes of the end velocities. Explicitly, the cubic polynomial interpolating boundary conditions on $SO(3)$ given by $R(0) = I$, $\dot{R}(0)$ at $t = 0$ and $R(1)$, $\dot{R}(1)$ at $t = 1$

$$M(t) = I + \dot{R}(0)t + (-3I + 3R(1) - 2\dot{R}(0) - \dot{R}(1))t^2 + (2I - 2R(1) + \dot{R}(0) + \dot{R}(1))t^3 \quad (16)$$

can be rewritten as $M(t) = M_1(t) + M_2(t)$ where

$$M_1(t) = I + (R(1) - I)f(t), \quad f(t) = 3t^2 - 2t^3 \\ M_2(t) = (t - 2t^2 + t^3)\dot{R}(0) + (-t^2 + t^3)\dot{R}(1).$$

Let $\bar{\sigma}(\cdot)$ and $\underline{\sigma}(\cdot)$ denote the largest and smallest singular values of some matrix. Then,

$$M(t) > 0 \Leftrightarrow \underline{\sigma}(M(t)) > 0, \quad t \in [0, 1].$$

Using

$$\underline{\sigma}(M(t)) \geq \underline{\sigma}(M_1(t)) - \bar{\sigma}(M_2(t))$$

finding a lower bound for $\underline{\sigma}(M(t))$ reduces to finding a lower bound for $\underline{\sigma}(M_1(t))$ and an upper bound for $\bar{\sigma}(M_2(t))$.

$M_1(t)$ is of the form (14), and, therefore, it has singular values at $\{1, s(t), s(t)\}$, where $s(t)$ is given by (15). It is easy to see that for $f(t) = 3t^2 - 2t^3$, $s(t) < 1$, and, therefore, $\underline{\sigma}(M_1(t)) = s(t)$.

Now assume that the end velocities are upper bounded by $\delta > 0$ in 2-norm, i.e., $\bar{\sigma}(\dot{R}(0)), \bar{\sigma}(\dot{R}(1)) < \delta$. We have

$$\bar{\sigma}(M_2(t)) \leq \bar{\sigma}((t - 2t^2 + t^3)\dot{R}(0) + (-t^2 + t^3)\dot{R}(1)) < (t - t^2)\delta.$$

Then, a sufficient condition for $\underline{\sigma}(M(t)) > 0$ is

$$\delta = g(t, \|\omega_0\|) := \frac{s(t)}{t - t^2}.$$

A plot of $g(t, \|\omega_0\|)$ is presented in Fig. 2(a) for $t \in [0, 1]$ and $\|\omega_0\| \in [0, \pi]$. It can be seen (even though this can be proved rigorously by taking derivatives of $g(t, \|\omega_0\|)$) that the minimum value of the function is always attained at $t = 0.5$, for all the values of $\|\omega_0\| \in [0, \pi]$. We conclude that a sufficient condition for a cubic interpolant of the form (16) to remain in $GL^+(3)$ for $t \in [0, 1]$ can be expressed in terms of upper bounds on the end velocities as $\delta < g(0.5, \|\omega_0\|)$. To illustrate the magnitudes of the allowed velocities, a plot of $g(0.5, \|\omega_0\|)$ is given in Fig. 2(b) for a $\|\omega_0\| \in [0, \pi]$. As expected, the upper bound on end velocities becomes more restrictive with the increase on the rotational displacement.

Remark 11: The bound on the amount of rotation $\theta < \pi$ is not really restrictive, since rotations θ larger than π can always

be achieved by rotating $2\pi - \theta$ around the same axis but on opposite direction.

2) *Smoothness*: Since the SVD (or polar decomposition) is a smooth operation, and provided that the smooth curve generated in the ambient manifold does not leave $GL^+(3)$ (this guarantees unique projections), the projected curve on $SO(3)$ is smooth.

Singularities might occur due to the projection from $GL^+(3)$ (a nine-dimensional manifold) to $SO(3)$ (a three-dimensional manifold). Specifically, the projected curve can have a cusp point when the tangent to the curve in the ambient space is also tangent to the fiber of the projection. Also, a curve that meets a fiber in two places will project to a curve with a self intersection. However, provided that the curve in $SO(3)$ is smooth in time, since the goal of this method is motion generation for robots, cusps and self intersection points are allowed. A cusp on a smooth curve on $SO(3)$ will physically correspond to a situation when the angular velocity of the body smoothly decreases to 0 and then starts increasing. This situation mostly occurs in motion generation for nonholonomic robots. A self intersection point corresponds to the body attaining the same pose at two different times.

C. Closeness of Projected Curves to Optimal Interpolating Trajectories

It can be proved [22] that in the Euclidean case ($G = \alpha I_3$, $W = (\alpha/2)I_3$ in (5) and (6)), the geodesic $R(t) \in SO(3)$ interpolating between I (at $t = 0$) and $R_2 = e^{\hat{\omega}_0}$ (at $t = 1$)

$$R(t) = e^{\hat{\omega}_0 t}$$

follows the same path as the projection $R^\perp(t)$ of the corresponding line

$$M(t) = I + (R_2 - I)t, \quad t \in [0, 1]$$

but with a different parameterization, i.e.,

$$M(t) = U(t)\Sigma(t)V^T(t) \Rightarrow R^\perp(t) = U(t)V^T(t) = e^{\hat{\omega}_0 \theta(t)}$$

$$\theta(t) = \frac{1}{\|\omega_0\|} \text{atan2}(1 - t + t \cos \|\omega_0\|, t \sin \|\omega_0\|).$$

By inverting the function θ , one can also find the parameterization of the line from $GL^+(3)$, which will project to the exact geodesic on $SO(3)$.

For non-Euclidean metrics $G \neq \alpha I_3$ and higher order polynomial curves, we cannot establish how close the projected curves are to the optimal ones simply because there is no analytical, closed form expression for the latter. However, numerical simulations like the ones included in Section VII give satisfactory results.

VII. GENERATING SMOOTH CURVES ON $SO(3)$ AND $SE(3)$

We will first focus on $SO(3)$. Due to the product structure of both $SE(3) = SO(3) \times \mathbb{R}^3$ and the metric $\langle \cdot, \cdot \rangle_{SE}$ for $a = 0$, all the results are straightforward to extend to $SE(3)$.

A. Geodesics on $SO(3)$

The problem we approach is generating a geodesic $R(t)$ between given end positions $R_1 = R(0)$ and $R_2 = R(1)$ on

$SO(3)$. Without loss of generality, we will assume $R_1 = I$. Indeed, a geodesic between two arbitrary points R_1 and R_2 is the geodesic between I and $R_1^{-1}R_2$ left translated by R_1 [13], [16].

The differential equations to be satisfied by the geodesics on $SO(3)$ equipped with metric G are given by (2) together with the celebrated Euler's equations:

$$G\dot{\omega}(t) + \omega(t) \times (G\omega(t)) = 0. \quad (17)$$

A nice derivation of (17) using differential geometric tools is given in [16]. Even though (17) has an explicit solution in terms of Jacobi elliptic functions [30], there is no closed form expression for the interpolating curve on the base manifold $SO(3)$, except for the special case when $G = \alpha I$. In the general case, one must solve the differential system given by (2) and (17) numerically. A local parameterization of $SO(3)$ should be chosen and three first-order differential equations relating ω to the derivatives of the parameters augment the system. Here, exponential coordinates $\sigma_1, \sigma_2, \sigma_3$ are used to parameterize $SO(3)$. We solve a system of six first-order nonlinear coupled differential equations with three boundary conditions at each end. We obtain the numerical solution by using a relaxation method [31].

In our projection method described above, we solve the problem in $GL^+(3)$, while keeping the proper boundary conditions for $SO(3)$. Geodesics are found in $GL^+(3)$ and eventually projected back onto $SO(3)$.

The geodesic in $GL^+(3)$ is

$$M(t) = R_0 + (R_1 - R_0)t, \quad t \in [0, 1].$$

The projection onto $SO(3)$ using the metric W is given by:

$$M(t)W = U(t)\Sigma(t)V(t)^T,$$

$$R(t) = U(t)V(t)^T, \quad W = \frac{1}{2}Tr(G)I_3 - G. \quad (18)$$

Illustrative examples are shown in Figs. 3 and 4, where end positions on $SO(3)$ are given in exponential coordinates. In all the examples, the initial condition is $\sigma(0) = [0, 0, 0]^T$, which corresponds to the body frame $\{M\}$ being parallel with the inertial frame $\{F\}$ at $t = 0$. Both Figs. 3(a) and 4(a) correspond to final condition $\sigma(1) = [\pi/10, \pi/10, \pi/10]^T$ (i.e., a rotation of $\pi\sqrt{3}/10$ about the unit vector $[1/\sqrt{3}, 1/\sqrt{3}, 1/\sqrt{3}]^T$), while Figs. 3(b) and 4(b) describe the final condition $\sigma(1) = [\pi/6, \pi/3, \pi/2]^T$ (i.e., a rotation of $\pi\sqrt{14}/6$ about the unit vector $[1/\sqrt{14}, 2/\sqrt{14}, 3/\sqrt{14}]^T$). In other words, Figs. 3(a) and 4(a) represent a small (compared with π) rotation, while Figs. 3(b) and 4(b) are a rotation approximately four times that in Figs. 3(a) and 4(a).

In Fig. 3, $G = \alpha I$ and the geodesic passing through identity on $SO(3)$ is a uniformly parameterized line through the origin in exponential coordinates. Also, as proved in [22], the projected geodesic follows the same path but with a different parameterization. When the displacement is small, as in Fig. 3(a), the parameterizations of the curves obtained by relaxation and projection are almost the same. The difference in parameterization is more pronounced in Fig. 3(b), when the excursion is large.

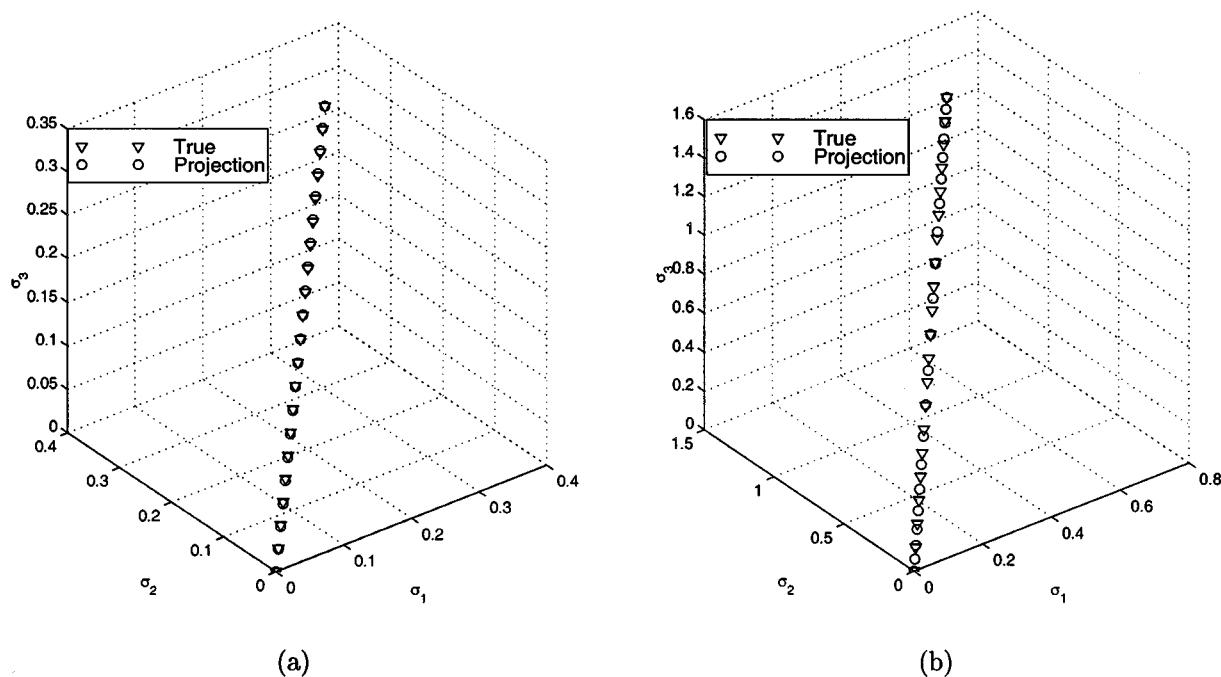

Fig. 3. Geodesics on $SO(3)$ for an isotropic metric $G = \text{diag}\{3, 3, 3\}$ drawn in exponential coordinates. (a) $\sigma(1) = [\pi/10, \pi/10, \pi/10]^T$. (b) $\sigma(1) = [\pi/6, \pi/3, \pi/2]^T$.

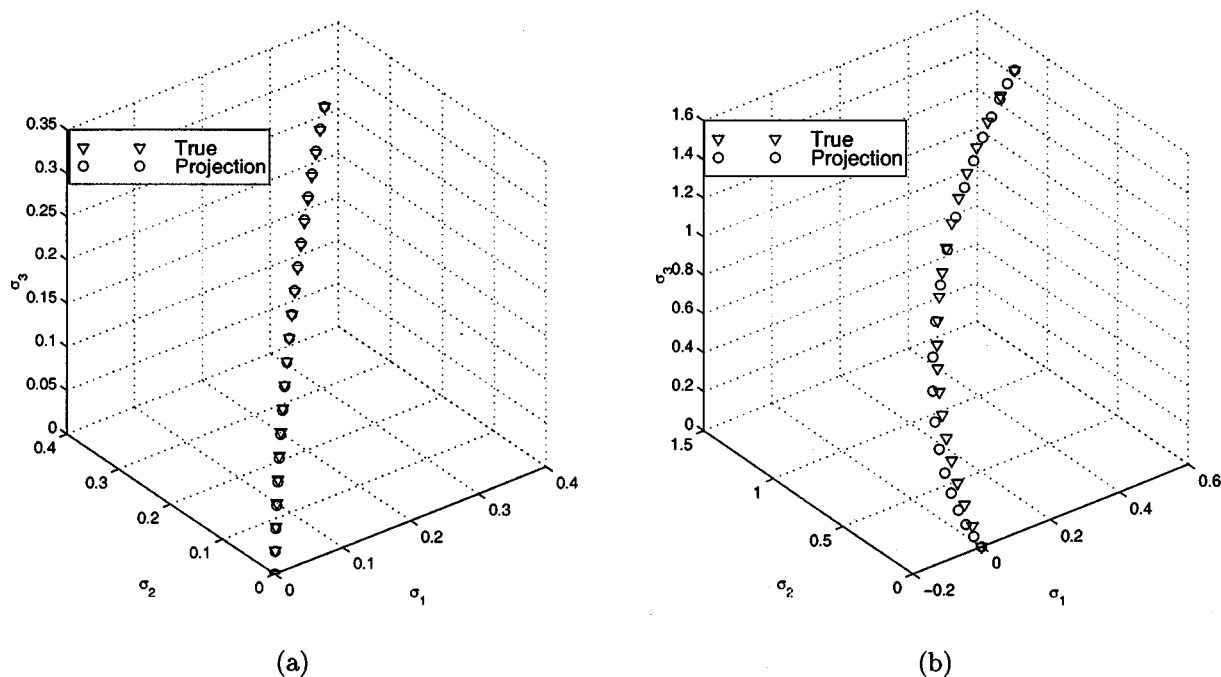

Fig. 4. Geodesics on $SO(3)$ for metric $G = \text{diag}\{10, 10, 3\}$ drawn in exponential coordinates. (a) $\sigma(1) = [\pi/10, \pi/10, \pi/10]^T$. (b) $\sigma(1) = [\pi/6, \pi/3, \pi/2]^T$.

In Fig. 4, $G \neq \alpha I$ and the geodesics in exponential coordinates are not straight lines anymore. Also, the geodesic and the projected curve follow different paths. Again, the difference between the geodesic obtained by relaxation and the projected curve is more noticeable for larger displacements, as in Fig. 4(b).

B. Minimum Acceleration Curves on $SO(3)$

The differential equations to be satisfied by minimum acceleration curves on $SO(3)$ with metric G are known only for the case $G = \alpha I$ [16]. In the general case, the calculation of the symmetric connection corresponding to G is very involved and almost intractable. The projection method can still be used to generate

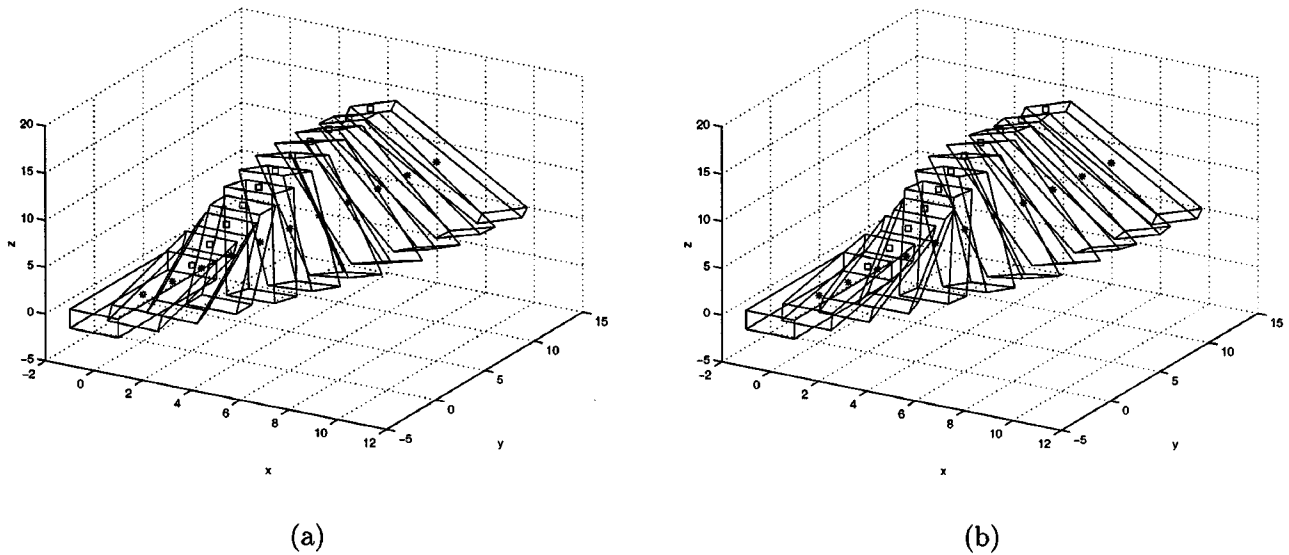

Fig. 5. Geodesic motion for a parallelepipedic body. (a) Relaxation method. (b) Projection method.

smooth interpolating motion, even though we do not have a way of comparing the generated trajectory with the optimal one.

In what follows, the time interval will be $t \in [0, 1]$ and the boundary conditions $R(0)$, $R(1)$, $\dot{R}(0)$, $\dot{R}(1)$ are assumed to be specified. The minimum acceleration curve in $GL^+(3)$ with a constant metric $\langle \cdot, \cdot \rangle_{GL^+}$ is a cubic given by

$$M(t) = M_0 + M_1 t + M_2 t^2 + M_3 t^3$$

where $M_0, M_1, M_2, M_3 \in GL^+(3)$ are

$$\begin{aligned} M_0 &= R(0) \\ M_1 &= \dot{R}(0) \\ M_2 &= -3R(0) + 3R(1) - 2\dot{R}(0) - \dot{R}(1) \\ M_3 &= 2R(0) - 2R(1) + \dot{R}(0) + \dot{R}(1). \end{aligned}$$

Now the curve on $SO(3)$ is obtained by projecting $M(t)$ onto $SO(3)$ using (18). Several examples are shown in our previous work [22].

C. Generation of Rigid Body Motion

Since we know how to generate near optimal curves in $SO(3)$, the extension to $SE(3)$ is simply adding the well-known optimal curves from \mathbb{R}^3 . In the example considered in Fig. 5, a homogeneous parallelepiped is assumed to move (rotate and translate) in free space. We assume that the body frame $\{M\}$ is placed at the center of mass and aligned with the principal axes of the body. Let a , b , and c be the lengths of the body along its x , y , and z axes, respectively, and m the mass of the body. The G matrix of metric $\langle \cdot, \cdot \rangle_{SO}$ is given by

$$G = \begin{bmatrix} \frac{m}{24}(b^2 + c^2) & 0 & 0 \\ 0 & \frac{m}{24}(a^2 + c^2) & 0 \\ 0 & 0 & \frac{m}{24}(a^2 + b^2) \end{bmatrix}$$

The following boundary conditions were considered:

$$\begin{aligned} \sigma(0) &= [0 \ 0 \ 0]^T \\ \sigma(1) &= \left[\frac{\pi}{6} \ \frac{\pi}{3} \ \frac{\pi}{2} \right]^T \\ d(0) &= [0 \ 0 \ 0]^T \\ d(1) &= [8 \ 10 \ 12]^T. \end{aligned}$$

The geodesics for a parallelepiped with $a = c = 2$, $b = 10$, and $m = 12$ are given in Fig. 5. For visualization, a small square is drawn on one of its faces and the center of the parallelepiped is shown starred. For this case,

$$G = \begin{bmatrix} 52 & 0 & 0 \\ 0 & 4 & 0 \\ 0 & 0 & 52 \end{bmatrix}.$$

As seen in Fig. 5, even though the total displacement between the initial and final positions on $SO(3)$ is large (rotation angle of $\pi\sqrt{14}/6$), there is no noticeable difference between the true and the projected motions.

D. Computational Efficiency

It is not difficult to see that, from a computational point of view, it is less expensive to generate interpolating motion using the projection method as opposed to the relaxation method. Recall that the complexity of the SVD of a $n \times n$ matrix is of order n^3 [25]. If M is the number of uniformly distributed points in $[0, 1]$, then the number of flops required by the projection method in $GL^+(n)$ is of order $O(n^3 M)$.

The relaxation method for generating solution at M mesh points of a system of N differential equations with two boundary conditions implies solving a $MN \times MN$ linear system in the corrections iteratively until the method relaxes to the solution (corrections converge to zero) [31]. Gaussian elimination, whose complexity is cubic, is used to solve the

linear systems. Therefore, the number of flops required in the relaxation method is of order $O(M^3N^3)$.

Consider the problem of generating geodesics on $SO(n)$. Here $N = n(n-1)$. The projection method involves $O(n^3M)$ flops while the relaxation method has complexity of the order $O(n^6M^3)$. For $M = 100$, as we used in this paper, the generation of geodesics on $SO(3)$ ($n = 3$) requires millions of flops by the relaxation method, while requiring only thousands by the projection method.

VIII. CONCLUSION

This paper develops a method for generating smooth trajectories for a moving rigid body with specified conditions at end points. Our method involves two key steps: 1) the generation of optimal trajectories in $GA^+(n)$; and 2) the projection of the trajectories from $GA^+(n)$ to $SE(n)$. The overall procedure is invariant with respect to both the local coordinates on the manifold, and the choice of the inertial frame. The benefits of the method are three-fold. First, it is possible to apply any of the variety of well-known efficient techniques to generate optimal curves on $GA^+(n)$ [1], [3]. Second, the method yields nearly optimal solutions for general choices of Riemannian metrics on $SE(3)$. For example, we can incorporate the dynamics of arbitrarily shaped rigid bodies. Third, from a computational point of view, the method we propose is less expensive than traditional methods. We presented the application of the basic ideas to a motion generation problem with specified boundary conditions.

REFERENCES

- [1] G. E. Farin, *Curves and Surfaces for Computer Aided Geometric Design: A Practical Guide*, 3rd ed. Boston, MA: Academic, 1992.
- [2] J. Hoschek and D. Lasser, *Fundamentals of Computer Aided Geometric Design*. Wellesley, MA: A. K. Peters, 1993.
- [3] J. Gallier, *Curves and Surfaces in Geometric Modeling—Theory and Algorithms*. San Francisco, CA: Morgan Kaufmann, 2000.
- [4] K. Shoemake, "Animating rotation with quaternion curves," *ACM SIGGRAPH*, vol. 19, no. 3, pp. 245–254, 1985.
- [5] Q. J. Ge and B. Ravani, "Geometric construction of Bezier motion," *ASME J. Mech. Des.*, vol. 116, no. 3, pp. 749–755, 1994.
- [6] F. C. Park and B. Ravani, "Bezier curves on Riemannian manifolds and Lie groups with kinematics applications," *ASME J. Mech. Des.*, vol. 117, no. 1, pp. 36–40, 1995.
- [7] Q. J. Ge and B. Ravani, "Computer aided geometric design of motion interpolants," *ASME J. Mech. Des.*, vol. 116, no. 1, pp. 756–762, 1994.
- [8] B. Jüttler, "Visualization of moving objects using dual quaternion curves," *Comput. Graph.*, vol. 18, no. 3, pp. 315–326, 1994.
- [9] L. Srinivasan and Q. J. Ge, "Fine tuning of rational B-spline motions," *ASME J. Mech. Des.*, vol. 120, no. 1, pp. 46–51, 1998.
- [10] B. Jüttler and M. Wagner, "Computer aided design with rational B-spline motions," *ASME J. Mech. Des.*, vol. 118, no. 2, pp. 193–201, 1996.
- [11] F. C. Park and I. G. Kang, "Cubic interpolation on the rotation group using Cayley parameters," in *Proc. ASME 24th Biennial Mechanisms Conf.*, Irvine, CA, 1996.
- [12] A. Marthinsen, "Interpolation in Lie groups and homogeneous spaces," *SIAM J. Numer. Anal.*, vol. 37, no. 1, pp. 269–285, 1999.
- [13] L. Noakes, G. Heinzinger, and B. Paden, "Cubic splines on curved spaces," *IMA J. Math. Control Inform.*, vol. 6, pp. 465–473, 1989.
- [14] P. Crouch and F. S. Leite, "The dynamic interpolatin problem: On Riemannian manifolds, Lie groups, and symmetric spaces," *J. Dynam. Control Syst.*, vol. 1, no. 2, pp. 177–202, 1995.
- [15] M. Camarinha, F. S. Leite, and P. Crouch, "Splines of class c^k on non-Euclidean spaces," *IMA J. Math. Control Inform.*, vol. 12, no. 4, pp. 399–410, 1995.

- [16] M. Žefran, V. Kumar, and C. Croke, "On the generation of smooth three-dimensional rigid body motions," *IEEE Trans. Robot. Automat.*, vol. 14, pp. 579–589, Aug. 1995.
- [17] M. Žefran and V. Kumar, "Interpolation schemes for rigid body motions," *Comput. Aided Des.*, vol. 30, no. 3, pp. 179–189, 1998.
- [18] A. Edelman, T. A. Arias, and S. T. Smith, "The geometry of algorithms with orthogonality constraints," *SIAM J. Matrix Anal. Appl.*, vol. 20, no. 2, pp. 303–353, 1998.
- [19] J. Cheeger and D. G. Ebin, *Comparison Theorems in Riemannian Geometry*. Amsterdam, The Netherlands: North-Holland, 1975.
- [20] F. C. Park and R. W. Brockett, "Kinematic dexterity of robotic mechanisms," *Int. J. Robot. Res.*, vol. 13, no. 1, pp. 1–15, 1994.
- [21] C. Belta and V. Kumar, "An efficient geometric approach to rigid body motion interpolation," in *Proc. ASME 2000 Design Engineering Tech. Conf.*, Baltimore, MD, 2000.
- [22] —, "New metrics for rigid body motion interpolation," in *Proc. Ball 2000 Symp. Commemorating the Legacy, Works, and Life of Sir Robert Stawell Ball*, Univ. Cambridge, Cambridge, U.K., 2000.
- [23] M. P. do Carmo, *Riemannian Geometry*. Boston, MA: Birkhauser, 1992.
- [24] J. M. Selig, *Geometrical Methods in Robotics*. New York: Springer-Verlag, 1996.
- [25] G. H. Golub and C. F. van Loan, *Matrix Computations*. Baltimore, MD: The Johns Hopkins Univ. Press, 1989.
- [26] U. Helmke and J. B. Moore, *Optimization and Dynamical Systems*. Heidelberg, Germany: Springer-Verlag, 1994.
- [27] K. Kanatani, *Geometric Computation for Machine Vision*. Oxford, U.K.: Oxford Science, 1993.
- [28] K. Shoemake and T. Duff, "Matrix animation and polar decomposition," in *Proc. Graphics Interface '92*, May 1992, pp. 258–264.
- [29] R. A. Horn and C. R. Johnson, *Matrix Analysis*. Cambridge, U.K.: Cambridge Univ. Press, 1985.
- [30] F. Bowman, *Introduction to Elliptic Functions With Applications*. New York: Dover, 1961.
- [31] W. H. Press, S. A. Teukolsky, W. T. Vetterling, and B. P. Flannery, *Numerical Recipes in C*. Cambridge, U.K.: Cambridge Univ. Press, 1988.



cellular networks.

Calin Belta (S'00) received the B.S. and M.S. degrees in control and computer science from Technical University of Iasi, Iasi, Romania, and the M.S. degree in electrical engineering from Louisiana State University, Baton Rouge, in 1995, 1996, and 1999, respectively. He is currently working toward the Ph.D. degree in the GRASP Laboratory, University of Pennsylvania, Philadelphia.

His research interests include motion generation for robots and groups of robots, differential geometric control, hybrid systems, and modeling of



Vijay Kumar (S'87–M'87–SM'02) received the M.Sc. and Ph.D. degrees in mechanical engineering from The Ohio State University, Columbus, in 1985 and 1987, respectively.

He has been a Member of the Faculty in the Department of Mechanical Engineering and Applied Mechanics with a secondary appointment in the Department of Computer and Information Science, University of Pennsylvania, Philadelphia, since 1987. He is currently a Professor and the Deputy Dean for Research in the School of Engineering and Applied Science. He serves on the Editorial Boards of the *Journal of the Franklin Institute* and the *ASME Journal of Mechanical Design*. His research interests include robotics, dynamics, control, design, and biomechanics.

Dr. Kumar has served on the Editorial Board of the IEEE TRANSACTIONS ON ROBOTICS AND AUTOMATION. He is a member of the American Society of Mechanical Engineers, Robotics International, and Society of Manufacturing Engineers. He was the recipient of the 1991 National Science Foundation Presidential Young Investigator Award and the 1997 Freudenstein Award for significant accomplishments in mechanisms and robotics.