



2003

A Performance Analysis of Repair Mortars for the Ayyubid Wall of Cairo

Jennifer Elizabeth Cappeto
University of Pennsylvania

Follow this and additional works at: http://repository.upenn.edu/hp_theses

 Part of the [Historic Preservation and Conservation Commons](#)

Cappeto, Jennifer Elizabeth, "A Performance Analysis of Repair Mortars for the Ayyubid Wall of Cairo" (2003). *Theses (Historic Preservation)*. 432.

http://repository.upenn.edu/hp_theses/432

Copyright note: Penn School of Design permits distribution and display of this student work by University of Pennsylvania Libraries.

Suggested Citation:

Cappeto, Jennifer Elizabeth (2003). *A Performance Analysis of Repair Mortars for the Ayyubid Wall of Cairo*. (Masters Thesis). University of Pennsylvania, Philadelphia, PA.

This paper is posted at ScholarlyCommons. http://repository.upenn.edu/hp_theses/432

For more information, please contact libraryrepository@pobox.upenn.edu.

A Performance Analysis of Repair Mortars for the Ayyubid Wall of Cairo

Disciplines

Historic Preservation and Conservation

Comments

Copyright note: Penn School of Design permits distribution and display of this student work by University of Pennsylvania Libraries.

Suggested Citation:

Cappeto, Jennifer Elizabeth (2003). *A Performance Analysis of Repair Mortars for the Ayyubid Wall of Cairo*. (Masters Thesis). University of Pennsylvania, Philadelphia, PA.

UNIVERSITY
PENNSYLVANIA
LIBRARIES



**A PERFORMANCE ANALYSIS OF REPAIR MORTARS
FOR THE AYYUBID WALL OF CAIRO**

Jennifer Elizabeth Cappeto

A THESIS

in

Historic Preservation

Presented to the Faculties of the University of Pennsylvania in
Partial Fulfillment of the Requirements for the Degree of

MASTER OF SCIENCE

2003

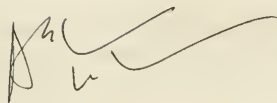

Advisor
Dr. A. Elena Charola
Professor, Historic Preservation

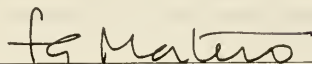

Reader
Frank G. Matero
Associate Professor of Architecture

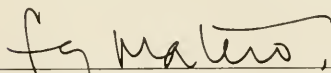

Graduate Committee Chair
Frank G. Matero
Associate Professor of Architecture

File Arch/NA/5/2003/0018

UNIVERSITY
OF
PENNSYLVANIA
LIBRARIES

ACKNOWLEDGEMENTS

I would like to thank several people for their assistance, advice, and resources that helped me throughout this process.

First, I would like to sincerely thank Dr. A. Elena Charola for her direction, advice, and encouragement throughout the year. I appreciate her willingness to share her vast knowledge of lime mortars and surfactants with me, and would not have finished on time without her fast editing and constant suggestions. I would also like to thank Prof. Frank G. Matero for helping me develop the topic and for his recommendations on mortar testing.

I would like to thank Rynta Fourie for being my laboratory advisor and friend, whether she liked it or not. She graciously answered my repeated questions despite her heavy workload.

Elisa del Bono provided me with constant updates on the Ayyubid wall project from Cairo, and with the help of Mr. Zeiad Amer, sent me four boxes of lime putty, brick dust, and wood ash for my testing. Melissa McCormack was also kind enough to hand deliver samples of the sands used in Cairo upon her return from Egypt in December.

Thanks also to James Ferris, PhD, and William Romanow, PhD, at the Laboratory for Research on the Structure of Matter at the University of Pennsylvania for their help with Scanning Electron Microscopy and X-ray diffraction, respectively.

I also appreciate the advice and resources offered by Prof. Koenraad Van Balen of Katholieke Universiteit Leuven, Richard Godbey of Chemical Lime, and Ernesto Borrelli of ICCROM.

Finally, thanks to my family and friends.

TABLE OF CONTENTS

Acknowledgements	i
Table of Contents	ii
List of Figures	vi
List of Tables	vii
List of Graphs	ix
CHAPTER 1: INTRODUCTION	
1.1 Introduction	1
1.2 Present Work	3
1.2.1 Mortars	3
1.2.2 Stone Desalination	6
CHAPTER 2: REVIEW OF STANDARDS FOR MORTAR PERFORMANCE	
2.1 Introduction	7
2.2 Consistency	7
2.2.1 EN 1015-3: 1995 E	9
2.2.2 EN 1015-4: 1995 E	11
2.2.3 ASTM C 143/C 143 M-97	12
2.2.4 ASTM C 187-86 (1991)	13
2.2.5 Current Testing Method	14
2.3 Water Retention	14
2.3.1 EN 1015-8: 1993 E	15
2.3.2 Current Testing Method	17
2.4 Bleeding	17
2.4.1 RILEM MR-6	18
2.4.2 ASTM C 232-92	19
2.4.3 ASTM C 243-95	20
2.4.4 Current Testing Method	22
2.5 Set Time	22
2.5.1 ASTM C 191-92	24
2.5.2 ASTM C 266-89 (1995)	26
2.5.3 ASTM C 403/C 403 M-97	28
2.5.4 ASTM C 807-89 (1995)	29
2.5.5 Current Testing Method	31
2.6 Plasticity	31
2.6.1 ASTM C 110-96a	32
2.6.2 Current Testing Method	33

2.7 Shrinkage	33
2.7.1 ASTM C 596-96	35
2.7.2 ASTM C 1148-92a (1997)	36
2.7.3 EN 1015-13: 1993 E	37
2.7.4 Current Testing Method	39
CHAPTER 3: BEDDING MORTAR TESTS	
3.1 Introduction	40
3.2 Materials	40
3.3 Preparation	44
3.4 Consistency	45
3.4.1 Methodology	45
3.4.2 Materials	47
3.4.3 Results of Consistency Tests	48
3.4.3.1 Lime Putty Mortar	48
3.4.3.2 Natural Hydraulic Lime Mortar	49
3.4.3.3 Portland Cement Mortar	51
3.5 Water Retention	52
3.5.1 Methodology	52
3.5.2 Materials	54
3.5.3 Results of Water Retention Tests	55
3.5.3.1 Lime Putty Mortar	55
3.5.3.2 Natural Hydraulic Lime Mortar	55
3.5.3.3 Portland Cement Mortar	56
3.6 Bleeding	56
3.6.1 Methodology	56
3.6.2 Materials	58
3.6.3 Results of Bleeding Tests	58
3.6.3.1 Lime Putty Mortar	59
3.6.3.2 Natural Hydraulic Lime Mortar	59
3.6.3.3 Portland Cement Mortar	59
3.7 Set Time	63
3.7.1 Methodology	63
3.7.2 Materials	63
3.7.3 Results of Set Time Tests	64
3.7.3.1 Lime Putty Mortar	65
3.7.3.2 Natural Hydraulic Lime Mortar	65
3.7.3.3 Portland Cement Mortar	65
3.8. Shrinkage	67
3.8.1 Methodology	67
3.8.2 Alternative Shrinkage Tests	68

CHAPTER 4: FINISH POINTING MORTAR TESTS

4.1. Introduction	70
4.2. Materials	70
4.3. Preparation	75
4.4. Consistency	76
4.4.1. Methodology	76
4.4.2. Materials	76
4.4.3. Results of Consistency Tests	77
4.4.3.1. Lime Putty Mortar	78
4.4.3.2. Natural Hydraulic Lime Mortar	79
4.4.3.3. Portland Cement Mortar	79
4.5. Water Retention	80
4.5.1. Methodology	80
4.5.2. Materials	80
4.5.3. Results of Water Retention Tests	81
4.5.3.1. Lime Putty Mortar	81
4.5.3.2. Natural Hydraulic Lime Mortar	81
4.5.3.3. Portland Cement Mortar	82
4.6. Bleeding	82
4.6.1. Methodology	82
4.6.2. Materials	82
4.6.3. Results of Bleeding Tests	83
4.6.3.1. Lime Putty Mortar	83
4.6.3.2. Natural Hydraulic Lime Mortar	85
4.6.3.3. Portland Cement Mortar	85
4.7. Set Time	88
4.7.1. Methodology	88
4.7.2. Materials	88
4.7.3. Results of Set Time Tests	89
4.7.3.1. Lime Putty Mortar	89
4.7.3.2. Natural Hydraulic Lime Mortar	90
4.7.3.3. Portland Cement Mortar	91

CHAPTER 5: DISCUSSION AND CONCLUSIONS ON MORTAR TESTING

5.1. Bedding Mortar	93
5.1.1. Consistency	93
5.1.2. Water Retention	93
5.1.3. Bleeding	94
5.1.4. Set Time	95
5.1.5. Conclusion	96

5.2	Finish Pointing Mortar	98
5.2.1	Consistency	98
5.2.2	Water Retention	98
5.2.3	Bleeding	99
5.2.4	Set Time	101
5.2.5	Conclusion	102
5.3	Future Research	104

CHAPTER 6: INFLUENCE OF SURFACTANTS ON SALT CRYSTALLIZATION

6.1	Introduction	105
6.2	Surfactants	105
6.2.1	Cationic Surfactants	109
6.2.2	Anionic Surfactants	109
6.2.3	Nonionic Surfactants	110
6.2.4	Amphoteric Surfactants	110
6.2.5	Wetting and Contact Angle	111
6.3	Effect of Surfactants on Salt Crystallization	113
6.4	Poulticing	114
6.5	Conclusions	123

APPENDICES

Appendix A:	Material Characteristics	126
Appendix B:	Bedding Mortar Tests	145
Appendix C:	Finish Pointing Mortar Tests	172
Appendix D:	Surfactant Data	199

BIBLIOGRAPHY	213
---------------------	-----

INDEX	222
--------------	-----

LIST OF FIGURES

CHAPTER 1

Figure 1.1 Map of the Historic Cairo City Walls and Gates	1
Figure 1.2 Al-Azhar Park Project Map	2

CHAPTER 2

Figure 2.1 Diagram of Flow Table for EN 1015-3: 1995 E	10
Figure 2.2 Diagram of Plunger Apparatus for EN 1015-4: 1995 E	11
Figure 2.3 Diagram of Liquid Displacement Apparatus for ASTM C 243-95	21
Figure 2.4 Vicat Apparatus	24
Figure 2.5 Diagram of Gillmore Needle Apparatus for ASTM C 266-89 (1995)	26

CHAPTER 3

Figure 3.1 Hobart Mixer C-100	44
Figure 3.2 Modified Flow Table	46
Figure 3.3 Detail of Modified Flow Table	46
Figure 3.4 Water Retention Test Set Up	53
Figure 3.5 Water Retention Test in Progress	54
Figure 3.6 Domed Surface of Mortar Sample for Water Retention Test	57
Figure 3.7 Water Retention Test in Progress	57

CHAPTER 6

Figure 6.1 Surfactant Molecules	106
Figure 6.2 Surfactant Organization at Different Concentrations	108
Figure 6.3 Contact Angles	111
Figure 6.4 Diffusion of Surfactant During Wetting	112
Figure 6.5 Egyptian Limestone Control Sample SEM	117
Figure 6.6 Egyptian Limestone Poulitced with Tap Water SEM	117
Figure 6.7 Egyptian Limestone Brushed with Orvus, Poulitced with Water SEM	118
Figure 6.8 Egyptian Limestone Brushed with Orvus, Poulitced with Orvus SEM	118
Figure 6.9 Egyptian Limestone Brushed with Orvus, Poulitced with Triton SEM	119
Figure 6.10 Egyptian Limestone Brushed with Triton, Poulitced with Water SEM	119
Figure 6.11 Egyptian Limestone Brushed with Triton, Poulitced with Triton SEM	120
Figure 6.12 Egyptian Limestone Brushed with Triton, Poulitced with Orvus SEM	120
Figure 6.13 Beakers of Saturated NaCl and Varying Concentrations of Orvus	122
Figure 6.14 Beakers of Saturated NaCl and Varying Concentrations of Triton	123
Figure 6.15 Salt Crystals Growing from a 2% w/v Triton Solution	124

LIST OF TABLES

CHAPTER 1

Table 1.1 Ayyubid Wall Repair Mortar Formulations	4
---	---

CHAPTER 2

Table 2.1 Consistency Tests	9
Table 2.2 Water Retention Tests	15
Table 2.3 Bleeding Tests	18
Table 2.4 Set Time Tests	23
Table 2.5 Plasticity Tests	32
Table 2.6 Shrinkage Tests	35

CHAPTER 3

Table 3.1 Material Proportions for Bedding Mortar	40
Table 3.2 Particle Size Distribution for Sand used in Bedding Mortar Repairs	41
Table 3.3 Particle Size Distribution for Kempf Yellow Concrete Sand	41
Table 3.3 Particle Size Distribution for Bani Yousef Sand	44
Table 3.4 Consistency Tests—Lime Putty Mortar	49
Table 3.5 Consistency Tests—Natural Hydraulic Lime Mortar	50
Table 3.6 Consistency Tests—Portland Cement Mortar	52
Table 3.7 Water Retention—Lime Putty Mortar	55
Table 3.8 Water Retention—Natural Hydraulic Lime Mortar	56
Table 3.9 Water Retention—Portland Cement	56

CHAPTER 4

Table 4.1 Material Proportions for Finish Pointing Mortar	70
Table 4.2 Particle Size Distribution of the Bani Yousef Sand	71
Table 4.3 Particle Size Distribution of the Kempf Yellow Bar Sand	72
Table 4.4 Particle Size Distribution of the El Katameia Sand	73
Table 4.5 Particle Size Distribution of the Schofield Yellow Mason Sand	74
Table 4.6 Consistency Tests—Lime Putty Mortar	78
Table 4.7 Consistency Tests—Natural Hydraulic Lime Mortar	79
Table 4.8 Consistency Tests—Portland Cement Mortar	80
Table 4.9 Water Retention—Lime Putty Mortar	81
Table 4.10 Water Retention—Natural Hydraulic Lime Mortar	82
Table 4.11 Water Retention—Portland Cement Mortar	82

CHAPTER 5

Table 5.1 Bedding Mortar Water Content and Retention Values	93
Table 5.2 Acceptable Binders for Completed Tests—Bedding Mortar	98
Table 5.3 Finish Pointing Mortar Water Content and Retention	99
Table 5.4 Acceptable Binders for Completed Tests—Finish Pointing Mortar	103

CHAPTER 6

Table 6.1 Desalination Results by J. Moon	115
---	-----

LIST OF GRAPHS

CHAPTER 3

Graph 3.1 Particle Size Distribution of Bedding Mortar Sands	42
Graph 3.2 Proportion of Deionized Water to Consistency Measurement for Bedding Mortar with Natural Hydraulic Lime	50
Graph 3.3 Proportion of Deionized Water to Consistency Measurement for Bedding Mortar with Portland Cement	51
Graph 3.4 Bleeding Rate—Lime Putty Mortar	60
Graph 3.5 Cumulative Bleed Water Rate Over Time—Lime Putty Mortar	60
Graph 3.6 Bleeding Rate—Natural Hydraulic Lime Mortar	61
Graph 3.7 Cumulative Bleed Water Rate Over Time—Natural Hydraulic Lime Mortar	61
Graph 3.8 Bleeding Rate—Portland Cement Mortar	62
Graph 3.9 Cumulative Bleed Water Rate Over Time—Portland Cement Mortar	62
Graph 3.10 Set Time—Lime Putty Mortar	66
Graph 3.11 Set Time—Natural Hydraulic Lime Mortar	66
Graph 3.12 Set Time—Portland Cement	67

CHAPTER 4

Graph 4.1 Particle Size Distribution of Bani Yousef and Kempf Yellow Bar Sands	72
Graph 4.2 Particle Size Distribution of El Katameia and Schofield Yellow Mason Sands	74
Graph 4.3 Bleed Rate—Lime Putty Mortar	84
Graph 4.4 Cumulative Bleeding Rate—Lime Putty Mortar	84
Graph 4.5 Bleeding Rate—Natural Hydraulic Lime Mortar	86
Graph 4.6 Cumulative Bleeding Rate—Natural Hydraulic Lime Mortar	86
Graph 4.7 Bleeding Rate—Portland Cement Mortar	87
Graph 4.8 Cumulative Bleeding Rate—Portland Cement Mortar	87
Graph 4.9 Set Time—Lime Putty Mortar	90
Graph 4.10 Set Time—Natural Hydraulic Lime Mortar	91
Graph 4.11 Set Time—Portland Cement Mortar	92

CHAPTER 5

Graph 5.1 Comparison of the Bleeding Rate of Bedding Mortars	94
Graph 5.2 Cumulative Bleed Rate of Bedding Mortar	95
Graph 5.3 Bedding Mortar Set Time Tests	96
Graph 5.4 Bleeding Rates of Finish Pointing Mortars	100
Graph 5.5 Cumulative Bleeding Rates of Finish Pointing Mortar	101
Graph 5.6 Finish Pointing Mortar Set Times	102

CHAPTER 6

Graph 6.1 Moon's Salt Extraction Results—Poulticing with Orvus or Triton; Poulticing with Tap Water	116
--	-----

CHAPTER 1—INTRODUCTION

1.1 Introduction

In 1998, the Aga Khan Trust for Culture (AKTC) began preserving the eastern segment of the Ayyubid wall and a portion of the al-Darb al-Ahmar district in the city of Cairo, Egypt. Constructed in 1176 A.D. by the founder of the Ayyubid dynasty, Sālah ad-Dīn, the Ayyubid wall separates the al-Darb al-Ahmar district of Cairo with the Darassa Hills. As the need for fortification diminished, the population of Cairo spread to the edge of the Ayyubid wall in al-Darb al-Ahmar. This population boom led to the construction of new buildings that incorporated the western side of the wall into their structures. Al-

Darb al-Ahmar residents further concealed the wall by casting refuse outside the fortification that over the centuries formed the rubbish mounds known as the Darassa Hills. By the nineteenth century, a large percentage of the wall was buried beneath nearly thirty meters of debris.¹ The crenellated wall is constructed of a buff Egyptian limestone veneer that is masonry bonded

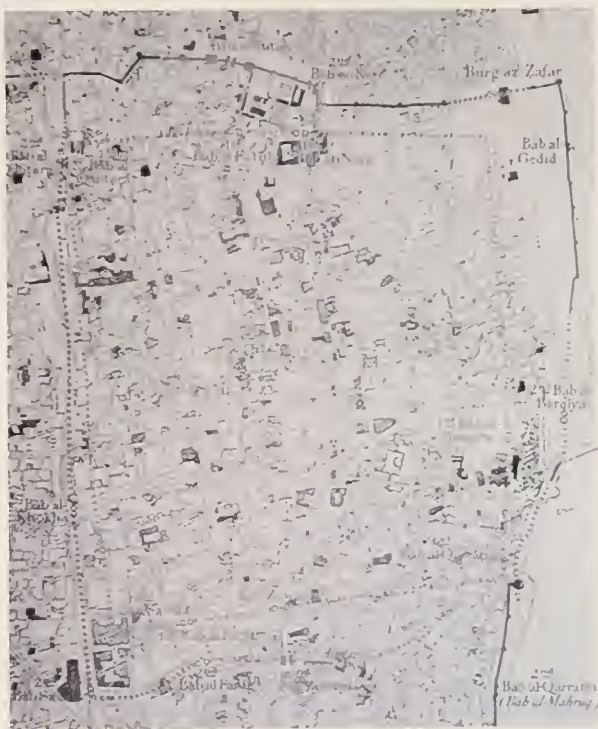

Figure 1.1. Map of the historic Cairo city walls and gates (Creswell, 1952)

¹ Elsa S.O. Bourguignon, "Study of Deterioration Mechanisms and Protective Treatments for the Egyptian Limestone of the Ayyubid City Wall of Cairo" (master's thesis, University of Pennsylvania, 2000), 8.

with lime mortar and a rubble masonry core. The curtain wall is punctuated by rounded towers and the Bāb al-Mahrūq gate. At its highest point, the wall reaches nearly nine meters high and has a depth of three to three and one half meters.

In 1950, the Comité de Conservation des Monuments de l'Art Arabe led the first effort to restore the Ayyubid wall. By replacing damaged and missing stones with newly quarried Egyptian limestone, rebuilding stone towers, and repointing deteriorated mortar joints with Portland cement, the Comité followed preservation practices common for the middle of the twentieth century.² E. Bourguignon's master's thesis of 2000 provides a summarized description of the history and composition of the Ayyubid wall.

The al-Azhar Park project, begun in 1998 by the Aga Khan Trust for Culture, aims to incorporate the Darassa Hills into a ninety acre park in the city of Cairo. The project involves landscaping the debris mounds into public green space and preserving the historic Ayyubid wall. One of the first undertakings of the AKTC in 1998 was the excavation of the eastern



Figure 1.2. The al-Azhar Park Project map, aerial view. The eastern portion of the Ayyubid wall can be seen to the right of the park. (unpublished map, Egypt Ministry of Culture/Aga Khan Trust for Culture).

² Bourguignon, "Deterioration Mechanisms and Protective Treatments," 9.

side of the Ayyubid wall adjacent to the Darassa Hills. A comprehensive condition survey of the eastern portion of the wall was executed in 1999, and a conservation program is currently underway.

Over the last five years, architectural conservators working on the al-Azhar Park project have documented the existing conditions of the wall and researched the use of surfactants on Egyptian limestone to reduce the deterioration caused by the expansion and contraction of the inherent clays of this stone.³ Researchers have also studied the use of surfactants to enhance the extraction of salts present in the stone.⁴ Additional work done in 2000 characterized the historic mortar applied to the wall prior to the Comité restoration effort in the 1950s; modern repair mortar formulations were also developed at this time.⁵

1.2 Present Work

This thesis will compare, through fresh mortar testing, the lime putty mortar currently used to repair the Ayyubid wall with formulations based on natural hydraulic lime, and Portland cement. It will also examine the influence of surfactants on the crystallization of salts in Egyptian limestone.

1.2.1 Mortars

In 1999, architectural conservators analyzed the historic mortars used to construct and repair the Ayyubid wall over its long history, including reconstruction efforts in the 1950s. These mortars were analyzed through extensive laboratory testing, the results of

³ Bourguignon, "Deterioration Mechanisms and Protective Treatments"; Melissa McCormack, "Conservation Studies for the Ayyubid City Wall, Cairo" (master's thesis, University of Pennsylvania, 2001).

⁴ Judi J. Moon, "A Study to Improve Desalination Methodologies for the Ayyubid City Wall, Cairo" (master's thesis, University of Pennsylvania, 2002).

⁵ Rynta Fourie, "Mortar Characterization and Analysis: Ayyubid City Wall, Cairo, Egypt" (unpublished report), 2000.

which were used to develop compatible mortar formulations for repairing the wall.⁶ The historic pointing mortar was found to contain gypsum and lime binders with calcareous aggregate and a small amount of crushed brick, whereas the bedding mortar consisted of a lime binder and coarse aggregate. In 2000, Thomas Roby, an architectural conservator working on the Ayyubid wall, tested different mortar formulations and binders and developed the mortar formulations currently being used to repair the wall.

Two mortar formulations are currently used in the Ayyubid wall conservation project. These include a bedding mortar used for deep mortar loss in the limestone veneer and for the replacement of Portland cement mortars applied during the Comité restoration of the 1950s, and a finish pointing mortar used to repair visible joints on the wall surface. The bedding mortar consists of 2.5 parts masonry sand (by volume), 0.5 parts brick dust, and 1 part high-calcium lime putty. The finish pointing repair mortar was formulated to match the original mortar in color and texture to produce a uniform appearance on the wall. This mortar is made of a dry mix composed of sand, brick dust, and wood ash, which is added to lime putty in a 3:1 proportion. Table 1.1 lists the mortar formulations used to repair the Ayyubid wall.

Table 1.1. Ayyubid Wall Repair Mortar Formulations

Material	Bedding Mortar	Finish Pointing Mortar
High-Calcium Lime Putty	1 part (by volume)	1 part (by volume)
Aggregate	2.5 parts	3 parts (mixture)*
Brick dust	0.5 parts	-

***Mixture of dry ingredients for the finish pointing mortar formulation in the following proportions:**

Dry Ingredients	Volume
Bani Yousef Sand	30 parts
El Katameia Sand	20 parts
Brick Dust	2 - 3 parts
Wood Ash	1.5 - 2 parts

⁶ Fourie, "Mortar Characterization and Analysis."

The lime putty is composed of high-calcium lime sieved to remove impurities from the burning process, and slaked on site in Cairo. The lime putty is stored under water for a minimum of three months duration to improve the plasticity and workability of the lime.⁷ The brick dust is produced by crushing red brick from demolition projects and serves as a pozzolanic additive to improve mechanical resistance of the mortar. The wood ash used in the Ayyubid wall repair mortar is produced from wood from Abu El Nomros that is incompletely burned to form a fine black powder, and serves to increase moisture retention during curing.⁸

This thesis involves performance testing on the two mortar formulations to determine their efficacy with Egyptian limestone masonry and their function as repointing mortars in the Ayyubid wall project. These formulations will be compared to similar mortar formulations containing natural hydraulic lime or Portland cement binders. Testing will be carried out on fresh mortar samples to determine the consistency (known as “slump” in the United States), water retention, bleeding, and set time. Shrinkage testing will also be performed on the hardened mortars in a non-cured state. The tests will conform to American or European standards, such as those defined by the American Society for the Testing of Materials (ASTM), the European Committee for Standardization (CEN), and the International Union of Testing and Research Laboratories for Materials and Structures (RILEM) recommendations.

Due to the extensive curing time required for lime mortars, the testing of cured mortars will be completed in future work. Tests on cured mortars should include water absorption, water vapor permeability, bond strength, bulk density, and salt resistance. Tests will conform to ASTM, CEN, and Italian NORMAL standards.

⁷ John Ashurst, *Mortars, Plasters and Renders in Conservation: A Basic Guide* (London: Ecclesiastical Architect's and Surveyors' Association, 1983): 10.

⁸ Mark M. Goodman, “The Effects of Wood Ash Additive on the Structural Properties of Lime Plaster” (master's thesis, University of Pennsylvania, 1998): 66.

1.2.2 Stone Desalination

Desalination is a major concern for architectural conservators working on the Ayyubid wall. Egyptian limestone contains a naturally high amount of salts due to its formation by the precipitation of calcium carbonate, gypsum, and halite from seawater in ancient sea beds.⁹ Furthermore, the stones used on the Ayyubid wall have been exposed to additional salts present in the soil of the Darassa Hills. The stone also has a high clay content and is susceptible to swelling from differential moisture content during the daily heating and cooling cycles typical in Cairo. Previous thesis work on the Ayyubid wall by E. Bourguignon¹⁰ focused on the use of a cationic surfactant (BDAC) as a means to minimize the shrinkage and swelling of the clays in the stone. M. McCormack evaluated the use of BDAC to improve the desalination of the stone by poulticing,¹¹ and J. Moon tested the efficacy of other surfactants commonly used in conservation (Triton™ XL-80N and Orvus WA paste) to enhance desalination of the stone.¹²

This thesis focuses on changes in the crystal habit of sodium chloride due to stone desalination with anionic and nonionic surfactants. Scanning electron microscopy and simple laboratory experiments will determine how Triton and Orvus surfactants change the size and shape of sodium chloride extracted from Egyptian limestone samples. These tests will be performed to determine if surfactant-treated stone will effect the bond strength of the repair mortar formulations. It will also encourage further research into the effect of surfactants on crystal growth associated with lime mortars and pozzolanic reactions.

⁹ Bourguignon, "Deterioration Mechanisms and Protective Treatments," 19.

¹⁰ Bourguignon, "Deterioration Mechanisms and Protective Treatments."

¹¹ McCormack, "Conservation Studies."

¹² Moon, "Desalination Methodologies."

CHAPTER 2—REVIEW OF STANDARDS FOR MORTAR PERFORMANCE

2.1 Introduction

The current testing program was developed on the basis of American and European standards. Testing recommendations and standards were evaluated on their ease of performance, their applicability to lime mortars, and the availability of materials or apparatus needed for the testing procedures. Tests performed on fresh mortar will include consistency (known as “slump” in the United States), water retention, bleeding, and set time. Shrinkage tests were performed on hardened, non-cured mortar. Tests on cured mortar will be performed in future research. This chapter analyzes the benefits and drawbacks of various American and European standards for each test performed.

The current research is based on the following standards for each property test:

- **Consistency:** EN 1015-3: 1995 E *Determination of Consistence of Fresh Mortar (by Flow Table)*
- **Water Retention:** EN 1015-8: 1993 E *Determination of Water Retentivity of Fresh Mortar*
- **Bleeding:** RILEM MR-6 *The Tendency of Water to Separate from Mortars (Bleeding)*
- **Set Time:** ASTM C 191-92 *Standard Test Method for Time of Setting of Hydraulic Cement by Vicat Needle*
- **Shrinkage:** ASTM C 1148-92a (1997) *Standard Test Method for Measuring the Dry Shrinkage of Masonry Mortar.*

Plasticity was not tested in the current program due to the unavailability of the Emley Plasticimeter required for this test. Nonetheless, the ASTM standard for plasticity will be evaluated in this chapter.

2.2 Consistency

According to the European standard EN 1015-3: 1995 E *Determination of Consistence of Fresh Mortar (by Flow Table)*, consistency measures:

the fluidity and/or wetness of the fresh mortar and gives a measure of the deformability of the fresh mortar when subjected to a certain type of stress.

The consistence however is not directly associated with the manner in which the fresh mortar handles when used by a craftsman.¹

It is possible to determine the appropriate amount of water to use during mixing by testing the consistency of a mortar or concrete mixed under comparable atmospheric conditions. A mortar with low consistency—a great measured difference between the tested mortar and the original shape of the mortar—usually contains a large quantity of water and will commonly have low ultimate strength. Conversely, a mortar with high consistency—a small measured difference between the tested mortar and the original shape of the mortar—has little mixing water and often displays greater ultimate strength. It is important to note, however, that this inverse relationship of consistency to strength is clear only when consistency tests are performed under laboratory conditions; this relationship is not reliably proven in tests performed in the field.² Consistency testing is also important because it provides uniformity of the mortar batches for additional testing.

A variety of American and European standards were compared to assess and develop a test methodology, including EN 1015-3: 1995 E *Determination of Consistence of Fresh Mortar (by Flow Table)*, EN 1015-4: 1995 E *Determination of Consistence of Fresh Mortar (by Plunger Penetration)*, ASTM C 143/C 143M-97 *Standard Test Method for Slump of Hydraulic-Cement Concrete*, and ASTM C 187-86 (1991) *Standard Test Method for Normal Consistency of Hydraulic Cement*. Table 2.1 compares these standards.

¹ EN 1015-3: 1995 E, "Methods of Test for Mortar For Masonry--Part 3: Determination of Consistency of Fresh Mortar (by Flow Table)" (Brussels: European Committee for Standardization, 1995), 4.

² ASTM C 143/C 143M-97, "Standard Test Method for Slump of Hydraulic-Cement Concrete," Vol. 4.02 of *1998 Annual Book of ASTM Standards* (West Conshohocken, PA: American Society for Testing and Materials, 1998), 89.

Table 2.1 Consistency Tests

	EN 1015-3: 1995 E	EN 1015-4: 1995 E	ASTM C143/ C143M-97	ASTM C187-86
Test method	flow table	plunger penetration	flow table	plunger penetration
Mold material	non-porous, non-absorbent	non-porous	non-corrosive metal	non-porous, non-absorbent
Mold shape	Vicat	cylindrical vessel	cone	Vicat
Size of sample	40 mm (1.57 in.) depth, 70 mm (2.76 in.) base diameter, 60 mm (2.36 in.) top diameter	80 mm (3.15 in.) diameter, 70 mm (2.76 in.) depth	12 in. (304.8 mm) depth, 8 in. (203.2 mm) base, 4 in. (101.6 mm) top	40 mm (1.57 in.) depth, 70 mm (2.76 in.) base diameter, 60 mm (2.36 in.) top diameter
Required apparatus	flow table	Vicat apparatus with 90 g (0.20 lb) plunger	n/a	Vicat apparatus with 10 mm (0.39 in.) plunger
Benefits	Complicated flow table can be simplified to achieve same results	Easy to construct apparatus; may be performed in field or in laboratory	Requires no apparatus	Provides consistency range for hydraulic cement
Drawbacks	Provides no values for appropriate consistency	Provides no values for appropriate consistency	Provides no values for appropriate consistency	Only for hydraulic cement

2.2.1 EN 1015-3: 1995 E

EN 1015-3: 1995 E *Determination of Consistence of Fresh Mortar (by Flow Table)* is a common European standard test for consistency. A flow table as described by this standard consists of a stand, a stiff table plate and disk, a shaft and lifting cam, and a lifting spindle (Figure 2.1). The test also requires a rigid, non-porous mold with an internal diameter of 100 mm (3.94 in.) at the base and 70 mm (2.76 in.) at the top, and a height of 60 mm (2.36 in.). Also required are a tamper, calipers, a trowel, and a palette knife.

One and one half liters of mortar should be mixed according to the pre-determined formulation. The mold should be cleaned, dried, and rubbed with a

lubricant such as a non-resin mineral oil, and the flow table should be tested a minimum of ten times prior to usage. The mold is placed on the flow table and is filled with mortar in two layers, each layer being tamped at least ten times. Any excess mortar should be removed from the mold with a horizontal movement of the palette knife. The filled mold is to remain on the center of the flow table for fifteen seconds, after which time the mold is vertically lifted from the table. The flow table should be lifted with the lifting cam a total of fifteen times at a speed of one drop per second. The consistency of the mortar is determined by measuring with calipers the diameter of the diffuse mortar.

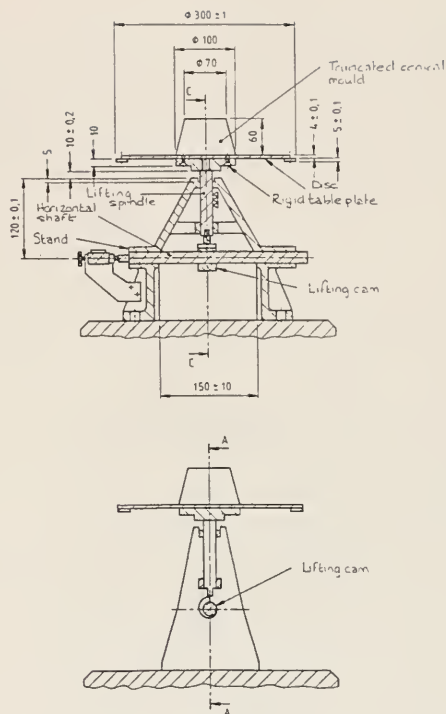

Figure 2.1. Diagram of Flow Table used for EN 1015-3: 1995 E.

Although this standard does not give an explanation of proper consistency values for lime-based mortar, it is possible to extrapolate the appropriate consistency by repeatedly testing mixtures of mortar with different quantities of mixing water. The flow table described in this standard is relatively complicated to construct; however, a simplified version of the table may be devised to replicate the flow table operation.

2.2.2 EN 1015-4: 1995 E

EN 1015-4: 1995 E *Determination of Consistence of Fresh Mortar (by Plunger Penetration)* is an alternative European consistency standard. This standard requires a plunger apparatus composed of a plunger stand, base plate, frame, clamp, cylindrical vessel, and a penetration rod with a cylindrical plastic plunger weighing 90 g (Figure 2.2). The penetration rod has a graduated scale divided in 1 mm (0.04 in.) increments capable of measuring 100 mm (3.94 in.). The test also requires a tamper, a trowel, and a palette knife.

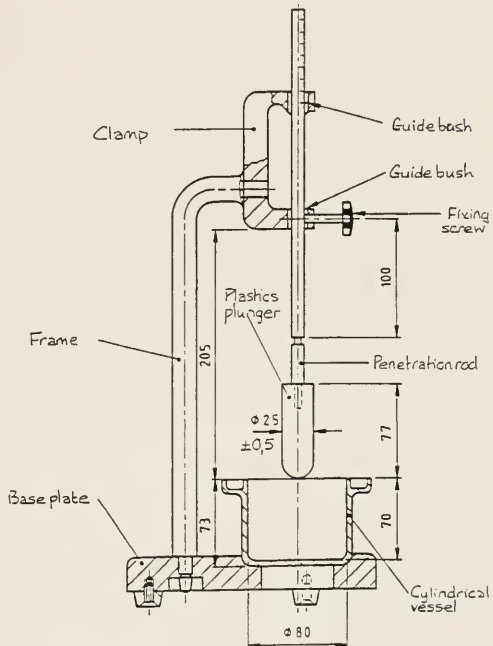

Figure 2.2. Diagram of Plunger Apparatus Required for EN 1015-4: 1995 E.

One and one half liters of each mortar formulation are mixed and the mold is filled in two layers, each layer being tamped at least ten times. Excess mortar should be removed by scraping the palette knife over the surface of the mold in a rapid horizontal movement. The penetration rod of the plunger apparatus is placed 100 mm (3.94 in.) above the mold and is released by turning the fixing screw. Consistency is determined by measuring the depth that the plunger has penetrated the mortar.

The penetration apparatus may be easily constructed with common laboratory equipment or materials purchased from a hardware store, and may be performed in the field or in a laboratory setting.

2.2.3 *ASTM C 143/C 143M-97*

ASTM C 143/C143M-97 Standard Test Method for Slump of Hydraulic-Cement Concrete tests for the consistency of hydraulic-cement, although it can be adapted to measure the consistency of mortars. The mortar is placed in a non-corrosive metal mold shaped like the frustum of a cone. The mold must conform to the following dimensions: a base diameter of 8 in. (203.2 mm), a top diameter of 4 in. (101.6 mm), and a height of 12 in. (304.8 mm). Both the base and top of the mold should be open, and the mold should be made without a seam. A tamping rod is also required for this consistency standard.

The mold should be placed on a rigid, non-absorbent, pre-moistened surface, and filled in three layers with mortar. Each layer of mortar is uniformly tamped twenty-five times. Excess mortar should be removed by rolling the tamping rod horizontally across the top surface of the mold. Immediately after the mold is filled, it should be removed by lifting vertically and placed next to the sample on the moist surface. Consistency is determined by comparing the difference in height between the top of the mortar and the top of the mold. The test should be repeated if the mortar shears when the mold is removed. If repeated shears occur, the mortar is too moist and does not have an appropriate plasticity to perform the consistency test.

This test method, like the European standards discussed above, does not offer values for appropriate consistency measurement. These numbers may be extrapolated by repeated testing of multiple mortar mixtures. The standard is simple and requires a mold rather than an apparatus.

2.2.4 ASTM C 187-86 (1991)

ASTM C 187-86 (1991) *Standard Test Method for Normal Consistency of Hydraulic Cement* determines the amount of water needed to mix hydraulic cement to an appropriate consistency. It requires a Vicat apparatus with a modified plunger end that can be moved vertically a distance of 50 mm (1.97 in.). The vertical distance moved by the plunging rod is measured by an adjustable indicator along a 50 mm (1.97 in.) scale measured in 1 mm (0.04 in.) increments. The plunger should be 10 mm (0.39 in.) in diameter. The mortar is placed in a conical ring mold, commonly known as a Vicat mold, laid flush against a glass plate approximately 1000 mm² (15.52 in.²). The mold is made of a hard, non-corrosive, non-absorbent material that has a height of 40 mm (1.57 in.) and an interior diameter of 70 mm (2.76 in.) at the base and 60 mm (2.36 in.) at the top. Several 200 mL glass graduated cylinders are also required for this test.

The mortar should be mixed according to ASTM C 305 and a portion of the fresh mortar should be hand-molded into a ball that is tossed “six times from one hand to the other, maintaining the hands about 6 in. (152 mm) apart.”³ The Vicat mold is inverted so the larger end is upright and the narrower opening is flush to the glass plate. The molded ball of mortar is hand-pressed into the larger end of the Vicat mold to completely fill the mold. Any excess mortar should be removed from the larger end of the mold with a quick horizontal hand movement. The mold is again inverted on the glass plate with the smaller opening upright and excess mortar is removed from the narrow end with a quick trowel stroke. The mortar should not be compressed during the second inversion of the mold, nor should compression occur during the cutting motion with the trowel. Consistency is measured by

³ASTM C 191-92, “Standard Test Method for Time of Setting of Hydraulic Cement by Vicat Needle.” Vol. 4.01 of *1998 Annual Book of ASTM Standards* (West Conshohocken, PA: American Society for Testing and Materials, 1998), 165.

resting the plunger on the surface of the mortar, setting the indicator to the highest point, and releasing the plunger into the mortar. The mortar has reached an appropriate consistency when the plunger settles 10 mm (0.39 in.) below the surface of the mold. Several tests should be performed on mortar mixed with varying amounts of water.

This standard for consistency is clear and easily performed if one has the correct modification to the Vicat apparatus as described above. It also provides a range for appropriate consistency of hydraulic mortar, something which is lacking in other American and European standards; however, this range cannot be used to determine the appropriate consistency for Portland cement mortars or lime putty mortars.

2.2.5 *Current Testing Method*

Tests for consistency of fresh mortar will be performed following EN 1015-3 *Determination of Consistence by Fresh Mortar (by Flow Table)*. A modified flow table was constructed to duplicate the function of the table specified in the standard.

2.3 **Water Retention**

Water retention measures the ability of a mortar or cement to reduce moisture loss during hardening. Low water retention causes mortar to lose strength, crack, shrink, or have low bond strength. By studying the water retention properties of mortars, conservators can determine proper curing conditions, as well as which mortars are applicable to certain climatic conditions or different masonry systems. Lime mortars that set rapidly under hot, dry conditions may not have sufficient time for carbonation, causing low ultimate strength.⁴ For example, pointing mortars used in arid climates

⁴ John Ashurst and Nicola Ashurst, *Mortars, Plasters, and Renders*, vol. 3 of *Practical Building Conservation* (Hants, England: Gower Technical Press, 1989), 4.

such as Cairo should retain water sufficiently during setting to decrease shrinkage and reduce the setting rate. Additionally, mortars with high water retention should be used with masonry units characterized by high capillarity and suction. Although high water retention can be beneficial at times, H. McKee suggests that mortars with more than five percent water content will not permit sufficient carbonation.⁵

Only one standard—EN 1015-8: 1993 E *Determination of Water Retentivity of Fresh Mortar*—is available for testing the water retention of mortar. Table 2.2 summarizes EN 1015-8: 1993 E. The standard developed by ASTM for testing water retention (ASTM C 156-95) is applicable only to concrete that has been sprayed or sealed with liquid membrane or precut sheet curing materials. Those materials are rarely used for mortars, so the ASTM standard is not appropriate for the present work.

Table 2.2. Water Retention Testing

	EN 1015-8
Test method	fresh mortar
Mold material	rigid, non-absorbent
Mold shape	cylindrical
Size of sample	100mm (3.94 in.) diameter, 25mm (0.98 in.) depth
Required apparatus	2 kg weight 100mm (3.94 in.) in diameter
Benefits	Easy procedure; can be performed in a lab or in the field
Drawbacks	

2.3.1 EN 1015-8:1993 E

EN 1015-8: 1993 E *Determination of Water Retentivity of Fresh Mortar* is the only comprehensive standard available for water retention tests on mortar. This standard requires a cylindrical, non-absorptive mold 100 mm (3.94 in.) in diameter and

⁵Harley J. McKee, *Introduction to Early American Masonry* (Washington, D.C.: National Trust for Historic Preservation, 1977), 65.

25 mm (0.98 in.) deep. Also required for this test is a 2 kg (4.41 lbs.) weight fitting the diameter of the mold, a palette knife, a balance, a non-porous plane plastic or glass surface 120 mm (4.72 in.) diameter and 5 mm (0.20 in.) thick, a weighing boat or other non-absorptive plane surface, two disks of white cotton gauze 100 mm (3.94 in.) in diameter, and eight disks of absorbent filter paper. The filter paper should have a specific mass of 200 g/m² and a water absorption capacity of 160 g/m², and should fit into the internal diameter of the mold.

The mortar must be tested for appropriate consistency as specified in EN 1015-2 prior to determining its water retention. After the mortar has been mixed and an appropriate consistency achieved, the mortar should be tested for water retention; this test should be performed no sooner than ten minutes following mixing, and no later than the “workable life of the mortar,” or thirty minutes following mixing.⁶

The dry mold, eight disks of filter paper and two disks of cotton gauze, and weighing boat should be weighed prior to filling the mold. The mold is laid flat in the weighing boat and filled with a palette knife in approximately ten layers. Excess mortar is removed by striking the palette knife at a 45° angle across the surface of the mold in a single motion; a second swipe of the palette knife is performed in the opposite direction to completely remove any excess mortar. The mold, weighing boat, and wet mortar are weighed together, and the mortar is covered with two pieces of the cotton gauze followed by eight pieces filter paper. The entire assembly is covered by the flat plastic or glass disk and inverted. The 2 kg (4.41 lbs.) weight is loaded onto the open end of the mold. After a period of five minutes, the weight is removed, the mold once again inverted onto the weighing boat, and the filter paper and cotton gauze are removed from the mold and weighed. The mass of the filter paper and gauze should not increase by more than 10 grams (0.02 lbs.); if this occurs, additional pieces of filter paper should

⁶ EN 1015-8: 1993 E, “Methods of Test for Mortar--Part 8: Determination of Water Retentivity of Fresh Mortar” (Brussels: European Committee for Standardization, 1993), 5.

be added to a new test specimen until the water absorbed is within the water absorption capacity of the filter paper.

A fourth mold should be filled on a weighing boat, weighed, and placed in a 70°C (158°F) oven to remove moisture from the mortar. The mass of the mortar should be weighed until two identical masses are measured. The moisture content of the mortar is the difference between the wet and dry mortar masses, divided by the dry mortar mass.

2.3.2 Current Testing Method

Due to its simplicity, ease of performance, and applicability to both lime-based and Portland cement mortars, EN 1015-8: 1993 E was selected for the current testing program. Multiple samples of each mortar formulation were tested to determine the average water retention of the mortar under uniform conditions.

2.4 Bleeding

Bleeding is the tendency of mix water to separate from freshly mixed mortar before hardening. This important property allows conservators to determine which mortar formulation is applicable to particular climatic conditions. Mortars that bleed a substantial amount of mixing water have low ultimate strength, as the binder leaches out in the bleeding process. Excess water can also activate salts and other soluble products present in associated masonry. This property is particularly pertinent to the study of the Ayyubid wall repair mortars due to the wall's salt-laden Egyptian limestone construction. European and American standards, as well as RILEM recommendations, were reviewed for bleeding testing. These tests include the RILEM MR-6 recommendation *The Tendency of Water to Separate from Mortars (Bleeding)*, ASTM C 232-92 *Standard Test Method for Bleeding of Concrete*, and ASTM C 243-95 *Standard Test Method for Bleeding of Cement Pastes and Mortars*. Table 2.3 compares these test methods.

Table 2.3. Bleeding Tests

	RILEM MR-6	ASTM C232-92	ASTM C243-95
Test method	mortars	concrete	cement mortars
Mold material	n/a	n/a	metal
Mold shape	n/a	n/a	cylindrical
Size of sample	n/a	n/a	127 mm (5 in.) diameter, 102 mm (4.02 in.) high
Required apparatus	600 mL beakers	metal container capable of holding 14.16 L or 0.5 ft ³ of mortar	liquid displacement bleeding apparatus
Benefits	Simple test; May be performed in the lab or in the field	Method A (similar to RILEM MR-6) is simple and easily performed	Measures bleeding and consistency
Drawbacks	Requires a large quantity of mortar	Method B is more complicated; neither test can be easily performed in the field	Involves the use of a complicated apparatus and a toxic chemical

2.4.1 RILEM MR-6

The International Union of Testing and Research Laboratories for Materials and Structures (RILEM) has developed several recommendations for mortar testing, including MR-6 *The Tendency of Water to Separate from Mortars (Bleeding)*. This recommendation is relatively simple and may be performed either in the laboratory or in the field. It requires fourteen beakers with spouts that hold a volume of 600 mL, two 10 mL graduated cylinders measured with 0.1 mL gradations, a 20 mL pipette measured with 0.1 mL gradations, an ordinary stainless steel spoon and knife, a 10 L rounded mixing container, and a stop watch. There is no mold required for this test.

Approximately 5 L of mortar should be mixed according to the formulations and stirred prior to placing the mortar into the beakers; only five beakers are used per batch of mixed mortar. Exactly 500 mL of mortar is placed in each beaker with a tablespoon. Care should be taken not to shake or tamp the mortar when filling the beakers. The mortar is cut with the table knife in horizontal movements to remove any air pockets and the beaker is covered with a watch glass for approximately fifteen minutes.

Bleeding should be measured fifteen minutes, thirty minutes, one, two and four hours after mixing the mortar. The recommendation offers two methods for measuring bleed water. In Method A, bleeding is measured by tilting each beaker with the spout against a 10 mL graduated cylinder. Any excess liquid should be poured directly into the graduated cylinder taking care not to shake the beaker or pour any mortar into the cylinder. Method B requires removing the bleed water from the surface of the beaker with a graduated pipette. The amount of water bled from the mixture should be recorded at each measurement, as well as the time of measurement.

This test is simple and can be performed in the laboratory or on site. The times of measurement and procedure are applicable both to lime-based and Portland cement mortars as well as those mixes modified with water retention agents (*e.g.*, wood ash).

2.4.2 ASTM C 232-92

ASTM developed two standards to test bleeding from mortars, including ASTM C 232-92 *Standard Test Method for Bleeding of Concrete*. Although this test was designed specifically for concrete, it can be used for any mortar formulation. This test determines the how various factors effect bleeding, such as the environment in which the mortar is stored, and the composition of the mortar. The standard requires a scale, pipet of unspecified volume, a 100 mL graduated cylinder, a tamper, and a cylindrical container capable of holding 14.16 L or one-half of a cubic foot of mortar. The metal container should have an inside diameter of 10 in. (254 mm) and a height of 11 in. (279.4 mm). There is no mold required for this test.

The mortar should be mixed according to ASTM C 192 and should be poured into the metal container to a depth of 10 in. (254 mm). The mortar should be lightly troweled to create a smooth surface, then covered to prevent evaporation and placed on a stable, level surface. Approximately eight minutes after mixing, the container should be slightly

tilted by raising one side by 2 in. (50.8 mm). Any excess mortar should be drawn off the surface of the mortar with the pipet; this should occur every ten minutes for the first forty minutes, then every half hour until bleeding is no longer evident. The container should be level in the interval between measurements, but can be tilted by 2 in. (50.8 mm) no more than two minutes before each test. The pipet should be emptied into the 100 mL graduated cylinder and the volume of bleed water measured after each test.

An alternative test method outlined in this standard involves vibrating the mortar to consolidate the material. The container should be mounted to a vibrating platform and the sample should be repeatedly vibrated for three seconds, with a thirty second pause between vibration intervals. Vibration should be repeated until the surface of the mortar in the container is smooth and bleed water appears. The mortar should be intermittently vibrated for a period of one hour, followed by a single measurement of bleed water. The container should be tilted on one side by 2 in. (50.8 mm) and the bleed water should be collected with the pipet.

The first part of this test method is similar to the RILEM MR-6 recommendation; however, it is not as applicable for field testing as the RILEM recommendation. Additionally, the second test method requires a complicated vibration apparatus to separate bleed water from the mortar.

2.4.3 *ASTM C 243-95*

ASTM C 243-95 *Standard Test Method for Bleeding of Cement Pastes and Mortars* is an alternative to the RILEM recommendations and ASTM C 232-92. This standard is far more complicated than the previously discussed bleeding tests and focuses on the bleeding rate and capacity of cement mortar. A liquid displacement bleeding apparatus is required for this test (Figure 2.3). It is composed of a cylindrical metal container 127 mm (5.00 in.) in diameter and 102 mm (4.02 in.) high; a non-corrosive

metal flanged collecting ring 76 mm (2.99 in.) in diameter; a glass funnel with an outside diameter of 73.7 mm (2.90 in.); and a glass buret capable of measuring 25 mL of liquid. An aspirator, stopcock, and constricted capillary are connected to the top of the buret. Also required for this test are a mechanical mixer, a flow table and flow mold conforming to ASTM C 230.

Once the mortar is mixed as outlined in the standard, its consistency should be determined as specified in ASTM C 109, in which the flow table is dropped ten times from a height of 13 mm (0.51 in.)

during a six-second interval. The mortar has an appropriate consistency when it has a flow between 105 and 110. Following the consistency test, the mortar is remixed for thirty seconds and poured in three layers into the measurement container. The mortar is tamped forty times between each layer. The surface of the mortar should be level with the rim of the measurement container. The entire liquid displacement bleeding apparatus should be placed in a fume hood or in a well ventilated room at this point in the test. The collecting ring is lowered 19.1 mm (0.75 in.) into the mortar, which is then covered with approximately 500 mL of 1,1,1-trichloroethane, a toxic substance that is dangerous if absorbed through the skin or inhaled in vapor form. The 1,1,1-trichloroethane should be

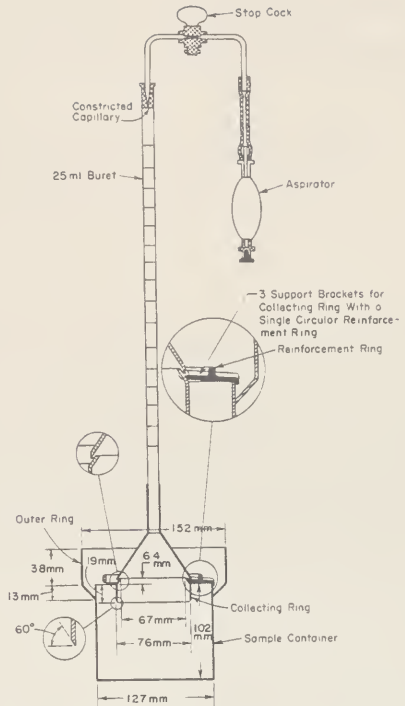

Figure 2.3. Diagram of the Liquid Displacement Bleeding Apparatus required for ASTM C 243-95.

drawn with the aspirator into the buret to the 0 mL mark. Measurements are taken every two minutes for the first thirty minutes after the container was filled, and then every ten minutes until bleeding is no longer apparent.

Although this standard provides the most accurate method for calculating bleeding, it requires the use of a complicated apparatus and a toxic chemical.

2.4.4 Current Testing Method

Bleeding tests followed the RILEM MR-6 recommendation Method A due to its simplicity and applicability to lime-based and Portland cement mortars. The test was performed over multiple days with different mortar formulations; therefore, the test were modified to measure the temperature and relative humidity of the laboratory. Consistent laboratory conditions reduce fluctuations between bleeding measurements on different days.

2.5 Set Time

Set time measures the rate at which mortars or cements harden under specific laboratory conditions. Set time measurement is important when evaluating the applicability of mortar formulations for different masonry systems. For example, fast drying mortar may be pertinent for use in moist climates with an imminent risk of frost. Additionally, fast drying mortar may be used for bedding mortar that will be sealed and covered with veneer materials. Similarly, slow drying mortar may be necessary in arid climates where mortar could dry and shrink too rapidly. Set time may be affected by both the temperature and amount of water used for mixing, the length of mixing, and the temperature and humidity of the air in which the mortar is stored.

Standards for testing set time differ on their definition of setting; some standards indicate that set occurs when the mortar is fully hardened while others offer a value for

setting in which the mortar is mostly hardened but still has some plasticity. Four ASTM standards were evaluated for their usefulness with lime mortar. These tests include ASTM C 191-92 *Standard Test Method for Time of Setting of Hydraulic Cement by Vicat Needle*, ASTM C 266-89 (1995) *Standard Test Method for Time of Setting of Hydraulic-Cement Paste by Gillmore Needles*, ASTM C 403/C 403M-97 *Standard Test Method for Time of Setting of Concrete Mixtures by Penetration Resistance*, and ASTM C 908-89 (1995) *Standard Test Method for Time of Setting of Hydraulic Cement Mortar by Modified Vicat Needle*. Table 2.4 compares these standards.

Table 2.4. Set Time Tests

	ASTM C191-92	ASTM C266-89	ASTM C403/ C403M-97	ASTM C807-89
Test method	Vicat needles	Gillmore needles	penetration resistance	Modified Vicat
Mold material	non-porous, non-absorbent	n/a	rigid, non-porous	brass
Mold shape	Vicat	n/a	cylindrical or rectangular	cylindrical ring
Size of sample	40 mm (1.57 in.) depth, 70 mm (2.76 in.) base diameter, 60 mm (2.36 in.) top diameter	76 mm (2.99 in.) bottom, 50 mm (1.97 in.) top, 13 mm (0.51 in.) depth	at least 6 in. (152.4 mm) wide and 6 in. (152.4 mm) high	76 mm (2.99 in.) diameter, 40 mm (1.57 in.) depth
Required apparatus	Vicat apparatus	Gillmore apparatus	penetration needles are hand pushed, needs device to measure force	Vicat with 17.5 mm (0.69 in.) plunger
Drying Temp	20-27.5 °C (68-81.5 °F)	20-27.5 °C (68-81.5 °F)	20-25 °C (68-77 °F)	20-27.5 °C (68-81.5 °F)
Drying Relative Humidity	90%	50%	n/a	50%
Benefits	Offers initial and final set values; apparatus and mold are readily available	Offers initial and final set values	Can be performed in the lab or in the field	Tests both consistency and time of set
Drawbacks	High RH does not permit setting of lime putty mortars	Gillmore needles not as readily available as Vicat apparatus	Complicated apparatus and procedure	

2.5.1 ASTM C 191-92

ASTM C 191-92 *Standard Test Method for Time of Setting of Hydraulic Cement by Vicat Needle* is commonly used to measure set time of mortar or cement. This test requires a Vicat mold and apparatus (Figure 2.4) as described above for ASTM C 187-86 (1991), but it requires a thinner needle—1 mm (0.04 in.) in diameter as opposed to 10 mm (0.39 in.) required by the previously discussed standard. A scale and several 200 mL or 250 mL graduated cylinders are also necessary for the test.

The mortar should be mixed according to standard as required by the formulation. Distilled water should be used to mix the mortar to an appropriate consistency. The mortar should be placed in the mold in the same fashion as explained in ASTM C 187-86

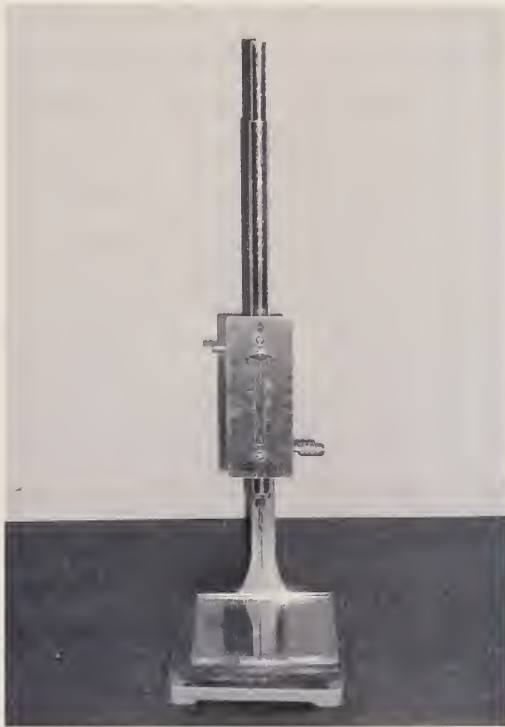

Figure 2.4. Vicat apparatus

(1991). Immediately after molding, the mold, mortar, and glass plate should be stored in a chamber with a constant temperature between 21.3 and 24.7°C (70.4 and 76.4°F) and a relative humidity no less than 90%.

To perform the set time test, the Vicat needle is lowered flush with the surface of the mortar and fastened into place by the set screw. The indicator is set to the top of the graduated scale so that it reads fifty on the left and zero on the right. The set screw must be quickly released at the designated time,

allowing a thirty second interval for the needle to settle prior to taking the penetration measurement. The needle must be gently cleaned after each test to prevent any mortar from hardening on the needle. No two penetrations should be performed closer than 0.25 in. (6.35 mm) apart, and tests should be done no closer than 0.38 in. (9.65 mm) from the edge of the mold.

According to this standard, penetration measurements should occur thirty minutes after molding followed by tests every fifteen minutes until the initial set time is achieved. The initial set time of the mortar occurs when the needle stops at a depth of 25 mm (0.98 in.), and final set occurs when the penetrometer no longer descends into the mortar.

ASTM C 191-92 is a simple procedure requiring an apparatus and mold available in many conservation laboratories. The test was designed for the measurement of hydraulic lime; however, the test method may be modified to determine the set time of different mortar formulations. Lime mortar can take several days to completely harden in a mold, and it takes years for lime mortar to fully harden in a thick masonry wall.⁷ Therefore, when testing lime mortar it is important to increase the time between penetrations so as to reduce the number of penetration holes in the mortar, thus reducing the opportunity for differential setting. Suggested intervals for penetration testing of lime mortar are fifteen minutes, two hours, five hours, and twenty-four hours following the molding process.⁸ The relative humidity of the storage chamber should be lowered to 50% when testing lime putty mortars. This lower relative humidity value, based on the French Centre Scientifique et Technique du Batiment (CSTB) standards, was found to increase compressive strength, flexural strength, and modulus of elasticity in lime putty mortars cured at 50% relative humidity.⁹

⁷ McKee, *Introduction to Early American Masonry*; 65.

⁸ Jeanne Marie Teutonico, Iain McCaig, Colin Burns and John Ashurst, "The Smeaton Project: Factors Affecting the Properties of Lime-Based Mortars," *APT Bulletin* 25, no. 3-4 (1994): 37.

⁹ Fernando M.A. Henriques and A. Elena Charola, "Comparative Study of Standard Test Procedures for Mortars," *Proceedings of the 8th International Congress on Deterioration and Conservation of Stone*. ed. J. Riederer (Berlin: Moeller Druck und Verlag, 1996), 1521-1528.

ASTM C 191-92 does not account for inconsistencies in mortar mixes. The penetration tests should be performed at regular distances from each other, beginning near one edge of the mold and spiraling inward toward the center. Mortar along the edges of the mold will set more rapidly than the mortar in the center of the mold due to its proximity to the mold surface. Therefore, penetration tests spiraled toward the center of the mold will produce more accurate results.

2.5.2 ASTM C 266-89 (1995)

An alternative set time test is ASTM C 266-89 (1995) *Standard Test Method for Time of Setting of Hydraulic-Cement Paste by Gillmore Needles*. This standard

necessitates the use of a Gillmore needle apparatus composed of two needles (Figure 2.5). The initial set time needle weighs 113.4 g (0.25 lbs.) and has a tip diameter of 2.12 mm (0.08 mm). The final set time needle weighs 453.6 g (1.0 lb.) and has a tip diameter of 1.06 mm (0.04 in.). The needles are mounted in a cross-arm fashion to prevent horizontal rotation and to allow for height adjustment. The end of each needle is cylindrical 4.8 mm (0.19 mm) from the tip and ends in a flat, horizontal plane. Additional materials required for this test

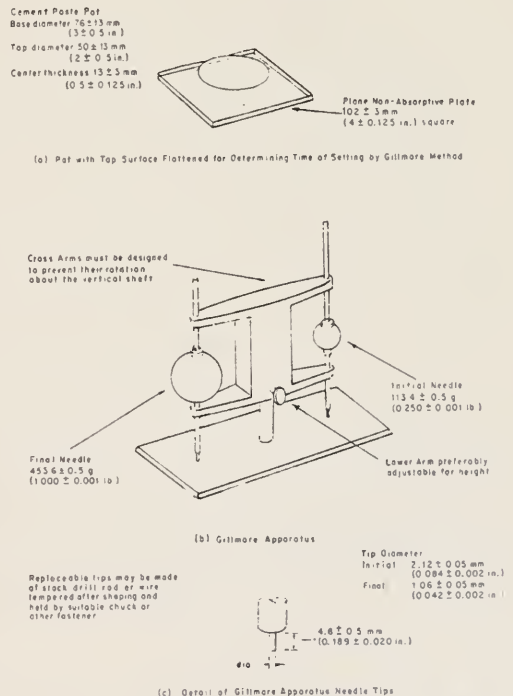

Figure 2.5. Diagram of Gillmore Needle Apparatus from ASTM C 266-89 (1995)

include a trowel, a mixer, bowl, scraper, and paddle, glass graduated cylinders, a scale, and plane non-absorptive plates 102 mm (4.02 mm) square. There is no mold required for this test.

The mortar should be mixed according to standards established in ASTM C 305 in the appropriate proportions as required by the formulation. Distilled water is not required for this test. The mortar should be formed into a “pat” 13 mm (0.51 in.) in height with a base diameter of 76 mm (2.99 in.) and a top diameter of 50 mm (1.97 in.). The standard recommends molding the pat on a non-absorptive base plate by “flatten[ing] the cement paste first on the plate and then form[ing] the pat by drawing the trowel from the outer edge toward the center, then flattening the top.”¹⁰ The pat and base plate should be placed in a moist storage conforming to the specifications in ASTM C 511.

When determining the set time with Gillmore needles, the needles must be placed just above the mortar pat so that the needle tip is lightly touching the surface of the mortar. The mortar has achieved initial set when the mortar can support the initial set Gillmore needle without indentation; the mortar has achieved final set when it can support the final set Gillmore needle without indentation. Between penetration tests, the mortar pat should be returned to a storage chamber with constant temperature between 20 and 27.5 °C (68 and 81.5 °F) with a relative humidity of 50%.

This standard has fewer specifications than ASTM C 191-92. For example, it does not explain how the Gillmore needles drop vertically onto the mortar pats. Additionally, the standard does not specify time intervals between tests or minimum distances between penetrations. The test methodology is less clear than ASTM C 191-92, making this test inappropriate for the current testing needs.

¹⁰ASTM C 266-89 (1995), “Standard Test Method for Time of Setting of Hydraulic-Cement Paste by Gillmore Needles,” vol. 4.01 of *1998 Annual Book of Standards* (West Conshohocken, PA: American Society for Testing and Materials, 1998), 195.

2.5.3 ASTM C 403/C 403M – 97

ASTM C 403/C 403M – 97, *Standard Test Method for Time of Setting of Concrete Mixtures by Penetration Resistance* was developed for the set time measurement of concrete, although it may be used for other mortars. This test can be performed under field conditions or in the laboratory and measures the effects of water content, admixtures, and the amount of binder on the set time of cement, mortar, or grout.

A loading apparatus is required to measure the force needed to penetrate various needles into the mortar. The apparatus must have a loading capacity of 130 foot pounds (lbf) (29.23 Newton [N]) and have an accuracy of ± 2 lbf (0.45 N). Penetration needles with bearing areas of 1, $\frac{1}{2}$, $\frac{1}{4}$, $\frac{1}{10}$, $\frac{1}{20}$, and $\frac{1}{40}$ in.² are attached to the loading apparatus, each inscribed with a mark 1 in. (25.4 mm) from the bottom of the needle. The mortar should be stored in several rigid, watertight, non-absorptive containers measuring at least 6 in. (152.4 mm) in height, length, and width. A tamping rod, a pipet, and a thermometer with an accuracy of $\pm 1^\circ\text{F}$ are also needed for this test procedure.

Mortar should be mixed according to ASTM Practice C 172 on a non-absorptive surface. The temperature of the mortar (or the room in which the mortar is mixed) should be recorded. The mortar is immediately placed in containers in a single layer, tamped once for each square inch of surface area to remove air, and leveled to a height at least 0.5 in. (12.7 mm) below the top of the container. Mortar samples should be stored at a temperature between 68 and 77°F (20 and 25°C) and covered to prevent rapid moisture evaporation.

Prior to set time testing, accumulated bleed water is removed by siphoning the surface of the mortar with a pipet. Set time tests are performed by attaching an appropriate needle to the loading apparatus, lowering the needle to the top surface of the mortar, and slowly pushing on the apparatus with a uniform, vertical force until the needle penetrates the mortar to the 1 in. (25.4 mm) mark. This action should occur

over a ten second period and the force should be recorded along with elapsed time. No two penetrations should be closer than two diameters of the needle used for testing, nor should any penetration take place less than 1 in. (25.4 mm) from the side of the container. The first set time test for concrete should be performed approximately three to four hours after initial mixing, followed by tests every thirty to sixty minutes with a minimum of six test penetrations for each mortar. The test is complete when penetration resistance measures 4000 psi or greater.

This standard was designed for the testing of concrete mixtures; however, it may be modified for use on lime-based mortars by extending the testing times to accommodate the prolonged set time typical of lime mortars.

2.5.4 *ASTM C 807 – 89 (1995)*

ASTM C 807 – 89 (1995) Standard Test Method for Time of Setting of Hydraulic Cement Mortar by Modified Vicat Needle uses a modified Vicat apparatus with a plunger end measuring 17.5 mm (0.69 in.) in diameter and weighing 400 g (0.88 lbs.). Additionally, the set time needle should be 2 mm (0.08 in.) in diameter, as opposed to the 1 mm (0.04 in.) needle used in ASTM C 191-92, and the mass of the entire rod should be 300 g (0.66 lbs.). The standard requires a cylindrical brass ring mold 76 mm (2.99 in.) in diameter with a height of 40 mm (1.57 in.). The brass ring should be cemented to a plane, non-absorptive plate. A tamper, trowel, mixer, bowl, paddle, scraper, and glass graduated cylinders are also required for this test.

The mortar should be mixed either according to cement specifications in the standard, or should follow ASTM C 305. Immediately after mixing, a layer of freshly mixed mortar 20 mm (0.79 in.) thick is placed in the mold and tamped with fourteen strokes spaced equally around the edge of the mold and four strokes in the center of the mold. The mold should be overfilled with another layer of mortar and tamped in the

same method. The trowel should be held 10 mm (0.39 in.) above the mold at a twenty degree angle and swept across the mold to remove excess mortar. A second stroke should be performed at the opposite edge of the mold with the trowel nearly perpendicular to the mold. Excess mortar should be returned to the mixing bowl, which is covered during testing.

The consistency test is performed thirty-five to fifty seconds after filling the mold. To test for consistency, the mold is placed under the movable rod of the Vicat apparatus immediately after packing. The apparatus is set with the plunger lightly touching the top of the mortar and the indicator set to read zero on the right side of the scale. The set screw is released at the designated time, allowing thirty seconds for the rod to settle. The mortar has a desired consistency when the plunger drops 20 mm (0.79 in.) below the original surface. Tests for consistency should be performed on mortars mixed with various amounts of water.

The set time test is performed on the mortar remaining in the bowl that has achieved appropriate consistency. The mortar should be remixed in the bowl at medium speed (285 rpm) for thirty seconds and remolded according to the consistency test specifications. The mold is stored in a container conforming to ASTM C 511 for thirty minutes. Despite a modified Vicat apparatus, the set time test in this standard is performed identically to the set time test in ASTM C 191-92. Tests should be performed every thirty minutes until the mortar begins to harden, at which point tests should be performed every ten minutes until the needle penetrates to a distance of 10 mm (0.39 in.). Penetration tests should be no closer than 10 mm (0.39 in.) from each other or the mold edges.

Although the procedure outlined in this standard is simple, the number of test penetrations required for the set time would exceed the minimum test distance if used for lime-based mortar. Therefore, this test needs to be adapted for use with lime mortar.

2.5.5 Current Testing Method

A modified form of ASTM C191-92 was used to test set time in the current testing program. The test was modified to accommodate mortars made with lime putty. Modifications include extending the testing times for lime putty mortars, and storing the mortars at 50% relative humidity rather than the 90% relative humidity required by the standard.

2.6 Plasticity

Plasticity measures the workability of a material and its ability to retain water.¹¹ “A material is the more plastic which has the greater ability to retain its water against the suction of the surface to which it is applied...[and] requires the less work to spread it.”¹² Plasticity determines the ease with which a mason can apply the mortar to a wall, and how well the mortar can adhere to the wall. Therefore, it is an important property to study when determining the correct mortar formulation for different substrates.

ASTM developed a standard for plasticity—C 110-96a—based on the Emley Plasticimeter, a complicated device developed by Emley after over a decade of research and trials. Table 2.5 provides a summary of ASTM C 110-96a.

¹¹ Warren E. Emley, “Measurement of Plasticity of Mortars and Plasters,” *Department of Commerce Technologic Papers of the Bureau of Standards*, No. 169 (Washington, D.C.: Government Printing Office, 1920), 7.

¹² Emley, “Measurement of Plasticity,” 7.

Table 2.5. Plasticity Testing

	ASTM C 110-96a
Test Method	fresh mortar
Mold Material	rigid, non-absorbent
Mold Shape	Vicat
Size of Sample	40 mm (1.57 in.) deep, 70 mm (2.76 in.) base diameter, 60 mm (2.36 in.) top diameter
Required Apparatus	Emley Plasticimeter
Benefits	only test available for plasticity measurement
Drawbacks	expensive apparatus

2.6.1 ASTM C 110-96a

ASTM C 110-96a requires the use of an Emley Plasticimeter, which was designed to replicate the work of a plasterer by measuring the application force and the rate of mortar drying.¹³ ASTM C 110-96a omits description of the apparatus, but the function of the plasticimeter is described in detail by Emley. The plasticimeter contains round absorbent plaster blocks 25 mm (0.98 in.) thick and 100 mm (3.94 in.) in diameter that absorb a minimum of 40 g (0.09 lbs.) in twenty-four hours; these base plates are cleaned and oven dried for twenty-four hours after each test. A rigid, conical mold used for the Vicat apparatus is lubricated with water and placed on one of the dry plaster base plates.

Mortar is mixed according to formulation and placed in the Vicat mold; excess mortar is removed by striking the surface of the mold with a trowel. The mold should immediately be removed, and the base plate is raised manually until the surface of the mortar contacts a disk that is 0.8 mm (0.03 in.) thick and 76 mm (2.99 in.) in diameter; this disk represents the motion of the mason's trowel.¹⁴ The motor should be started immediately; the total duration of molding and raising the mortar to the disk should be

¹³ Emley, "Measurement of Plasticity," 17.

¹⁴ Emley, "Measurement of Plasticity," 18.

no more than 120 seconds. The motor revolves the base plate 360 degrees in six minutes and forty seconds, and moves the base plate vertically 2 mm (0.08 in.) per revolution. The plaster base plate absorbs water from the mortar while the rotation and upward motion of the plate against the disk flattens the mortar onto the base plate. Measurements from the scale should be recorded every minute until the scale reaches one hundred, when successive readings are more than those previously recorded, or when the reading is constant for three consecutive readings.

This standard offers a brief description of the Plasticimeter and its function. Any tests performed with the Emley Plasticimeter, however, should be done after reading Emley's treatise on plasticity.¹⁵ This article describes the research that went into the development of the Plasticimeter, and provides a detailed discussion of the function of the machine and an analysis of the results. The major drawback to this standard is the expense of the Plasticimeter that precludes its general availability.

2.6.2 Current Testing Method

The current thesis does not explore plasticity testing due to the unavailability of an Emley Plasticimeter. Workability was tested by performing a simple inverted trowel test following mixing, and the water retention of the mortar was examined using EN 1015-8: 1993 E *Determination of Water Retentivity of Fresh Mortar*, as described in Section 2.3.1.

2.7 Shrinkage

Shrinkage is the change in length of a masonry mortar during setting and curing. Shrinkage is directly influenced by the suction power of the stone or masonry unit to which the mortar is applied, and is also affected by temperature and relative humidity of

¹⁵ Emley, "Measurement of Plasticity."

the laboratory or application site. Shrinkage is related to the workability of the mortar. For example, lime mortar, which is extremely plastic, has a high moisture content and can be reworked after several hours or days of drying. This material will have more shrinkage than Portland cement as it undergoes a physical reaction with the masonry substrate during absorption to provide good adhesion and mortar strength. Conversely, the portlandite in Portland cement chemically reacts with the water during setting to produce a hard mortar with low workability and low absorption; this material will generally have low shrinkage.

The standards available for shrinkage differ in their curing conditions and time between measurements. Three American and European standards were compared, including ASTM C 596-96 *Standard Test Method for Drying Shrinkage of Mortar Containing Hydraulic Cement*, ASTM C 1148-92a (1997) *Standard Test Method for Measuring the Drying Shrinkage of Masonry Mortar*, and EN 1015-13: 1993 E *Determination of Dimensional Stability of Hardened Mortars*. Table 2.6 provides a summary of the tests.

Table 2.6. Shrinkage Tests

	ASTM C 596-96	ASTM C 1148-92 (1997)	EN 1015-13: 1993 E
Test method	hydraulic cement	fresh mortar	hydraulic or lime mortar
Mold material	steel	steel	steel
Mold shape	rectangular prism	rectangular prism	rectangular prism
Size of sample	1 in. (25.4 mm) high, 1 in. (25.4 mm) deep, 11.25 in. (285.75 mm) long	1 in. (25.4 mm) high, 1 in. (25.4 mm) deep, 11.25 in. (285.75 mm) long	40 mm (1.57 in.) high, 40 mm (1.57 in.) deep, 175 mm (6.89 in.) long
Required apparatus	Length comparator	Length comparator	Length comparator
Curing Temp	23°C (73.4°F)	23°C (73.4°F)	20°C (68°F)
Curing Relative Humidity	95% for 23.5 hours then wet cure for 48 hours; alternative curing: 95% for 70.5 hours, wet cure for 24 hours	95% for 48 hours then 50% for 24 hours	95% for 2 days (hydraulic mortar) and 95% for 5 days (non- hydraulic mortar); 50% until test is complete
Benefits	simple procedure	simple procedure	provides different mold- ing and curing condi- tions for hydraulic and lime putty mortars
Drawbacks	must be modified for use with lime putty mortars	does not provide mea- surement times; must be modified for use with lime putty mortars	cure time must be extended for lime putty curing

2.7.1 ASTM C 596-96

ASTM C 596-96 *Standard Test Method for Drying Shrinkage of Mortar*

Containing Hydraulic Cement tests the drying shrinkage, or change in length of a molded mortar, caused by the temperature, relative humidity, and evaporation rate of the curing chamber. The test was developed for hydraulic cement mortars, but can be adapted for lime-based mortars.

The standard requires a mold that is 1 in. (25.4 mm) high, 1 in. (25.4 mm) deep, and 11.25 in. (285.75 mm) long. The mold should have a gage length of 10 in. (254 mm) calculated by measuring the length between the innermost end of the studs. The mold

should be steel, and should hold the stainless steel studs approximately 0.63 in. (15.88 mm) into the mortar. A length comparator with a dial micrometer and steel reference bar is required for the test, as are several graduated cylinders, a trowel, and a tamper.

The mortar should be prepared and molded according to ASTM C 305 and should be stored in a moist chamber for twenty-three and one half hours at which point the mortars are removed from the mold. The temperature and relative humidity of the moist chamber should be maintained at 23°C (73.4°F) and approximately 95% RH. The de-molded mortar should be placed in water to cure for forty-eight additional hours for a total duration of seventy-one and one half hours. If the mortar does not achieve sufficient strength after twenty-three and one half hours in the moist storage chamber, it should remain in the chamber until the total time elapsed is forty-seven hours, after which time it is de-molded and placed in water to cure for an additional twenty-four hours (for a total curing duration of seventy and one half hours). The length change is measured with the length comparator when the mortar is removed from the water.

This test method is relatively simple and the mold and apparatus are available at many conservation laboratories. However, the standard does not specify intervals at which shrinkage should be measured. Furthermore, curing conditions must be modified if testing lime putty mortars by maintaining the relative humidity of the chamber at 50%, omitting wet curing, and extending the cure time to assure that lime mortars are sufficiently hard to remove from the mold.

2.7.2 *ASTM C 1148-92a (1997)*

ASTM C 1148-92a (1997) Standard Test Method for Measuring the Drying Shrinkage of Masonry Mortar also measures the length change of mortar as it dries, and is extremely similar to ASTM C 596-96. It differs from the previously discussed standard only in curing conditions.

The molds, apparatus, and materials required for this test are identical to those specified in ASTM C 596-96. Five test samples should be molded according to ASTM C 157 and should be stored in a moist storage container with a temperature of 23°C (73.4°F) and relative humidity of 95% for forty-eight hours. The mortars should be removed from the mold at this point and returned to the moist storage container for an additional twenty-four hours (for a total of seventy-two hours of curing). After seventy-two hours of moist curing, the mortars are placed in a dry storage chamber with a temperature of 23°C (73.4°F) and a relative humidity of 50% until the test is complete. Shrinkage is measured with a length comparator seventy-two hours from molding, and again after four days, eleven days, fifteen days, and twenty-five days after molding.

This standard is more applicable to non-hydraulic mortars than ASTM C 596-96, although lime putty mortars will not have sufficient hardness to be removed from the mold after seventy-two hours in moist storage. Once again, the standard should be modified for use with lime putty mortars by curing the mortars in a storage chamber at 50% relative humidity.

2.7.3 EN 1015-13: 1993 E

EN 1015-13: 1993 E *Determination of Dimensional Stability of Hardened Mortars* is more applicable for measuring the shrinkage of lime putty mortars than the ASTM standards discussed above. This European standard requires steel molds with the following dimensions: 40 mm (1.57 in.) high, 40 mm (1.57 in.) deep, 175 mm (6.89 in.) long, and walls 8 mm (0.31 in.) thick. Steel studs 10 mm (0.39 in.) in diameter and 10 mm (0.39 in.) long should be screwed into the mold. The standard requires a length comparator capable of measuring differences of 0.002 mm (0.00008 in.) and a steel calibration bar. Also required for the test are a scale, a 5 kg (11.02 lb.) weight, glass plates, a clamp, four sheets of cotton gauze measuring 150 x 175 mm (5.91 x 6.89 in.),

a tamper, and twelve sheets of filter paper with a specific mass of 200 g/m² and a water absorption capacity of 160 g/m², and dimensions identical to that of the cotton gauze.

The test provides different molding methods for hydraulic lime mortars and lime, or lime plus cement mortars. Hydraulic lime mortars should be placed in the mold in two layers, each layer being tamped twenty-five times. Lime, or lime plus cement mortars should be placed in a mold that has been clamped onto a glass plate with two layers of cotton gauze between the glass and the mold. The mortar is put in the mold in two layers, each layer being tamped twenty-five times, and excess mortar is removed by a horizontal movement with a trowel. Two layers of gauze should be placed on top of the molded mortar with six pieces of filter paper placed on top of the gauze. The filter paper should be covered with a glass plate and the mold is inverted. The glass plate is removed from the top, and six additional pieces of filter paper should be added to the top of the mold. The mold is covered again with the glass plate, inverted again, and loaded with the 5 kg (11.02 lb.) weight. The weight, layers of gauze, and filter paper should be removed after three hours.

Hydraulic lime mortars should be stored in a moist storage container with a temperature of 20°C (68°F) and a relative humidity of 95% for two days. The lime, or lime plus cement mortar should be stored in the same container for five days. Both mortars should be removed from the mold, measured with the length comparator, and placed in a dry storage container with a temperature of 20°C (68°F) and a relative humidity of 50% until the test is completed. Measurements should be taken after seven days, fourteen days, twenty-eight days, fifty-six days, and ninety-one days after the mortar was removed from the mold.

This standard is more detailed than the ASTM standards previously discussed, and provides separate directions for molding and curing hydraulic lime and lime, or lime plus cement mortars. It is important for lime putty mortars to have an absorbent, rigid mold

to replicate field conditions and to reduce shrinkage caused by excess water in the mold.¹⁶ It is unlikely that lime mortars stored in a moist cabinet will have sufficient strength to be safely removed from the mold after five days curing, and this specification must be modified.

2.7.4 *Current Testing Method*

A modified form of ASTM C 1148-92 (1997) was followed for shrinkage testing. The mortars were stored in a dry storage container with a relative humidity of 50% for seventy-two hours prior to removing the mortar from the mold and measuring the length change.

¹⁶A. Elena Charola and F.M.A. Henriques, "Lime Mortars: Some Considerations on Testing Standardization," *Use of and Need for Preservation Standards in Architectural Conservation*, ASTM STP 1355, ed. L.B. Sickels-Taves (West Conshohocken, PA: American Society for Testing and Materials, 1999), 6.

CHAPTER 3—BEDDING MORTAR TESTS

3.1 Introduction

The bedding mortar used to repair the deep mortar and associated stone loss on the wall veneer consists of 2.5 parts masonry sand, 0.5 parts brick dust, and 1 part high-calcium lime putty. All proportions are measured by volume. Table 3.1 shows the proportions of materials used for the bedding mortar repairs.

Table 3.1. Material Proportions for Bedding Mortar

Material	Volume	Percentage
Binder	1 part	25%
Masonry Sand	2.5 parts	62.5%
Brick Dust	0.5 parts	12.5 %

Tests will be performed according to the standards outlined in Chapter 2, and will be compared to mortars of identical proportions containing natural hydraulic lime, and Portland cement binders.

The materials used to test the performance of the bedding mortar include lime putty and brick dust sent from Cairo, as well as Kempf yellow concrete sand, Riverton natural hydraulic lime, and Portland cement purchased in Pennsylvania.

3.2 Materials

The masonry sand used for these mortars is quarried in Bani Yousef, Giza. It is light yellowish brown to dark yellowish brown in color (matching Munsell 10YR 6/4 to 10 YR 6/6) and is sieved through a #4 ASTM standard sieve to remove aggregate larger than 1.85 in. (4.70 mm). The mortar is not visible from the outside of the wall making the color of the sand less important than its particle size distribution. Approximately 72% of the sand grains are between 1180 and 300 μm (0.05 and 0.01 in.) in size, and the sand contains less than one percent fine particles below 75 μm (0.003 in.). Table 3.2 provides the particle size distribution for this sand.

Table 3.2. Particle Size Distribution for Sand Used in Bedding Mortar Repairs

ASTM Sieve Number	Screen Size (μm)	Mass of container (g)	Mass of container & sample (g)	Mass retained (g)	Percent mass retained	Percent on and above	Percent passing
8	2360	6.55	12.73	6.18	4.46	4.46	95.54
16	1180	6.85	23.85	17.00	12.25	16.71	83.29
30	600	6.67	55.64	48.97	35.30	52.01	47.99
50	300	6.57	57.78	51.21	36.92	88.93	11.07
100	150	6.65	17.94	11.29	8.14	97.07	2.93
200	75	6.70	9.42	2.72	1.96	99.03	0.97
Pan	0	6.80	7.96	1.16	0.84	99.86	0.14

The laboratory analysis of the sand can be found in Appendix A.

The sand used in Cairo was unavailable for use in the current testing program, and was replaced by American sand similar in particle size distribution and mineral content to the Cairo sand. The yellow concrete sand (purchased from George F. Kempf Building Materials Supply Company in Philadelphia) has a comparable grain size distribution to the masonry sand. This sand contains approximately 75% of its mass between 1180 and 300 μm (0.05 and 0.01 in.) in size, and has less than one percent fine particles below 75 μm (0.003 in.). Table 3.3 shows the particle grain size distribution of the Kempf yellow concrete sand used in laboratory testing of the bedding mortar.

Table 3.3. Particle Size Distribution of Kempf Yellow Concrete Sand

ASTM Sieve Number	Screen size (μm)	Mass of container (g)	Mass of sample & container (g)	Mass retained (g)	Percent mass retained	Percent on or above	Percent passing
8	2360	7.16	13.28	6.12	5.38	5.38	94.62
16	1180	6.84	30.60	23.76	20.88	26.26	73.74
30	600	7.14	48.41	41.27	36.27	62.52	37.48
50	300	7.31	41.13	33.82	29.72	92.24	7.76
100	150	7.16	15.19	8.03	7.06	99.30	0.70
200	75	7.09	7.67	0.58	0.51	99.81	0.19
Pan	0	7.19	7.28	0.09	0.08	99.89	0.11

The X-ray diffraction analysis of the sand can be found in Appendix A. Graph 3.1 compares the particle size distribution of the Kempf Yellow Concrete Sand used in this

thesis to the Bani Yousef sand used in Cairo to prepare the bedding mortar.

Graph 3.1. Particle Size Distribution of Bedding Mortar Sands

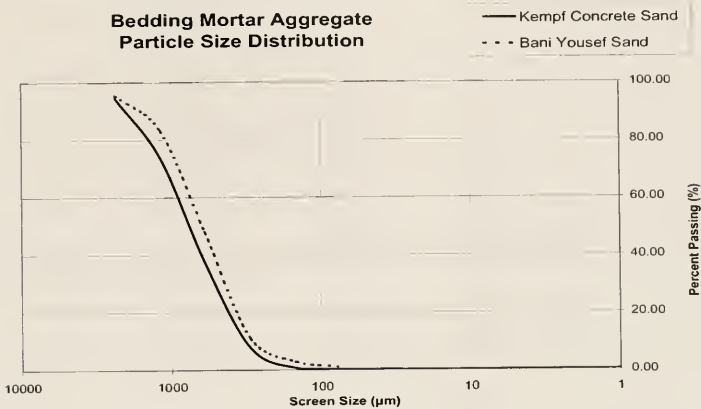

Brick dust used in the Ayyubid wall repair mortar is produced by finely crushing red bricks from Egyptian demolition projects, and is sieved through a #30 ASTM standard sieve to remove particles larger than 600 µm (0.02 in.) prior to mixing with the sand and lime putty. Brick dust is added to the mortar as a pozzolanic component, yet laboratory tests were unable to determine any pozzolanic reaction.¹ Researchers believe that brick dust below 75 µm (0.003 in.) facilitates the pozzolanic reaction, while brick dust particles larger than 300 µm (0.01 in.) in diameter act as an air entrainer to aid in carbonation and mortar resistance.² Pozzolanicity is directly related to the firing temperature of the brick. Bricks fired between 600 and 900 °C (1112 and 1652 °F) are generally believed to provide hydraulicity.³ The brick dust used in the Ayyubid wall repair mortar is red in color (matching Munsell 10R 4/6 to 10R 4/8) characteristic of “the

¹ G&W Science and Engineering Company analysis, “Characterization of Lime Putty, Wood Ash, and Brick Powder—Historical Ayyubid Wall” (December 18, 2002), 2.

² Teutonico, et al. “Smeaton Project,” 41-42.

³ A. Elena Charola and Fernando M.A. Henriques, “Hydraulicity in Lime Mortars Revisited,” *Proceedings of the International Workshop Historic Mortars: Characteristics and Tests*, eds. P.J.M. Bartos, C.J.W. Groot and J.J. Hughes (Cachan, France: RILEM, 2000), 98.

red brick manufactured from the river mud of argillaceous [sic] materials.”⁴ Appendix A provides a laboratory analysis of this material.

Prior to slaking, the lime putty used for the Ayyubid wall repairs is sieved to remove impurities during the limestone burning process. X-ray diffraction analysis of the lime indicates it is highly pure with a free lime content of 97% and no insoluble residue.⁵ Further data from the laboratory analysis can be found in Appendix A. The lime is slaked on site in Cairo for a minimum of three months. As previously mentioned, this slaking period increases the workability and plasticity of the lime. Slaking for a period longer than three months, however, may provide additional benefits to the lime. A recent study by E. Hansen et al. indicates that lime putty slaked for two years increases the reactivity of calcium hydroxide with carbon dioxide in the atmosphere.⁶

In order to compare the performance of the lime putty mortar used to repair the Ayyubid wall, consistency, water retention, bleeding, and set time tests were also performed on two other mortars containing either Riverton natural hydraulic lime or Portland cement. The natural hydraulic lime was purchased from the Riverton Corporation in October 2002 by the University of Pennsylvania’s Architectural Conservation Laboratory (ACL). The material is a fine, white powder composed of calcium carbonate [CaCO_3], calcium hydroxide [$\text{Ca}(\text{OH})_2$], and calcium silicate [$\text{Ca}_2(\text{SiO}_4)$]. Riverton natural hydraulic lime is produced by burning clay-rich limestone and grinding it through a hammer mill. Sulfuric acid and water are added to the resultant powder to hydrate the lime for twenty-four hours, after which the material is milled. An X-ray diffraction analysis of this material can be found in Appendix A.

⁴ G&W analysis, 2

⁵ G&W analysis, 2.

⁶ Eric F. Hansen, Alberto Tagle, Evin Erder, Susan Baron, Samuel Connell, Carlos Rodriguez-Navarro, and Koenraad Van Balen, “Effects of Ageing on Lime Putty,” in *International RILEM Workshop on Historic Mortars: Characteristics and Tests* (Paisley, Scotland: RILEM Publications S.A.R.L., 1999): 200.

Type I Portland cement powder is a fine, gray powder produced by Capitol Cement, and is used as a binder in the current testing program. The Portland cement contains calcium carbonate [CaCO_3], sodium calcium silicate [$\text{Na}_4\text{Ca}_8\text{Si}_5\text{O}_{20}$], and calcium silicate [Ca_3SiO_5]. An X-ray diffraction analysis of this material can be found in Appendix A.

3.3 Preparation

The mortars were mixed based on standard ASTM C 305-94 practice with a Hobart C-100 mixer (Figure 3.1) for approximately five minutes prior to testing. The sand, brick dust, and binder were placed in the mixing bowl, respectively, mixed at Speed 1 (approximately 60 rpm) for about fifteen seconds to combine the dry ingredients. Water was slowly added to the mixing bowl and the materials were mixed for one minute at Speed 1. Mortars made with lime putty were mixed with lime water, whereas mortars made with natural hydraulic lime or Portland cement were mixed with deionized water. The mixer was briefly stopped after one minute and the sides and bottom of the bowl scraped with a palette knife. Mixing recommenced for a total of five minutes, followed by



Figure 3.1. Hobart Mixer C-100

a workability test of the mortar performed by scooping mortar onto a trowel, inverting it, and noting whether the mortar remained on the inverted trowel. The time of mixing, laboratory temperature, and relative humidity were noted following mixing.

Each test was performed immediately after mixing. Consistency was the first test performed on multiple batches of the mortars to determine the appropriate proportion of mix water. Once this proportion was established, water retention, bleeding, and set time tests were performed on all mortars; consistency tests were performed following each test to ensure consistency between mortar batches. Shrinkage tests were performed only on lime putty mortars due to time constraints.

3.4 Consistency

3.4.1 Methodology

The consistency of multiple mortar batches was tested to ascertain the optimum amount of mix water to use with each formulation. Approximately 0.8 L of mortar was mixed in each batch, and three tests were performed per batch to provide a statistical mean. The mortar was tested according to a modified version of the EN 1015-3: 1995 E.

A modified flow table was replicated from specifications developed by J. Dossett⁷ and the flow table specifications in EN 1015-3. The modified flow table (Figures 3.2 and 3.3) was constructed of a piece of plywood 90,000 mm² (139.49 in.²) and 1.8 mm (0.75 in.) in height covered by a 6.35 mm (0.25 in.) thick piece of Plexiglas. A piece of white paper indicating the location and size of the mold was placed between the plywood and the Plexiglas. A threaded pipe 1 in. (25.4 mm) in diameter by 5 in. (127 mm) in length in diameter was screwed into a 1 in. (25.4 mm) threaded flange. This flange was attached to the bottom of the plywood table. A hole was cut approximately 4 in. (101.6 mm) from

⁷ James W. Dossett, "Composite Repair of Sandstone" (master's thesis, University of Pennsylvania, 1998), 36-37.

Figure 3.2.
Modified Flow
Table

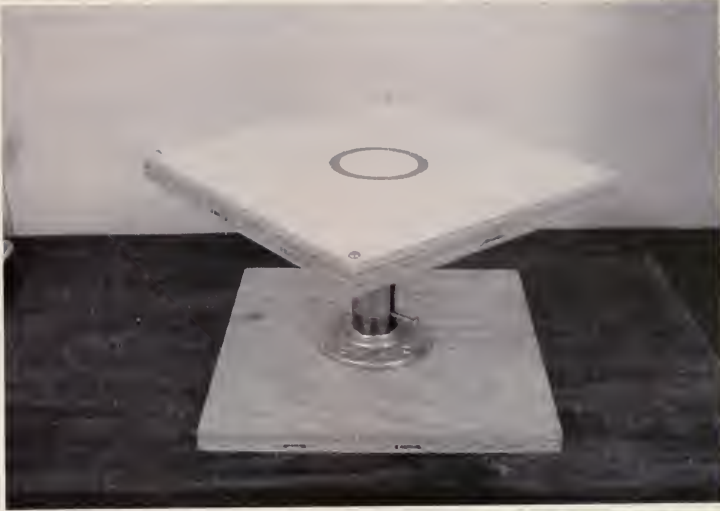

Figure 3.3. Detail of Modified Flow Table

the top end of the pipe to accommodate the lifting handle—a threaded bolt. The base support of the flow table is a similar piece of plywood. A 4 in. (101.6 mm) cut was made through the length of a threaded pipe 1.25 in. (31.75 mm) in diameter and 5 in. (127 mm) in length. This pipe was screwed into a threaded flange 1.25 in. (31.75 mm) in diameter attached to the lower piece of plywood. The smaller pipe was fit into the larger pipe and the holes aligned before inserting the lifting bolt. A hose clamp was placed on the top of the larger pipe to regulate the height of the flow table movement to 80 mm (3.15 in.).

The mold used for the apparatus was a standard Vicat mold, which is put on the center of the flow table. The mortar was placed in the mold in two layers, the first layer being tamped ten times and the final layer tamped twenty times. Excess mortar was removed by two swift cuts of the trowel and the surface of the flow table was cleaned. Approximately fifteen seconds after molding, the mold was removed and the table lifted fifteen times at a rate of approximately one drop per second. The diameter of the flow mortar was measured in right angles to a precision of 0.001 in. (0.025 mm) with Brown & Sharpe Dial-Cal® Dial Calipers (Inch Model 599-579-4).

3.4.2 *Materials*

Mortar made with lime putty will vary in water content due to the storage of lime putty under water; this variability will increase with changes in temperature and relative humidity. The temperature of the laboratory did not vary more than 1°F (0.56°C)—the laboratory temperature was between 68.2 and 69.1°F (20.1 and 20.6°C)—and the relative humidity remained between 32% and 33% during bedding mortar consistency tests on lime putty. Therefore, the major variability with the lime putty used for this study was its proximity to lime water in the storage container and its shaking during transportation from Cairo. Attempts were made to even out the water content of the sample by extracting both wet lime putty in contact with the lime water as well as dry lime

putty from the bottom of the container. Despite these efforts, some batches contained extremely wet lime putty, while others had moderately dry lime putty.

The natural hydraulic lime or Portland cement did not have the same compositional variability as the lime putty and therefore had relatively even flow measurements. During testing of the natural hydraulic lime, the laboratory temperature fluctuated by approximately 1°F (0.56 °C) and remained nearly constant during the consistency tests on Portland cement; the relative humidity of the laboratory was uniform (32%) during consistency tests of both of these materials. The natural hydraulic lime and Portland cement were not mixed at room temperature; rather, they were stored in a sealed container outdoors (on the balcony of the ACL) at approximately 40°F (4.4 °C) and were introduced into the laboratory minutes before mixing. The remaining materials were stored at room temperature, including the deionized water which was prepared twenty-four hours in advance of mixing.

3.4.3 Results of Consistency Tests

Consistency tests were performed on mortars mixed with varying quantities of mix water; the flow rates of these batches were tested to determine the optimal proportion of mix water for each mortar formulation. A simple inverted trowel test was performed after mixing each batch to determine workability. Mortars with an optimal consistency remained on the inverted trowel and had a flow measurement between 0.5 and 2.0 in. (12.7 and 50.8 mm).

3.4.3.1 Lime Putty Mortars

Consistency tests were performed on lime putty mortar mixed with 0.2, 0.25, 0.3, 0.325, and 0.375 parts lime water (by volume). The latter mortar batch exceeded the range of the calipers when dropped on the flow table, and therefore was discarded.

Conversely, the lowest water proportion—0.2 parts lime water—contained too little water and disintegrated after only ten drops on the flow table. The middle proportions—0.25 parts, 0.3 parts, and 0.325 parts lime water—provided inconsistent results due to the lime putty’s variable water content. The lime putty used for the formulation with 0.3 parts water was exceedingly wet. This mortar measured a greater flow than the lime putty mortar with 0.325 parts water, which was mixed with moderately dry lime putty. The lime putty used for the formulation with 0.25 parts lime water was moderately wet, and provided the lowest measurement. As this formulation had the highest consistency (a low flow measurement) and remained on the inverted trowel, it was used for further testing. Table 3.4 shows the results of each consistency test.

Table 3.4. Consistency Tests—1 Lime Putty: 0.5 Brick Dust: 2.5 Sand

Proportion of Lime Water	Average Difference Between Mold and Diameter 1 (in.)	Average Difference Between Mold and Diameter 2 (in.)	Average Difference between Mold and Flow Mortar (in.)	Percent Increase Between Mold and Flow Mortar	Notes
0.200	n/a	n/a	n/a	n/a	sheared after 10 drops
0.250⁸	1.224	1.293	1.259	46.12%	moderately wet lime putty
0.300	2.671	2.750	2.711	99.30%	very wet lime putty
0.325	1.879	1.907	1.893	69.34%	moderately dry lime putty
0.375	beyond 4.000	beyond 4.000	n/a	n/a	beyond measurement of calipers

3.4.3.2 Natural Hydraulic Lime Mortar

Batches of bedding mortar made with natural hydraulic lime were mixed with 0.65, 0.7, and 0.75 parts deionized water (by volume). The consistency measurements

⁸ Formulations in bold indicate optimal mix water proportions for future laboratory testing.

increased nearly proportionally to increased deionized water content (see Graph 3.2).

Graph 3.2. Proportion of Deionized Water to Consistency Measurement for Bedding Mortar with Natural Hydraulic Lime

Bedding Mortar Consistency--Natural Hydraulic Lime

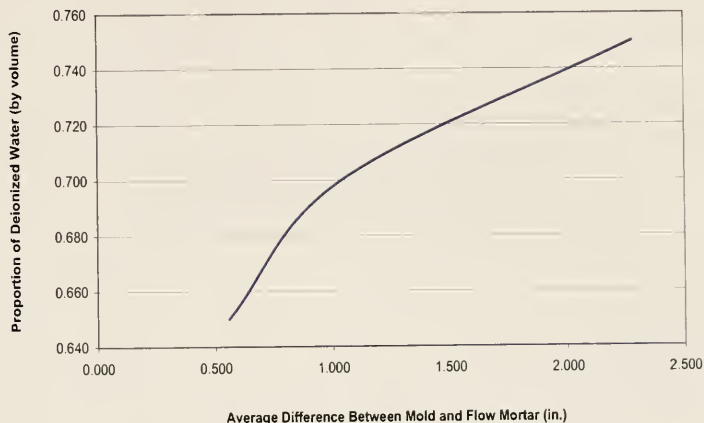

Natural hydraulic lime mortar mixed with 0.7 parts deionized water remained on the inverted trowel and produced a difference in flow measurement approximately 1 in. (25.4 mm) beyond the mold. This proportion was determined to have the most appropriate consistency. Table 3.5 provides the results of consistency tests on natural hydraulic lime.

Table 3.5. Consistency Tests—1 Natural Hydraulic Lime: 0.5 Brick Dust: 2.5 Sand

Proportion of Deionized Water	Average Difference Between Mold and Diameter 1 (in.)	Average Difference Between Mold and Diameter 2 (in.)	Average Difference between Mold and Flow Mortar (in.)	Percent Increase Between Mold and Flow Mortar
0.650	0.545	0.570	0.558	20.42%
0.700	1.064	1.014	1.039	38.06%
0.750	2.287	2.277	2.282	83.59%

3.4.3.3 Portland Cement Mortar

Portland cement mortars require more mix water than natural hydraulic lime mortars. Tests were performed on batches of Portland cement bedding mortar mixed with 0.65, 0.75, 0.8, and 0.85 parts deionized water (by volume). The batch with the lowest amount of mixing water proved insufficiently moist and sheared after only four drops on the flow table. The relationship of flow measurement to proportion of mixing water for Portland cement is not as linear as the natural hydraulic lime binder (see Graph 3.3).

Graph 3.3. Proportion of Deionized Water to Consistency Measurement for Bedding Mortar with Portland Cement

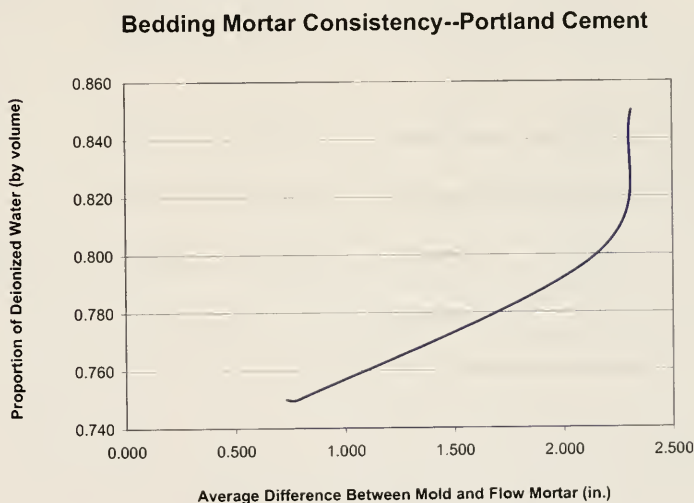

Portland cement mortar mixed with 0.75 parts deionized water produced the lowest flow value measured in the bedding mortar consistency tests—less than 1 in. (25.4 mm) difference between the mold and the flow mortar. There was a steep increase in flow when the water proportion was increased to 0.8 parts, but the flow increase leveled off when 0.85 parts water was added to the mixture. The consistency of the Portland cement bedding mortar with 0.75 parts deionized water was repeated to verify the results of the

first test; the repeated test achieved nearly identical findings to the original consistency trial. This formulation also remained on the inverted trowel in the workability test. Therefore, it was decided that the Portland cement bedding mortar had optimal consistency when mixed with 0.75 parts deionized water. Table 3.6 shows the results of the Portland cement consistency tests.

Table 3.6. Consistency Tests—1 Portland Cement: 0.5 Brick Dust: 2.5 Sand

Proportion of Deionized Water	Average Difference Between Mold and Diameter 1 (in.)	Average Difference Between Mold and Diameter 2 (in.)	Average Difference between Mold and Flow Mortar (in.)	Percent Increase Between Mold and Flow Mortar	Notes
0.650	n/a	n/a	n/a	n/a	sheared after 4 drops
0.750	0.666	0.795	0.731	26.76%	first test at 69.2°F and 32% RH
0.750	0.764	0.803	0.784	28.70%	second test at 72.8°F and 34% RH
0.800	2.118	2.188	2.153	78.86%	
0.850	2.315	2.312	2.314	84.74%	

3.5 Water Retention

3.5.1 Methodology

Water retention tests on the mortar formulations were carried out according to EN 1015-8: 1993 E. Three tests were performed on each type of bedding mortar to provide a statistical mean. Molds were cut from plastic PVC pipe with a 4 in. (101.6 mm) interior diameter and a height of 25 mm (0.98 in.). Eight disks of Whatman 1 filter paper with a 110 mm (4.33 in.) diameter and one disk of cotton gauze approximately 100 mm (0.39 in.) thick were cut to fit the interior diameter of the mold for each test sample. Although EN 1015-8: 1993 E specified the use of two disks of cotton gauze per test, the cotton gauze available for this test had a sufficient thickness. A 0.25 in. (6.35 mm) thick piece

of Plexiglas served as the planar weighing surface, and a 4 in. (101.6 mm) cylindrical diameter watch glass was loaded with glass beads and a 1.5 kg (3.31 lbs.) weight to provide a total compressive weight of 2 kg (4.41 lbs.). The mold, filter papers, cotton gauze, and Plexiglas were all weighed prior to the start of the test (Figure 3.4).

Immediately following mixing, the mortar was placed in the mold with the trowel in approximately ten to twelve strokes. The mortar was lightly compressed with the trowel to assure complete filling of the mold. Excess mortar was removed with a horizontal strike of the trowel, and the mortar, mold, and Plexiglas were weighed. The cotton gauze and filter paper were applied to the surface of the mortar, respectively, and the mold was inverted onto a glass plate. The weighted watch glass was placed on top of the mortar and left for a period of five minutes after which the weight was removed, the mold inverted, and the gauze and filter paper weighed.

A fourth mold was filled with mortar and placed in the oven to dry at 75°C (167°F) for twenty-four hours to determine the water content of the mortar. Additionally,

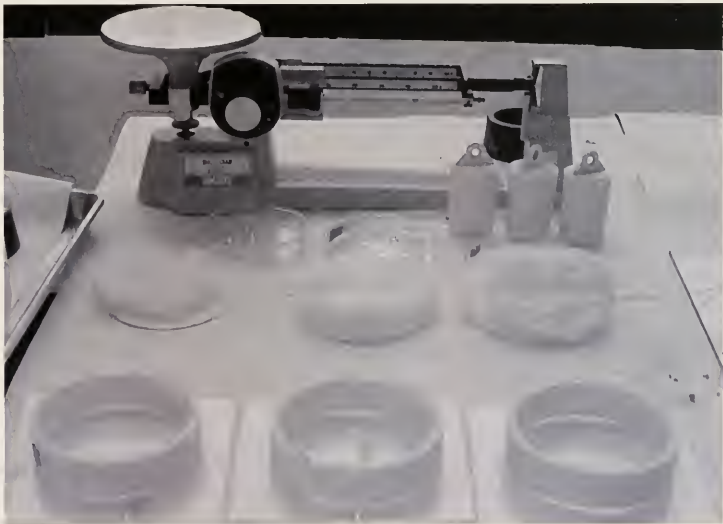

Figure 3.4. Water Retention Test Set Up

each mortar was subjected to a consistency test to verify that the mortar batches were consistent.

3.5.2 Materials

Lime has high water retention, with hydrated lime retaining more mix water than lime putty.⁹ Lime putty has a naturally high water content due to its storage under water, and its water retention capability increases with prolonged storage under water.¹⁰ Portland cement requires more mix water than natural hydraulic lime or lime putty, but is typically characterized by high water retention.¹¹

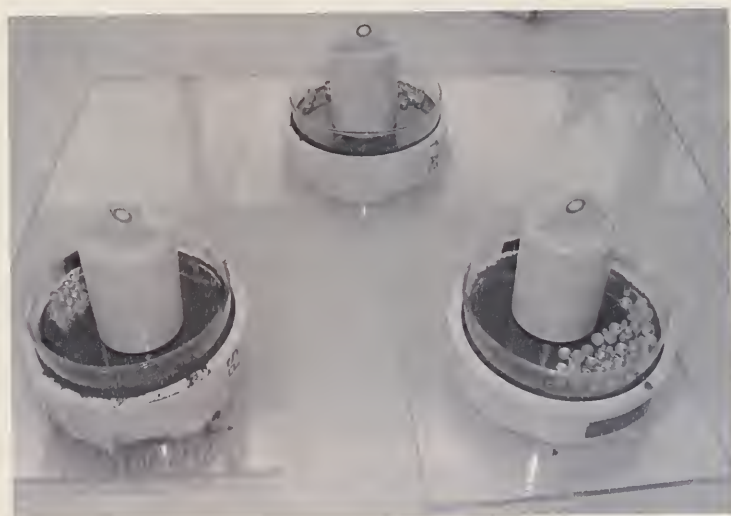

Figure 3.5. Water Retention Test in Progress

⁹ Margaret L. Thompson, "Plasticity, Water Retention, Soundness and Sand Carrying Capacity: What a Mortar Needs," in *International RILEM Workshop on Historic Mortars: Characteristics and Tests* (Paisley, Scotland: RILEM Publications S.A.R.L., 1999): 166.

¹⁰ Hansen et al., "Effects of Ageing on Lime Putty," 201.

¹¹ J.I. Davison, "Masonry Mortar," *Canadian Building Digest* no. 163 (1974): 163-2.

3.5.3 Results of Water Retention Tests

The optimal proportion of mix water was determined in the consistency tests described above. The mortar formulations tested for water retention were those with the best consistency, as indicated in Section 3.4.

3.5.3.1 Lime Putty Mortars

The lime putty mortar used in the water retention test contained approximately 19% water and retained approximately 95.5% of its moisture. This was determined by drying a known amount of molded mortar in an oven for forty-eight hours and measuring the change in mass. Table 3.7 shows the water retention of lime putty mortar used for bedding repairs.

Table 3.7. Water Retention—1 Lime Putty: 0.5 Brick Dust: 2.5 Sand

	Mass of water absorbed by filter paper and gauze (g)	Percentage of water in mortar mixture (based on drying)	mass of water in mortar in mold (g)	percentage of water in mortar after suction
Test 1	3.49	19%	69.59	94.99%
Test 2	2.94	19%	73.77	96.01%
Test 3	2.78	19%	69.69	96.01%

3.5.3.2 Natural Hydraulic Lime Mortar

The natural hydrated lime bedding mortar formulation had a water content of 12% and retained approximately 94% of its moisture. Table 3.8 shows the water retention of natural hydraulic lime mortar.

Table 3.8. Water Retention—1 Natural Hydraulic Lime: 0.5 Brick Dust: 2.5 Sand

	mass of water absorbed by filter paper/ gauze (g)	% water in mortar (based on drying)	mass of water in mortar in mold (g)	percentage of water in mortar after suction
Test 1	2.34	12%	43.91	94.67%
Test 2	2.66	12%	44.32	94.00%
Test 3	2.80	12%	43.39	93.55%

3.5.3.3 Portland Cement Mortar

The Portland cement mortar tested for bedding repair had a water content of 10% and retained about 99% of its moisture. Table 3.9 shows the water retention of the Portland cement mortar.

Table 3.9. Water Retention—1 Portland Cement: 0.5 Brick Dust: 2.5 Sand

	mass of water absorbed by filter paper and gauze (g)	% water in mortar (based on drying)	mass of water in mortar in mold (g)	% water in mortar after suction
Test 1	0.43	10%	37.16	98.84%
Test 2	0.32	10%	36.39	99.12%
Test 3	0.36	10%	35.70	98.99%

3.6 Bleeding

3.6.1 Methodology

Bleeding tests were performed on five samples from each mortar formulation. The tests were based on the RILEM MR-6 recommendations, but modified for ease in measurement. Following mixing, 500 mL of the mortar was spooned into five beakers. The mortar was cut with a trowel to remove entrained air and to fill the beaker with mortar without compressing the sample. The surface of the mortar was smoothed with the trowel into a dome-like shape to ease the collection of bleed water (Figure 3.6). Each beaker was covered with a watch glass and the bleed water was poured into 10 mL

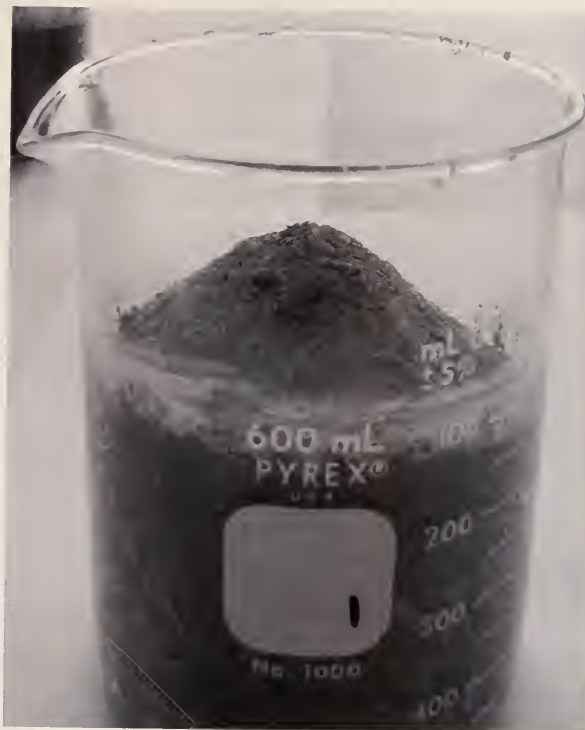

Figure 3.6. Domed Surface of Mortar Sample for Water Retention Test



Figure 3.7. Water Retention Test in Progress

graduated cylinders fifteen minutes, thirty minutes, one hour, two hours, and four hours after the mortars were smoothed (Figure 3.7). The elapsed time, laboratory temperature, and relative humidity were recorded during each measurement.

3.6.2 *Materials*

The bleeding of mortars is effected by the porosity of the stone or brick on which it is applied. Lime putty has a relatively high bleeding rate due to the high water content of the material. Moderate bleeding is not a significant threat to lime mortar as this property will increase the bond strength between the mortar and substrate. Lime physically bonds to the substrate when water evaporates from the mortar. This increases adhesive strength due to migration of colloidal particles by suction of the substrate. Excess water in the lime mortar must be absorbed by the masonry unit to improve the adhesion of the mortar. Conversely, bleeding is a significant problem for Portland cement. Portland cement undergoes a chemical reaction when water evaporates from the mortar. The calcium silicate in Portland cement is transformed into ettringite during drying, giving the binder low bleeding rates. Over time, however, fresh water from precipitation leaches the alkali hydroxides, alkali earth hydroxides, and salts from the cement and could eventually deteriorate the cement structure.¹²

3.6.3 *Results of Bleeding Tests*

The optimal proportion of mix water was determined in the consistency tests described above. The mortar formulations tested for bleeding were those with the best consistency as indicated in Section 3.4.

¹² H.F.W. Taylor, *Cement Chemistry* (London: Academic Press, 1990): 403-404.

3.6.3.1 Lime Putty Mortar

Tests on the bedding mortar made with lime putty show that lime putty bleeds at a consistent rate until it has cured for two hours, at which time the bleeding slows to a level rate. Graph 3.4 shows the bleeding rate of the five tests performed on lime putty mortars, and Graph 3.5 shows the cumulative rate bleeding over time.

3.6.3.2 Natural Hydraulic Lime Mortar

Bleeding tests performed on the natural hydraulic lime bedding mortar showed comparable bleeding with that of the lime putty mortar. Unlike the lime putty mortar, the bleeding rate of the natural hydraulic lime mortar begins to taper approximately 180 minutes from mixing. Graph 3.6 shows the bleeding rate of five natural hydraulic lime tests, and Graph 3.7 shows the cumulative bleeding rate over time.

3.6.3.3 Portland Cement Mortar

Results of the bleeding tests for bedding mortar indicate that the Portland cement mortar bleeds at a comparable rate and quantity as the lime-based mortars. The important exception is that Portland cement mortars produced no bleed water at the four hour measurement interval because they had already begun to set. Graphs 3.8 and 3.9 provide the results for bleeding tests on Portland cement mortars.

Graph 3.4. Bleeding Rate—1 Lime Putty: 0.5 Brick Dust: 2.5 Sand

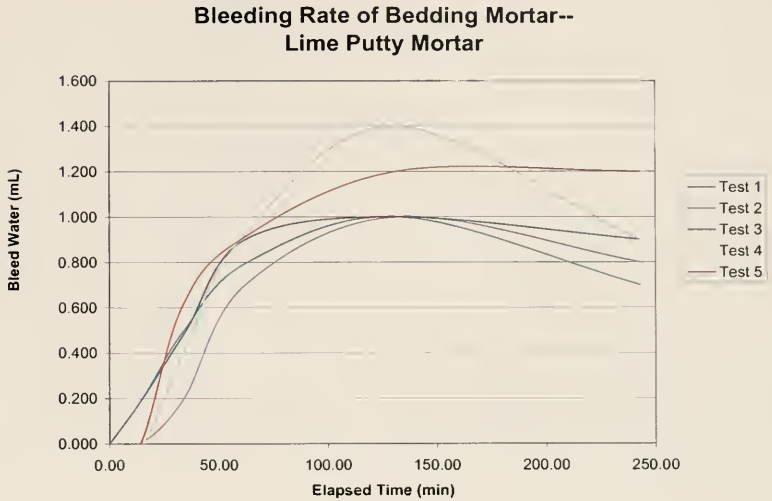

Graph 3.5. Cumulative Bleed Water Rate Over Time—1 Lime Putty: 0.5 Brick Dust: 2.5 Sand

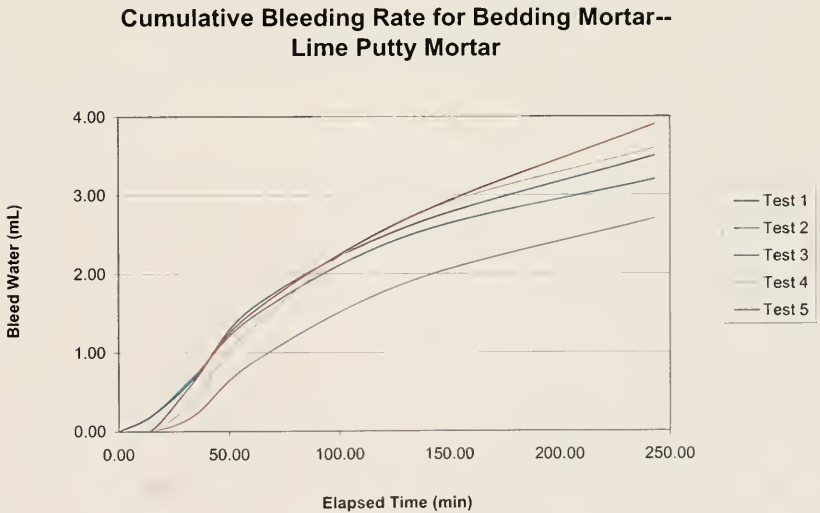

Graph 3.6. Bleeding Rate—1 Natural Hydraulic Lime: 0.5 Brick Dust: 2.5 Sand

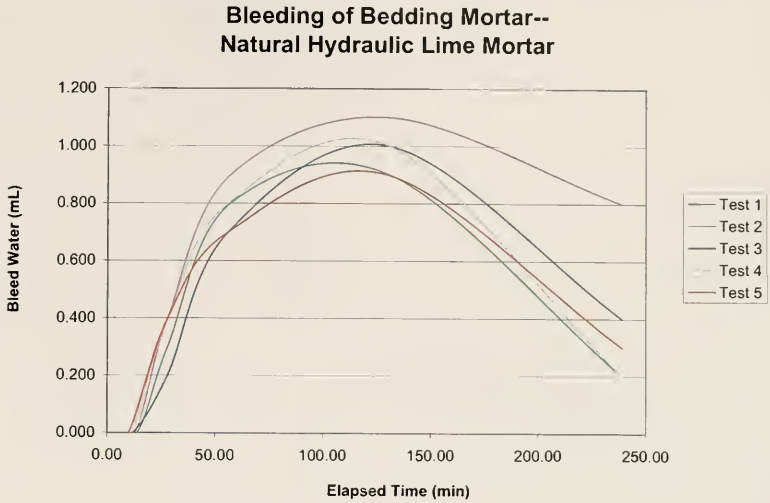

Graph 3.7. Cumulative Bleed Water Rate Over Time—1 Natural Hydraulic Lime: 0.5 Brick Dust: 2.5 Sand

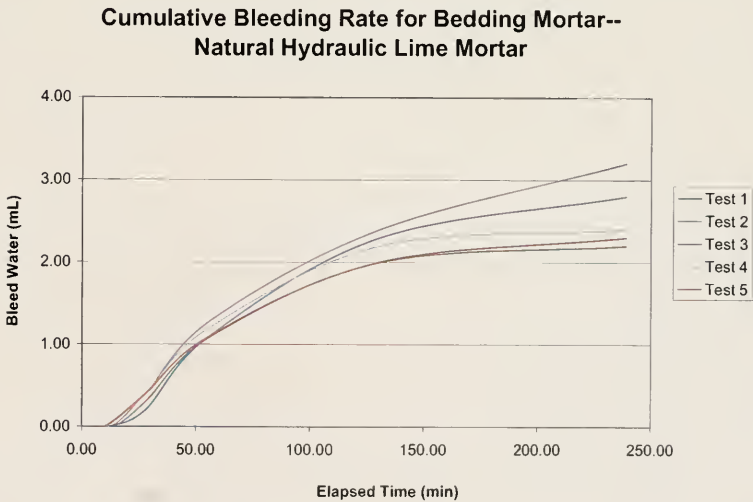

Graph 3.8. Bleeding Rate—1 Portland Cement: 0.5 Brick Dust: 2.5 Sand

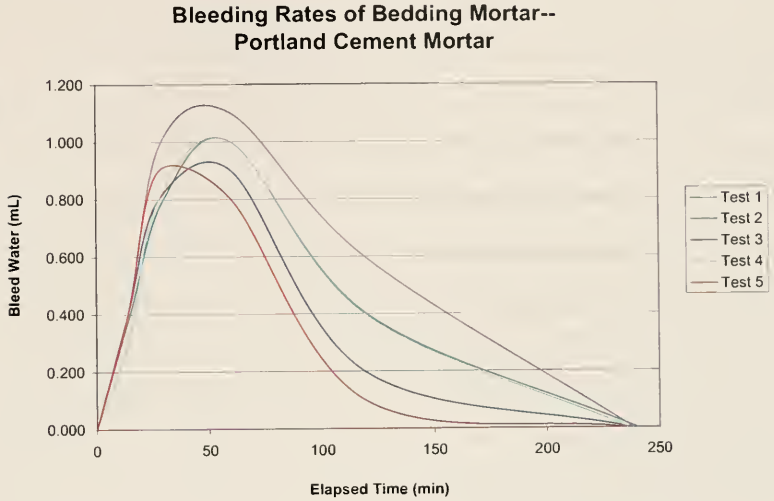

Graph 3.9. Cumulative Bleed Water Rate Over Time—1 Portland Cement: 0.5 Brick Dust: 2.5 Sand

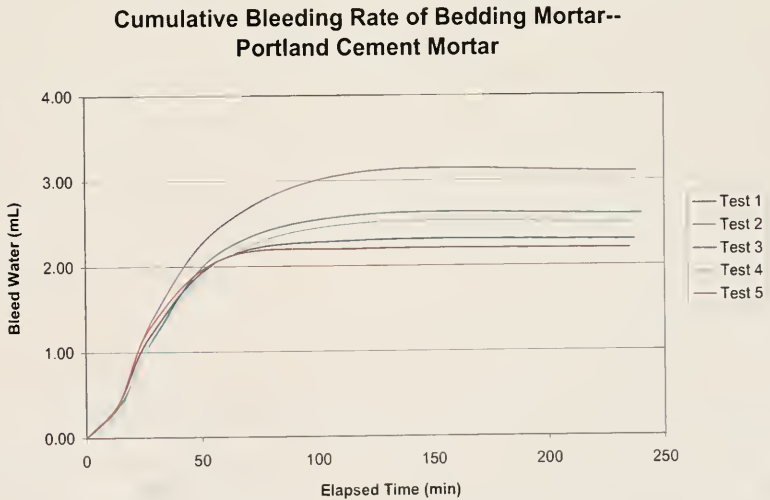

3.7 Set Time

3.7.1 Methodology

Set time tests were performed on three samples from each mortar formulation and were completed over a period of two weeks. The tests were based on a modified form of ASTM C 191-92. The relative humidity of the storage chamber was decreased from the standard 90% to 50%, a more appropriate humidity level for testing the set of lime putty mortars. The between penetration tests was also extended to accommodate the long set time of lime putty mortars. After mixing, the mortar was scooped by hand into three balls about the size of a baseball, which were tossed six times at a distance of approximately 6 in. (152.4 mm). The ball was inserted into the larger end of a Vicat mold that had been lubricated with mineral oil, and excess mortar was removed by a horizontal motion of the hand. The mold was inverted onto a weighing boat with the larger end facing upward, and excess mortar was removed with a palette knife. The surface of the mortar was smoothed by hand to provide a uniform surface for testing. Each sample was immediately tested with the Vicat apparatus and placed in the storage container kept at 50% relative humidity. Penetration tests were performed every hour for the Portland cement mortars; every hour for the natural hydraulic lime after curing in the storage container for three hours; and every twenty-four hours for the first forty-eight hours and every hour, or more frequently as needed, for the lime putty mortars. The time of measurement, elapsed time, penetration, and relative humidity of the storage chamber were measured with each test.

3.7.2 Materials

The setting of mortar occurs when moisture has evaporated from the mixture and the mortar has gained sufficient strength to withstand penetration tests. Set time is effected by the relative humidity and temperature of the curing environment, and varies

between different mortar binders. The set time of lime putty mortar will be lengthened by the addition of a pozzolanic component to the mortar, such as brick dust.

Lime putty mortars take longer to set than mortars consisting of hydraulic lime or Portland cement. Mortars based on lime putty can take several days or weeks to set, depending on the atmospheric conditions. As previously mentioned, lime reacts physically when water is evaporated from the mortar mixture. When a pozzolanic component is introduced into a lime putty mortar, the binder reacts chemically to the pozzolana to speed up the setting rate and to increase the strength of the mortar.

The natural hydraulic lime used in this thesis contains both hydrated lime (calcium hydroxide— $\text{Ca}[\text{OH}]_2$) and a hydraulic component (calcium disilicate— Ca_2SiO_4), which allows the mortar to set in moist conditions or under water and hastens the set time of the lime binder. Hydraulic lime mortars typically take six to twelve hours to set.¹³

Portland cement goes through a chemical transformation as water evaporates from the mixture, and ettringite is formed in the mortar matrix. This material is extremely strong and allows the Portland cement to rapidly set. Portland cement also contains calcium trisilicate (Ca_3SiO_5), an hydraulic component that reacts more quickly than calcium disilicate (Ca_2SiO_4) to allow the cement mortar to set in moist conditions or under water. Portland cement mortars commonly set within a few hours after molding.

3.7.3 Results of Set Time Tests

The optimal proportion of mix water was determined in the consistency tests described above. The mortar formulations tested for set time were those with the best consistency as indicated in Section 3.4.

¹³ Peter T. Ellison, "Hydraulic Lime Mortars" (master's thesis, University of Pennsylvania, 1998), 7.

3.7.3.1 Lime Putty Mortar

The bedding mortar made with lime putty set approximately forty-eight hours after molding. Graph 3.10 shows that the mortar began to set after twenty-four hours, and at thirty-six hours there was a great deal of differential set within each mold.

3.7.3.2 Natural Hydraulic Lime Mortar

The natural hydraulic lime bedding mortar set approximately nine and one half hours after molding. The mortar began setting after about five hours and showed some differential setting towards the end of the test. Graph 3.11 shows the set time of natural hydraulic lime mortars used for bedding repair.

3.7.3.3 Portland Cement Mortar

The Portland cement bedding mortar rapidly set and was characterized by some differential setting during the last hour of the test. The mortar began to set about one hour after molding and was fully set approximately four hours after molding. Graph 3.12 shows the set time of bedding mortar made with Portland cement.

Graph 3.10 Set Time—1 Lime Putty: 0.5 Brick Dust: 2.5 Sand

Set Time--Lime Putty Mortar

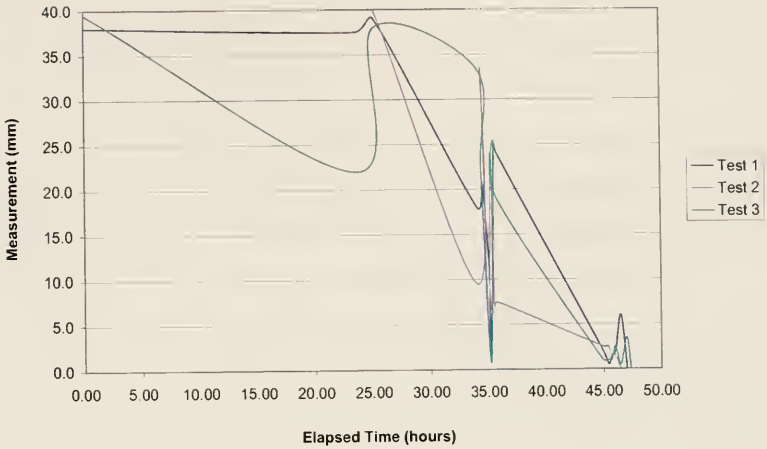

Graph 3.11 Set Time—1 Natural Hydraulic Lime: 0.5 Brick Dust: 2.5 Sand

Set Time--Natural Hydraulic Lime Mortar

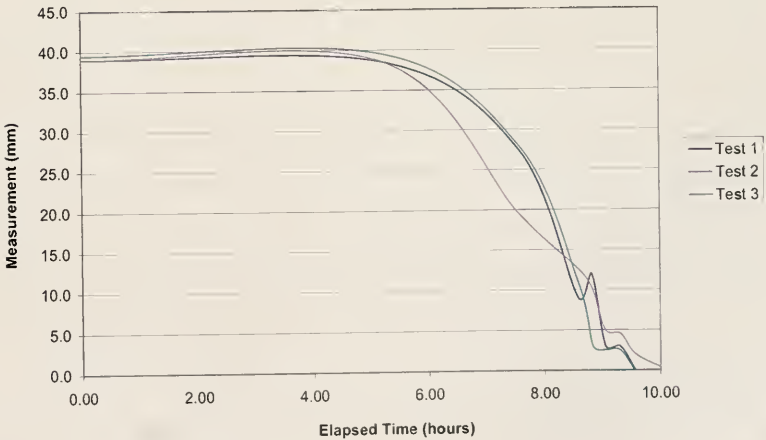

Graph 3.12 Set Time—1 Portland Cement: 0.5 Brick Dust: 2.5 Sand

Set Time--Portland Cement Mortar

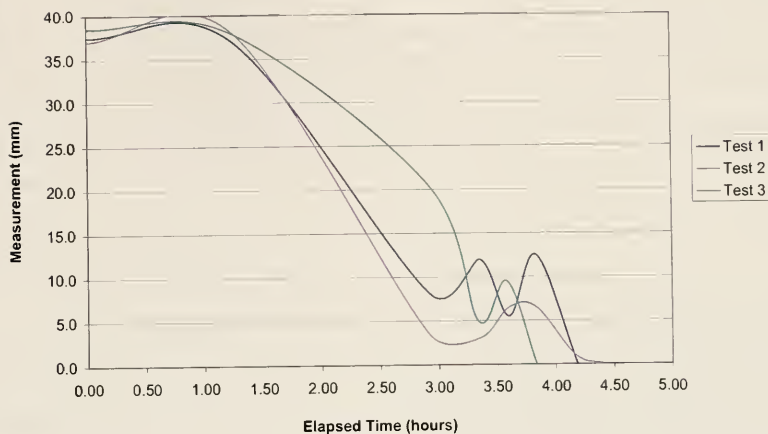

3.8 Shrinkage

3.8.1 Methodology

Shrinkage tests were performed on the lime putty bedding mortar, and tested based on ASTM C 1148-92 (1997). The rectangular steel mold was evenly lubricated with mineral oil prior to the start of the test. Following mixing, the mortar was placed in the mold in two layers, each layer being tamped ten times. Excess mortar was removed with a palette knife, and the surface of the mortar was smoothed prior to placing in the storage chamber. The chamber had an approximate relative humidity of 50%. The molded mortar remained in the storage chamber for seventy-two hours to ensure sufficient setting, and the mortar was removed from the mold.

Lime putty mortars have low initial compressive and flexural strength after one week of curing, and gain low-to-moderate strength after curing for several months.¹⁴

¹⁴ Henriques and Charola, "Standard Test Procedures for Mortars," 1521-1528.

Therefore, it was important to take care in removing lime putty mortars from the shrinkage molds. In de-molding the lime putty mortar samples for shrinkage tests in the current testing program, the sides of the molds were unscrewed and carefully removed from the base. The longitudinal mold dividers were removed and the mortars were evenly lifted from the molds. Despite the care in removing the mortars, they broke apart or crumbled with the slightest motion. Therefore, shrinkage testing for the current thesis was abandoned.

3.8.2 *Alternative Shrinkage Tests*

Alternative shrinkage test methods and de-molding practices were researched for future testing. All shrinkage molds should be sufficiently coated with a release agent with releasing ability superior to mineral oil. Appropriate release agents include petroleum jelly, or a silicon release agent. Lime putty mortars can be removed more efficiently from rectangular prisms by carefully removing the end plates of the mold and slowly applying pressure to the end of the molded mortar. This light pressure will loosen the mortar from the mold's base plate without exerting flexural stress on the mortar. The mortar must be pushed onto a rigid support that matches the height of the mold's base plate to maintain a planar surface.

An alternative shrinkage test may be performed on samples that are wider and shorter than those made from the standard shrinkage mold. Wider, shorter molds make the sample less prone to breakage than the standard 1 in. (25.4 mm) high, 1 in. (25.4 mm) deep, and 11.25 in. (285.75 mm) long molds. Care still needs to be taken when removing lime putty mortar from smaller molds. The alternative molds should be made of steel to maintain the dimensional stability of the mortars, but some absorbent material such as filter paper should be used in the molding process to reproduce the natural moisture

suction by the masonry substrate.¹⁵ The molds should not restrain the shrinkage of the mortar, and the shrinkage should be measured by calipers rather than the vertical length comparator that is required by the standards. Immediately after molding, the mortars should be stored in a chamber with 50% relative humidity and a laboratory temperature between 20 and 25 °C (68 and 77 °F).

Tests should be performed on nine samples of each mortar. Three of the samples should be placed in the mold as described above; three of the samples should be molded and compressed once; and the final three samples should be molded and compressed twice. The absorbent material should be removed after twenty-four hours, and the mortars should be removed from the molds three days after molding to ensure proper hardening of lime putty mortar. The length change can be measured at any time in the duration of the test—while the mortar is in the mold and after the mortar has been removed from the mold. The test should be performed hourly for the first twelve hours, and then daily for at least one month until measured shrinkage ceases.

As mortar shrinkage is directly related to its workability, a workability test should also be added to this alternative shrinkage test. Workability can be empirically measured by determining the self-healing properties of the mortar. After each shrinkage measurement, the mortar should be scored with the bottom of a V-shaped tool and the self-healing capability of the mortar should be recorded.

¹⁵ Charola and Henriques, “Considerations on Testing Standardization,” 6.

CHAPTER 4—FINISH POINTING MORTAR TESTS

4.1 Introduction

The finish pointing mortar for repairing mortar joints on the wall's surface consists of 3 parts a dry mixture of sands, brick dust, and wood ash, and 1 part high-calcium lime putty. All proportions are measured by volume. Table 4.1 shows the proportions of materials used for the finish pointing mortar repairs.

Table 4.1. Material Proportions for Finish Pointing Mortar

Material	Total Volume	Total Percentage
Binder	1 part	25%
Dry Ingredient Mixture*	3 parts	75%

* The dry ingredient mixture is composed of the following proportions:

Dry Material	Volume Added to DRY MIXTURE	Percentage in DRY MIXTURE	Volume in TOTAL MORTAR FORMULATION
Bani Yousef Sand	30 parts	55.3%	1.66 parts
El Katameia Sand	20 parts	36.9%	1.1 parts
Brick Dust	2 – 3 parts	4.6%	0.14 parts
Wood Ash	1.5 – 2 parts	3.2%	0.1 parts

Tests will be performed according to the standards outlined in Chapter 2, and will be compared to mortars of identical proportions containing natural hydraulic lime, and Portland cement binders.

The materials used to test the performance of the finish pointing mortar include lime putty, brick dust, and wood ash sent from Cairo, as well as Kempf yellow bar sand, Schofield yellow mason sand, Riverton natural hydraulic lime, and Portland cement purchased in Pennsylvania.

4.2 Materials

The finish pointing mortar is made from 1 part binder mixed with 3 parts dry mixture. The mixture consists of 30 parts yellow masonry sand from Bani Yousef, Giza; 20 parts pale brown mason sand from El Katameia; 2 – 3 parts brick dust; and 1.5 – 2

parts wood ash. These materials were combined to match the color and texture of the historic pointing mortar.

The Bani Yousef sand is light yellowish brown to dark yellowish brown in color (matching Munsell 10YR 6/4 to 10 YR 6/6) and is sieved through a #16 ASTM standard sieve to remove particles larger than 1180 μm (0.05 in.) in diameter. Over 84% of the sand grains are between 600 and 300 μm (0.02 and 0.01 in.) in size, and the sand contains 1.6% fine particles below 75 μm (0.003 in.). Table 4.2 shows the particle size distribution of the Bani Yousef sand used in the finish pointing mortar.

Table 4.2. Particle Size Distribution of the Bani Yousef Sand

ASTM Sieve Number	Screen Size (μm)	Mass of container (g)	Mass of container and sample (g)	Mass retained (g)	% Mass retained	% Mass on and above	% Mass passing
8	2360	6.55	6.55	0.00	0.00	0.00	100.00
16	1180	6.85	6.88	0.00	0.00	0.00	100.00
30	600	6.69	50.88	44.19	39.30	39.30	60.70
50	300	6.80	57.98	51.18	45.51	84.81	15.19
100	150	6.58	18.50	11.92	10.60	95.41	4.59
200	75	6.64	10.08	3.44	3.06	98.47	1.53
Pan	0	6.68	8.28	1.60	1.42	99.89	0.11

The laboratory analysis of the sand can be found in Appendix A.

The Bani Yousef sand used for the finish pointing mortar was unavailable for use in the current testing program, and was replaced by American sand similar in particle size distribution and mineral content to the sand used in Cairo. The yellow bar sand (purchased from George F. Kempf Building Materials Supply Company in Philadelphia) has a comparable grain size distribution to the Bani Yousef sand when sieved through a #16 ASTM standard sieve. This sand contains over 83% of its mass between 600 and 300 μm (0.02 and 0.01 in.) in size, but has less than one percent fine particles below 75 μm (0.003 in.). Table 4.3 shows the particle grain size distribution of the Kempf yellow concrete sand used in laboratory testing of the bedding mortar.

Table 4.3. Particle Size Distribution of the Kempf Yellow Bar Sand

ASTM Sieve Number	Screen size (µm)	Mass of container (g)	Mass of sample & container (g)	Mass retained (g)	Percent mass retained	Percent on or above	Percent passing
8	2360	7.16	7.16	0.00	0.00	0.00	100.00
16	1180	6.83	6.83	0.00	0.00	0.00	100.00
30	600	7.14	32.05	24.91	21.12	21.12	78.88
50	300	7.29	80.41	73.12	61.98	83.10	16.90
100	150	7.15	24.20	17.05	14.45	97.55	2.45
200	75	7.08	9.35	2.27	1.92	99.47	0.53
Pan	1	7.18	7.80	0.62	0.53	100.00	0.00

X-ray diffraction analysis of the sand can be found in Appendix A.

Graph 4.1 compares the particle size distribution of the Bani Yousef sand used in Cairo with the Kempf Yellow Bar sand used to mix the finish pointing mortar in the current testing program.

Graph 4.1. Particle Size Distribution of Bani Yousef and Kempf Yellow Bar Sands

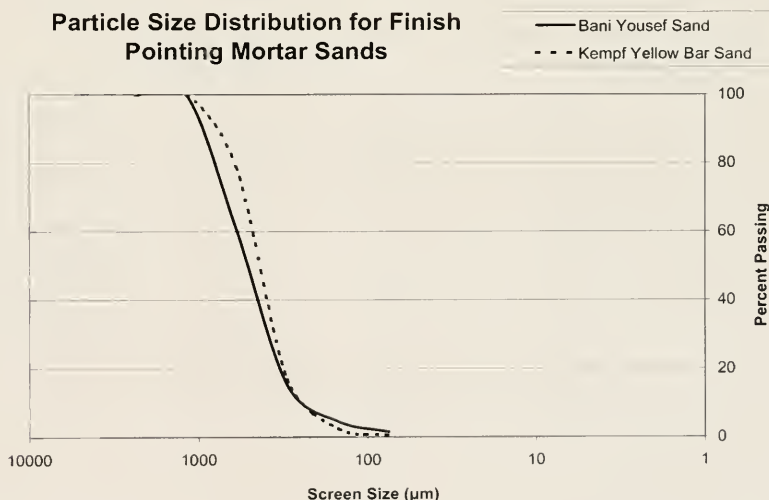

The El Katameia masonry sand used in Cairo for finish pointing mortar is also sieved through a #16 ASTM standard sieve, and is pale brown in color (matching

Munsell: 10YR 8/2). Over 88% of the sand grains are between 600 and 300 μm (0.02 and 0.02 in.) in size, and the sand contains less than one percent fine particles below 75 μm (0.003 in.). Table 4.4 shows the particle size distribution of the El Katameia sand used in the finish pointing mortar.

Table 4.4. Particle Size Distribution of the El Katameia Sand

ASTM Sieve Number	Screen Size (μm)	Mass of container (g)	Mass of container & sample (g)	Mass retained (g)	Percent Mass retained	Percent on and above	Percent passing
8	2360	1.97	1.97	0.00	0.00	0.00	100.00
16	1180	1.97	1.97	0.00	0.00	0.00	100.00
30	600	2.00	11.03	9.03	8.24	8.24	91.76
50	300	1.99	89.45	87.46	79.85	88.09	11.91
100	150	6.56	17.68	11.12	10.15	98.25	1.75
200	75	6.64	8.03	1.39	1.27	99.52	0.48
Pan	0	6.67	7.03	0.36	0.33	99.84	0.16

A microscopic and X-ray diffraction analysis of the sand can be found in Appendix A.

The El Katameia masonry sand was unavailable for the current testing program, and was replaced with a yellow mason sand (purchased from the George Schofield Company in New Jersey). This sand was sieved through a #16 ASTM standard sieve prior to mixing with the mortar components. Over 75% of the sand grains are between 600 and 300 μm (0.02 and 0.02 in.) in size, and the sand contains less than one percent fine particles below 75 μm (0.003 in.). Table 4.5 shows the particle size distribution of the Schofield yellow mason sand.

Table 4.5. Particle Size Distribution of Schofield Yellow Mason Sand

ASTM Sieve Number	Screen size (µm)	Mass of container (g)	Mass of sample & container (g)	Mass retained (g)	Percent mass retained	Percent on or above	Percent passing
8	2360	7.16	7.16	0.00	0.00	0.00	100.00
16	1180	7.12	7.12	0.00	0.00	0.00	100.00
30	600	7.03	27.13	20.10	11.36	11.36	88.64
50	300	7.07	119.91	112.84	63.77	75.12	24.88
100	150	7.22	42.71	35.49	20.06	95.18	4.82
200	75	7.03	10.85	3.82	2.16	97.34	2.66
pan	1	7.05	7.59	0.54	0.31	97.64	2.36

A laboratory analysis of the Schofield yellow mason sand can be found in Appendix A.

Graph 4.2 compares the particle size distribution of the El Katameia sand used in Cairo with the Schofield Yellow Mason sand used to mix the finish pointing mortar in the current testing program.

Graph 4.2. Particle Size Distribution of El Katameia and Schofield Yellow Mason Sands

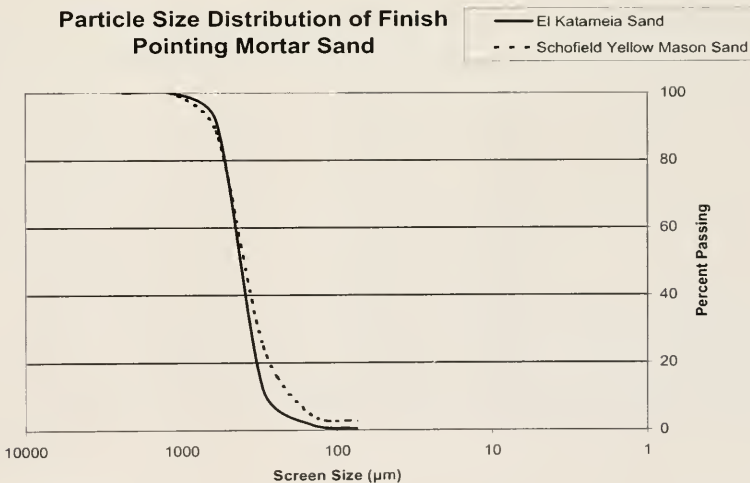

The wood ash used in the dry mixture is produced when wood from Abu El Nomros is incompletely burned to form a fine black powder. The dark gray wood ash

(matching Munsell 5Y 5/1 to 5Y 4/1) is sieved through a #100 ASTM standard sieve to remove pieces of ash larger than 150 μm (0.006 in.). The wood ash provides both water retention for the mortar and visual properties for matching the finish pointing mortar with the historic pointing mortar. A laboratory analysis of the wood ash can be found in Appendix A.

Brick dust used in the finish pointing mortar is produced by finely crushing red bricks from Egyptian demolition projects, and is sieved through a #30 ASTM standard sieve to remove particles larger than 600 μm (0.02 in.) prior to mixing with the sand and lime putty. Brick dust is added to the mortar as a pozzolanic component as discussed in Section 3.2. Appendix A provides a laboratory analysis of the brick dust.

The lime putty used for the Ayyubid wall repairs is highly pure and is discussed in Section 3.2. Data from the laboratory analysis can be found in Appendix A.

In order to compare the performance of the lime putty mortar used to repair the Ayyubid wall, consistency, water retention, bleeding, and set time tests were also performed on two other mortars containing either Riverton natural hydraulic lime or Portland cement. The natural hydraulic lime was purchased from Riverton Corporation in October 2002 by the University of Pennsylvania's Architectural Conservation Laboratory (ACL). The data on this material can be found in Section 3.2. An X-ray diffraction analysis of this material can be found in Appendix A.

Type 1 Portland cement powder is a fine, gray powder produced by Capitol Cement, and is used as a binder in the current testing program. Further information is provided in Section 3.2. An X-ray diffraction analysis of this material can be found in Appendix A.

4.3 Preparation

The mortars were mixed as described in Section 3.3 for a total of five minutes.

The dry mixture and binder were placed in the mixing bowl, respectively, and mixed at Speed 1 (approximately 60 rpm) for about fifteen seconds to combine the ingredients. Water was slowly added to the mixing bowl and the materials were mixed for one minute at Speed 1. Mortars made with lime putty were mixed with lime water, whereas mortars made with natural hydraulic lime or Portland cement were mixed with deionized water. A workability test of the mortar was performed immediately after mixing by scooping mortar onto a trowel, inverting it, and noting whether the mortar remained on the inverted trowel. The time of mixing, laboratory temperature, and relative humidity were noted following mixing.

Each test was performed immediately after mixing. Consistency was the first test performed on multiple batches of the mortars to determine the appropriate proportion of mix water. Once this proportion was established, water retention, bleeding, and set time tests were performed on all mortars; consistency tests were performed following each test to ensure consistency between mortar batches. Shrinkage tests were not performed due to problems mentioned in Section 3.8.1.

4.4 Consistency

4.4.1 Methodology

The consistency of multiple mortar batches was tested to ascertain the optimum amount of mix water to use with each formulation. Approximately 0.8 L of mortar was mixed in each batch, and three tests were performed per batch to provide a statistical mean. The mortar was tested according to a modified version of the EN 1015-3: 1995 E, as described in Section 3.4.1.

4.4.2 Materials

Mortar made with lime putty will vary in water content due to the storage of lime

putty under water; this variability will increase with changes in temperature and relative humidity. The temperature of the laboratory did not vary more than 1°F (0.56°C)—the laboratory temperature was between 71.4 and 72.3°F (20.8 and 22.3°C)—and the relative humidity remained 34% during consistency tests on lime putty finish pointing mortar. Therefore, the major variability with the lime putty used for this study was its proximity to lime water in the storage container and its shaking during transportation from Cairo. Attempts were made to even out the water content of the sample by extracting both wet lime putty in contact with the lime water as well as dry lime putty from the bottom of the container. Despite these efforts, some mortar batches contained extremely wet lime putty, while others had moderately dry lime putty.

The natural hydraulic lime or Portland cement did not have the same compositional variability as the lime putty and therefore had relatively even flow measurements. During testing of the natural hydraulic lime and Portland cement mortars, the laboratory temperature fluctuated by approximately 1°F (0.56 °C) and remained nearly constant during the consistency tests on Portland cement; the relative humidity of the laboratory was uniform (34%) during consistency tests of both of these mortars. The natural hydraulic lime and Portland cement were not mixed at room temperature; rather, they were stored in a sealed container outdoors (on the balcony of the ACL) at approximately 40°F (4.4 °C) and were introduced into the laboratory minutes before mixing. The remaining materials were stored at room temperature, including the deionized water which was prepared twenty-four hours in advance of mixing.

4.4.3 Results of Consistency Tests

The finish pointing mortar consists of 3 parts dry mixture (by volume) to 1 part binder. Consistency tests were performed on mortars mixed with varying quantities of mix water; the flow rates of these batches were tested to determine the optimal proportion

of mix water for each mortar formulation. A simple inverted trowel test was performed after mixing each batch to determine workability. Mortars with an optimal consistency remained on the inverted trowel and had a flow measurement between 0.5 and 2.0 in. (12.7 and 50.8 mm).

4.4.3.1 Lime Putty Mortar

Consistency tests were performed on finish pointing mortar with a lime putty binder mixed with 0.35, 0.4, 0.425, 0.45, and 0.5 parts lime water (by volume). The two batches with the lowest amount of mix water were too dry and sheared almost immediately after the flow test began. The latter two formulations provided nearly identical results, indicating that the water content of the lime putty varied between the tests. The mortar batch with 0.425 parts lime water had a moderate consistency value and remained on the inverted trowel during the workability test. Therefore, this mortar formulation was used for further testing. Table 4.6 shows the results of the consistency tests on the lime putty finish pointing mortar.

Table 4.6. Consistency Tests—1 Lime Putty: 3 Dry Mixture

Proportion of Lime Water	Average Difference Between Mold and Diameter 1 (in.)	Average Difference Between Mold and Diameter 2 (in.)	Average Difference between Mold and Flow Mortar (in.)	Percent Increase Between Mold and Flow Mortar	Notes
0.350	n/a	n/a	n/a	n/a	sheared after 7 drops
0.400	n/a	n/a	n/a	n/a	sheared after 8 drops
0.425¹	1.272	1.338	1.305	47.80%	
0.450	2.498	2.524	2.511	91.98%	
0.500	2.391	2.664	2.528	92.58%	

¹ Formulations in bold indicate optimal mix water proportions for use in further testing.

4.4.3.2 Natural Hydraulic Lime Mortar

Batches of natural hydraulic lime finish pointing mortars were mixed with 0.75, 0.775, and 0.8 parts deionized water (by volume). These values varied immensely, despite nearly identical atmospheric conditions in the laboratory during the three tests; the relative humidity was constant at 34%, while the temperature increased from 69.2°F to 70.8°F (20.67°C to 21.56°C). Table 4.7 shows the variations between flow values, mix water proportions, and laboratory temperatures.

Table 4.7. Consistency Tests—1 Natural Hydraulic Lime: 3 Dry Mixture

Proportion of Deionized Water	Average Difference Between Mold and Diameter 1 (in.)	Average Difference Between Mold and Diameter 2 (in.)	Average Difference between Mold and Flow Mortar (in.)	Percent Increase Between Mold and Flow Mortar	Notes
0.750	2.268	2.403	2.336	85.55%	lab temp: 69.2°F
0.775	1.638	1.823	1.731	63.39%	lab temp: 70.8°F
0.800	2.028	2.100	2.064	75.60%	lab temp: 70.1°F

The natural hydraulic lime mortar mixed with 0.775 parts water remained on the inverted trowel and had a flow measurement in the acceptable range (between 0.5 and 2.0 in. [12.7 and 50.8 mm]). Therefore, this formulation was used for water retention, bleeding, and set time testing.

4.4.3.3 Portland Cement Mortar

Four tests were performed on finish pointing mortars formulations with a Portland cement binder. Batches of mortar with 0.8, 0.85, 0.875, and 0.9 parts deionized water (by volume) were tested for consistency. Mortars with the least amount of water—0.8 parts and 0.85 parts deionized water—sheared before the flow tests were complete. The flow measurement for the Portland cement mortar with 0.875 parts water was within the

acceptable range. Furthermore, this mortar remained on the trowel during the workability test. Therefore, this mortar formulation was selected for use in further testing. Table 4.8 gives the flow values for the Portland cement finish pointing mortar.

Table 4.8. Consistency Tests—1 Portland Cement: 3 Dry Mixture

Proportion of Deionized Water	Average Difference Between Mold and Diameter 1 (in.)	Average Difference Between Mold and Diameter 2 (in.)	Average Difference between Mold and Flow Mortar (in.)	Percent Increase Between Mold and Flow Mortar	Notes
0.800	n/a	n/a	n/a	n/a	sheared after 4 drops
0.850	n/a	n/a	n/a	n/a	sheared after 10 drops
0.875	1.097	1.162	1.130	41.37%	
0.900	2.309	2.329	2.319	84.95%	

4.5 Water Retention

4.5.1 Methodology

Water retention tests on the three mortar formulations were carried out according to EN 1015-8: 1993 E as described in Section 3.5.1. Following the water retention tests, each mortar was subjected to a consistency test to verify that the mortar batches were consistent.

4.5.2 Materials

Lime has high water retention, with hydrated lime retaining more mix water than lime putty.² Lime putty has a naturally high water content due to its storage under water, and its water retention capability increases with prolonged storage under water.³ Portland cement requires more mix water than natural hydraulic lime or lime putty, but is typically

² Thompson, "Plasticity, Water Retention, Soundness and Sand Carrying Capacity," 166.

³ Hansen et al., "Effects of Ageing on Lime Putty," 201.

characterized by high water retention.⁴ The wood ash provides excellent water retention properties to lime mortar due to the hygroscopicity of the ash.⁵

4.5.3 Results of Water Retention Tests

The optimal proportion of mix water was determined in the consistency tests described above. The mortar formulations tested for water retention were those with the best consistency, as indicated in Section 4.4.

4.5.3.1 Lime Putty Mortar

The finish pointing mortar made with lime putty had a high water content of 22% and retained approximately 94.5% of its water. These values are comparable to the lime putty mortar used for bedding repair. Table 4.9 shows the water retentivity of finish pointing mortar made with lime putty.

Table 4.9. Water Retention—I Lime Putty: 3 Dry Mixture

	mass of water absorbed by filter paper and gauze (g)	percentage of water in mortar mixture (based on drying)	mass of water in mortar in mold (g)	percentage of water in mortar after suction
Test 1	5.29	22%	82.06	93.55%
Test 2	4.10	22%	81.18	94.95%
Test 3	3.37	22%	77.56	95.65%

4.5.3.2 Natural Hydraulic Lime Mortar

The finish pointing mortar made with natural hydraulic lime had a water content of 13% and retained over 95% of its water. Table 4.10 shows the water retention of the natural hydraulic lime finish pointing mortar.

⁴ Davison, "Masonry Mortar," 163-2.

⁵ Goodman, "Effects of Wood Ash," 66.

Table 4.10. Water Retention—1 Natural Hydraulic Lime: 3 Dry Mixture

	mass of water absorbed by filter paper and gauze (g)	percentage of water in mortar mixture (based on drying)	mass of water in mortar in mold (g)	percentage of water in mortar after suction
Test 1	3.07	13%	47.57	93.55%
Test 2	1.54	13%	45.09	96.58%
Test 3	1.91	13%	46.07	95.85%

4.5.3.3 Portland Cement Mortar

The Portland cement mortar contained the least amount of water among finish pointing mortars, but retained approximately 97% of its water content. Table 4.11 provides the water retention results for the Portland cement finish pointing mortar.

Table 4.11. Water Retention—1 Portland Cement: 3 Dry Mixture

	mass of water absorbed by filter paper and gauze (g)	percentage of water in mortar mixture (based on drying)	mass of water in mortar in mold (g)	percentage of water in mortar after suction
Test 1	0.76	12%	44.54	98.29%
Test 2	1.32	12%	46.16	97.14%
Test 3	1.44	12%	44.76	96.78%

4.6 Bleeding

4.6.1 Methodology

Bleeding tests were performed on five samples from each mortar formulation. The tests were based on the RILEM MR-6 recommendations, but modified as described in Section 3.6.1.

4.6.2 Materials

The bleeding of mortars is effected by the porosity of the stone or brick on which it is applied. Lime putty has a relatively high bleeding rate due to the high water

content of the material. Moderate bleeding is not a significant threat to lime mortar as this property will increase the bond strength between the mortar and substrate. Lime physically bonds to the substrate when water evaporates from the mortar. This increases adhesive strength due to migration of colloidal particles by suction of the substrate. Excess water in the lime mortar must be absorbed by the masonry unit to improve the adhesion of the mortar. Conversely, bleeding is a significant problem for Portland cement. Portland cement undergoes a chemical reaction when water evaporates from the mortar. The calcium silicate in Portland cement is transformed into ettringite during drying, giving the binder low bleeding rates. Over time, however, fresh water from precipitation leaches the alkali hydroxides, alkali earth hydroxides, and salts from the cement and could eventually deteriorate the cement structure.⁶

4.6.3 Results of Bleeding Tests

The optimal proportion of mix water was determined in the consistency tests described above. The mortar formulations tested for bleeding were those with the best consistency as indicated in Section 4.4.

4.6.3.1 Lime Putty Mortar

The lime putty mortar used for finish pointing had a high rate of bleeding sixty minutes after mixing. The quantity of bleed water produced by the lime putty mortar was higher than that of the other finish pointing mortars. As with the bedding mortar composed of lime putty, the lime putty finish pointing mortar had a high amount of late bleeding, but this began to taper off to a steady rate between one and two hours after mixing. Graph 4.3 shows the bleeding rate of finish pointing mortar made with lime putty and graph 4.4 shows the cumulative bleeding of finish pointing mortar with lime putty.

⁶ Taylor, *Cement Chemistry*, 403-404.

Graph 4.3. Bleeding Rate—1 Lime Putty: 3 Dry Mixture

Bleeding of Finish Pointing Mortar--Lime Putty Mortar

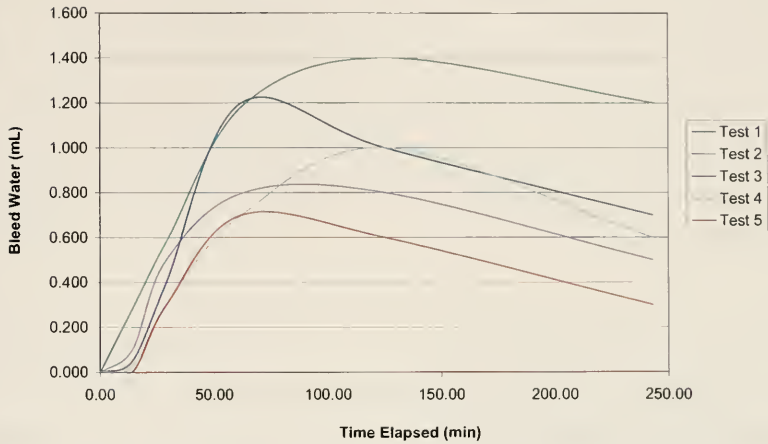

Graph 4.4. Cumulative Bleeding Rate—1 Lime Putty: 3 Dry Mixture

**Cumulative Bleed Rate of Finish Pointing Mortar--
Lime Putty Mortar**

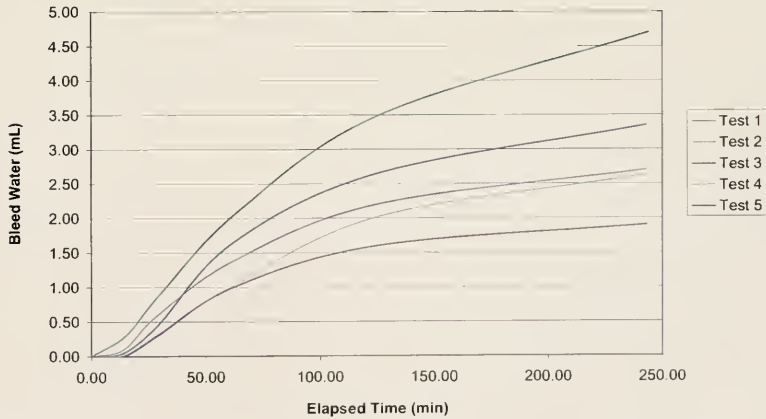

4.6.3.2 Natural Hydraulic Lime Mortar

The natural hydraulic lime mortar used for finish pointing had a significantly smaller amount of bleed water compared to the natural hydraulic lime used for bedding mortar. The bleeding of the natural hydraulic lime finish pointing mortar peaked at two hours and decreased rapidly after this point until there was virtually no bleeding four hours from mixing. Graph 4.5 shows the bleeding rate of finish pointing mortar made with natural hydraulic lime and graph 4.6 shows the cumulative bleeding rate of the mortar.

4.6.3.3 Portland Cement Mortar

The Portland cement mortar used for finish pointing showed variability of bleeding rates. Bleeding peaked one hour after mixing and sharply declined as the mortar began to set. The amount of bleed water was significantly less than the bleeding of Portland cement mortar used for bedding repairs. Graphs 4.7 and 4.8 show the bleeding rate of Portland cement mortar for finish pointing.

Graph 4.5. Bleeding Rate—1 Natural Hydraulic Lime: 3 Dry Mixture

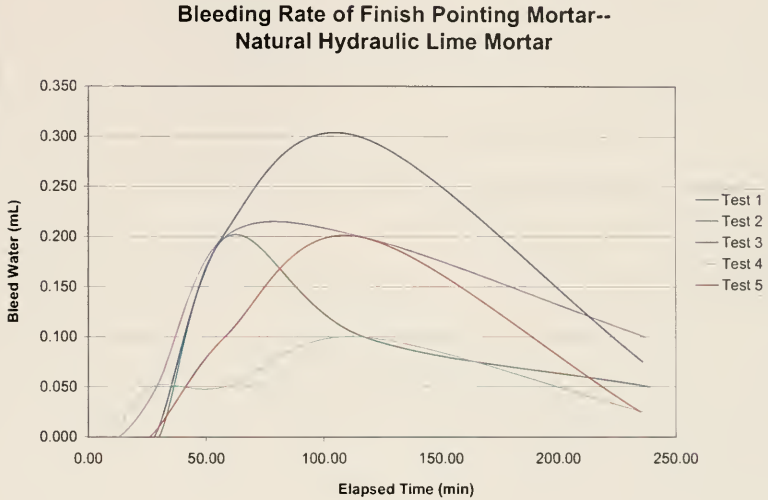

Graph 4.6. Cumulative Bleeding Rate—1 Natural Hydraulic Lime: 3 Dry Mixture

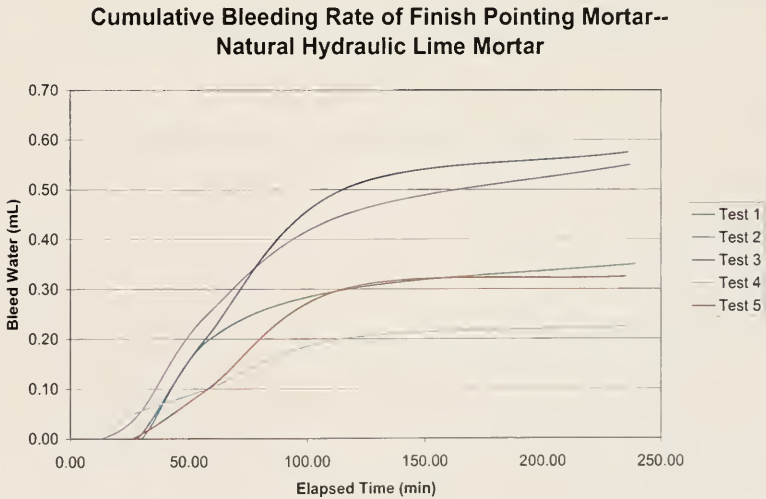

Graph 4.7. Bleeding Rate—1 Portland Cement: 3 Dry Mixture

**Bleeding Rate of Finish Pointing Mortar--
Portland Cement Mortar**

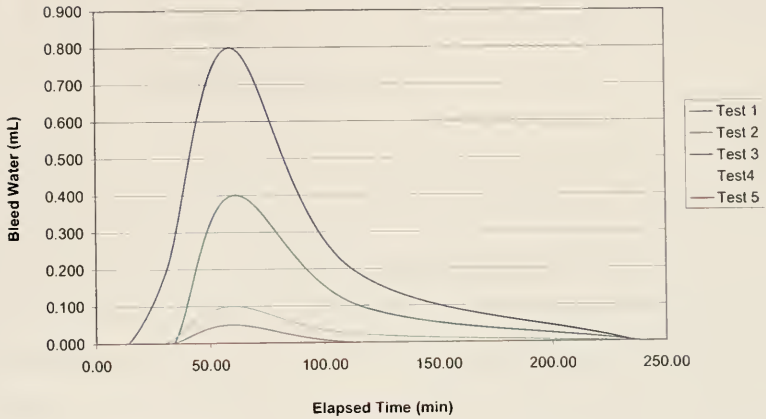

Graph 4.8. Cumulative Bleeding Rate—1 Portland Cement: 3 Dry Mixture

**Cumulative Bleeding Rate for Finish Pointing Mortar--Portland
Cement Mortar**

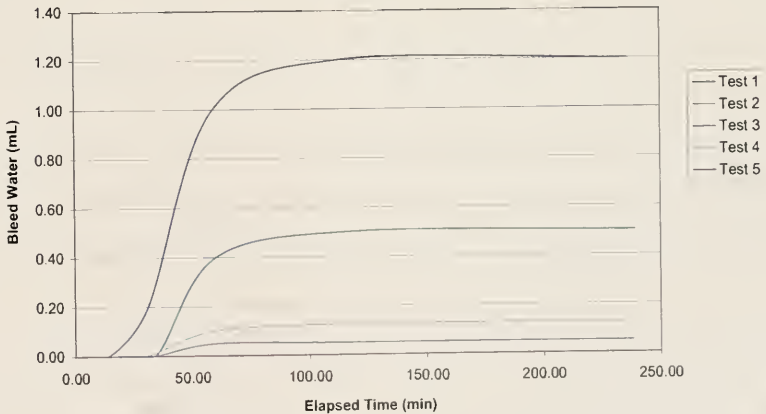

4.7 Set Time

4.7.1 Methodology

Set time tests were performed on three samples from each mortar formulation and were completed over a period of one week. The tests were based on a modified form of ASTM C 191-92 as described in Section 3.7.1.

4.7.2 Materials

The setting of mortar occurs when moisture has evaporated from the mixture and the mortar has gained sufficient strength to withstand penetration tests. Set time is effected by the relative humidity and temperature of the curing environment, and varies between different mortar binders. The set time of lime putty mortar will be lengthened by the addition of a pozzolanic component to the mortar, such as brick dust.

Lime putty mortars take longer to set than mortars consisting of hydraulic lime or Portland cement. Mortars based on lime putty can take several days or weeks to set, depending on the atmospheric conditions. As previously mentioned, lime reacts physically when water is evaporated from the mortar mixture. When a pozzolanic component is introduced into a lime putty mortar, the binder reacts chemically to the pozzolana to speed up the setting rate and to increase the strength of the mortar.

The natural hydraulic lime used in this thesis contains both hydrated lime (calcium hydroxide— $\text{Ca}[\text{OH}]_2$) and a hydraulic component (calcium disilicate— Ca_2SiO_4), which allows the mortar to set in moist conditions or under water and hastens the set time of the lime binder. Hydraulic lime mortars typically take six to twelve hours to set.⁷

Portland cement goes through a chemical transformation as water evaporates from the mixture, and ettringite is formed in the mortar matrix. This material is extremely strong and allows the Portland cement to rapidly set. Portland cement also contains

⁷Ellison, "Hydraulic Lime Mortars," 7.

calcium trisilicate (Ca_3SiO_3), an hydraulic component that reacts more quickly than calcium disilicate (Ca_2SiO_4) to allow the cement mortar to set in moist conditions or under water. Portland cement mortars commonly set within a few hours after molding.

4.7.3 Results of Set Time Tests

The optimal proportion of mix water was determined in the consistency tests described above. The mortar formulations tested for set time were those with the best consistency as indicated in Section 4.4.

4.7.3.1 Lime Putty Mortar

The finish pointing mortar made with lime putty set approximately sixty-five hours after molding. The mortar began to set after about fifty hours in the mold, and set irregularly after that point. One of the test samples (test 3) set in an erratic manner and took longer to fully set than the other two test samples. Therefore, these test data will be omitted from final observations about the set of finish pointing mortar with a lime putty binder. Graph 4.9 shows the set time results for finish pointing mortar made with lime putty.

Graph 4.9. Set Time—1 Lime Putty: 3 Dry Mixture

**Set Time of Finish Pointing Mortar--
Lime Putty Mortar**

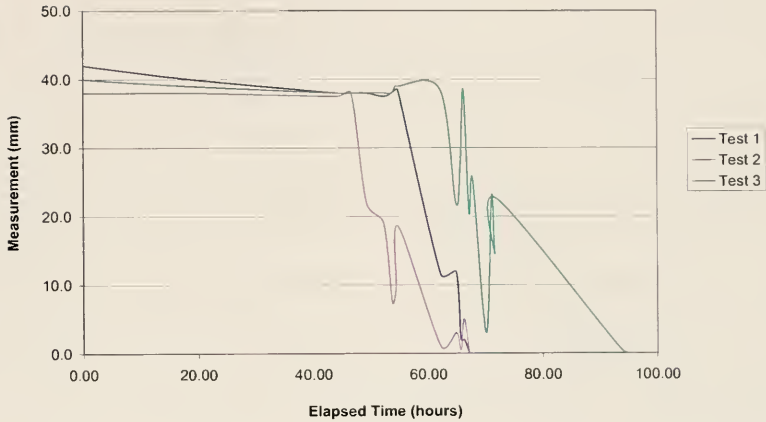

4.7.3.2 Natural Hydraulic Lime Mortar

The natural hydraulic lime mortar for finish pointing repair set in about thirteen hours. The mortar commenced setting approximately eight hours after molding and showed a great deal of differential setting. Graph 4.10 shows the setting rate of natural hydraulic lime finish pointing mortar.

Graph 4.10. Set Time—1 Natural Hydraulic Lime: 3 Dry Mixture

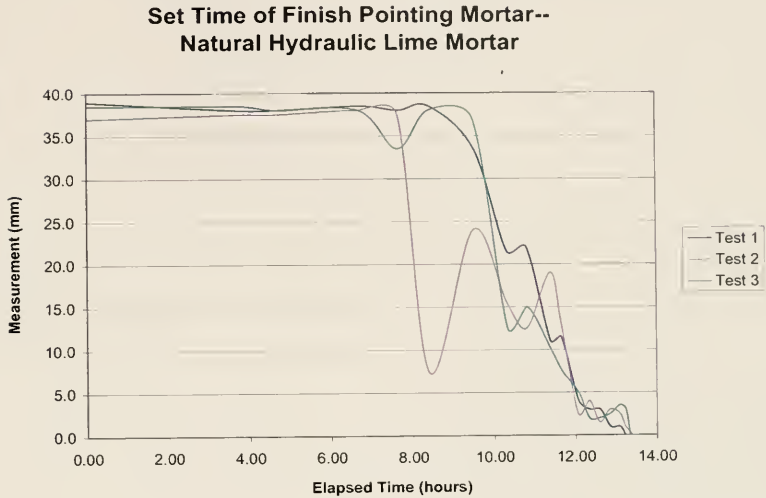

4.7.3.3 Portland Cement Mortar

The Portland cement mortar used for finish pointing set five and one half hours after molding. The mortar began to set after two hours and had a fairly regular setting pattern. Graph 4.11 shows the setting rate of Portland cement mortar used for finish pointing.

Graph 4.11. Set Time—1 Portland Cement: 3 Dry Mixture

Set Time of Finish Pointing Mortar--
Portland Cement Mortar

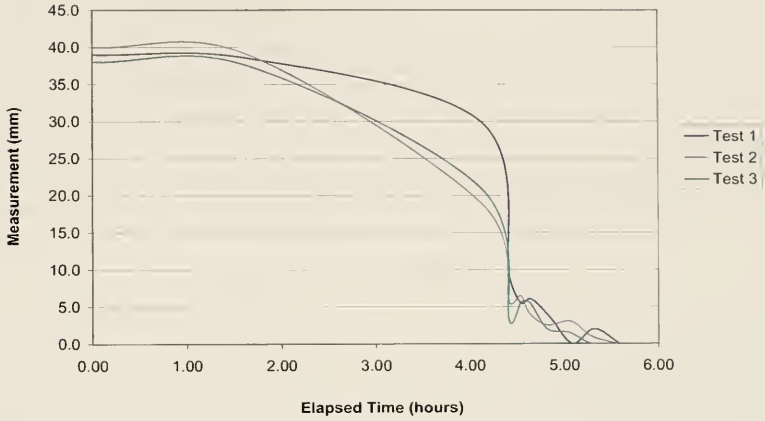

CHAPTER 5—DISCUSSION AND CONCLUSIONS ON MORTAR TESTING

5.1 Bedding Mortar

5.1.1 Consistency

The consistency tests performed in the current research helped determine the amount of water to add to the mortar mixture for optimum plasticity and to ensure uniformity in mortar batches. The range of appropriate consistency for this thesis was a flow between 0.2 in. (5.08 mm) and 2.0 in. (50.8 mm), with lime putty mortar toward the higher end of the range and Portland cement mortar toward the lesser value.

5.1.2 Water Retention

The lime putty mortar had the highest water content of the bedding mortars. This is largely due to the high moisture content of lime putty from storage under water. The natural hydraulic lime mortar contained more water than the Portland cement mortar, although the latter required more mix water than the former. This discrepancy may be due to the fact that the Portland cement mortar retained nearly 99% of its water, whereas the natural hydraulic lime mortar retained only 94% of its water—the lowest water retention value of the three binders. The lime putty mortar retained more water than the natural hydraulic lime—over 95% of its water—a contrast to what is expected of this material.¹ Table 5.1 shows the water content and retention values of the bedding mortar formulations.

Table 5.1. Bedding Mortar Water Content and Retention Values

Binder	Water content	Average water retention
Lime Putty	19%	95.67%
Natural Hydraulic Lime	12%	94.07%
Portland Cement	10%	98.99%

¹Thompson, "Plasticity, Water Retention, Soundness and Sand Carrying Capacity," 166.

5.1.3 Bleeding

All three bedding mortar formulations had a comparably high rate of bleeding, although the bleeding of each mortar peaked at different times. Graph 5.1 shows the bleeding rate of these mortars.

Graph 5.1. Comparison of the Bleeding Rate of Bedding Mortars

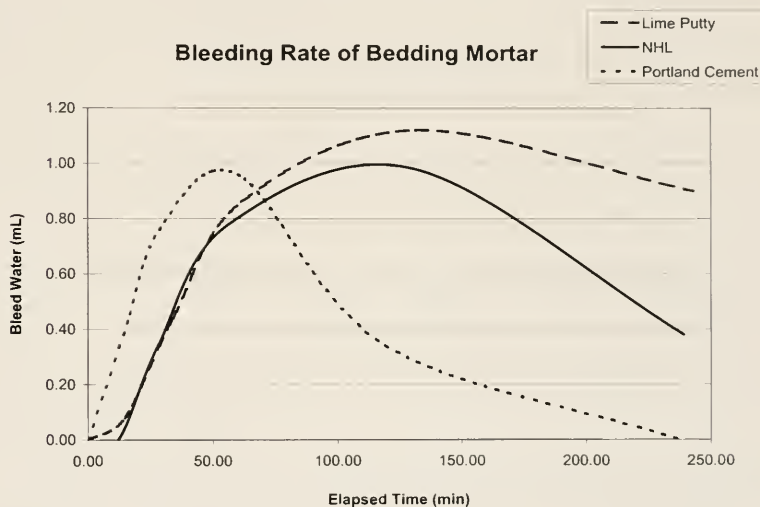

The bleeding rate of the natural hydraulic lime significantly slowed approximately 180 minutes after mixing, while the Portland cement mortar sharply dropped one hour after mixing. Portland cement mortars had the highest rate of bleeding of the bedding mortars, and had the highest volume of bleed water within one hour after mixing. Graph 5.2 shows that the lime putty and natural hydraulic lime mortars continued to bleed at a steady rate, while the Portland cement mortar leveled off one hour after mixing; it is likely that the bleed rate of Portland cement was affected by the rapid set time of this binder.

Graph 5.2. Cumulative Bleed Rate of Bedding Mortar

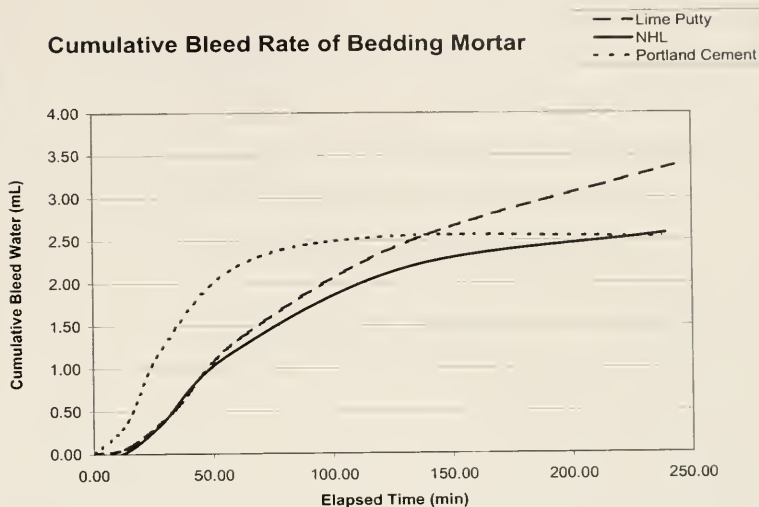

5.1.4 Set Time

The set time tests reported in this thesis show that bedding repair mortar made with Portland cement, natural hydraulic lime, and lime putty set consistently with published set time studies. Mortars based on lime putty typically set several days after molding, although the set time of lime putty mortars is increased when a pozzolanic component, such as brick dust, is added to the mortar. Portland cement mortars commonly set after only a few hours in the mold. Similar to Portland cement, hydraulic lime mortars contain hydraulic calcium silicate (Portland cement contains mainly calcium trisilicate with some dicalcium silicate, while hydraulic lime contains calcium disilicate). This hydraulic component in natural hydraulic lime allows mortars made with this binder to set a great deal more rapidly than lime putty mortars, yet not as rapidly as Portland cement mortars.

As anticipated the Portland cement bedding mortar formulation tested in this

thesis began to set approximately one hour after molding and finally set after almost five hours in the mold. The natural hydraulic lime bedding mortar began to set about six hours after molding and was fully set after ten hours in the mold. The lime putty bedding mortar with the brick dust additive began to set after almost thirty hours in the mold and was fully set almost forty-eight hours after molding. Graph 5.3 shows the set time tests of the different bedding mortar formulations.

Graph 5.3. Bedding Mortar Set Time Tests

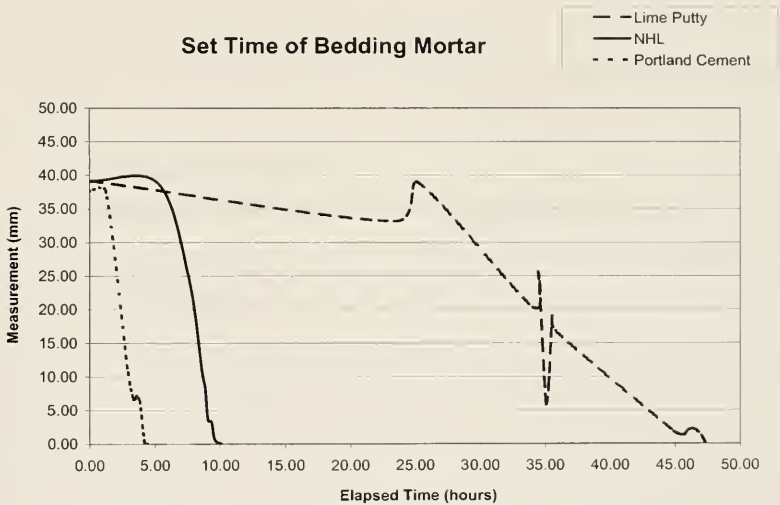

5.1.5 Conclusion

The hot, arid climate of Cairo requires that the mortar used to repair the Ayyubid wall exhibit high water retention. According to the water retention tests, the most appropriate bedding mortar to repair the Ayyubid wall would be a lime putty or Portland cement-based mortar as these binders have the highest water retention percentages.

The repair mortar for the Ayyubid wall should also have low to moderate bleeding to reduce the amount of binder that is leached from the wall during precipitation. Some

bleeding is appropriate, however, to ensure proper mortar adhesion to the stone. Lime-based mortars do not react chemically when water evaporates during set. Instead, these mortars gain bond strength and adhesion when the binder forms a physical bond with the substrate. Conversely, Portland cement, hydraulic lime, and mortars with pozzolanic additives react chemically during hardening to form bonds with the masonry units. Therefore, bleeding is unfavorable to mortars made with Portland cement, natural hydraulic lime, and lime putty with a pozzolanic component (brick dust), as these binders do not physically bond to the stone during bleeding. Tests on the three bedding mortar formulations show that the Portland cement mortar had an unacceptably high bleeding rate for this type of binder, whereas the lime-based mortars had comparable bleed rates that were acceptable for this application.

The mortars used for bedding repairs on the Ayyubid wall should set quickly but must not have greater compressive or flexural strength than the Egyptian limestone to which it is applied. Mechanical tests must be performed in future work to determine which bedding mortar formulation has the appropriate strength relative to set time for the Ayyubid wall repairs. Lime-based mortars typically have low compressive and flexural strength, but must remain porous enough to allow further carbonation. According to K. Van Balen and D. Van Gemert, the optimum condition for lime-based mortars “after which carbonation can start, is ... low relative humidity, strong wind velocity and high temperature.”¹ The mortar used for bedding repairs of the Ayyubid wall should dry enough that it sets before the finish pointing repairs are made to the wall. The lime putty mortar with a pozzolanic component (brick dust) tested in this thesis had a slow set time but may not have ample time to thoroughly carbonate if finish pointing repairs are made immediately after the bedding mortar is applied. Natural hydraulic lime mortar has a more moderate set time, but carbonation depth is also an issue with this binder. Portland

¹ K. Van Balen and G. Van Gemert, “Modelling Lime Mortar Carbonation,” *Materials and Structures* 27 (1994), 394.

cement mortar sets rapidly and does not carbonate, making this mortar a possible choice for bedding repair; however, this mortar commonly has great compressive and flexural strength and may not be appropriate for bedding repairs. Table 5.2 summarizes the acceptable mortar formulations for each application.

Table 5.2. Acceptable Binders for Completed Tests

Test	Bedding Mortar
Water Retention	Lime Putty or Portland Cement
Bleeding	Lime Putty or Natural Hydraulic Lime
Set Time	Lime Putty (with brick dust), Natural Hydraulic Lime, or Portland Cement

From the tests performed in this thesis, the lime putty or natural hydraulic lime mortars provide the optimum working properties for bedding repair of the Ayyubid wall. These tests are not conclusive, however, unless related to dry mortar and mechanical tests of these mortar formulations.

5.2 Finish Pointing Mortar

5.2.1 Consistency

The consistency tests performed in the current research helped determine the amount of water to add to the mortar mixture and ensured uniformity in mortar batches. The range of appropriate consistency for this thesis was a flow between 0.2 in. (5.08 mm) and 2.0 in. (50.8 mm), with lime putty mortar toward the higher end of the range and Portland cement mortar toward the lesser value.

5.2.2 Water Retention

The water retention of mortars used for finish pointing repair followed trends reported in published research. The lime putty finish pointing mortar had a high water

content—higher than the lime putty bedding mortar—and retained less water than the natural hydraulic lime mortar. The Portland cement formulation had a slightly lower water retention than that used for bedding mortar repair, but was still retained the highest percentage of mix water. Table 5.3 shows the water content and retention of the finish pointing mortar formulations.

Table 5.3. Finish Pointing Mortar Water Content and Retention

Binder	Water Content	Average Water Retention
Lime Putty	22%	94.72%
Natural Hydraulic Lime	13%	95.33%
Portland Cement	12%	97.41%

5.2.3 *Bleeding*

The finish pointing mortar formulations had a high variability in bleed rates. The mortar based on lime putty had significantly higher rates and quantities of bleeding compared to the natural hydraulic lime and Portland cement formulations. Graph 5.4 shows that the lime putty mortar peaked approximately one hundred minutes after mixing, and slowly decreased as time elapsed.

Graph 5.4. Bleeding Rates of Finish Pointing Mortars

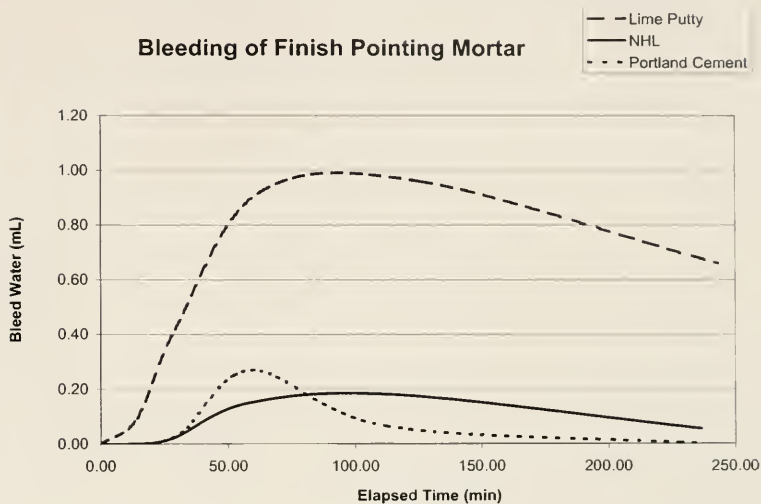

The natural hydraulic lime mortar bled the least, but also peaked one hundred minutes from mixing. The Portland cement mortar peaked one hour after mixing and rapidly decreased until the completion of the test. Graph 5.5 compares the cumulative bleed rates of the finish pointing mortars.

Graph 5.5. Cumulative Bleeding Rates of Finish Pointing Mortar

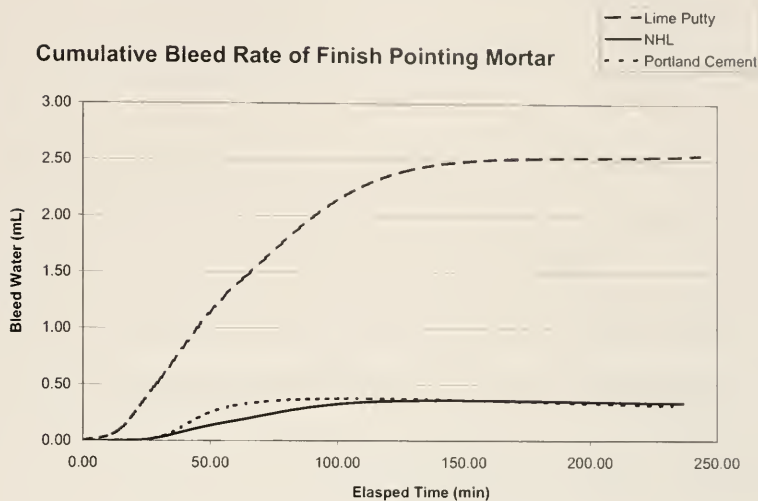

5.2.4 Set Time

The finish pointing mortar formulations set much later than the bedding mortars due to the water retention capabilities of the wood ash. The Portland cement mortar began to set three hours after molding and finally set after approximately five hours in the mold. The natural hydraulic lime mortar began to set after nearly ten hours in the mold and had some differential setting within the mold before it was fully set twelve hours after molding. The lime putty mortar with the pozzolanic component (brick dust) began to set approximately forty-eight hours after molding and finally set after nearly sixty-eight hours in the mold. Graph 5.6 shows the set time of the finish pointing mortar formulations.

Graph 5.6. Finish Pointing Mortar Set Times

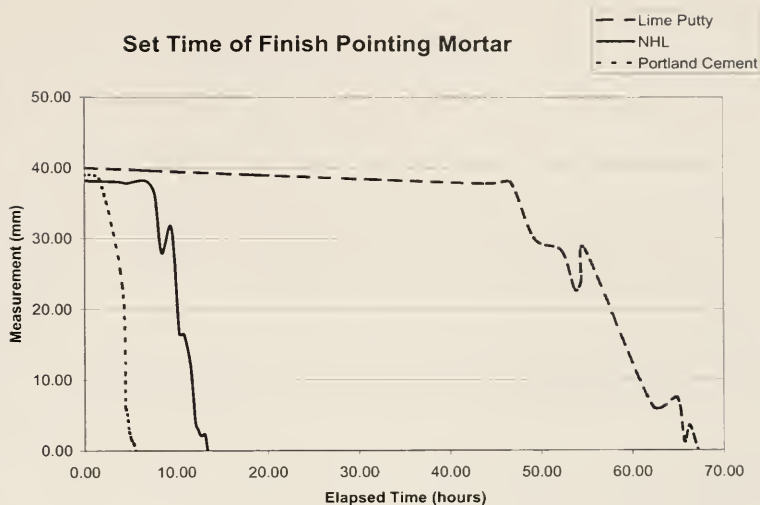

5.2.5 Conclusion

The hot, arid climate of Cairo requires that the mortar used to repair the Ayyubid wall exhibit high water retention. Wood ash added to the finish pointing mortar formulation contributes water retention properties to the mortar. This is particularly necessary for mortars applied to the surface of a wall in Cairo's desert environment. The water retention tests on the finish pointing mortar show that the natural hydraulic lime and Portland cement had the best water retention, although there was not a great amount of water retention difference between the natural hydraulic lime and the lime putty mortars. Therefore, any of these binders could be used for the finish pointing mortar repairs.

The repair mortar for the Ayyubid wall should also have low to moderate bleeding to reduce the amount of binder that is leached from the wall during setting. Some bleeding is appropriate, however, to ensure proper mortar adhesion to the stone.

Lime-based mortars do not react chemically when water evaporates during set. Instead, these mortars gain bond strength and adhesion when the binder forms a physical bond with the substrate. Conversely, Portland cement, hydraulic lime, and lime mortars with pozzolanic additives react chemically during hardening to form bonds with the masonry units. Therefore, bleeding is unfavorable to mortars made with Portland cement, natural hydraulic lime, and lime putty with a pozzolanic component (brick dust), as these binders do not physically bond to the stone during bleeding. The finish pointing mortars had vastly different bleeding rates due to the water retention properties of the wood ash additive. The Portland cement and natural hydraulic lime mortars had extremely low bleeding rates, while the lime putty formulation had a moderate bleeding rate. The latter binder had an acceptable bleeding rate for finish pointing repairs.

Finish pointing mortars should have a slow set time to accommodate proper carbonation in the arid climate of Cairo. Lime-based mortars set slowly, but must remain porous enough to allow further carbonation into the mortar. The lime putty mortar with a pozzolanic component (brick dust) had the slowest set time, although the natural hydraulic lime mortar also had a more moderately slow set time. Portland cement mortar set too rapidly for use as finish pointing mortar. Table 5.4 summarizes the acceptable mortar formulations for each application.

Table 5.4. Acceptable Binders for Completed Tests

Test	Finish Pointing Mortar
Water Retention	Lime Putty, Portland Cement, or Natural Hydraulic Lime
Bleeding	Lime Putty
Set Time	Lime Putty (with brick dust) or Natural Hydraulic Lime

From the tests performed in this thesis, the lime putty with brick dust or natural hydraulic lime mortars display the optimum properties for finish pointing repair of the

Ayyubid wall. These tests are not conclusive, however, unless related to dry mortar and mechanical tests of these mortar formulations.

5.3 Future Research

Tests must be performed on cured mortar formulations to determine the most appropriate mortar for bedding and finish pointing repair. These tests should include compressive and flexural strength, adhesion, elasticity, water absorption, water vapor permeability, bulk density, and salt resistance. Additionally, the alternative shrinkage test described in Section 3.7 should be performed to completely assess the characteristics associated with drying. Recommended standards include ASTM C 349-97 for compressive strength, ASTM C 78-94 for flexural strength, ASTM C952-91 for bond strength, ASTM C 469-94 for modulus of elasticity, NORMAL 7/81 and NORMAL 29/88 for water absorption and drying curves, and EN 1015-10a: 1995 E for bulk density. Water vapor permeability tests should be based on the American (ASTM E96-95) and European standards (NORMAL 21/85) with varying relative humidity storage chambers.

Further testing must be performed on the capillary water absorption of Egyptian limestone to clarify which binder has the most appropriate water retention and bleeding rate for repairing the Ayyubid wall.

CHAPTER 6—INFLUENCE OF SURFACTANTS ON SALT CRYSTALLIZATION

6.1 Introduction

The presence of salts is one of the most important deterioration factors for inorganic porous materials. Salts may be introduced into masonry from varying sources. In the case of the Egyptian limestone used to construct and repair the Ayyubid wall, salts were deposited during the formation of the stone by the precipitation of calcium carbonate, gypsum, and halite from seawater in ancient sea beds.¹ Furthermore, the stones used on the Ayyubid wall have been exposed to additional salts present in the soil of the city's nearby historic dumping grounds, known as the Darassa Hills.

Soluble salts are readily absorbed through the capillary suction of mortar and stone. Salt solutions at constant temperature and relative humidity will not deteriorate masonry. Fluctuations of these atmospheric conditions are required to cause damage to the stone. Decreased relative humidity will cause the solution to evaporate from the stone. If evaporation occurs on the surface of the stone, salts will crystallize on this outer zone to form efflorescence. Efflorescence does not harm the stone surface, although it often signals the presence of additional salts within the stone. If the evaporation front occurs beneath the surface of the stone—inside the capillaries and pores—the salts will crystallize to form subflorescences. This will inevitably result in the deterioration of the porous material.

6.2 Surfactants

A surfactant is a surface active agent that is adsorbed at the surface of a solid, liquid, or gas, or is adsorbed at the liquid/solid, liquid/liquid, or gas/liquid interfaces. Surface active agents are called surfactants in the United States and in much of the published literature, but they are called tensides or tensio-active agents in Europe, and

¹ Bouguignon, "Deterioration Mechanisms," 19.

may be referred to as associating colloids, colloidal electrolytes, paraffin chain salts, or amphipathic compounds.² Surfactants are used for a variety of purposes. They are commonly used as detergents, surface wetting agents, anti-swelling agents, desalination aids, dispersing aids, biocides, release agents, lubricants, anti-corrosive treatments, defoamers, and softening agents.³ While the majority of surfactants available on the market are detergents, not all have this function.⁴ Surfactants used for art and architectural conservation are commonly mixed in an aqueous solution and are applied to the surface of a solid.

Surfactants have two distinct regions: a hydrophilic head and a hydrophobic tail (Figure 6.1). The tail consists of long chains of hydrocarbons or fluorocarbons that are arranged linearly or in a branched fashion. Ninety-nine percent of surfactants have a

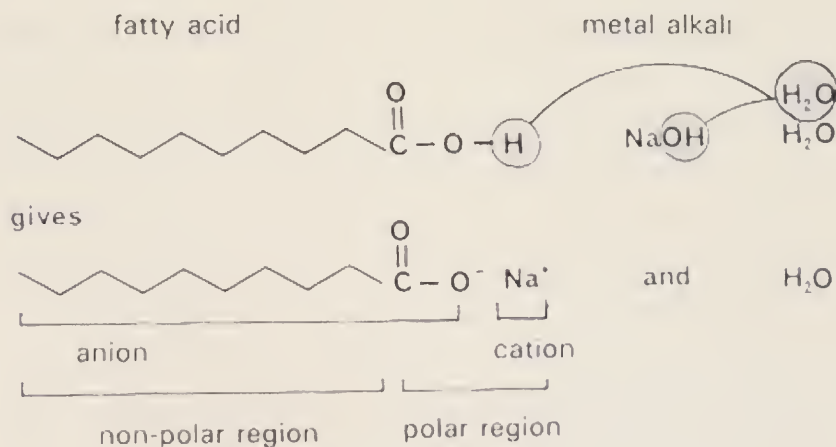

Figure 6.1. Surfactant molecules. (A. Southall, "Detergents Soaps Surfactants," 29.)

² R.H. Ottewill, "Introduction," *Surfactants*, ed. Th.F. Tadros (London, Academic Press, Inc., 1984), 2.

³ M.R. Porter, *Handbook of Surfactants*, 2nd ed. (London: Blackie Academic and Professional, 1994), 3-4; Carlos Rodriguez-Navarro, Eric Doehne and Eduardo Sebastian, "Influencing Crystalization Damage in Porous Materials Through the Use of Surfactants: Experimental Results Using Sodium Dodecyl Sulfate and Cetyltrimethylbenzylammonium Chloride," *Langmuir* 16 (2000), 947.

⁴ Conversely, all detergents are surfactants. Ottewill, "Introduction," 2.

hydrocarbon tail,⁵ and the majority of these are composed of twelve to eighteen carbon atoms.⁶ The hydrophilic part of the surfactant can be positively or negatively charged, nonionic, or amphoteric, meaning it has both positive and negative charges.

Surfactants work by decreasing the surface tension of an aqueous solution and solubilizing materials that are otherwise insoluble in water. The hydrophilic head is adsorbed by the solution and has a strong attraction to water molecules. Due to the strong repulsion of water molecules on the surface of a solution, the hydrophobic tails project from the surface of the solution and concentrate at this interface, while the hydrophilic head remains in the body of the solution. Therefore, surfactants have the highest concentration at the interfacial surface—between the liquid and the air, the liquid and insoluble liquid (such as oil and water), or between liquid and a solid.

At low concentrations, surfactant molecules lie flat on the interfacial surface or are randomly distributed in the solution. As the concentration of the surfactant increases, the hydrocarbon tails collect on the interfacial surface of the solution and form an organized monolayer (Figure 6.2). This is known as the critical micelle concentration (cmc) and marks the lowest concentration of surfactant necessary to obtain the largest decrease in surface tension of the solution. At cmc, the surface tension (or contact angle) at the liquid/solid interface is greatly reduced, and improves wetting of the substrate.

At concentrations above cmc the surfactant forms micelles, which are rod-shaped, spherical, or lamellar organized structures of surfactant molecules. Micelle shape is dependant on the type of surfactant used, its concentration, the temperature of the solution, and the presence of ions in the aqueous solution.⁷ During micellization, the hydrophilic head of the surfactant maintains its attraction to the water in aqueous solution and makes up the outer surface of the micelle. The interior of the micelle is made up of

⁵ Porter, *Handbook of Surfactants*, 11.

⁶ D.C. Cullum, ed. *Introduction to Surfactant Analysis* (London: Blackie Academic and Professional, 1994), 17.

⁷ Porter, *Handbook of Surfactants*, 35.

the hydrophobic tails, and has similar properties to liquid hydrocarbon. The hydrocarbon center of the micelle solubilizes materials that are otherwise insoluble in water, giving the surfactant its characteristic detergency. Therefore, the concentration of a surfactant must be above cmc for the surfactant to act as a detergent.⁸

Surfactants are classified by the charge of their hydrophilic head, and may be considered cationic, anionic, non-ionic, or amphoteric surfactants.

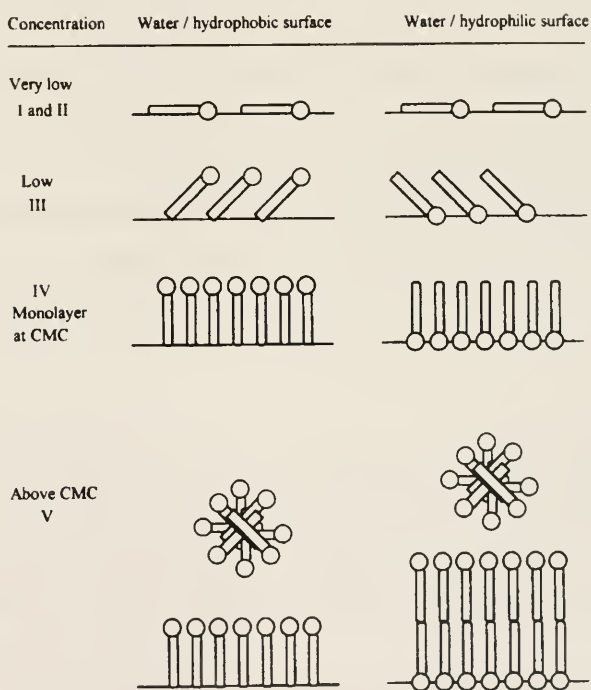

Figure 6.2. Surfactant Organization at Different Concentrations
(Porter, *Handbook of Surfactants*, 30)

⁸ Anna Southall, "Detergents Soaps Surfactants," *Dirt and Pictures Separated* (London: United Kingdom Institute for Conservation of Historic and Artistic Works, 1990), 31.

6.2.1 Cationic Surfactants

Cationic surfactants have a positively charged hydrophilic head. The positive charge is commonly carried by a nitrogen atom, although phosphorous or sulfur atoms may (rarely) provide the positive charge. Cationic surfactants are commonly used for fabric softeners, germicides and bactericides, anti-static coatings, and hair conditioners.⁹ Cationic surfactants make excellent bactericides because the long chain fatty amines present in the hydrocarbon tail, particularly those tails with twelve to sixteen hydrocarbons, have the ability to kill microorganisms.¹⁰ They are best suited for acidic solutions, rendering them poor detergents, and are attracted to negatively charged particles. Additionally, they are more expensive than anionic surfactants. Due to their low detergency and expense, they are less frequently used for conservation treatments.¹¹

Cationic surfactants based on amine and imidazoline salts, such as 1,4-diaminobutane dihydrochloride (BDAC), are strongly adsorbed by metals and fibers. Cationic surfactants composed of inorganic salts have low solubility in cold water and will form insoluble compounds if combined with anionic surfactants.¹²

6.2.2 Anionic Surfactants

Anionic surfactants are the most common type of surfactant on the market.¹³ Their negatively charged hydrophilic head may be derived from a carboxylate, sulphonate, sulphate, or phosphate group. These surfactants are inexpensive and have excellent detergency. Common used as soaps, shampoos, and detergents, they may also be used as emulsifiers and lubricants.¹⁴

Anionic surfactants with an alcohol sulfate group, such as Orvus WA paste, should

⁹ Southall, "Detergents Soaps Surfactants," 30.

¹⁰ Porter, *Handbook of Surfactants*, 256.

¹¹ Southall, "Detergents Soaps Surfactants," 30.

¹² Porter, *Handbook of Surfactants*, 256.

¹³ Porter, *Handbook of Surfactants*, 99.

¹⁴ Porter, *Handbook of Surfactants*, 99-168.

be used only in neutral pH environments.¹⁵ They are soluble in water, but the viscosity of the surfactant is increased with the addition of an electrolyte, particularly electrolytes containing chlorides or sulfides.¹⁶ They have excellent wetting properties, particularly those surfactants with smaller hydrocarbon chains, and are superior detergents.¹⁷

6.2.3 *Nonionic Surfactants*

The hydrophilic head of nonionic surfactants has no charge but is water soluble due to ethylene oxide chains and hydroxyl groups. Nonionic surfactants are excellent detergents due to their lower cmc and larger micelle size compared to ionic surfactants. Their cmc is lowered with increased temperature due to improved solubility of the surfactant molecule.¹⁸ Nonionic surfactants, however, provide average wetting properties, and the addition of electrolytes such as inorganic salts will decrease the wetting capabilities of the surfactant despite decreasing its cmc.¹⁹

Nonionic surfactants composed of alcohol ethoxylates, such as Triton XL-80N, are excellent detergents, emulsifiers, wetting agents, and dispersing agents.²⁰ They should be used in acidic or neutral environments and are unstable in alkaline solutions.²¹

6.2.4 *Amphoteric Surfactants*

Amphoteric surfactants have both positive and negative charges in their hydrophilic head. These surfactants are infrequently used in both conservation and as commercial detergents because they are expensive,²² but they may be used at any pH

¹⁵ Porter, *Handbook of Surfactants*, 116.

¹⁶ Porter, *Handbook of Surfactants*, 119.

¹⁷ Porter, *Handbook of Surfactants*, 120.

¹⁸ Porter, *Handbook of Surfactants*, 182.

¹⁹ Porter, *Handbook of Surfactants*, 182-183.

²⁰ Porter, *Handbook of Surfactants*, 192.

²¹ Porter, *Handbook of Surfactants*, 191.

²² Southall, "Detergents Soaps Surfactants," 30.

because they form cations in solutions of low pH and anions in alkaline solutions.²³ They are highly soluble molecules and may be used in combination with ionic or nonionic surfactants.

6.2.5 Wetting and Contact Angle

The wetting of a solid surface is directly related to the intersurface tension or contact angle of the liquid. The contact angle is the measured angle between the solid surface and the tangent line on the opposite side of a liquid droplet (Figure 6.3). Liquids with lower surface tension—a small contact angle—have better wetting properties than liquids with high surface tension—a large contact angle. Complete wetting occurs when the contact angle is zero, and complete non-wetting occurs in liquids with a 180° contact angle.²⁴

Wetting occurs when a surfactant has reached cmc. The monolayer of surfactants formed on the air/liquid interface when the surfactant has reached cmc will significantly reduce the surface tension of the liquid, thus improving the wetting capabilities of the

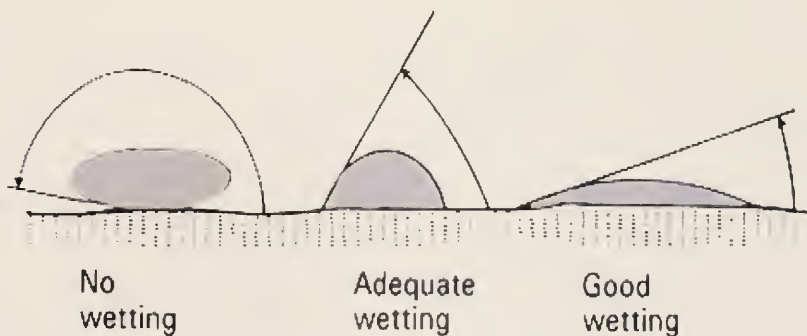

Figure 6.3. Contact Angle. From A. Southall, "Detergents Soaps Surfactants," 31.

²³ Porter, *Handbook of Surfactants*, 258.

²⁴ T.D. Blake, "Wetting," *Surfactants*, ed. Th.F. Tadros (London: Academic Press, Inc., 1984), 222.

liquid. By reducing the surface tension of the solution, surfactants can accelerate the capillary transport of the liquid; when used in a saline environment, surfactants can promote efflorescence while decreasing the tendency of salts to crystallize below the surface of the masonry material.²⁵ Surfactants typically enhance wetting on non-polar, low-energy surfaces that are poorly wet by water.²⁶ Reduced surface tension causes the surface of the liquid to expand, spreading the liquid along the solid surface. When the liquid expands, its surfactant concentration is more diffuse and more surfactants must be adsorbed for the liquid to spread further.²⁷ The addition of an electrolyte to the solution will also improve wetting by lowering the surface tension of the solution.²⁸ Conversely,

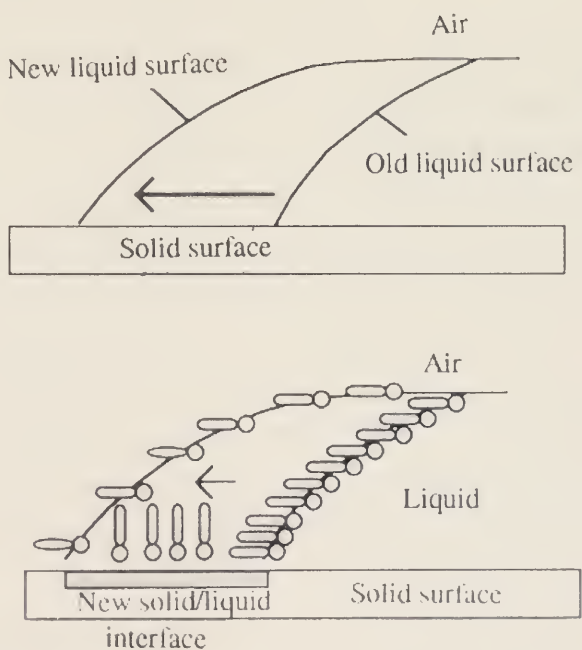

Figure 6.4. Diffusion of Surfactant During Wetting. (Porter, *Handbook of Surfactants*, 62)

²⁵ Rodriguez-Navarro et al., "Influencing Crystallization Damage," 948.

²⁶ Blake, "Wetting," 243.

²⁷ Porter, *Handbook of Surfactants*, 62.

²⁸ Porter, *Handbook of Surfactants*, 64.

surfactant solutions impair the wetting of polar surfaces because there is little surfactant adsorption by a solid when the surfactant and solid are similarly charged.²⁹

The porosity of the solid may also affect the wetting efficacy of surfactant solutions. Surfactants in solution may concentrate on the capillary walls of a porous solid (the liquid/solid interface), causing a decreased concentration of surfactants on the air/liquid interface; this will raise the surface tension of the solution.³⁰ Therefore, more surfactants must be adsorbed by the solution to achieve cmc when used with a porous material.

6.3 Effect of Surfactants on Salt Crystallization

It is widely known that surfactants influence the crystallization of soluble materials. According to J. Pühringer, the size and shape of salt crystals is determined by changes in the vapor pressure above salt solutions influencing their crystallization during evaporation.³¹ Surfactants also have the ability to change the charge of the solid, liquid, or vapor which it contacts; this charge change can influence the formation of particles. For example, Pühringer stated that “[c]ationic surfactants can alter the state of charge on the surfaces of salt particles and on the whole retard particle formation.”³²

Y. Ueno found that surfactants with low vapor pressures, such as nonionic surfactants, increase the coagulation of aerosols.³³ This research can be used to predict that clusters of salt crystals will precipitate from nonionic surfactant solutions. Pühringer suggested that some nonionic surfactants prevent or decrease evaporation of the

²⁹ Blake, “Wetting,” 243, 252.

³⁰ Blake, “Wetting,” 266.

³¹ Josef Pühringer, “Building Moisture Physics—Salts and Surfactants,” *Nordic Symposium on Building Physics* (Lund, Sweden: Lunds Universitet, 1987), 472.

³² Pühringer, “Building Moisture Physics,” 474.

³³ Yasuo Ueno, “Studies of Salt-Solution Aerosols—XIII: Effect of Surface-Active Substances on the Stability of Aqueous Salt Solution Aerosols,” *Atmospheric Environment* 10 (1976), 412.

solution due to the low vapor pressure of the surfactant.³⁴ Some surfactants also act as a nucleation inhibitor, delaying the crystallization of salts from solution. C. Rodriguez-Navarro et al. found that nucleation inhibitors were most effective in desalination and for the prevention of salt damage because they promoted salt crystallization on the surface of the masonry, rather than subsurface salt formation.³⁵

6.4 Poulticing

In 2002, J. Moon researched the desalination effects of nonionic and anionic surfactants on Egyptian limestone. She obtained newly quarried Egyptian limestone samples and impregnated them with a saturated sodium chloride (NaCl) solution. Moon brushed some samples with Triton™ XL-80 N, a nonionic surfactant produced by Union Carbide Corp., others with Orvus WA paste, an anionic surfactant produced by Proctor & Gamble, or isolated the samples as controls. She then twice poulticed all samples with a paper pulp poultice saturated with tap water, a solution of Triton, or a solution of Orvus.

The poulticing results produced by J. Moon show, in general, that both surfactants increased the desalination of Egyptian limestone.³⁶ Table 6.1 summarizes Moon's desalination results.

³⁴ Pühringer cites W.W. Mansfield, "Influence of Monolayers on the Natural Rate of Evaporation of Water," *Nature* 175 (1955), 247-249. Mansfield's research focuses on cetyl alcohol monolayers, and does not mention nonionic surfactants. Pühringer, "Building Moisture Physics," 473.

³⁵ Carlos Rodriguez-Navarro, Lucía Linares Fernandez and Eduardo Sebastian, "New Developments for Preventing Salt Damage to Porous Ornamental Materials Through the Use of Crystallization Inhibitors," *SALTeXPERT Workshop: Salt Damage and Desalination*. Prague: ARCCHIP and the Getty Conservation Institute, 2002 (to be posted <http://www.arcchip.cz/#workshops>).

³⁶ Moon, "Desalination Methodologies," 71.

Table 6.1. Desalination Results by J. Moon

Treatment type	Total NaCl in stone (%w/w)	Total NaCl poulticed (%w/w)	% NaCl removed
Salt-impregnated samples poulticed with water	4.19	2.39	56.97
Salt-impregnated samples not brushed, poulticed with Orvus	4.04	2.76	68.25
Salt-impregnated samples not brushed, poulticed with Triton	3.83	2.80	73.07
Salt-impregnated samples brushed with Orvus, poulticed with water	3.89	1.83	47.13
Salt-impregnated samples brushed with Triton, poulticed with water	4.00	2.67	66.93
Salt-impregnated samples brushed with Orvus, poulticed with Orvus	3.97	2.25	56.63
Salt-impregnated samples brushed with Triton, poulticed with Triton	4.12	2.15	52.14
Salt-impregnated samples brushed with Orvus, poulticed with Triton	4.02	2.35	58.41
Salt-impregnated samples brushed with Triton, poulticed with Orvus	4.12	2.16	52.40

Samples brushed with one surfactant and cross poulticed (e.g., brushed with Triton, poulticed with Orvus) and samples brushed with one surfactant and poulticed with the same surfactant (e.g., brushed with Triton, poulticed with Triton) produced similar desalination results as the unbrushed stones poulticed with tap water. Moon determined that brushing the stones with nonionic Triton and poulticing with tap water increased the salt extraction by over 66%, while brushing with anionic Orvus and poulticing with tap

water reduced the amount of salt in the stone by over 47%, a lower extraction than that obtained by tap water poulticing which had a 57% reduction in salt content.³⁷ Graph 6.1 shows the salt extraction of surfactants compared with water poulticing.

Graph 6.1. Moon's Salt Extraction Results—Brushing with Orvus or Triton; Poulticing with Tap Water

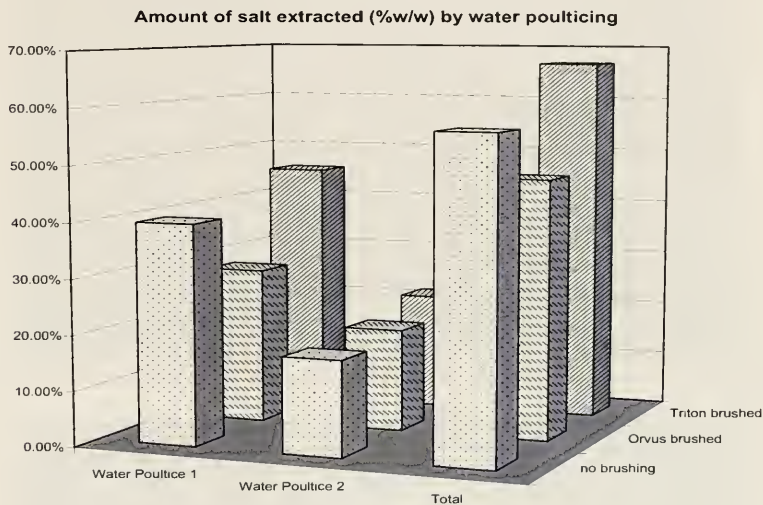

The results obtained by J. Moon led to the current research that aims to explain the effect of different surfactants on the crystallization of salts. Scanning electron micrographs of the poulticed samples revealed that surfactants influence the size and shape of sodium chloride crystals. Samples examined by SEM were removed approximately 1.5 cm (0.59 in.) from the edge of the Egyptian limestone cubes, and were examined with a JEOL JSM-6300 FV scanning microscope in January 2003. The control sample (saturated with salt but not treated with surfactants) showed cubic crystals, the largest of which was approximately 1 μm in length (Figure 6.5). A salt-impregnated sample poulticed twice with tap water resulted in cubic crystals with slightly rounded

³⁷ Moon, "Desalination Methodologies," 71.

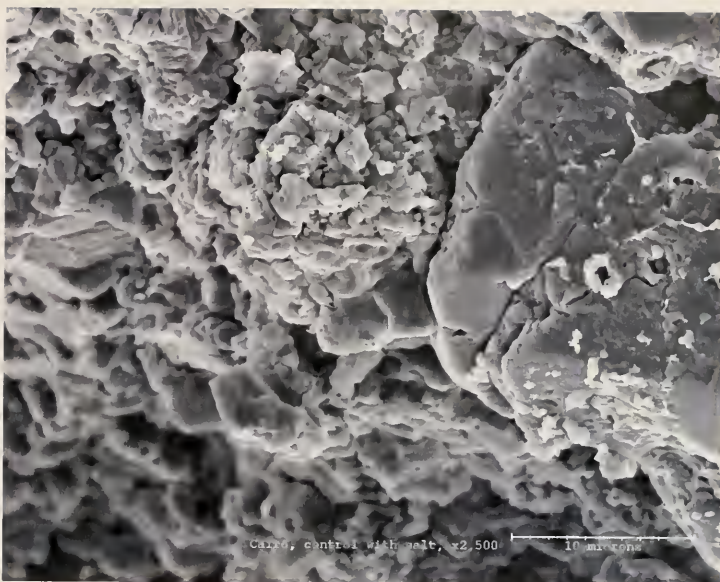

Figure 6.5. Egyptian Limestone Control Sample Impregnated with Sodium Chloride. 2,500x magnification

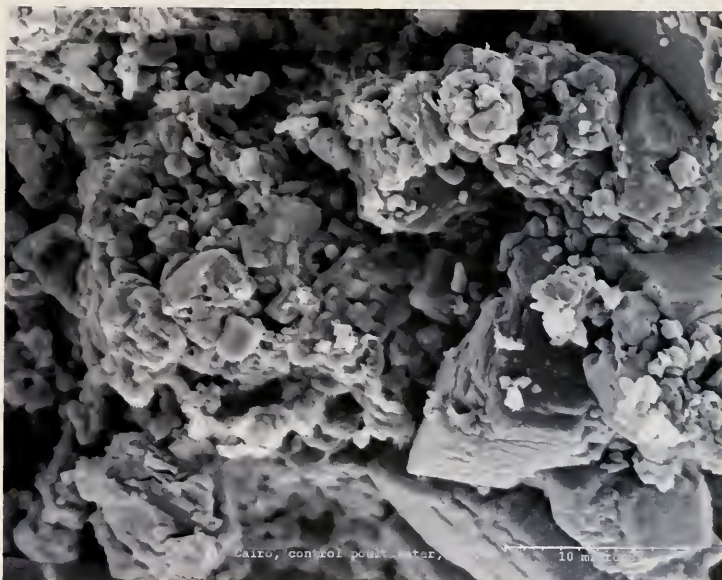

Figure 6.6. Egyptian Limestone Impregnated with Sodium Chloride, Poulitced with Tap Water. 2,500x magnification

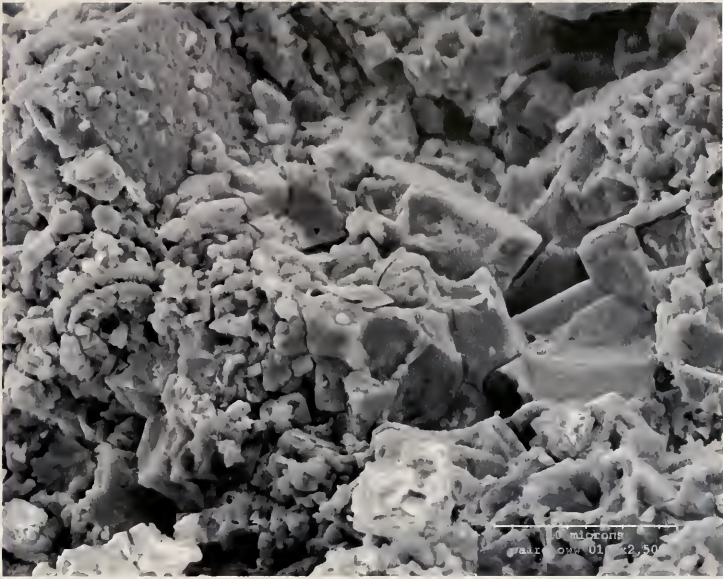

Figure 6.7. Egyptian Limestone Sample Impregnated with Sodium Chloride, Brushed with Orvus, Poulticed with Tap Water. 2,500x magnification

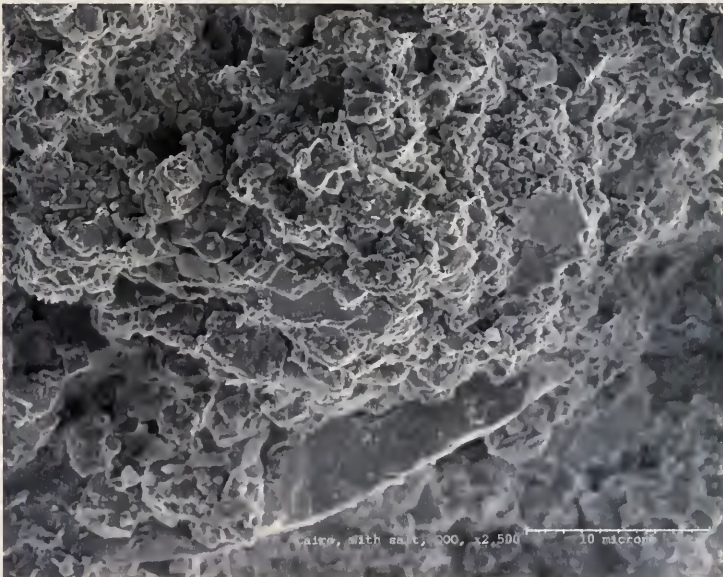

Figure 6.8. Egyptian Limestone Sample Impregnated with Sodium Chloride, Brushed with Orvus, Poulticed with Orvus. 2,500x magnification

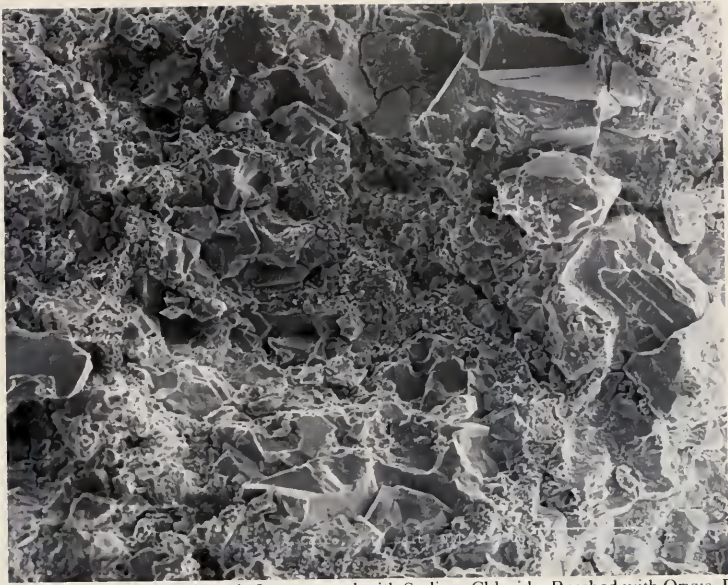

Figure 6.9. Egyptian Limestone Sample Impregnated with Sodium Chloride, Brushed with Orvus, Poulticed with Triton. 1,500x magnification

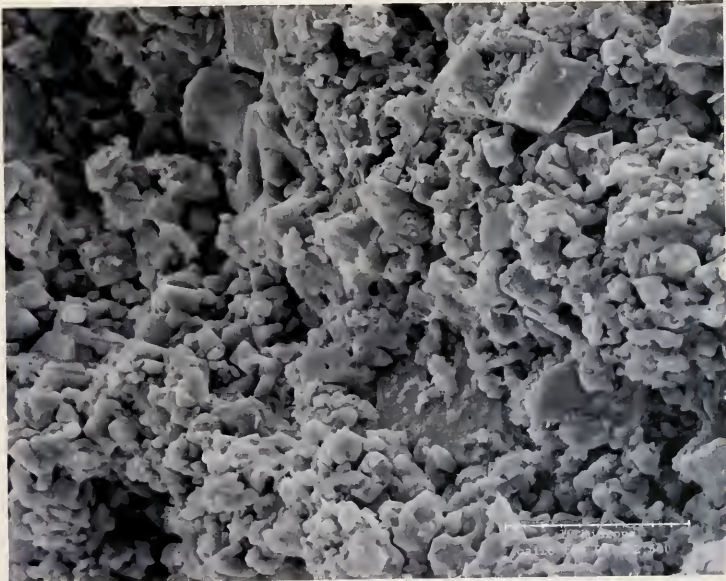

Figure 6.10. Egyptian Limestone Sample Impregnated with Sodium Chloride, Brushed with Triton, Poulticed with Tap Water. 2,500x magnification

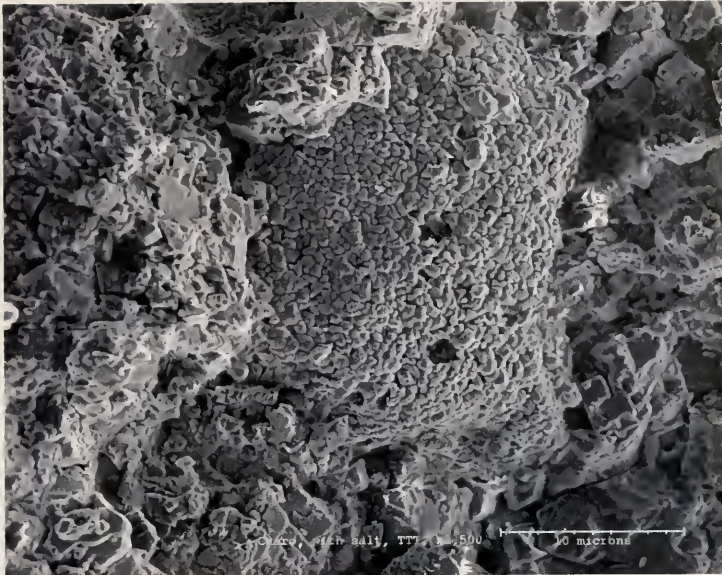

Figure 6.11. Egyptian Limestone Sample Impregnated with Sodium Chloride, Brushed with Triton, Poulitced with Triton. 2,500x magnification

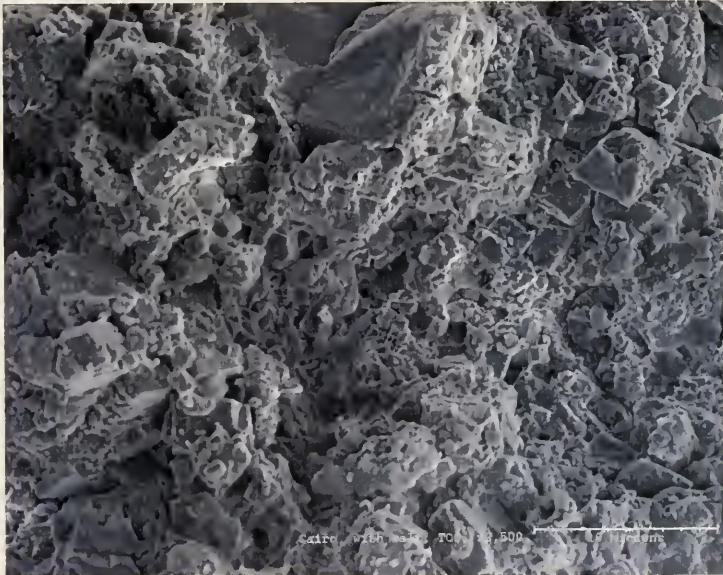

Figure 6.12. Egyptian Limestone Sample Impregnated with Sodium Chloride, Brushed with Triton, Poulitced with Orvus. 2,500x magnification

edges that were approximately 1 μm in length evenly dispersed throughout the limestone substrate (Figure 6.6).

Samples brushed with anionic Orvus WA paste and poulticed with tap water showed larger masses of salt crystals surrounding calcite crystals and fossils; these salts varied in size from 2 μm to 0.5 μm in length and were generally cubic in shape (Figure 6.7). Samples brushed and poulticed with Orvus formed rounded-edged rectangular and cubic salt crystals between 2 μm to 0.5 μm in length; these salt crystals were evenly distributed throughout the limestone sample (Figure 6.8). Cross-treated stones brushed with Orvus and poulticed with Triton resulted in bands of small crystals, the majority of which are less than 0.5 μm in length; these crystals are clustered together and surround larger pieces of calcite (Figure 6.9).

Samples brushed with nonionic Triton XL-80N and poulticed with tap water showed rounded rectangular crystals that densely surround calcite crystals of the stone; these salts are less than 1 μm in length (Figure 6.10). Samples brushed and poulticed with Triton resulted in clusters of densely packed salt crystals smaller than 1 μm in length (Figure 6.11). Stones brushed with Triton and poulticed with Orvus showed cubic salt crystals well dispersed through the stone substrate that were approximately 1 μm in length (Figure 6.12).

The size and distribution of the recrystallized salts can be attributed to unique characteristics of the Orvus and Triton surfactants. The viscosity of anionic surfactants with an alcohol sulfate group, such as Orvus WA paste, increases with the addition of an electrolyte, particularly electrolytes containing chloride or sulfide ions.³⁸ Viscous solutions have low migration rates and will result in less salt dispersion than non-viscous solutions. Furthermore, Pühringer found that anionic surfactants “migrate along the phase boundary between water and particle surfaces” and will increase the evaporation

³⁸ Porter, *Handbook of Surfactants*, 119.

rate of the solution.³⁹ This causes salts treated with anionic surfactants to form large, disperse crystals, and will cause the salt solution to creep.

During evaporation, sodium chloride solutions undergo a phenomenon called creep, in which the crystallization of salts draws the solution beyond its original boundaries. Surfactants aid the creeping of salts by reducing the surface tension of the salt solution. Laboratory observations of varying solutions of Triton and Orvus surfactants in saturated sodium chloride confirm this assertion. Experiments performed on saturated sodium chloride solutions in beakers with varying concentration of surfactants showed that increased Orvus—the anionic surfactant—concentration (from 0.5% to 2% w/v) accelerated sodium chloride creep on the side of the beaker (Figure 6.13). Increased concentration of Triton (from 0.5% to 2% w/v) caused a marked decrease in creep (insert photo); a 2% w/v concentration of Triton completely suppressed salt creep (Figure 6.14).

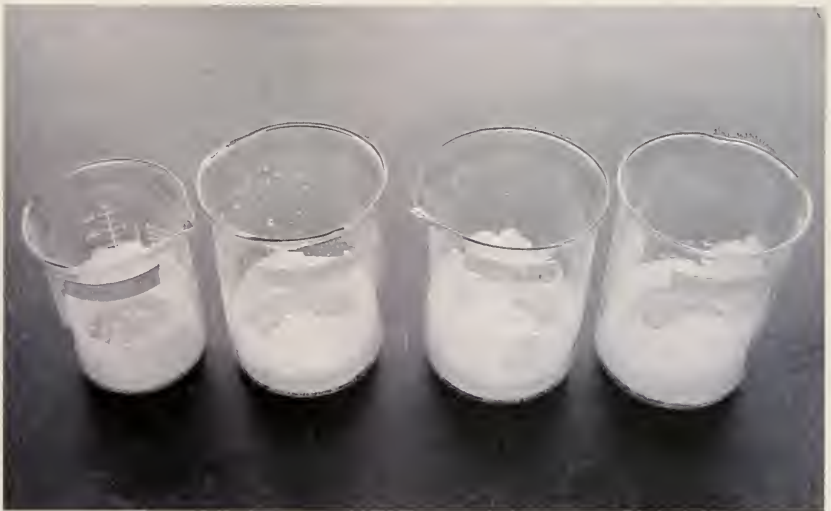

Figure 6.13. Beakers of Saturated Sodium Chloride Solution and Varying Concentrations of Orvus (evaporated). From left to right: Control; 0.5% w/v Orvus; 1% w/v Orvus; 2% w/v Orvus.

³⁹ Pühringer, "Building Moisture Physics," 473. (Pühringer cites R. Söderblom, "The Effect of Effluent on Clay (in Swedish)," *Swedish Council for Building Research Project No. 780895-3*.)



Figure 6.14. Beakers of Saturated Sodium Chloride Solution and Varying Concentrations of Triton (evaporated). From left to right: Control; 0.5% w/v Triton; 1% w/v Triton; 2% w/v Triton.

Additionally, a drop of 2% w/v Triton solution on a glass slide failed to fully evaporate in laboratory conditions (approximately 22°C [71.6°F] and 34% RH). This confirms Pühringer's claim that nonionic surfactants decrease evaporation of the solution due to the low vapor pressure associated with nonionic surfactants.⁴⁰

6.5 Conclusions

Surfactants have been proven effective in the extraction of sodium chloride from Egyptian limestone. However, the influence of the surfactants on salt crystallization must be considered when determining whether these chemicals should be used to desalinate the Ayyubid wall. Not only do surfactants affect the crystallization of salts, but they will undoubtedly modify the growth of calcite crystals during the carbonation of lime-based mortars as well as the shape and size of crystals growing during the pozzolanic

⁴⁰ Pühringer, "Building Moisture Physics," 473.



Figure 6.15. Salt Crystals Growing from a 2% w/v Triton Solution. 40x magnification. Note wet edges of the salt crystals.

reaction between the brick dust and binder. It is likely that surfactants will negatively change the growth of calcite crystals in the hydraulic reaction, which could affect the properties of the mortar. It has already been noted that nonionic surfactants are unstable in alkaline solutions.⁴¹ Therefore, nonionic surfactants, such as Triton XL-80N, should not be used to desalinate the Ayyubid wall as they may negatively react with the alkaline repair mortar formulations. The Egyptian limestone in the Ayyubid wall contains small amounts of gypsum, which would also be affected by surfactant treatment. Finally, any changes in the crystal habit of the gypsum and calcite due to the presence of surfactants could significantly affect the bond strength of the mortar to the stone.

Additional studies on the effects of Triton and Orvus surfactants with calcite, brick dust, wood ash, and gypsum are required before desalinating the Ayyubid wall with surfactants. It is not advisable to apply surfactants to a structure which is undergoing repointing or other treatments, or to a structure that has unmitigated moisture problems.

⁴¹ Porter, *Handbook of Surfactants*, 191.

Surfactants may be used, however, to desalinate valuable surface finishes, such as plasters in stairwells or chambers within the Ayyubid wall, to protect surface finishes that may be deteriorating from the presence of soluble salts in the wall. Nevertheless, salt extraction on surface finishes in these chambers should only be performed after extensive on-site testing with surfactants.

The current research will help determine the effects of surfactants on the crystallization of mortar components, such as calcite formation, when a surfactant-treated wall is repointed. Furthermore, research into surfactants will help conservators determine the effect of surfactants on the adhesion of repair mortar and Egyptian limestone.

APPENDIX A—MATERIAL CHARACTERISTICS

Bani Yousef Sand for Bedding Mortar

Particle Size Distribution

ASTM Sieve Number	Screen Size (µm)	Mass of container (g)	Mass of sample & container (g)	Mass retained (g)	Percent mass retained	Percent on or above	Percent passing
8	2360	6.55	12.73	6.18	4.46	4.46	95.54
16	1180	6.85	23.85	17.00	12.25	16.71	83.29
30	600	6.67	55.64	48.97	35.30	52.01	47.99
50	300	6.57	57.78	51.21	36.92	88.93	11.07
100	150	6.65	17.94	11.29	8.14	97.07	2.93
200	75	6.70	9.42	2.72	1.96	99.03	0.97
Pan	0	6.80	7.96	1.16	0.84	99.86	0.14

Particle Size Distribution--Bani Yousef Sand for Bedding Mortar

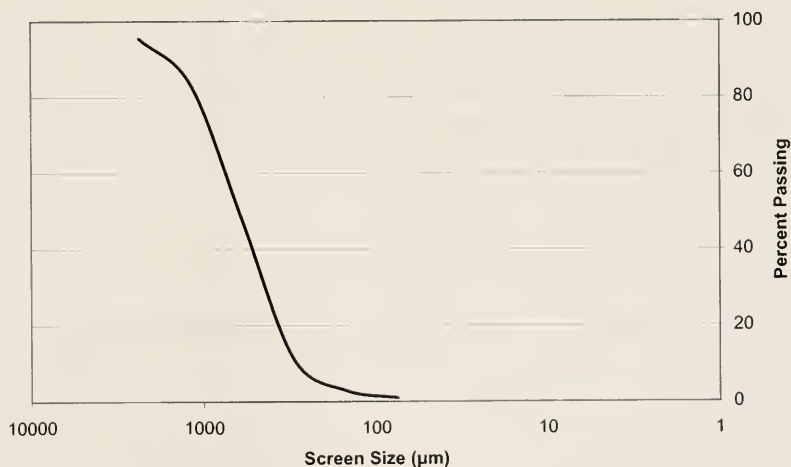

APPENDIX A

Bani Yousef Sand for Bedding Mortar

X-Ray Diffraction Analysis
Laboratory for Research on the Structure of Matter
University of Pennsylvania
March 2003

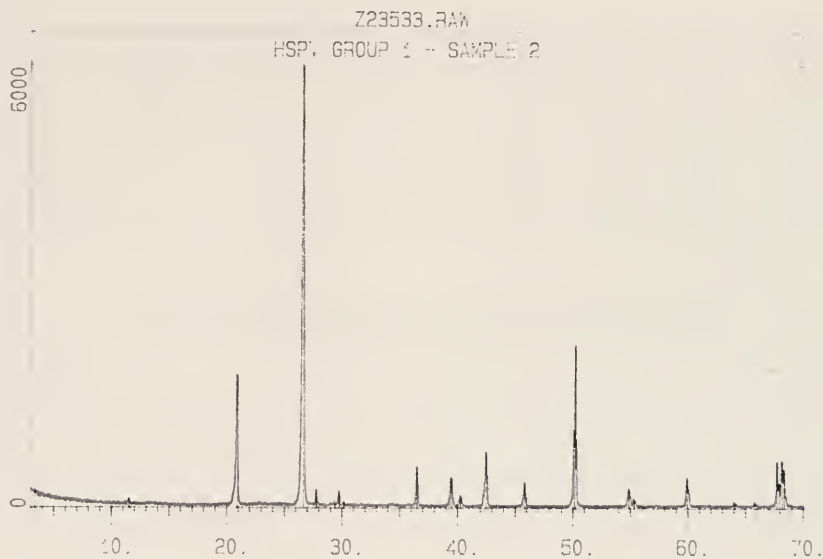

APPENDIX A

Kempf Concrete Sand

Particle Size Distribution

ASTM Sieve Number	Screen Size (µm)	Mass of container (g)	Mass of sample & container (g)	Mass retained (g)	Percent mass retained	Percent on or above	Percent passing
8	2360	7.16	13.28	6.12	5.38	5.38	94.62
16	1180	6.84	30.60	23.76	20.88	26.26	73.74
30	600	7.14	48.41	41.27	36.27	62.52	37.48
50	300	7.31	41.13	33.82	29.72	92.24	7.76
100	150	7.16	15.19	8.03	7.06	99.30	0.70
200	75	7.09	7.67	0.58	0.51	99.81	0.19
Pan	0	7.19	7.28	0.09	0.08	99.89	0.11

Particle Size Distribution--Kempf Concrete Sand

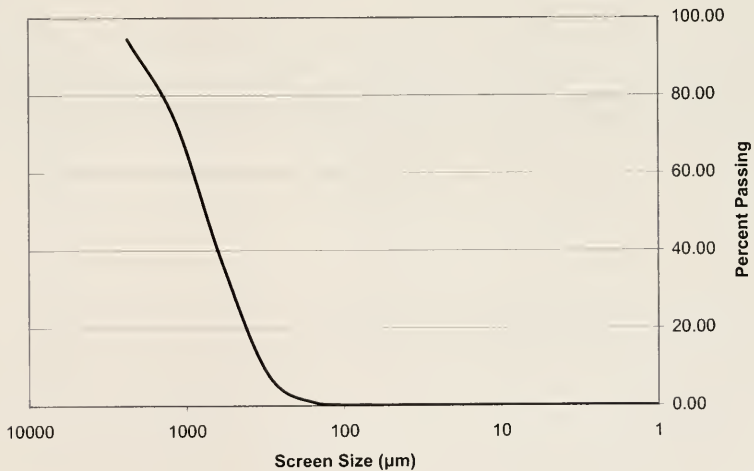

APPENDIX A

Kempf Concrete Sand

X-Ray Diffraction Analysis
Laboratory for Research on the Structure of Matter
University of Pennsylvania
March 2003

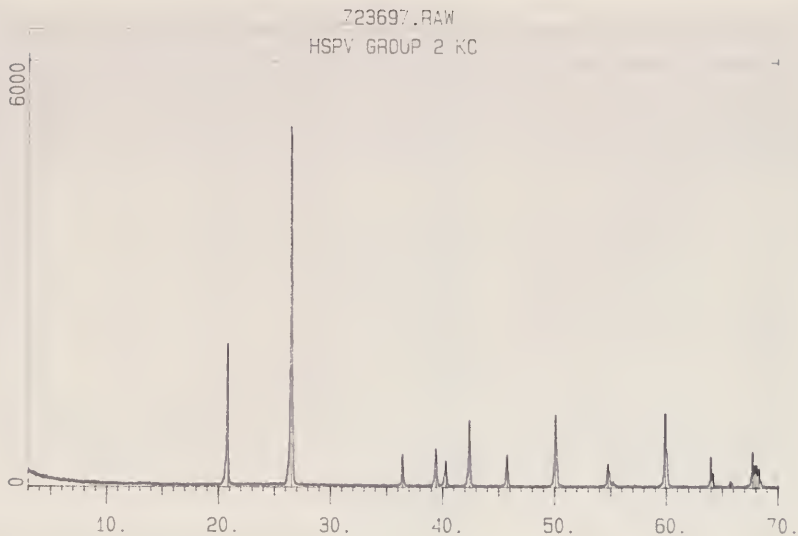

APPENDIX A

Brick Dust

X-Ray Diffraction Analysis
G&W Science and Engineering Company
Cairo, Egypt
December 18, 2002

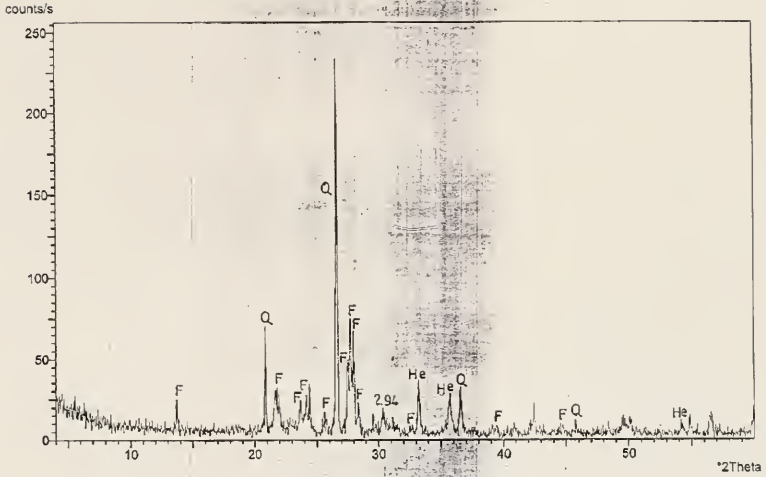

Figure 2: The X-ray diffraction patterns of the brick powder (sieved) . Bricks from demolition AKCS-E (lab code 360/02) .

APPENDIX A

High-Calcium Lime Putty

X-Ray Diffraction Analysis
G&W Science and Engineering Company
Cairo, Egypt
December 18, 2002

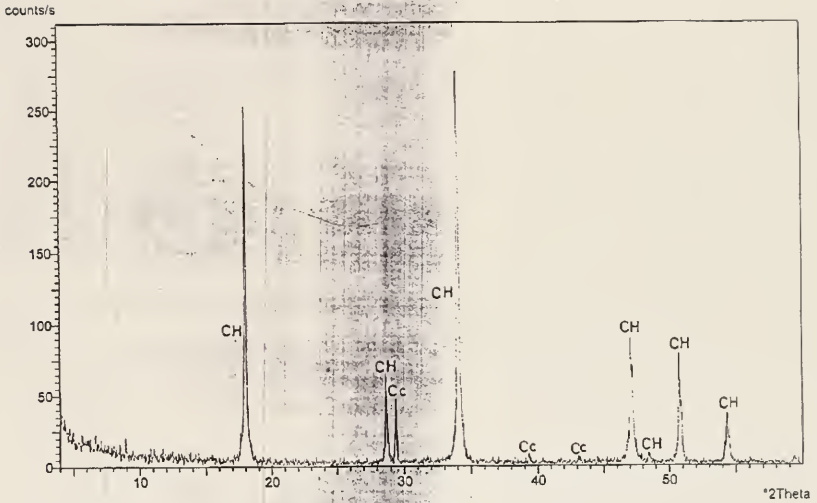

Figure 1: The X-ray diffraction patterns of the lime putty, 3-4 months in water
AKCS-E (lab code 351/02)

APPENDIX A

Bani Yousef Sand for Finish Pointing Mortar

Particle Size Distribution

ASTM Sieve Number	Screen Size (µm)	Mass of container (g)	Mass of sample & container (g)	Mass retained (g)	Percent mass retained	Percent on or above	Percent passing
8	2360	6.55	6.55	0.00	0.00	0.00	100.00
16	1180	6.85	6.88	0.00	0.00	0.00	100.00
30	600	6.69	50.88	44.19	39.30	39.30	60.70
50	300	6.80	57.98	51.18	45.51	84.81	15.19
100	150	6.58	18.50	11.92	10.60	95.41	4.59
200	75	6.64	10.08	3.44	3.06	98.47	1.53
Pan	0	6.68	8.28	1.60	1.42	99.89	0.11

Particle Size Distribution--Bani Yousef Sand for Finish Pointing Mortar

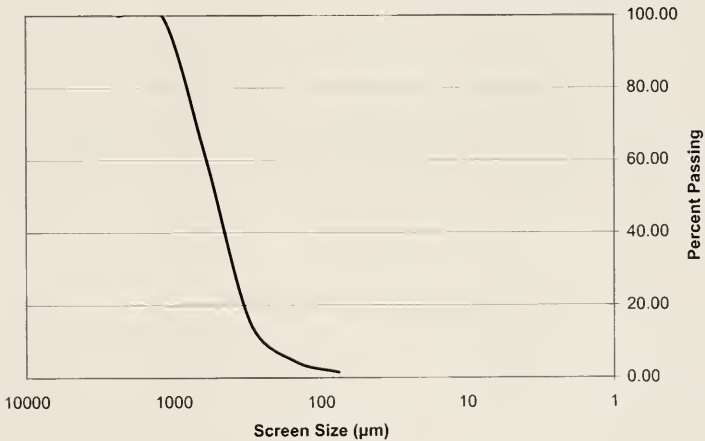

APPENDIX A

Bani Yousef Sand for Finish Pointing Mortar

X-Ray Diffraction Analysis
Laboratory for Research on the Structure of Matter
University of Pennsylvania
March 2003

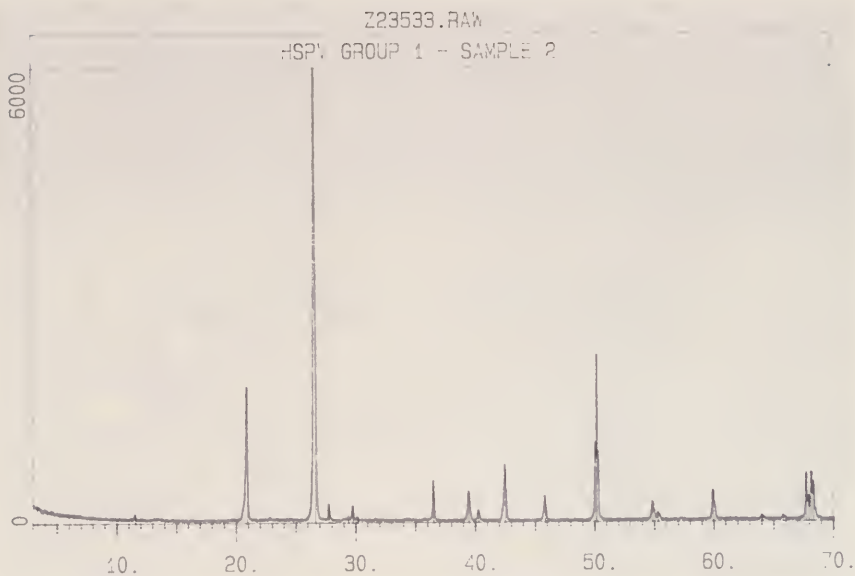

APPENDIX A

Kempf Yellow Bar Sand

Particle Size Distribution

ASTM Sieve Number	Screen Size (μm)	Mass of container (g)	Mass of sample & container (g)	Mass retained (g)	Percent mass retained	Percent on or above	Percent passing
8	2360	7.16	7.16	0.00	0.00	0.00	100.00
16	1180	6.83	6.83	0.00	0.00	0.00	100.00
30	600	7.14	32.05	24.91	21.12	21.12	78.88
50	300	7.29	80.41	73.12	61.98	83.10	16.90
100	150	7.15	24.20	17.05	14.45	97.55	2.45
200	75	7.08	9.35	2.27	1.92	99.47	0.53
Pan	0	7.18	7.80	0.62	0.53	100.00	0.00

Particle Size Distribution--Kempf Yellow Bar Sand

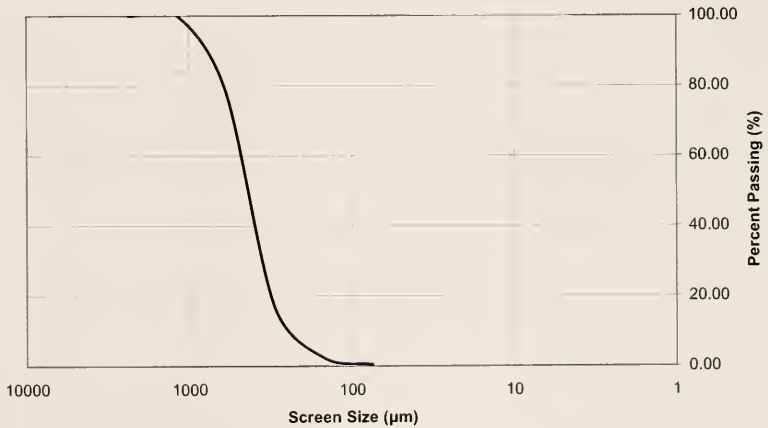

APPENDIX A

Kempf Yellow Bar Sand

X-Ray Diffraction Analysis
Laboratory for Research on the Structure of Matter
University of Pennsylvania
March 2003

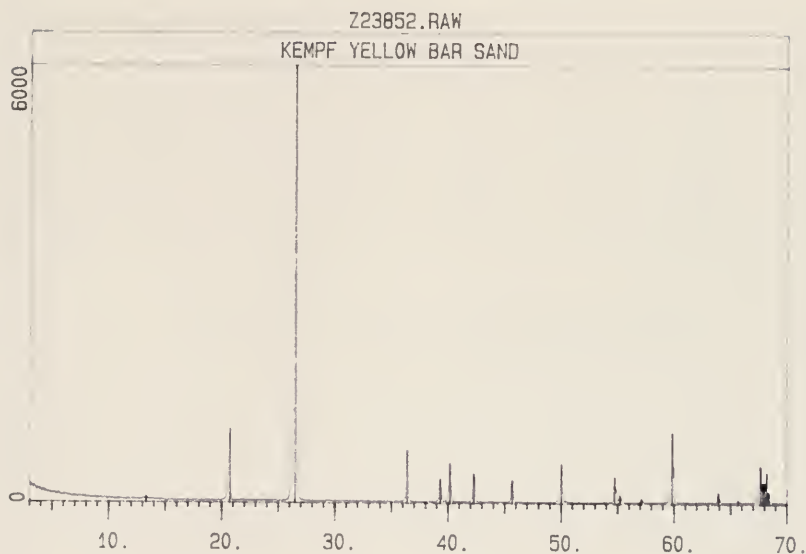

APPENDIX A

El Katameia Sand for Finish Pointing Mortar

Particle Size Distribution

ASTM Sieve Number	Screen Size (μm)	Mass of container (g)	Mass of sample & container (g)	Mass retained (g)	Percent mass retained	Percent on or above	Percent passing
8	2360	1.97	1.97	0.00	0.00	0.00	100.00
16	1180	1.97	1.97	0.00	0.00	0.00	100.00
30	600	2.00	11.03	9.03	8.24	8.24	91.76
50	300	1.99	89.45	87.46	79.85	88.09	11.91
100	150	6.56	17.68	11.12	10.15	98.25	1.75
200	75	6.64	8.03	1.39	1.27	99.52	0.48
Pan	0	6.67	7.03	0.36	0.33	99.84	0.16

Particle Size Distribution--El Katameia Sand

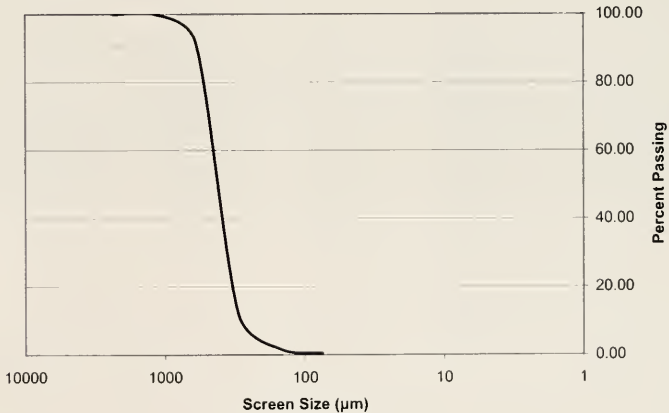

APPENDIX A

El Katameia Sand for Finish Pointing Mortar

X-Ray Diffraction Analysis
Laboratory for Research on the Structure of Matter
University of Pennsylvania
March 2003

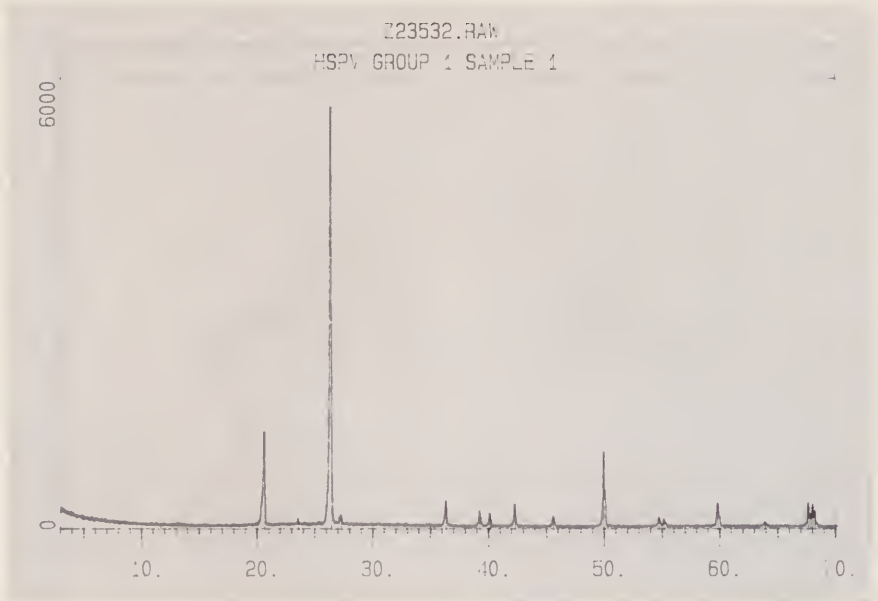

APPENDIX A

Schofield Yellow Mason Sand

Particle Size Distribution

ASTM Sieve Number	Screen Size (μm)	Mass of container (g)	Mass of sample & container (g)	Mass retained (g)	Percent mass retained	Percent on or above	Percent passing
8	2360	7.16	7.16	0.00	0.00	0.00	100.00
16	1180	7.12	7.12	0.00	0.00	0.00	100.00
30	600	7.03	27.13	20.10	11.36	11.36	88.64
50	300	7.07	119.91	112.84	63.77	75.12	24.88
100	150	7.22	42.71	35.49	20.06	95.18	4.82
200	75	7.03	10.85	3.82	2.16	97.34	2.66
Pan	0	7.05	7.59	0.54	0.31	97.64	2.36

Particle Size Distribution--Schofield Mason Sand

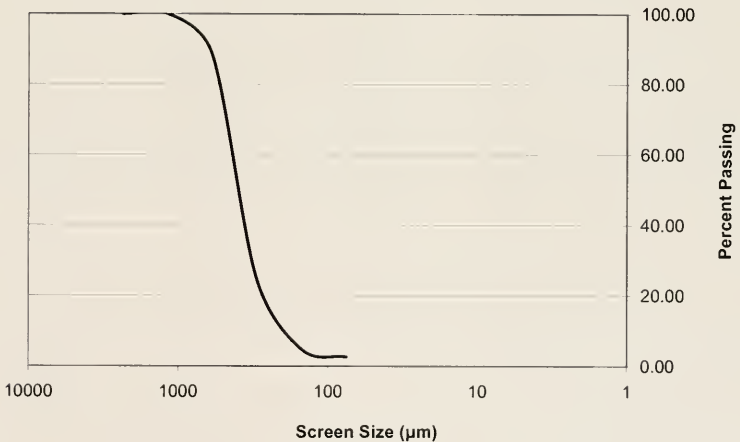

APPENDIX A

Schofield Yellow Mason Sand

X-Ray Diffraction Analysis
Laboratory for Research on the Structure of Matter
University of Pennsylvania
March 2003

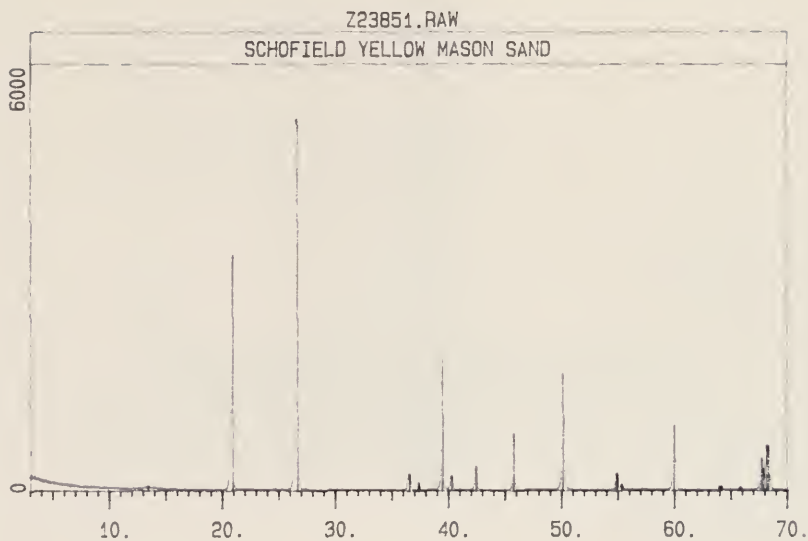

APPENDIX A

Wood Ash

X-Ray Diffraction Analysis
G&W Science and Engineering Company
Cairo, Egypt
December 18, 2002

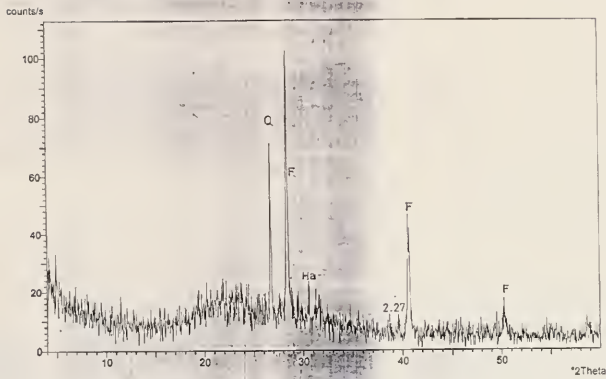
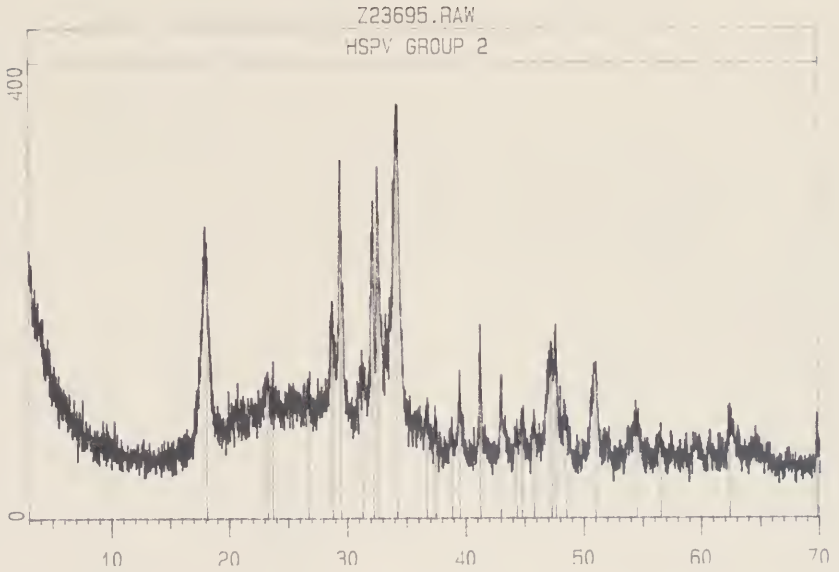

Figure 3: The X-ray diffraction patterns of the wood ash. Provenance: Qven from farmers at Abu Nomros AKCS-E (lab code 359/02)

APPENDIX A

Riverton Natural Hydraulic Lime

X-Ray Diffraction Analysis
Laboratory for Research on the Structure of Matter
University of Pennsylvania
March 2003



APPENDIX A

Riverton Natural Hydraulic Lime

X-Ray Diffraction Analysis

Peak search on 17-MAR-0314:20:06

d	I	d	I	d	I	d	I	d	I
4.914	67	3.036	87	2.4527	27	2.1063	28	1.9112	41
3.837	33	2.8632	34	2.4046	24	2.0447	21	1.8785	25
3.764	32	2.7816	77	2.3221	24	2.0265	26	1.7927	36
3.344	33	2.7483	79	2.2848	31	1.9828	23	1.6860	26
3.108	52	2.6248	100	2.1901	35	1.9249	42	1.6304	20

27 lines in pattern.

Identified Phases:

JCPDS#	SI	ML/X	At%	Identity . . .
83-0460C	129*	18/1	96	Calcium Silicate / Larnite = Ca ₂ (SiO ₄) derr:2.0 Bground:20 dmax/min:29.41/1.343
4-0733I	115	7/0	114	*Calcium Hydroxide / Portlandite, syn = Ca(OH) ₂ derr:2.0 Bground:20 dmax/min:29.41/1.343
5-0586*	58	4/1	117	*Calcium Carbonate / Calcite, syn = CaCO ₃ derr:2.0 Bground:20 dmax/min:29.41/1.343

Summary Report:

d	Full I	Resid I	83-0460:96% d	96% I	4-0733:114% d	4-0733:114% I	5-0586:117% d	5-0586:117% I
4.914	67	None			4.90	84		
3.837	33	13	3.8325	5.8*			3.86	14
3.764	32	32						
3.344	33	33						
3.108	52	26			3.112	26		
3.036	87	None					3.035	117
2.8632	34	17	2.8789	17				
2.7816	77	None	2.7883	75				
" "	"	"	2.7803	96				
2.7483	79	None	2.7448	77				
" "	"	"	2.7350	58				
			<2.7210	32>				
2.6248	100	None	2.6197	55	2.628	114		
2.4527	27	8	2.4430	16	2.447	3		
2.4046	24	None	2.4072	15				
2.3221	24	24						
2.2848	31	None	2.2921	5.8			[2.285	21]
" "	"	"	2.2854	19				
2.1901	35	None	2.1994	13				
" "	"	"	2.1907	37				
2.1063	28	28					<2.095	21>
2.0447	21	None	2.0521	11				
" "	"	"	2.0468	8.6				
2.0265	26	None	2.0285	9.6				
" "	"	"	2.0228	13				
1.9828	23	None	1.9802	18				
1.9249	42	None			1.927	48	[1.927	6]
1.9112	41	None	1.9162	11*			1.913	20
" "	"	"	1.9046	5.8*				
1.8785	25	None					1.875	20
1.7927	36	None	1.7940	8.6*	1.796	41		
1.6860	26	None			1.687	24		
1.6304	20	None	1.6287	12	[1.634	1]	[1.626	5]
1.4895	22	22						
1.3481	25	25						

* = Obscured <..> = Missing [..] = Previously Removed

APPENDIX A

Type I Gray Portland Cement

X-Ray Diffraction Analysis
Laboratory for Research on the Structure of Matter
University of Pennsylvania
March 2003

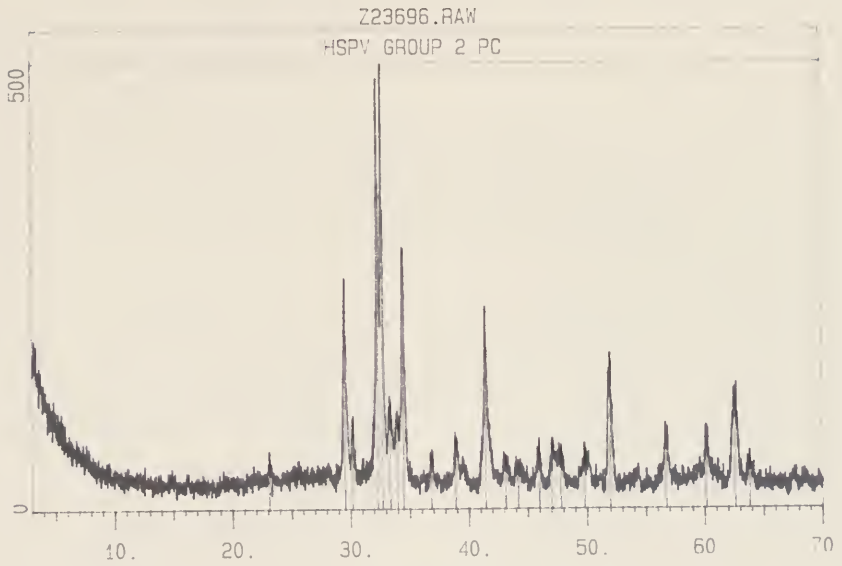

APPENDIX A

Type I Gray Portland Cement

X-Ray Diffraction Analysis

Input Pattern

HSPV GROUP 2 PC
Peak search on 17-MAR-0314:58:03

d	I	d	I	d	I	d	I	d	I		
3.857	13	2.7403	100	2.4437	13	2.0518	8.4	1.8331	15	1.4848	25
3.029	52	2.6875	24	2.3187	16	1.9755	16	1.7605	35	1.4597	13
2.9651	20	2.6414	19	2.1810	45	1.9318	16	1.6235	14		
2.7721	97	2.6040	59	2.0998	12	1.9044	14	1.5391	15		

22 lines in pattern.

Identified Phases:

JCPDS#	SI	ML/X	At%	Identity . . .
42-0551*	265*	29/2	79	Calcium Silicate = Ca3SiO5 derr:2.0 Bground:8.4 dmax/min:29.41/1.343
72-1651C	29	3/2	51	Calcium Carbonate / CALCITE = CaCO3 derr:2.0 Bground:8.4 dmax/min:29.41/1.343
30-11740	35	3/1	24	Sodium Calcium Silicate = Na4Ca8Si5O20 derr:2.0 Bground:8.4 dmax/min:29.41/1.343

Summary Report:

d	Full I	Resid I	42-0551: 79% d	79% I	72-1651: 51% d	51% I	30-1174: 24% d	24% I
3.857	13	None	<5.93	9.5>	3.8515	5.1		
3.029	52	None	3.87	2.4	[3.0279	51]		
2.9651	20	None	3.861	3.2				
"	"	"	3.036	32				
"	"	"	3.025	59				
"	"	"	2.968	9.5				
"	"	"	2.962	20			<2.86	11>
2.7721	97	30	2.773	67				
2.7403	100	None	2.748	36			[2.75	16]
"	"	"	2.738	59				
2.6875	24	None	2.690	4.7*			2.69	24
2.6414	19	None					2.65	16
2.6040	59	None	2.604	79			[2.61	7.2]
2.4437	13	None	2.444	7.1				
2.3187	16	None	2.323	7.1			[2.32	3.8]
"	"	"	2.316	16				
2.1810	45	None	2.181	47	<2.2832	9.7>		
"	"	"	<2.165	12>				
2.0998	12	None			2.0943	7.6		
2.0518	8.4	8.4						
1.9755	16	None	1.980	4.0			[1.98	6.0]
"	"	"	1.974	7.9				
1.9318	16	None	1.935	5.5	[1.9258	3.1]		
"	"	"	1.930	10				
1.9044	14	None			1.9045	9.2		
"	"	"			<1.8714	9.7>		
1.8331	15	None	1.832	5.5			1.83	6.0
1.7605	35	None	1.764	44				
"	"	"	1.758	24				
1.6235	14	None	1.626	4.0	[1.6262	1.5]		
"	"	"	1.623	12				
1.5391	15	None	1.539	16				
1.4848	25	None	1.489	7.9				
"	"	"	1.487	7.9				
"	"	"	1.485	7.9				
1.4597	13	None	1.462	3.2				
"	"	"	1.457	7.9				

* = Obscured <...> = Missing [...] = Previously Removed

APPENDIX B—BEDDING MORTAR TESTS

Consistency—Lime Putty Mortar

1 Lime Putty: 0.5 Brick Dust: 2.5 Sand Trial #1

March 9, 2003 Temperature: 68.2°F Relative Humidity 33%

Material	Quantity	Instrument	Proportion (by volume)
Kempf Concrete Sand (sieved #4 ASTM)	1250 mL	3 x 500 mL beakers	2.5
Brick dust	250 mL	500 mL beaker	0.5
Lime Putty	500 mL	500 mL beaker	1
Lime water	140 mL	3 x 50 mL graduated cylinders	0.3

Test	Measurement 1 (in)	Measurement 2 (in)	Original Dimensions (in)	Difference between Original and Measurement 1 (in)	Difference between Original and Measurement 2 (in)
1	5.177	5.314	2.730	2.447	2.584
2	5.336	5.486	2.730	2.606	2.756
3	5.689	5.641	2.730	2.959	2.911

Average Difference for Measurement 1 (in)	Average Difference for Measurement 2 (in)
2.671	2.750

Lime putty was wet
All materials at room temperature
First layer in mold tamped 10 times, second layer tamped 20 times
Mortar not mixed between tests 1, 2, and 3
Mortar stuck to inverted trowel after mixing

APPENDIX B

Consistency—Lime Putty Mortar

1 Lime Putty: 0.5 Brick Dust: 2.5 Sand Trial #2

March 10, 2003 Temperature: 68.9°F Relative Humidity 32%

Material	Quantity	Instrument	Proportion (by volume)
Kempf Concrete Sand (sieved #4 ASTM)	500 mL	500 mL beaker	2.5
Brick dust	100 mL	200 mL beaker	0.5
Lime Putty	200 mL	300 mL beaker	1
Lime water	50 mL	50 mL graduated cylinder	0.25

Test	Measurement 1 (in)	Measurement 2 (in)	Original Dimensions (in)	Difference Between Original and Measurement 1 (in)	Difference Between Original and Measurement 2 (in)
1	3.862	3.922	2.730	1.132	1.192
2	3.966	3.901	2.730	1.236	1.171
3	4.035	4.247	2.730	1.305	1.517

Average Difference for Measurement 1 (in)	Average Difference for Measurement 2 (in)
1.224	1.293

Lime putty was wet
All materials at room temperature
First layer in mold tamped 10 times, second layer tamped 20 times
Mortar remixed for 15 seconds between tests 1, 2, and 3
Mortar stuck to inverted trowel after mixing

APPENDIX B

Consistency—Lime Putty Mortar

1 Lime Putty: 0.5 Brick Dust: 2.5 Sand Trial #3

March 10, 2003 Temperature: 69.0°F Relative Humidity 33%

Material	Quantity	Instrument	Proportion (by volume)
Kempf Concrete Sand (sieved #4 ASTM)	500 mL	500 mL beaker	2.5
Brick dust	100 mL	200 mL beaker	0.5
Lime Putty	200 mL	300 mL beaker	1
Lime water	75 mL	100 mL graduated cylinder	0.375

Test	Measurement 1 (in)	Measurement 2 (in)	Original Dimensions (in)	Difference Between Original and Measurement 1 (in)	Difference Between Original and Measurement 2 (in)	Notes
1	beyond 6 inches	n/a	2.730	n/a	n/a	mixture too wet to measure

Average Difference for Measurement 1 (in)	Average Difference for Measurement 2 (in)
0.000	0.000

Lime putty very wet
All materials at room temperature
First layer in mold tamped 10 times, second layer tamped 20 times
Mortar did not stick to trowel (too wet) after mixing

APPENDIX B

Consistency—Lime Putty Mortar

1 Lime Putty: 0.5 Brick Dust: 2.5 Sand Trial #4

March 10, 2003 Temperature: 69.1°F Relative Humidity 32%

Material	Quantity	Instrument	Proportion (by volume)
Kempf Concrete Sand (sieved #4 ASTM)	500 mL	500 mL beaker	2.5
Brick dust	100 mL	200 mL beaker	0.5
Lime Putty	200 mL	300 mL beaker	1
Lime water	40 mL	50 mL graduated cylinder	0.2
	+ additional 25 mL (total of 65 mL lime water)	50 mL graduated cylinder	0.325

Test	Measurement 1 (in)	Measurement 2 (in)	Original Dimensions (in)	Difference Between Original and Measurement 1 (in)	Difference Between Original and Measurement 2 (in)	Notes
1	n/a*	n/a*	2.730	n/a*	n/a*	shearing, completely fell apart after 10 drops
2	4.510	4.629	2.730	1.780	1.899	
3	4.736	4.764	2.730	2.006	2.034	
4	4.582	4.517	2.73	1.852	1.787	

Average Difference for Measurement 1 (in)	Average Difference for Measurement 2 (in)
1.879	1.907

Lime putty really dry
All materials at room temperature
First layer in mold tamped 10 times, second layer tamped 20 times
Mortar remixed for 15 seconds between tests 2, 3, and 4
*First mortar formulation (test 1) was with 40 mL lime water (stuck briefly to inverted trowel-very dry mixture)
Second formulation (tests 2-4) was with 65 mL lime water (stuck briefly to inverted trowel-moist mixture)

APPENDIX B

Consistency—Natural Hydraulic Lime Mortar

1 Natural Hydraulic Lime: 0.5 Brick Dust: 2.5 Sand Trial #1

March 10, 2003 Temperature: 68.8°F Relative Humidity 32%

Material	Quantity	Instrument	Proportion (by volume)
Kempf Concrete Sand (sieved #4 ASTM)	500 mL	500 mL beaker	2.5
Brick dust	100 mL	200 mL beaker	0.5
Natural Hydraulic Lime	200 mL	300 mL beaker	1
Deionized Water	150 mL	100 mL & 50 mL graduated cylinders	0.75

Test	Measurement 1 (in)	Measurement 2 (in)	Original Dimensions (in)	Difference Between Original and Measurement 1 (in)	Difference Between Original and Measurement 2 (in)
1	5.004	5.038	2.730	2.274	2.308
2	4.983	4.985	2.730	2.253	2.255
3	5.065	4.999	2.730	2.335	2.269

Average Difference for Measurement 1 (in)	Average Difference for Measurement 2 (in)
2.287	2.277

All materials at room temperature except NHL--stored outside (approx. 40°F)

First layer in mold tamped 10 times, second layer tamped 20 times

Mortar remixed between tests 1, 2, and 3

Mortar briefly stuck to inverted trowel after mixing before sliding off

APPENDIX B

Consistency—Natural Hydraulic Lime Mortar

1 Natural Hydraulic Lime: 0.5 Brick Dust: 2.5 Sand Trial #2

March 10, 2003 Temperature: 68.3°F Relative Humidity 32%

Material	Quantity	Instrument	Proportion (by volume)
Kempf Concrete Sand (sieved #4 ASTM)	500 mL	500 mL beaker	2.5
Brick dust	100 mL	200 mL beaker	0.5
Natural Hydraulic Lime	200 mL	300 mL beaker	1
Deionized Water	130 mL	100 mL & 50 mL graduated cylinders	0.65

Test	Measurement 1 (in)	Measurement 2 (in)	Original Dimensions (in)	Difference Between Original and Measurement 1 (in)	Difference Between Original and Measurement 2 (in)
1	3.525	3.513	2.730	0.795	0.783
2	3.118	3.211	2.730	0.388	0.481
3	3.182	3.176	2.730	0.452	0.446

Average Difference for Measurement 1 (in)	Average Difference for Measurement 2 (in)
0.545	0.570

All materials at room temperature except NHL--stored outside (approx. 40 °F)
First layer in mold tamped 10 times, second layer tamped 20 times
Mortar remixed between tests 1, 2, and 3
Mortar did not stick to trowel

APPENDIX B

Consistency—Natural Hydraulic Lime Mortar

1 Natural Hydraulic Lime: 0.5 Brick Dust: 2.5 Sand Trial #3

March 10, 2003 Temperature: 68.2°F Relative Humidity 32%

Material	Quantity	Instrument	Proportion (by volume)
Kempf Concrete Sand (sieved #4 ASTM)	500 mL	500 mL beaker	2.5
Brick dust	100 mL	200 mL beaker	0.5
Natural Hydraulic Lime	200 mL	300 mL beaker	1
Deionized Water	140 mL	100 mL & 50 mL graduated cylinders	0.7

Test	Measurement 1 (in)	Measurement 2 (in)	Original Dimensions (in)	Difference Between Original and Measurement 1 (in)	Difference Between Original and Measurement 2 (in)
1	3.849	3.854	2.730	1.119	1.124
2	3.835	3.814	2.730	1.105	1.084
3	3.698	3.564	2.730	0.968	0.834

Average Difference for Measurement 1 (in)	Average Difference for Measurement 2 (in)
1.064	1.014

All materials at room temperature except NHL--stored outside (approx. 40 °F)
First layer in mold tamped 10 times, second layer tamped 20 times
Mortar remixed between tests 1, 2, and 3
Mortar did not stick to trowel

APPENDIX B

Consistency—Portland Cement Mortar

1 Portland Cement: 0.5 Brick Dust: 2.5 Sand Trial #1

March 10, 2003 Temperature: 69.2°F Relative Humidity 32%

Material	Quantity	Instrument	Proportion (by volume)
Kempf Concrete Sand (sieved #4 ASTM)	500 mL	500 mL beaker	2.5
Brick dust	100 mL	200 mL beaker	0.5
Portland Cement	200 mL	300 mL beaker	1
Deionized Water	130 mL	3 x 50 mL graduated cylinders	0.65
	+ additional 20 mL (total of 150 mL water)	50 mL graduated cylinder	0.75

Test	Measurement 1 (in)	Measurement 2 (in)	Original Dimensions (in)	Difference Between Original and Measurement 1 (in)	Difference Between Original and Measurement 2 (in)	Notes
1	n/a*	n/a*	2.730	n/a*	n/a*	sheared after 4 drops
2	3.665	3.856	2.730	0.935	1.126	
3	3.562	3.630	2.730	0.832	0.900	
4	2.961	3.090	2.730	0.231	0.360	

Average Difference for Measurement 1 (in)	Average Difference for Measurement 2 (in)
0.666	0.795

All materials at room temperature except Portland cement--stored outside (approx. 40 °F)
First layer in mold tamped 10 times, second layer tamped 20 times
Mortar remixed between tests 2, 3, and 4
*Test 1 (130 mL mix water): Mortar did not stick to inverted trowel after mixing
Tests 2-4 (150 mL mix water total): Mortar stuck to inverted trowel after mixing
First mortar formulation (test 1) was with 130 mL deionized water--very dry mixture

APPENDIX B

Consistency—Portland Cement Mortar

1 Portland Cement: 0.5 Brick Dust: 2.5 Sand Trial #2

March 10, 2003 Temperature: 69.3°F Relative Humidity 32%

Material	Quantity	Instrument	Proportion (by volume)
Kempf Concrete Sand (sieved #4 ASTM)	500 mL	500 mL beaker	2.5
Brick dust	100 mL	200 mL beaker	0.5
Potland Cement	200 mL	300 mL beaker	1
Deionized Water	170 mL	2x 100 mL graduated cylinders	0.85

Test	Measurement 1 (in)	Measurement 2 (in)	Original Dimensions (in)	Difference Between Original and Measurement 1 (in)	Difference Between Original and Measurement 2 (in)
1	5.121	5.030	2.730	2.391	2.300
2	5.112	5.193	2.730	2.382	2.463
3	4.901	4.904	2.730	2.171	2.174

Average Difference for Measurement 1 (in)	Average Difference for Measurement 2 (in)
2.315	2.312

All materials at room temperature except Portland cement--stored outside (approx. 40 °F)
First layer in mold tamped 10 times, second layer tamped 20 times
Mortar remixed between tests 1, 2, and 3
Mortar briefly stuck to inverted trowel after mixing but quickly slid off

APPENDIX B

Consistency—Portland Cement Mortar

1 Portland Cement: 0.5 Brick Dust: 2.5 Sand Trial #3

March 10, 2003 Temperature: 68.8°F Relative Humidity 32%

Material	Quantity	Instrument	Proportion
Kempf Concrete Sand (sieved #4 ASTM)	500 mL	500 mL beaker	2.5
Brick dust	100 mL	200 mL beaker	0.5
Potland Cement	200 mL	300 mL beaker	1
Deionized Water	160 mL	2x 100 mL graduated cylinders	0.8

Test	Measurement 1 (in)	Measurement 2 (in)	Original Dimensions (in)	Difference Between Original and Measurement 1 (in)	Difference Between Original and Measurement 2 (in)
1	4.490	4.773	2.730	1.760	2.043
2	5.170	5.182	2.730	2.440	2.452
3	4.883	4.798	2.730	2.153	2.068

Average Difference for Measurement 1 (in)	Average Difference for Measurement 2 (in)
2.118	2.188

All materials at room temperature except Portland cement--stored outside (approx. 40 °F)
First layer in mold tamped 10 times, second layer tamped 20 times
Mortar remixed between tests 1, 2, and 3
Mortar stuck to inverted trowel after mixing

APPENDIX B

Consistency—Portland Cement Mortar

1 Portland Cement: 0.5 Brick Dust: 2.5 Sand Trial #4 (Retrial of 150mL mix water)

March 13, 2003 Temperature: 72.8°F Relative Humidity 34%

Material	Quantity	Instrument	Proportion
Kempf Concrete Sand (sieved #4 ASTM)	500 mL	500 mL beaker	2.5
Brick dust	100 mL	200 mL beaker	0.5
Potland Cement	200 mL	300 mL beaker	1
Deionized Water	150 mL	100 mL & 50 mL graduated cylinders	0.75

Test	Measurement 1 (in)	Measurement 2 (in)	Original Dimensions (in)	Difference Between Original and Measurement 1 (in)	Difference Between Original and Measurement 2 (in)
1	3.476	3.662	2.730	0.746	0.932
2	3.402	3.392	2.730	0.672	0.662
3	3.605	3.545	2.730	0.875	0.815

Average Difference for Measurement 1 (in)	Average Difference for Measurement 2 (in)
0.764	0.803

All materials at room temperature except Portland cement--stored outside (approx. 50 °F)
First layer in mold tamped 10 times, second layer tamped 20 times
Mortar remixed between tests 1, 2, and 3
Mortar briefly stuck to inverted trowel after mixing but quickly slid off
NOTE: Retrial of 150 mL mix water formulation originally performed on 3/10/03 (second part of Trial #1)

APPENDIX B

Water Retention—Lime Putty Mortar

1 Lime Putty: 0.5 Brick Dust: 2.5 Sand

March 14, 2003 Temperature: 71.2°F Relative Humidity 33%

Material	Quantity	Instrument	Proportion (by volume)
Kempf Concrete Sand (sieved #4 ASTM)	1000 mL	2 x 500 mL beakers	2.5
Brick dust	200 mL	200 mL beaker	0.5
Lime Putty	400 mL	500 mL beaker	1
Lime Water	100 mL	100 mL graduated cylinder	0.25

	mass of mold (g)	mass of filter paper (g)	mass of gauze (g)	mass of Plexiglas (g)	mass of mold, mortar, and Plexiglas (g)	mass of mortar in mold (g)
Test 1	75.77	5.35	4.08	144.63	586.09	365.69
Test 2	75.99	5.35	4.15	141.11	604.75	387.65
Test 3	76.08	5.32	3.76	147.01	589.28	366.19

	mass of filter paper/gauze with absorbed water (g)	mass of water absorbed (g)	percentage of water in mortar mixture (based on drying*)	mass of water in mortar in mold (g)	percentage of water in mortar after suction
Test 1	12.92	3.49	19%	69.59	94.99%
Test 2	12.44	2.94	19%	73.77	96.01%
Test 3	11.86	2.78	19%	69.69	96.01%

*Drying in 75 °C Oven:

mass of Plexiglas (g)	mass of Plexiglas and wet mortar (g)	mass of wet mortar (g)	mass of dry mortar and Plexiglas (g)	mass of dry mortar (g)	Percent moisture lost in drying
146.99	552.92	405.93	488.02	341.03	19.03%

Consistency:

Measurement 1 (in)	Measurement 2 (in)	Original Dimensions (in)	Difference Between Original and Measurement 1 (in)	Difference Between Original and Measurement 2 (in)
4.382	4.391	2.730	1.652	1.661

APPENDIX B

Water Retention—Natural Hydraulic Lime Mortar

1 Natural Hydraulic Lime: 0.5 Brick Dust: 2.5 Sand

March 11, 2003 Temperature: 74.1°F Relative Humidity 33%

Material	Quantity	Instrument	Proportion (by volume)
Kempf Concrete Sand (sieved #4 ASTM)	1000 mL	2 x 500 mL beakers	2.5
Brick dust	200 mL	200 mL beaker	0.5
Natural Hydraulic Lime	400 mL	500 mL beaker	1
Deionized Water	280 mL	300 mL beaker & 100 mL graduated cylinder	0.7

	mass of mold (g)	mass of filter paper (g)	mass of gauze (g)	mass of Plexiglas (g)	mass of mold, mortar, and Plexiglas (g)	mass of mortar in mold (g)
Test 1	76.19	5.39	2.51	144.60	591.55	370.76
Test 2	75.49	5.35	2.92	141.07	590.79	374.23
Test 3	76.08	5.36	3.22	146.90	589.34	366.36

	mass of filter paper/gauze with absorbed water (g)	mass of water absorbed (g)	percentage of water in mortar mixture (based on drying*)	mass of water in mortar in mold (g)	percentage of water in mortar after suction
Test 1	10.24	2.34	12%	43.91	94.67%
Test 2	10.93	2.66	12%	44.32	94.00%
Test 3	11.38	2.80	12%	43.39	93.55%

*Drying in 75 °C Oven:

mass of Plexiglas (g)	mass of Plexiglas and wet mortar (g)	mass of wet mortar (g)	mass of dry mortar and Plexiglas (g)	mass of dry mortar (g)	Percent moisture lost during drying
146.90	525.76	378.86	485.64	338.74	11.84%

Consistency:

Measurement 1 (in)	Measurement 2 (in)	Original Dimensions (in)	Difference Between Original and Measurement 1 (in)	Difference Between Original and Measurement 2 (in)
4.339	4.254	2.730	1.609	1.524

APPENDIX B

Water Retention—Portland Cement Mortar

1 Portland Cement: 0.5 Brick Dust: 2.5 Sand

March 13, 2003 Temperature: 72.8°F Relative Humidity 34%

Material	Quantity	Instrument	Proportion (by volume)
Kempf Concrete Sand (sieved #4 ASTM)	1000 mL	2 x 500 mL beakers	2.5
Brick dust	200 mL	200 mL beaker	0.5
Portland Cement	400 mL	500 mL beaker	1
Deionized Water	300 mL	300 mL beaker	0.75

	mass of mold (g)	mass of filter paper (g)	mass of gauze (g)	mass of Plexiglas (g)	mass of mold, mortar, and Plexiglas (g)	mass of mortar in mold (g)
Test 1	76.01	5.37	2.95	141.19	599.43	382.23
Test 2	76.05	5.29	2.18	144.64	594.98	374.29
Test 3	75.66	5.31	2.95	149.31	592.14	367.17

	mass of filter paper/gauze with absorbed water (g)	mass of water absorbed (g)	percentage of water in mortar mixture (based on drying*)	mass of water in mortar in mold (g)	percentage of water in mortar after suction
Test 1	8.75	0.43	10%	37.16	98.84%
Test 2	7.79	0.32	10%	36.39	99.12%
Test 3	8.62	0.36	10%	35.70	98.99%

*Drying in 75 °C Oven:

mass of Plexiglas (g)	mass of Plexiglas and wet mortar (g)	mass of wet mortar (g)	mass of dry mortar and Plexiglas (g)	mass of dry mortar (g)	Percent moisture lost during drying
149.21	518.91	369.70	486.15	336.94	9.72%

Consistency:

Measurement 1 (in)	Measurement 2 (in)	Original Dimensions (in)	Difference Between Original and Measurement 1 (in)	Difference Between Original and Measurement 2 (in)
3.055	2.850	2.730	0.325	0.120

APPENDIX B

Bleeding—Lime Putty Mortar

1 Lime Putty: 0.5 Brick Dust: 2.5 Sand

March 13, 2003 Temperature: 72.6°F Relative Humidity 34%

Material	Quantity	Instrument	Proportion (by volume)
Kempf Concrete Sand (sieved #4 ASTM)	2000 mL	4 x 500 mL beakers	2.5
Brick dust	400 mL	2 x 200 mL beakers	0.5
Lime Putty	800 mL	2 x 500 mL beakers	1
Lime Water	200 mL	2 x 100 mL graduated cylinders	0.25

Trial #1

Time	Time Elapsed (min)	Measurement (mL)	Temp (°F)	Relative Humidity	Cumulative Bleed Water (mL)
10:47 AM	0.00	0.000	72.6	34%	0.00
11:02 AM	15.00	0.200	72.3	34%	0.20
11:21 AM	34.00	0.500	72.1	34%	0.70
11:50 AM	63.00	0.800	72.7	34%	1.50
1:00 PM	133.00	1.000	72.9	34%	2.50
2:50 PM	243.00	0.700	73.3	34%	3.20
TOTAL	243.00	3.200	72.7	34%	3.20

Trial #2

Time	Time Elapsed (min)	Measurement (mL)	Temp (°F)	Relative Humidity	Cumulative Bleed Water (mL)
10:49 AM	0.00	0.000	72.6	34%	0.00
11:03 AM	14.00	0.000	72.3	34%	0.00
11:23 AM	34.00	0.200	72.1	34%	0.20
11:51 AM	62.00	0.700	72.7	34%	0.90
1:01 PM	132.00	1.000	72.9	34%	1.90
2:52 PM	243.00	0.800	73.3	34%	2.70
TOTAL	243.00	2.700	72.7	34%	2.70

APPENDIX B

Bleeding—Lime Putty Mortar

**1 Lime Putty: 0.5 Brick Dust: 2.5 Sand
(Continued)**

Trial #3

Time	Time Elapsed (min)	Measurement (mL)	Temp (°F)	Relative Humidity	Cumulative Bleed Water (mL)
10:50 AM	0.00	0.000	72.6	34%	0.00
11:05 AM	15.00	0.200	72.3	34%	0.20
11:25 AM	35.00	0.500	72.3	34%	0.70
11:52 AM	62.00	0.900	72.7	34%	1.60
1:01 PM	131.00	1.000	72.9	34%	2.60
2:53 PM	243.00	0.900	73.4	34%	3.50
TOTAL	243.00	3.500	72.7	34%	3.50

Trial #4

Time	Time Elapsed (min)	Measurement (mL)	Temp (°F)	Relative Humidity	Cumulative Bleed Water (mL)
10:52 AM	0.00	0.000	72.6	34%	0.00
11:07 AM	15.00	0.000	72.3	34%	0.00
11:26 AM	34.00	0.400	72.3	34%	0.40
11:52 AM	60.00	0.900	72.7	34%	1.30
1:02 PM	130.00	1.400	73.0	34%	2.70
2:55 PM	243.00	0.900	73.5	34%	3.60
TOTAL	243.00	3.600	72.7	34%	3.60

Trial #5

Time	Time Elapsed (min)	Measurement (mL)	Temp (°F)	Relative Humidity	Cumulative Bleed Water (mL)
10:53 AM	0.00	0.000	72.6	34%	0.00
11:07 AM	14.00	0.000	72.3	34%	0.00
11:26 AM	33.00	0.600	72.3	34%	0.60
11:53 AM	60.00	0.900	72.7	34%	1.50
1:04 PM	131.00	1.200	73.0	34%	2.70
2:56 PM	243.00	1.200	73.5	34%	3.90
TOTAL	243.00	3.900	72.7	34%	3.90

APPENDIX B

Bleeding—Natural Hydraulic Lime Mortar

1 Natural Hydraulic Lime: 0.5 Brick Dust: 2.5 Sand

March 14, 2003 Temperature: 71.4°F Relative Humidity 33%

Material	Quantity	Instrument	Proportion (by volume)
Kempf Concrete Sand (sieved #4 ASTM)	2000 mL	4 x 500 mL beakers	2.5
Brick dust	400 mL	2 x 200 mL beakers	0.5
Natural Hydraulic Lime	800 mL	2 x 500 mL beakers	1
Deionized Water	560 mL	500 mL beaker & 100 mL graduated cylinder	0.7

Trial #1

Time	Time Elapsed (min)	Measurement (mL)	Temp (°F)	Relative Humidity	Cumulative Bleed Water (mL)
2:02 PM	0.00	0.000	71.4	33%	0.00
2:16 PM	14.00	0.000	72.3	33%	0.00
2:30 PM	28.00	0.300	72.5	33%	0.30
2:59 PM	57.00	0.800	73.0	33%	1.10
4:13 PM	131.00	0.900	73.0	33%	2.00
6:01 PM	239.00	0.200	72.0	33%	2.20
TOTAL	239.00	2.200	72.4	33%	2.20

Trial #2

Time	Time Elapsed (min)	Measurement (mL)	Temp (°F)	Relative Humidity	Cumulative Bleed Water (mL)
2:03 PM	0.00	0.000	71.4	33%	0.00
2:16 PM	13.00	0.000	72.3	33%	0.00
2:31 PM	28.00	0.400	72.5	33%	0.40
3:00 PM	57.00	0.900	73.1	33%	1.30
4:14 PM	131.00	1.100	72.9	33%	2.40
6:02 PM	239.00	0.800	72.0	33%	3.20
TOTAL	239.00	3.200	72.4	33%	3.20

APPENDIX B

Bleeding—Natural Hydraulic Lime Mortar

**1 Natural Hydraulic Lime: 0.5 Brick Dust: 2.5 Sand
(Continued)**

Trial #3

Time	Time Elapsed (min)	Measurement (mL)	Temp (°F)	Relative Humidity	Cumulative Bleed Water (mL)
2:04 PM	0.00	0.000	71.4	33%	0.00
2:16 PM	12.00	0.000	72.3	33%	0.00
2:32 PM	28.00	0.200	72.6	33%	0.20
3:00 PM	56.00	0.700	73.1	33%	1.10
4:15 PM	131.00	1.000	72.9	33%	2.30
6:03 PM	239.00	0.400	72.1	33%	2.80
TOTAL	239.00	2.300	72.4	33%	2.80

Trial #4

Time	Time Elapsed (min)	Measurement (mL)	Temp (°F)	Relative Humidity	Cumulative Bleed Water (mL)
2:05 PM	0.00	0.000	71.4	33%	0.00
2:16 PM	11.00	0.000	72.3	33%	0.00
2:33 PM	28.00	0.400	72.5	33%	0.40
3:01 PM	56.00	0.800	73.2	33%	1.20
4:16 PM	131.00	1.000	72.9	33%	2.20
6:04 PM	239.00	0.200	72.1	33%	2.40
TOTAL	239.00	2.400	72.4	33%	2.40

Trial #5

Time	Time Elapsed (min)	Measurement (mL)	Temp (°F)	Relative Humidity	Cumulative Bleed Water (mL)
2:06 PM	0.00	0.000	71.4	33%	0.00
2:16 PM	10.00	0.000	72.3	33%	0.00
2:34 PM	28.00	0.400	72.5	33%	0.40
3:02 PM	56.00	0.700	73.2	33%	1.10
4:16 PM	130.00	0.900	72.9	33%	2.00
6:05 PM	239.00	0.300	72.1	33%	2.30
TOTAL	239.00	0.000	72.4	33%	2.30

APPENDIX B

Bleeding—Portland Cement Mortar

1 Portland Cement: 0.5 Brick Dust: 2.5 Sand

March 13, 2003 Temperature: 73.3°F Relative Humidity 34%

Material	Quantity	Instrument	Proportion (by volume)
Kempf Concrete Sand (sieved #4 ASTM)	2000 mL	4 x 500 mL beakers	2.5
Brick dust	400 mL	2 x 200 mL beakers	0.5
Portland Cement	800 mL	2 x 500 mL beakers	1
Deionized Water	600 mL	500 mL beaker & 100 mL graduated cylinder	0.75

Trial #1

Time	Time Elapsed (min)	Measurement (mL)	Temp (°F)	Relative Humidity	Cumulative Bleed Water (mL)
1:30 PM	0.00	0.000	73.3	34%	0.00
1:45 PM	15.00	0.400	73.1	34%	0.40
2:00 PM	30.00	0.800	73.2	34%	1.20
2:30 PM	60.00	1.000	73.5	34%	2.20
3:30 PM	120.00	0.400	73.3	34%	2.60
5:30 PM	240.00	0.000	72.4	34%	2.60
TOTAL	240.00	2.600	73.1	34%	2.60

Trial #2

Time	Time Elapsed (min)	Measurement (mL)	Temp (°F)	Relative Humidity	Cumulative Bleed Water (mL)
1:32 PM	0.00	0.000	73.3	34%	0.00
1:46 PM	14.00	0.400	73.1	34%	0.40
2:01 PM	29.00	1.000	73.3	34%	1.40
2:32 PM	60.00	1.100	73.5	34%	2.50
3:31 PM	119.00	0.600	73.3	34%	3.10
5:30 PM	238.00	0.000	72.4	34%	3.10
TOTAL	238.00	3.100	73.2	34%	3.10

APPENDIX B

Bleeding—Portland Cement Mortar

1 Portland Cement: 0.5 Brick Dust: 2.5 Sand (Continued)

Trial #3

Time	Time Elapsed (min)	Measurement (mL)	Temp (°F)	Relative Humidity	Cumulative Bleed Water (mL)
1:33 PM	0.00	0.000	73.3	34%	0.00
1:47 PM	14.00	0.400	73.1	34%	0.40
2:01 PM	28.00	0.800	73.3	34%	1.20
2:33 PM	60.00	0.900	73.5	34%	2.10
3:32 PM	119.00	0.200	73.4	34%	2.30
5:30 PM	237.00	0.000	72.4	34%	2.30
TOTAL	237.00	2.300	73.2	34%	2.30

Trial #4

Time	Time Elapsed (min)	Measurement (mL)	Temp (°F)	Relative Humidity	Cumulative Bleed Water (mL)
1:34 PM	0.00	0.000	73.3	34%	0.00
1:48 PM	14.00	0.300	73.1	34%	0.30
2:02 PM	28.00	0.800	73.3	34%	1.10
2:34 PM	60.00	1.000	73.5	34%	2.10
3:33 PM	119.00	0.400	73.5	34%	2.50
5:30 PM	236.00	0.000	72.4	34%	2.50
TOTAL	236.00	2.500	73.2	34%	2.50

Trial #5

Time	Time Elapsed (min)	Measurement (mL)	Temp (°F)	Relative Humidity	Cumulative Bleed Water (mL)
1:35 PM	0.00	0.000	73.3	34%	0.00
1:49 PM	14.00	0.400	73.1	34%	0.40
2:03 PM	28.00	0.900	73.3	34%	1.30
2:35 PM	60.00	0.800	73.5	34%	2.10
3:34 PM	119.00	0.100	73.5	34%	2.20
5:30 PM	235.00	0.000	72.4	34%	2.20
TOTAL	235.00	2.200	73.2	34%	2.20

APPENDIX B

Set Time—Lime Putty Mortar

I Lime Putty: 0.5 Brick Dust: 2.5 Sand

April 1, 2003 Temperature: 71.3°F Relative Humidity 33%

Material	Quantity	Instrument	Proportion (by volume)
Kempf Concrete Sand (sieved #4 ASTM)	500 mL	500 mL beaker	2.5
Brickdust	100 mL	200 mL beaker	0.5
Lime Putty	200 mL	300 mL beaker	1
Lime Water	50 mL	50 mL graduated cylinder	0.25

Trial #1

Date/Time	Time Elapsed (hours)	Measurement (mm)	Relative Humidity of container (%)
4/1/03 12:07 PM	0.00	38.0	33
4/2/03 11:37 AM	23.50	37.5	51
4/2/03 1:18 PM	25.18	39.0	48
4/2/03 10:10 PM	34.05	18.0	53
4/2/03 10:35 PM	34.47	21.0	51
4/2/03 11:10 PM	35.05	12.0	51
4/2/03 11:23 PM	35.27	1.5	50
4/2/03 11:40 PM	35.55	25.0	50
4/2/03 11:54 PM	35.78	24.0	50
4/3/03 9:01 AM	44.90	2.0	50
4/3/03 9:30 AM	45.38	0.5	51
4/3/03 9:49 AM	45.70	1.5	50
4/3/03 10:07 AM	46.00	2.0	51
4/3/03 10:36 AM	46.48	6.0	51
4/3/03 11:07 AM	47.00	0.0	51

APPENDIX B

Set Time (Continued)—Lime Putty Mortar

1 Lime Putty: 0.5 Brick Dust: 2.5 Sand

Trial #2

Date/Time	Time Elapsed (hours)	Measurement (mm)	Relative Humidity of container (%)
4/1/03 12:09 PM	0.00	40.0	33
4/2/03 11:38 AM	23.48	40.0	51
4/2/03 1:18 PM	25.15	40.0	48
4/2/03 10:12 PM	34.05	9.5	53
4/2/03 10:35 PM	34.43	33.5	51
4/2/03 11:10 PM	35.02	3.5	51
4/2/03 11:23 PM	35.23	24.0	50
4/2/03 11:40 PM	35.52	7.0	50
4/2/03 11:54 PM	35.75	7.5	50
4/3/03 9:01 AM	44.87	2.5	50
4/3/03 9:30 AM	45.35	2.5	51
4/3/03 9:50 AM	45.68	1.5	50
4/3/03 10:07 AM	45.97	1.5	51
4/3/03 10:36 AM	46.45	0.0	51

APPENDIX B

Set Time (Continued)—Lime Putty Mortar

1 Lime Putty: 0.5 Brick Dust: 2.5 Sand

Trial #3

Date/Time	Time Elapsed (hours)	Measurement (mm)	Relative Humidity of container (%)
4/1/03 12:09 PM	0.00	39.5	33
4/2/03 11:39 AM	23.50	22.0	51
4/2/03 1:19 PM	25.17	38.0	48
4/2/03 10:12 PM	34.05	33.5	53
4/2/03 10:35 PM	34.43	22.0	51
4/2/03 11:11 PM	35.03	3.0	51
4/2/03 11:24 PM	35.25	1.0	50
4/2/03 11:40 PM	35.52	25.0	50
4/2/03 11:54 PM	35.75	19.0	50
4/3/03 9:02 AM	44.88	1.0	50
4/3/03 9:31 AM	45.37	1.0	51
4/3/03 9:50 AM	45.68	1.0	50
4/3/03 10:08 AM	45.98	2.5	51
4/3/03 10:37 AM	46.47	0.5	51
4/3/03 11:08 AM	46.98	3.5	51
4/3/03 11:30 AM	47.35	0.0	55

APPENDIX B

Set Time—Natural Hydraulic Lime Mortar

1 Natural Hydraulic Lime: 0.5 Brick Dust: 2.5 Sand

March 28, 2003

Temperature: 70.9°F

Relative Humidity 33%

Material	Quantity	Instrument	Proportion (by volume)
Kempf Concrete Sand (sieved #4 ASTM)	1000 mL	2 x 500 mL beakers	2.5
Brick dust	200 mL	200 mL beaker	0.5
Natural Hydraulic Lime	400 mL	500 mL beaker	1
Deionized Water	280 mL	3 x 100 mL graduated cylinders	0.7

Trial #1

Date/Time	Time Elapsed (hours)	Measurement (mm)	Relative Humidity of container (%)
3/28/03 8:04 AM	0.00	39.0	33
3/28/03 1:18 PM	5.23	38.5	44
3/28/03 3:38 PM	7.57	27.5	54
3/28/03 4:39 PM	8.58	9.0	65
3/28/03 4:53 PM	8.82	12.0	54
3/28/03 5:07 PM	9.05	3.0	56
3/28/03 5:22 PM	9.30	3.0	54
3/28/03 5:38 PM	9.57	0.0	60

APPENDIX B

Set Time (Continued)—Natural Hydraulic Lime Mortar

I Natural Hydraulic Lime: 0.5 Brick Dust: 2.5 Sand

Trial #2

Date/Time	Time Elapsed (hours)	Measurement (mm)	Relative Humidity of container (%)
3/28/03 8:04 AM	0.00	39.0	33
3/28/03 1:18 PM	5.23	38.5	44
3/28/03 3:38 PM	7.57	19.5	54
3/28/03 4:40 PM	8.60	12.5	65
3/28/03 4:54 PM	8.83	10.0	54
3/28/03 5:07 PM	9.05	5.0	56
3/28/03 5:23 PM	9.32	4.5	54
3/28/03 5:38 PM	9.57	2.0	60
3/28/03 6:10 PM	10.10	0.0	62

Trial #3

Date/Time	Time Elapsed (hours)	Measurement (mm)	Relative Humidity of container (%)
3/28/03 8:05 AM	0.00	39.5	33
3/28/03 1:19 PM	5.23	39.5	44
3/28/03 3:39 PM	7.57	28.0	54
3/28/03 4:40 PM	8.58	11.0	65
3/28/03 4:55 PM	8.83	3.0	54
3/28/03 5:08 PM	9.05	2.5	56
3/28/03 5:23 PM	9.30	2.5	54
3/28/03 5:38 PM	9.55	0.0	60

APPENDIX B

Set Time—Portland Cement Mortar

1 Portland Cement: 0.5 Brick Dust: 2.5 Sand

April 2, 2003 Temperature: 72.5°F Relative Humidity 34%

Material	Quantity	Instrument	Proportion
Kempf Concrete Sand (sieved #4 ASTM)	500 mL	500 mL beaker	2.5
Brick dust	100 mL	200 mL beaker	0.5
Potland Cement	200 mL	300 mL beaker	1
Deionized Water	150 mL	100 mL & 50 mL graduated cylinders	0.75

Trial #1

Date/Time	Time Elapsed (hours)	Measurement (mm)	Relative Humidity of container (%)
4/2/03 12:01 PM	0.00	37.5	34
4/2/03 1:16 PM	1.25	37.0	48
4/2/03 2:57 PM	2.93	8.0	49
4/2/03 3:22 PM	3.35	12.0	45
4/2/03 3:37 PM	3.60	5.5	70
4/2/03 3:51 PM	3.83	12.5	48
4/2/03 4:12 PM	4.18	0.0	50

Trial #2

Date/Time	Time Elapsed (hours)	Measurement (mm)	Relative Humidity of container (%)
4/2/03 12:02 PM	0.00	37.0	34
4/2/03 1:17 PM	1.25	38.0	48
4/2/03 2:57 PM	2.92	3.5	49
4/2/03 3:23 PM	3.35	3.0	45
4/2/03 3:38 PM	3.60	6.5	70
4/2/03 3:52 PM	3.83	6.5	48
4/2/03 4:12 PM	4.17	1.0	50
4/2/03 4:27 PM	4.42	0.0	67

APPENDIX B

Set Time (Continued)—Portland Cement Mortar

1 Portland Cement: 0.5 Brick Dust: 2.5 Sand

Trial #3

Date/Time	Time Elapsed (hours)	Measurement (mm)	Relative Humidity of container (%)
4/2/03 12:03 PM	0.00	38.5	34
4/2/03 1:17 PM	1.23	38.0	48
4/2/03 2:58 PM	2.92	20.5	49
4/2/03 3:23 PM	3.33	5.0	45
4/2/03 3:38 PM	3.58	9.5	70
4/2/03 3:53 PM	3.83	0.0	48

APPENDIX C—FINISH POINTING MORTAR TESTS

Consistency—Lime Putty Mortar

1 Lime Putty: 3 Sand Mixture Trial #1

March 15, 2003 Temperature: 71.9°F Relative Humidity 34%

Material	Quantity	Instrument	Proportion (by volume)
Sand mixture	600 mL	2 x 300 mL beakers	3
Lime Putty	200 mL	300 mL beaker	1
Lime water	50 mL	50 mL graduated cylinder	0.25
	+ additional 20 mL (70 mL total)	20 mL graduated cylinder	0.35
	+ additional 30 mL (100 mL total)	50 mL graduated cylinder	0.5

Test	Measurement 1 (in)	Measurement 2 (in)	Original Dimensions (in)	Difference Between Original and Measurement 1 (in)	Difference Between Original and Measurement 2 (in)
1	n/a*	n/a*	2.730	n/a*	n/a*
2	n/a^	n/a^	2.730	n/a^	n/a^
3	6.045	6.901	2.730	3.315	4.171
3	4.736	4.764	2.730	2.006	2.034
4	4.582	4.517	2.73	1.852	1.787

Average Difference for Measurement 1 (in)	Average Difference for Measurement 2 (in)
2.391	2.664

All materials at room temperature

First layer in mold tamped 10 times, second layer tamped 20 times

*Test 1 was with 50 mL lime water (stuck briefly to inverted trowel--very dry); sheared after 2 drops

^Test 2 was with 70 mL lime water (stuck briefly to inverted trowel); sheared after 7 drops

Tests 3, 4, 5 made with 100 mL lime water (stuck briefly to inverted trowel--moist mixture)

APPENDIX C

Consistency—Lime Putty Mortar

1 Lime Putty: 3 Sand Mixture Trial #2

March 15, 2003 Temperature: 71.4°F Relative Humidity 34%

Material	Quantity	Instrument	Proportion (by volume)
Sand mixture	600 mL	2 x 300 mL beakers	3
Lime Putty	200 mL	300 mL beaker	1
Lime water	90 mL	100 mL graduated cylinder	0.45

Test	Measurement 1 (in)	Measurement 2 (in)	Original Dimensions (in)	Difference Between Original and Measurement 1 (in)	Difference Between Original and Measurement 2 (in)
1	5.042	5.160	2.730	2.312	2.430
2	5.286	5.205	2.730	2.556	2.475
3	5.356	5.396	2.73	2.626	2.666

Average Difference for Measurement 1 (in)	Average Difference for Measurement 2 (in)
2.498	2.524

All materials at room temperature
First layer in mold tamped 10 times, second layer tamped 20 times
Stuck to inverted trowel

APPENDIX C

Consistency—Lime Putty Mortar

1 Lime Putty: 3 Sand Mixture Trial #3

March 15, 2003 Temperature: 72.3°F Relative Humidity 34%

Material	Quantity	Instrument	Proportion (by volume)
Sand mixture	600 mL	2 x 300 mL beakers	3
Lime Putty	200 mL	300 mL beaker	1
Lime water	80 mL	100 mL graduated cylinder	0.4

Test	Measurement 1 (in)	Measurement 2 (in)	Original Dimensions (in)	Difference Between Original and Measurement 1 (in)	Difference Between Original and Measurement 2 (in)	Notes
1	3.394	3.423	2.730	0.664	0.693	
2	n/a	n/a	2.730	n/a	n/a	sheared, completely disintegrated in 8 drops
3	n/a	n/a	2.730	n/a	n/a	sheared, completely disintegrated in 8 drops

All materials at room temperature

First layer in mold tamped 10 times, second layer tamped 20 times

Stuck to inverted trowel, but very dry
--

APPENDIX C

Consistency—Lime Putty Mortar

1 Lime Putty: 3 Sand Mixture Trial #4

March 15, 2003 Temperature: 72.3°F Relative Humidity 34%

Material	Quantity	Instrument	Proportion (by volume)
Sand mixture	600 mL	2 x 300 mL beakers	3
Lime Putty	200 mL	300 mL beaker	1
Lime water	85 mL	100 mL graduated cylinder	0.425

Test	Measurement 1 (in)	Measurement 2 (in)	Original Dimensions (in)	Difference Between Original and Measurement 1 (in)	Difference Between Original and Measurement 2 (in)
1	3.985	4.057	2.730	1.255	1.327
2	4.231	4.316	2.730	1.501	1.586
3	3.789	3.831	2.73	1.059	1.101

Average Difference for Measurement 1 (in)	Average Difference for Measurement 2 (in)
1.272	1.338

All materials at room temperature
First layer in mold tamped 10 times, second layer tamped 20 times
Stuck to inverted trowel

APPENDIX C

Consistency—Natural Hydraulic Lime Mortar

1 Natural Hydraulic Lime: 3 Sand Mixture Trial #1

March 15, 2003 Temperature: 69.2°F Relative Humidity 34%

Material	Quantity	Instrument	Proportion (by volume)
Sand mixture	600 mL	2 x 300 mL beakers	3
Natural Hydraulic Lime	200 mL	300 mL beaker	1
Deionized Water	150 mL	100 mL & 50 mL graduated cylinders	0.75
	+ additional 20 mL (170 mL total)	50 mL graduated cylinder	0.85

Test	Measurement 1 (in)	Measurement 2 (in)	Original Dimensions (in)	Difference Between Original and Measurement 1 (in)	Difference Between Original and Measurement 2 (in)	Notes
1	n/a*	n/a*	n/a*	n/a*	n/a*	sheared off after 10 drops
2	5.136	5.279	2.730	2.406	2.549	
3	5.200	5.474	2.730	2.470	2.744	
4	4.659	4.647	2.730	1.929	1.917	

Average Difference for Measurement 1 (in)	Average Difference for Measurement 2 (in)
2.268	2.403

All materials at room temperature except HHL--stored outside (approx. 40 °F)
First layer in mold tamped 10 times, second layer tamped 20 times
*Test 1 had total of 150 mL water--completely disintegrated after 10 drops
Tests 2, 3, and 4 had a total of 170 mL water--briefly stuck to inverted trowel

APPENDIX C

Consistency—Natural Hydraulic Lime Mortar

1 Natural Hydraulic Lime: 3 Sand Mixture Trial #2

March 15, 2003 Temperature: 70.1°F Relative Humidity 34%

Material	Quantity	Instrument	Proportion (by volume)
Sand mixture	600 mL	2 x 300 mL beakers	3
Natural Hydraulic Lime	200 mL	300 mL beaker	1
Deionized Water	160 mL	2 x 100 mL graduated cylinders	0.8

Test	Measurement 1 (in)	Measurement 2 (in)	Original Dimensions (in)	Difference Between Original and Measurement 1 (in)	Difference Between Original and Measurement 2 (in)
1	4.857	5.042	2.730	2.127	2.312
2	4.851	4.822	2.730	2.121	2.092
3	4.567	4.627	2.730	1.837	1.897

Average Difference for Measurement 1 (in)	Average Difference for Measurement 2 (in)
2.028	2.100

All materials at room temperature except HHL--stored outside (approx. 40 °F)
First layer in mold tamped 10 times, second layer tamped 20 times
Stuck to inverted trowel

APPENDIX C

Consistency—Natural Hydraulic Lime Mortar

1 Natural Hydraulic Lime: 3 Sand Mixture Trial #3

March 15, 2003 Temperature: 70.8°F Relative Humidity 34%

Material	Quantity	Instrument	Proportion (by volume)
Sand mixture	600 mL	2 x 300 mL beakers	3
Natural Hydraulic Lime	200 mL	300 mL beaker	1
Deionized Water	155 mL	100 mL, 50 mL & 10 mL graduated cylinders	0.775

Test	Measurement 1 (in)	Measurement 2 (in)	Original Dimensions (in)	Difference Between Original and Measurement 1 (in)	Difference Between Original and Measurement 2 (in)
1	4.553	4.602	2.730	1.823	1.872
2	4.436	4.624	2.730	1.706	1.894
3	4.115	4.432	2.730	1.385	1.702

Average Difference for Measurement 1 (in)	Average Difference for Measurement 2 (in)
1.638	1.823

All materials at room temperature except HHL--stored outside (approx. 40 °F)
First layer in mold tamped 10 times, second layer tamped 20 times
Stuck to inverted trowel

APPENDIX C

Consistency—Portland Cement Mortar

1 Portland Cement: 3 Sand Mixture Trial #1

March 15, 2003 Temperature: 72.6°F Relative Humidity 34%

Material	Quantity	Instrument	Proportion (by volume)
Sand mixture	600 mL	2 x 300 mL beakers	3
Portland Cement	200 mL	300 mL beaker	1
Deionized water	180 mL	2 x 100 mL graduated cylinders	0.9

Test	Measurement 1 (in)	Measurement 2 (in)	Original Dimensions (in)	Difference Between Original and Measurement 1 (in)	Difference Between Original and Measurement 2 (in)
1	5.387	5.648	2.730	2.657	2.918
2	5.147	5.068	2.730	2.417	2.338
3	4.584	4.462	2.73	1.854	1.732

Average Difference for Measurement 1 (in)	Average Difference for Measurement 2 (in)
2.309	2.329

All materials at room temperature except Portland cement--stored at approx 50 °F
First layer in mold tamped 10 times, second layer tamped 20 times
Stuck briefly to inverted trowel before sliding off

APPENDIX C

Consistency—Portland Cement Mortar

1 Portland Cement: 3 Sand Mixture Trial #2

March 15, 2003 Temperature: 72.8°F Relative Humidity 34%

Material	Quantity	Instrument	Proportion (by volume)
Sand mixture	600 mL	2 x 300 mL beakers	3
Portland Cement	200 mL	300 mL beaker	1
Deionized water	160 mL	2 x 100 mL graduated cylinders	0.8
	+ additional 10 mL (170 mL total)	10 mL graduated cylinder	0.85

Test	Measurement 1 (in)	Measurement 2 (in)	Original Dimensions (in)	Difference Between Original and Measurement 1 (in)	Difference Between Original and Measurement 2 (in)	Notes
1	n/a*	n/a*	2.730	n/a*	n/a*	completely broke apart after 4 drops
2	n/a^	n/a^	2.730	n/a^	n/a^	completely broke apart after 10 drops

All materials at room temperature except Portland cement--stored at approx 50 °F

First layer in mold tamped 10 times, second layer tamped 20 times

*Test 1 (total of 160 mL mix water) did not stick to inverted trowel

^Test 2 (total of 170 mL water) did not stick to inverted trowel

APPENDIX C

Consistency—Portland Cement Mortar

1 Portland Cement: 3 Sand Mixture Trial #3

March 18, 2003 Temperature: 71.4°F Relative Humidity 34%

Material	Quantity	Instrument	Proportion (by volume)
Sand mixture	600 mL	2 x 300 mL beakers	3
Portland Cement	200 mL	300 mL beaker	1
Deionized water	175 mL	2 x 100 mL graduated cylinders	0.875

Test	Measurement 1 (in)	Measurement 2 (in)	Original Dimensions (in)	Difference Between Original and Measurement 1 (in)	Difference Between Original and Measurement 2 (in)
1	3.965	4.016	2.730	1.235	1.286
2	3.739	3.692	2.730	1.009	0.962
3	3.776	3.969	2.73	1.046	1.239

Average Difference for Measurement 1 (in)	Average Difference for Measurement 2 (in)
1.097	1.162

All materials at room temperature except Portland cement--stored at approx 60°F

First layer in mold tamped 10 times, second layer tamped 20 times

Stuck briefly to inverted trowel before sliding off

APPENDIX C

Water Retention—Lime Putty Mortar

I Lime Putty: 3 Sand Mixture

March 19, 2003 Temperature: 69.0°F Relative Humidity 34%

Material	Quantity	Instrument	Proportion (by volume)
Sand mixture	1200 mL	3 x 500 mL beakers	3
Lime Putty	400 mL	500 mL beaker	1
Lime Water	170 mL	2 x 100 mL graduated cylinders	0.425

	mass of mold (g)	mass of filter paper (g)	mass of gauze (g)	mass of Plexiglas (g)	mass of mold, mortar, and Plexiglas (g)	mass of mortar in mold (g)
Test 1	76.07	5.42	2.39	146.88	587.72	364.77
Test 2	75.66	5.41	2.93	149.08	585.59	360.85
Test 3	75.93	5.45	2.13	148.72	569.39	344.74

	mass of filter paper/gauze with absorbed water (g)	mass of water absorbed (g)	percentage of water in mortar mixture (based on drying*)	mass of water in mortar in mold (g)	percentage of water in mortar after suction
Test 1	13.10	5.29	22%	82.06	93.55%
Test 2	12.44	4.10	22%	81.18	94.95%
Test 3	10.95	3.37	22%	77.56	95.65%

*Drying in 75 °C Oven:

mass of Plexiglas (g)	mass of Plexiglas and wet mortar (g)	mass of wet mortar (g)	mass of dry mortar and Plexiglas (g)	mass of dry mortar (g)	Percent moisture lost during drying
148.95	526.56	377.61	457.21	308.26	22.50%

Consistency

Measurement 1 (in)	Measurement 2 (in)	Original Dimensions (in)	Difference Between Original and Measurement 1 (in)	Difference Between Original and Measurement 2 (in)
5.667	5.506	2.730	2.937	2.776

APPENDIX C

Water Retention—Natural Hydraulic Lime Mortar

1 Natural Hydraulic Lime: 3 Sand Mixture

March 18, 2003 Temperature: 70.6°F Relative Humidity 34%

Material	Quantity	Instrument	Proportion (by volume)
Sand mixture	1200 mL	3 x 500 mL beakers	3
Natural Hydraulic Lime	400 mL	500 mL beaker	1
Deionized water	310 mL	500 mL beaker & 10 mL graduated cylinder	0.775

	mass of mold (g)	mass of filter paper (g)	mass of gauze (g)	mass of Plexiglas (g)	mass of mold, mortar, and Plexiglas (g)	mass of mortar in mold (g)
Test 1	76.20	5.38	3.36	148.79	584.90	359.91
Test 2	75.50	5.45	3.24	149.00	565.65	341.15
Test 3	75.91	5.42	2.58	141.12	565.63	348.60

	mass of filter paper/gauze with absorbed water (g)	mass of water absorbed (g)	percentage of water in mortar mixture (based on drying*)	mass of water in mortar in mold (g)	percentage of water in mortar after suction
Test 1	11.81	3.07	13%	47.57	93.55%
Test 2	10.23	1.54	13%	45.09	96.58%
Test 3	9.91	1.91	13%	46.07	95.85%

*Drying in 75 °C Oven:

mass of Plexiglas (g)	mass of Plexiglas and wet mortar (g)	mass of wet mortar (g)	mass of dry mortar and Plexiglas (g)	mass of dry mortar (g)	Percent moisture lost during drying
141.14	489.63	348.49	448.95	307.81	13.22%

Consistency

Measurement 1 (in)	Measurement 2 (in)	Original Dimensions (in)	Difference Between Original and Measurement 1 (in)	Difference Between Original and Measurement 2 (in)
4.098	4.180	2.730	1.368	1.450

APPENDIX C

Water Retention—Portland Cement Mortar

1 Portland Cement: 3 Sand Mixture

March 18, 2003 Temperature: 71.4°F Relative Humidity 34%

Material	Quantity	Instrument	Proportion (by volume)
Sand mixture	1200 mL	3 x 500 mL beakers	3
Portland Cement	400 mL	500 mL beaker	1
Deionized water	350 mL	500 mL beaker & 50 mL graduated cylinder	0.875

	mass of mold (g)	mass of filter paper (g)	mass of gauze (g)	mass of Plexiglas (g)	mass of mold, mortar, and Plexiglas (g)	mass of mortar in mold (g)
Test 1	75.50	5.48	3.41	149.05	598.78	374.23
Test 2	75.90	5.44	3.40	141.20	604.98	387.88
Test 3	76.14	5.41	3.26	144.65	596.89	376.10

	mass of filter paper/gauze with absorbed water (g)	mass of water absorbed (g)	percentage of water in mortar mixture (based on drying*)	mass of water in mortar in mold (g)	percentage of water in mortar after suction
Test 1	9.65	0.76	12%	44.54	98.29%
Test 2	10.16	1.32	12%	46.16	97.14%
Test 3	10.11	1.44	12%	44.76	96.78%

*Drying in 75 °C Oven:

mass of Plexiglas (g)	mass of Plexiglas and wet mortar (g)	mass of wet mortar (g)	mass of dry mortar and Plexiglas (g)	mass of dry mortar (g)	Percent moisture lost during drying
144.68	533.09	388.41	491.78	347.10	11.90%

Consistency

Measurement 1 (in)	Measurement 2 (in)	Original Dimensions (in)	Difference Between Original and Measurement 1 (in)	Difference Between Original and Measurement 2 (in)
3.093	3.108	2.730	0.363	0.378

APPENDIX C

Bleeding—Lime Putty Mortar

1 Lime Putty: 3 Sand Mixture

March 19, 2003 Temperature: 70.1°F Relative Humidity 34%

Material	Quantity	Instrument	Proportion (by volume)
Sand mixture	2400 mL	5 x 500 mL beakers	3
Lime Putty	800 mL	2 x 500 mL beakers	1
Lime water	340 mL	300 mL beaker & 50 mL graduated cylinder	0.425

Trial #1

Time	Time Elapsed (min)	Measurement (mL)	Temp (°F)	Relative Humidity	Cumulative Bleed Water (mL)
3:25 PM	0.00	0.000	70.1	34%	0.00
3:40 PM	15.00	0.300	70.2	34%	0.30
3:55 PM	30.00	0.600	70.3	34%	0.90
4:29 PM	64.00	1.200	70.1	34%	2.10
5:31 PM	126.00	1.400	69.9	34%	3.50
7:29 PM	244.00	1.200	69.0	34%	4.70
TOTAL	244.00	4.700	69.9	34%	4.70

Trial #2

Time	Time Elapsed (min)	Measurement (mL)	Temp (°F)	Relative Humidity	Cumulative Bleed Water (mL)
3:27 PM	0.00	0.000	70.1	34%	0.00
3:41 PM	14.00	0.100	70.2	34%	0.10
3:56 PM	29.00	0.500	70.3	34%	0.60
4:30 PM	63.00	0.800	70.1	34%	1.40
5:32 PM	125.00	0.800	69.9	34%	2.20
7:30 PM	243.00	0.500	69.0	34%	2.70
TOTAL	243.00	2.700	69.9	34%	2.70

APPENDIX C

Bleeding—Lime Putty Mortar (Continued)

1 Lime Putty: 3 Sand Mixture

Trial #3

Time	Time Elapsed (min)	Measurement (mL)	Temp (°F)	Relative Humidity	Cumulative Bleed Water (mL)
3:28 PM	0.00	0.000	70.1	34%	0.00
3:42 PM	14.00	0.050	70.2	34%	0.05
3:57 PM	29.00	0.400	70.3	34%	0.45
4:30 PM	62.00	1.200	70.1	34%	1.65
5:33 PM	125.00	1.000	69.9	34%	2.65
7:31 PM	243.00	0.700	69.0	34%	3.35
TOTAL	243.00	3.350	69.9	34%	3.35

Trial #4

Time	Time Elapsed (min)	Measurement (mL)	Temp (°F)	Relative Humidity	Cumulative Bleed Water (mL)
3:29 PM	0.00	0.000	70.1	34%	0.00
3:43 PM	14.00	0.025	70.2	34%	0.03
3:58 PM	29.00	0.300	70.3	34%	0.33
4:31 PM	62.00	0.700	70.1	34%	1.03
5:35 PM	126.00	1.000	69.9	34%	2.03
7:32 PM	243.00	0.600	69.0	34%	2.63
TOTAL	243.00	2.625	69.9	34%	2.63

Trial #5

Time	Time Elapsed (min)	Measurement (mL)	Temp (°F)	Relative Humidity	Cumulative Bleed Water (mL)
3:30 PM	0.00	0.000	70.1	34%	0.00
3:44 PM	14.00	0.000	70.2	34%	0.00
3:59 PM	29.00	0.300	70.3	34%	0.30
4:32 PM	62.00	0.700	70.1	34%	1.00
5:35 PM	125.00	0.600	69.9	34%	1.60
7:33 PM	243.00	0.300	69.0	34%	1.90
TOTAL	243.00	0.000	69.9	34%	1.90

APPENDIX C

Bleeding—Natural Hydraulic Lime Mortar

1 Natural Hydraulic Lime: 3 Sand Mixture

March 15, 2003 Temperature: 71.8°F Relative Humidity 34%

Material	Quantity	Instrument	Proportion (by volume)
Sand mixture	2400 mL	5 x 500 mL beakers	3
Natural Hydraulic Lime	800 mL	2 x 500 mL beakers	1
Deionized Water	620 mL	500 mL beaker, 100 mL & 50 mL graduated cylinders	0.775

Trial #1

Time	Time Elapsed (min)	Measurement (mL)	Temp (°F)	Relative Humidity	Cumulative Bleed Water (mL)
12:01 PM	0.00	0.000	71.8	34%	0.00
12:16 PM	15.00	0.000	71.7	34%	0.00
12:31 PM	30.00	0.000	72.0	34%	0.00
1:00 PM	59.00	0.200	71.7	34%	0.20
1:58 PM	117.00	0.100	71.9	34%	0.30
4:00 PM	239.00	0.050	73.1	34%	0.35
TOTAL	239.00	0.350	72.0	34%	0.35

Trial #2

Time	Time Elapsed (min)	Measurement (mL)	Temp (°F)	Relative Humidity	Cumulative Bleed Water (mL)
12:03 PM	0.00	0.000	71.8	34%	0.00
12:16 PM	13.00	0.000	71.7	34%	0.00
12:32 PM	29.00	0.050	72.0	34%	0.05
1:01 PM	58.00	0.200	71.6	34%	0.25
1:59 PM	116.00	0.200	71.9	34%	0.45
4:00 PM	237.00	0.100	73.2	34%	0.55
TOTAL	237.00	0.550	72.0	34%	0.55

APPENDIX C

Bleeding—Natural Hydraulic Lime Mortar (Continued)

1 Natural Hydraulic Lime: 3 Sand Mixture

Trial #3

Time	Time Elapsed (min)	Measurement (mL)	Temp (°F)	Relative Humidity	Cumulative Bleed Water (mL)
12:05 PM	0.00	0.000	71.8	34%	0.00
12:16 PM	11.00	0.000	71.7	34%	0.00
12:33 PM	28.00	0.000	72.0	34%	0.00
1:02 PM	57.00	0.200	71.6	34%	0.20
2:00 PM	115.00	0.300	71.9	34%	0.50
4:01 PM	236.00	0.075	73.2	34%	0.58
TOTAL	236.00	0.575	72.0	34%	0.58

Trial #4

Time	Time Elapsed (min)	Measurement (mL)	Temp (°F)	Relative Humidity	Cumulative Bleed Water (mL)
12:06 PM	0.00	0.000	71.8	34%	0.00
12:16 PM	10.00	0.000	71.7	34%	0.00
12:33 PM	27.00	0.050	72.0	34%	0.05
1:04 PM	58.00	0.050	71.6	34%	0.10
2:01 PM	115.00	0.100	72.0	34%	0.20
4:02 PM	236.00	0.025	73.2	34%	0.23
TOTAL	236.00	0.225	72.1	34%	0.23

Trial #5

Time	Time Elapsed (min)	Measurement (mL)	Temp (°F)	Relative Humidity	Cumulative Bleed Water (mL)
12:07 PM	0.00	0.000	71.8	34%	0.00
12:16 PM	9.00	0.000	71.7	34%	0.00
12:33 PM	26.00	0.000	72.0	34%	0.00
1:05 PM	58.00	0.100	71.5	34%	0.10
2:02 PM	115.00	0.200	72.0	34%	0.30
4:02 PM	235.00	0.025	73.2	34%	0.33
TOTAL	235.00	0.000	72.0	34%	0.33

APPENDIX C

Bleeding—Portland Cement Mortar

1 Portland Cement: 3 Sand Mixture

March 19, 2003 Temperature: 66.6°F Relative Humidity 33%

Material	Quantity	Instrument	Proportion (by volume)
Sand mixture	2400 mL	5 x 500 mL beakers	3
Portland Cement	800 mL	2 x 500 mL beakers	1
Deionized Water	700 mL	500 mL & 200 mL beakers	0.875

Trial #1

Time	Time Elapsed (min)	Measurement (mL)	Temp (°F)	Relative Humidity	Cumulative Bleed Water (mL)
11:40 AM	0.00	0.000	66.6	33%	0.00
11:57 AM	17.00	0.000	67.2	34%	0.00
12:14 PM	34.00	0.000	66.7	34%	0.00
12:40 PM	60.00	0.400	66.6	34%	0.40
1:35 PM	115.00	0.100	66.8	34%	0.50
3:39 PM	239.00	0.000	70.2	34%	0.50
TOTAL	239.00	0.500	67.4	34%	0.50

Trial #2

Time	Time Elapsed (min)	Measurement (mL)	Temp (°F)	Relative Humidity	Cumulative Bleed Water (mL)
11:41 AM	0.00	0.000	66.6	33%	0.00
11:57 AM	16.00	0.000	67.2	34%	0.00
12:14 PM	33.00	0.000	66.7	34%	0.00
12:41 PM	60.00	0.050	66.6	34%	0.05
1:35 PM	114.00	0.000	66.8	34%	0.05
3:39 PM	238.00	0.000	70.2	34%	0.05
TOTAL	238.00	0.050	67.4	34%	0.05

APPENDIX C

Bleeding—Portland Cement Mortar (Continued)

1 Portland Cement: 3 Sand Mixture

Trial #3

Time	Time Elapsed (min)	Measurement (mL)	Temp (°F)	Relative Humidity	Cumulative Bleed Water (mL)
11:43 AM	0.00	0.000	66.6	33%	0.00
11:57 AM	14.00	0.000	67.2	34%	0.00
12:14 PM	31.00	0.200	66.7	34%	0.20
12:42 PM	59.00	0.800	66.6	34%	1.00
1:35 PM	112.00	0.200	66.8	34%	1.20
3:39 PM	236.00	0.000	70.2	34%	1.20
TOTAL	236.00	1.200	67.4	34%	1.20

Trial #4

Time	Time Elapsed (min)	Measurement (mL)	Temp (°F)	Relative Humidity	Cumulative Bleed Water (mL)
11:45 AM	0.00	0.000	66.6	33%	0.00
11:57 AM	12.00	0.000	67.2	34%	0.00
12:15 PM	30.00	0.000	66.7	34%	0.00
12:44 PM	59.00	0.100	66.6	34%	0.10
1:36 PM	111.00	0.025	66.8	34%	0.13
3:39 PM	234.00	0.000	70.2	34%	0.13
TOTAL	234.00	0.125	67.4	34%	0.13

Trial #5

Time	Time Elapsed (min)	Measurement (mL)	Temp (°F)	Relative Humidity	Cumulative Bleed Water (mL)
11:46 AM	0.00	0.000	66.6	33%	0.00
11:57 AM	11.00	0.000	67.2	34%	0.00
12:15 PM	29.00	0.000	66.7	34%	0.00
12:44 PM	58.00	0.000	66.6	34%	0.00
1:36 PM	110.00	0.000	66.8	34%	0.00
3:39 PM	233.00	0.000	70.2	34%	0.00
TOTAL	233.00	0.000	67.4	34%	0.00

APPENDIX C

Set Time—Lime Putty Mortar

1 Lime Putty: 3 Sand Mixture

March 25, 2003 Temperature: 70.4°F Relative Humidity 34%

Material	Quantity	Instrument	Proportion (by volume)
Sand mixture	600 mL	2 x 300 mL beakers	3
Lime Putty	200 mL	300 mL beaker	1
Lime water	85 mL	100 mL graduated cylinder	0.425

Trial #1

Date/Time	Time Elapsed (hours)	Measurement (mm)	Relative Humidity of container (%)
3/25/03 5:30 PM	0.00	42.0	34
3/26/03 12:12 PM	18.70	40.0	50
3/27/03 1:34 PM	44.07	38.0	80
3/27/03 4:08 PM	46.63	38.0	42
3/27/03 6:44 PM	49.23	38.0	75
3/27/03 9:45 PM	52.25	37.5	45
3/27/03 11:10 PM	53.67	38.0	49
3/27/03 11:53 PM	54.38	38.5	50
3/28/03 12:17 AM	54.78	38.5	50
3/28/03 7:42 AM	62.20	11.5	44
3/28/03 10:21 AM	64.85	12.0	48
3/28/03 11:10 AM	65.67	2.0	52
3/28/03 11:45 AM	66.25	2.0	42
3/28/03 12:40 PM	67.17	0.0	70

APPENDIX C

Set Time—Lime Putty Mortar (Continued)

1 Lime Putty: 3 Sand Mixture

Trial #2

Date/Time	Time Elapsed (hours)	Measurement (mm)	Relative Humidity of container (%)
3/25/03 5:31 PM	0.00	38.0	34
3/26/03 12:12 PM	18.68	38.0	50
3/27/03 1:34 PM	44.05	37.5	80
3/27/03 4:09 PM	46.63	38.0	42
3/27/03 6:45 PM	49.23	22.0	75
3/27/03 9:45 PM	52.23	19.0	45
3/27/03 11:12 PM	53.68	7.5	49
3/27/03 11:53 PM	54.37	9.5	50
3/28/03 12:18 AM	54.78	18.5	50
3/28/03 7:42 AM	62.18	1.0	44
3/28/03 10:22 AM	64.85	3.0	48
3/28/03 11:11 AM	65.67	0.5	52
3/28/03 11:45 AM	66.23	5.0	42
3/28/03 12:40 PM	67.15	0.0	70

APPENDIX C

Set Time—Lime Putty Mortar (Continued)

1 Lime Putty: 3 Sand Mixture

Trial #3

Date/Time	Time Elapsed (hours)	Measurement (mm)	Relative Humidity of container (%)
3/25/03 5:32 PM	0.00	40.0	34
3/26/03 12:13 PM	18.68	39.0	50
3/27/03 1:35 PM	44.05	38.0	80
3/27/03 4:09 PM	46.62	38.0	42
3/27/03 6:45 PM	49.22	38.0	75
3/27/03 9:46 PM	52.23	38.0	45
3/27/03 11:12 PM	53.67	38.0	49
3/27/03 11:54 PM	54.37	39.0	50
3/28/03 12:19 AM	54.78	39.0	50
3/28/03 7:43 AM	62.18	38.5	44
3/28/03 10:23 AM	64.85	22.0	48
3/28/03 11:11 AM	65.65	27.5	52
3/28/03 11:46 AM	66.23	38.5	42
3/28/03 12:41 PM	67.15	20.5	70
3/28/03 1:20 PM	67.80	25.5	44
3/28/03 3:37 PM	70.08	3.0	54
3/28/03 4:39 PM	71.12	23.0	65
3/28/03 5:10 PM	71.63	14.5	56
3/28/03 5:39 PM	72.12	22.5	60
3/29/03 3:15 PM	93.72	0.5	65
3/29/03 5:45 PM	96.22	0.0	65

APPENDIX C

Set Time—Natural Hydraulic Lime Mortar

1 Natural Hydraulic Lime: 3 Sand Mixture

March 25, 2003 Temperature: 70.2°F Relative Humidity 34%

Material	Quantity	Instrument	Proportion (by volume)
Sand mixture	600 mL	2 x 300 mL beakers	3
Natural Hydraulic Lime	200 mL	300 mL beaker	1
Deionized Water	155 mL	100 mL, 50 mL & 10 mL graduated cylinders	0.775

Trial #1

Date/Time	Time Elapsed (hours)	Measurement (mm)	Relative Humidity of container (%)
3/25/03 11:39 AM	0.00	39.0	34
3/25/03 3:21 PM	3.70	38.0	60
3/25/03 4:17 PM	4.63	38.0	50
3/25/03 6:20 PM	6.68	38.5	49
3/25/03 7:19 PM	7.67	38.0	48
3/25/03 8:04 PM	8.42	38.5	50
3/25/03 9:10 PM	9.52	33.5	52
3/25/03 9:58 PM	10.32	21.5	58
3/25/03 10:27 PM	10.80	22.0	50
3/25/03 11:02 PM	11.38	11.0	55
3/25/03 11:18 PM	11.65	11.5	50
3/25/03 11:43 PM	12.07	4.0	52
3/26/03 12:00 AM	12.35	3.0	50
3/26/03 12:15 AM	12.60	3.0	50
3/26/03 12:30 AM	12.85	1.0	50
3/26/03 12:44 AM	13.08	1.0	51
3/26/03 12:52 AM	13.22	0.0	50

APPENDIX C

Set Time—Natural Hydraulic Lime Mortar (Continued)

1 Natural Hydraulic Lime: 3 Sand Mixture

Trial #2

Date/Time	Time Elapsed (hours)	Measurement (mm)	Relative Humidity of container (%)
3/25/03 11:40 AM	0.00	37.0	34
3/25/03 3:21 PM	3.68	37.5	60
3/25/03 4:17 PM	4.62	37.5	50
3/25/03 6:20 PM	6.67	38.0	49
3/25/03 7:19 PM	7.65	37.5	48
3/25/03 8:04 PM	8.40	7.4	50
3/25/03 9:10 PM	9.50	24.0	52
3/25/03 9:59 PM	10.32	15.5	58
3/25/03 10:28 PM	10.80	12.5	50
3/25/03 11:03 PM	11.38	19.0	55
3/25/03 11:19 PM	11.65	13.0	50
3/25/03 11:43 PM	12.05	2.5	52
3/26/03 12:00 AM	12.33	4.0	50
3/26/03 12:15 AM	12.58	1.5	50
3/26/03 12:30 AM	12.83	3.0	50
3/26/03 12:45 AM	13.08	2.5	51
3/26/03 12:53 AM	13.22	1.0	50
3/26/03 1:04 AM	13.40	0.0	50

APPENDIX C

Set Time—Natural Hydraulic Lime Mortar (Continued)

I Natural Hydraulic Lime: 3 Sand Mixture

Trial #3

Date/Time	Time Elapsed (hours)	Measurement (mm)	Relative Humidity of container (%)
3/25/03 11:40 AM	0.00	38.5	34
3/25/03 3:22 PM	3.70	38.5	60
3/25/03 4:18 PM	4.63	38.0	50
3/25/03 6:21 PM	6.68	38.0	49
3/25/03 7:19 PM	7.65	33.5	48
3/25/03 8:05 PM	8.42	38.0	50
3/25/03 9:10 PM	9.50	37.0	52
3/25/03 10:00 PM	10.33	12.5	58
3/25/03 10:29 PM	10.82	15.0	50
3/25/03 11:04 PM	11.40	10.0	55
3/25/03 11:20 PM	11.67	7.5	50
3/25/03 11:44 PM	12.07	5.0	52
3/26/03 12:00 AM	12.33	2.0	50
3/26/03 12:15 AM	12.58	2.0	50
3/26/03 12:31 AM	12.85	2.5	50
3/26/03 12:45 AM	13.08	3.5	51
3/26/03 12:54 AM	13.23	3.0	50
3/26/03 1:00 AM	13.33	0.0	50

APPENDIX C

Set Time—Portland Cement Mortar

1 Portland Cement: 3 Sand Mixture

March 25, 2003 Temperature: 70.9°F Relative Humidity 34%

Material	Quantity	Instrument	Proportion (by volume)
Sand mixture	600 mL	2 x 300 mL beakers	3
Portland Cement	200 mL	300 mL beaker	1
Deionized water	175 mL	2 x 100 mL graduated cylinders	0.875

Trial #1

Date/Time	Time Elapsed (hours)	Measurement (mm)	Relative Humidity of container (%)
3/25/03 11:10 AM	0.00	39.0	34
3/25/03 12:50 PM	1.67	38.5	56
3/25/03 3:17 PM	4.12	30.0	60
3/25/03 3:35 PM	4.42	9.0	63
3/25/03 3:42 PM	4.53	5.5	52
3/25/03 3:49 PM	4.65	6.0	50
3/25/03 4:01 PM	4.85	3.5	56
3/25/03 4:15 PM	5.08	0.0	50
3/25/03 4:29 PM	5.32	2.0	55
3/25/03 4:45 PM	5.58	0.0	48

APPENDIX C

Set Time—Portland Cement Mortar (Continued)

1 Portland Cement: 3 Sand Mixture

Trial #2

Date/Time	Time Elapsed (hours)	Measurement (mm)	Relative Humidity of container (%)
3/25/03 11:12 AM	0.00	40.0	34
3/25/03 12:51 PM	1.65	39.0	56
3/25/03 3:19 PM	4.12	19.0	60
3/25/03 3:37 PM	4.42	5.5	63
3/25/03 3:44 PM	4.53	6.5	52
3/25/03 3:50 PM	4.63	4.0	50
3/25/03 4:01 PM	4.82	2.5	56
3/25/03 4:16 PM	5.07	3.0	50
3/25/03 4:29 PM	5.28	1.0	55
3/25/03 4:45 PM	5.55	0.0	48

Trial #3

Date/Time	Time Elapsed (hours)	Measurement (mm)	Relative Humidity of container (%)
3/25/03 11:13 AM	0.00	38.0	34
3/25/03 12:52 PM	1.65	37.5	56
3/25/03 3:20 PM	4.12	21.0	60
3/25/03 3:38 PM	4.42	3.0	63
3/25/03 3:45 PM	4.53	5.5	52
3/25/03 3:51 PM	4.63	5.5	50
3/25/03 4:02 PM	4.82	2.0	56
3/25/03 4:16 PM	5.05	1.5	50
3/25/03 4:30 PM	5.28	0.0	55
3/25/03 4:45 PM	5.53	0.0	48

APPENDIX D—SURFACTANT DATA

Photomicrographs of Sodium Chloride Solutions Treated with Surfactants

Control Sample (NaCl), 40x magnification

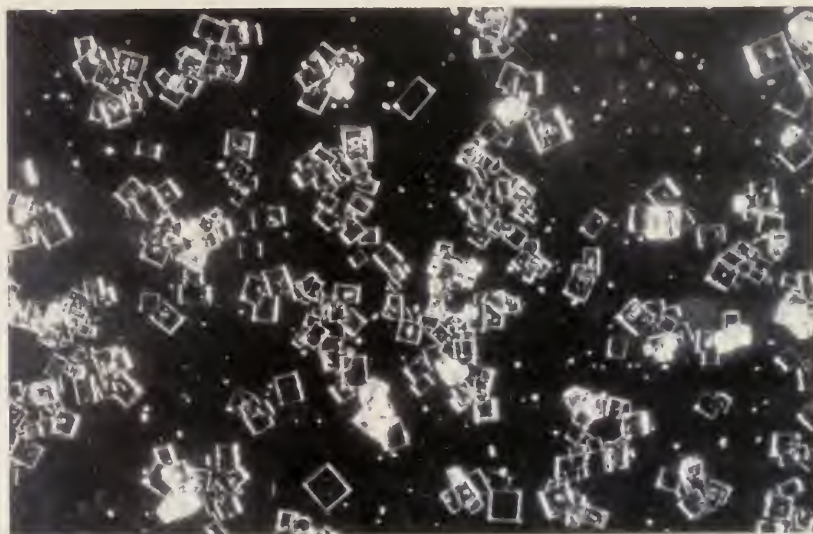

APPENDIX D

0.5% Triton (nonionic surfactant), 40x magnification



1% Triton (nonionic surfactant), 40x magnification

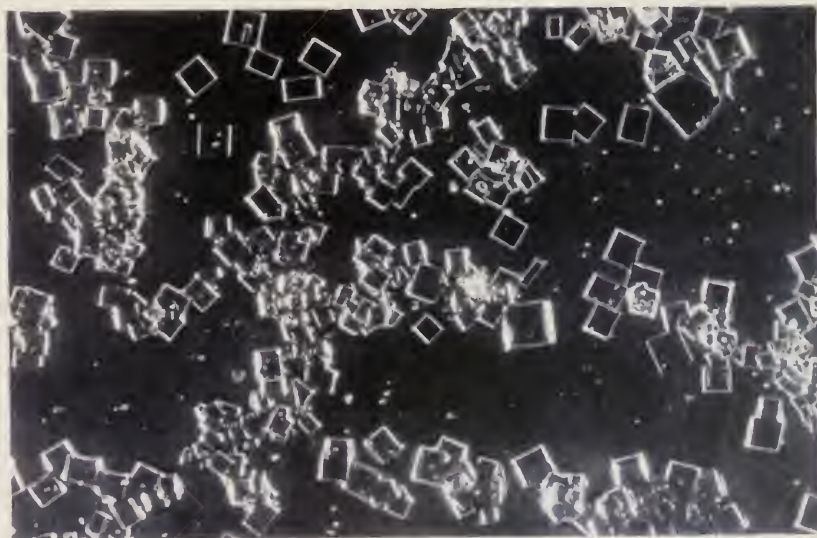

APPENDIX D

2% Triton (nonionic surfactant), 40x magnification

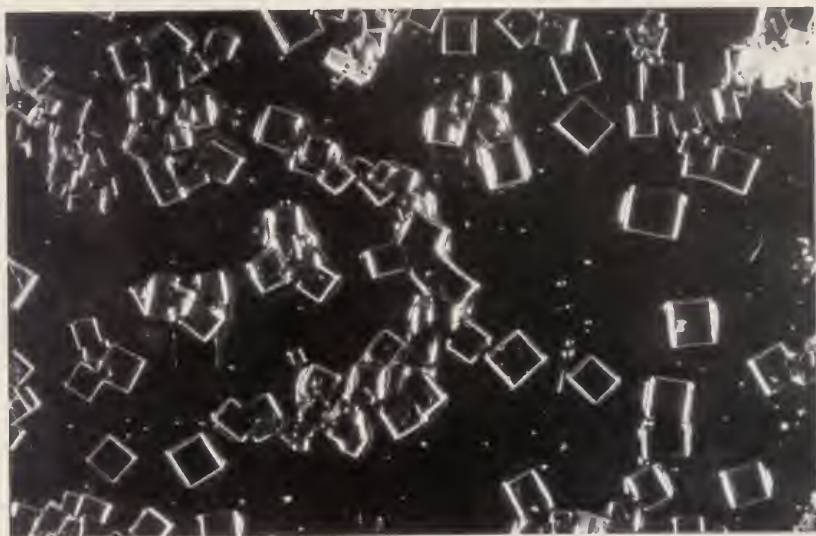

0.5% Orvus (anionic surfactant), 40x magnification



APPENDIX D

1% Orvus (anionic surfactant), 40x magnification

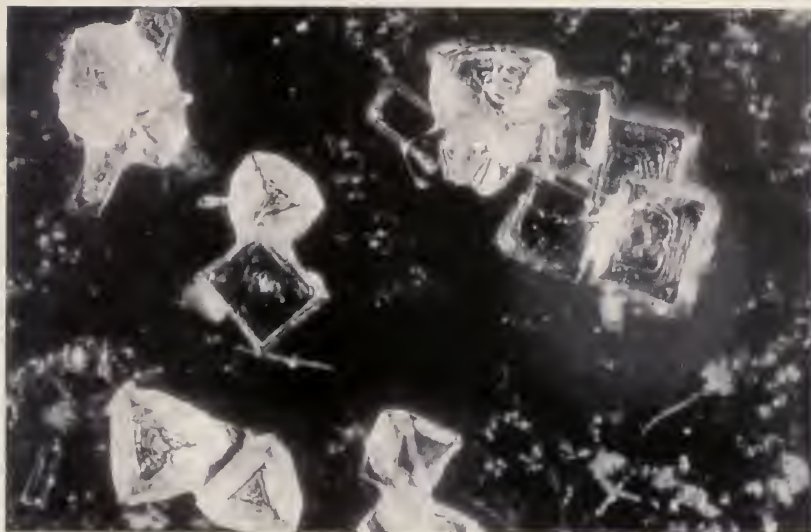

2% Orvus (anionic surfactant), 40x magnification

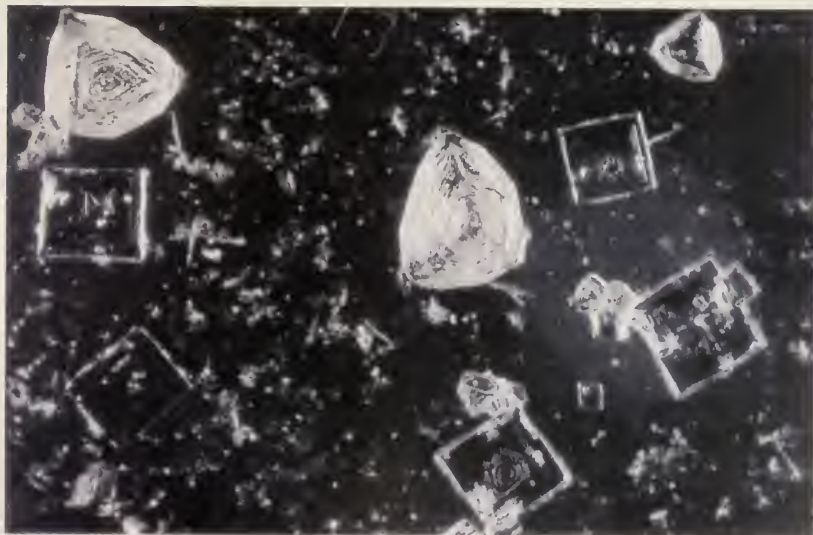

APPENDIX D

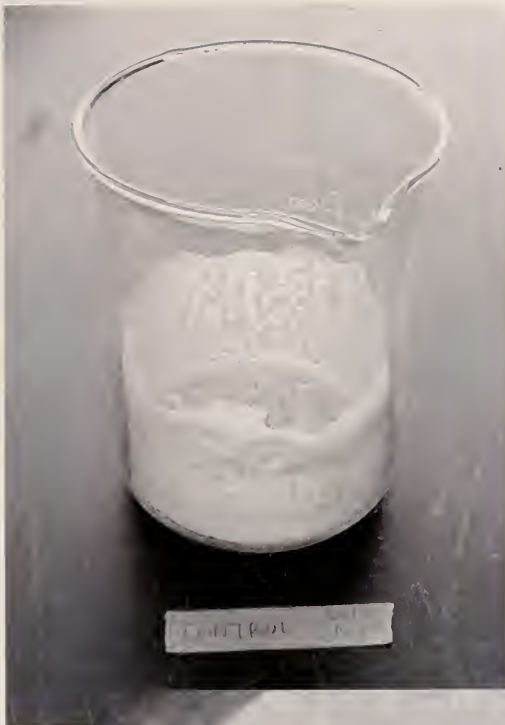

50 mL of saturated sodium chloride (NaCl) solutions were mixed in 500 mL beakers. Varying concentrations of surfactants were added to the beakers and the beakers were dried in a fume hood. The following photographs show the effect of surfactants on salt crystalization in a beaker. Note differences in salt creep due to surfactant concentration.

Control Solution (50 mL NaCl):
side view and close up of inside
of beaker



APPENDIX D

0.5% Triton (nonionic surfactant) in
50 mL NaCl solution: side view and
close up of inside of beaker

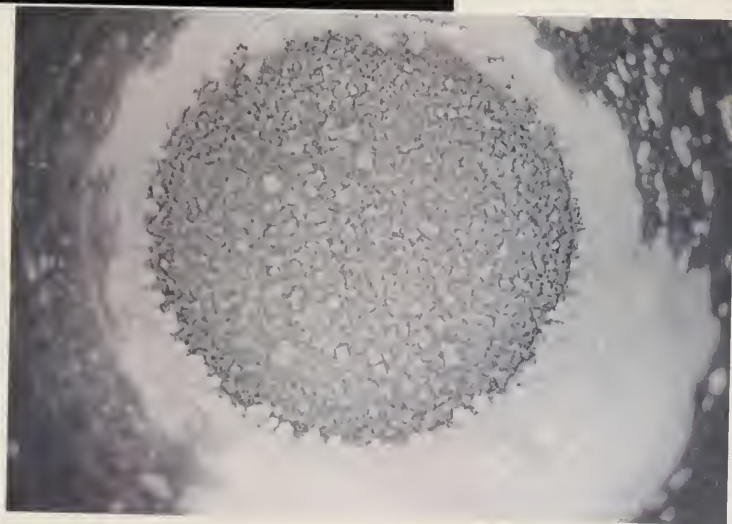

APPENDIX D

1% Triton (nonionic surfactant) in
50 mL NaCl solution: side view and
close up of inside of beaker



APPENDIX D

2% Triton (nonionic surfactant) in
50 mL NaCl solution: side view and
close up of inside of beaker

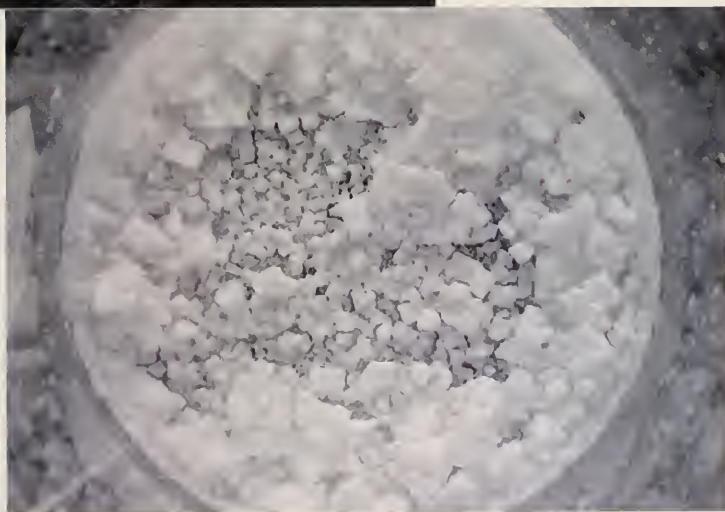
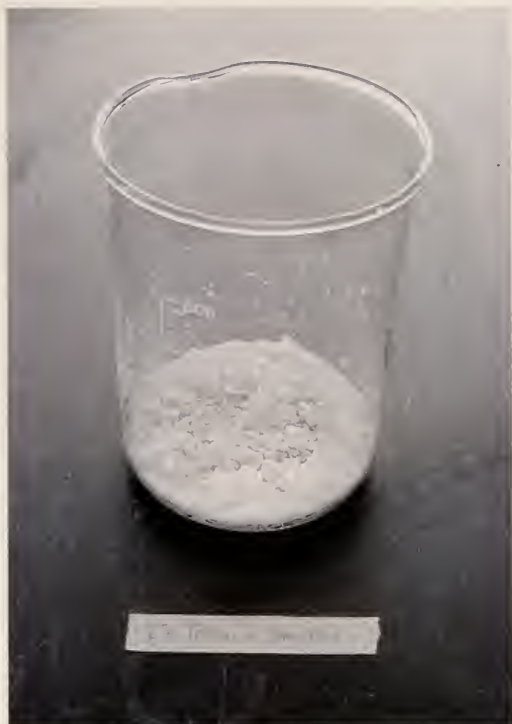

APPENDIX D

0.5% Orvus (anionic surfactant) in
50 mL NaCl solution: side view and
close up of inside of beaker



APPENDIX D

1% Orvus (anionic surfactant) in 50 mL NaCl solution: side view and close up of inside of beaker



APPENDIX D

2% Orvus (anionic surfactant) in 50 mL NaCl solution; side view and close up of inside of beaker



APPENDIX D

The beakers were placed in a storage chamber at 75% RH. The beakers were weighed daily to record their rate of moisture adsorption.

**% Weight Gain Over Time--
50 mL NaCl with BDAC Surfactant**

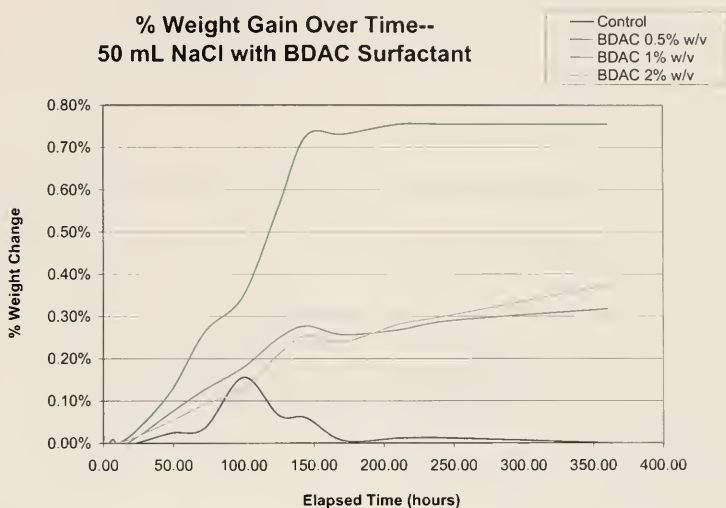

**% Weight Gain Over Time--
50 mL NaCl with Triton Surfactant**

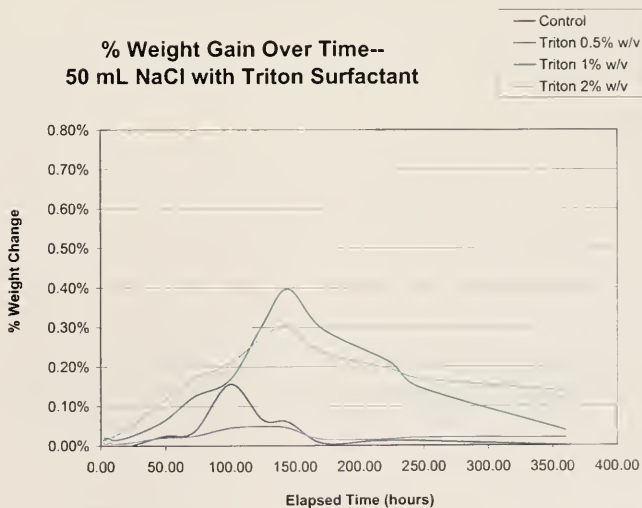

**Percent Weight Gain Over Time--
50 mL NaCl with Orvus Surfactant**

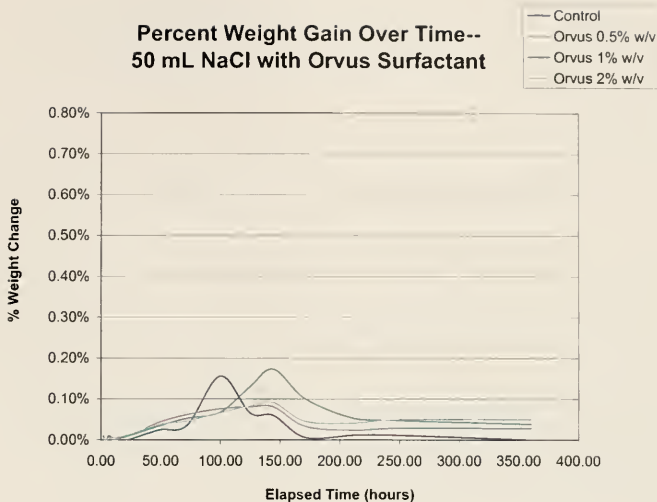

**Percent Weight Change Over Time--
50mL NaCl with 0.5% w/v surfactants**

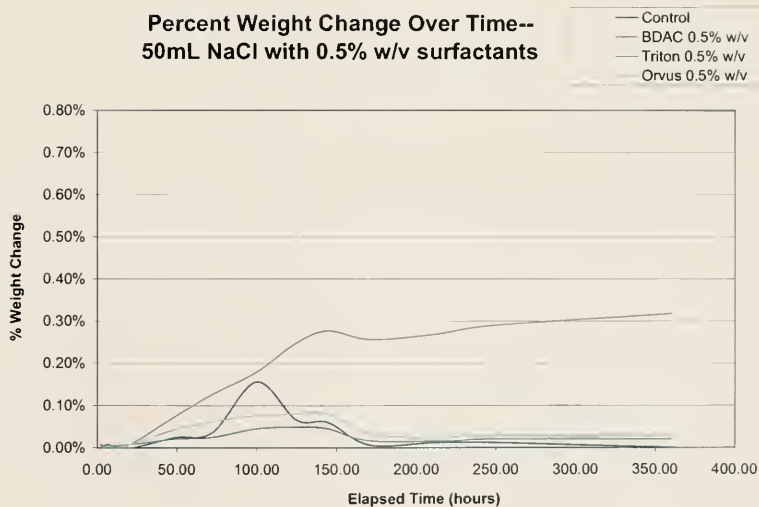

**Percent Weight Change Over Time--
50 mL NaCl with 1% w/v surfactants**

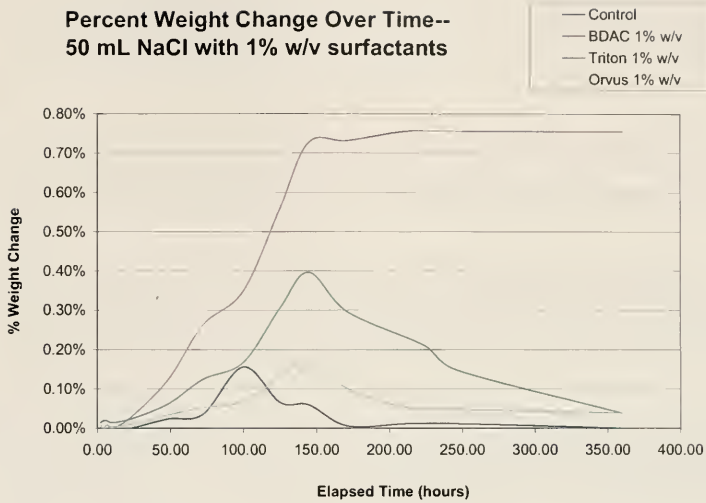

**Percent Weight Change Over Time--
50 mL NaCl with 2% w/v surfactants**

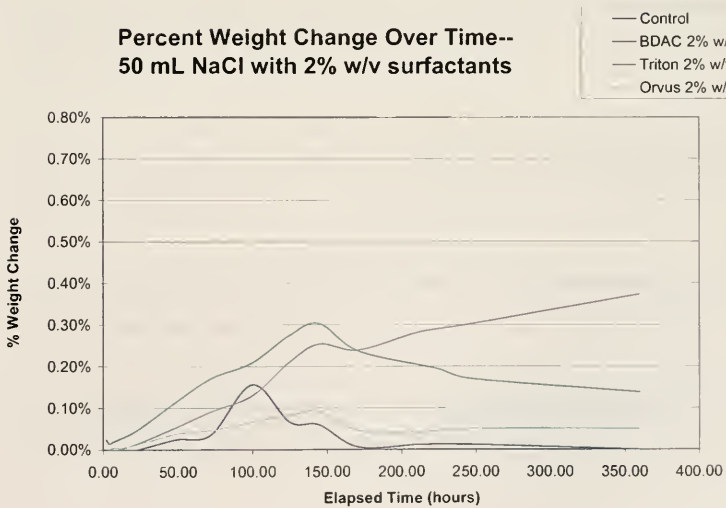

BIBLIOGRAPHY

- American Society for Testing and Materials. "C 31/C31M-96, Standard Practice for Making and Curing Concrete Test Specimens in the Field." *Annual Book of ASTM Standards*. West Conshohocken, PA: American Society for Testing and Materials, 1998.
- American Society for Testing and Materials. "C 39-96, Standard Test Method for Compressive Strength of Cylindrical Concrete Specimens." *Annual Book of ASTM Standards*. West Conshohocken, PA: American Society for Testing and Materials, 1998.
- American Society for Testing and Materials. "C 78-94, Standard Test Method for Flexural Strength of Concrete (Using Simple Beam with Third-Pointing Loading)." *Annual Book of ASTM Standards*. West Conshohocken, PA: American Society for Testing and Materials, 1998.
- American Society for Testing and Materials. "C 109/C109M-98, Standard Test Method for Compressive Strength of Hydraulic Cement Mortars (Using 2-in. or [50-mm] Cube Specimens)." *Annual Book of ASTM Standards*. West Conshohocken, PA: American Society for Testing and Materials, 1998.
- American Society for Testing and Materials. "C 110-96a, Standard Test Methods for Physical Testing of Quicklime, Hydrated Lime, and Limestone." *Annual Book of ASTM Standards*. West Conshohocken, PA: American Society for Testing and Materials, 1998.
- American Society for Testing and Materials. "C 116-90, Standard Test Method for Compressive Strength of Concrete Using Portions of Beams Broken in Flexure." *Annual Book of ASTM Standards*. West Conshohocken, PA: American Society for Testing and Materials, 1998.
- American Society for Testing and Materials. "C 143/C143M-97, Standard Test Method for Slump of Hydraulic-Cement Concrete." *Annual Book of ASTM Standards*. West Conshohocken, PA: American Society for Testing and Materials, 1998.
- American Society for Testing and Materials. "C 156-95, Standard Test Method for Water Retention by Concrete Curing Materials." *Annual Book of ASTM Standards*. West Conshohocken, PA: American Society for Testing and Materials, 1998.

- American Society for Testing and Materials. "C 157-93, Standard Test Method for Length Change of Hardened Hydraulic-Cement Mortar and Concrete." *Annual Book of ASTM Standards*. West Conshohocken, PA: American Society for Testing and Materials, 1998.
- American Society for Testing and Materials. "C 187-86 (1991) Standard Test Method for Normal Consistency of Hydraulic Cement." *Annual Book of ASTM Standards*. West Conshohocken, PA: American Society for Testing and Materials, 1998.
- American Society for Testing and Materials. "C 188-95, Standard Test Method for Density of Hydraulic Cement." *Annual Book of ASTM Standards*. West Conshohocken, PA: American Society for Testing and Materials, 1998.
- American Society for Testing and Materials. "C 191-92, Standard Test Method for Time of Setting of Hydraulic Cement by Vicat Needle." *Annual Book of ASTM Standards*. West Conshohocken, PA: American Society for Testing and Materials, 1998.
- American Society for Testing and Materials. "C 230-97, Standard Specification for Flow Table for Use in Tests of Hydraulic Cement." *Annual Book of ASTM Standards*. West Conshohocken, PA: American Society for Testing and Materials, 1998.
- American Society for Testing and Materials. "C 232-92, Standard Test Method for Bleeding of Concrete." *Annual Book of ASTM Standards*. West Conshohocken, PA: American Society for Testing and Materials, 1998.
- American Society for Testing and Materials. "C 243-95, Standard Test Method for Bleeding of Cement Pastes and Mortars." *Annual Book of ASTM Standards*. West Conshohocken, PA: American Society for Testing and Materials, 1998.
- American Society for Testing and Materials. "C 266-89 (1995), Standard Test Method for Time of Setting of Hydraulic-Cement Paste by Gillmore Needles." *Annual Book of ASTM Standards*. West Conshohocken, PA: American Society for Testing and Materials, 1998.
- American Society for Testing and Materials. "C 270-97a, Standard Specification for Mortar for Unit Masonry." *Annual Book of ASTM Standards*. West Conshohocken, PA: American Society for Testing and Materials, 1998.
- American Society for Testing and Materials. "C 305-94, Standard Practice for Mechanical Mixing of Hydraulic Cement Pastes and Mortars of Plastic Consistency." *Annual Book of ASTM Standards*. West Conshohocken, PA: American Society for Testing and Materials, 1998.

- American Society for Testing and Materials. "C 321-94, Standard Test Method for Bond Strength of Chemical-Resistant Mortars." *Annual Book of ASTM Standards*. West Conshohocken, PA: American Society for Testing and Materials, 1998.
- American Society for Testing and Materials. "C 348-97, Standard Test Method for Flexural Strength of Hydraulic-Cement Mortars." *Annual Book of ASTM Standards*. West Conshohocken, PA: American Society for Testing and Materials, 1998.
- American Society for Testing and Materials. "C 349-97, Standard Test Method for Compressive Strength of Hydraulic-Cement Mortars (Using Portions of Prisms Broken in Flexure)." *Annual Book of ASTM Standards*. West Conshohocken, PA: American Society for Testing and Materials, 1998.
- American Society for Testing and Materials. "C 403/C403M-97, Standard Test Method for Time of Setting of Concrete Mixtures by Penetration Resistance." *Annual Book of ASTM Standards*. West Conshohocken, PA: American Society for Testing and Materials, 1998.
- American Society for Testing and Materials. "C 490-96, Standard Practice for Use of Apparatus for the Determination of Length Change of Hardened Cement Paste, Mortar, and Concrete." *Annual Book of ASTM Standards*. West Conshohocken, PA: American Society for Testing and Materials, 1998.
- American Society for Testing and Materials. "C 596-96, Standard Test Method for Drying Shrinkage of Mortar Containing Hydraulic Cement." *Annual Book of ASTM Standards*. West Conshohocken, PA: American Society for Testing and Materials, 1998.
- American Society for Testing and Materials. "C 642-97, Standard Test Method for Density, Absorption, and Voids in Hardened Cement." *Annual Book of ASTM Standards*. West Conshohocken, PA: American Society for Testing and Materials, 1998.
- American Society for Testing and Materials. "C 807-89 (1995), Standard Test Method for Time of Setting of Hydraulic Cement Mortar by Modified Vicat Needle." *Annual Book of ASTM Standards*. West Conshohocken, PA: American Society for Testing and Materials, 1998.
- American Society for Testing and Materials. "C 918-97, Standard Test Method for Measuring Early-Age Compressive Strength and Projecting Later-Age Strength." *Annual Book of ASTM Standards*. West Conshohocken, PA: American Society for Testing and Materials, 1998.

- American Society for Testing and Materials. "C 952-91 (1997), Standard Test Method for Bond Strength of Mortar to Masonry Units." *Annual Book of ASTM Standards*. West Conshohocken, PA: American Society for Testing and Materials, 1998.
- American Society for Testing and Materials. "C 1072-97a, Standard Test Method for Measurement of Masonry Flexural Bond Strength." *Annual Book of ASTM Standards*. West Conshohocken, PA: American Society for Testing and Materials, 1998.
- American Society for Testing and Materials. "C 1148-92a (1997), Standard Test Method for Measuring the Drying Shrinkage of Masonry Mortar." *Annual Book of ASTM Standards*. West Conshohocken, PA: American Society for Testing and Materials, 1998.
- American Society for Testing and Materials. "E 96-95, Standard Test Methods for Water Vapor Transmission of Materials." *Annual Book of ASTM Standards*. West Conshohocken, PA: American Society for Testing and Materials, 1998.
- Armstrong, Jonathan K., Babur Z. Chowdhry, Martin J. Snowden and Stephen A. Leharne. "Effect of Sodium Chloride upon Micellization and Phase Separation Transitions in Aqueous Solutions of Triblock Copolymers: A High-Sensitivity Differential Scanning Calorimetry Study." *Langmuir* 14 (1998): 2004-2010.
- Ashurst, John and Nicola Ashurst. "Mortars, Plasters, and Renders." In *Practical Building Conservation, Vol. 3*. Hants, England: Gower Technical Press, 1989.
- Aveyard, R. "Adsorption at the Air/Liquid, Liquid/Liquid, and Solid/Liquid Interfaces." In *Surfactants*, edited by Th. F. Tadros. London: Academic Press, Inc., 1984.
- Blake, T.D. "Wetting." In *Surfactants*, edited by Th. F. Tadros. London: Academic Press, Inc., 1984.
- Bourguignon, Elsa S.O. *Study of Deterioration Mechanisms and Protective Treatments for the Egyptian Limestone of the Ayyubid City Wall of Cairo*. Master's Thesis, University of Pennsylvania, 2000.
- Callebaut, K, J. Elsen, K. van Balen and W. Viaene. "Historical and Scientific Study of Hydraulic Mortars from the Nineteenth Century." *International RILEM Workshop on Historic Mortars: Characteristics and Tests*. (Paisley, Scotland: RILEM Publications S.A.R.L., 1999): 125-132.

- Charola, A. Elena and Fernando M.A. Henriques. "Hydraulicity in Lime Mortars Revisited." *International RILEM Workshop on Historic Mortars: Characteristics and Tests*. (Paisley, Scotland: RILEM Publications S.A.R.L., 1999): 95-104.
- Charola, A. Elena and F.M.A. Henriques. "Lime Mortars: Some Considerations on Testing Standardization." In *Use of and Need for Preservation Standards in Architectural Conservation, ASTM STP 1355*, edited by L.B. Sickels-Taves. West Conshohocken, PA: American Society for Testing and Materials, 1999.
- Cotterill, Rodney. "Almost Forever, Ceramics." In *The Cambridge Guide to the Material World*. Cambridge: Cambridge University Press, 1989.
- Cowan, Henry J. and Peter R. Smith. "Gypsum, Lime and Cement." In *The Science and Technology of Building Materials*. New York: Van Nostrand Reinhold, 1988.
- Cowper, A.D. *Lime and Lime Mortars*. Shaftesbury, England: Donhead Publishing Ltd., 1998.
- Cullum, D.C. "Surfactant Types; Classification, Identification, Separation." In *Introduction to Surfactant Analysis*, edited by D.C. Cullum. London: Blackie Academic & Professional, 1994.
- Damidot, D. and A. Nonat. "Investigations of the C₃S Hydration Process during the First Hours of Hydration." In *Proceedings of the International RILEM Workshop on Hydration and Setting: Hydration and Setting of Cements*, edited by A. Nonat and J.C. Mutin. London: E & FN Spon, 1992.
- Davison, J.I. "Masonry Mortar." *Canadian Building Digest*. No. 163 (1974).
- Dossett, James W. *Composite Repair of Sandstone*. Master's Thesis, University of Pennsylvania, 1998.
- Dutt, G. Bhaskar, J. van Stam and F.C. De Schryver. "Are Aqueous Sodium Dodecyl Sulfate Micelles in the Presence of Added Salt Polydisperse? A Time-Resolved Fluorescence Quenching Study with Global Analysis." *Langmuir* 13 (1997): 1957-1963.
- Ellison, Peter T. *Hydraulic Lime Mortars*. Master's Thesis, University of Pennsylvania, 1998.
- Emley, Warren E. *Technologic Papers of the Bureau of Standards, No. 169: Measurement of Plasticity of Mortars and Plasters*. Washington, D.C.: Government Printing Office, 1920.

- European Committee for Standardization. "EN 1015-2: 1995 E, Methods of Test for Mortar for Masonry—Part 2: Bulk Sampling of Mortars and Preparation of Test Mortars." Brussels: European Committee for Standardization, 1995.
- European Committee for Standardization. "EN 1015-3: 1995 E, Methods of Test for Mortar for Masonry—Part 3: Determination of Consistency of Fresh Mortar (by Flow Table)." Brussels: European Committee for Standardization, 1995.
- European Committee for Standardization. "EN 1015-4: 1995 E, Methods of Test for Mortar for Masonry—Part 4: Determination of Consistence of Fresh Mortar (by Plunger Penetration)." Brussels: European Committee for Standardization, 1995.
- European Committee for Standardization. "EN 1015-6: 1995 E, Methods of Test for Mortar for Masonry—Part 6: Determination of Bulk Density of Fresh Mortar." Brussels: European Committee for Standardization, 1995.
- European Committee for Standardization. "EN 1015-8: 1993 E, Methods of Test for Mortar for Masonry—Part 8: Determination of Water Retentivity of Fresh Mortar." Brussels: European Committee for Standardization, 1993.
- European Committee for Standardization. "EN 1015-10: 1995 E, Methods of Test for Mortar for Masonry—Part 10: Determination of Dry Bulk Density of Hardened Mortar." Brussels: European Committee for Standardization, 1995.
- European Committee for Standardization. "EN 1015-11: 1995 E, Methods of Test for Mortar for Masonry—Part 11: Determination of Flexural and Compressive Strength of Hardening Mortar." Brussels: European Committee for Standardization, 1995.
- European Committee for Standardization. "EN 1015-12: 1993 E, Methods of Test for Mortar for Masonry—Part 12: Determination of Adhesive Strength of Hardened Rendering and Pastering Mortars on Substrates." Brussels: European Committee for Standardization, 1993.
- European Committee for Standardization. "EN 1015-13: 1993 E, Methods of Test for Mortar for Masonry—Part 13: Determination of Dimensional Stability of Hardened Mortars." Brussels: European Committee for Standardization, 1993.
- European Committee for Standardization. "EN 1015-18: 1994 E, Methods of Test for Mortar for Masonry—Part 18: Determination of Water Absorption Coefficient due to Capillary Action of Hardened Rendering Mortar." Brussels: European Committee for Standardization, 1995.

- European Committee for Standardization. "EN 1015-19: 1995, Methods of Test for Mortar for Masonry—Part 19: Determination of Water Vapour Permeability of Hardened Rendering and Plastering Mortars." Brussels: European Committee for Standardization, 1995.
- Gillmore, Q.A. *Practical Treatise on Limes, Hydraulic Cements, and Mortars*. New York: D. Van Nostrand, Publisher, 1874.
- Goodman, Mark M. *The Effects of Wood Ash Additive on the Structural Properties of Lime Plaster*. Master's Thesis, University of Pennsylvania, 1998.
- Hansen, Eric F., Alberto Tagle, Evin Erder, Susan Baron, Samuel Connell, Carlos Rodriguez-Navarro and Koenraad van Balen. "Effects of Ageing on Lime Putty." *International RILEM Workshop on Historic Mortars: Characteristics and Tests*. (Paisley, Scotland: RILEM Publications S.A.R.L., 1999): 197-206.
- Henriques, F.M.A. "Testing Methods for the Evaluation of New Mortars for Old Buildings." *Science and Technology for Cultural Heritage* 5, no. 1 (1996): 57-61.
- Henriques, Fernando M.A. and A. Elena Charola. "Comparative Study of Standard Test Procedures for Mortars." In *Proceedings of the 8th International Congress on Deterioration and Conservation of Stone*, edited by J. Riederer. Berlin: Moeller Druck und Verlag, 1996.
- Hughes, D.C. and D.B. Sugden. "The Use of Brick Dust as a Pozzolanic Addition to Hydraulic Lime Mortars." *International RILEM Workshop on Historic Mortars: Characteristics and Tests*. (Paisley, Scotland: RILEM Publications S.A.R.L., 1999): 351-359.
- International Union of Testing and Research Laboratories for Materials and Structures. "Test No. II.6, Water Absorption Coefficient (Capillarity)."
- International Union of Testing and Research Laboratories for Materials and Structures. "MR-6 Tendency of Water to Separate from Mortars (Bleeding)."
- Lindman, B. "Structural Aspects of Surfactant Micellar Systems." In *Surfactants*, edited by Th. F. Tadros. London: Academic Press, Inc., 1984.
- Livesey, Paul. "Succeeding with Hydraulic Lime Mortars." *Journal of Architectural Conservation* 2 (July 2002): 23-37.
- Mansfield, W.W. "Influence of Monolayers on the Natural Rate of Evaporation of Water." *Nature* 175 (February 25, 1955): 247-249.

- McCormack, Melissa. *Conservation Studies for the Ayyubid City Wall, Cairo*. Master's Thesis, University of Pennsylvania, 2001.
- McKee, Harley J. *Introduction to Early American Masonry*. Washington, D.C.: National Trust for Historic Preservation, 1973.
- Moon, Judi J. *A Study to Improve Desalination Methodologies for the Ayyubid City Wall, Cairo*. Master's Thesis, University of Pennsylvania, 2002.
- Mortars, Cements and Grouts Used in the Conservation of Historic Buildings: Symposium 3-6.11.1981 Rome*. Rome: ICCROM, 1982.
- NORMAL 11/85. Capillary Water Absorption and Capillary Absorption Coefficient. Original in Italian, draft translation by A.E. Charola. Photocopy.
- NORMAL 21/85. Water Vapour Permeability. Original in Italian, draft translation by A.E. Charola. Photocopy.
- Ottewill, R.H. "Introduction." In *Surfactants*, edited by Th. F. Tadros. London: Academic Press, Inc., 1984.
- Polak, W. and K. Sangwal. "Study of the Geometry of KCl Clusters Nucleating From Vapour and in Aqueous Solutions." *Journal of Crystal Growth* 203 (1999): 434-442.
- Porter, M.R. *Handbook of Surfactants, 2nd Ed.* London: Blackie Academic & Professional, 1994.
- Pühringer, Josef and L. Engström. "Unconventional Methods for the Prevention of Salt Damage." *The 5th International Congress on Deterioration and Conservation of Stone* (Lausanne: Presses Polytechniques Romandes, 1985): 241-250.
- Pühringer, Josef. "Building Moisture Physics—Salts and Surfactants." *Nordic Symposium on Building Physics* (Lund, Sweden: Lunds Universitet, 1987): 470-477.
- Pühringer, Josef and Johannes Weber. "A Model for Salt Extraction—Some Principles." *Preprints of the 9th Triennial Meeting of the ICOM Committee for Conservation* (Los Angeles: ICOM Committee for Conservation, 1990): 355-360.
- Rodriguez-Navarro, Carols, Eric Doehne, and Eduardo Sebastian. "Influencing Crystallization Damage in Porous Materials Through the Use of Surfactants: Experimental Results Using Sodium Dodecyl Sulfate and Cetyldimethylbenzylamm onium Chloride." *Langmuir* 16 (2000): 947-954.

- Rodriguez-Navarro, Carlos, Lucia Linares Fernandez and Eduardo Sebastian. "New Developments for Preventing Salt Damage to Porous Ornamental Materials Through the Use of Crystallization Inhibitors." *"SALTeXPert" Workshop: Salt Damage and Desalination*. Prague: ARCCCHIP and the Getty Conservation Institute, 2002 (to be posted: <http://www.arcchip.cz/#workshops>).
- Rossi-Doria, P. Roti. "Mortars for Restoration: Basic Requirements and Quality Control." *Materials and Structures* 19, no. 114 (1986): 445-448.
- Selwitz, Charles and Eric Doehne. "The Evaluation of Crystallization Modifiers for Controlling Salt Damage to Limestone." *Journal of Cultural Heritage* 3, no. 3 (2002): 205-216.
- Southall, Anna. "Detergents Soaps Surfactants." *Dirt and Pictures Separated*. (London: The United Kingdom Institute for Conservation, 1990): 29-34.
- Stewart, John, Richard Glover, John Houston, Nigel Seeley and Trevor Proudfoot, "Field and Laboratory Assessment of Lime-Based Mortars." *Journal of Architectural Conservation* 1 (March 2001): 7-41.
- Taylor, H.F.W. *Cement Chemistry*. London: Academic Press, 1990.
- Teutonico, Jeanne Marie, Iain McCaig, Colin Burns, and John Ashurst. "The Smeaton Project: Factors Affecting the Properties of Lime-Based Mortars." *APT Bulletin* 25, nos. 3-4 (1994): 34-49.
- Teutonico, Jeanne Marie, Geoff Ashall, Elizabeth Garrod and Tim Yates. "A Comparative Study of Hydraulic Lime-Based Mortars." *International RILEM Workshop on Historic Mortars: Characteristics and Tests*. (Paisley, Scotland: RILEM Publications S.A.R.L., 1999): 339-349.
- Thompson, Margaret L. "Plasticity, Water Retention, Soundness and Sand Carrying Capacity: What a Mortar Needs." *International RILEM Workshop on Historic Mortars: Characteristics and Tests*. (Paisley, Scotland: RILEM Publications S.A.R.L., 1999): 163-171.
- Ueno, Yasuo. "Studies of Salt-Solution Aerosols—XIII: Effect of Surface-Active Substances on the Stability of Aqueous Salt Solution Aerosols." *Atmospheric Environment* 10 (1976): 409-413.
- Van Balen, K. and D. Van Gemert. "Modelling Lime Mortar Carbonation." *Materials and Structures* 27 (1994): 393-398.

INDEX

- A**
- Abu El Nomros.....5, 74
- Adhesion.....34, 58, 97, 102, 104, 125
- adhesive strength.....(see bond strength)
- Aga Khan Trust for Culture.....1, 2
- al-Azhar Park project.....2, 3
- al-Darb al-Ahmar district.....1
- alkali earth hydroxides.....58, 83
- alkali hydroxides.....58, 83
- American Society for the Testing
of Materials (ASTM).....5
- amphipathic compounds.....106
- amphoteric.....107, 108, 110
- anionic surfactants
6, 108, 109, 114, 115, 121, 122
- anti-corrosive treatments106
- Architectural Conservation
Laboratory (ACL)...43, 48, 75, 77
- associating colloids.....106
- ASTM C 78-94.....104
- ASTM C 109.....21
- ASTM C 110-96a.....31, 32
- ASTM C 143/C143M-97.....8, 9, 12
- ASTM C 156-95.....15
- ASTM C 157.....37
- ASTM C 187-86 (1991).....8, 9, 13, 24
- ASTM C 191-92.....
7, 23, 24, 25, 26, 27, 29, 30, 31, 63, 88
- ASTM C 192.....19
- ASTM C 230.....21
- ASTM C 232-92.....17, 18, 19, 20
- ASTM C 243-95.....17, 18, 20
- ASTM C 266-89 (1995).....23, 26
- ASTM C 305.....13, 27, 29, 36, 44
- ASTM C 349-97.....104
- ASTM C 403/C 403M-97.....23, 28
- ASTM C 469-94.....104
- ASTM C 511.....27, 30
- ASTM C 596-96.....34, 35, 36, 37
- ASTM C 807 - 89 (1995).....29
- ASTM C 908-89 (1995).....23
- ASTM C 952-91.....104
- ASTM C 1148-92a (1997).....
7, 34, 35, 36, 39, 67
- ASTM E 96-95.....104
- ASTM Practice C.....172 28
- Ayyubid wall.....
1, 2, 3, 4, 5, 6, 17, 42, 43, 75, 96, 97, 98,
102, 104, 105, 123, 124, 125
- B**
- Bab al-Mahruq gate.....2
- Bactericides.....109
- Bani Yousef sand....4, 40, 42, 70, 71, 72
- BDAC.....6, 109
- bedding mortar.....
4, 22, 40, 51, 52, 59, 65, 67, 71, 81,
83, 85, 93, 94, 95, 96, 98, 99, 101, 104
- biocides.....106
- bleeding.....
5, 7, 17, 18, 19, 20, 22, 43, 45, 58, 56,
59, 60, 61, 62, 75, 76, 79, 82, 83, 84,
85, 86, 87, 94, 96, 97, 98, 99, 100,
102, 103, 104
- bleed water.....20, 28, 59, 83, 85, 94
- bond strength
5, 6, 14, 58, 83, 97, 103, 124
- Bourguignon, E.....2, 6
- brick dust
4, 5, 40, 42, 44, 64, 70, 75, 88, 95, 96,
97, 101, 103, 124
- Brown & Sharpe Dial-Cal® Dial
Calipers.....47
- bulk density.....5, 104
- C**
- calcite.....121, 123, 124, 125
- calcium carbonate.....6, 43, 44, 105
- calcium hydroxide.....43, 64, 88
- calcium silicate.....43, 44, 58, 83, 95
- calcium disilicate.....64, 88, 89, 95

calcium trisilicate.....64, 89, 95
 capillary water absorption.....104
 Capitol Cement.....44, 75
 carbonate.....98
 carbonation.....14, 15, 97, 103, 123
 carboxylate.....109
 cationic surfactants.....6, 108, 109
 Centre Scientifique et Technique
 du Batiment (CSTB).....25
 chloride ions.....110, 121
 colloidal electrolytes.....106
 Comité de Conservation des
 Monuments de l'Art Arabe.....2, 3, 4
 compressive strength.....
 25, 67, 97, 98, 104

 consistency.....
 5, 7, 8, 9, 10, 11, 12, 13, 14, 16, 18,
 21, 23, 30, 43, 45, 47, 48, 49, 50,
 51, 52, 54, 55, 58, 64, 75, 76, 77, 78,
 79, 80, 81, 83, 89, 93, 98
 contact angle.....107, 111
 cotton gauze.....16, 38, 52, 53
 creep.....122
 critical micelle concentration (cmc).....
 107, 108, 110, 111, 113
 cumulative bleeding rate.....
 60, 61, 62, 84, 86, 87, 95, 100, 101
 curing conditions.....14, 88

D
 Darassa Hills.....1, 2, 3, 6, 105
 defoamers.....106
 deionized water.....
 44, 48, 49, 50, 51, 52, 76, 77, 79
 desalination.....6, 106, 114, 115, 124
 detergents.....106, 108, 109, 110
 dispersing agents.....106, 110
 Dossett, J.45

dry ingredient mixture.....
 70, 74, 76, 77, 84, 86, 87, 90, 91, 92

E

efflorescence.....105, 112
 Egyptian limestone.....
 1, 2, 3, 5, 6, 17, 97, 104, 105, 114,
 116, 123, 125
 elasticity.....104
 electrolyte.....110, 121
 El Katameia masonry sand.....
 4, 70, 72, 73, 74
 Emley, Warren E.33
 Emley Plasticimeter7, 31, 32, 33
 emulsifiers109, 110
 EN 1015-216
 EN 1015-3: 1995 E7, 8, 9, 14, 45, 76
 EN 1015-4: 1995 E8, 9, 11
 EN 1015-8: 1993 E...7, 15, 17, 33, 52, 80
 EN 1015-10a: 1995 E104
 EN 1015-13: 1993 E34, 35, 37
 ettringite58, 64, 83, 88
 European Committee for
 Standardization (CEN)5

F

filter paper16, 17, 38, 52, 53, 70, 71
 finish pointing mortar.....
 4, 70, 71, 72, 73, 74, 75, 77, 78, 79,
 80, 81, 82, 83, 85, 89, 90, 91, 97, 98,
 99, 100, 101, 102, 103, 104
 flexural strength25, 97, 67, 104
 flow measurement.....
 48, 49, 50, 51, 77, 78, 79
 flow table9, 10, 14, 21, 45, 47, 51
 fluorocarbons106

- G**
- George F. Kempf Building
 Materials Supply Company.....41, 71
 George Schofield Company.....73
 Gillmore apparatus.....23, 26, 27
 gypsum.....4, 6, 105
- H**
- Halite.....6, 105
 Hansen, E., et al.43
 hydrocarbon106, 107, 108, 109, 110
 hydrophilic106, 107, 109, 110
 hydrophobic106, 107, 108
 Hobart C-100 mixer44
- I**
- International Union of Testing and
 Research Laboratories for
 Materials and Structures (RILEM)...
5, 18
- J**
- JEOL JSM-6300 FV
 scanning microscope.....116
- K**
- Kempf yellow bar sand.....70, 71, 72
 Kempf yellow concrete sand...40, 41, 71
- L**
- length comparator.....35, 36, 37, 38, 69
- lime putty.....
 3, 4, 5, 25, 31, 34, 36, 37, 40, 43, 44,
 45, 47, 48, 49, 54, 55, 58, 59, 60, 63,
 64, 65, 66, 67, 68, 70, 75, 76, 77, 78,
 80, 81, 82, 83, 84, 88, 89, 90, 93, 94,
 95, 96, 97, 98, 99, 101, 102, 103
 lime water.....44, 47, 49, 76, 77, 78
 liquid displacement bleeding
 apparatus.....20, 21
 lubricants.....106, 109
- M**
- McCormack, M.6
 McKee, H.15
 mechanical tests97, 98, 104
 micelle107, 108, 110, 130
 mix water
 10, 17, 45, 64, 76, 77, 78, 79, 80, 83,
 89, 93, 99
 modulus of elasticity25
 monolayer107, 111
 Moon, J.6, 114, 116
 mortar proportions4, 40, 70
- N**
- natural hydraulic lime.....
 3, 5, 40, 43, 44, 48, 49, 50, 51, 54,
 55, 56, 59, 61, 63, 64, 65, 66, 70,
 75, 76, 77, 79, 80, 81, 82, 85, 86, 88,
 90, 91, 93, 94, 95, 96, 97, 98, 99,
 100, 101, 102, 103
 nitrogen109
 nonionic surfactants.....
 6, 107, 108, 110, 111, 113, 114,
 115, 121, 123, 124
 NORMAL 21/85104
 NORMAL 29/88104
 NORMAL 7/81104
 NORMAL standards5
 nucleation inhibitor114

O

Orvus WA paste.....
6, 109, 114, 115, 116, 121, 122, 124

P

paraffin chain salts.....106
phosphate109
phosphorous109
plasticity5, 7, 31, 33, 43, 93
porosity58, 82, 113
Portland cement
2, 3, 4, 5, 14, 34, 40, 43, 44, 48, 51,
52, 54, 56, 58, 59, 62, 63, 64, 65, 67,
70, 75, 76, 77, 79, 80, 82, 83, 85, 87,
88, 89, 91, 92, 93, 94, 95, 96, 97, 98,
99, 100, 101, 102, 103
portlandite.....34
poulticed/poulticing.....
6, 114, 115, 116, 121
pozzolanic component.....
5, 6, 42, 64, 75, 88, 95, 97, 101,
103, 123
Proctor & Gamble.....114
Pühringer.....113, 121, 123

R

relative humidity.....
22, 24, 25, 31, 33, 35, 36, 37, 38, 39,
45, 47, 48, 58, 63, 67, 69, 76, 77, 79,
88, 97, 104, 105
release agents106
RILEM MR-6...7, 17, 18, 20, 22, 56, 82
Riverton Corporation43, 75
Riverton natural hydraulic lime.....
(see natural hydraulic lime)
Roby, Thomas.....4
Rodriguez-Navarro, C., et al.114

S

Salah ad-Din.....1
salt(s)
3, 6, 17, 58, 83, 105, 109, 110, 112,
113, 114, 116, 121, 122, 123, 125
salt resistance.....5, 104
scanning electron micrographs116
scanning electron microscopy6
Schofield yellow mason sand...70, 73, 74
set time
5, 7, 22, 25, 26, 28, 29, 30, 43, 45,
63, 64, 65, 66, 67, 75, 76, 79, 88, 89,
90, 91, 92, 94, 95, 96, 97, 98, 101,
102, 103
shrinkage.....
5, 7, 15, 33, 34, 35, 36, 37, 39, 45,
67, 68, 69, 76, 104
slump (see consistency)
sodium calcium silicate.....44
sodium chloride.....6, 114, 116, 122, 123
softening agents.....106
subflorescences.....105
sulfur.....109
sulphate.....109
sulphonate.....109
surface active agent (see surfactant)
surface tension.....107, 111, 112, 113
surfactant.....
3, 6, 105, 106, 107, 108, 109, 110,
111, 112, 113, 114, 115, 116, 122,
123, 124, 125
surfactant concentration.....
107, 108, 112, 113, 122

T

temperature
22, 24, 28, 33, 35, 36, 37, 38, 42,
45, 47, 48, 58, 63, 69, 77, 79, 88,
97, 105, 107, 110
tensides.....105
tensio-active agents.....105

Triton XL-80N.....
6, 110, 114, 115, 116, 122, 123, 124

U

Ueno, Y.113
Union Carbide Corp.114

V

Van Balen, K.97
Van Gemert, D.97
vapor pressure113, 114, 123
Vicat apparatus
9, 13, 14, 23, 24, 29, 30, 63
Vicat mold.....13, 24, 32, 47, 63
viscosity121

W

water absorption5, 104
water content
17, 28, 47, 49, 53, 54, 56, 58, 76, 81,
82, 93, 99
water retention
5, 7, 14, 15, 16, 17, 19, 43, 45, 52,
54, 55, 56, 75, 76, 79, 80, 81, 82, 93,
96, 98, 99, 101, 102, 103, 104
water vapor permeability.....5, 104
wetting.....106, 107, 110, 111, 112, 113
wood ash.....
4, 5, 19, 70, 74, 75, 81, 101, 102,
103, 124
workability
5, 31, 33, 34, 43, 45, 48, 52, 69, 76,
78, 80

Anne & Jerome Fisher
FINE ARTS LIBRARY
University of Pennsylvania

Please return this book as soon as you have finished with it. It must be returned by the latest date stamped below.

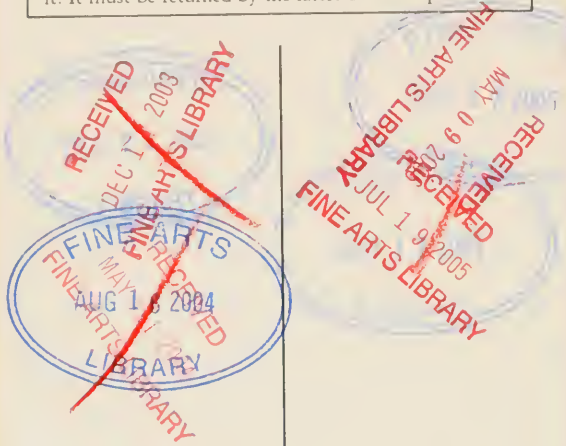



N/1198/03697/0023X

