



University of Pennsylvania Working Papers in Linguistics

Volume 18

Issue 1 *Proceedings of the 35th Annual Penn
Linguistics Colloquium*

Article 16

5-1-2012

An Asymmetric Theory of Korean Ditransitives: Evidence from Idioms

Lan Kim

University of Delaware, lank@udel.edu

This paper is posted at ScholarlyCommons. <http://repository.upenn.edu/pwpl/vol18/iss1/16>

For more information, please contact libraryrepository@pobox.upenn.edu.

An Asymmetric Theory of Korean Ditransitives: Evidence from Idioms

Abstract

This paper argues that the [Dat-Acc] and the [Acc-Acc] orders in Korean are the representations of the postpositional dative construction and the double object construction and that their syntactic structures are asymmetric. I apply the same syntactic diagnostics (nominalization and idioms) developed for English by Bruening (2010) to the data in Korean, and discuss in a greater detail that the asymmetric properties of nominalization and idioms call for Bruening's (2010) asymmetric analysis.

- (3) a. The editor sent the article to Philadelphia. Pre-DC
 b. ?? The editor sent Philadelphia the article. DOC
- (4) a. *Swu-ka seulsi-ey ton-ul cwu-ess-ta.* [DAT-ACC]
 Sue-NOM Seoul.city-DAT money-ACC give-PST-DEC
 ‘Sue gave the money to Seoul city.’
- b. ??*Swu-ka seulsi-lul ton-ul cwu-ess-ta.* [ACC-ACC]
 Sue-NOM Seoul.city-ACC money-ACC give-PST-DEC
 ‘Sue gave Seoul city the money.’

In English, in (3b) the Goal in the DOC should be animate; the appropriate reading arises only when the Goal ‘Philadelphia’ refers to a group of people or an organization. In contrast, the corresponding argument in the Pre-DC does not have to be animate, as shown in (3a). Likewise, in Korean, the first accusative argument in the [Acc-Acc] order is sensitive to the animacy constraint. That is, (4b) is possible only under the reading that *seulsi* ‘Seoul city’ refers to an animate entity such as a certain group of people, while the corresponding argument in (4a) needs not have the animacy restriction.

Second, there is a different semantic entailment between the [Dat-Acc] and the [Acc-Acc] orders, similar to the case in English (Oehrle 1976, Larson 1988).

- (5) a. John taught French to the students. Pre-DC
 b. John taught the students French. DOC

In English, the DOC in (5b), compared to the Pre-DC in (5a), has a much stronger implication that the students possess the knowledge of French. The same is also found in the corresponding data in Korean.

- (6) a. *Swu-ka haksayngtul-eykey hankwuke-lul kaluchi-ess-ta.* [DAT-ACC]
 Sue-NOM students-DAT Korean-ACC teach-PST-DEC
 ‘Sue taught Korean to the students.’
- b. *Swu-ka haksayngtul-ul hankwuke-lul kaluchi-ess-ta.* [ACC-ACC]
 Sue-NOM students-ACC Korean-ACC teach-PST-DEC
 ‘Sue taught the students Korean.’

In (6b), the [Acc-Acc] order carries the implication that the students indeed acquired some knowledge of the Korean language, while this implication is relatively weaker in the [Dat-Acc] order in (6a).

Therefore, these facts follow if the [Dat-Acc] order corresponds to the Post-DC and the [Acc-Acc] order is a representation of the DOC.

3 Two Types of Analysis in the Literature

Provided that the [Dat-Acc] order is treated as the Post-DC and the [Acc-Dat] order as the DOC, I now investigate how these two types of ditransitive constructions are mapped onto a syntactic representation. In order to do so, I first evaluate two approaches proposed in the literature: Harley’s (1997, 2002) symmetric theory and Bruening’s (2010) asymmetric theory.

3.1 Harley’s Symmetric Theory

Harley’s (2002) small clause theory treats both the Pre(or Post)-DC and the DOC as involving a PP small clause. Following Bruening’s (2010) terminology, I refer to Harley’s approach as a symmetric theory because it posits a symmetric structure for each frame. Consider (2), repeated in (7), and their symmetric structures in (8).

- (7) a. *Thomi-ka Hana-eykey aiphas-ul cwu-ess-ta.* [DAT-ACC]
 Tommy-NOM Hana-DAT iPod-ACC give-PST-DEC
 ‘Tommy gave an iPod to Hana.’
 b. *Thomi-ka Hana-lul aiphas-ul cwu-ess-ta.* [ACC-ACC]
 Tommy-NOM Hana-ACC iPod-ACC give-PST-DEC
 ‘Tommy gave Hana an iPod.’

(8) Symmetric Structure in Korean

a. Post-DC

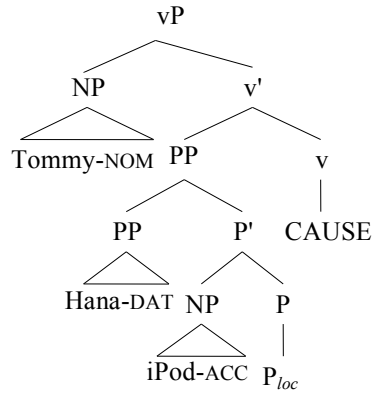

b. DOC

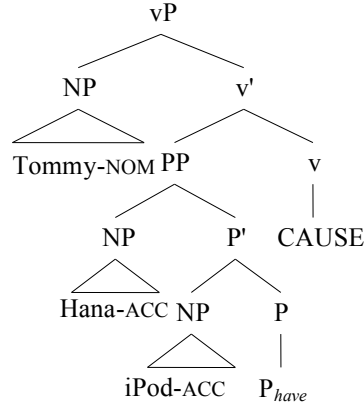

‘Tommy CAUSED an iPod to GO TO Hana.’ ‘Tommy CAUSED Hana to HAVE an iPod.’

On Harley’s symmetric theory, the Post-DC in (8a) has a locative structure headed by P_{loc} and the DOC in (8b) has a possessive structure headed by P_{have} . Ditransitive verbs are thus a combination of $[v_{cause} + P_{loc}]$ and $[v_{cause} + P_{have}]$ in the Post-DC and the DOC, respectively. This means that (7a) can be construed as ‘Tommy CAUSED an iPod to GO TO Hana’ and (7b) as ‘Tommy CAUSED Hana to HAVE an iPod’.

Harley’s account makes a convincing case for the meaning difference between the two frames, and has been extended by a number of works in other languages (Bleam 2003 on Spanish, Rimrott 2007 on German, among others). For example, Jung and Miyagawa (2004) argue that the DOC in Korean is a projection of a postpositional possessive structure like (8b).

In this paper, I also make an assumption that there is slightly different semantics between the Post-DC and the DOC as discussed in Section 2. However, I argue that positing this still does not tell us what the correct structure is for each construction. As detailed in Section 4, I will show that a Harley-type symmetric theory turns out to be inadequate to correctly account for the ditransitives in Korean.

3.2 Bruening’s (2010) Asymmetric Theory

Alternatively, I propose an asymmetric theory following Bruening’s (2010, building on ideas in Marantz 1993) proposal to the ditransitives in English, as illustrated in (9).

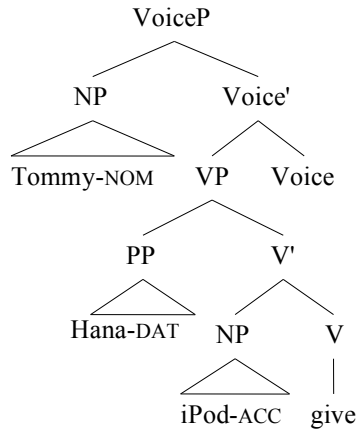
(9) Asymmetric Structure in Korean
a. Post-DC

b. DOC

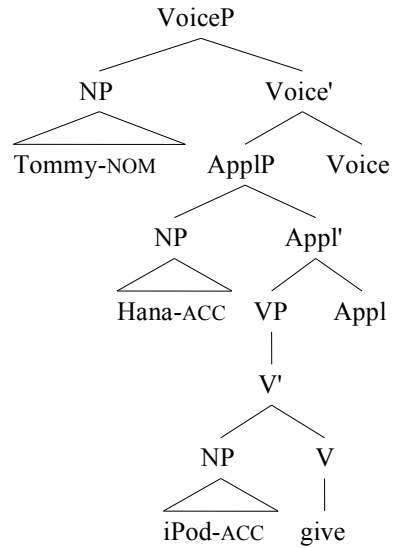

On the asymmetric account, the dative PP (the Goal) and the accusative NP (the Theme) in the Post-DC are the arguments of the ditransitive verb within the VP, as illustrated in (9a). In contrast, in the DOC, the first accusative NP is introduced by an applicative head, and the second accusative NP is the argument of the ditransitive verb, as shown in (9b). In what follows, I will discuss in a greater detail that the asymmetric theory turns out to be correct.

4 Supporting Evidence

In this section, I provide two sets of evidence from nominalization and ditransitive idioms in support of the asymmetric theory. I apply the same syntactic diagnostics developed for English by Bruening (2010) to the data in Korean, and demonstrate that Bruening's (2010) asymmetric theory is on the right track, as it can quite straightforwardly explain the asymmetric properties of nominalization and idioms between the Post-DC and the DOC in Korean. Furthermore, it will be shown that Harley's symmetric theory is empirically inadequate in handling these asymmetric properties.

4.1 Nominalization

The ditransitive constructions in Korean reveal the nominalization asymmetry between the Post-DC and the DOC: the *-(u)m* nominalization is allowed in the Post-DC but not in the DOC. Note that in the *-(u)m* nominalization, the accusative argument must bear only the postnominal genitive case marking *-uy*, whereas the dative argument must maintain its marker, and the entire PP must bear the genitive case marking. The nominalizer *-(u)m* 'the act or fact of being/doing' attaches to the base of the verb (Sohn 2001).

- (10) a. *Thim-i Swu-eykey mapep-ul kaluchi-ess-ta.*
Tim-NOM Sue-DAT magic-ACC teach-PST-DEC
'Tim taught magic to Sue.'
- b. *Swu-eykey-uy mapep-uy kaluchi-m.*
Sue-DAT-GEN magic-GEN teach-NM
'The teaching of magic to Sue (by someone)'
- (11) a. *Thim-i Swu-lul mapep-ul kaluchi-ess-ta.*
Tim-NOM Sue-ACC magic-ACC teach-PST-DEC
'Tim taught Sue magic.'

- (11) b. **Swu-uy mapep-uy kaluchi-m.*
 Sue-GEN magic-GEN teach-NM
 ‘Sue’s teaching of magic (by someone)’
 Grammatical under the reading ‘teaching of magic by Sue’³

As in (10), the Post-DC permits its nominalization. For example, the nominalized form in (10b) has the meaning of ‘the teaching of magic to Sue’. In contrast, in (11), nominalization is not possible in the DOC. That is, the sentence in (11b) is ill-formed under the intended reading of ‘Sue’s teaching of magic (by someone)’. However, note that this sentence can be considered to be grammatical if the genitive-marked *Sue* is interpreted as the agent of teaching magic (like magic teacher) to someone.

Given these facts, it follows that the asymmetric distribution of nominalization receives a simple account under the asymmetric theory, as in (9), repeated as (12) below.

- (12) Asymmetric Structure in Korean
 a. Post-DC

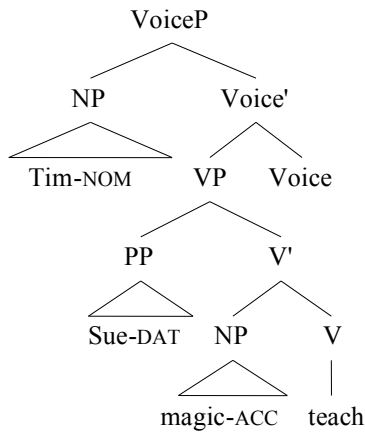

- b. DOC

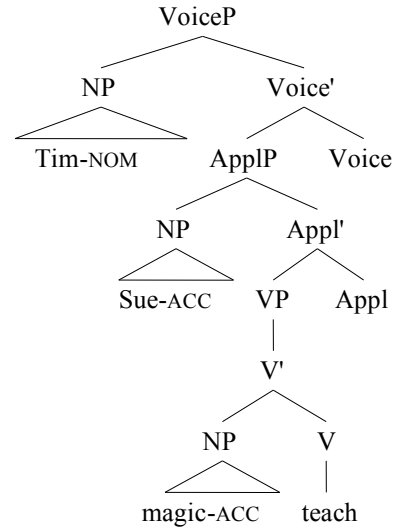

In (12b), in the DOC, the null morpheme, the head Appl, prevents additional derivation such as nominalization, as pointed out by Bruening (2010) following Pesetsky’s (1995) argument in which the affixation of null morphemes to a verbal root blocks further derivations such as nominalizations in the DOC. In contrast, in the Post-DC, this head is absent and so nothing can prevent, as illustrated in (12a).

However, this asymmetric property of the nominalization becomes a problem for the symmetric theory. On the symmetric account, either both the possible heads of PP, P_{loc} and P_{have} should block the nominalization or both should not, as criticized by Bruening’s (2010) work on ditransitives in English. That is, the nominalization should not be possible in both constructions or should be in both constructions. Thus, if the symmetric theory is to be maintained, certain modifications should be made to explain this asymmetry.

³The sentence in (11b) is grammatical under a different reading ‘teaching of magic by Sue’, where the source sentence is as follows.

- (i) *Swu-ka mapep-ul kaluchi-ess-ta.*
 Sue-NOM magic-ACC teach-PST-DEC
 ‘Sue taught magic.’
 (ii) *Swu-uy mapep-uy kaluchi-m.*
 Sue-GEN magic-GEN teach-NM
 ‘Teaching of magic by Sue’

4.2 Ditransitive Idioms

In addition to the nominalization, data from the ditransitive idioms provide support for the asymmetric theory. Specifically, it will be shown that the asymmetric approach is able to make precisely the correct predictions about possible and impossible ditransitive idioms, but that the symmetric approach is not capable of handling the data without making ad-hoc stipulations.

First, consider the table in (13) which lists logically possible idiom patterns in the ditransitives in Korean. Note that the idiomatic part is highlighted.

(13) The list of logical possibilities for the idiomatic forms in Korean ditransitives

Post-DC	Existence	DOC	Existence
Class1 [PP _{Dat} NP _{Acc} Verb]	existent	Class4 [NP _{Acc} NP _{Acc} Verb]	existent
Class2 [PP _{Dat} NP _{Acc} Verb]	existent	Class5 [NP _{Acc} NP _{Acc} Verb]	non-existent
Class3 [PP _{Dat} NP _{Acc} Verb]	existent	Class6 [NP _{Acc} NP _{Acc} Verb]	non-existent

In the Post-DC, all of the classes are extensively attested. Class 2 and Class 3 are fixed and do not alternate in the DOC. However, Class 1 may alternate: some idioms occurring with a *give*-type verb can alternate in the DOC, as in Class 4. Turning to the DOC, only Class 4 exists and this alternates with the Post-DC, as in Class 1. In addition, Class 5 and Class 6 are systematically missing. The data for each class are given in (14) through (16).

- (14) Class 1 *chimul nohta* ‘put a needle to X’
Sensayngnim-un aitul-eykey chim-ul no-ass-ta.
 teacher-TOP kids-DAT needle-ACC stick.in-PST-DEC
 Literal: ‘The teacher stuck a needle in (the arms of) the kids.’
 Idiomatic: ‘The teacher scolded/warned kids (to be quiet).’
- (15) Class 2 *ipey motelul talta* ‘put an electric motor on a mouth’
Thim-I ip-ey mote-lul tal-ass-ta.
 Tim-NOM mouth-DAT electric.motor-ACC put.on-PST-DEC
 Literal: ‘Tim put the electric motor on his mouth.’
 Idiomatic: ‘Tim spoke very fast and quickly.’
- (16) Class 3 *sonakwiey nehta* ‘put X to a webbing’
Aney-ka sonakwi-ey nampyeon-ul ne-ess-ta.
 Wife-NOM webbing-DAT husband-ACC put.in-DEC
 Literal: ‘The wife put her husband in her webbing.’
 Idiomatic: ‘The wife took possession of her husband.’

Below further shows the alternating idioms, in which the idiomatic part [NP_{Acc} Verb] in Class1 can also appear as part of an idiom in the DOC.

- (17) Alternating Class 1 and Class 4 *nukcwulul cwuta* ‘give a rope to X’ ~ ‘give X a rope’
Sensayngnim-un aitul-eykey/ul nukcwul-ul cwu-ess-ta.
 teacher-TOP kids-DAT/ACC rope-ACC give-PST-DEC
 Literal: ‘The teacher gave a loosening rope to the kids.’
 Idiomatic: ‘The teacher relaxed his supervision of the kids.’

It should be noted that in Korean there is no pure double object idiom occurring only in the double object frame; all of the alternating idioms found in Class 4 actually belong in Class 1. In addition, our survey of idioms reveals that the number of verbs allowing a double object idiom is quite limited. This is so because only a small number of ditransitive verbs (i.e., *cwu-* ‘give’ type verbs) can appear in the DOC, as noticed by Jung and Miyagawa (2004).⁴

In consequence, the idiom patterns in Korean described above are quite asymmetric: all clas-

⁴Jung and Miyagawa (2004) note that while all ditransitive verbs can occur in the Post-DC, only a small number of ditransitive verbs, such as *cwu-* ‘give’, can occur in the DOC in Korean.

ses are found in the Post-DC, while genuine double object idioms are absent.

In what follow, I show that these asymmetric distributions of the ditransitive idioms are clearly explained under Bruening's (2010) idiom-as-selection principle as illustrated in (18) in conjunction with the asymmetric theory.

(18) Bruening's (2010) Idiom-as-Selection

- a. The Principle of Idiomatic Interpretation: X and Y may be interpreted idiomatically only if X selects Y.
- b. Constraint on Idiomatic Interpretation: If X selects a lexical category Y, and X and Y are interpreted idiomatically, all of the selected arguments of Y must be interpreted idiomatically as well (Lexical categories are V, N, A, Adv).

The principle in (18) claims that idiomatic interpretations are determined by selection. For example, if the ditransitive verb 'throw' selects the dative argument 'to the wolves', they can be interpreted idiomatically.

Now consider how the asymmetric theory in combination with the selection principle accounts for the asymmetric idiom patterns.

First, by satisfying the conditions as stated in (18a), the verb and its selected arguments are interpreted idiomatically, which accounts for the existence of Classes 1, 2, 3, and 4. For example, in Class 3 [PP_{Dat} NP_{Acc} Verb], the verb selects P and P selects the dative PP, and so they receive an idiomatic interpretation.

Second, the fact that Class 4 alternates with the Post-DC follows under the current proposal. In Class 4, the verb selects the second object (Theme) and the idiom does not include the Appl head. Thus, the [NP_{Acc} Verb] combination in Class 4 can appear as part of either the DOC or the Post-DC.

At this point, one might speculate that Appl may act as some blocker in forming idioms in Korean given the existence of the alternating idioms (Class 4). I suggest that it is necessarily the case in Korean that Appl may delimit the domain of idiom formation, since there is no pure double object idiom in Korean and the only class occurring in the DOC (Class4) belongs to Class 1. It thus follows that Appl does not participate in idiom formation, as illustrated in (19).

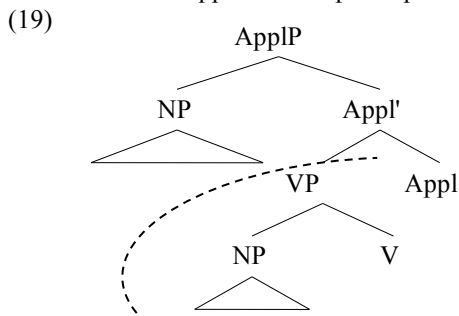

In addition, there is further evidence supporting this view. That is, if it is suggested that the Appl head is not part of an idiom in the DOC, then this head should not also be part of an idiom in other types of applicative structures, such as in benefactive constructions. This prediction is borne out, as in (20).

- (20) Benefactive idiom *pihayngkilul thaywe cwuta* [NP_{ACC} NP_{ACC} Verb]
Cikwentul-un na-eykey/lul pihayngki-lul thaywe cwu-ess-ta.
 Employees-TOP I-DAT/ACC plane-ACC ride give-PST-DEC
 Literal: 'The employees gave me a ride on a plane.'
 Idiomatic: 'The employees flattered me immensely.'

In (20), the second accusative object 'plane' and the benefactive verbs 'ride-give' are idiomatically interpreted. Similar to Class 4, this [NP_{Acc} Verb] combination can appear as part of either the DOC or the Post-DC; this is indicated by the availability of both the dative and the accusative markers, as shown in the gloss. Hence, it can be argued that Appl may delimit the domain of idiom

formation in Korean.

Returning to the idiom asymmetry, the absence of Class 5 [NP_{Acc} NP_{Acc} Verb] and Class 6 [NP_{Acc} NP_{Acc} Verb] is captured as systematically absent, because the Appl head does not participate in idiom formation.

Under the asymmetric approach, hence, the asymmetric distributions of the ditransitive idioms are explained in a quite straightforward way.

However, the symmetric theory fails in explaining possible and impossible idiom patterns. Since under Harley's approach idioms are considered as a single constituent (i.e., idiom-as-constituent theory) along the line of Larson (1988), only those which can form a constituent can be idiomatically interpreted. This line of analysis however turns out to be inadequate.

First, the existence of Class 3 [PP_{Dat} NP_{Acc} Verb] is problematic, because the combination of the dative PP and the verb should involve obligatorily the non-idiomatic accusative NP, contrary to fact.

One might wonder whether it is possible to explain the idiomatic patterns, only adopting Bruening's (2010) selection theory, while maintaining a Harley-type symmetric structure. It may at first glance seem to be possible because this would correctly predict the existence of Class 3 [PP_{Dat} NP_{Acc} Verb]; the head of PP selects the dative argument (PP) and the lexical component of the ditransitive verb.

However, such an approach turns out to be incorrect if we consider the fact that Class 6 [NP_{Acc} NP_{Acc} Verb] is systematically missing, as illustrated in (21) and (22). That is, Class 6 [NP_{Acc} NP_{Acc} Verb] should exist in a similar way that Class 3 exists; the head of PP selects the first accusative argument (NP) and the lexical component of the ditransitive verb, and so they can be idiomatically interpreted. Nevertheless, Class 6 is missing. Thus, this tells us that the symmetric structure itself is problematic.

- (21) Class 3 *sonakwiew nehta* 'put X to a webbing' Repeated from (16)
Aney-ka sonakwi-ey nampyeon-ul ne-ess-ta.
 wife-NOM webbing-DAT husband-ACC put.in-PST-DEC
 Literal: 'The wife put her husband to her webbing.'
 Idiomatic: 'The wife took possession of her husband.'
- (22) Symmetric Theory
 a. Post-DC

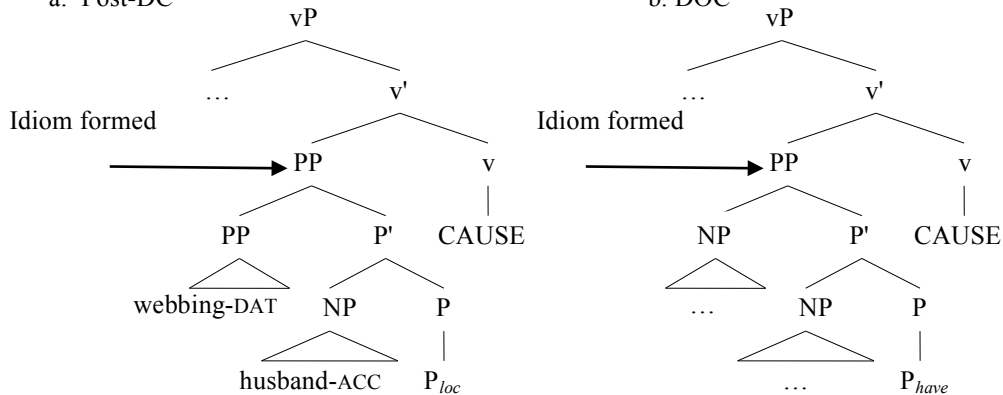

Second, under the symmetric theory, idioms are predicted not to alternate because they are fixed expressions associated with certain lexical heads P_{loc} and P_{have} . The alternating idioms, Class 4, constitute a puzzle.

Finally, the symmetric theory would not predict the absence of Class 5 [NP_{Acc} NP_{Acc} Verb], because under this analysis, the two accusative arguments can build a single constituent at the level of PP. Nonetheless, Korean uniformly lacks Class 5.

Therefore, I argue that Bruening's (2010) asymmetric theory is correct, as it can quite straightforwardly explain the asymmetric properties between the Post-DC and the DOC in Korean.

5 Conclusion

In this paper, I have shown that the [Dat-Acc] and the [Acc-Acc] orders are the representations of the Post-DC and the DOC respectively and that their syntactic structures are asymmetric. I have applied the same syntactic diagnostics (nominalization and idioms) developed for English by Bruening (2010) to the data in Korean, and it has been shown that the asymmetric approach is on the right track.

The Korean facts presented in this paper are of special interest since the internal syntactic structures of ditransitive verbs in Korean appears to be the exact mirror-image of the English ditransitive structures proposed in Bruening 2010 along the line of Marantz 1993.

References

- Bleam, Tonia. 2003. Properties of the double object construction in Spanish. In *A Romance Perspective on Language Knowledge and Use*, ed. R. Núñez-Cedeño, L. López and R. Cameron. *John Benjamins*.
- Bruening, Benjamin. 2010. Ditransitive asymmetries and a theory of idiom formation. *Linguistic Inquiry* 41:519–562.
- Harley, Heidi. 1997. If you *have*, you can *give*. In *Proceedings of the 15th West Coast Conference on Formal Linguistics*, 193–208. Stanford, Calif.: CSLI Publications. [Distributed by Cambridge University Press.]
- Harley, Heidi. 2002. Possession and the double object construction. *Linguistic Variation Yearbook* 2: 29–68.
- Hong, Kyoun-sook. 1998. Idiomatic expressions in Korean and argument structure. *Ohak Yonku/Language Research* 34:3: 547–573.
- Jackendoff, R. 1972. *Semantic interpretation in generative grammar*. Cambridge, Mass.: MIT Press.
- Jung, Yeun-jin, and Shigeru Miyagawa. 2004. Decomposing ditransitive verbs. *Proceedings of SICGG*, 101–120.
- Kim, Lan. 2008. On the ditransitive construction in Korean. *Proceedings of the Conference of the Student Organization of Linguistics in Europe XV*, 111–133.
- Larson, Richard. 1988. On the double object construction. *Linguistic Inquiry* 19: 335–391.
- Marantz, Alec. 1993. Implications of asymmetries in double object constructions. In *Theoretical Aspects of Bantu Grammar*, ed. S.A. Mchombo, 113–150. Stanford, Calif.: CSLI Publications.
- Oehrle, Richard T. 1976. The grammar of the English dative alternation. Doctoral dissertation, Massachusetts Institute of Technology.
- Pesetsky, David. 1995. *Zero syntax: experiencers and cascades*. Cambridge, Mass.: MIT Press.
- Rimrott, Anne. 2007. On double object and double complement constructions in German. *Proceedings of the 2007 annual conference of the Canadian Linguistic Association*, 1–11.
- Sohn, Ho-Min. 2001. *The Korean language*. New York: Cambridge University Press.

Department of Linguistics and Cognitive Science
 University of Delaware
 Newark, DE 19716
 lank@udel.edu