



2009

THE EARLY PHRYGIAN GATE AT GORDION, TURKEY: AN INVESTIGATION OF DRY STONE MASONRY IN SEISMIC REGIONS AND RECOMMENDATIONS FOR STABILIZATION

Meredith Arlene Keller

University of Pennsylvania, makeller@design.upenn.edu

Follow this and additional works at: http://repository.upenn.edu/hp_theses

Keller, Meredith Arlene, "THE EARLY PHRYGIAN GATE AT GORDION, TURKEY: AN INVESTIGATION OF DRY STONE MASONRY IN SEISMIC REGIONS AND RECOMMENDATIONS FOR STABILIZATION" (2009). *Theses (Historic Preservation)*. 129.

http://repository.upenn.edu/hp_theses/129

A THESIS in Historic Preservation Presented to the Faculties of the University of Pennsylvania in Partial Fulfillment of the Requirements of the Degree of MASTER OF SCIENCE IN HISTORIC PRESERVATION 2009

This paper is posted at ScholarlyCommons. http://repository.upenn.edu/hp_theses/129

For more information, please contact libraryrepository@pobox.upenn.edu.

THE EARLY PHRYGIAN GATE AT GORDION, TURKEY: AN INVESTIGATION OF DRY STONE MASONRY IN SEISMIC REGIONS AND RECOMMENDATIONS FOR STABILIZATION

Abstract

The archaeological site at Gordion, Turkey is located in a region of high seismic activity, which threatens the standing masonry structures—particularly the dry laid limestone walls—of the ancient Phrygian capital. First excavated in the 1950s, the citadel gate is composed of an ashlar limestone veneer encasing a rubble core. Although the gate has been the focus of several conservation efforts, the unreinforced masonry structure requires study and possible stabilization to mitigate and prevent further bulging or even collapse. The gate's current conditions include extensive cracking, spalls, split faces, missing chinking stones, open joints and bulges, which partially result from the complex history of the site. Constructed around 900 BC, the Early Phrygian Gate only briefly served as the main entryway to the citadel; it was then affected by fire and burial and used as a foundational support for later structures. Partial excavation has largely exposed the North and South Courts of the gate complex. However, several courses of the later building stone remain in localized areas of the gate walls, and the interior of South Court still contains the almost 3,000 year old clay construction fill. These factors have contributed to displacement of the multiple leaf system by exerting lateral force and causing compression and shear cracks. This thesis synthesizes existing knowledge of the behavior of masonry during seismic events, properties of dry stone structures and site-specific characteristics as a basis for constructing recommendations for future monitoring and stabilization efforts.

Comments

A THESIS in Historic Preservation Presented to the Faculties of the University of Pennsylvania in Partial Fulfillment of the Requirements of the Degree of MASTER OF SCIENCE IN HISTORIC PRESERVATION
2009

THE EARLY PHRYGIAN GATE AT GORDION, TURKEY
AN INVESTIGATION OF DRY STONE MASONRY IN SEISMIC REGIONS
AND RECOMMENDATIONS FOR STABILIZATION

Meredith Arlene Keller

A THESIS

in

Historic Preservation

Presented to the Faculties of the University of Pennsylvania in
Partial Fulfillment of the Requirements of the Degree of

MASTER OF SCIENCE IN HISTORIC PRESERVATION

2009

Advisor
Frank G. Matero
Professor of Architecture

Program Chair
Frank G. Matero
Professor of Architecture

ACKNOWLEDGMENTS

For offering me the opportunity to work on such a fascinating and rich archaeological site, I would like to thank Frank Matero. As a dedicated thesis advisor, he has given much encouragement and shown great interest in my work. Thanks must also be given to Michael Henry, who has provided invaluable engineering expertise. His enthusiasm for the project and weekly discussions gave me confidence to tackle the complex problems presented in this thesis.

I would also like to extend my thanks to John Hinchman for greatly improving my CAD skills and turning a piece of straw into a bale of hay. He dedicated hours of time to ensuring that the quality of the digital work reached its full potential.

A special thanks to my professors and classmates who have challenged me over these last two years. The many thesis-related conversations with Victoria Pingarron-Alvarez have been greatly valued as well. Suzanne Hyndman has also provided much appreciated assistance with numerous tasks.

Thanks to Matt for his support and many dinners when I had such little time to cook. Also, I would like to express my deepest gratitude to my parents, who are my most dedicated supporters and provide endless encouragement no matter what I pursue.

TABLE OF CONTENTS

Acknowledgments.	ii
List of Figures.	v
List of Illustrations.	vii
1.0 Introduction.	1
2.0 Site History.	3
2.1 Construction of the Citadel.	3
2.2 Construction Details of the Early Phrygian Gate.	7
2.3 Excavation and Conservation of the Citadel Gate.	16
2.3.1 Late Nineteenth-Century Discovery and First Excavations.	16
2.3.2 Mid-Twentieth-Century Excavations Directed by Rodney S. Young, 1950-1973.	16
2.3.3 Late Twentieth-Century Transitional Period and Conservation Efforts.	24
3.0 Environmental Conditions.	32
3.1 Climate.	32
3.2 Characterization of Soils.	33
3.3 Seismic Conditions.	35
3.4 Seismic Response of Historic Stone Structures.	36
3.4.1 Summary of Recent Literature.	37
3.4.2 General Properties of Historic Stone Structures.	43
3.4.3 Seismic Characteristics of Dry Stone and Multiple-Leaf Structures.	45
3.4.4 Analyzing and Diagnosing Damage from Past Events.	47
3.4.5 Discrete Element and Finite Element Methods of Modeling Historic Structures under Seismic Loads.	52
3.4.6 Effects of Strengthening on Historic Masonry under Seismic Loads.	63
3.4.7 Conclusion.	67

4.0 Dry Stone Structures.	68
4.1 Literature Review.	68
4.1.1 Introduction.	68
4.1.2 Review of Past Research and Current Literature.	69
4.2 General Design and Properties of Freestanding and Retaining Walls.	77
4.3 Observations on Failure.	80
4.3.1 Weathering and External Factors.	80
4.3.2 Toppling.	81
4.3.3 Bulging.	82
4.4 Conservation Methods for Dry Stone Structures.	83
4.5 Case Study: Great Zimbabwe National Monument.	86
5.0 Diagnosis of Existing Conditions.	89
5.1 Conditions Survey.	89
5.2 Limitations of Survey Methodology.	90
5.3 General Conditions Affecting the Citadel Gate.	93
5.3.1 Assessment of North Court Conditions.	95
5.3.2 Assessment of South Court Conditions.	101
5.4 Conclusions.	108
6.0 Recommendations for Future Testing and Monitoring.	112
6.1 Laboratory Testing.	112
6.2 Monitoring Structural Changes.	115
6.3 Modeling Seismic Behavior.	119
6.4 Further Research.	120
7.0 Conclusion.	123
Bibliography.	125
Appendix A	
Condition Drawings.	136
Appendix B	
Comparison Images.	171
Index.	184

LIST OF FIGURES

Figure 1.	View of the gate complex from the northwest.	1
Figure 2.	Aerial view of the Citadel Mound in 1965.	3
Figure 3.	Map of Iron Age Anatolia.	4
Figure 4.	Excavations to clear the Middle Phrygian building stones.	8
Figure 5.	South Court construction fill.	9
Figure 6.	Impression from timber foundation beam at North Court.	12
Figure 7.	Northeast corner of the South Court.	13
Figure 8.	Extant earthen plaster on the southeast elevation of the North Court.	14
Figure 9.	Excavations of the Early Phrygian entryway.	18
Figure 10.	Rubble fill laid during the Middle Phrygian period.	20
Figure 11.	Reconstruction of the southwest elevation of the North Court.	21
Figure 12.	The Polychrome House foundations.	23
Figure 13.	Cap on the South Court.	26
Figure 14.	The scaffolding erected after the Izmit earthquake.	28
Figure 15.	Gravity grouting process applied to the South Court.	29
Figure 16.	Map of the fault lines surround Central Anatolia.	35
Figure 17.	Vertical crack produced by seismic action.	48
Figure 18.	Failed corner of a multiple leaf system.	49
Figure 19.	Application of FE mesh to a historic structure.	53
Figure 20.	FE model showing shear failure in a dry stone wall.	54
Figure 21.	Simulation of column showing failure at the base.	58
Figure 22.	Failure in the upper blocks of a column.	59
Figure 23.	Column modeled with existing conditions.	60
Figure 24.	Changes in failure due to existing conditions.	61
Figure 25.	Individual meshes applied to Aachen Cathedral, Germany.	62
Figure 26.	The complete mesh of the Aachen Cathedral, Germany.	63
Figure 27.	Analysis of out-of-plane bending, Farneta Abbey, Italy.	65
Figure 28.	Model of Farneta Abbey, Italy.	66
Figure 29.	Great Zimbabwe National Monument, Africa.	86
Figure 30.	Excavation of the gate entryway.	95
Figure 31.	Molded clay which formerly surrounded structural timbers.	96
Figure 32.	Southeast elevation of the North Court showing vertical cracks.	97
Figure 33.	Southern wall of the North Court interior.	98
Figure 34.	East interior wall of the North Court.	99

Figure 35. Northeast elevation of the South Court.	102
Figure 36. Bulge in the South Court wall.	103
Figure 37. The east elevation of the South Court.	104
Figure 38. Cracking in northeast elevation of South Court.	105
Figure 39. The general instability of the South Court.	108
Figure 40. Concrete cap failure.	109
Figure 41. Drain in the concrete cap.	111

LIST OF ILLUSTRATIONS

Illustration 1. Site plan of the Citadel Mound.	5
Illustration 2. Section of multiple leaf wall.	10
Illustration 3. Modeling techniques for mortared systems.	56
Illustration 4. Burgoyne's test walls with incline and outer batter.	70
Illustration 5. Burgoyne's test walls with inner batter and vertical face.	71
Illustration 6. Section of dry stone wall.	78
Illustration 7. Soil nailing.	85

1.0 INTRODUCTION



Figure 1. View of the gate complex from the northwest. *By Wong, 2006.*

The ancient Phrygian capital of Gordion, Turkey contains some of the most significant and unique monumental architecture dating to the Iron Age. As the largest extant gate to survive from this period in the Middle East, the Early Phrygian fortifications are a structurally complex system, threatened by the seismically active environment of Central Anatolia. The multiple leaf dry stone construction of the main gate consists of an outer limestone and rhyolite veneer with inner rubble core and is susceptible to core settlement and movement. Excavated in the 1950s, the gate has been exposed to environmental conditions for six decades and has exhibited a series of vulnerabilities requiring evaluation and monitoring.

The gate's current conditions include extensive cracking, spalls, split faces, missing chinking stones, open joints and in- and out-of-plane displacements, which partially result from the complex history of the site. Constructed around 900 BC, the Early Phrygian Gate only briefly served as the main entryway to the citadel. Inhabitants from later periods continuously restructured the citadel mound, always utilizing the earlier structures as foundations for new construction. The changing load patterns resulting from different building campaigns caused a series of visible structural conditions—most notably cracking and displacement. Though cracking previously occurred from additional loads of the later city walls, displacement continues to be an active condition. Presently, several agents potentially threaten the gate's stability and include weathering and ground movement.

Over the past few decades, concrete capping, subsoil drains and injection grouting have been implemented at the site as reactive measures to inhibit water ingress and prevent further bulging; however, a more diagnostic approach is necessary to respond to any future damage and collapse, which may result from seismic activity. This research presents a synthesis of the existing knowledge pertaining to the behavior of masonry when subjected to seismic conditions, properties of dry stone structures and site-specific characteristics—such as existing conditions, climate, soil properties, construction techniques and past interventions—as a basis for developing recommendations for future monitoring and stabilization efforts.

2.0 SITE HISTORY



Figure 2. Aerial view of the Citadel Mound in 1965. *From the Gordion Archives, 1965.*

2.1 Construction of the Citadel

Currently situated approximately 100 km southwest of Turkey's modern capital of Ankara, Gordion developed along the Sakarya River in the Central Anatolian plateau. For the earliest inhabitants, the land offered an opportunity for agricultural development and later emerged as a trade center along Eastern Mediterranean networks. As a result of its prominent location, the citadel was susceptible to expanding empires and various periods of occupation, which contributed to the diverse history and multiple layers of archaeological evidence uncovered at the site throughout the past hundred years.

Serving as the ancient capital of Phrygia, Gordion's history spans beyond the Phrygian period and encompasses several millennia of successive civilizations. Throughout the various periods of inhabitation, innumerable cultures buried, reconstructed, modified and expanded the citadel and adapted it to serve a variety of functions. The Old Citadel—belonging to the Early Phrygians—survived buried beneath a later city since 800 BC, while the new city endured in various forms for nearly three millennia before its abandonment and burial. The burial process, which left both early and later citadels covered beneath a mound of earth, protected structures and artifacts to be discovered by later excavations.



Figure 3. Map of Iron Age Anatolia with Gordion serving as the ancient Phrygian capital. *From Kealhofer, 2005.*

The timeline extends from the Early Bronze Age to the Middle Ages; however, Gordion is perhaps best known for its association with King Midas and Alexander the Great. Remnants of the Early Bronze Age occupation remain buried below the Early Phrygian layer, but specific interest in understanding the Phrygians and their culture has left the earliest stratum unexplored. Though the city—and particularly King Midas—was referred to in ancient texts, little was known of the Phrygian civilization prior to explorations at Gordion. Scholars believe that the Phrygians migrated from southeastern Europe following

the collapse of the Hittite empire and eventually established Gordion as their culturally rich capital in Central Anatolia.¹

The excavated mound offers scholars the scarce opportunity to understand the Phrygian culture through the objects, art and architecture found at the site. The dearth of evidence outside Gordion underscores the importance of the remaining courts, megarons and tumuli revealed within the citadel mound. Items such as pottery, glass, mosaics, bronze vessels, furniture and textiles have been preserved by clay fill and provide the basis for understanding the Iron Age civilization. Specifically, the devastating fire of 800 BC left behind the most informative layer of Phrygian culture. The objects discovered within this Destruction Level have contributed greatly to the present knowledge of the ancient language, politics, crafts and social hierarchies at Gordion.

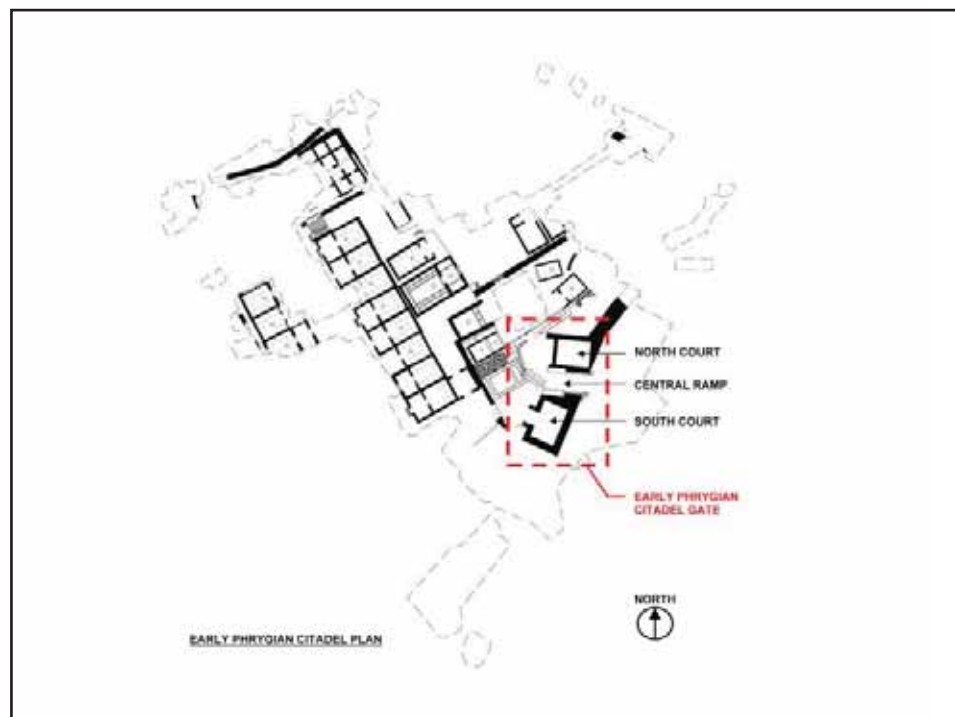

Illustration 1. Site plan of the Citadel Mound during the Early Phrygian period. *From Albinger, 2002.*

1 G. Kenneth Sams. "Midas of Gordion and the Anatolian Kingdom of Phrygia." In *Civilizations of the Ancient Near East, Vol. II*. Jack M. Sasson, John Baines, Gary Beckman and Karen S. Rubinson, eds. New York: Simon & Schuster Macmillan, 1995, 1147.

The height of the Phrygian civilization—originally believed to have been the Early Phrygian period of 900-800 BC—includes King Midas’s rule and spans from 800-540 BC. Known as the Middle Phrygian period, this era initiated the second major building campaign at the citadel mound. Following the catastrophic fire around 800 BC, the earlier city was covered with several meters of clay construction fill to provide a level foundation for the new structures. These later buildings closely mirrored the Early Phrygian structures below, though the Middle Phrygian citadel was expanded beyond the early borders. During this period of occupation, the Middle Phrygians thrived with a culture developed around textile production and food processing.

The interior of the mound, divided into three districts, included a Palace Area, megarons and a multi-roomed structure. A street extended through the megaron district. Each structure contained an antechamber and main hall and lined the street in rows, facing inward, to offer symmetry to the district. Both the Early Phrygian and reconstructed Middle Phrygian cities reflected this interior design.

The area immediately surrounding the citadel mound is a vast landscape of tumuli that reveals important information on Phrygian burial practices. Eighty-five earth mound tumuli of varying size surround the citadel, with the largest referred to as Tumulus MM (Midas Mound). Originally attributed to King Midas, recent research suggests that the tomb predates Midas’s death (ca. 700 BC). Currently believed to date to 740 BC, the tomb may have been constructed for Midas’s father and is generally believed to be a royal tomb given its size, design and the wealth of goods found within.²

The fall of the Phrygian Kingdom has been attributed to the invasion by the

² Richard F. Liebhart and Jessica S. Johnson. “Support and Conserve: Conservation and Environmental Monitoring of the Tomb Chamber of Tumulus MM.” *The Archaeology Of Midas And The Phrygians Recent Work At Gordion*. Lisa Kealhofer, ed. New York: University of Pennsylvania Museum Publication, 2005, 191.

Kimmerians, which ended in King Midas's death.³ Following the king's death, the Phrygian citadel was subject to control by outside powers, such as the Lydians and Persians, until Alexander the Great initiated the site's transition to a large Hellenistic town. The site endured a period of Roman influence and sporadic settlement through the late Ottoman period, though settlement migrated west of the Phrygian mound.

Undisturbed for several centuries, the citadel mound was discovered at the end of the nineteenth century by German Classicist Alfred Körte. Körte and his brother initiated a brief series of excavations at Gordion that reached levels dating to the 6th century BC. During this time, the Körtes focused efforts on opening several burial mounds and exploring localized areas of the main settlement mound. Though the excavations were short-lived, the investigations succeeded in generating international interest in the site.

Large-scale excavations began in 1950 by a team of archaeologists from the University of Pennsylvania. Directed by Rodney S. Young, the excavations revealed the rich underlying history which spanned several millennia. Interested in learning about the relatively unknown Phrygian culture, the archaeologists removed the later strata to expose the Early Phrygian citadel. The structures relating to Gordion's early period of Phrygian occupation remain uncovered and attest to the Iron Age civilization's advanced understanding of monumental architectural design.

2.2 Construction Details of the Early Phrygian Gate

As the largest extant gate to survive from the Iron Age in the Middle East, the Early Phrygian gate is remarkable for its design and construction. Situated at the southeastern edge of the citadel mound, the monumental gate complex functioned only briefly as

³ Sams. "Midas of Gordion and the Anatolian Kingdom of Phrygia." 1148.

the main entryway for the Early Phrygian city. When it was constructed in the mid-9th century BC, the city gate provided a grand, ramped entryway to an expanding city. After a catastrophic fire at the end of the 9th century BC, which marked the end of the Early Phrygian period of occupation, the gate complex was buried under rubble stone and 3-5 meters of clay construction fill.⁴ As excavations of the site commenced in the 1950s, archaeologists uncovered multiple construction layers; later occupants constructed buildings directly above the Early Phrygian structures. The gate's utilization as a foundation for later structures has left the underlying walls with a series of compression cracks, open joints and split faces from the extensive load the gate supported for several millennia.



Figure 4. Excavations to clear the Middle Phrygian building stones. *From the Gordion Archives, ca. 1955.*

Since its discovery, the gate has remained partially excavated. Currently composed of two courts, the gate complex initially included an early gate house—demolished prior to

4 Rodney S Young, “Gordion Preliminary Report – 1953.” *American Journal of Archaeology* (1955) 59: 1-18.

the catastrophic fire in 800 BC to allow for a drainage system—in addition to the still extant North and South Courts. Only evidence of the foundations remain to indicate the location of the earlier gate house and its corresponding city walls; however, the North and South Courts have survived with their walls largely intact—though the interior of the South Court remains unexcavated.



Figure 5. Only the South Court's entryway facade was excavated; clay construction fill remains in the interior court. *From the Gordion Archives, ca. 1955.*

This earlier entrance building--known as the Polychrome House—was so named for the colored building stone used in its construction, though it always functioned as a gate.⁵ During construction of the monumental gate complex, the Phrygian builders incorporated the earlier Polychrome House into the larger gate design. It then served as the inner entrance to the Early Phrygian citadel following the eastern expansion of the complex. The new, ramped entryway extended 23 meters from the outer citadel gate walls to the inner

⁵ Keith Devries. "The Gordion Excavation Seasons of 1969-1973 and Subsequent Research." *American Journal of Archaeology*, Vol. 94, No. 3. (July 1990), 373.

Polychrome House and measured 8.6 meters in width; lined with egg-sized cobble stones, the ramp rose approximately three meters over the entire distance of the entryway.⁶

North and South Courts flank the formal entrance. The court walls lining the ramp vary in height; however, the outer defensive walls stand nearly ten meters in height. The court walls—with the exception of the entryway walls which once adjoined the Polychrome House—comprise a three leaf dry laid system of a single wythe of outer veneer blocks and an inner rubble core. The ashlar veneer faces consist of substantial limestone and rhyolite blocks, which are cut and tooled on the exterior and left roughly shaped toward the core. Blocks are generally 1.5' in width and 3' in height, and laid in regular courses with occasional headers to bond the veneer into the rubble core.

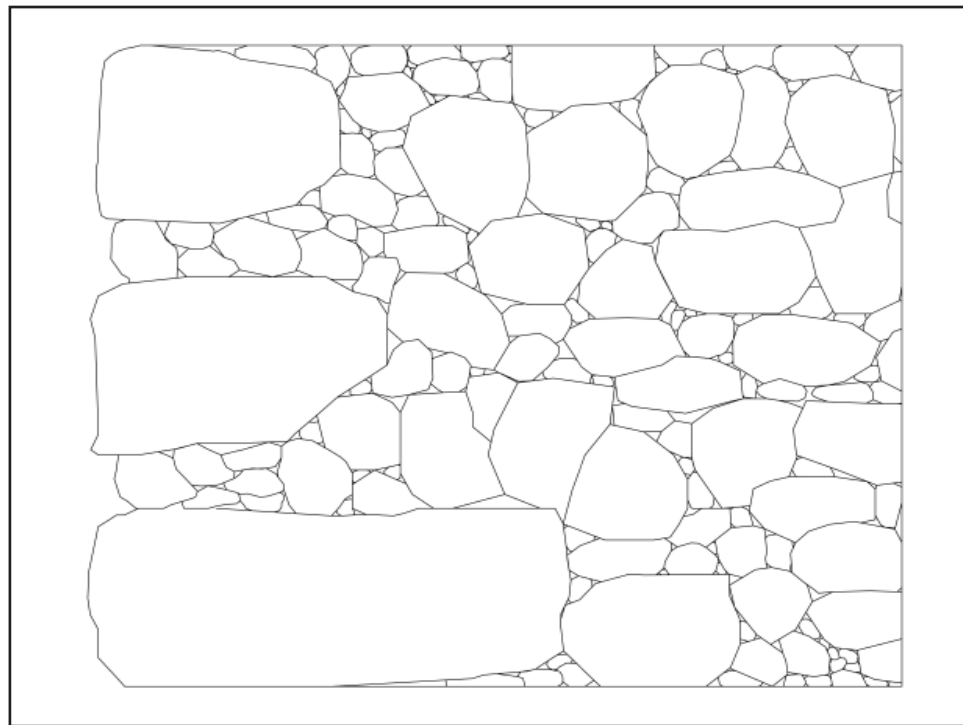

Illustration 2. Section of wall showing outer veneer with chinking stones and rubble core. *Keller, 2009.*

⁶Young. "Gordion Preliminary Report – 1953." 257.

Although the gate appears to be constructed of mostly limestone, rhyolite appears to have been used in greater quantity at the top of the walls. The characteristic dressed tooling on the face of the veneer stones was probably created with a wide, slightly rounded chisel.⁷ Because the dry laid construction left open joints between the head joints of the veneer stones, small chinking stones were inserted into the voids to increase stone contact for additional stability.

The stacked rubble core also consists of limestone and gains cohesion from timber beams, which served as a tying mechanism to bind the veneer and core. Though this critical structural component was assumed to be present within the multiple leaf system—especially given the presence of wooden tie beams found in other Early Phrygian buildings within the citadel mound—evidence of their use was not discovered until 2003. The wooden ties ranged in size from 20-30 cm in diameter, though much of the structural wood found at the site has since disintegrated.⁸

Other wooden components include the timber used as foundation beds for the massive stone masonry walls. The form of the disintegrated timber remains molded in areas where the rough logs were bedded in clay.⁹ These logs carried the weight of the outer face of the northern wall of the entrance ramp (and presumably of the southern wall).¹⁰ Though the disintegration of the wooden structural supports produced some instability (noted by Young in his 1955 excavation report), the walls of the formal entryway appeared generally stable at the time of excavation due to the design and construction methods.¹¹

The Phrygians employed several construction techniques to keep the walls

7 Rodney SYoung, "Gordion: Phrygian Construction and Architecture." *Expedition 2* (1960) 2: 9.

8 Goodman, Mark M. *Site Conservation at Gordion: Summer 2003*. Gordion Excavation Project 2003, 1.

9 Young, "Gordion: Phrygian Construction and Architecture." 4.

10 Rodney SYoung, "The Campaign of 1955 at Gordion." *American Journal of Archaeology* (1956) 60: 259.

11 *Ibid.*, 259.



Figure 6. Impression from timber foundation beam at North Court. *From the Gordion Archives, ca. 1955.*

inherently stable—particularly battered faces, stepped outer walls and masonry bonded corners. Perhaps the most critical among these is the batter of the outer faces. The North and South Court walls lack a consistent batter, however, most walls contain some degree of incline—though the interior faces of the North Court are vertical. The walls flanking the central ramp at the entryway contain a batter of five centimeters for every one meter of height.¹² Additionally, the outer defensive walls were constructed with a battered face above a double ledged base that steps in at varying heights and depths (from 2.73 meters to 0.45 meters) to create the ledges. Though the area above the high ledge is battered, the wall face below that point maintains a vertical orientation.¹³ The corners of these outer walls are masonry bonded, as well as battered, to interlock the limestone blocks and prevent

12 Mark Goodman, “Architectural Conservation at Gordion.” *The Archaeology Of Midas And The Phrygians Recent Work At Gordion*. Lisa Kealhofer, ed. New York: University of Pennsylvania Museum Publication, 2005, 217.

13 Rodney SYoung, “The Campaign of 1955 at Gordion.” 259.

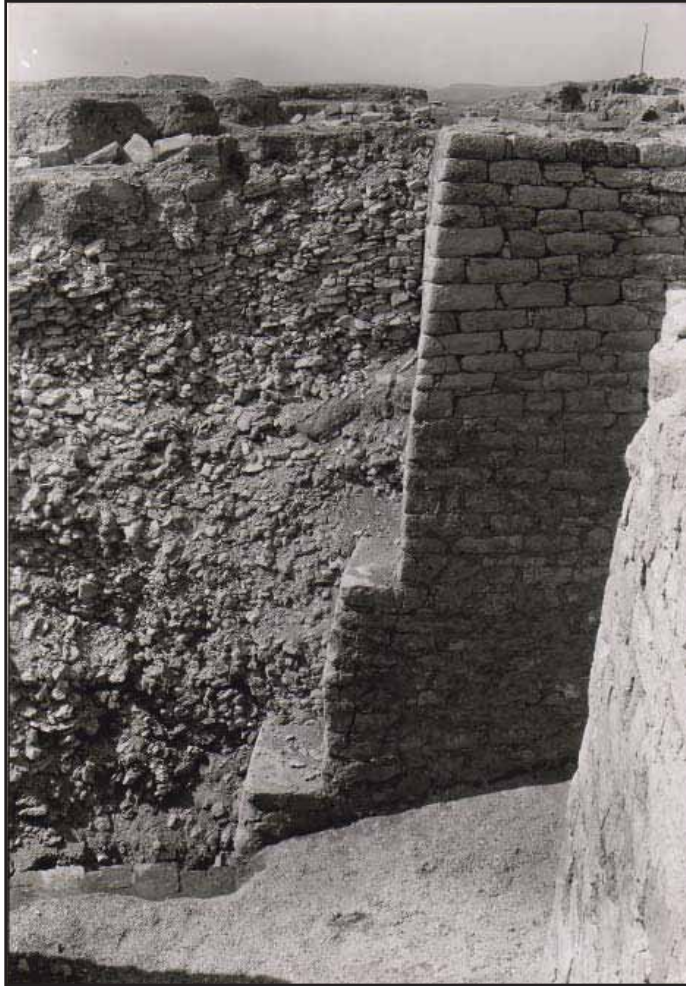

Figure 7. Northeast corner of the South Court showing the series of ledges discovered during excavation. *From the Gordion Archives, ca. 1955.*

separation or displacement at these vulnerable areas.

An earthen plaster finish originally covered both the interior and exterior court walls, remnants of which were clearly visible during excavation in the 1950s. Much of the plaster was noted on the walls of the central gateway and the adjoining court walls.¹⁴ The plaster on the flanking walls showed signs of deterioration from the pressure of the construction fill, which pushed against the gate walls for millennia; however, white lime powder was still visible and appeared to be whitewash residue.¹⁵ Much of the plaster

¹⁴Young, "Gordion Preliminary Report – 1953." 13.

¹⁵Young, "The Campaign of 1955 at Gordion." 258.

has since been lost due to its exposure to environmental conditions and, as of 2006, only remnants of the earthen finish remain on the southeast exterior elevation, areas of an interior North Court wall, and as broken plaster keys in many of the head joints.¹⁶



Figure 8. Extant earthen plaster on the southeast elevation of the North Court. *From the Gordion Archives, ca. 1955.*

The extant plaster supported the possibility of the existence of a roofing structure over the central gateway and adjacent courts, since the plaster would otherwise have been extremely susceptible to weathering.¹⁷ Also, archaeologists discovered dividing walls composed of sun-dried brick bedded on wooden beams in the North Court and believe this court was used as an enclosed storage space.¹⁸ No evidence of supporting elements for a roofing system was found in the South Court, though this court remains partially unexcavated.

¹⁶ Kelly Wong. *Field Notebook: Gordion Architectural Conservation Citadel Gate 2006 Season*. Philadelphia: University of Pennsylvania, School of Design, Architectural Conservation Laboratory. 2006, 16-40.

¹⁷Young. "Gordion Preliminary Report – 1953." 13.

¹⁸Young. "The Campaign of 1955 at Gordion." 260.

The courts are not identical and show some disparity in size and wall angles. The North Court reaches 12.9 meters on its north-south axis and 16.20 meters east-west. The slightly larger South Court spans an area approximately 19 meters north-south by 12.5 meters east-west. The South Court walls maintain more consistency in thickness—averaging approximately 3 meters—while the North Court walls vary greatly (though are generally thinner than the South Court walls). The inconsistency of wall angle and thickness found between the structures is attributed to the pattern of construction. Because the city walls are situated on slightly different planes (with the North Court situated 0.60 meters behind the South Court wall), scholars suggest the Phrygians built the courts as separate units, which resulted in the planar discrepancy.¹⁹

Following the catastrophic fire, which devastated the Early Phrygian city around 800 BC, the later occupants (who inhabited the citadel during the Middle Phrygian phase), altered much of the early structures in order to reconstruct a new city. Material from the previous buildings served as foundations and paving stones in the Middle Phrygian citadel. Though the Early Phrygian gate was left largely intact, several areas were stripped of the limestone blocks for use elsewhere; those stones formerly installed in the gate were identified in the later constructions by the distinctive tooling on the outer face.²⁰ Young and his team found and recorded the stones which were removed from their original location within the Early Phrygian gate and reconstructed part of a court wall to increase the continuity of the structure.²¹

Because the successive occupants leveled the Phrygian buildings to provide an even surface for construction, the uppermost courses of the gate were removed; as a result,

19 Ibid., 259.

20 Young, "Gordion Preliminary Report – 1953." 11.

21 Young, "Gordion: Phrygian Construction and Architecture." 9.

the finish of the top remains unknown. However, it is likely that very few courses were removed by the Middle Phrygian builders. The gate currently stands largely intact, although excavation has greatly altered its load patterns and structural stability and has contributed to numerous conditions—both past and present.

2.3 Excavation and Conservation of the Citadel Gate

2.3.1 Late Nineteenth-Century Discovery and First Excavations

The first explorations of Gordion occurred at the end of the nineteenth century when German Classicist Alfred Körte located the Phrygian capital based on literary references, which described its relationship to the nearby Sakarya (ancient Sangarios) River.²² Körte and his brother, Gustav, completed a single, three-month excavation of the site in 1900. These preliminary excavations were conducted in five burial tumuli, and trenches were dug on the southwestern edge of the main settlement mound. The Körtes' excavations provided invaluable information regarding the Phrygians' distinct culture and politics and revealed new relationships with other cultures.²³

2.3.2 Mid-Twentieth-Century Excavations Directed by Rodney S. Young, 1950-1973²⁴

The next series of excavations at Gordion were undertaken by the University of

22 Kenneth G. Sams. "Gordion: Explorations over a Century." *The Archaeology Of Midas And The Phrygians Recent Work At Gordion*. Lisa Kealhofer, ed. New York: University of Pennsylvania Museum Publication, 2005, 10.

23 Ibid. Artifacts discovered in several tumuli suggest that the Phrygians traded with the Greek world during the late 7th-mid-6th century BC—a fact not previously known to scholars. The Phrygians were believed to be under Lydian control during this period with no contact with the Greek world.

24 Records of the excavations exist in Young's journals and in publications by Young and other archaeologists working at the site. Thorough accounts from each excavation season can be found in the preliminary reports pertaining to a particular year (1953-1973). The Gordion archive resides at the University of Pennsylvania Museum of Archaeology and Anthropology and contains comprehensive documentation of the site since the university became involved in the excavations.

Pennsylvania under the direction of Rodney S. Young. These excavations commenced in 1950 and continued for over 17 seasons when, after 1973, activity at the site temporarily ceased. During this early excavation phase, only minimal conservation efforts were implemented to prevent deterioration. These efforts primarily focused on inhibiting water ingress and stabilizing localized areas of the structure.

1953 Excavation Season

Archaeologists had started excavations of the monumental gate complex the previous season and uncovered parts of the Middle Phrygian Gate, which was constructed on an Early Phrygian foundation. The successive builders filled the Early Phrygian remains with several meters of clay and stone block and rubble fill²⁵ to create a level foundation from which to build. The Middle Phrygians largely extended the Early Phrygian Gate walls several meters in height with new stone blocks to form the later gate structure. Construction by a series of later inhabitants (Phrygians following the 800 BC fire, possibly Lydians and Perisans) denotes the Middle Phrygian period of Gordion's chronology.²⁶

In this early phase of the citadel's excavation history, archaeologists continued to clear the fill from localized areas to understand the underlying Early Phrygian remnants. After excavating the sixth-century gate the previous season, Young's team resumed work on the South Court and revealed part of the outer South Court fortification wall (which extended on the north-south axis and was cleared to a depth of four meters). In his *Preliminary Report* of the 1953 season, Young described the materials and construction of this underlying wall:

²⁵Young. "The Campaign of 1955 at Gordion." 252. The rubble fill installed by the Middle Phrygians reached a depth of 9.5 meters from the top of the early Phrygian wall to the paving of the new citadel's gateway.

²⁶Sams. "Gordion: Explorations over a Century." 20.

It is built of brownish-gray limestone, not very hard, in roughly shaped blocks with characteristic tooling, probably made by the chisel, on their exposed faces. The blocks are laid in irregularly horizontal courses; the joints are not tight, and in many places the spaces between blocks – especially at the corners – are chinked with small splinters of the same stone. The space between the two built faces, inner and outer, is occupied by a filling of stone rubble.²⁷



Figure 9. Excavations of the Early Phrygian entryway. *From the Gordion Archives, ca. 1955.*

By clearing away the Middle Phrygian-period fill and exposing this section of Early Phrygian wall, the archaeologists discovered the three-wythe veneer and rubble wall system employed by the Phrygian builders. Additionally, observations were made on the differences in stability between the upper Middle Phrygian and lower Early Phrygian walls. Young noted that the later buildings showed evidence of displacement; walls tended to move relative to slopes in the foundation.²⁸ This sliding observed in the Middle Phrygian walls was not apparent in the Early Phrygian walls. Young reported on the stability of the Early

²⁷Young. "Gordion Preliminary Report – 1953." 11.

²⁸ *Ibid.*

Phrygian construction and its apparent use as a dam and “firm foundation against sliding and settling,” which provided significant structural support to the upper Middle Phrygian walls.²⁹ Those walls not constructed directly above the Early Phrygian structures were susceptible to displacement; with little foundational support – being situated only on the clay and rubble fill below – the walls at the edges of the citadel mound showed a higher degree of instability, since the Middle Phrygian circuit wall extended approximately 18 meters east of the Phrygian wall. During this 1953 season, archaeologists also partially uncovered a dam wall situated on the western section of the gate complex.

1955 Excavation Season

Reports of the 1955 season detailed the methods the successive builders employed when filling the earlier gate. Young described the system used to stabilize the Early Phrygian construction, and explicated how it served as a strong foundation for the later buildings. Rather than haphazardly piling several meters of rubble fill within the bounds of the Early Phrygian citadel which would cause instability and apply significant lateral loads to the gate walls, the later occupants systematically constructed a series of retaining structures and filled behind them to prevent large-scale sliding of the rubble fill. The Middle Phrygians utilized a dry stone construction method similar to the earlier inhabitants and carefully stacked the rubble fill approximately 1.2 meters thick behind each wall. As the Middle Phrygians filled the dry stone retaining structures with rubble, they threaded wooden logs within the fill and wall face to act as ties for added support.³⁰ Surrounding the Early Phrygian gate walls, a bank of hard clay was found, which reached approximately two-thirds of the original wall height. The clay bank was believed to have prevented lateral pressure

²⁹ Ibid.

³⁰ Young. “Gordion Preliminary Report – 1955.” 253.



Figure 10. Rubble fill laid during the Middle Phrygian period. *By Wong, 2006.*

from the rubble fill above and behind the gate walls.³¹

The continued excavation of the gate confirmed Young's discovery in 1953: unless the underlying Early Phrygian structure provided support for the later buildings, only a few courses remained of those earlier, unused walls.³² As Young's team uncovered more of the gate and its north and south courts, they revealed subtle variations in wall construction and condition. Though most walls were constructed with a batter, several walls in the north court were built with vertical faces. Young noted that the batter increased stability and allowed the walls to remain intact for several millennia.³³ Unlike most walls, the gate's outer entrance walls contained several steps to accommodate the transition from a broader

31 *Ibid.*

32 *Ibid.*, 257.

33 *Ibid.*, 258.

base to the upper battered portion. Young recorded a difference in performance between these two portions; the wall below the batter has cracked and appears to have deflected inward, while Young did not note these same conditions in the battered upper portion.³⁴



Figure 11. Reconstruction of the southwest elevation of the North Court. *From the Gordion Archives, ca. 1955.*

During the 1955 campaign, workers dismantled the Middle Phrygian damn wall and, due to the challenge of disposing of so much stone, used the blocks to reconstruct the inner southwest wall of the North Court.³⁵ After this season, the gate had been mostly cleared to the level of the Middle Phrygian town and some instability was evident. Over the course of the next three excavation seasons, workers incorporated rubble debris as buttressing for areas in need of additional structural support.³⁶

34 *Ibid.*, 259.

35 *Ibid.*, 258.

36 Frank Matero. *Field Report, Gordion Excavation, Turkey*. Philadelphia: University of Pennsylvania, School of Design, Architectural Conservation Laboratory. July 5, 2005.

1956 Excavation Season

Excavation work on the gate during this fifth season proved to be less intensive than prior seasons and shifted focus to some of the outlying areas, such as a minor mound to the southeast and the cemetery. After reaching the Middle Phrygian level of the gate complex the previous season, excavation efforts of this structure lessened.

Noticeable deterioration resulting from water ingress instigated the first major conservation effort of the Early Phrygian Gate. A concrete cap was installed on much of the North Court (though a large portion of the southern wall was never capped).³⁷ The concrete cracked soon after installation and failed to prevent water penetration to the rubble core. However, the cap remained in place for about thirty years before being replaced.

1957-1967 Excavation Seasons

Archaeologists continued to clear rubble and expose the Early Phrygian gate and other structures within the citadel mound. The 1961 investigations of the early gate complex allowed Young's team to delineate the various structures unearthed during earlier excavations. Over the course of these few seasons, several structures relating to the Early Phrygian gate had been uncovered, but the relationship remained unclear.

Though it had been excavated in earlier seasons, the Polychrome House (denoted as such based on the various colored stones used in its construction) remained somewhat perplexing to archaeologists attempting to establish a chronology of the gate complex. Adjacent to the interiors of the North and South Courts, it was clearly contemporary to the Early Phrygian gate but contained distinct qualities that suggested a slightly different

³⁷ Mark H. Rogers. *Site Conservation at Phrygian Gordion*. Honors Thesis. University of North Carolina at Chapel Hill, Department of Art. 1989, 11.

construction date (though it was unclear whether it pre- or post-dated the adjacent courts). Of different stone and situated on a slightly different axis, the Polychrome House held no immediate and obvious relationship to the Early Phrygian gate complex. However, after the 1961 discovery of an earlier city wall which aligned with and was constructed of materials similar to the Polychrome House, Young's team confirmed the chronology and determined that the Polychrome House—found to be an earlier gate rather than a house—and city wall predated the Early Phrygian gate. During the 1963 excavation, the team discovered a portion of the Early Phrygian gate constructed above an earlier wall, which dated from the previous construction period and related to the earliest city wall and the Polychrome House.³⁸ These discoveries verified the chronology and established the Early Phrygian gate complex as the second building campaign with several structural components built above existing fabric.



Figure 12. The Polychrome House foundations were uncovered at the interior of the main entryway. *From the Gordion Archives, ca. 1955.*

38 Rodney S. Young. "Gordion Preliminary Report – 1963." *American Journal of Archaeology* (1964), 291.

1969-1973 Excavation Seasons

Though excavation work continued at the site for the next few seasons, efforts were primarily concentrated on areas within the citadel walls rather than the gate itself. These excavations offered further insight into the catastrophic fire determined to have occurred around the end of the 9th century BC. Termed the “Destruction Level,” the fire provided an informative stratum at the ancient citadel which delineates the Early and Middle Phrygian periods of construction.

2.3.3 Late Twentieth-Century Transitional Period and Conservation Efforts

Excavation of the gate had been largely completed prior to the 1973 season, however, other areas within the citadel mound were still in-progress. However, Young’s unexpected death in 1974 caused a halt in excavations at the site for more than a decade. Excavations did not resume until 1988 (under the direction of Mary Voigt), and during the hiatus only minimal conservation efforts were made to arrest major deterioration.

1970s Site Conservation

Until just before excavations resumed, little effort was made to monitor or conserve the exposed gate complex. The structure and surrounding excavated buildings suffered from erosion and other weather-related mechanisms. By 1978—with a noticeable decline in condition—the gate was documented through drawings and photographic records to monitor changes and provide some indication of the rate of deterioration.³⁹ Work during the next two years centered on stabilizing abandoned trenches and reconstructing an ancient drain, which existed in the center of the gate complex.

³⁹ *Gordion Notebook 169*. Philadelphia: Gordion Archives at the University of Pennsylvania Museum of Archaeology & Anthropology (Written by Rodney S. Young).

1986-1989 Site Conservation

Until the late 1980s, very few interventions had been implemented to stabilize the gate or inhibit moisture ingress. Only the installation of the concrete cap in 1956 and some rubble buttressing provided any level of protection. Because the 1956 cap did not span the entire length of the gate, certain walls were left more susceptible to the environment. Evidence of increasing instability emerged in the partially excavated South Court of the gate complex. Large cracks and a bulge not apparent during excavation of the outer walls had formed in the northern wall. This bulge indicated that movement in the South Court walls was likely active and some stabilization method would be necessary to prevent collapse. In 1986, conservators installed a series of glass tell-tales⁴⁰ over potentially active cracks to record any displacement over the next few years; however, by the following year the tell-tales revealed signs of active movement.⁴¹

A lack of funding prevented conservators from implementing an extensive stabilization program, so a second monitoring scheme was installed in 1989 to supplement the glass tell-tales. This system used masonry nails set into various stones surrounding the South Court bulge. Recording the location of the masonry nails with a laser theodolite allowed for periodic monitoring to determine out-of-plane movement.

Water infiltration acted as the major, preventable decay mechanism affecting the gate's stability. The poor quality concrete cap installed in 1956 permitted water to migrate into the rubble core through a series of fractures. Additionally, the uncapped portion of the gate lacked any protection until the installation of a temporary clay cap in 1987. As a result, the gate walls were effectively subjected to water ingress for three decades.

⁴⁰Tell-tales function as crack monitoring devices. Fashioned from ordinary window glass, tell-tales are plastered to each edge of a crack. Active displacements crack the glass to indicate movement.

⁴¹Rogers, Mark H. *Site Conservation at Phrygian Gordion*. Honors Thesis. University of North Carolina at Chapel Hill, Department of Art. 1989, 15.



Figure 13. Cap on the South Court. *By Wong, 2006.*

Replacement of the failed 1956 cap occurred in 1989 with the installation of a new cement cap and drainage system. The new capping system acted as a trough and channeled water off the top of the gate. Though conservators arrested the water which infiltrated the old cap and migrated to the rubble core, further actions were required to slow the accelerating deterioration. Weathering of the limestone veneer continued, and mechanisms causing displacement remained active. Noticeable detachment of the load-bearing veneer blocks necessitated further assessment and conservation planning.⁴²

1990s Site Conservation and Planning

Throughout the 1990s, several conservators consulted on wall stabilization efforts. Much of the work done during this ten-year period involved planning and constructing a

⁴² Goodman, "Architectural Conservation at Gordion," 219.

preservation philosophy from which to formulate future interventions.⁴³ However, the high magnitude 1999 Izmit earthquake which struck northwestern Turkey forced conservators to refocus on implementation. Prior to the seismic event, movements were less than 1.5 cm; following the Izmit earthquake, measurements revealed movement of 3-4 cm around the center of the bulge, and several stones fell near the western interior corner of the South Court.⁴⁴ The structural monitoring system was then revised to include a series of plumb lines to measure incremental movement.

1999-Present Stabilization Program

Among those consulted on structural intervention at the beginning of the 1990s, Bernard Fielden proposed a grout injection program to bond the rubble core and outer veneer. The recommendation was accepted by Mark Goodman, who assumed the role of Director of Architectural Conservation in 1999. Goodman developed a grouting program, which outlined each action necessary to execute the grouting process⁴⁵:

- Stabilize the base by constructing an earthen berm
- Install structural bracing
- Start gravity grouting program⁴⁶
- Secure upper courses by repacking rubble core and pinning veneer

43 William Remsen (Director of Architectural Conservation, 1993-1998) advocated for a visionary conservation plan, which would address structural issues and work toward visual reintegration of the site. When Mark Goodman assumed the role of Director, he formalized conservation guidelines and created a priority program which targeted the site's excavated structures. "Architectural Conservation at Gordion: Summer 1999."

44 Goodman, Mark. *Architectural Conservation at Gordion: Summer 1999*. Gordion Excavation Project 1999, 5-6.
45 *Ibid.*, 6.

46 Gravity grouting is a process developed to increase the bond strength of a wall system by introducing grout into the joints. Injection pressure is produced by gravity to prevent excessive force from lifting or separating stones. The process targets the rubble core to improve cohesion, prevent further displacement and seismically strengthen the walls. During the gravity grouting process at Gordion, the mining railroad, which had been used during excavations was reconstructed to transport materials for the grouting program.



Figure 14. The scaffolding erected after the Izmit earthquake. *By Goodman, 2001.*

The gravity grouting effort began in 2002—after the scaffolding was positioned along the central gateway—and continued through the 2006 season. The grouting team first tested the method on a trial wall south of the gate complex. After successfully grouting the trial wall, the team resumed the injection grouting process on the unstable South Court walls. The grout selected was specified for the unique characteristics of the gate. Goodman recorded the formulation in his 2003 site report:

Two types of lime mortars were used in conserving the structure. These included a non-hydraulic lime mortar for exterior pointing, and a hydraulic mortar slurry specially formulated for structural grouting application. Although grout mortars vary in composition, the desired performance criteria are similar; high thixotropic qualities (flow) to penetrate the masonry core, good adhesion and low shrinkage to effectively consolidate masonry, and chemical/physical compatibility with the material to be consolidated. As grouts are injected into internal masonry they also need to harden in the absence of air (hydraulic set). While

many grout formulations use cement to achieve this, such cement-based mortars are too strong and impermeable and would accelerate deterioration of the friable limestone of the Citadel Gate. Other additives commonly used, such as fly ash, contain a significant % of soluble sulfates which are also harmful to porous masonry.

Under these conditions, the ideal grout binder is Hydrated Hydraulic Lime (HHL). A specialized hydraulic lime, *Cheax Blanche* from Lafarge Co., has a long track record of use in architectural conservation and was imported from France for this purpose....The grout formula, mixed as a wet slurry, combines HHL and local sand (Belikopru Olnm) with low fired pozzolanic brick dust added to enhance hydraulic set.⁴⁷



Figure 15. Gravity grouting process applied to the South Court. *By Goodman, 2001.*

⁴⁷ Goodman 2003 Site Report, 6-7.

The grout was first injected into the east elevation of the South Court and continued on both north elevations over four seasons (from 2002-2006). Currently only the lower 7-16 courses are grouted. Though the process was documented through rectified photographs to record the amount of mortar injected into the walls, the degree of stability attained from the process cannot be determined or assumed. The depth the grout traveled within the wall—and the bond created—remains unknown.

In 2005, Frank Matero, Chair of the Graduate Program in Historic Preservation at the University of Pennsylvania, conducted a site inspection of past conservation efforts. Of the most critical conditions, Matero noted structural settlement, the detachment of veneer stones from the rubble core (resulting in bulging) in the South Court, structural instability of the partially rebuilt west wall of the North Court and cracking of the 1989 concrete cap.⁴⁸ Following this examination, Matero took over the conservation program and continued investigations during the next several seasons.

Under Matero's guidance, Kelly Wong, a graduate student of the University of Pennsylvania Historic Preservation Program, assessed the properties of the grout used to stabilize the gate⁴⁹ and continued research at the site until the 2008 season. During that time, Wong and a team of conservators from UPenn and METU conducted a condition survey of the entire gate complex. They also worked on localized treatments, which included micro grout injections of the cracked stones on the lower levels of the northeast and east walls of the South Court and installed three crack monitors on the South Court.⁵⁰ The grouting program was discontinued after 2006 until a more thorough structural

48 Matero. *Field Report, Gordion Excavation, Turkey*.

49 See Kelly H Wong. "Assessment of the Grout Used for the Structural Stabilization of the Early Phrygian Citadel Gate at Gordion, Turkey." Thesis. University of Pennsylvania, 2006.

50 Kelly Wong. *Dossier: Citadel Gate Complex*. Philadelphia: University of Pennsylvania, School of Design, Architectural Conservation Laboratory. Summer 2006, Citadel Gate 6.

assessment and monitoring of the gate could be undertaken.

Results of Excavation Sequence

The discontinuities in the excavation process left the Early Phrygian Gate partially excavated and vulnerable to environmental conditions for thirty years before concrete plans were developed and implemented. As a result of the excavation process, Middle Phrygian stone blocks from the later gate remain on sections of the Early Phrygian structure (including the northwestern corner of the rear wall of the North Court and the southwestern end of rear South Court wall). These Middle Phrygian remnants stand 5-6 courses in height and have caused differential loads on the Early Phrygian walls.

As recorded in Young's 1955 Field Report, the later inhabitants constructed a series of retaining walls to prevent excessive loads on the early walls. However, the soil backfill still present in the partially excavated South Court exerts some lateral pressure on the walls. This lateral load can be especially detrimental to those walls which developed bulges after excavation. Though the structural stability of these walls has (theoretically) been increased by injection grouting, the load patterns and failure mechanisms require further investigation.

3.0 ENVIRONMENTAL CONDITIONS

Located in the interior Anatolian plateau of central Turkey, the ancient citadel of Gordion has been affected by environmental changes occurring over several millennia. The altered climatic conditions—in addition to anthropogenic effects such as fire, rebuilding, excavation and conservation—hold specific implications for understanding and interpreting past and current conditions of the structures and site. The 1950s excavations exposed many existing structures, leaving them vulnerable to environmental conditions for the past six decades and, especially in the case of the gate, altered the structure’s stability and response to lateral and compressive loads. Understanding climate, soil-structure interaction and the region’s seismicity is critical in diagnosing and predicting the gate’s response to ground movement and in developing a strategy to stabilize the structure and prevent further bulging or collapse.

3.1 Climate

Because of its location within Central Anatolia, Gordion does not have the same humid, mild conditions of Turkey’s Mediterranean coast. The region experiences somewhat harsher conditions with more significant temperature extremes. The climatic disparity occurs from topographical differences between the coastal and inland regions. Mountains

generally run parallel to the coastline and prevent any substantial precipitation from reaching the plains. As a result, the Central Anatolian region is characterized as semi-dry and receives only about 200-400mm (or approximately 8-15.5”) of precipitation annually, as compared to the average accumulation of 1,200mm (47”) gained in the coastal regions.⁵¹ The little precipitation that reaches Central Anatolia occurs mostly in winter in the form of snow, since temperatures average -2°C (28°F) during the winter months. The dry summers average 23°C (73°F).⁵² Even with low accumulation of precipitation, the climate provides the necessary conditions for freeze/thaw cycling and additional lateral pressure from moisture penetrating the soil backfill.

3.2 Characterization of Soils

The soil-structure interaction has significant implications relating to the stability of the Early Phrygian Gate. Knowledge of the bedrock and composition of the soil backfill not only provides some indication of the structure’s general stability but also increases the capacity to predict the gate’s behavior during seismic events. Additionally, the long history of occupation at the site has left several strata, which reveal land-use patterns, as well as periods of destruction and abandonment.

Several factors relating to soils and hydrology have determined the present condition of Gordion; the citadel’s proximity to the Sakarya River (known during ancient times as the Sangarios River) has affected the site for centuries—both during and after occupation—and greatly impacted the citadel’s current appearance and remaining structures. The Phrygians constructed the citadel on the Sakarya’s floodplain—elevated only 16 meters above the

51 *Devlet Meteoroloji İşleri Genel Müdürlüğü*. 13 Feb. 2009 <<http://www.meteor.gov.tr/2006/english/eng-climateofturkey.aspx>>.

52 Serhat Sensoy. “Climate of Turkey.” *Climate of Turkey*. 2007. Devlet Meteoroloji İşleri Genel Müdürlüğü. 13 Feb. 2009 <<http://www.dmi.gov.tr/index.aspx>>.

river.

Formed from rapidly evaporating lakes, silty marl provides the base layer of the citadel mound. The marl—lime-rich, porous and weakly consolidated—is found mostly undisturbed to the west of the Sakarya River, where the citadel mound is located.⁵³ Soil derived from these lime-rich marls generally lack nutrients and exhibit low moisture capacity. The earliest settlement was constructed upon the marl alluvium with successive soil layers of various clays and silts serving as foundations for later construction periods. A paleosol directly underlies Gordion's historic urban center and consists of heavily gleyed sedimentation and possibly results from agriculture during an early period at the site.⁵⁴ The Early Phrygian building foundations cut into the paleosol and were largely constructed directly above this stratum.

As the surrounding geological features and site habitation slowly morphed over centuries, the changes affected the Sakarya River's shape and flow. Several gradual alterations to the river's course and height have occurred due to human impact. The formerly straight banks began to curve as sediment load increased. As the river migrated toward the citadel, it encroached on weak outer buildings, which caused some loss to structures and buried areas of the citadel in the upstream area.⁵⁵ Centuries of occupation at the site have resulted in a four meter rise in the floodplain.

The most critical aspect currently affecting the Early Phrygian gate relates to the soil-structure interaction of the South Court backfill. It can be inferred from surrounding investigations that the construction fill used to provide foundational support for the

53 Ben Marsh. "Physical Geography, Land Use, and Human Impact at Gordion." *The Archaeology Of Midas And The Phrygians: Recent Work At Gordion*. Ed. Lisa Kealhofer. New York: University of Pennsylvania Museum Publication, 2005, 161.

54 Ben Marsh. "Alluvial Burial of Gordion, an Iron-Age City in Anatolia." *Journal of Field Archaeology* 26 (1999): 163-75. *JSTOR*. University of Pennsylvania. 9 Feb. 2009, 167.

55 *Ibid.*, 174.

Middle Phrygian structures is likely artificially transported clay from the nearby alluvial deposits. Heavily compacted over centuries, the highly expansive red fan clay construction fill provided a poor foundation for the later Middle Phrygian city. The unexcavated clay continues to exert lateral pressure on the South Court walls. This lateral force, combined with hydrostatic pressure, differential load and seismically induced movement, has contributed to the bulging visible in several elevations.

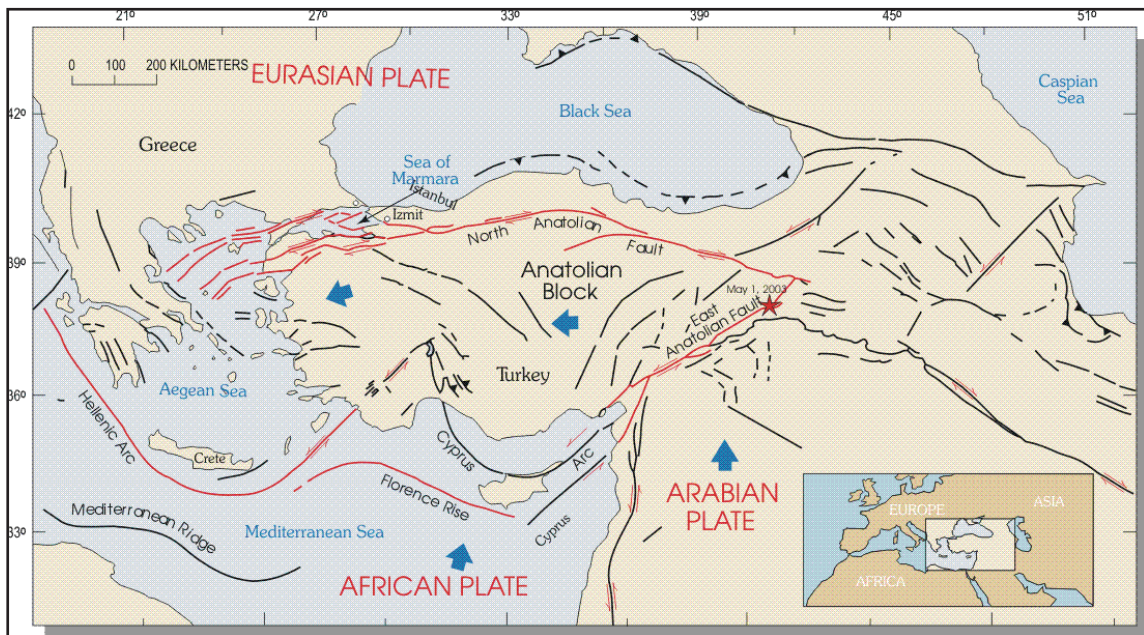

Figure 16. Map of the fault lines surround Central Anatolia. From www.usgs.gov.

3.3 Seismic Conditions

Centrally located between active fault lines, the citadel mound experiences frequent ground movements from various plates. A comparison of maps shows the correlation between major earthquakes and the North Anatolian Fault. Figure 16 illustrates the extent of Turkey's seismic area and delineates the highly active region surrounding the Central Anatolian plateau. Because Turkey is situated on a wedge of continental crust at the convergence of multiple plates—including the African, Eurasian and Arabian plates—

innumerable seismic events have occurred in the region surrounding Gordion over the past century; many of these earthquakes have registered at 6.0 or above in magnitude and have caused extensive damage to the built environment.⁵⁶

The citadel at Gordion is most affected by activity along the 1,500 kilometer-long North Anatolian fault line (NAF). High magnitude earthquakes (>6.7) have shown a westward migration along the fault. Built up stresses are found to be released approximately every twenty years; the Izmit segment ruptured in 1999 and caused significant ground movement at Gordion, which contributed to several centimeters of movement in the South Court bulge.⁵⁷ Calculations of targeted areas along the fault line have indicated an increase in stress provoked by past events. The frequency and severity of earthquake activity along this critical North Anatolian fault line leaves the Iron Age gate susceptible to large displacements, which could eventually lead to collapse if unsupported.

3.4 Seismic Response of Historic Stone Structures

Predicting seismic behavior in historic masonry structures presents innumerable challenges due to the variations in construction technique, existing conditions, the long history of adaptation and additions in many buildings and each structure's unique load patterns—many of which have shifted over time. Increasing accuracy of predicted behavior requires extensive knowledge of each factor. However, understanding general properties of masonry constructions allows for the anticipation of certain deformations or failure modes. These failure mechanisms—largely the result of in-plane movement and out-of-plane bending—are informed by in-field assessments of a specific structure combined with

⁵⁶ USGS. *Implications for Earthquake Risk Reduction in the United States from the Kocaeli, Turkey Earthquake of August 17, 1999*. Publication no. 1193. US Department of the Interior, 2000, 11.

⁵⁷ Mark Goodman. *Architectural Conservation at Gordion: Summer 1999*. Gordion Excavation Project 1999, 5-6.

knowledge of failures during past events or model simulations of the actual building system.

Field assessments and computer-generated models aid in identifying structural weaknesses that lead to failure under seismic loads. Predicting behavior allows for interventions prior to damage or collapse, and requires some accuracy in classifying possible failure modes. In-field assessments are limited by the correlation of past damage with the type of construction, prior weakness within the structure and magnitude of the seismic event. Similarly, computer simulations require inputs of force and geometries to calculate failure modes; existing conditions are a necessary component when quantifying damage mechanisms. Measures to overcome limitations from computer-generated models involve thorough assessments of existing conditions, nondestructive methods for identifying unknown load patterns and critical conditions, and considering (and modeling) multiple failure mechanisms, since failure modes are generally produced by dynamic actions during seismic events.

The ability to predict behavior—whether accurately or not—has led to preventive actions that attempted to inhibit the failure mechanisms of buildings under seismic loads. Traditionally, engineers and conservators have formulated strengthening programs based on conforming to modern code; this system precludes inherent qualities of historic masonry, which have allowed them to resist seismic loads in past events. Instead, engineers and conservators projected modern design standards onto these structures and molded the buildings into rigid, monolithic constructions without consideration of historic form, material compatibility or inherent resistance to seismic loads.

3.4.1 Summary of Recent Literature

Two distinct approaches have been employed to understand seismic behavior

of stone masonry structures—in-field analyses of failure modes and laboratory-based numerical modeling and experimentation. Though historically performed exclusively, current research has advocated for an integrated methodology as the most accurate and effective process of predicting behavior—and ultimately failure—of masonry systems. Research is focused primarily in European countries of high seismic activity, such as Italy, Greece and Turkey where both monumental and vernacular structures are used as case studies.

A review of recent literature illustrates how in-field and laboratory techniques have transitioned to this more integrated approach. Through early in-field research, typologies of earthquake damage have been established to provide a basis for understanding and assigning causality to historic masonry in seismic regions. The literature indicates that the laboratory process of determining seismic behavior has evolved through the use of discrete and/or finite element methods (DEM/FEM) to graphically represent structures, as well as through the use of shaking tables to simulate the response of large-scale structures. More recently, risk assessments have been developed as a means of both identifying construction weaknesses of buildings in the field and facilitating DEM and FEM representations by increasing the accuracy of the simulated models.

In-Field Observations of Seismic Damage

Developing damage typologies for stone structures in seismic conditions proved to be the simplest approach to understanding behavior. Langenbach's 1990 study analyzed construction techniques of masonry systems which survived previous seismic events.⁵⁸

The information provided insight into seismic-resistant construction for poor, rural

58 R. Langenbach. "Learning from the Past: Traditional and Contemporary Unreinforced Masonry in Seismic Areas." *Structural Conservation of Stone Masonry*. Greece, Athens. Rome: ICCROM, 1990. 343-354.

regions where strengthening or retrofitting is not financially viable. Langenbach—along with Erdik and his examination of stone buildings in Turkey—formulated a vocabulary for assessing earthquake related damage in masonry systems, which was then used to interpret prior damage and differentiate seismic damage from general weathering patterns and deterioration.⁵⁹ Because of the accessibility of this research, studies have continued to develop more advanced damage typologies and expanded the research to include other masonry systems, such as adobe and brick.^{60,61}

Numerical Modeling of Historic Stone Structures

The discrete element method (DEM) and finite element method (FEM) allow researchers to numerically model idealized or existing structures and chart seismic behavior. The DEM technique was originally applied by Peter Cundall in the 1970s to model the behavior of granular assemblies.⁶² The engineering field adopted the technology to numerically model new and historic structures. Though DEM accurately simulates properties of new structures (since construction techniques and materials are known) there are limitations in its application to historic structures due to the complexities inherent in masonry assemblies. To overcome DEM's limitations, knowledge of the construction methods, weathering patterns and material properties must be ascertained.

The initial application of DEM and FEM utilized idealized structures—such as

59 M. Erdik. "The Earthquake Performance of Rural Stone Masonry Buildings in Turkey." *Earthquake Damage Evaluation and Vulnerability Analysis of Building Structures*. Oxford: Omega Scientific, 1990. 57-77.

60 M.K. El Samny. "Structural Response during the 1992 Cairo Earthquake." *10th European Conference on Earthquake Engineering*. Austria, Vienna. Vol. 1. Brookfield: Balkema, 1995. 793-798.

61 Shmuel Marco. "Recognition of Earthquake-Related Damage in Archaeological Sites: Examples from the Dead Sea Fault Zone." *Tectonophysics* 453 (2008): 148-156.

62 P.A. Cundall and O.D.L. Strack. "A Discrete Numerical Model for Granular Assemblies." *Geotechnique* 29 (1979): 47-65.

columns and arches—to gain a general understanding of seismic behavior.^{63,64} Numerically modeled columns exhibited the complex geometries—created by fluting, etc.—of typical Greek columns, but failed to account for irregularities from weathering, material deficiencies or past interventions. As the DEM/FEM process developed, monumental structures were modeled with actual conditions shown in the simulation.^{65,66,67} Research focused on Greek temples to predict seismic behavior of unreinforced columns and also illustrated the altered behavior of the structure after seismic strengthening.⁶⁸

More recent published research on computer-generated modeling of seismic behavior has attempted to establish a multi-scale approach to simulation.⁶⁹ This approach requires identifying failure mechanisms at a macro (or structural) and micro (individual block) level. The initial construction of each model simulates behavior at corresponding scales and then allows for the macro and micro models to be combined into one multi-scale model. Current simulations require small (approximately 1 meter) wall constructions to operate, due to the large quantity of information processed during the simulation of micro-level behavior.

63 M. Demonstenous and G. C. Manos. “Dynamic Response of Models Subjected to Horizontal Motions.” *Structural Preservation of the Architectural Heritage*. Proc. of IABSE Symposium Rome. Vol. 70. Italy: IABSE, 1993. 361-368.

64 Engin Karaesmen, and Erhan Karaesmen. “A Study of the Structural Behaviour of Historic Masonry Buildings in Seismic Zones.” *10th European Conference on Earthquake Engineering*. Austria, Vienna. Vol. 2. Brookfield: Balkema, 1995. 927-933.

65 Joao Azevedo, Gabriela Sincaian, and J.V. Lemos. “Seismic Behavior of Blocky Masonry Structures.” *Earthquake Spectra* 16 (2000): 337-65.

66 M. Mistler, C. Butenweg, and K. Meskouris. “Modelling Methods of Historic Masonry Buildings under Seismic Excitation.” *Journal of Seismology* 10 (2006): 497-510.

67 Michele Betti and Andrea Vignoli. “Modelling and Analysis of a Romanesque Church under Earthquake Loading: Assessment of Seismic Resistance.” *Engineering Structures* 30 (2008): 352-67.

68 I.N. Psycharis, J.V. Lemos, D.Y. Papastamatiou, C. Zambas, and C. Papantonopoulos. “Numerical Study of the Seismic Behaviour of a Part of the Parthenon Pronaos.” *Earthquake Engineering and Structural Dynamics* 32 (2003): 2063-084.

69 Mark Ainsworth and L. Angela Mihai. “An Adaptive Multi-Scale Approach to the Modelling of Masonry Structures.” *International Journal for Numerical Methods in Engineering* (2008).

Laboratory Testing Using Shaking Tables

Several large-scale experiments were conducted to assess properties of structural assemblies using shaking tables. Watabe et al. simulated the impact of seismic activity on the Parthenon columns to identify failure due to weathering.⁷⁰ Weathering significantly affects performance and can increase possible displacements caused by decreased interface between blocks, which lowers static friction. A more recent experiment to identify performance characteristics specific to individual masonry assemblies concluded that no significant differences exist in mortared systems composed of either rubble or irregularly-shaped stones, since the mortar allows for greater energy dissipation.⁷¹ Vasconcelos et al. found that vibrations from the simulator did, however, impact dry stone structures—those that lack mortar—to a greater degree and cause higher levels of displacement, since these systems lack the energy dissipating properties found in mortared construction.⁷²

Though the shaking table experiments provide invaluable insight into the actual performance of masonry systems, they are limited in scale and scope. In an effort to validate both simulation methods, Pagnoni applied a DEM model to a constructed wall, which was also subjected to a shaking table test. Pagnoni confirmed that the discrete element method was able to predict the actual behavior produced by the shaking table test.⁷³ Though Pagnoni verified the accuracy of the methods with known constructions, historic masonry systems maintain some limitations and require extensive research of construction

70 M. Watabe, H. Aoki, T. Hanasato. "Earthquake Resistant Capacity of the Parthenon." *Structural Preservation of the Architectural Heritage*. Proc. of IABSE Symposium Rome. Vol. 70. Italy: IABSE, 1993. 345-352.

71 Graca Vasconcelos and Paulo B. Lourenco. "Evaluation of the In-Plane Seismic Performance of Stone Masonry Walls." 2005. *Repositorium*. Universidade do Minho. 7 Feb. 2009 <<http://repositorium.sdum.uminho.pt>>.

72 Ibid., 8.

73 T. Pagnoni. "Seismic Analysis of Masonry and Block Structures with Discrete Element Method." *10th European Conference on Earthquake Engineering*. Austria, Vienna. Vol. 3. Brookfield: Balkema, 1995. 1669-1674.

techniques and materials to produce accurate results from DEM models.

Vulnerability and Risk Assessments

During the past decade, the field of earthquake engineering has shifted some focus from computer-generated and laboratory modeling to in-field vulnerability assessments of individual structures as a measure of predicting potential failures.^{74,75,76,77} Binda et al. first argued for the need to understand actual building assemblies and current conditions before any modeling or interventions could be applied.⁷⁸ As a result, engineers and conservators designed several assessment methodologies to record construction methods and existing conditions; measured drawings were produced to examine geometries, past interventions and crack patterns of masonry walls. Nondestructive testing also served as a tool for investigating unknown building assemblies. The vulnerability assessments are intended not only to assign safety values to existing structures but also to increase the accuracy of DEM models by supplying a much greater amount of information for each structure subjected to seismic simulations.

Conclusion

The recent research conducted by universities in the US and Europe exemplifies this shift in focus. Faculty members of the University of Aachen in Germany have developed a

74 L. Binda, A. Saisi, and C. Tiraboschi. "Investigation Procedures for the Diagnosis of Historic Masonries." *Construction and Building Materials* 14 (2000): 199-233.

75 Luigia Binda and Antonella Saisi. "Research on Historic Structures in Seismic Areas in Italy." *Progress in Structural Engineering and Materials* 7 (2005): 71-85.

76 P.B. Lourenco and J.A. Roque. "Simplified Indexes for the Seismic Vulnerability of Ancient Masonry Buildings." *Construction and Building Materials* 20 (2006): 200-08. ScienceDirect. University of Pennsylvania, Philadelphia.

77 M. Altug Erberik. "Generation of Fragility Curves for Turkish Masonry Buildings Considering In-Plane Failure Modes." *Earthquake Engineering and Structural Dynamics* 37 (2008): 387-405.

78 Binda, Saisi, Tiraboschi. "Investigation Procedures for the Diagnosis of Historic Masonries."

more holistic approach to assessing and modeling historic monumental structures.⁷⁹ Mistler et al. have integrated the in-field assessments with the computer-generated DEM models of Aachen Cathedral to predict the behavior of the complex system under seismic conditions. Because the cathedral is composed of several different stone assemblies and exhibits various crack patterns, an accurate DEM model must simulate the behavior of each type of construction and project the anticipated changes and affects of the cracking.

The progress in computer simulations of seismic events indicates the potential of DEM in the field of conservation. However, research completed at MIT suggests that seismic behavior is still not wholly understood. Meyer et al. proved that high-frequency/low energy waves could adversely affect masonry walls—particularly those with multiple wythes and rubble fill—by causing partial densification and fluidification of the fill.⁸⁰ High-frequency waves were historically considered relatively benign during earthquake events. The recent discovery of the adverse effects of these waves on stone structures emphasizes the lack of complete understanding in the field. However, the current methods of assessing and simulating monumental buildings through DEM will allow conservation professionals to design monitoring programs, calculate potential failures and determine the need for seismic strengthening.

3.4.2 General Properties of Historic Stone Structures

Seismic behavior varies according to building construction (e.g. single leaf/multiple leaf structures, mortared/dry systems). Stone constructions carry certain general

⁷⁹ Mistler, Butenweg, and Meskouris. “Modelling Methods of Historic Masonry Buildings under Seismic Excitation.”

⁸⁰ Patrik Meyer, John Ochsendorf, John Germaine, and Eduardo Kausel. “The Impact of High-Frequency/Low-Energy Seismic Waves on Unreinforced Masonry.” *Earthquake Spectra* 23 (2007): 77-94.

characteristics when subjected to seismic loads; however, these characteristics hinge on building type. Bell towers, aqueducts, free-standing walls, columns and arches exhibit unique behavior, since the design of these structures differs from basic building construction.

Typical stone masonry structures were historically built with extra thick walls to compensate for seismic loads and, as a result, up to 90% of the mass is contained within the walls.⁸¹ Because of the incredible mass, many stone structures endure high amounts of deformation before failing. These structures experience the greatest susceptibility from horizontal loads, which causes out-of-plane bending; irregular or projecting components of a building (such as L- or U-shaped areas of the building plan) suffer more damage from horizontal loads.⁸²

Though rigid and well-connected floors strengthen stone constructions, buildings with multiple stories show less resistance to seismic loads. Surveys conducted following high magnitude events indicate the general resistance of historic structures to large seismic waves, likely due to their ability to deform heavily before collapsing. Modern buildings can be hindered by the rigidity of construction, which produces an inelastic, monolithic structure, and experience failure when subjected to severe vibration.⁸³ This difference is due to the extent of elasticity inherent in historic stone structures.

81 F.V. Karantoni, M.N. Fardis, and D. Matraka. "Comparative Study of the Seismic Response of Stone and Brick Masonry Buildings." *Structural Studies, Repairs and Maintenance of Historical Buildings IV*. Vol. 2. WIT P, 1995, 63.

82 Betti and Vignoli. "Modelling and Analysis of a Romanesque Church under Earthquake Loading: Assessment of Seismic Resistance." 362.

83 Langenbach. "Learning from the Past: Traditional and Contemporary Unreinforced Masonry in Seismic Areas." 349.

3.4.3 Seismic Characteristics of Dry Stone and Multiple-Leaf Structures

Dry stone walls exhibit unique mechanical properties that differentiate them from mortared systems. Rather than relying on mortared joints to lend cohesion, dry stone structures gain stability and cohesion through the friction of the joint contact interfaces. As potential energy stored in the system is released, small movements occur until the structure equilibrates.⁸⁴ These energy releases occur slowly over time and can be independent of seismic events; however, seismic waves can intensify the process and cause a sudden collapse. Cohesion in a dry stone wall is greatly reduced by large, vertical accelerations during seismic activity and more greatly affects the friction level of the joint interfaces than horizontal accelerations.⁸⁵ This stick-slip action produced by either gravity or seismic waves may result in structural instability, deformation or collapse.

Results from large-scale testing of a single-wythe dry stone wall illustrates the cracking patterns and failure mechanisms associated with ground movements. Shaking table experiments used to simulate seismic waves show the general behavior of the test wall. Stepped flexural cracks form under cyclic loads with inelastic sliding of the stones along the bed joints, which can cause a rocking mechanism to occur or can lead to shear failure.⁸⁶

Multiple leaf dry stone constructions add to the structural complexity and produce a relatively unpredictable behavior when subjected to ground movement. Typical components include outer wythes (buted or bonded veneers), a rubble core and tying mechanisms of stone or other material (e.g., wood or metal). Seismic waves affect the system by producing out-of-plane movement—or bending of the wall—which tends to separate the veneer from the core. The level of damage depends, in part, on the effectiveness of the tying mechanisms

84 Meyer, Ochsendorf, Germaine, and Kausel. “The Impact of High-Frequency/Low-Energy Seismic Waves on Unreinforced Masonry.” 79.

85 Ibid.

86 Vasconcelos and Lourenco. “Evaluation of the In-Plane Seismic Performance of Stone Masonry Walls.” 3.

and pre-existing damage.⁸⁷ The critical element which enables historic masonry systems to survive earthquake loads is the tying mechanism. Connections between the various components provide greater stability in preventing displacement or collapse.

For multiple-leaf dry stone structures, proper tying mechanisms significantly increase stability during seismic events by aiding in energy dissipation. Typical tying components include timber or iron cramps or through stones (e.g., headers), which increased resistance to lateral loads. Conditions observed following seismic activity in Turkey indicate different levels of construction quality affect damage patterns. Because the tying mechanisms in multiple leaf walls increase stability, they have been identified in the field as being a critical component in a structure's ability to withstand ground movement.⁸⁸ High quality constructions—defined as stone systems containing regular stone courses laid in cement mortar with concrete tie beams—demonstrate a significantly higher resistance to ground motion than irregularly-shaped, random rubble structures constructed with low quality mortar and no tying element.⁸⁹

Though mortar increases binding properties and helps dissipate energy, dry stone systems require proper tying mechanisms to provide stability. Unlike dry masonry walls with no tying mechanism, dry walls which utilize timber beams or through stones endure much greater deformation before failing; without a tying element, the dry stone walls do not dissipate high enough levels of energy and can catastrophically fail.⁹⁰

87 M. Ramalho, A. Taliércio, A. Anzani, L. Binda, and E. Papa. "Experimental and Numerical Study of Multi-Leaf Masonry Walls." *Structural Studies, Repairs and Maintenance of Heritage Architecture*. Vol. IX. WIT P, 2005, 334.

88 Meyer, Ochsendorf, Germaine, and Kausel. "The Impact of High-Frequency/Low-Energy Seismic Waves on Unreinforced Masonry." 91.

89 Erdik. "The Earthquake Performance of Rural Stone Masonry Buildings in Turkey." 63-65.

90 Meyer, Ochsendorf, Germaine, and Kausel. "The Impact of High-Frequency/Low-Energy Seismic Waves on Unreinforced Masonry." 90.

Other influential characteristics affecting seismic behavior of multiple leaf systems involves the rubble fill material and its interaction with the veneer. Many systems display a unique behavior due to the loose sand, gravel or stone rubble compacted within the core. When subjected to high-frequency vibrations, the core material can densify and fluidify, which increases the lateral thrust on the outer leaves and may ultimately lead to deformation or collapse.⁹¹ Additionally, because a common failure mechanism in dry stone structures includes overturning, the friction angle of stone blocks or rubble fill can increase or decrease the structure's stability. Less lateral pressure is applied to the outer leaves when the friction angle⁹² of the fill increases.⁹³

3.4.4 Analyzing and Diagnosing Damage from Past Events

Even with knowledge of certain properties exhibited by stone structures, an element of unpredictable behavior remains during seismic events. Analyzing and classifying damage after a seismic event increases knowledge of behavioral patterns in masonry systems. Several studies have documented conditions resulting from earthquake damage and have made correlations between intensity of the event and resultant damage. Non-destructive testing has also been employed to predict behavior by assessing existing conditions, such as crack patterns.

In-field analysis of failed and damaged systems has provided insight into the vulnerabilities of certain structures and identified architectural elements most susceptible

91 Ibid., 79.

92 The friction angle in dry stone systems is the angle of inclination of the joints. In general, a friction angle above 20° provides added stability to structures. Joints with an incline of less than 20° fail by overturning more easily. See Powrie, W., R. M. Harkness, X. Zhang, and D. I. Bush. "Deformation and Failure Modes of Drystone Retaining Walls." *Geotechnique*. 52:6, 2002, 435-446.

93 Meyer, Ochsendorf, Germaine, and Kausel. "The Impact of High-Frequency/Low-Energy Seismic Waves on Unreinforced Masonry." 84.

to damage. Common damage observed in many masonry structures includes vertical and stepped cracks and open joints. Vertical fractures generally occur around large openings – particularly windows, doors and arches.⁹⁴ Diagonal stepped cracks form in dry stone and mortared masonry systems and result from inelastic sliding (displacement caused by shear stress).⁹⁵ This cracking pattern corresponds with horizontal loads, which cause the linear deformation.



Figure 17. Vertical crack produced by seismic action. *From* www.conservationtech.com

94 El Samny. “Structural Response during the 1992 Cairo Earthquake.” 794.

95 Vasconcelos and Lourenco. “Evaluation of the In-Plane Seismic Performance of Stone Masonry Walls.” 3.

Though shear stress generally emerges as diagonal stepped cracks, shear failure can also occur from differential stiffness within walls, which results from varying rigidity of connections and the strength of lintels.⁹⁶ These differences in rigidity or connection strength produce diagonal cracks – though not necessarily stepped cracks. Other structural failures are specific to certain construction methods. Lateral loads applied to multiple leaf masonry systems emphasize any structural deficiencies. As previously mentioned, when not properly tied, the wall can separate or collapse with horizontal – and even vertical – forces. These out-of-plane bending failures typically occur in brittle systems under horizontal forces. However, all buildings are subject to partial or full collapse due to inadequate connections or anchoring. Wall deformation or separation generally occurs in corners of poorly connected load-bearing structures.



Figure 18. Failed corner of a multiple leaf system. *From www.world-housing.net.*

⁹⁶ Binda, Cardani, Penazzi and Saisi. “Performance of Some Repair and Strengthening Techniques Applied to Historical Stone Masonries in Seismic Areas.” 1200.

Roofing systems can also heavily influence behavior during seismic events. Both poor connection of roof and walls and thrust of the roof can lead to failure. Roof failure occurs from inadequate connection of the supporting walls. Inadequate connection of walls and roof can also lead to additional thrust on the walls and cause out-of-plane failure.⁹⁷ Non-structural architectural elements are also susceptible to damage from out-of-plane mechanisms. The seismic effects on walls—especially cracking—can detrimentally affect parapets, cornices and spandrels and result in severe cracking or localized or total collapse of the elements.

Establishing correlations between damage types and seismic events requires prior knowledge of each structure's initial conditions. Records of the fabric prior to an earthquake eliminates false correlations, since similar damage may occur from unrelated events, such as differential settlement or general neglect. The possible effects of differential settlement—including large-scale cracking and tilting—resemble products of seismic activity. Without records of preexisting conditions, assumptions must be made based on other evidence. Buildings constructed on solid bedrock allow for more accurate interpretation; if fractures extend through the building and bedrock, the condition likely results from seismic activity.⁹⁸

Understanding conditions due to prior damage coupled with knowledge of existing fabric offers an indication of seismic performance. However, sites with an extensive history or unique circumstances (whether past or present, such as burial or neglect), present some complexity in using past and existing conditions to predict seismic behavior. For instance, when analyzing seismic damage at archaeological sites, other factors are

⁹⁷ Ibid.

⁹⁸ Marco. "Recognition of Earthquake-Related Damage in Archaeological Sites: Examples from the Dead Sea Fault Zone." 152.

considered to determine whether damage occurred from a seismic event or from general aging. Geological evidence of past earthquakes, burial of biological elements (such as plants, animals or humans), historical records from texts or images and complete destruction of settlements can indicate catastrophic seismic events with related structural damage.⁹⁹

Failure occurs not only from large-scale structural flaws or inconsistencies but also from problematic design of or changes in smaller details. Investigations of a building's connections, existing conditions and load patterns reveal the defects which produce failure during seismic events. Existing conditions inform changes in load distribution or failure modes; cracks can indicate areas of weakness, which may not have existed previously, and are evidence of crucial structural changes. Identifying certain characteristics in a structure—geometries, construction techniques and physical, chemical and mechanical properties of materials—is required to ascertain those critical failure mechanisms.¹⁰⁰

Field studies of historic structures prior to seismic events have been established as a method of preventive action. After diagnosing and understanding parameters established to quantify damage potential, buildings are categorized by vulnerability. Assessments rank vulnerability based on a historic structure's relation to building codes, such as Eurocode 8¹⁰¹, in order to define a standard safety factor. Data collection regarding in-plan area, area to weight, number of stories, regularity of plan and length of walls and openings informs the vulnerability level and determines the safety factor.^{102, 103} These factors—or indices—offer

99 Ibid., 153.

100 Binda, Saisi, and Tiraboschi. "Investigation Procedures for the Diagnosis of Historic Masonries." 202

101 Eurocodes were developed to standardize European building code. Eurocode 8 pertains to the design of seismic resistance in new and historic structures. More information is available at <http://www.eurocodes.co.uk/EurocodeDetail.aspx?Eurocode=8>.

102 Erberik. "Generation of Fragility Curves for Turkish Masonry Buildings Considering In-Plane Failure Modes."

103 Lourenco and Roque. "Simplified Indexes for the Seismic Vulnerability of Ancient Masonry Buildings."

a low-cost prediction method to understand which buildings are susceptible to failure during a seismic event. Understanding possible failure mechanisms prior to an earthquake enables engineers to identify weaknesses and correct poor connections or implement larger strengthening programs; these assessments are sometimes augmented by computer-generated modeling software to project vulnerabilities and further understand seismic behavior.

3.4.5 Discrete Element and Finite Element Methods of Modeling Historic Structures under Seismic Loads

General Application to Masonry Structures

Numerical methods for computing movements and the behavior of masonry structures emerged after Peter Cundall's 1971 development of a discrete element method (DEM) of monitoring the contact and motion of grains. This method of understanding grain interaction was later applied to larger structures, such as masonry columns, and modeled using computer simulations to understand movement when subjected to seismic activity. Advancements in technology during the past decade have enabled engineers to construct complex computer-generated models, which simulate seismic conditions and predict the behavior of entire buildings during an event of a certain magnitude. Due to the unpredictable nature of earthquakes, the system is based on controlled conditions, such as wave type and magnitude. Many of these inputs relate to actual conditions observed and recorded from past events.

Anticipating seismic behavior offers two advantages: one corresponds to preventive conservation, which would allow conservators to anticipate possible damage and strengthen structural systems. The other advantage stems from unnecessary seismic strengthening,

which in itself can be damaging to historic structures. Many strengthening programs alter performance and fabric; past seismic activity has proven some reinforcement methods to be unnecessary or inadequate. The development of discrete and finite element modeling enables conservation engineers to simulate seismic strengthening of computer-generated models to determine changes in or improvement of behavior during ground movement.

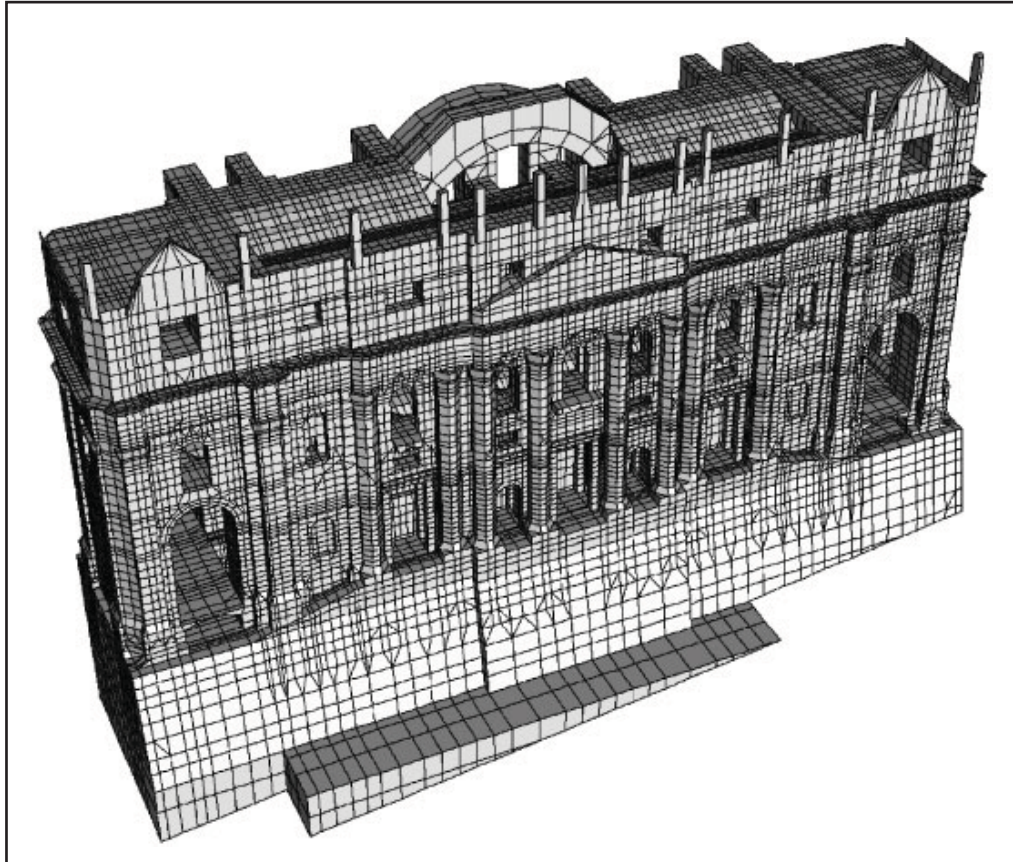

Figure 19. Application of FE mesh to a historic structure. *From Lourenco, 2002.*

The modeling process requires certain known characteristics of the masonry structure before simulation. When considering basic forms of construction (single-wythe walls with no ornate ornamentation or existing conditions), an accurate model can be generated by applying a finite element (FE) mesh. The FE analysis is generated from inputs representing the geometries, materials, loading and boundary conditions of the wall

construction.¹⁰⁴ The accuracy depends not only on the ability to properly represent the material and conditions but also on grid density. Because of the complexities in even basic structures (e.g. presence of joints, variations in block sizes, heterogeneity of the material, etc.), some simplification occurs in each simulation. However, inaccuracies develop from poor data inputs—usually a condition of variations in wall width, unknown load distributions or intersections, use of composite materials and complicated geometries.

Using a linear analysis, the shear and friction failure modes can be modeled at the macro level to show overall structural movement. Ainsworth et al. generated a series of models to demonstrate linear failures in a simple dry stone construction.¹⁰⁵ A 1.00 meter square test wall (with a thickness of 0.20 meters) was clamped on a horizontal rigid surface; with uniform in-plane vertical and horizontal forces applied to the top of the wall surface, the model yielded a tensile failure.¹⁰⁶ The failure occurred as diagonal stepped

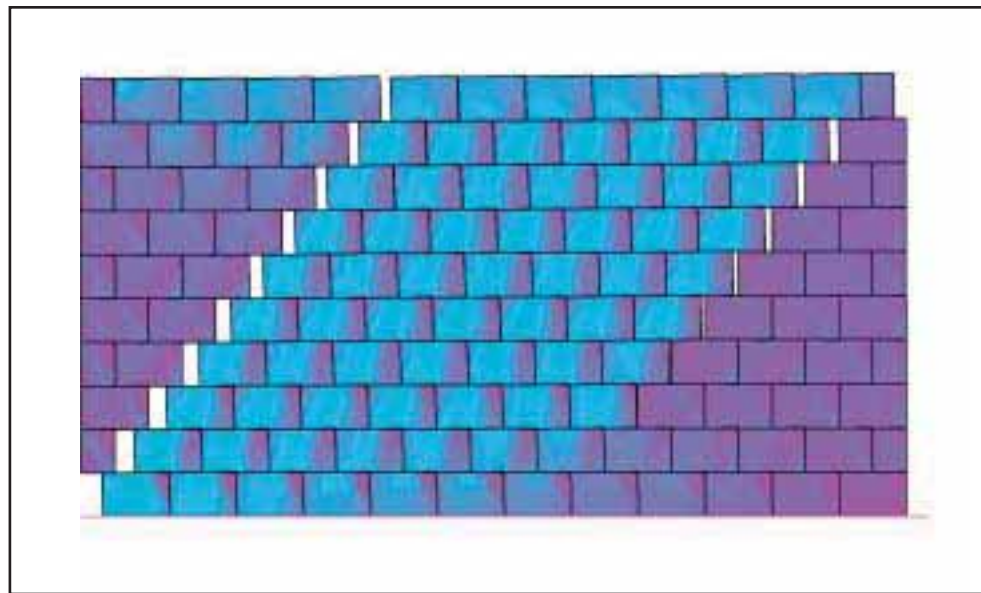

Figure 20. FE model showing shear failure in a dry stone wall. *From Ainsworth et al., 2008.*

104 Stavros K. Kourkoulis. *Fracture and Failure of Natural Building Stones*. New York: Springer, 2006, 158.

105 Ainsworth and Mihai. "An Adaptive Multi-Scale Approach to the Modelling of Masonry Structures."

106 Ibid.

cracks—typical of dry stone walls. This commonly used macro model, which predicts the broad structural movements of the entire object, does not illustrate small-scale behavior of the individual components.

In order to increase the accuracy of predicted behavior, Ainsworth et al. created a multi-scale approach, which combines overall structural movement and individual behavior of the stone units. The multi-scale approach better represents stress distributions and apparent dislocations, because the mesoscopic (or micro-structural) scale identifies movement, such as cracking and displacements, in the joint interfaces.¹⁰⁷ Though unrealistic to model an entire structure unit by unit, mesoscopic behavior of a limited sample area can be applied to the larger structure; additionally, the micro-scale approach can detect aberrations found in localized areas and which require small-scale analysis.

The combined macro/micro modeling systems utilize a homogeneous structure to understand displacement during seismic activity. Though this type of model generally applies to dry stone structures, mortared constructions contain different materials, each with distinct properties. The interaction of the differing materials is not always known, and as a result, can only be generalized through FEM modeling. Several methods for determining behavior were developed to account for the mortar/stone interaction.

The development of micro analysis has enhanced the capabilities of modeling composite systems by allowing simulations to individually model the component materials. By modeling each unit, mortar face and interface separately enables methods limited to homogeneous constructions to predict behavior of composite systems when combining the results of each component. However, limitations exist in the practicality and accuracy of this method due to the difficulty in understanding wall geometries (especially of the mortar

¹⁰⁷ Ibid.

component).¹⁰⁸

Another adaptation for composite systems includes modeling the system jointly by disregarding the mortar component. This option provides a fair degree of accuracy, since the properties provided by the mortar cannot be wholly known and only estimated; even when models individually simulate mortar, the unknown geometries of the material within the system produces imprecise results.

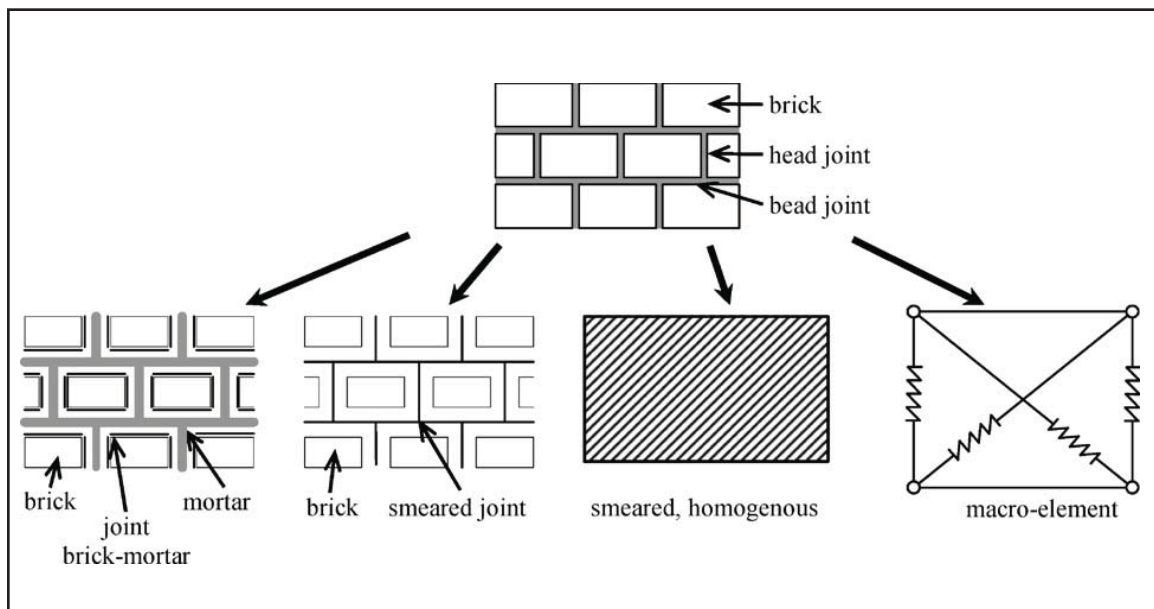

Illustration 3. Illustration of different modeling techniques for mortared systems. From Mistler et al., 2006.

Application of DEM/FEM Analysis to Historic Stone Structures

Though more sophisticated modeling techniques have emerged in the past few years, models of historic structures require a more simplistic design to simulate behavior due to the restrictive size of most buildings. The amount of information needed for and received from simulation when using the intensive micro-scale approach is currently too excessive for large-scale structures. To compensate for the excess of information, simplifications in

108 Mistler, Butenweg, and Meskouris. "Modelling Methods of Historic Masonry Buildings under Seismic Excitation." 500-1.

geometries are required to reduce the output while still achieving valid data.

When analyzing the accuracy of results generated by FE models, test walls were constructed and seismic waves simulated by a shaking table or other means.¹⁰⁹ The same test methods were employed to confirm the accuracy of FEM results when applied to historic structures. Large-scale tests conducted in conjunction with FE models enabled researchers to establish correlations between real movement and modeled movement.

Simple ashlar wall constructions, arches and columns have been built and modeled to understand the relationship between numerically predicted and actual behavior. The tests indicate that the simple dry stone wall constructions and arch systems have very predictable failure mechanism when subjected to rocking and harmonic shaking; these large-scale experiments were accurately modeled using a DEM/FEM analysis.¹¹⁰ However, freestanding columns contain more complicated geometries and are more susceptible to changes in performance due to slight variations in inputs (including geometry, structural properties or force from seismic load).¹¹¹

Many studies have been conducted to investigate the seismic performance of ancient Greek columns at the Parthenon. The results of these studies have contributed to both the understanding of column behavior and the limitations of numerical modeling. Though the numerical models accurately represent the types of possible failure mechanisms (produced by rocking and sliding), too much variability exists to correlate peak ground acceleration

109 Pagnoni et al. created a comparative test to determine the accuracy of DEM models. Shaking table tests were used to simulate ground motion to record the behavior of an 8-block arch structure. The arch was then modeled with DEM and subjected to the same harmonic ground motion. The test concluded that DEM has the capacity to accurately represent the failure mode in the simple arch construction. See Pagnoni, "Seismic Analysis of Masonry and Block Structures with the Discrete Element Method." 1673.

110 Pagnoni, "Seismic Analysis of Masonry and Block Structures with the Discrete Element Method." 1674.

111 Psycharis. "Numerical Study of the Seismic Behaviour of a Part of the Parthenon Pronaos." 2083.

with collapse.¹¹² Psycharis et al. analyzed the response of a simplified classical column subjected to seismic events of varying magnitudes. The study demonstrated changes in behavior due to different seismic inputs. Typical behavior (under certain earthquake inputs) involves displacements and rotation of the lower joints due to rocking with the upper blocks moving as a single unit;¹¹³ The highly non-linear nature of movement infers that response varies greatly with differing force. Changing the earthquake input shows an altered behavior where sliding occurs at the top of the column rather than at the base.¹¹⁴

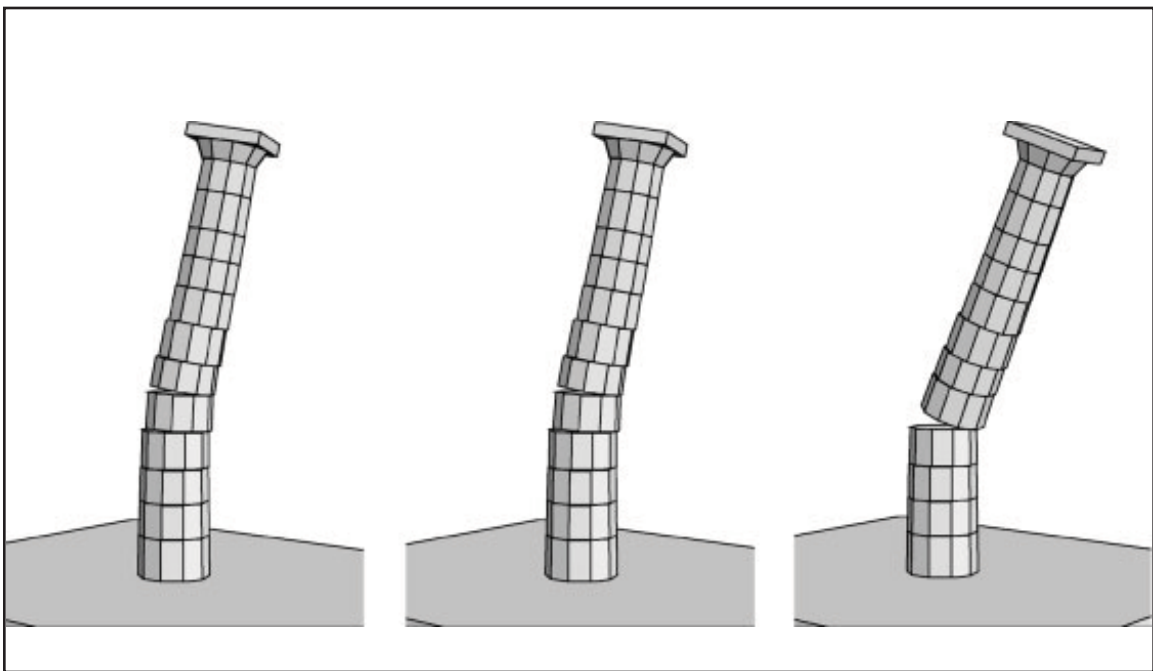

Figure 21. Simulation of column showing failure at the base. From Psycharis et al., 2003.

112 Ibid. Other studies show strong correlations between load capacity and failure. The response of columns to seismic waves is highly non-linear and, therefore, much less predictable than linear failures in walls and larger structures. Columns subjected to ground vibration experience rocking and sliding (i.e. a dynamic response) difficult to accurately model with FE analysis. See also Demonstenous, M. and G. C. Manos. "Dynamic Response of Models Subjected to Horizontal Motions." *Structural Preservation of the Architectural Heritage*. Proc. of IABSE Symposium Rome. Vol. 70. Italy: IABSE, 1993. 361-368 and Mouzakis, H.P., I.N. Psycharis, D.Y. Papastamatiou, P.G. Carydis, C. Papantonopoulos, and C. Zambas. "Experimental Investigation of the Earthquake Response of a Model of a Marble Classical Column." *Earthquake Engineering and Structural Dynamics* 31 (2002): 1681-698.

113 Psycharis. "Numerical Study of the Seismic Behaviour of a Part of the Parthenon Pronaos." 2075.

114 Ibid., 2074.

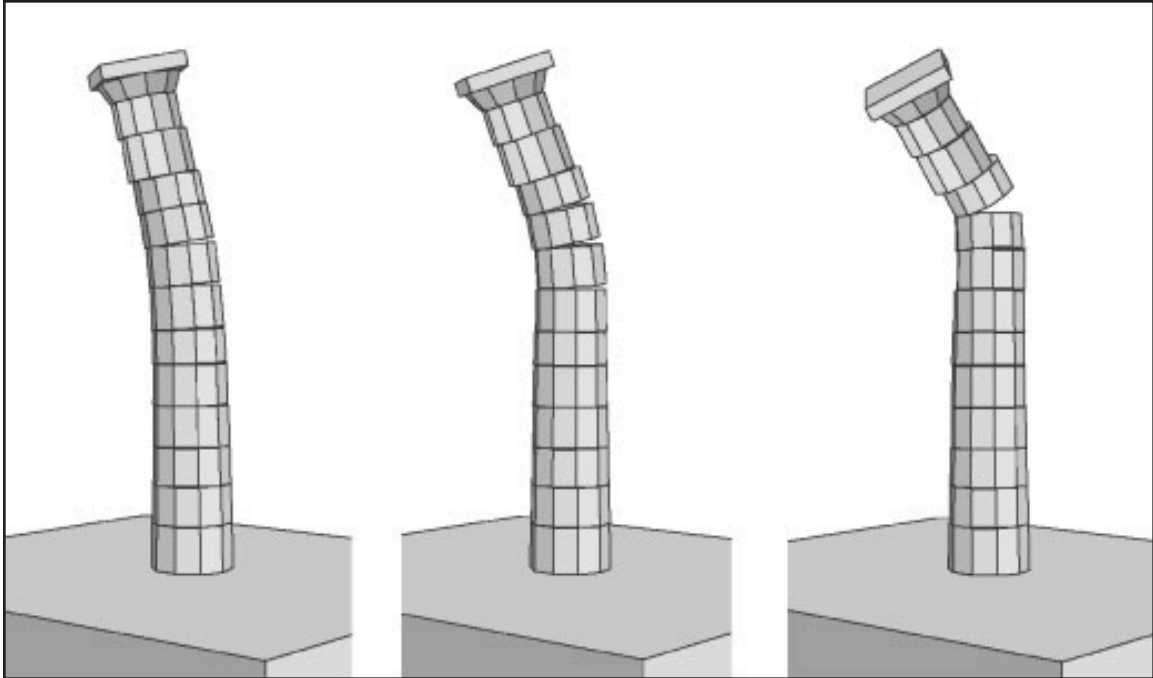

Figure 22. Failure in the upper blocks of the column due to eccentric waves. *From Psycharis et al., 2003.*

More important to understanding the behavior of historic structures is the difference in response due to weathered surfaces and existing conditions. Models represent these conditions through simplifications, such as reducing joint interface by rounding corners or splitting blocks into multiple units to characterize cracks.¹¹⁵ These simplifications account for the basic deterioration of masonry units, but cannot accurately represent the weathering patterns caused by innumerable mechanisms during years of exposure to environmental conditions. However, simplifying weathered surfaces does largely affect the failure mode in seismic simulations and better approximates where failure will occur. Lowered joint interface reduces the necessary friction required to minimize sliding; simulations replicate joints displaying conditions from loss or cracks and demonstrate the resultant structural failure.¹¹⁶

115 J.V. Lemos. "Modeling Stone Masonry Dynamics with 3DEC." Ed. Heinz Konietzky. *Numerical Modeling of Discrete Materials in Geotechnical Engineering, Civil Engineering, & Earth Sciences*. Dallas: Taylor & Francis, 2004, 10.

116 Psycharis. "Numerical Study of the Seismic Behaviour of a Part of the Parthenon Pronaos." 2077.

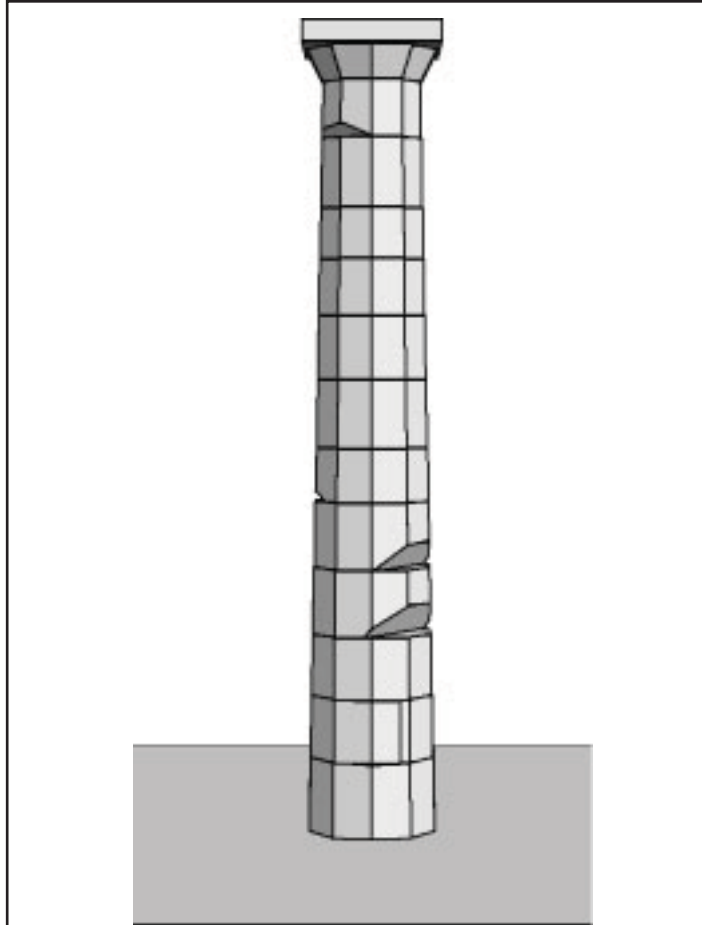

Figure 23. Column modeled with existing conditions. *From Psycharis et al., 2003.*

When applied to historic building systems, simplifications of weathering patterns and existing conditions pose multiple complexities but still allow for the rendering of generalized failure mechanisms. Producing a historic model requires several inputs: geometry of internal and external elements, construction (including tying mechanisms), core material (if present), crack patterns and other existing conditions. This initial state requires intensive assessment and is difficult to accurately represent due to the many unknown conditions of historic masonry systems. Many load patterns have shifted since their initial construction; structural beams do not always carry the apparent load. Loads tend to shift to exterior walls, which cannot be easily detected—but greatly impact the structure’s seismic behavior.

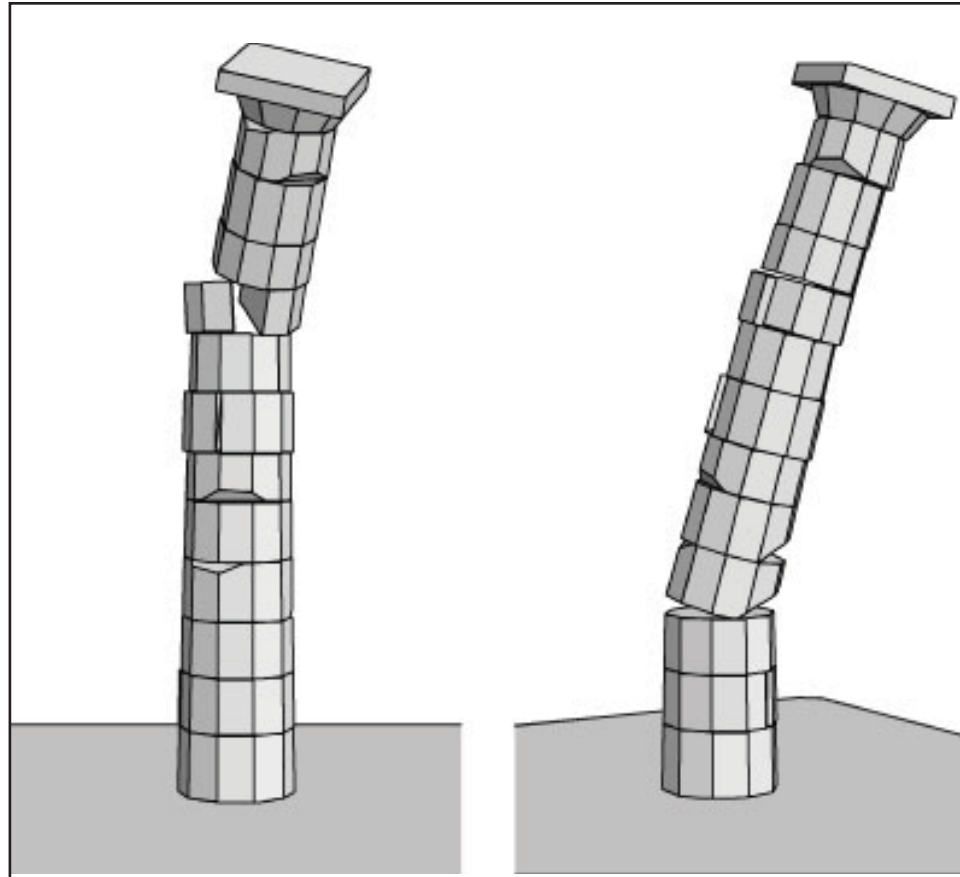

Figure 24. Changes in failure due to existing conditions. *From Psycharis et al., 2003.*

Understanding geometries presents a further challenge, since original construction methods may not be known. In-field observations have proven the importance of tying mechanisms (particularly in multiple leaf constructions), so knowledge of the structural system and the component connections increases the accuracy of historic models. Improperly tied systems provide significant points of weakness in buildings, which subsequently leads to failure at those intersections; strength of these connections is necessary prior to generating models.¹¹⁷

As mentioned previously, modeled simulations largely rely on homogeneous systems to predict material behavior, which can be problematic in historic structures. Many historic

¹¹⁷ Binda. "Performance of Some Repair and Strengthening Techniques Applied to Historical Stone Masonries in Seismic Areas." 1200.

structures contain numerous materials, sometimes resulting from multiple additions. One method to account for varying construction periods and materials requires modeling individual sections of a building. Simplifying each section (by homogenizing the materials) allows a more accurate system to be modeled; each modeled component can then be synthesized into a single structure to identify overall movement of the building.

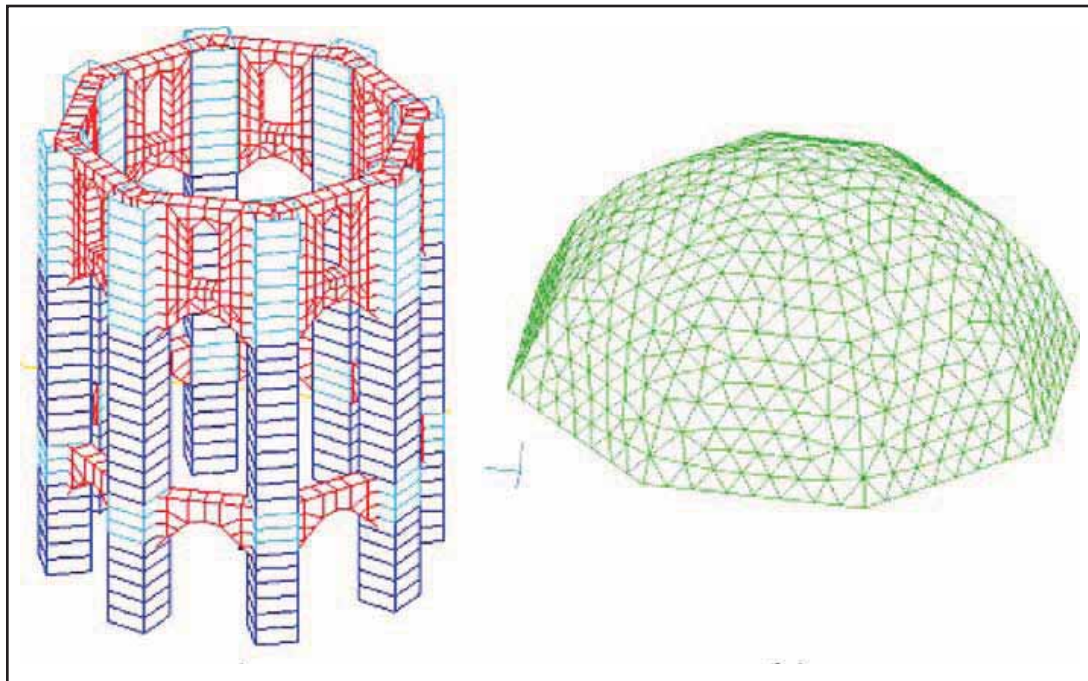

Figure 25. Individual meshes applied to building components of the Aachen Cathedral, Germany. From Mistler et al., 2006.

Even without precise data relating to construction, general failure mechanisms emerge and provide an awareness of the building's structural strengths and weakness. This data enables engineers to adjust the inputs—seismic load, material, structural load, etc.—to experiment with a building subjected to various conditions. For historic buildings that exhibit failure mechanisms resulting from poor construction, deteriorated structural materials or emerging conditions, models can simulate the effects of seismic strengthening techniques, which greatly alter seismic response.



Figure 26. The complete mesh of the Aachen Cathedral, Germany. From *Mistler et al.*, 2006.

3.4.6 Effects of Strengthening on Historic Masonry under Seismic Loading

Traditional strengthening measures were implemented to establish as rigid a structure as possible. When considering strengthening options for historic constructions, engineers targeted weaknesses related to the structures' inability to resist horizontal forces, which cause out-of-plane bending and collapse. As a result, strengthening options attempted to increase rigidity by creating a monolithic structure—one that performs more as a modern reinforced building able to resist lateral loads. The extent to which a historic structure morphed into the highly rigid modern ideal determined the success of the intervention. Little concern was given to material compatibility, and performance during seismic events remained relatively unpredictable.

Seismic retrofitting programs generally entailed large-scale replacement of components, such as wooden floors or roofing structures. Without properly understanding the alterations in performance characteristics, engineers sought to morph historic structures into constructions that more closely imitated concrete.¹¹⁸ Reinforced concrete slabs served as replacement material for floors to strengthen the connection between walls. Grout injections filled voids and stiffened dry stone or rubble construction. Jacketing was also introduced into some buildings with multiple leaf systems; the addition of steel meshes increases wall thickness and attempts to improve resistance to horizontal loads by providing a more rigid connection.

Each strengthening program greatly impacts a historic structure's performance during seismic events by increasing rigidity; however, the overall effect of strengthening may introduce material compatibility issues or new failure modes—rigidity does not ensure seismic resistance. Large-scale experiments investigating the efficacy of reinforced concrete replacement floors found that the technique does increase performance in historic structures but is unnecessarily destructive; the same result can be attained using steel ties at floor level as a means to resist horizontal force.¹¹⁹

Grout injection techniques strengthen rubble and dry stone systems by introducing grout into the voids to allow for more cohesion (and a reduction in brittleness) and to enhance the damping properties of the structure. The technique presents risks to the structure with the possibility of creating hydrostatic pressure within the system during injection, causing slight displacements in stone interfaces or trapping air in voids or cracks. Other issues occur from poor application or lack of knowledge of the system; grouting

118 Ibid., 1196.

119 Miha Tomazevic. "Laboratory and In Situ Tests of the Efficacy of Grouting and Tying of Stone Masonry Walls." *International Workshop CNR-GNDT. Proc. of Effectiveness of Injection Techniques for Retrofitting of Stone and Brick Masonry Walls in Seismic Areas*, Milan, Italy. Ed. L. Binda, 115.

rubble and dry structures requires an understanding of the size distribution of voids in order to estimate the success of bonding the internal structural components.

Though jacketing enhances earthquake resistance in historic structures, it usually results in insensitive alterations to achieve rigidity. Jacketing applies mainly to multiple leaf constructions to increase connection between leaves. Reinforcing nets attached to each wall face provide additional support when tied with steel connectors. The nets are then covered with a render. Most wall failures which occur after jacketing generally relate to poor connections of the jacketed walls and poor durability of the steel covers, which are susceptible to corrosion (particularly in buildings with moist walls).

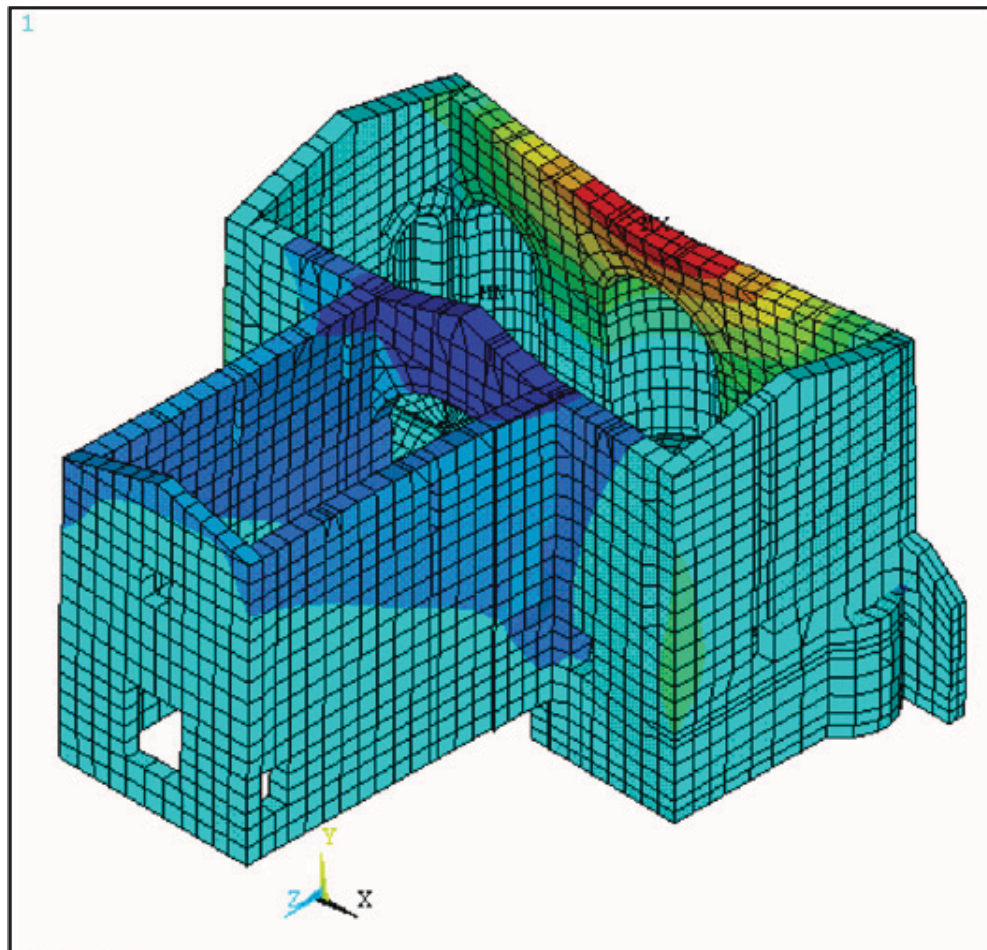

Figure 27. Analysis of out-of-plane bending, Farneta Abbey, Italy. *From Betti et al., 2008.*

Due to the extent of failed or unnecessary strengthening programs, FEM analysis offers a nondestructive approach to predicting behavior of seismically strengthened structures. FE analyses of seismic strengthening programs have the same limitations as modeled historic structures (due to unknown constructions, connections, load distributions, etc.); however, the general behavior of the historic model informs the inputs of the strengthening system. The failure mechanisms of the Farneta Abbey appear as out-of-plane bending, which results from its inability to resist horizontal loads.¹²⁰ Understanding

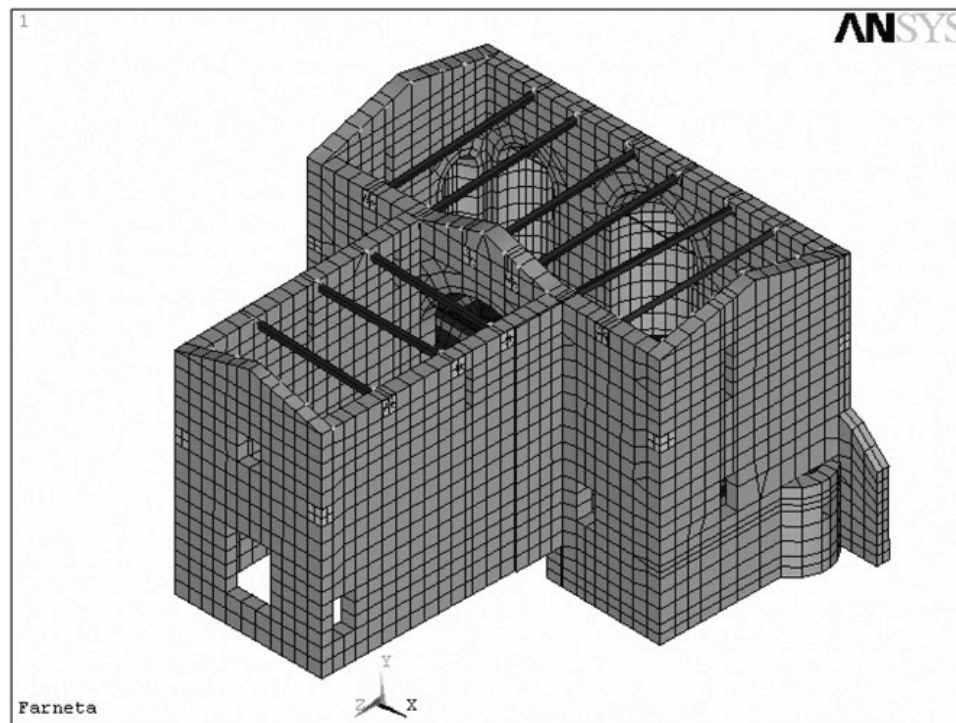

Figure 28. Model showing changes in behavior resulting from possible seismic strengthening options. *From Betti et al., 2008.*

the failure mechanisms illustrated through FE analysis enables engineers to strengthen connections, walls or roofing systems by employing the least invasive intervention. Though the lack of connection in the orthogonal walls and major cracking contribute to the Farneta Abbey's failure modes, models of various strengthening programs indicate that the

¹²⁰ Betti and Vignoli. "Modelling and Analysis of a Romanesque Church under Earthquake Loading: Assessment of Seismic Resistance." 361.

destructive reinforcement systems (such floor replacement or jacketing to stiffen walls and close major cracks) are excessive. Modeling changes in behavior resulting from retrofitting options demonstrates the effectiveness provided by the less invasive horizontal steel tie beams.¹²¹

3.4.7 Conclusion

The limitations in accuracy of computer-generated simulations (and in-field analyses) creates a need for more complete data in order to predict behavior of historic stone structures. This need is amplified by the poor results from past seismic strengthening programs—ones that either failed regardless of intervention or caused irreversible damage due to material incompatibility. Nondestructive testing of connections, load patterns and materials would greatly reduce the unknown properties and constructions in historic systems. Nondestructive testing methods—such as thermography, sonic, radar, X-ray, flat-jack, hardness, penetration and pull-out tests—can supply information on voids within the system, load distributions, connective components and basic internal construction techniques. The benefit of revealing those undefined factors that have been typically associated with failure during seismic events is the pronounced increase in accuracy when predicting behavior and formulating intervention strategies. Eliminating unknown factors within historic structures improves the ability to prevent future catastrophic failure.

121 *Ibid.*, 365.

4.0 DRY STONE WALLS

4.1 Literature Review

4.1.1 Introduction

The literature reviewed for this research incorporates publications by both conservation professionals and engineers and mainly dates from 1986-2009. The earliest publications examine known properties of dry stone structures and draw conclusions from recorded observations; the understanding of dry wall dynamics also developed from a mid-nineteenth century experiment conducted by Sir John Burgoyne of the Corps of Royal Engineers, which assessed failure in retaining walls. Engineering studies in the early- to mid-1990s further developed Burgoyne's 1834 assessment, while conservators implemented monitoring programs at dry stone archaeological sites to record movement. Most of these studies have been published in Western European journals relating to engineering geology and archaeological conservation. Additional literature was obtained from engineering conference proceedings.

Though little literature exists on dry stone masonry conservation, a renewed interest in reintroducing the ubiquitous Western European dry stone retaining wall as a common construction technique for property dividers and highway borders has led to a series of research efforts among engineers. While the research is based on identifying the

factor of safety—determined by load and compressive and shear strength—the results have an effect on diagnosing and understanding historic dry stone structures.

A review of literature concerning dry stone masonry indicates that only within the past eight years has there been significant interest in large-scale testing as a means of quantifying properties and predicting failure. These tests mainly apply to the future construction of retaining walls modeled after the ubiquitous type found throughout Western Europe, and are limited in their application to historic structures.

4.1.2 Review of Past Research and Current Literature

Nineteenth Century British Corps of Royal Engineers Program

The first experiment performed on a full-scale dry stone masonry test wall was conducted in 1834 by British Lieutenant General Sir John Burgoyne as part of the Corps of Engineers research.¹²² Burgoyne acknowledged previous work that attempted to calculate dimensions needed to construct stable walls, but his was the first to empirically determine factors contributing to failure through a trial and error process. Burgoyne built four test walls on rock foundations—all of equal height and mass and all exposed to the same external environment—to understand the relationship between wall design/height and earth backfill. Burgoyne conducted the experiment to further the understanding of failure mechanisms, such as overturning.

Burgoyne’s methodology included four walls with slight variations in design. The test walls included a vertical wall, one with a battered face and vertical back, one with a

122 Sir John Burgoyne. “Revetments or Retaining Walls.” *Papers on subjects connected with the duties of the Corps of Royal Engineers*. 3rd ed. Vol. 3. London: Royal Corps of Engineers, 1853. 154-59. *Hathi Trust Digital Library*. 20 Jan. 2009 <<http://hdl.handle.net/2027/wu.89073369290>>. The paper was published as part of the Corps of Royal Engineers collected work for the year 1853; however, Burgoyne’s experiment was conducted in 1834.

vertical face and battered back and a wall angled several degrees on both faces to exert pressure against the soil backfill. The 20' high walls were not tied at the ends and were constructed on a rigid base. Built in phases, soil backfill was incrementally added until the wall reached the full height of 20', unless failure occurred prior to completion. The experiment examined the amount of pressure tolerated by walls of different design and concluded that the angled wall and wall with the battered outer face tolerated the most pressure exerted by the soil backfill. The other two walls failed before achieving full height.¹²³

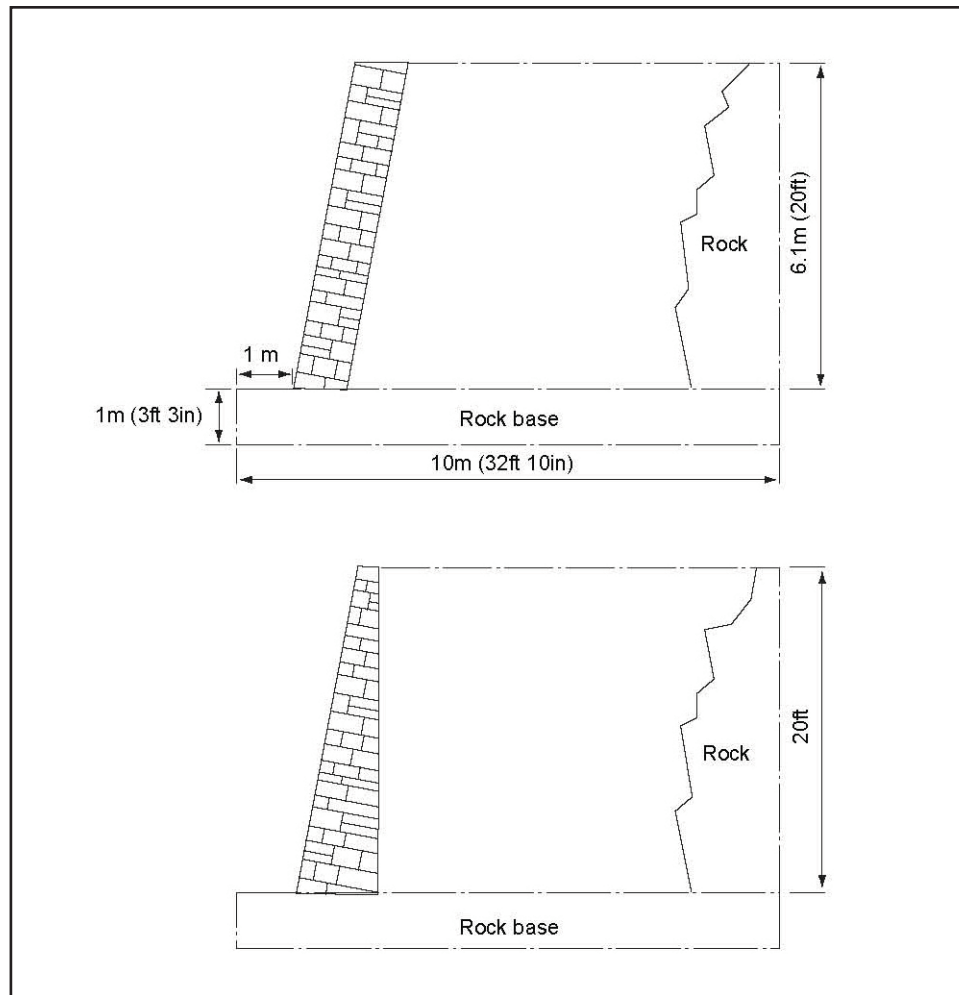

Illustration 4. Burgoyne's test walls with incline and outer batter. *From Brady et al., 2002.*

¹²³ *Ibid.*, 159.

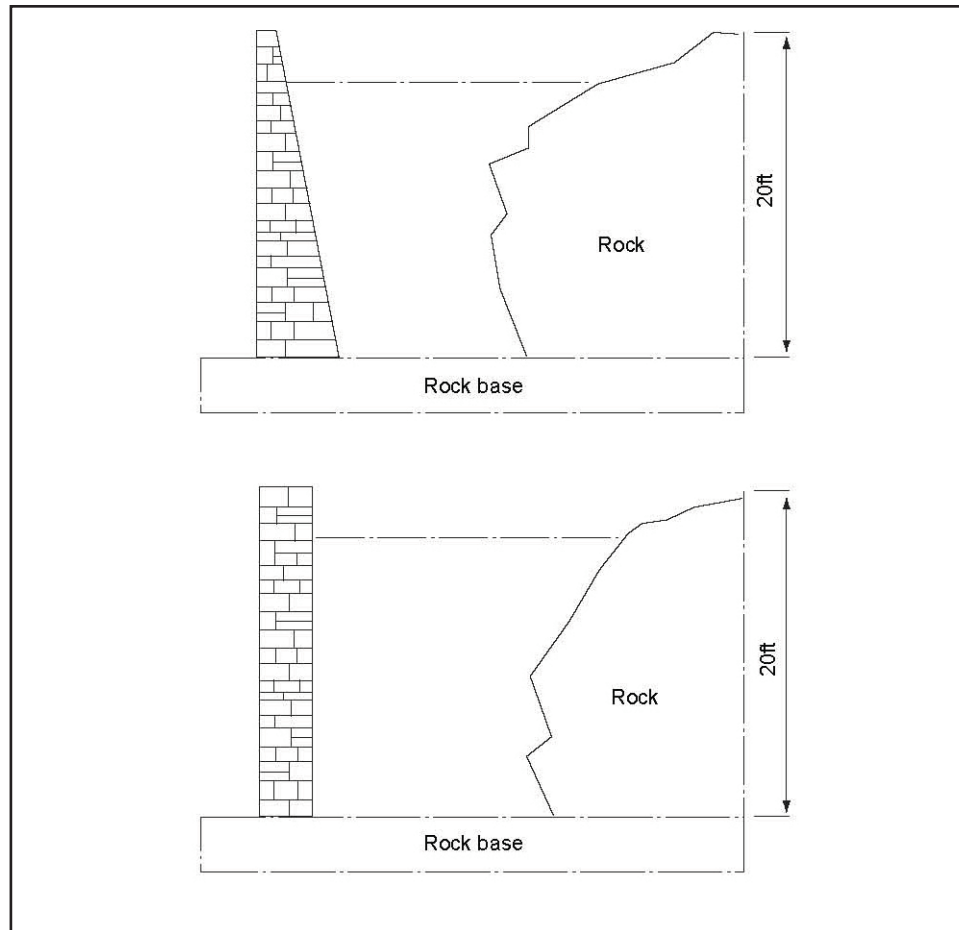

Illustration 5. Burgoyne's test walls with inner batter and vertical face. *From Brady et al., 2002.*

The test remained the only full-scale experiment attempted on dry stone walls for more than one hundred years. Though it analyzed and determined design strength, the test was limited in scope. Burgoyne acknowledged the “green” period associated with dry stone construction. During the first year dry stone structures show significant settlement until they reach their maximum stability. Because Burgoyne's test only lasted for several months after the initial construction phase, the walls would not have achieved full stability. Additionally, individual properties of stone and soil type (which also impact wall stability) were not analyzed. These limitations have been further researched and results have been published in more recent literature.

Problems resulting from the aging process in Western European dry stone retaining walls prompted conservators and engineers to focus on efforts to stabilize bulges and prevent toppling. Many of these walls had been constructed during the nineteenth and early twentieth centuries and lined hundreds of miles of highway.¹²⁴ Failure of the masonry walls presented safety issues, so intervention to stabilize the structures was necessary.

Literature on field studies of dry stone walls in the United Kingdom emerged during the late 1980s and early 1990s as a means to assess condition and function.^{125,126} Construction of new walls preceded the surveys of failed retaining walls and, consequently, the understanding of failure modes. In response to the lack of contemporary research, Osmond created a database of failed walls throughout the United Kingdom for the Building Research Establishment.¹²⁷ This survey underscored the need for understanding dry stone wall properties and attempted to characterize failure mechanisms based on previous knowledge and observations. Successive research utilized similar parameters that attempted to characterize dry stone properties and included some direct application to the conservation field—though these publications largely remained in the engineering realm.

In 1986 Cooper commenced a series of engineering-based studies that would follow his initial investigation of failure modes found in Western European retaining walls.¹²⁸ Later authors, such as Delgado Rodrigues, attribute failure to weathering, which can result in

124 W. Powrie, R. M. Harkness, X. Zhang, and D. I. Bush. "Deformation and Failure Modes of Drystone Retaining Walls." *Geotechnique*, 52:6, 2002, 435.

125 M.R. Cooper. "Deflections and Failure Modes in Dry-Stone Retaining Walls." *Ground Engineering*, 19:8, 1986, 28-33.

126 S. Osmond. "A Survey of Failed Free-Standing Walls." *Proceedings of the Third International Masonry Conference*. 6th ed. Vol. 3rd Proc. British Masonry Society, 1994. 87-90.

127 *Ibid.*

128 Cooper. "Deflections and Failure Modes in Dry-Stone Retaining Walls." *Ground Engineering*, 19:8, 1986, 28-33.

toppling or bulging.¹²⁹ As one of the earliest conservation publications related to dry stone conservation, Delgado Rodrigues offers some information on remediation. However, the greatest significance gained from these publications relates to weathering and establishing properties of historic dry laid structures, which is most applicable to the conservation field. Weathering still presents a challenge to conservators and engineers and, even with the introduction of modern technology to quantify data, continues to place limitations on testing results.

Early literature provided information on causes of failure and was used specifically for diagnosing existing problems and implementing treatment plans. Literature specified for the conservation field conflict in intervention techniques to stabilize structures. However, these early conservation studies unanimously recognized the importance of material compatibility and rejected the use of Portland cement as a binding agent to improve load distribution. Typical application was superficial (so it could not relieve points of stress) and offered little additional cohesion.¹³⁰

However, conflict arose in various intervention techniques. Some interventions valued function/stability/safety over fabric, while other noninvasive techniques placed significance on existing fabric. Invasive interventions (which cause various degrees of material loss) require pinning, soil nails or the insertion of ties to stabilize the structure.¹³¹ Other options researched during this period that did not require loss of original fabric included grout injection and buttressing; though these methods retain fabric, they introduce

129 J. Delgado Rodrigues. "Dry-Stone Wall Monuments – Structural Behavior, Disturbing Mechanisms and Conservation Procedures." *In Engineering Geology of Ancient Works, Monuments and Historical Sites*. Marinos and Koukis, eds. Rotterdam: Balkema, 1988, 1001-1006.

130 G. Gudehus. "Geotechnical Protection of Historical Retaining Walls and Shallow Foundations." *The Engineering Geology of Ancient Works, Monuments and Historical Sites, Rotterdam, Balkema*. Marinos & Koukis Eds., 1990, 1957-1964.

131 *Ibid.*, 1958.

material to the original structure. Grout injections irreversibly alter the properties and form of the dry stone wall, while buttressing may aesthetically diminish the appearance. Alternatively, practices at certain Southern African sites included careful documentation and recordation of each stone to allow for reconstruction after collapse; the conservation program at these sites focuses on maintaining a high degree of integrity through minimal intervention, since current technologies for stabilization adversely impact the form and properties of the dry stone structures.¹³² The lack of knowledge of failure mechanisms and relatively low number of conservation publications has proven to be an area of weakness in the conservation field.

Current Literature (Since 2000)

In the past decade, engineering studies intending to reintroduce dry stone retaining walls in England and Continental Europe have been continuously published and enlarged in scope with the goal of reestablishing the traditional methods of dry stone construction and its aesthetic. These publications focus on establishing criteria to define safety factors and properties to predict failure. Engineering standards are necessary for current building practices in order for any structure—including retaining walls—to meet code specifications. Many studies quantify Coulomb's friction in an effort to establish the amount of overall cohesion and predict the amount of friction necessary to prevent shear failure.

By experimenting with full-scale test walls, several engineering studies identify wall stability by analyzing deflection caused by the incremental addition of backfill

132 P. J. Walker and J. G. Dickens. "Intervention Techniques in the Conservation of Dry-Stone Structures." *Conservation of Stone and Other Materials*. M. J. Thiel, ed. London: E&FN Spon, Vol. 2, 1993, 452-459.

applied to two types of dry stone walls.^{133, 134} These experiments serve as continuations of Burgoyne's original 1834 tests and employ walls of similar construction. Though Burgoyne's experiment advanced the understanding of failure mechanisms in the nineteenth century, technological advancements in computer modeling have enabled engineers to quantify friction and develop more reliable calculations to predict wall collapse. The attempt to calculate friction and, therefore, predict stability in historic sites, has limitations due to irregularities in the stone face. Harkness et al. and Powrie et al. simulated stone loss due to weathering by rounding the corners of each stone block, which reduces the cohesion. The original dimensions and design used by Burgoyne were maintained. The experiment—again applied to a 20' retaining wall—shows the direct relationship between amount of friction and deflection; in a battered wall with 19' of backfill, deflection increased from 6 cm to 10 cm when the corner radius increased from 1 cm to 2.5 cm.¹³⁵ The results indicate how detrimental stone weathering is in dry stone construction and emphasizes the importance of the stone interface in creating friction and preventing deflection. A second factor influencing stability is the backfill width. Reducing that width may increase stability by lessening pressure exerted by the backfill onto the wall.¹³⁶

Tests for dry stone wall stability include computing Coulomb's friction and using a limit equilibrium analysis to predict failure. Additionally, testing to determine stability under cyclic loading was conducted to increase knowledge of shear properties. Though loading can compress stones and create deformation, the results of the test found that shear strength increased during the first few loading cycles and then stabilized during

133 Powrie, Harkness, Zhang, and Bush. "Deformation and Failure Modes of Drystone Retaining Walls."

134 R. M. Harkness, W. Powrie, X. Zhang, K. C. Brady and M. P. O'Reilly. "Numerical Modelling of Full-Scale Tests on Drystone Masonry Retaining Walls." *Geotechnique*. 50:2. 165-179.

135 Powrie, Harkness, Zhang, and Bush. "Deformation and Failure Modes of Drystone Retaining Walls," 437.

136 *Ibid.*, 428.

successive cycles.¹³⁷ The test also determined that irregular surfaces ultimately contain the most friction between interfaces.¹³⁸ Even with the progress made through the engineering studies, failure under realistic conditions remains unquantifiable; however, establishing parameters for failure under ideal conditions does lend useful knowledge to the conservation field.

Conclusions

Computer-generated modeling has become popular in engineering publications to represent and predict failure modes in dry stone constructions. However, these models assume several factors when making these predictions: the wall reacts as one unit; the stones are homogenous (even if weathering has been accounted for by rounding corners); and the core is homogenous. When considering archaeological sites such as Gordion, many irregularities emerge in the structure and material. Conditions including missing chinking stones, lack of or failed connections and cracking affect structural movement and general performance; past seismic activity also influences stability and response to future movement. Though the models compute age and weathering by lowering the amount of friction (by decreasing the amount of stone interface), the wall is still represented in the calculations as a homogenous unit. The model simulations fail to consider the innate, heterogeneous quality of stone and any irregularities in the structure, which may result from original construction methods or uneven weathering patterns. These irregularities contribute to localized points of weakness and greatly alter structural performance.

The most recent publications mainly serve the engineering field and are directed

137 Paulo B. Lourenco, Luis F. Ramos, and Garca Vasconcelos. "On the Cyclic Behaviour of Stone Dry Masonry Joints." Proc. of Thirteenth International Brick and Block Masonry Conference, Amsterdam, 2004, 5.
138 Ibid.

at future construction of retaining walls. Though the application of these standards greatly contributes to knowledge in the conservation field, they are limited to a very specific type of dry stone wall, such as freestanding property dividers. The performance characteristics of retaining walls differ from those of freestanding structures. Soil backfill alters performance by applying pressure to the wall, which can cause deformation by sliding or bulging and can also reduce the stone interface and lower the amount of stabilizing friction.

Limitations on testing methodology arise through several factors. The tests conducted generally measure friction, compression, sliding and shearing on a limited scale. Most tests rely on a single interface between two stones to calculate cohesion and then apply that figure to the larger wall. Large-scale testing is relatively uncommon and does not utilize weathered stones. However, certain tests have accounted for weathering by reducing the contact area between stones. Still, these experiments relied on “ideal” dry stone walls (with unrealistic weathering patterns) and rigid foundations to ascertain moment of failure.

Another important limit in these experiments is time. Many studies note the period of settlement that occurs just after construction (or, in some cases, reconstruction) of the wall. Generally, observations show that after a year of settling, the masonry wall stabilizes, though it slowly and steadily compresses and moves in response to load patterns and the environment.

4.2 General Design and Properties of Freestanding and Retaining Walls

The complexity of dry stone wall construction and interaction of the components prevents the exact properties of each unique wall from being easily quantified. General characteristics emerge and are mainly attributed to construction technique and stone properties. Two basic wall constructions can be summarized by analyzing the typical dry

stone wall sections. Solid coursed ashlar stones generally comprise the core of the retaining walls examined in much of the literature. These walls can either contain a batter, are angled against the soil or are vertical (as in the models constructed by Burgoyne). Because of the relative homogeneity of this type of construction (compared to the extreme variations of the second type), these walls were used to calculate factors of safety and other data related to friction and stability.

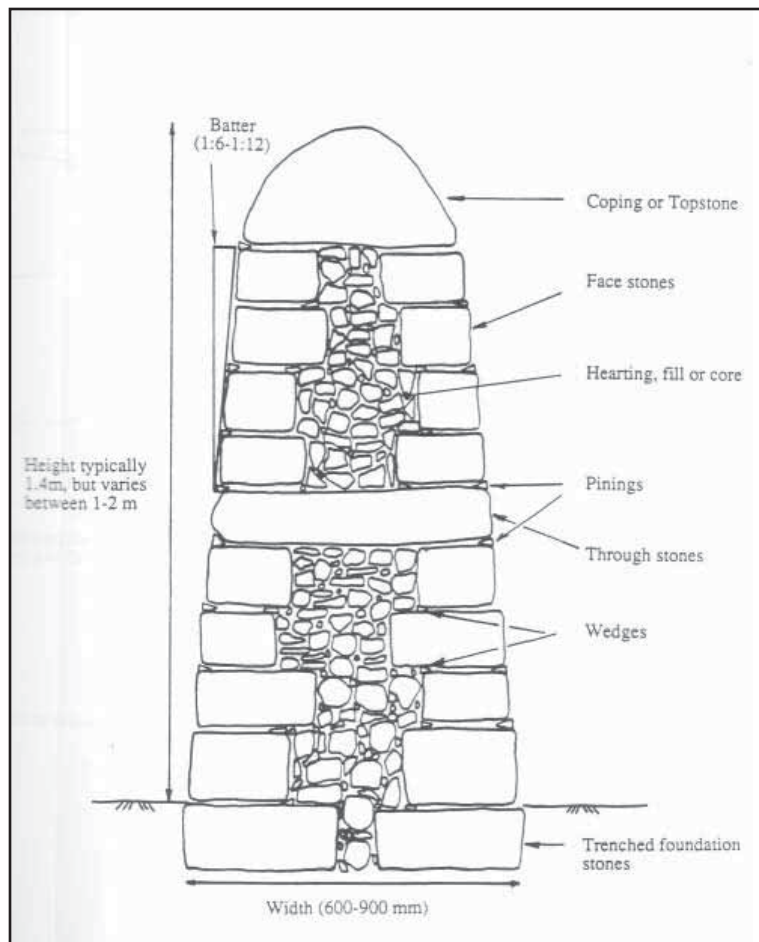

Illustration 6. Section of dry stone wall. *From Walker et al., Engineering Study, 1992.*

The second type of construction appears at many archaeological sites, such as Gordion and the southern African sites, and is much more difficult to quantify and use in predicting failure due to the degree of variation in construction technique. This type of dry stone structure is defined by the rubble masonry core and coursed ashlar veneer. A

tying mechanism—usually through stones or wooden beams—stabilizes the structure and fastens the veneers to the rubble core. Stones serving as pins and wedges (chinking stones) increase cohesion in the veneers and aid in distributing stress to reduce concentrations at specific points. Grading of the inner core allows compaction and better stability with more joint interface. This type of construction presents a unique conservation issue arising from potential instability of both the internal core and external face.

Each component in this second type of construction is important in contributing to structural stability and enabling the wall to move as a unit. Though dry stone walls are very resilient, flexible structures and can accept a significant degree of deformation without failing, they can develop points of weakness resulting from poor construction or flaws in a single component.¹³⁹ Because the greatest stability is achieved when the structure moves as a unit, serious design flaws can result from poor tying of the wall components. Additionally, chinking stones serve a similar function as traditional mortar (which redistributes stress and increases cohesion) and are integral in maintaining stability.¹⁴⁰ Loss of chinking stones can increase points of stress on localized areas and initiate movement.

The inherent weight of stone block structures and friction created between block interfaces generally prevent movement and lend stability to the structure. The individual properties of the stone control—to a certain degree—the amount of friction generated. As explicated in the literature review, rough stone faces (as those used in the archaeological sites) contain low initial contact but increase in cohesion as they wear. The texture, structure and strength of the stone type also influence the overall properties of dry stone walls.

139 J. Delgado Rodrigues. “Dry-Stone Wall Monuments – Structural Behavior, Disturbing Mechanisms and Conservation Procedures,” 1001.

140 Ibid.

Another aspect of design that determines properties of the overall construction includes the presence of a batter. The dry stone walls at Gordion generally contain a batter of approximately 5 cm for every 1 meter of height.¹⁴¹ Burgoyne's 1834 experiment confirmed the added stability produced by a batter, which increases resistance to overturning. However, the resistance to rotation does not eliminate the potential for bulging failures, which are common mechanisms affecting dry stone structures.

Though the complex dry stone construction generates a great deal of strength and stability, the walls are vulnerable to failure by the aging process, weathering, backfill settlement, environmental conditions (such as seismic activity) and increased loads.¹⁴² Both internal and external issues can affect the walls, and the degree of internal instability may not be known without investigation of the core material and tying mechanisms. Internal weathering and movement may not always translate to visible external conditions. However, advanced states of both internal and external deterioration are generally visible through pronounced bulging at the base (and sometimes middle) of dry stone structures.

4.3 Observations on Failure

4.3.1 Weathering and External Conditions

As evidenced in the recent engineering tests examined in the literature review, block interfaces generate the friction integral to wall stability. Because friction is produced through surface contact, the weathering of stone surfaces greatly impacts the overall cohesion and, ultimately, wall stability. Though drainage reduces the risk of bulging or

141 Kelly H. Wong. *Assessment of the Grout Used for the Structural Stabilization of the Early Phrygian Citadel Gate at Gordion, Turkey*. Philadelphia, PA: UPenn, 2006, 10.

142 Chris Mundell, John Harkness and Pete Walker. "Large Scale Testing of Drystone Retaining Walls." *Proc. of Structural Analysis of Historic Construction, England, Bath*. London: Taylor & Francis Group, 2008. 781.

toppling failure in retaining structures, environmental factors may still cause deterioration of individual stones.

Both internal and external components are susceptible to weathering from water ingress. Though the degree of tolerable deterioration cannot be quantified in rubble masonry constructions, the structure's flexibility allows a great deal of decay before failing. As dry stone structures weather, they may deflect several centimeters before regaining stability. This type of movement from water ingress can result in sliding/shear movement and bulging. Advanced weathering (which can also result from wind-driven deterioration) may disconnect or detach wall components.

Seismic activity also presents the potential for structural movement and can produce instability by weakening tie connections and reducing the amount of stone interface. Weakened connections decrease overall strength and create localized areas vulnerable to bulging or other failure. Vegetation growth—though a more gradual factor—can similarly impact stability by rooting in and cracking stones and accelerating weathering by holding moisture.

4.3.2 Toppling

Though a less common failure mode for walls constructed of a rubble core with an outer stone veneer, toppling occurs when the dry stone wall acts as a single unit and rotates at the base.¹⁴³ A wall topples when the pressure exerted by the soil backfill exceeds the pressure applied by the dry stone wall and results in overturning. Unlike bulging, which can be a very gradual displacement process, toppling occurs quickly and is less localized.

143 M. R. Cooper. "Deflections and Failure Modes in Dry-Stone Retaining Walls." *Ground Engineering*, 19:8, 1986, 29.

4.3.3 Bulging

Bulges form—generally at the base of dry stone walls—from small, incremental forward movements of the stone blocks. Two forces can cause bulging in retaining walls: if the upper part of the wall tilts back due to pressure, or if the stone components lose strength/mass and rotate forward at the base from compressive forces.¹⁴⁴ The latter bulging mechanism is more common and creates the typical convex profile.

Bulging generally appears in aging dry stone walls as a consequence of weathering. As decay to stone surfaces increases due to weathering, the structure loses friction between interfaces from decreased contact, which causes slight displacements until the structure stabilizes. Due to the flexible nature of the wall unit, these slight periodic movements may create deformations, but do not necessarily denote the structure's impending failure. Powrie et al. note that because "walls can stand for long periods before collapsing, [it appears] that collapse might be triggered by a time-related deterioration in the block interface properties."¹⁴⁵ The complexity of materials and construction prevent correlations between amount of deflection and time of failure from being established.

Also important for understanding failure modes related to joint interface and bulging is the friction angle. The friction angle helps to predict possible failure modes. Movement in a wall with a low friction angle would result in sliding of the blocks, which is more commonly encountered at the wall base due to the concentration of lateral force.¹⁴⁶ Wall constructions with a friction angle less than 20° generally fail more often by toppling—a result caused by destabilization from sliding—than those with a higher joint

¹⁴⁴ Ibid., 29.

¹⁴⁵ Powrie, Harkness, Zhang, and Bush. "Deformation and Failure Modes of Drystone Retaining Walls," 441.

¹⁴⁶ Ibid., 439.

inclination.¹⁴⁷ Understanding the mechanics of a wall based on its friction angle offers information regarding the type and possible location of movement.

Inherent flaws can surface from design and construction techniques. Coursed ashlar construction produces regular, horizontal planes with lower internal stability. These even courses with horizontal joints leave the wall susceptible to shear displacement. Conversely, dry stone walls with a well-graded, rubble core exhibit increased stability, since the varying stone shapes and sizes compact or interlock and increase the level of friction without creating horizontal or vertical planes of weakness.¹⁴⁸

Though the failure modes are generally understood, the amount of deflection tolerated and time until failure is not. Failures can occur suddenly, or dry stone walls can survive with bulges for decades without collapsing.¹⁴⁹ Though dry stone testing can compute the total friction necessary to maintain stability, the amount of true joint interface friction in these walls is not quantifiable—especially in complexly constructed walls such as Gordion’s Early Phrygian Gate where a limestone veneer encases the rubble core, and the core components, extent of internal stone decay and resultant deformation remains generally unknown.

4.4 Conservation Methods for Dry Stone Structures

Several techniques have been developed to stabilize dry stone walls, including soil nailing, pinning and injection grouting. Used only on retaining walls, soil nailing increases structural stability by tying the wall to the soil backfill. The other interventions can be applied to either freestanding or retaining structures. Each system affects the appearance

147 Ibid., 441.

148 Delgado Rodrigues. “Dry-Stone Wall Monuments – Structural Behavior, Disturbing Mechanisms and Conservation Procedures,” 1003.

149 Mundell, Harkness and Walker. “Large Scale Testing of Drystone Retaining Walls,” 781.

and performance of the wall to varying degrees. While injection grouting introduces additional material into the wall system, pinning and soil nailing result in localized losses of fabric. Though other interventions exist—such as reconstruction and geotextiles—soil nailing, pinning and grouting are common interventions at historic sites.

Soil nailing provides resistance to overturning and bulging by anchoring the wall to the backfill and redistributing the load to the added concrete element, which is installed between the wall and abutting soil.¹⁵⁰ Soil nailing requires boring into the wall for the insertion of a steel rod and adding gravel to increase contact between the structure and rod. Concrete blocks bedded in the soil behind the wall act as anchors (in addition to their load-bearing function). The method results in a loss of fabric and can create material compatibility issues between the rod/concrete and stone. Though the nails are angled 30° to increase the efficacy of anchoring, they prove detrimental to walls with large bulges or instabilities due to the installation procedure and required drilling. The drilling process and temporary reduction of fabric may further destabilize the structure prior to installation of the soil nails.

As a similar method, pinning also increases stability through the insertion of a stainless steel or fiberglass rod. Because the tying mechanism enables more deflection to occur before failure, the rods supplement any existing tie beams or through stones to increase the amount of tolerable deflection. Particularly effective in multiple leaf structures, this method binds the outer veneers with the core material and also acts to prevent core settlement and deflection of the veneer.

Though already considered as an intervention to stabilize structures in seismic regions, injection grouting is also used as a general measure to prevent incremental

150 W. Wehr. "Stabilisation of Retaining Walls with Non-Grouted Soil Nails." *Ground Improvement* 7:4 (2003): 174.

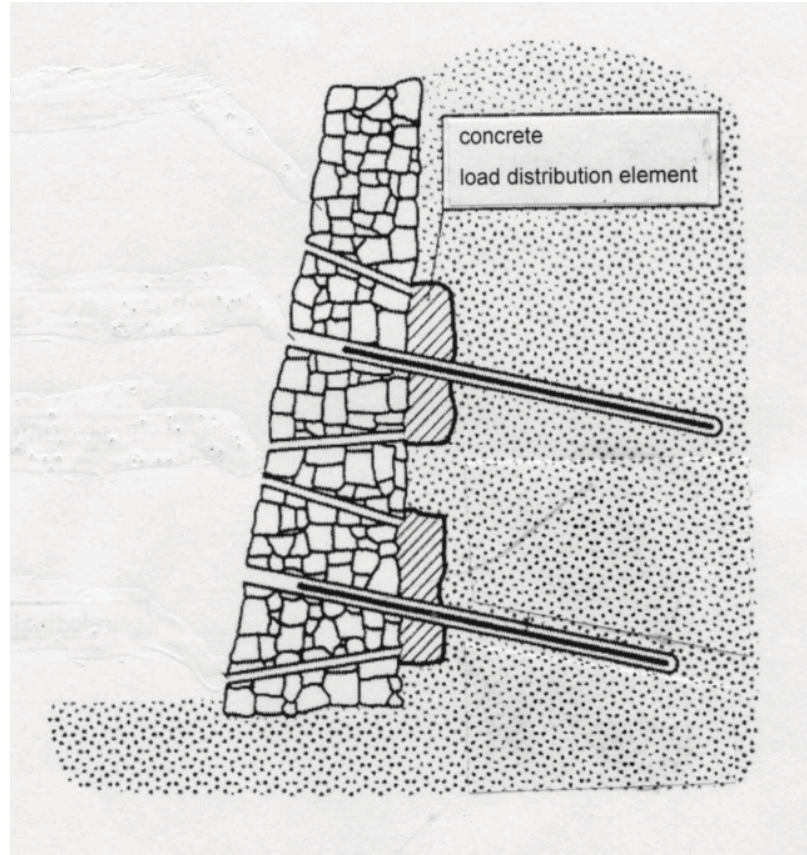

Illustration 7. Intervention technique which uses soil nails to secure wall to backfill. *From Wehr, 2003.*

displacements produced by all dry stone structures. Developed for the purpose of increasing bond strength and redistributing loads, grouts injected into the dry stone wall fill voids and increase continuity.¹⁵¹ The injected material varies and can include resins and polymeric and cementitious grouts. Efficacy depends on material compatibility, penetration within the wall to fill voids, and durability in a particular environment.¹⁵² Though injection grouting has been found to improve strength, the process remains invasive—as are the other interventions—by changing the wall properties and aesthetic.

151 Miha Tomazevic. “Laboratory and In Situ Tests of the Efficacy of Grouting and Tying of Stone Masonry Walls.” *International Workshop CNR-GNDT. Proc. of Effectiveness of Injection Techniques for Retrofitting of Stone and Brick Masonry Walls in Seismic Areas, Italy, Milan*. Ed. L. Binda, 96.

152 Luigia Binda, Mario Berra, Giulia Baronio and Alberto Fontana. “Repair of Masonries by Injection Technique: Effectiveness, Bond and Durability Problems.” In *Structural Conservation of Stone Masonry. International Technical Conference, Athens, 1989*. Rome: ICCROM (1990), 432.

4.5 Case Study: The Great Zimbabwe National Monument

The Great Zimbabwe National Monument serves as a comparable site and the preservation efforts should be analyzed. The monument—a site which predates the construction of the Gordion complex—includes both freestanding and dry laid granite retaining walls. The Great Zimbabwe walls contain similar characteristics to those of Gordion: two outer veneers encase an inner rubble core; chinking stones distribute stress and increase friction; a tying mechanism—through stones—binds the components; a coping stone (which serves a function similar to the gate’s concrete cap) also lends stability and reduces weathering from water ingress.¹⁵³



Figure 29. Great Zimbabwe National Monument, Africa. *From www.content.lib.washington.edu*

Parameters of conservation study required new methods for preservation. Methods to stabilize retaining walls in the United Kingdom by grouting and the restacking of walls generally implemented in southern Africa were deemed inappropriate for the archaeological

153 P. J. Walker and J. G. Dickens. “Intervention Techniques in the Conservation of Dry-Stone Structures.” *Conservation of Stone and Other Materials*. M. J. Thiel, ed. London: E&FN Spon, Vol. 2, 1993, 453.

site. The conservation team determined that a certain level of authenticity would need to be maintained at the Great Zimbabwe National Monument, so any alteration of appearance (such as the introduction of any new material—grout or replacement stones) was not acceptable.¹⁵⁴

Though both bulging and toppling failures have occurred, bulging presents the most problematic failure mode at the site. The sloped granite foundation, lack of through stones and general construction has also produced shear and sliding failure.¹⁵⁵ Conservators at the Great Zimbabwe National Monument implemented a monitoring program using glass wires to determine in-plane movements. This technique only indicated if the structure moved but could not quantify the movement.¹⁵⁶ A more advanced system using demec strain gauges and survey triangulation was also created to measure movement of the bulges.¹⁵⁷ “Stick-slip” displacements were found to correspond with climatic conditions; movement generally occurred during the rainy season.¹⁵⁸ Movements related to significant water ingress occur due to increased soil pressure, reduction of friction from soil entering the joints and the lubrication of joints from water, in addition to the incremental weathering of stone caused by the moisture permeation.¹⁵⁹

Conservation techniques involved increasing long-term stability through several factors, which included improved construction, drainage, lateral support and foundations.¹⁶⁰

154 Ibid., 452.

155 Ibid., 454.

156 Webber Ndoro. “Restoration of Dry-Stone Walls at the Great Zimbabwe.” *Archaeological Site. Conservation and Management of Archaeological Sites* 1.2 (1995): 89.

157 Walker and Dickens. “Intervention Techniques in the Conservation of Dry-Stone Structures,” 455.

158 Ibid., 455.

159 J. G. Dickens and P. J. Walker. “Correlation of Structural Movements with Joint Characteristics on Dry-Stone Walls.” In *Structural Repair and Maintenance of Historical Buildings IV*, Vol. 1: Architectural Studies, Materials and Analysis. Proceedings of the 4th International Conference, Chania, Crete, 22 - 24 May 1995, Brebbia & Leftheris (Ed.). Southampton: Computational Mechanics, 1995, 364.

160 Walker and Dickens. “Intervention Techniques in the Conservation of Dry-Stone Structures,” 457-8.

The addition of horizontal connections supplemented existing, weak connections.

Remediation options presented to improve the foundational stability, as well as the proposed reconstruction of certain walls, challenged the site's preservation program of maintaining authenticity of the dry stone construction.

The discussion on authenticity poses an interesting and inherent contradiction at this site. The solution developed to address foundational and structural instability involved dismantling and rebuilding the wall to improve original construction techniques (mainly by upgrading through connections to increase lateral support and cutting into the bedrock to level the foundation).^{161,162} Though not as invasive as other interventions, such as pinning and grouting, the rebuilding process improved historic construction methods, which permanently altered the original technique. Though no one conservation intervention applies universally, solutions to structural instability of dry laid masonry systems must consider the unique construction techniques employed in addition to alterations in aesthetic and fabric.

161 Ibid., 458.

162 P.J. Walker and J.G. Dickens. *An Engineering Study of Dry-Stone Monuments in Zimbabwe*. Vol. 1. Loughborough: Loughborough University of Technology, 1992, 425.

5.0 DIAGNOSIS OF CONDITIONS

5.1 Conditions Survey

The gate, including the North and South Court walls, was surveyed during the summer 2006 season as a preliminary measure for documenting overall conditions and planning future monitoring.¹⁶³ Photomontages of each elevation and plan drawings of the court roofs served as the base maps for hand recording.¹⁶⁴ The survey indicated the type and location of conditions and also recorded past interventions, such as injection grouting, capping and partial reconstructions. The annotated montages were then digitized in AutoCAD to create a visual map of each elevation as a tool for constructing relationships between conditions and identifying patterns to develop preliminary causes for the different types of displacement found at the site (*refer to Appendix A for condition drawings*). The conditions recorded during the survey process included:

- **Cracking:** both large-scale cracking through multiple stones and small-scale cracking through individual units
- **Split Face:** a rough, uneven surface on the veneer face
- **Open Joints:** areas which show a separation between adjacent stones
- **Missing:** broad classification for both missing veneer stones or small chinking stones
- **Spall:** a condition resulting in the detachment of a partial or entire stone face

¹⁶³The condition survey was designed and completed by Kelly H. Wong, Post-Graduate, University of Pennsylvania and Gülsün Özkan, Intern (METU).

¹⁶⁴The photomontages were printed and used in the field to manually notate observed conditions of each elevation.

In addition to the 2006 survey, historic images taken of the walls during excavations in 1955 were used as a comparison. These historic photographs offer some level of correlation between cracking, bulging or shearing and the load patterns from the later Middle Phrygian gate. The comparison also delineates conditions existing in 1955 and those that developed in the decades following excavation. Though the survey only records observed conditions and does not establish whether or not the conditions were the result of active or inactive mechanisms, it does provide a map of crack patterns and displacements and identifies high-risk areas of instability.

The goal of the present diagnosis is to identify patterns and trends of material deterioration and structural damage, to determine whether those patterns result from past conditions or developed recently, and to attempt to posit cause/effect relationships. The results of this assessment will inform the future monitoring program required to confirm active conditions. This assessment must answer several questions before implementing a successful monitoring program: what needs to be measured, what resolution is required to detect displacement, is more than one type of displacement possible, what devices are required, where should the devices be located?

5.2 Limitations of Survey Methodology

Some limitations involving site access, construction of the gate, and assumptions of soil-structure interaction should be noted. Access to all walls of the North and South Courts was not possible due to the state of excavation. Elevations surveyed include the south exterior and all interior elevations of the North Court, and partial elevations of the east and north exterior walls. The South Court elevations surveyed include the north elevations, the adjacent west elevation and part of the east wall. Because the South Court

remains partially excavated, the interior elevations are not visible.

The scaffolding in the gateway also reduces accessibility and visibility while surveying. Areas of the northeast elevation of the South Court and the southeast elevation of the North Court were surveyed from a distance. The soil abutting the east and north exterior elevations of the North Court limited access to these walls. As a result, the montaged images contain some distortion due to the angle required to photograph the elevations.

Some assumptions regarding the effects of the soil-structure interaction were drawn, though further testing is necessary to confirm the properties of the soil. However, the remaining clay construction fill—present on the north and east exterior walls of the North Court and interior of the South Court—has great ramifications for the current conditions and must not be excluded as a factor contributing to displacement. It has been assumed that lateral forces are being exerted on the unexcavated portion of the elevations and displacements below the fill level are likely occurring; the extent to which the soil-structure interaction has led to out-of-plane movement is not quantifiable. Laboratory testing of soil properties (such as soil volume expansion and Atterberg limits) and monitoring of the soil can indicate the amount of volumetric expansion of the clay backfill and any resulting wall displacement.

In areas with an exposed outer face, ascertaining the overall pattern of displacement is difficult, since the wall consists of multiple leafs. Displacement of the outer veneer does not provide evidence of interior movement. Without the ability to observe the entire wall system, it cannot be determined whether out-of-plane displacement (i.e. bulging) results from lateral pressure exerted by the clay backfill or settlement within the rubble core. Each mechanism may produce similar conditions; however, they occur differently and require

separate methods of intervention. Bulges occurring from lateral loads affect the entire three-leaf system. The displacement occurs on the inner veneer and thrusts the rubble core and outer veneer out-of-plane. Settlement of the rubble core results from ground movement and water ingress, which deteriorates stones and reduces stability. As the core slips past the angle of repose, it applies pressure to the outer veneer in localized areas—producing either a separation of the veneer face or bulging.

Unknown factors also limit the ability to correlate conditions and mechanisms of deterioration. Those factors include the extent of deterioration behind the outer veneer and the amount of stone contact within the core and between the core and veneer. Though evidence of wooden tie beams was found, the number and current efficacy of those beams is unknown. Other unknown details include the settlement of the rubble core within the structure and differential settlement of the entire wall system due to the uneven loads exerted by the Middle Phrygian walls. Also, the exact historic load patterns remain unknown. Because the walls were partially dismantled during the Middle Phrygian reconstruction, the presence of a coping stone or crenellated top is assumed but not known. The current unfinished state results from the removal of the top courses to provide a flat foundation for the later gate structure.

Other general assumptions relate to properties of the limestone and rhyolite. Due to the age of the structure, the stone has naturally weathered and increased in surface porosity. Consequently, water ingress can be particularly damaging to the structure and, given the extreme cold and precipitation occurring in the winter months, can lead to freeze/thaw action. Freeze/thaw heave of the clay backfill can cause additional pressure to be applied to the retaining walls of the South Court. Water also presents a more serious condition when penetrating the core material. If weathered, the core material loses mass

and its frictional stability, which leaves stones susceptible to settlement and increased lateral pressure on the veneer stones.

5.3 General Conditions Affecting the Citadel Gate

Several types of displacement have been identified within the gate complex: out-of-plane movements, which include sliding, bulging and rotation; and in-plane movement, such as shearing. Both the North and South Courts show signs of bulging. The out-of-plane movement appears to have occurred mainly below areas where sections of Middle Phrygian wall remain, though these bulges developed in different patterns below the later structure. The areas also exhibit extensive compression cracks, split faces and spalls. The patterns indicate the compressive force exerted by the Middle Phrygian walls has contributed greatly to the current conditions of the Early Phrygian Gate. Because excavations decreased the load bearing on the underlying gate with the removal of the Middle Phrygian construction, many of the split faces may be past conditions caused by the excessive load of the later walls. However, even past conditions contribute to present deterioration by increasing surface area of individual stone units and allowing moisture to penetrate the veneer. Cracks and open joints especially leave the masonry structure susceptible to weathering due to water ingress. The moisture penetrating the core can cause settlement by eroding the stone and causing voids by transporting fines out of the wall.

Past interventions similarly heighten the risk of deterioration when not properly maintained. Sections of both courts received concrete caps intended to eliminate water penetration into the rubble core. Localized spalls, large-scale cracking and detachment of the cap from the masonry below were identified in the condition survey. These weaknesses in the cap show some correlation to conditions occurring within those areas of the gate

walls. Conditions relating to cap deterioration generally appear as open joints, erosion or biogrowth.

The other major intervention affecting site conditions is injection grouting, which was used recently to stabilize high risk areas susceptible to out of plane displacement.¹⁶⁵ Because the grout injections were started during the 2002 season, no visible response of the structure to this form of intervention has emerged. Movement following injection grouting will require several monitoring systems in order to identify current displacements and, if found, type of displacement. Prior to grouting, the bulging occurred as out-of-plane movement in central areas of the elevations; following the grouting process, the type of movement may change. The increased bond of the lower courses leave the upper courses susceptible to movement. Rather than out-of-plane movement, the wall may also rotate as a single unit (possibly leading to toppling from the stiffened base). Additionally, weep holes were not found in the north elevation of the South Court when grouted. The closure of formerly open joints from grout and the lack of weep holes could increase hydrostatic pressure within the system (particularly concentrated at the base) and contribute to the deterioration mechanisms in the courses above the grouted area.

General instabilities were recorded in areas adjacent to or containing clay backfill in both North and South Court walls. The unexcavated construction fill used by the Middle Phrygians to level the earlier city consisted of highly expansive red fan clay. This clay mobilizes in water and, when confined within the interior courts, will exert pressure on the walls during periods of precipitation. Because much of the North Court has been cleared, most instability resulting from Middle Phrygian construction fill appears in the unexcavated northeastern corner, though the soil backfill likely affects adjoining walls. The

165 Kelly Wong. Field Notebook: Gordion Architectural Conservation Citadel Gate 2006 Season. Philadelphia: University of Pennsylvania, School of Design, Architectural Conservation Laboratory. 2006, 16.

unexcavated interior of the South Court is even more vulnerable to displacement from the expansive clays and evidence of conditions resulting from lateral force emerge in all exterior elevations.

5.3.1 Assessment of North Court Conditions

The southeast corner presents a major area of concern in the North Court. Examination of the plan shows the east wall narrows in width as it intersects with the southern wall. Though the southeast elevation was completely excavated, the east wall remains partially buried below the Middle Phrygian construction fill; only the southeastern corner is exposed to the original grade of the gateway. During the excavation period, Young's team uncovered the entryway initially to establish the distance between the courts.



Figure 30. Excavation of the gate entryway. *From the Gordion Archives, ca. 1955.*

Because several courses of the Middle Phrygian gate rest on top of the southeast portion of the wall, a correlation between load and conditions can be established. Multiple visible conditions indicate movement in this location and include: an area of major loss in both the southeast corner of the east elevation and the northeast corner of the adjacent south elevation, significant spalling, vertical and horizontal stepped cracks and a series of open joints. Young noted in his 1955 excavation report that the wooden foundation beams once supporting the structure had disintegrated below the southeast elevation and caused the weight to shift forward; Young believed the load was redistributed after the decay and applied to the ledge, which acted as a counterbalance to prevent toppling.¹⁶⁶ Evidence of cracking around the ledge due to excessive pressure along the wall base existed at the time of the 1955 excavation.



Figure 31. Depiction of molded clay which formerly surrounded structural timbers.
From the Gordion Arhives, ca. 1955.

166 Rodney SYoung. "The Campaign of 1955 at Gordion." *American Journal of Archaeology* (1956) 60: 259.



Figure 32. Southeast elevation of the North Court showing vertical cracks. *From the Gordion Archives, ca. 1955.*

The vertical cracking visible directly below the remaining Middle Phrygian wall indicates a large compressive force is being applied from the uneven load. Images from the 1955 excavation season indicate that displacement had already occurred in this localized area. The image shows the emergence of the vertical crack around the ledge, though this condition has worsened since excavation. The earthen finish still extant on the wall following excavation disguises any historic shearing directly below the Middle Phrygian stones. Currently, several shear cracks and a slight depression have formed in the top eight courses. Both conditions appear to relate to the later wall above, however, poor quality masonry may also have contributed to the emergence of the depression. The stone units in this section exhibit a high amount of split faces, and the loss of material within the veneer stones likely caused the depression to form.

Both the deteriorated wooden foundation and the weight of the Middle Phrygian blocks have produced the slight incline toward the gate's entryway, which has applied excessive pressure on the ledge. The combination of these forces also resulted in shearing at the corner and significant cracking. Because of this forward movement, a vertical stepped crack has developed in the interior south elevation. The crack also exists in historic photographs taken just after excavation, which also supports the correlation between historic load and displacement. The pattern of the crack indicates the wall had moved as a single unit—rather than a separation of veneer from the rubble core. Given the weight of the southern elevation and the narrowed section of wall on the east, the strength of the corner would be slightly diminished from the lack of mass/bonded masonry.

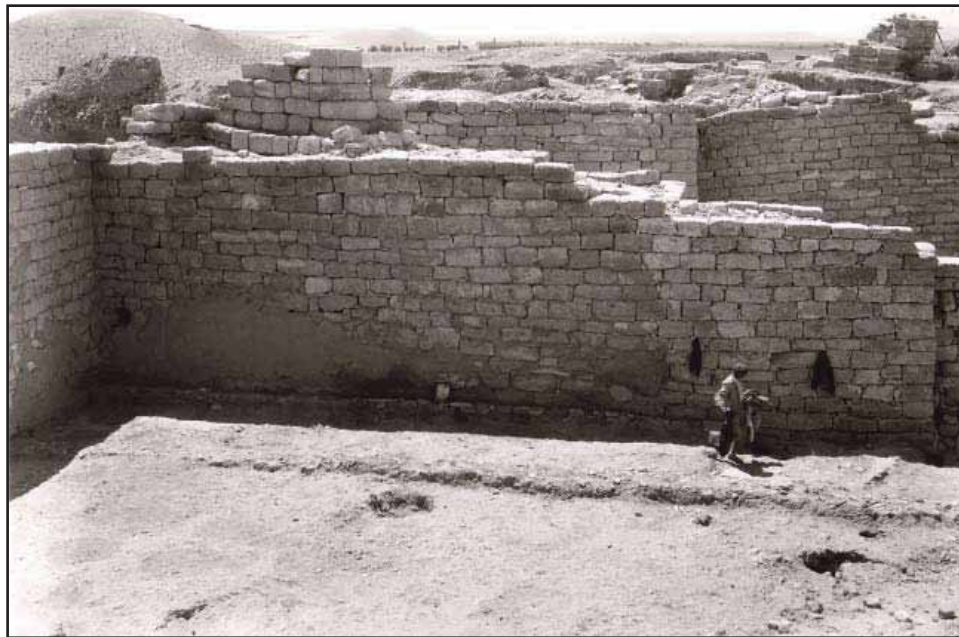

Figure 33. Southern wall of the North Court interior illustrating sheared open joints, vertical stepped cracks and compression cracks. *From the Gordion Archives, ca. 1955.*

Other conditions affecting the stability of individual walls emerge in the northeastern portion of the North Court. Small bulges have developed in both interior walls at the northeast corner and likely result from both compressive forces of the later

Middle Phrygian structure and lateral pressure from soil backfill, since the exterior fill abutting the northeastern walls was not cleared during excavations. A significant length of the Middle Phrygian structure spans both walls and has resulted in compression cracking—particularly evident in the east interior elevation. Joints in this location have also sheared and likely exerted some force toward the inner corner. Though bulging generally occurs at the base of a wall, the bulge in the east elevation is visible at the top, directly below the remaining Middle Phrygian courses. These types of bulges result from compressive forces and appear as a backward tilting action.



Figure 34. East interior wall of the North Court with shear cracks from the remaining Middle Phrygian wall. *From the Gordion Archives, ca. 1955.*

The backward rotation may provide evidence of core settlement and, though images from 1955 prove the condition is historic, it may be exacerbated by several current enabling factors. A concrete cap spans the entire length of the interior east elevation, however, the Middle Phrygian courses create an intersection between the later structure and protective

cap. Several points along this juncture have detached and allowed water to permeate the core in the area above the bulge. The water penetration will continually weather the core material and reduce its stability. Also, the load distribution in this northeastern corner is not known, since conditions of the opposite exterior face are not visible due to unexcavated fill. As the thickest section of all North Court walls, it is less likely that the soil fill is exerting excessive force on the inner portion of the wall. However, if core settlement continues due to weathering, the Middle Phrygian load may shift and begin to exert pressure on the interior veneer as a result of the increasing instability of its foundation material.

The adjacent interior wall within the North Court exhibits a more common type of bulging at the base. Because the north interior elevation is not situated directly below the Middle Phrygian wall, causes of bulging at this location differ from those of the east interior elevation. The slightly convex appearance of the wall seems to have existed historically and may be the effect of several factors. The extensive shearing of the east interior elevation is evident in Figure 34; this shearing action may be generating force in the northern direction and causing a backward rotation of the north wall. A second possibility includes the lateral load exerted from the north exterior fill. The wall section at this elevation narrows to a normal thickness of three meters, which resists less lateral force than the uncharacteristically thick northeastern corner. As a result, the soil backfill may be exerting pressure on the wall and instigating the displacement.

Though monitoring of this area is necessary to confirm the cause of displacement, a tap test of the concrete cap conducted during the condition survey indicates some movement or change within the core.¹⁶⁷ Several hollow areas were recorded, which

¹⁶⁷Wong, *Field Notebook: Gordion Architectural Conservation Citadel Gate 2006 Season*, 37.

included the area directly above the bulge. The hollow sound produced by the tap test denotes localized settlement or a reduction of interior material. Settlement of the rubble core also increases the lateral force exerted on the outer wythes and produces a bulging effect. However, the tap test cannot determine the cause of settlement within the core.

Most conditions affecting the North Court likely occurred while the structure supported the later Middle Phrygian gate. Material losses in the form of split faces and spalls correspond to areas of higher compressive loads. The forward rotation of the southeast corner appears to have temporarily stabilized; however, monitoring of this critical intersection is necessary, since it presents the greatest risk to the North Court's stability.

5.3.2 Assessment of South Court Conditions

Similar conditions affect the South Court— though to a greater degree and resulting in a higher level of instability than the North Court conditions. Shear movement, rotation and bulging appear throughout the exterior elevations, and the partial excavation of the court has left the clay construction fill confined within the interior walls. Because the red fan clay is highly expansive, it will exert lateral pressure on the court walls. Other factors affecting the South Court includes poor drainage, failures in the concrete cap and differential loads from the previous Middle Phrygian walls. The injection grouting completed at the site during the past decade has altered the wall properties by filling some voids within the rubble core and closing open joints in the outer veneer. The grout theoretically increases the bond strength of the core and veneer, however, the internal bonded area and efficacy of the process remain unknown, as do the changes in response to ground movement and lateral forces.

The greatest threat to the South Court's stability developed during the decades

following excavation. Historic photographs taken during the 1955 excavation season reveal some degree of instability; however, only an indication of the emerging bulge existed in the northeast elevation at the time. An analysis of historic images depicting the northeast elevation shows a central depression in the upper six courses of the veneer, which likely result from settlement in the rubble core. With the exception of this convex area, the battered wall maintains a relatively straight incline (i.e. the bottom does not exhibit a bulge).

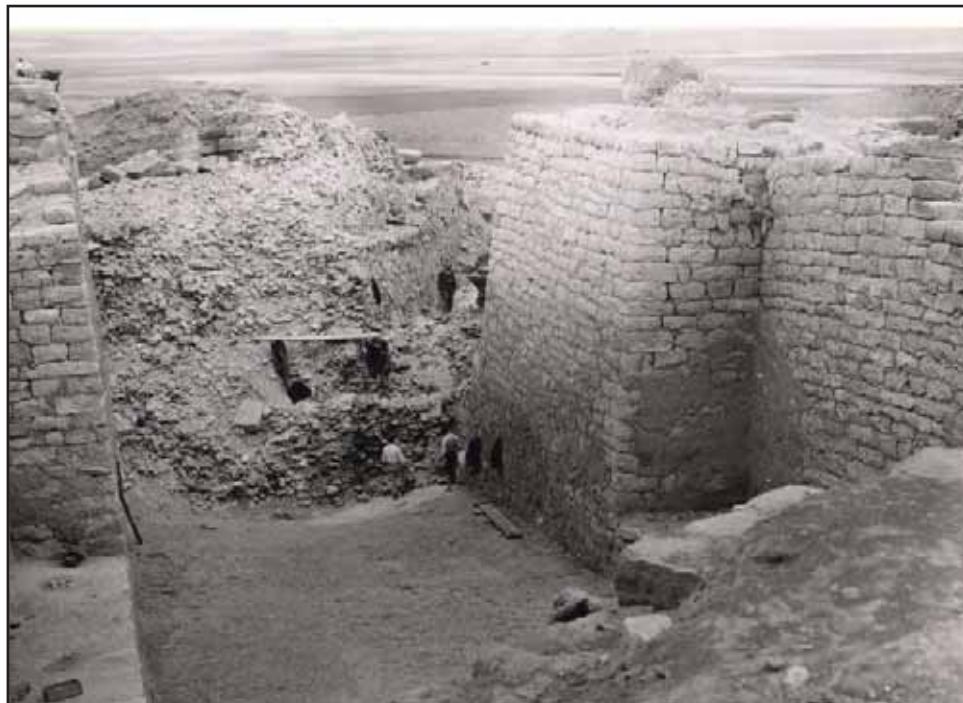

Figure 35. The convex area is evident in the upper courses of the northeast elevation of the South Court. *From the Gordion Archives, ca. 1955.*

When examining the wall from the west, more displacement is visible in the return. The vertical stepped cracks provide some indication of the severity of displacement. The veneer stones of the northeastern elevation appear to be separating from the core—particularly in the central region of the wall where the cracks are largest. Other evidence

of movement found in the west return includes the missing area where the wall abuts the northwest elevation and the extensive cracking and slight bulge in the veneer stones at the upper portion of the wall.

The large bulge in the northeastern elevation was first identified in the 1970s and has incrementally enlarged in recent decades.¹⁶⁸ Following the 1999 Izmit earthquake, measurements taken using plumb lines indicated 3-4 centimeters of movement in the central portion of the bulge.¹⁶⁹ The ground motion during the seismic event likely mobilized the core material and caused further settlement. Prior to the event, incremental movements were recorded but considered nonthreatening.¹⁷⁰



Figure 36. Displacements of the rubble core have increased the size of the bulge in the South Court wall. *By Goodman, 2000.*

The incremental movements may not only result from core settlement. Shear movement produced by either the expansive clay backfill or prior Middle Phrygian load

168 Wong, *Field Notebook: Gordion Architectural Conservation Citadel Gate 2006 Season*, 23.

169 Mark Goodman, *Architectural Conservation at Gordion: Summer 1999*. Gordion Excavation Project 1999, 5-6.

170 *Ibid.*, 5.

is evident in the east elevation. Historic images illustrate that much of the displacement on the southern portion of the wall existed in 1955. These images also supply evidence of missing stones in several sloped areas; current images show that missing veneer stones have been replaced, though these areas remain sloped and channel water runoff.



Figure 37. The east elevation of the South Court shows missing stones and depressions in several areas. *From the Gordion Archives, ca. 1955.*

Other evidence of displacement provided by historic images of the east elevation includes cracking in the bottom northeastern corner. The condition mirrors the cracked ledge on the opposite North Court wall, which suggests a similar type of movement has occurred in the South Court. The crack in the North Court ledge formed from a rotation about the base caused by disintegrated foundation timbers. Likely bedded on similar material, the South Court exhibits signs of sliding rather than rotation due to the deteriorated foundation. Pronounced shear cracks developed in the east elevation and provide signs of a northward movement. This displacement accounts for the apparent

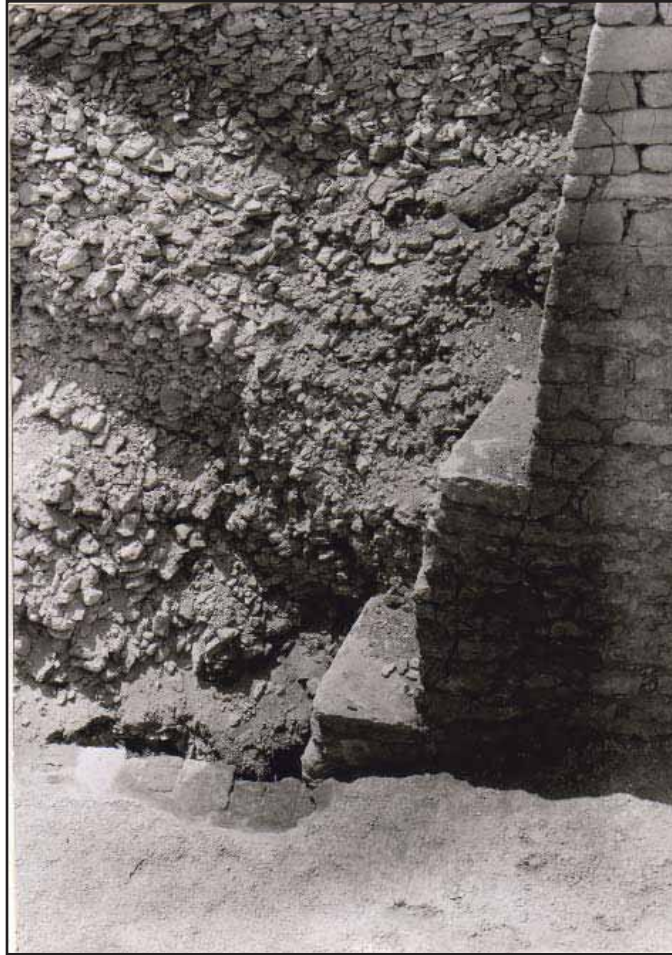

Figure 38. Cracks are visible in the South Court's northeast elevation during excavations. *From the Gordion Archives, ca. 1955.*

separation of veneer stones visible on the west return (as well as the vertical open joint pattern).

As mentioned previously, the confined backfill becomes highly mobilized when wet and exerts lateral pressure on the enclosing walls. The force generated from soil expansion may produce sliding at the northern end, since no opposing force exists. Additionally, archaeologists excavated the northeastern corner of the South Court during their initial investigation of the gate complex. After establishing the location of the South Court, the team excavated the central gateway, which left only the northern elevation exposed. All other elevations—including the east elevation, which is currently partially excavated—

remained buried under the clay construction fill. During this state of excavation, the soil could have exerted significant force against the back of the exposed wall. Several shear cracks appear at the base and indicate that the force was concentrated in this region. A vertical stepped crack in the east elevation shows the point of detachment where the northern portion of the wall slides into the gateway. The sliding at the base could have affected the upper courses of the northeast elevation by leaving them susceptible to backward sliding—a very strong possibility when considering the concave appearance of the elevation.

To provide additional cohesion to the bulging area, a program involving gravity injection grouting was implemented in the northeast and adjacent northwest elevations. The grouting process left the bottom half each elevation grouted and bonded many of the bulging veneer blocks in the northeast elevation. Because gravity grouting increases the bond strength within the wall, injected areas react to loads differently than dry laid stones, tending to move as a single unit. The complexity of the multiple leaf wall prevents future behavior from being accurately predicted, especially given the difference in grouted and ungrouted areas within a single elevation.

The upper portion of the grouted north elevations still exhibit extensive open joints, vertical and shear cracks and split faces. Though many conditions occurred prior to excavation (particularly split faces), the wall remains vulnerable to displacement from lateral thrust. Grouting was used as a preventive measure to diminish shear or out-of-plane movement. The base grouting may inhibit the shearing action prevalent in the northwest elevation, however, new mechanisms of displacement may emerge. As a bonded unit, lateral thrust could cause a forward rotation about the base and eventually cause toppling. The probability of this mechanism occurring is heightened by the lack of weep holes in the grouted

system to allow for drainage. Without a drainage source, water entering the wall can produce hydrostatic pressure within the ungrouted voids and increase the lateral force.

An additional grouting effort was completed on the east elevation, which exhibits further structural conditions south of the area of detachment. The grouting targeted the bottom 3-4 courses above current ground level where multiple areas of instability have been identified. This area also includes a small bulge in the center of the excavated portion of the wall. The general mechanisms affecting the east elevation consist of differential load patterns, poor drainage due to a sloping elevation of the interior court and lateral pressure from the clay backfill.

The unexcavated backfill largely drains to the west; however, a slope toward the east directly above the elevation enables water to flow toward the east face of the wall. Water may have weakened the masonry units where visible depressions underlie Middle Phrygian remains. These concentrated areas of loss occur in two locations at the top of the wall and contain an unusually high number of split faces. Displacement is evident as multiple stepped cracks in the center and southern end of the elevation. Displacement could result from sliding of wall sections due to the placement of the Middle Phrygian wall, the lateral force exerted by the clay backfill, or from the shear movement at the northern section.

A bulge may be forming in the southern end of the wall. This area remains confined by unexcavated fill and displays a large amount of open joints below several Middle Phrygian blocks. With no evidence of in-plane shearing, the network of open joints may demonstrate out-of-plane shearing—or bulging—from the combination of lateral pressure and compressive force. The area south of the sheared end remains uncapped and is more vulnerable to water ingress. Without excavation images, historic damage cannot be differentiated from active deterioration.



Figure 39. The general instability is evident in the South Court, which is only partially excavated. *By Wong, 2006.*

The east elevation generally shows greater signs of instability from residual Middle Phrygian construction and lateral soil pressure. The extent of damage from seismic activity has been recorded in the northeast elevation; however, damage within the core cannot be quantified but is assumed to have occurred. The scaffolding erected between the North and South Courts in 1999 offers no support against sliding or bulging. Other interventions, such as gravity injection grouting, requires evaluation to determine new behavioral patterns resulting from seismic activity, lateral force and settlement of the rubble core.

5.4 Conclusions

Understanding historic conditions informs the gate's current state of deterioration. The 1950s excavation photographs indicate areas of compression and shear displacement resulting from the long history of additional loads placed on the Early Phrygian structure.

Because many of the conditions are products of historic conditions, understanding how the present environment affects the walls is critical to its preservation. The bulges and other displacements caused by compression and lateral force are highly susceptible to weathering and further displacement from the resultant open joints and cracks.

Interventions, such as the concrete cap and gravity injection grouting, provide some level of protection; however, they also increase certain vulnerabilities. Areas where detachment or cracking have emerged in the concrete cap enable water ingress and weathering of the core material. Cracks in the concrete also shift drainage patterns and can channel water toward the wall face. The water penetration into the core coupled with the injection grouting program increase the possibility of hydrostatic pressure within the wall.



Figure 40. The concrete cap has failed in areas and allowed water to penetrate the core.
By Wong, 2006.

Though the grouting process may have increased the stability of the rubble core and the bond of veneer and rubble core in the bottom courses of the northern and east elevations of the South Court, the upper courses maintain a certain level of vulnerability to weathering and settlement. The difference in strength between lower and upper courses must be evaluated and monitored for new patterns of displacements—particularly out-of-plane rotation, which could lead to toppling.

In general, the unexcavated, expansive clay construction fill inside the South Court walls threatens the structure's stability. Movement likely related to lateral pressure appears in both the east and north elevations and provides one of the few active mechanisms of displacement. Other active sources of displacement include ground movement. The comparison of historic and current images indicates the bulge in the northeastern elevation formed after excavation, and the movement observed during the 1999 Izmit earthquake confirms the ongoing displacement. The active conditions producing shearing, rotation and/or core settlement place the South Court walls at a higher risk for collapse.

In comparison, the North Court mainly exhibits localized areas of historic instability. Most serious conditions—bulging and compression or shear cracking—were visible at the time of excavation and relate to the considerable load applied by the former Middle Phrygian gate. Though the North Court demonstrates a higher degree of stability, the historic conditions must be monitored to detect any active displacements. Much of the current deterioration in the North Court results from water ingress at points of detachment or cracking in the concrete cap. The hollow areas indicate the weathering and settlement of the rubble core. A very serious condition in multiple leaf systems, weathering can lead to further bulging or failure by decreasing joint contact. Arresting water infiltration and implementing a monitoring program to identify the type of displacement and differentiate

between active and inactive conditions will more definitively confirm the cause/effect relationships contributing to the gate's instability.

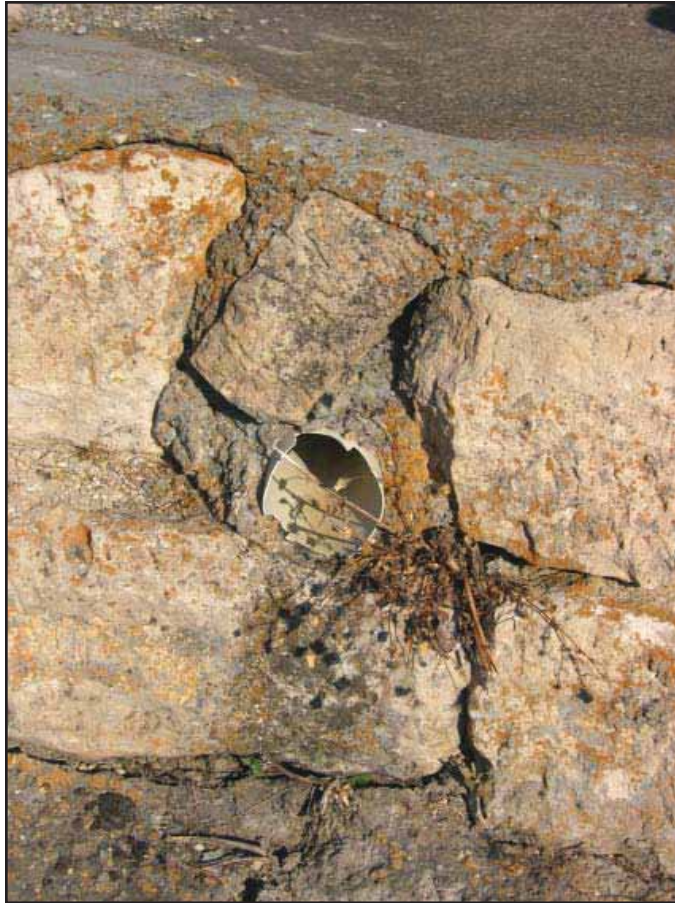

Figure 41. A drain in the cap directs water to areas of the wall, which then contributes to biogrowth. *By Wong, 2006.*

6.0 RECOMMENDATIONS FOR FUTURE TESTING AND MONITORING

Several recommendations will be offered to inform future investigations and conservation work on the Early Phrygian Gate. Based on the background research and condition assessment presented in this thesis, unknown elements pertaining to wall construction, stone properties and wall behavior have been identified and require further examination. In order to increase available knowledge and implement an effective conservation program for the gate complex, the following research should be conducted:

- Laboratory testing of stone and soil samples
- Structural monitoring
- Seismic modeling to predict structural behavior

The gate's vulnerabilities mainly relate to load distributions, weathering and seismic activity. The recommended areas of research will reduce or eliminate many of the current uncertainties concerning stone strength, material loss due to weathering, response to ground movement, structural behavior of grouted areas, displacement and soil-structure interaction.

6.1 Laboratory Testing

Determining the material properties of both stone and clay construction fill will

allow cause-effect relationships relating to weathering and stability to be established.

Though some correlations have been drawn by assuming certain properties—such as the expansive nature of the clay construction fill—testing will increase the amount of knowledge necessary to verify these relationships. Testing of the gate materials to ascertain porosity, density, elasticity and compressive strength (both wet and dry), will allow for the quantification of certain behavior. Because both limestone and rhyolite were used in the construction of the gate complex, data to quantify the properties of each stone is necessary.

The following tests should be conducted to determine material properties:

- Water absorption/desorption test
- Freeze/thaw test
- Compression and three-point bending tests of stone wet and dry, parallel and perpendicular to the rift
- Soil volume expansion
- Atterberg limits for the clay fill and any soil mortars

The general aging and weathering process alters material properties by increasing surface permeability, which accelerates weathering in stone. Weathered surfaces more quickly absorb moisture through the pores. Testing quantifies the rate of water absorption through capillarity, the rate of desorption (or evaporation) and also determines the volume of water contained within the material. These properties determine the material's susceptibility to water-related damage and also provide some indication of the degree of change possible in the stones' frictional properties. Because water decreases friction, testing should be conducted to ascertain the effect of water on stone cohesion and quantify the reduction of friction at the stone interface.

Understanding conditions contributing to material loss are critical in the gate's stability. The conditions relating to material loss which were recorded during the survey

included spalling and split faces. Though these conditions typically appear from the historic load patterns generated by the Middle Phrygian gate, the environmental conditions at Gordion present the necessary factors to contribute to material loss through freeze/thaw cycling. The ability to definitively attribute the spalls and split faces to a certain factor (whether environmental or structural) requires testing to establish 1) the extent of damage sustained by the limestone and rhyolite samples from freeze/thaw cycling and 2) the rate at which damage occurs.

Mechanical tests, such as three-point bending and compression, determine the elasticity and strength of the stones. The compression test will also verify differences in strength between rhyolite and limestone; ascertaining the strength and susceptibility to weathering of the two stones is critical in predicting their stability. Much of the compression cracks occur in the upper courses where the Middle Phrygian stones remain. Because rhyolite appears to be concentrated in these upper courses, it is important to understand the strength and mechanisms of deterioration relating to this specific stone.

Exposure to the environment over the past sixty years has increased the risks already threatening the gate's stability. When buried below several meters of construction fill, the stones remained relatively protected from moisture-related deterioration. Most risks related to strength of the individual stone units and the larger structure. Since being exposed to environmental conditions, the stones remain vulnerable to compressive loads in localized areas, but are also now subjected to mechanical and chemical weathering.

Additionally, the recent exposure has affected the clay construction fill and, as a result, provided a new risk to the gate's stability. When wet, the expansive red fan clays exert lateral force on the South Court walls due to their confinement within the interior court space. A soil volume expansion test should be conducted to calculate the degree of

expansion and amount of force applied to the walls. As indicated in the diagnosis, this soil-structure interaction presents the greatest threat to the stability of the South Court walls.

One important consideration relating to laboratory testing pertains to the properties of the Middle Phrygian courses which remain on portions of the Early Phrygian Gate walls. The relationship between the early and later stone courses must be investigated to determine relative weathering rates of the different materials. Water absorption/desorption and freeze/thaw testing should also be conducted on the Middle Phrygian stone to determine weathering rates. If the Early Phrygian rhyolite and limestone weather at a much greater rate, the material loss of the underlying stone will destabilize under the more constant load of the Middle Phrygian walls.

6.2 Monitoring Structural Changes

The diagnosis of current conditions serves as the basis for implementing a future monitoring program. Data collected from monitoring devices requires interpretation; however, effectively implementing the system and analyzing data will allow correlations between current conditions and their causes to be identified or confirmed. Though many conditions were found to be historic, monitoring in these areas is necessary to determine whether displacements remain active or have stabilized following excavation, which involved the large-scale removal of many Middle Phrygian walls and construction fill. Other areas requiring the implementation of a monitoring system include emerging or visibly active conditions, such as the bulge in the northeast elevation of the South Court, and areas which received injection grouting. The requirements of the monitoring device are location specific. However, general criteria necessary to determine the monitoring system include:

- Identify what needs to be measured
- Establish the range (or area) of the measurement

- Determine the resolution
- Identify where to position the device(s)
- Ascertain the accuracy required
- Ensure that the measurement is repeatable¹⁷¹

Identifying *what* is to be measured is the first step in implementing a monitoring system. Several factors affecting the gate's structural stability—displacement and material loss—require different monitoring programs. Also, multiple factors contributing to displacement in a single area may also necessitate the use of several devices to record type, direction and rate of movement. The complex history and construction of the Early Phrygian Gate have left the walls susceptible to multiple displacements. Out-of-plane and in-plane displacements produce movement in several directions. Because some devices are limited to a single plane of movement, areas such as the northeast corner of the South Court may require multiple devices to record both shearing action and bulging. Devices to measure erosion or other detectible material loss may be necessary for a more complete assessment of emerging or current structural instabilities, since material loss in the core affects settlement and, consequently, displacement of the veneer.

The range and resolution refer to specific factors related to the size of the measured area (in distance) and the increment of measurement needed to determine the type of device necessary to capture change. Dry stone structures experience very small, gradual displacements as the static friction inherent in the system periodically changes to a dynamic state. These brief transitions from static to dynamic friction can result in submillimeter displacements. However, areas within the multiple leaf system may experience larger movements, such as those recorded during seismic events or when the loss of material

¹⁷¹ Michael C. Henry. *Monitoring, Interpretation and Use of Data*. Tech. Los Angeles: J. Paul Getty Trust, 2003, 6.

within the rubble core causes larger settlements. A monitoring system must be capable of capturing the long-term, submillimeter and larger, seismically-induced movements to correlate cause with amount of movement.

Device placement is critical for obtaining the necessary data to confirm cause-effect relationships. Measuring movement at open joints, existing cracks and bulges typically provides information related to shear and localized out-of-plane displacements. Due to the complexity of behavior exhibited by bulging, an initial record of the contoured surface will inform later placement of devices. The preliminary mapping of the bulged surface offers an understanding of how movement occurs within the plane of the wall—whether it emerges as large-scale displacement of the entire veneer or localized movement of stones.

This type of preliminary mapping is specifically applicable to the large bulge in the northeast elevation of the South Court. The bulge displays signs of a general displacement of the veneer face (evident by the vertical stepped crack in the west return). Because multiple factors likely contribute to the movement of the veneer stones—lateral force from expansive clays, settlement of the core material and seismic activity—monitoring several locations will identify the main source (or sources) of displacement. High resolution systems should be placed at both center and edges of the bulge to measure the amount of thrust occurring in the center veneer stones and quantify detachment at the veneer face.

Rotation presents another measurable type of displacement noted at the site. Young observed the rotation of the North Court's southeast corner, which occurred from the disintegrated timber foundation. Measurements detecting change in the wall's angle will determine whether the historic movement remains active. Perhaps more threatening is the possible rotation due to the change in properties of the grouted walls. Though the degree of bonding remains unknown, it can be assumed that the grouting process increased

cohesion within the targeted areas. With a strengthened base, the lateral pressure exerted by the expansive clay backfill can cause a forward rotation of the entire wall. Additionally, measurements recording out-of-plane movement in the courses above the grouted region should also be considered.

Soil monitoring should supplement laboratory testing as a means to determine the soil-structure interaction. Measurements of moisture content within the clay backfill will provide data on the amount of moisture absorbed and retained within the clay. This data can be analyzed with the laboratory results to offer some indication of volume expansion and lateral force generated by the backfill. Another consideration relating to the soil-structure interaction is the decrease in friction produced by soil infiltrating joints or cracks within the veneer face and entering the rubble core. If excessive force from soil expansion is identified as the main factor contributing to displacement, consideration should be given to further archaeological excavation of the South Court interior to decrease lateral pressure.

As with any monitoring program, accuracy and repeatability are important components to ensure the efficacy of the system and its ability to determine causes and the degree of structural movement. Previous monitoring systems implemented at the gate complex include plumb lines and nails measured with a laser theodolite. These simple methods provide some data related to rotation and out-of-plane displacement, however, a more sophisticated system will be necessary to establish cause-effect relationships (particularly when multiple factors contribute to movement).

The types of measurements needed warrant more advanced devices in addition to the relatively simple and low-cost methods of analysis. However, it is important to note that though the low-cost systems already implemented have lower resolution and limited range, all monitoring devices maintain some source of error. High-cost monitoring technologies

do not guarantee accurate results, nor are they more easily repeatable. The use of multiple devices and methods—both high and low cost—reduces inherent error to record more accurate and repeatable measurements at the proper range and resolution.

Even with a program designed to measure various factors contributing to movement, limitations exist in using monitoring to delineate cause-effect relationships in multiple leaf structures. Several factors which produce similar conditions can be difficult to isolate. Because out-of-plane movement is attributed to both settlement of the weathered core material and lateral force exerted on the wall by the soil backfill, the source of movement is based on an assumption from collected and analyzed data. If displacement occurs during a period of soil saturation, the two events can be correlated; however, the much slower process of weathering and incremental displacement within the core cannot be excluded as a contributing factor, since this movement may also occur during periods of high precipitation.

The complexity of multiple leaf walls underscores the necessity for a more sophisticated monitoring program to understand the critical factors governing the gate's stability. Because failure in dry stone constructions is not well understood or predictable, the amount of displacement tolerated cannot be quantified. However, obtaining the rates of current displacements provides some indication of degree of stability and urgency of intervention to prevent collapse. Using monitoring systems to calculate the rate and causes of displacement will inform future conservation programs of the gate complex.

6.3 Modeling Seismic Behavior

Once general properties and long-term behavioral patterns are established through testing and monitoring, computer generated modeling for seismic behavior is recommended

to increase knowledge of structural movement caused by varying degrees of ground movement. Though the models contain various inaccuracies and require specific inputs relating to current conditions, construction, and magnitude of force, they illustrate general areas of vulnerability within a structure and serve as a basis for understanding the effects of past and future interventions.

As a particularly beneficial resource for predicting behavior of areas altered by injection grouting, modeling can demonstrate differences in response between grouted and ungrouted portions of the South Court walls. The limitations of modeling accuracy and unknown factors of wall construction must be considered when employing this method as a predictive tool. However, a simplified model of the wall will inform basic behavior, and general differences between grouted and ungrouted walls can be established. Variations of the simplified model can demonstrate changes in behavior caused by existing conditions, weathering, the influence of the soil backfill, magnitude of ground movement and differing levels of cohesion produced by injection grouting.

Modeling provides a valuable demonstration of the structure's response to possible future interventions. Other possible efforts, such as inserting tie rods to bond the veneer faces, should only be implemented after assessment with the available modeling technology. Because the conservation program at Gordion operates with the goal of minimal intervention, the ability to predict behavioral changes from structural modifications can eliminate inefficient methods of stabilization.

6.4 Further Research

Future research should focus on increasing knowledge of the gate construction, evaluating the performance of the grouting program and investigating alternatives to the

failing concrete cap. Though the basic construction of the gate is understood, the presence of some elements has been assumed, such as the use of wooden tie beams. The tying mechanism has been identified as a critical component in multiple leaf constructions, and although log through beams were discovered in the gate in 2003, their frequency and binding strength remains unknown. The high frequency of ties within a system greatly improves stability; non-destructive techniques to investigate the number and placement of the beams should be conducted and further research completed to assess the integrity of the beams. After confirming the number and integrity of the tie beams, a more accurate assessment of the gate's vulnerabilities can be established.

Other applications of nondestructive testing include the analysis of the grout injections. Testing to determine the amount of grout injected, its location within the wall and its bond strength will better support the accuracy of computer-generated modeling to predict seismic behavior. These factors related to the grouting program remain unknown but greatly affect the gate's performance when subjected to both ground movement and lateral force. Monitoring can determine the rate and direction of movement; however, the performance of the grouted system when subjected to seismic activity requires further assessment in order to predict displacement during an earthquake.

Because weathering presents a relatively high threat to the gate complex and correlations have been drawn between water ingress, material loss and localized instability, some level of intervention is necessary to remedy water permeation from the top of the structure. The effectiveness of the current concrete cap has been compromised by cracking and areas of detachment—possibly a result of thermal movement and wall displacement—which have allowed water to enter the rubble core. The current concrete cap also incorporates different (and relatively ineffective) drainage systems. Alternative drainage

should be considered to prevent runoff on the wall (which has supported biogrowth on the veneer stones) or in the core. Considerations for replacement must include material compatibility, weight of the capping material and durability in the Central Anatolian environment.

7.0 CONCLUSIONS

Dry stone multiple leaf buildings exhibit unique behavior under both normal and seismic conditions. Difficult to quantify, the unique characteristics demand alternative methods for evaluating stability. Understanding and analyzing these structures involves acquiring a detailed knowledge of construction techniques, material properties, site history and environmental conditions. As contributing factors to structural instability, these elements require some level of quantification to assess their impact on such precisely and skillfully balanced constructions.

Without the ability to calculate and wholly predict failure modes in dry stone structures, a thorough assessment of all known factors and present conditions delineates areas of weakness; this type of assessment also emphasizes limitations to the evaluative process. Identifying unknown aspects of construction and enabling factors proves just as important as understanding failure mechanisms. Though this research examines both inherent characteristics of dry stone construction and seismic behavior of multiple leaf walls, it identifies measures needed to determine structural stability and emerging failures.

Unknown elements exist at every site; however, these elements contribute the quantifiable data needed to establish cause-effect relationships of current conditions and should be thoroughly tested and measured. The information required to determine causality

is obtained through the following factors:

- Climate data
- Soil-structure interaction and general soil properties
- Wall construction and materials/components
- Repair history and changes in material properties and behavior
- History of the structure (noting any exceptional circumstances which may have altered performance, such as burial, fire, etc.)

Once understood, conditions resulting from weathering, external force and structural movements can be correlated to specific enabling factors. Because the moment of failure in dry stone constructions is relatively unpredictable, finding rates of change and types of displacement provide the data necessary to determine the level of intervention required. By isolating and reducing the deteriorative elements and monitoring critical structural displacement, possible failure mechanisms can be identified and preventive measures can be implemented.

BIBLIOGRAPHY

Books, Journal Articles, and Conference Proceedings

Addleson, L. *Building Failures: A Guide to Diagnosis, Remedy and Prevention*. Edition: 3rd ed. Publisher: Oxford ; Boston : Butterworth Architecture, 1992.

Adler, Isidore, Sheldon E. Sommer, Raphael Gershon, and Jacob I. Trombka. "Analytical Methods Related to Building and Monument Preservation." In *Conservation of Historic Stone Buildings and Monuments*. Report of the Committee on Conservation of Historic Stone Buildings and Monuments, 163–182. Washington, D.C.: National Academy Press, 1982.

Ainsworth, Mark, and L. Angela Mihai. "An Adaptive Multi-Scale Approach to the Modelling of Masonry Structures." *International Journal for Numerical Methods in Engineering* (2008).

Ashurst, John, and Francis G. Dimes, eds. *Conservation of Building and Decorative Stone*. Boston, MA: Butterworth-Heinemann, 1998.

Azevedo, J., and G. Sincaian. Modelling the Seismic Behaviour of Monumental Masonry Structures. Publication. 2000. UNESCO. 7 Feb. 2009 <www.unesco.org>.

Azevedo, Joao, Gabriela Sincaian, and J.V. Lemos. "Seismic Behavior of Blocky Masonry Structures." *Earthquake Spectra* 16 (2000): 337-65.

Betti, Michele, and Andrea Vignoli. "Modelling and Analysis of a Romanesque Church under Earthquake Loading: Assessment of Seismic Resistance." *Engineering Structures* 30 (2008): 352-67.

- Binda, L., A. Saisi, and C. Tiraboschi. "Investigation Procedures for the Diagnosis of Historic Masonries." *Construction and Building Materials* 14 (2000): 199-233.
- Binda, L., C. Modena, G. Baronio, and S. Abbaneo. "Repair and Investigation Techniques for Stone Masonry Walls." In *Construction and Building Materials*, Vol. 11, No. 3. Great Britain: Elsevier Science Ltd (1997): 133-142.
- Binda, L., G. Cardani and A. Saisi. "Performance of Some Repair and Strengthening Techniques Applied to Historical Stone Masonries in Seismic Areas." Proc. of ICPCM a New Era of Building, Cairo, Egypt, 18-20/2/2003, Vol. 2. 2003. 1195-1204.
- Binda, Luigia, and Antonella Saisi. "Research on Historic Structures in Seismic Areas in Italy." *Progress in Structural Engineering and Materials* 7 (2005): 71-85.
- Binda, Luigia, Mario Berra, Giulia Baronio and Alberto Fontana. "Repair of Masonries by Injection Technique: Effectiveness, Bond and Durability Problems." In *Structural Conservation of Stone Masonry. International Technical Conference*, Athens, 1989. Rome: ICCROM (1990), 431-441.
- Brady, K.C., and J. Kavanagh. *Analysis of the Stability of Masonry-Faced Earth Retaining Walls*. Rep. no. TRL550. TRL Limited, 2002.
- Bruneau, M. "Review of Structural Damage to Existing Buildings, and Seismic Rehabilitation Lessons from the 1989 Loma Prieta (San Francisco) Earthquake." In *Structural Repair and Maintenance of Historical Buildings II, Vol. 2: Dynamics, Stabilisation and Restoration: Proceedings of the Second International Conference*. Seville, Spain, 14-16 May 1991. Eds. C.A. Brebbia, J. Dominguez, F. Escrig. Southampton-Boston: Computational Mechanics Publications (1991): 89-100.
- Burgoyne, Sir John. "Revetments or Retaining Walls." *Papers on subjects connected with the duties of the Corps of Royal Engineers*. 3rd ed. Vol. 3. London: Royal Corps of Engineers, 1853. 154-59. *Hathi Trust Digital Library*. 20 Jan. 2009 <<http://hdl.handle.net/2027/wu.89073369290>>.
- Burland, J.B. and J.R. Standing. "Geotechnical Monitoring of Historic Monuments." *Geotechnical Engineering for the Preservation of Monuments and Historic Sites : Proceedings of the International Symposium, Naples, Italy, 3-4 October 1996*. Ed. C. Viggiani. Dallas: Taylor & Francis, 1997. 321-341.
- Celebi, Mehmet. *Engineering Implications of Ground Motions from the 1999 Turkey Earthquakes*.

Tech. Public Works Research Institute. 2000. 3 Feb. 2009_<<http://www.pwri.go.jp/eng/ujnr/tc/a/wsssi/pdf/s05.pdf>>.

Cooper, M.R.. “Deflections and Failure Modes in Dry-Stone Retaining Walls.” *Ground Engineering*, 19:8, 1986, 28-33. and S. Osmond. “A Survey of Failed Free-Standing Walls.” *Proceedings of the Third International Masonry Conference*. 6th ed. Vol. 3rd Proc. British Masonry Society, 1994. 87-90.

Cundall, P.A., and O.D.L. Strack. “A Discrete Numerical Model for Granular Assemblies.” *Geotechnique* 29 (1979): 47-65.

D’Asdia, P. “Analysis of the Seismic Response of Masonry Structures.” *Structural Preservation of the Architectural Heritage*. Proc. of IABSE Symposium Rome. Vol. 70. Italy: IABSE, 1993. 281-288.

Delgado Rodrigues, J. “Dry-Stone Wall Monuments – Structural Behavior, Disturbing Mechanisms and Conservation Procedures.” In *Engineering Geology of Ancient Works, Monuments and Historical Sites*. Marinos and Koukis, eds. Rotterdam: Balkema, 1988, 1001-1006.

Demonstenous, M. and G. C. Manos. “Dynamic Response of Models Subjected to Horizontal Motions.” *Structural Preservation of the Architectural Heritage*. Proc. of IABSE Symposium Rome. Vol. 70. Italy: IABSE, 1993. 361-368.

Devries, Keith. “The Gordion Excavation Seasons of 1969-1973 and Subsequent Research.” *American Journal of Archaeology*, Vol. 94, No. 3. (July 1990), 371-406.

Dickens, J.G. and P.J. Walker. “Correlation of Structural Movements with Joint Characteristics on Dry-Stone Walls.” In *Structural Repair and Maintenance of Historical Buildings IV*, Vol. 1: Architectural Studies, Materials and Analysis. Proceedings of the 4th International Conference, Chania, Crete, 22 - 24 May 1995, Brebbia & Leftheris (Ed.). Southampton: Computational Mechanics, 1995, 357-364.

El Samny, M.K. “Structural Response during the 1992 Cairo Earthquake.” *10th European Conference on Earthquake Engineering*. Austria, Vienna. Vol. 1. Brookfield: Balkema, 1995. 793-798.

Erberik, M. Altug. “Generation of Fragility Curves for Turkish Masonry Buildings Considering In-Plane Failure Modes.” *Earthquake Engineering and Structural Dynamics* 37 (2008): 387-405.

- Erdik, M. "The Earthquake Performance of Rural Stone Masonry Buildings in Turkey." *Earthquake Damage Evaluation and Vulnerability Analysis of Building Structures*. Oxford: Omega Scientific, 1990. 57-77.
- Forsyth, Michael, ed. *Structures and Construction in Historic Building Conservation*. New York: John Wiley & Sons, Incorporated, 2007.
- Gavrilovic, Predrag, Veronika Sendova, Lazar Sumanov, and William Ginell. *Conservation and Seismic Strengthening of Byzantine Churches in Macedonia*. Los Angeles, CA: Getty Publications, 2004.
- Gil, N., and C.S. Oliveira. "A Preliminary Study on the Seismic Behaviour of the Church of Convento do Carmo in Lisbon and Its Confrontation with the Historical Perspective." *Structural Studies, Repairs and Maintenance of Historical Buildings IV*. Vol. 1. WIT P, 1995. 311-316.
- Goodman, Mark. "Architectural Conservation at Gordion." In *The Archaeology of Midas and the Phrygians*, 215-229. Ed. Lisa Kealhofer. Philadelphia: The University Museum, University of Pennsylvania, 2005. Kealhofer, Lisa, ed. *The Archaeology of Midas and the Phrygians*. Philadelphia: The University Museum, University of Pennsylvania, 2005.
- Gudehus, G. "Geotechnical Protection of Historical Retaining Walls and Shallow Foundations." *The Engineering Geology of Ancient Works, Monuments and Historical Sites*, Rotterdam: Balkema. Marinos & Koukis Eds., 1990, 1957-1964.
- Harkness, R.M., W. Powrie, X. Zhang, K.C. Brady and M.P. O'Reilly. "Numerical Modelling of Full-Scale Tests on Drystone Masonry Retaining Walls." *Geotechnique*. 50:2. 165-179.
- Henry, Michael C. *Monitoring, Interpretation and Use of Data*. Tech. Los Angeles: J. Paul Getty Trust, 2003.
- Karaesmen, Engin and Erhan Karaesmen. "A Study of the Structural Behaviour of Historic Masonry Buildings in Seismic Zones." *10th European Conference on Earthquake Engineering*. Austria, Vienna. Vol. 2. Brookfield: Balkema, 1995. 927-933.
- Karantoni, F.V., M.N. Fardis, and D. Matraka. "Comparative Study of the Seismic Response of Stone and Brick Masonry Buildings." *Structural Studies, Repairs and Maintenance of Historical Buildings IV*. Vol. 2. WIT P, 1995. 61-68.

- Kealhofer, Lisa. *The Archaeology Of Midas And The Phrygians Recent Work At Gordion*. New York: University of Pennsylvania Museum Publication, 2005.
- Kourkoulis, Stavros K. *Fracture and Failure of Natural Building Stones*. New York: Springer, 2006.
- Langenbach, R. "Learning from the Past: Traditional and Contemporary Unreinforced Masonry in Seismic Areas." *Structural Conservation of Stone Masonry*. Greece, Athens. Rome: ICCROM, 1990. 343-354.
- Langenbach, Randolph. "Survivors among the Ruins: Traditional Houses in Earthquakes in Turkey and India." *APT Bulletin* 33 (2002): 47-56. *JSTOR*. 1 Nov. 2008 <<http://www.jstor.org/stable/1504756>>.
- Lemos, J.V. "Modeling Stone Masonry Dynamics with 3DEC." Ed. Heinz Konietzky. *Numerical Modeling of Discrete Materials in Geotechnical Engineering, Civil Engineering, & Earth Sciences*. Dallas: Taylor & Francis, 2004. 7-13.
- Lilley, D.M.; March, A.V. "Problems in Rubble-Filled Random Masonry Walls." In *International series on Advances in Architecture, vol. 3: Structural Studies, Repairs and Maintenance of Historical Buildings*, eds. S. Sánchez-Beitia and C.A. Brebbia, Southampton, UK; Boston: Computational Mechanics Publications (1997): 417-426.
- Lourenco, P.B., and J.A. Roque. "Simplified Indexes for the Seismic Vulnerability of Ancient Masonry Buildings." *Construction and Building Materials* 20 (2006): 200-08. ScienceDirect. University of Pennsylvania, Philadelphia.
- Lourenco, Paulo B. "Computations on Historic Masonry Structures." *Progress in Structural Engineering and Materials* 4 (2002): 301-19.
- Lourenco, Paulo B., Luis F. Ramos, and Garca Vasconcelos. "On the Cyclic Behaviour of Stone Dry Masonry Joints." Proc. of Thirteenth International Brick and Block Masonry Conference, Amsterdam, 2004.
- Maekawa, Shin, and Neville H. Agnew. "Investigations of Environmentally Driven Deterioration of the Great Sphinx and Concepts for Protection." In Ashok Roy and Perry Smith, eds., *Archaeological Conservation and Its Consequences*. Preprints of the Contributions to the Copenhagen Congress. London: International Institute for Conservation of Historic and Artistic Works (IIC), (26-30 August 1996): 116–120.

- Marco, Shmuel. "Recognition of Earthquake-Related Damage in Archaeological Sites: Examples from the Dead Sea Fault Zone." *Tectonophysics* 453 (2008): 148-156.
- Marsh, Ben. "Alluvial Burial of Gordion, an Iron-Age City in Anatolia." *Journal of Field Archaeology* 26 (1999): 163-75. *JSTOR*. University of Pennsylvania. 9 Feb. 2009.
- Marsh, Ben. "Physical Geography, Land Use, and Human Impact at Gordion." *The Archaeology Of Midas And The Phrygians: Recent Work At Gordion*. Ed. Lisa Kealhofer. New York: University of Pennsylvania Museum Publication, 2005
- Maugeri, M., G. Muscolino and G. Pracanica. "Seismic Response Analysis of Historical Buildings." *Geotechnical Engineering for the Preservation of Monuments and Historic Sites: Proceedings of the International Symposium, Naples, Italy, 3-4 October 1996*. Ed. C. Viggiani. Dallas: Taylor & Francis, 1997. 225-238.
- Meyer, Patrik, John Ochsendorf, John Germaine, and Eduardo Kausel. "The Impact of High-Frequency/Low-Energy Seismic Waves on Unreinforced Masonry." *Earthquake Spectra* 23 (2007): 77-94.
- Meyer, Patrik K. "The Impact of High Frequency/Low Energy Seismic Waves on Unreinforced Masonry." Thesis. MIT, 2006. <http://web.mit.edu/masonry/index.html>. June 2006. MIT. 7 Feb. 2009 <www.mit.edu>.
- Mistler, M., C. Butenweg, and K. Meskouris. "Modelling Methods of Historic Masonry Buildings under Seismic Excitation." *Journal of Seismology* 10 (2006): 497-510.
- Mouzakis, H.P., I.N. Psycharis, D.Y. Papastamatiou, P.G. Carydis, C. Papantonopoulos, and C. Zambas. "Experimental Investigation of the Earthquake Response of a Model of a Marble Classical Column." *Earthquake Engineering and Structural Dynamics* 31 (2002): 1681-698.
- Mundell, Chris, John Harkness, and Pete Walker. "Large Scale Testing of Drystone Retaining Walls." Proc. of Structural Analysis of Historic Construction, England, Bath. London: Taylor & Francis Group, 2008. 781-87.
- Ndoro, Webber. "Restoration of Dry-Stone Walls at the Great Zimbabwe." Archaeological Site. *Conservation and Management of Archaeological Sites* 1.2 (1995): 87-96.
- Osmond, S. "A Survey of Failed Free-Standing Walls." *Proceedings of the Third International Masonry Conference*. 6th ed. Vol. 3rd Proc. British Masonry Society, 1994. 87-90.

- Pagnoni, T. "Seismic Analysis of Masonry and Block Structures with Discrete Element Method." *10th European Conference on Earthquake Engineering*. Austria, Vienna. Vol. 3. Brookfield: Balkema, 1995. 1669-1674.
- Penazzi, D.; Valluzzi, M.R.; Saisi, A.; Binda, L.; Modena, C. "Repair and Strengthening of Historic Masonry Buildings in Seismic Areas." (from the UNESCO website: www.unesco.org/archi2000/pdf/bindal197.pdf)
- Powrie, W., R. M. Harkness, X. Zhang, and D. I. Bush. "Deformation and Failure Modes of Drystone Retaining Walls." *Geotechnique*. 52:6, 2002, 435-446.
- Psycharis, I.N., J.V. Lemos, D.Y. Papastamatiou, C. Zambas, and C. Papantonopoulos. "Numerical Study of the Seismic Behaviour of a Part of the Parthenon Pronaos." *Earthquake Engineering and Structural Dynamics* 32 (2003): 2063-084.
- Rodrigues, J. Delgado. "Dry-Stone Wall Monuments: Structural Behavior, Disturbing Mechanisms and Conservation Procedures." In Paul G. Marinos and George C. Koukis (eds), *Engineering Geology of Ancient Works, Monuments and Historical Sites*, 2, 1001–1006. Rotterdam: A.A. Balkema, 1988.
- Schuller, M.P., R.H. Atkinson, and J.L. Noland. "Evaluation of Historic Masonry Buildings." *APT Bulletin* 26 (1995): 51-61.
- Sensoy, Serhat. "Climate of Turkey." *Climate of Turkey*. 2007. Devlet Meteoroloji İşleri Genel Müdürlüğü. 13 Feb. 2009 <<http://www.dmi.gov.tr/index.aspx>>.
- Shahinian, Sarkis. "Conservation of Monuments in Natural Stone in Earthquake Zones: Reversibility as an Intervention Strategy." *Structural Studies, Repairs and Maintenance of Historical Buildings VI*. Southampton: WIT P, 1999. 259-68.
- Simonelli, A.L. "Earth Retaining Wall Displacement Analysis under Seismic Conditions." *10th European Conference on Earthquake Engineering*. Austria, Vienna. Vol. 1. Brookfield: Balkema, 1995. 545- 550.
- Structural Conservation of Stone Masonry*. Proc. of International Technical Conference, Athens, Greece. Rome: ICCROM, 1990.
- Tomazevic, Miha. "Laboratory and In Situ Tests of the Efficacy of Grouting and Tying of Stone Masonry Walls." *International Workshop CNR-GNDT*. Proc. of Effectiveness of Injection Techniques for Retrofitting of Stone and Brick Masonry Walls in Seismic

Areas, Italy, Milan. Ed. L. Binda. 95-116.

USGS. *Implications for Earthquake Risk Reduction in the United States from the Kocaeli, Turkey Earthquake of August 17, 1999*. Publication no. 1193. US Department of the Interior, 2000.

Vasconcelos, Graca, and Paulo B. Lourenco. "Evaluation of the In-Plane Seismic Performance of Stone Masonry Walls." 2005. *Repositorium*. Universidade do Minho. 7 Feb. 2009 <<http://repositorium.sdum.uminho.pt>>.

Walker, P.J. and J.G. Dickens. *An Engineering Study of Dry-Stone Monuments in Zimbabwe*. Vol. 1. Loughborough: Loughborough University of Technology, 1992.

Walker, P.J. and J.G. Dickens. "Intervention Techniques in the Conservation of Dry-Stone Structures." *Conservation of Stone and Other Materials*. M. J. Thiel, ed. London: E&FN Spon, Vol. 2, 1993, 452-459.

Watabe, M., H. Aoki, T. Hanasato. "Earthquake Resistant Capacity of the Parthenon." *Structural Preservation of the Architectural Heritage*. Proc. of IABSE Symposium Rome. Vol. 70. Italy: IABSE, 1993. 345-352.

Wehr, W. "Stabilisation of Retaining Walls with Non-Grouted Soil Nails." *Ground Improvement* 7.4 (2003): 173-176.

Wong, Kelly H. *Assessment of the Grout Used for the Structural Stabilization of the Early Phrygian Citadel Gate at Gordion, Turkey*. Philadelphia, PA: UPenn, 2006.

Young, Rodney S. "The Phrygian Contribution." In *Proceedings of the Xth International Congress of Classical Archaeology (1973)*. Ankara (1978).

Young, Rodney S. "Gordion Preliminary Report – 1953." *American Journal of Archaeology* (1955) 59: 1-18.

Young, Rodney S. "The Campaign of 1955 at Gordion." *American Journal of Archaeology* (1956) 60: 249-266.

Young, Rodney S. "Discoveries at Gordion – 1956." *Archaeology* (1956) 9: 2463-267.

Young, Rodney S. "Gordion 1956." *American Journal of Archaeology* (1957) 61: 319-331.

- Young, Rodney S. "The Gordion Campaign of 1957." *American Journal of Archaeology* (1958) 62: 139-154.
- Young, Rodney S. "The Gordion Campaign of 1959: Preliminary Report." *American Journal of Archaeology* (1960) 64: 227-243.
- Young, Rodney S. "Gordion: Phrygian Construction and Architecture." *Expedition 2* (1960) 2: 2-9.
- Young, Rodney S. "The 1961 Campaign at Gordion." *American Journal of Archaeology* (1962) 66: 153-168.
- Young, Rodney S. "Phrygian Construction and Architecture II." *Expedition 4* (1962) 4: 2-12.
- Young, Rodney S. "The 1963 Campaign at Gordion." *American Journal of Archaeology* (1964) 68: 279-292.
- Young, Rodney S. "The Gordion Campaign of 1965." *American Journal of Archaeology* (1966) 70: 267-278.
- Young, Rodney S. "The Gordion Campaign of 1967." *American Journal of Archaeology* (1968) 72: 231-242.
- Zilch, K., D. Schermer, and W. Scheufler. *Simulated Earthquake Behavior of Unreinforced Masonry Walls*. Publication. Technische Universitat Munchen. 7 Feb. 2009_<www.mb.bv.tum.de>.
- Unpublished Material*
- Cleary, Sarah and Kelly Wong. *Site Field Report*. Gordion Excavation Project, 2007.
- Goodman, Mark. *Architectural Conservation at Gordion: Summer 1999*. Gordion Excavation Project 1999.
- Goodman, Mark M. *Site Conservation at Gordion: Summer 2003*. Gordion Excavation Project, 2003.
- Matero, Frank. *Field Report, Gordion Excavation, Turkey*. Philadelphia: University of Pennsylvania, School of Design, Architectural Conservation Laboratory. July 5,

2005.

Rogers, Mark H. *Site Conservation at Phrygian Gordion*. Honors Thesis. University of North Carolina at Chapel Hill, Department of Art. 1989.

Wong, Kelly. *Dossier: Citadel Gate Complex*. Philadelphia: University of Pennsylvania, School of Design, Architectural Conservation Laboratory. Summer 2006.

Wong, Kelly. *Early Phrygian Citadel Gate: 2006 Treatment Report*. Gordion Excavation Project, 2006.

Wong, Kelly. *Field Notebook: Gordion Architectural Conservation Citadel Gate 2006 Season*. Philadelphia: University of Pennsylvania, School of Design, Architectural Conservation Laboratory. 2006.

Archival Collections

University of Pennsylvania Museum of Archaeology & Anthropology, Gordion Archives,
Philadelphia, Pennsylvania
Photographs, Slides, Maps, Notebooks and Journal Articles (Publications)

Drawings of Gordion, Turkey Site

2002. Yassihöyük/Gordion Citadel Mound (plan showing excavation areas in 1900-1972 and 1988-2002) by Carrie Alblinger.

2004. Yassihöyük/Gordion Early Phrygian Period YHSS 6A (plan showing excavated building footprints) by Carrie Alblinger.

2004. Yassihöyük/Gordion Early Phrygian Destruction Level YHSS 6A (plan showing areas under construction, drains, and limits of excavation) by Carrie Alblinger.

2004. Yassihöyük/Gordion Middle Phrygian Period YHSS 5 (plan showing excavated building footprints) by Carrie Alblinger.

Other Media

Devlet Meteoroloji İşleri Genel Müdürlüğü. 13 Feb. 2009 <<http://www.meteor.gov.tr/2006/english/eng-climateofturkey.aspx>>.

“Eurocodes 8 Earthquake.” *Welcome to Eurocodes*. 01 Mar. 2009 <<http://www.eurocodes.co.uk/EurocodeDetail.aspx?Eurocode=8>>.

“Masonry and Historical Constructions Group.” *Departamento de Engenharia Civil Universidade do Minho*. 01 Mar. 2009 <<http://www.civil.uminho.pt/masonry/>>.

“Masonry Research at MIT.” *MIT*. 23 Jan. 2009 <<http://web.mit.edu/masonry/index.html>>.

Lehrstuhl für Baustatik und Baudynamik. 01 Mar. 2009 <http://www.baustatik.rwth-aachen.de/index.php?page=Home_Region&>.

APPENDIX A

CONDITION DRAWINGS

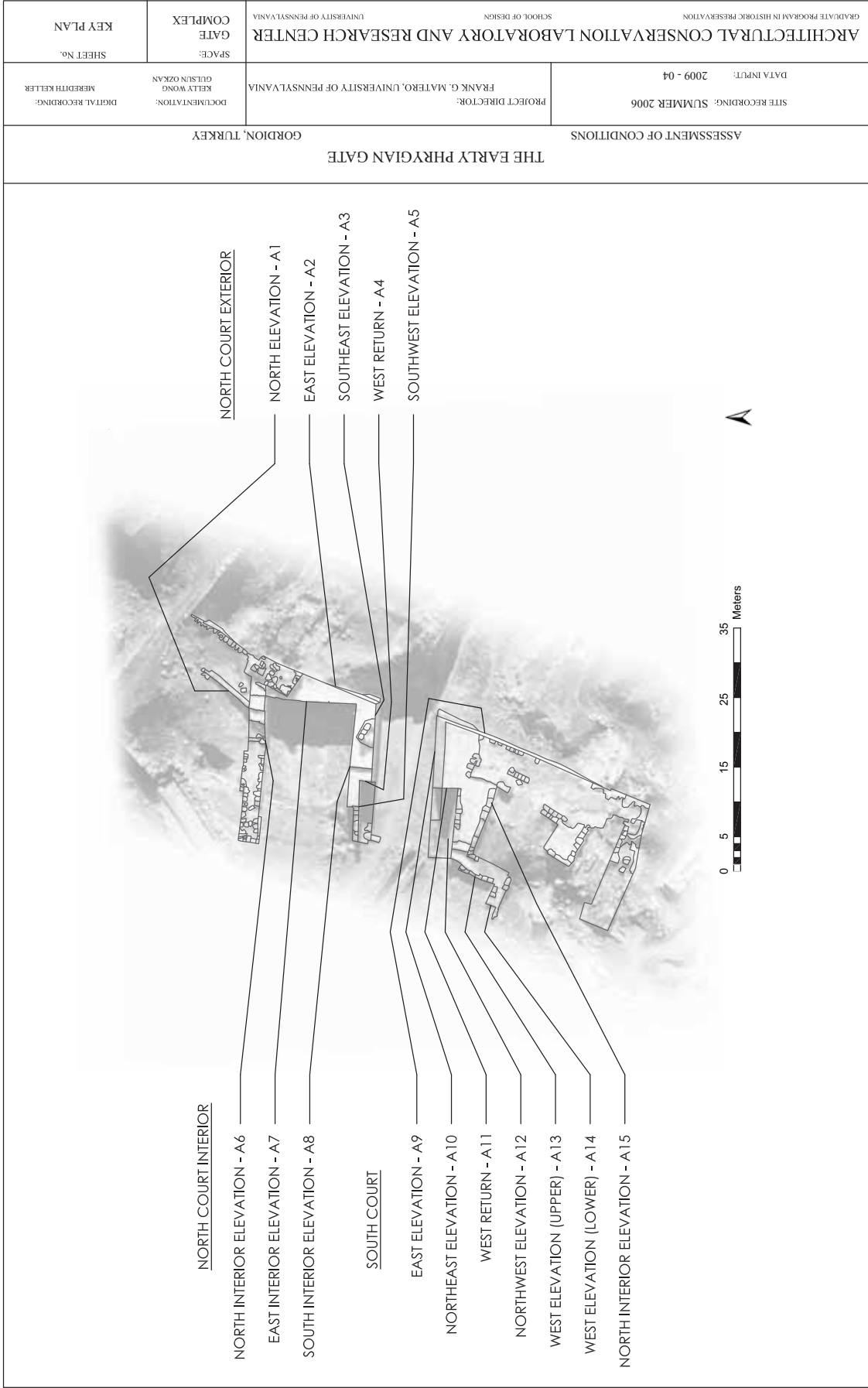

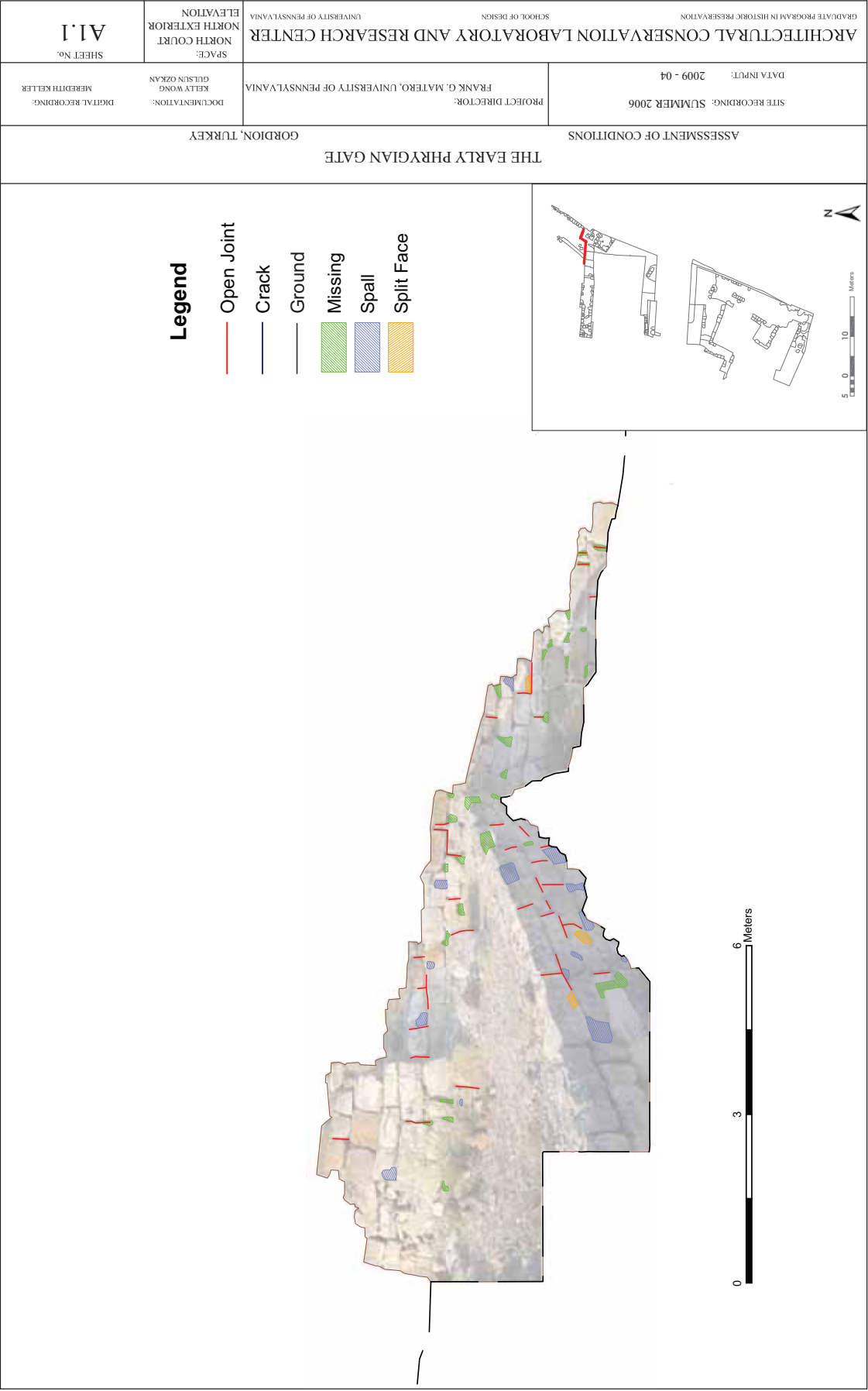

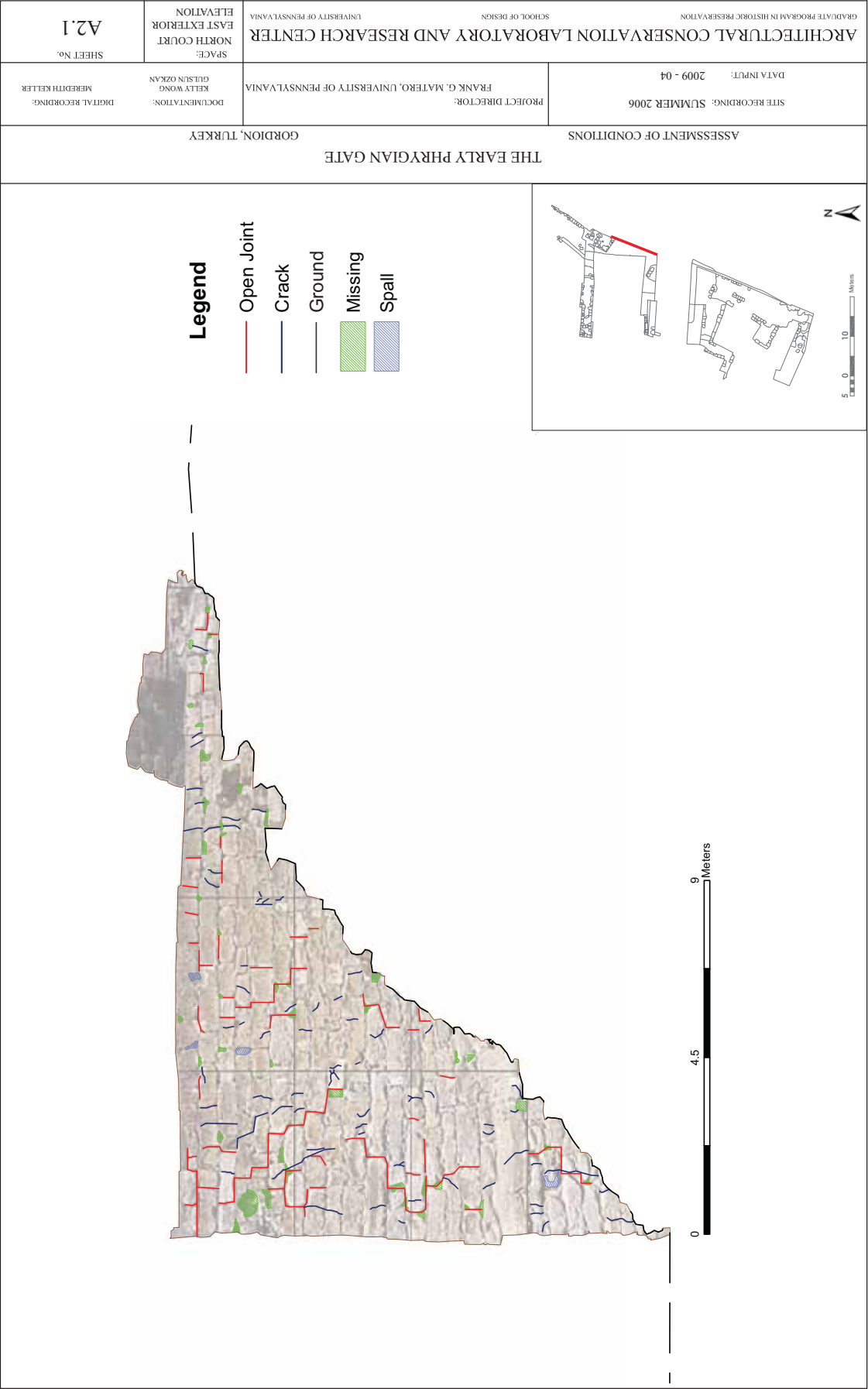

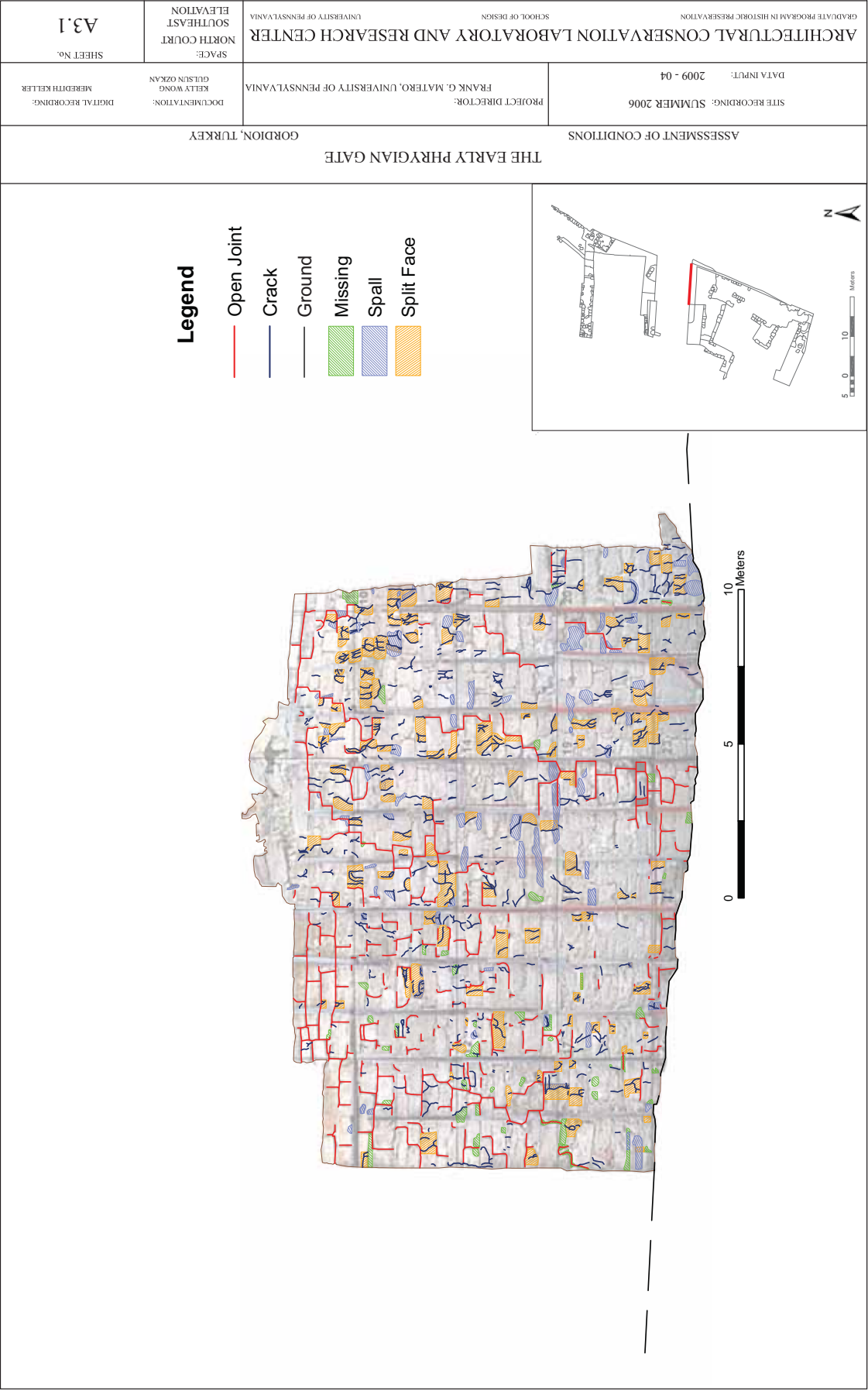



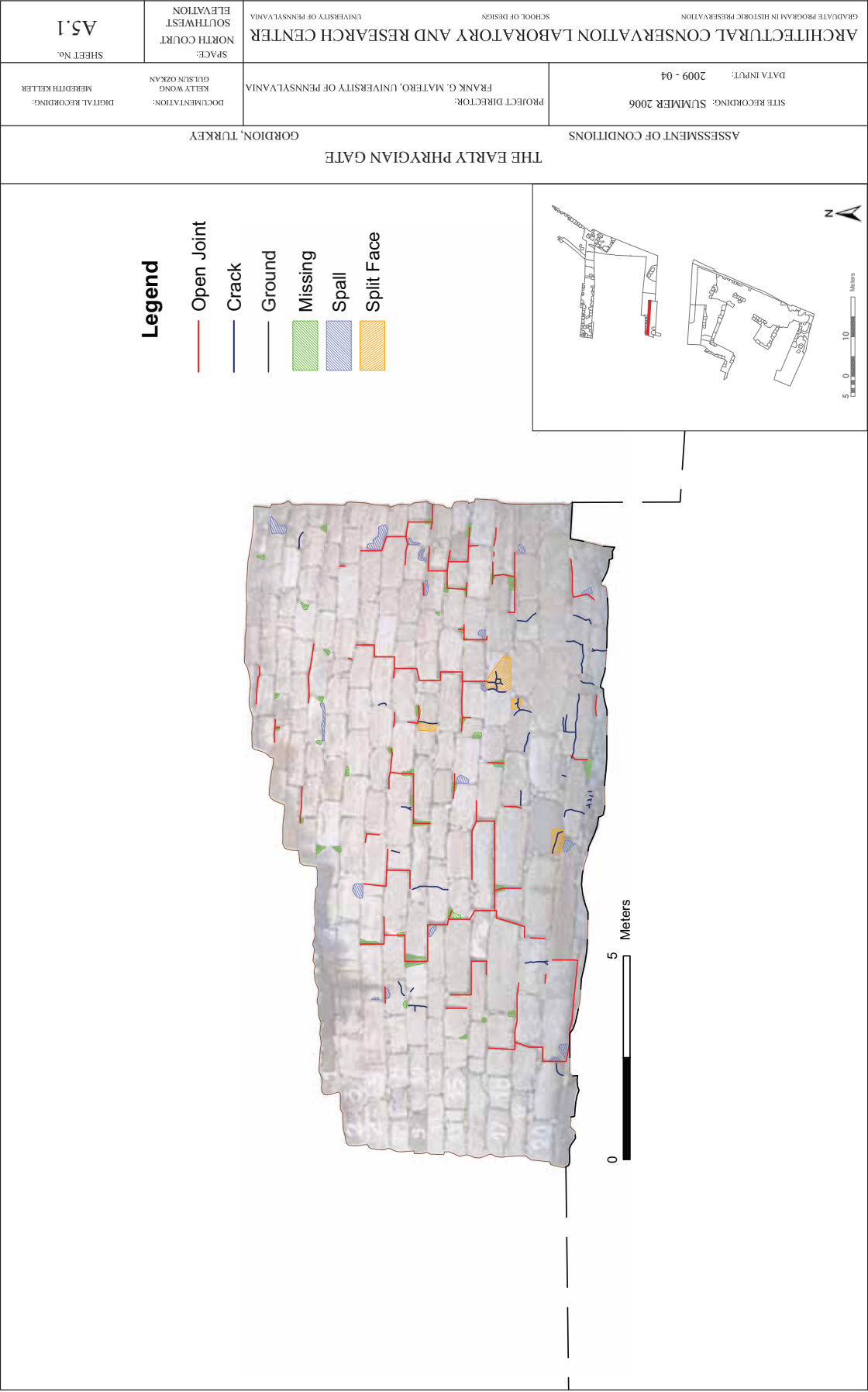

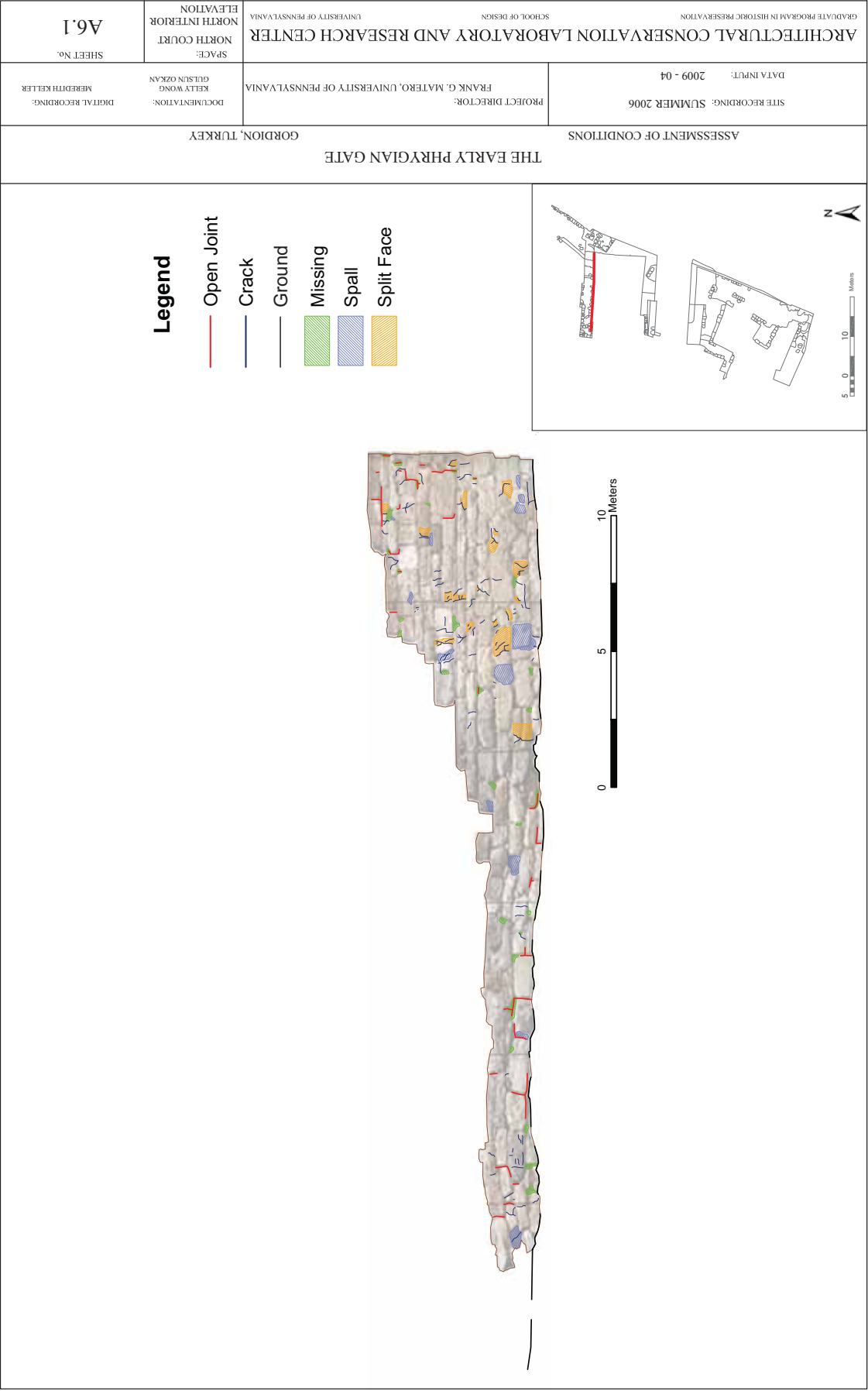



ASSESSMENT OF CONDITIONS
THE EARLY PHRYGIAN GATE
GORDION, TURKEY

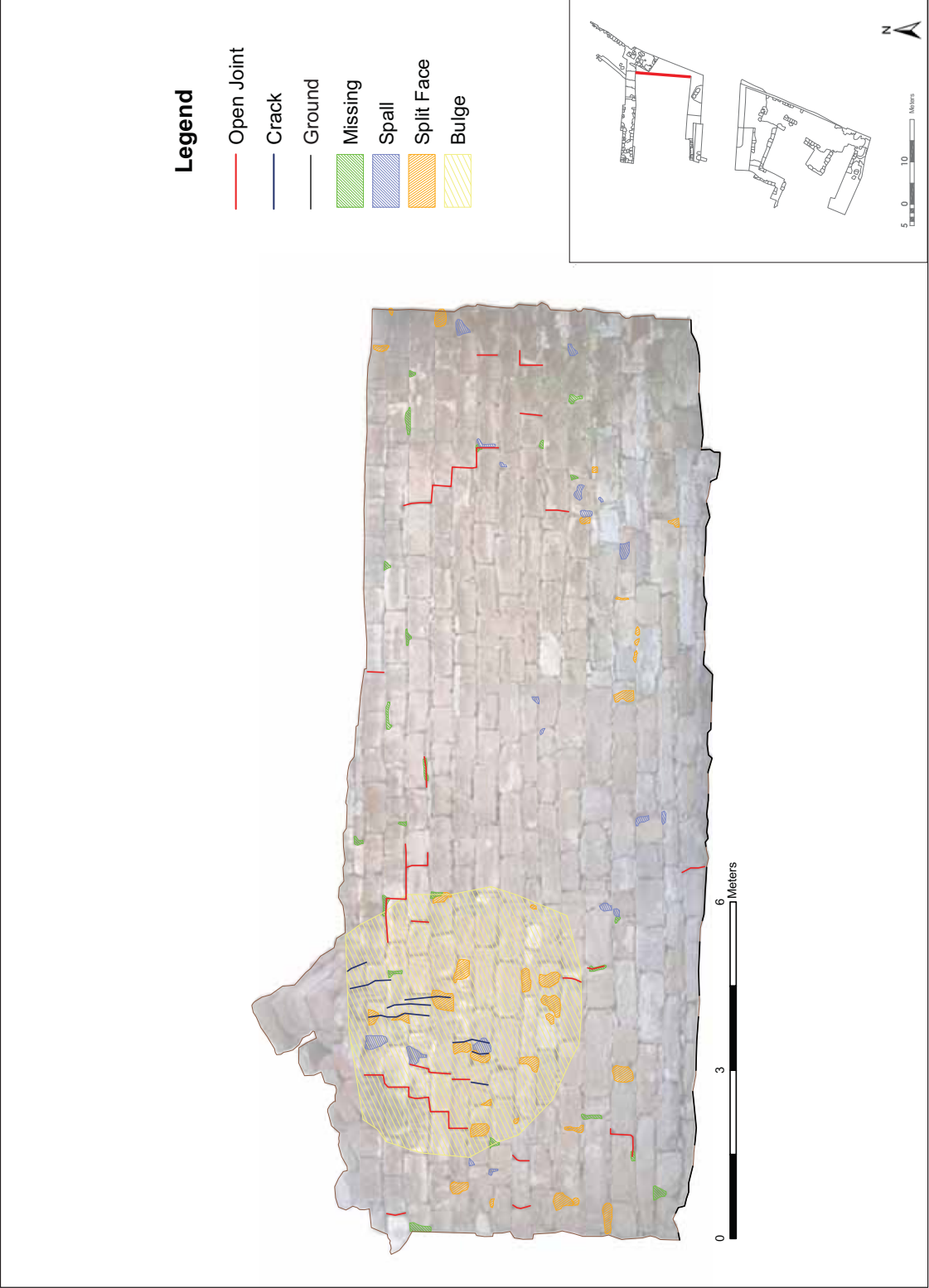



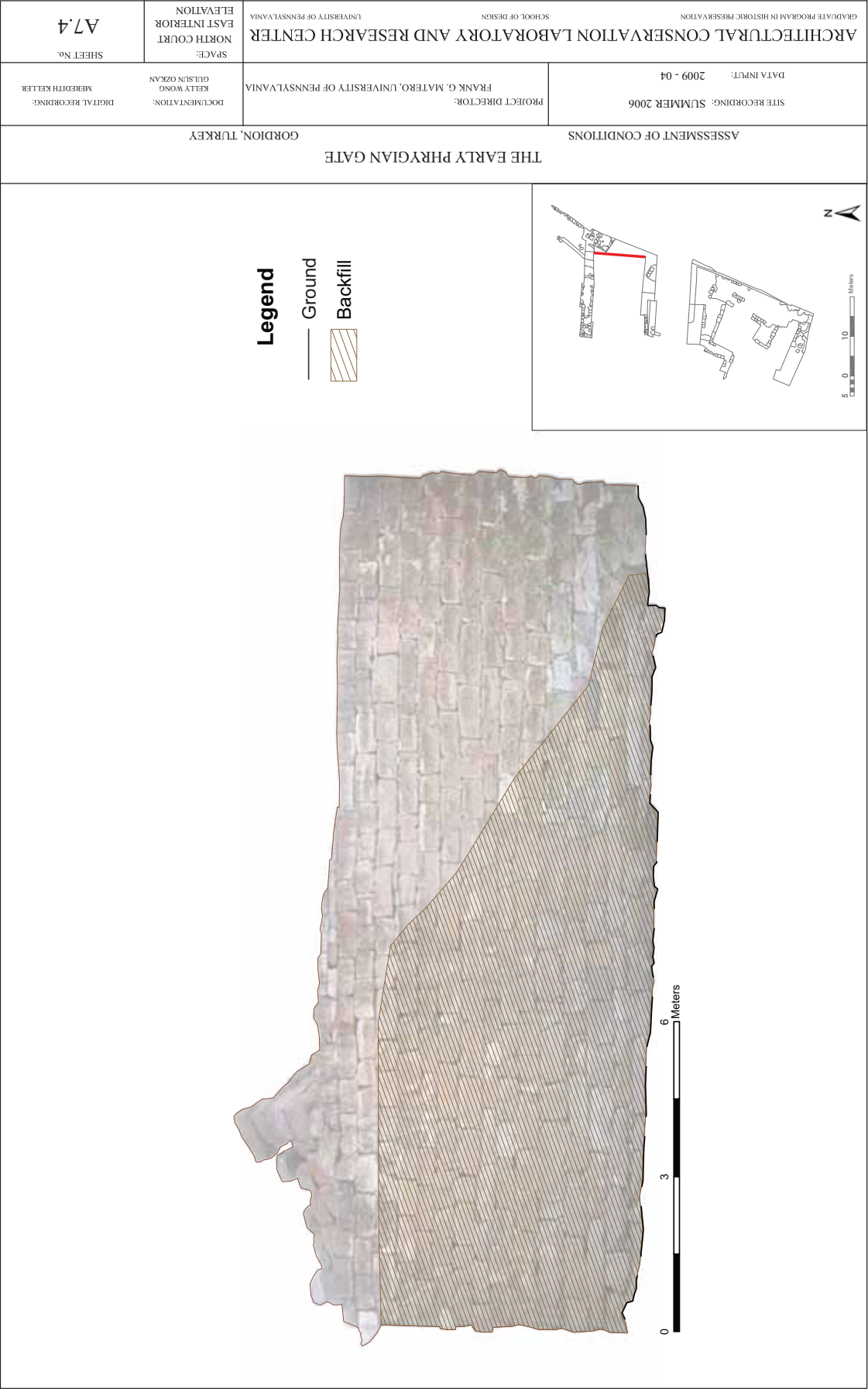

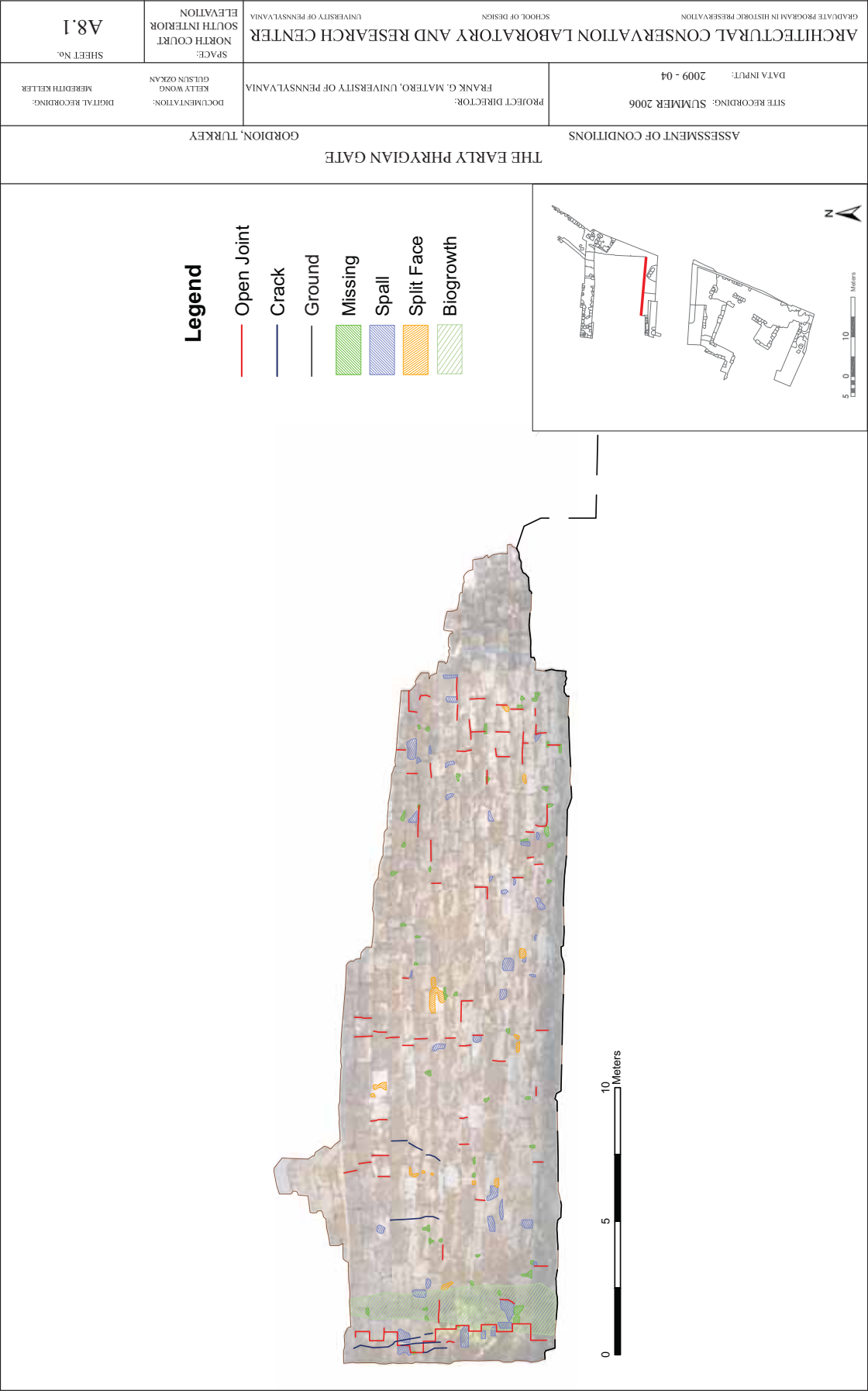

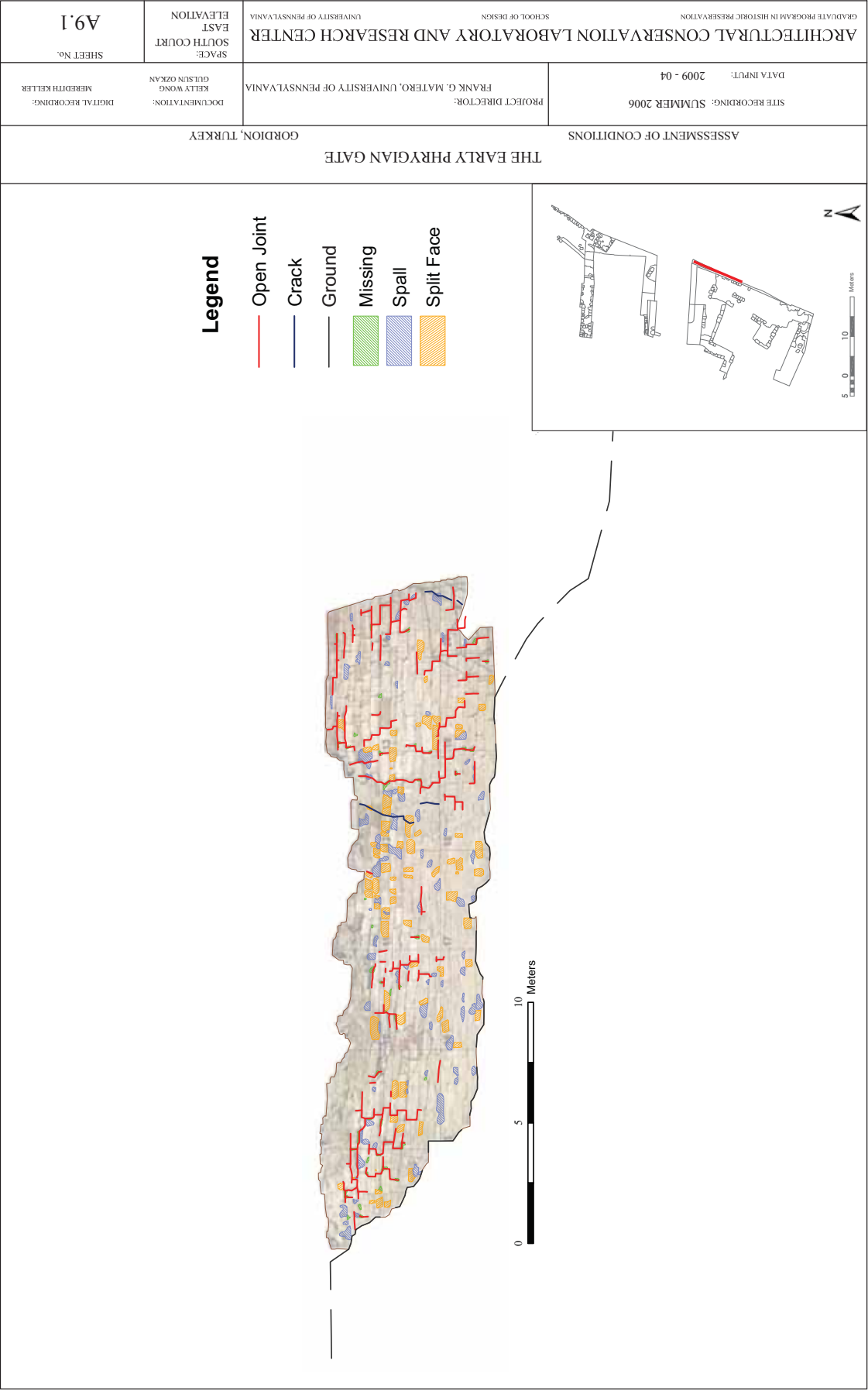

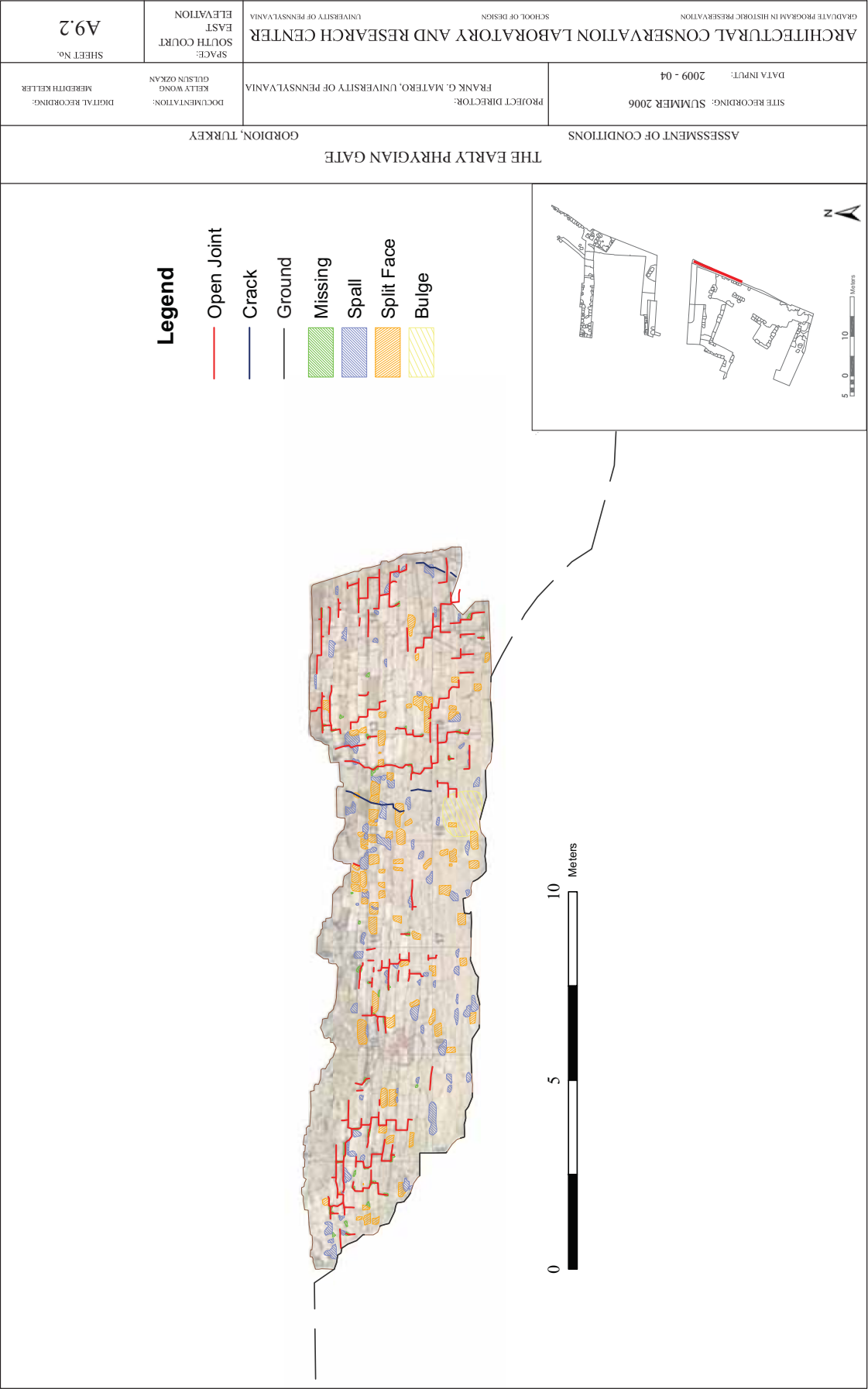

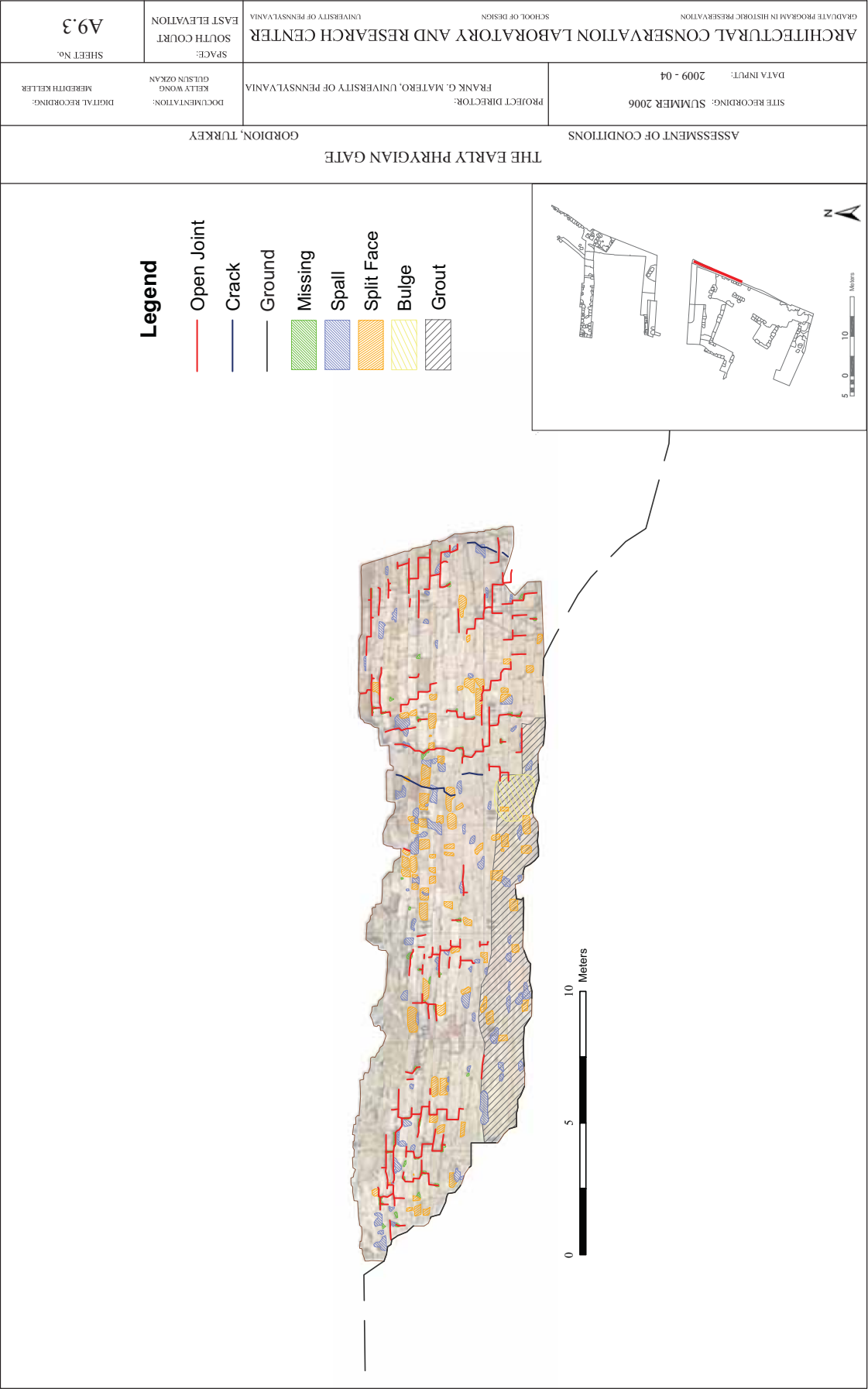

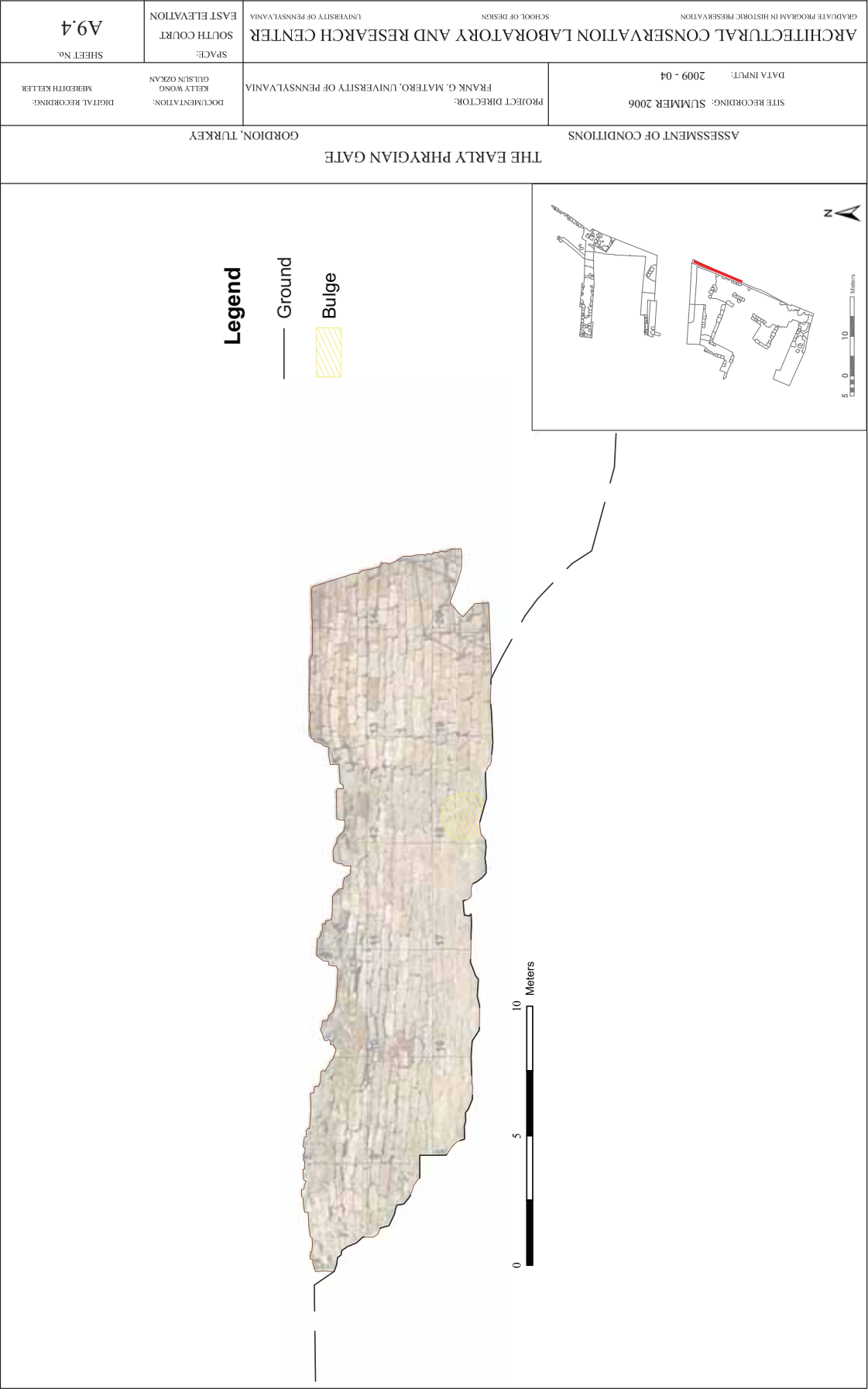

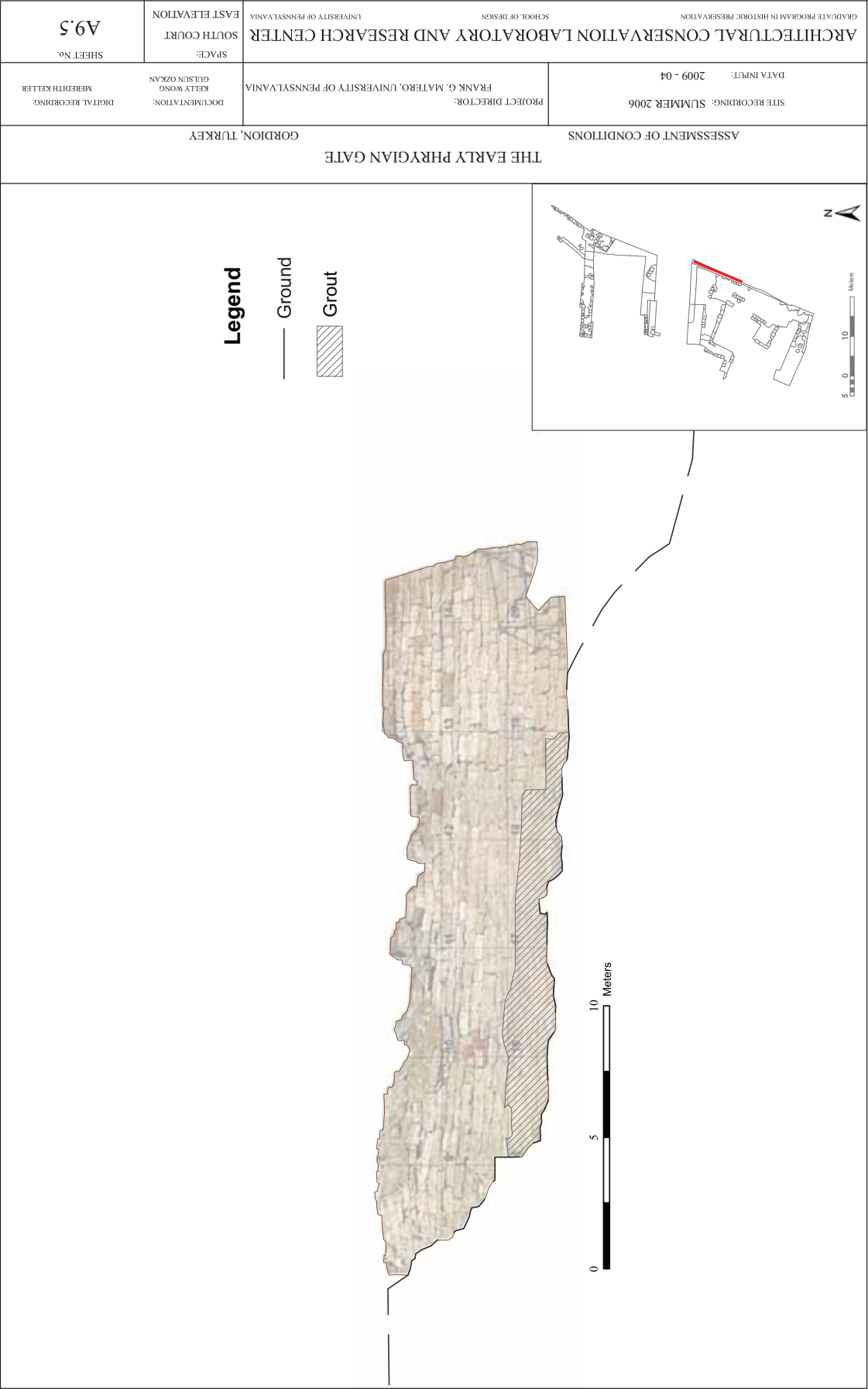

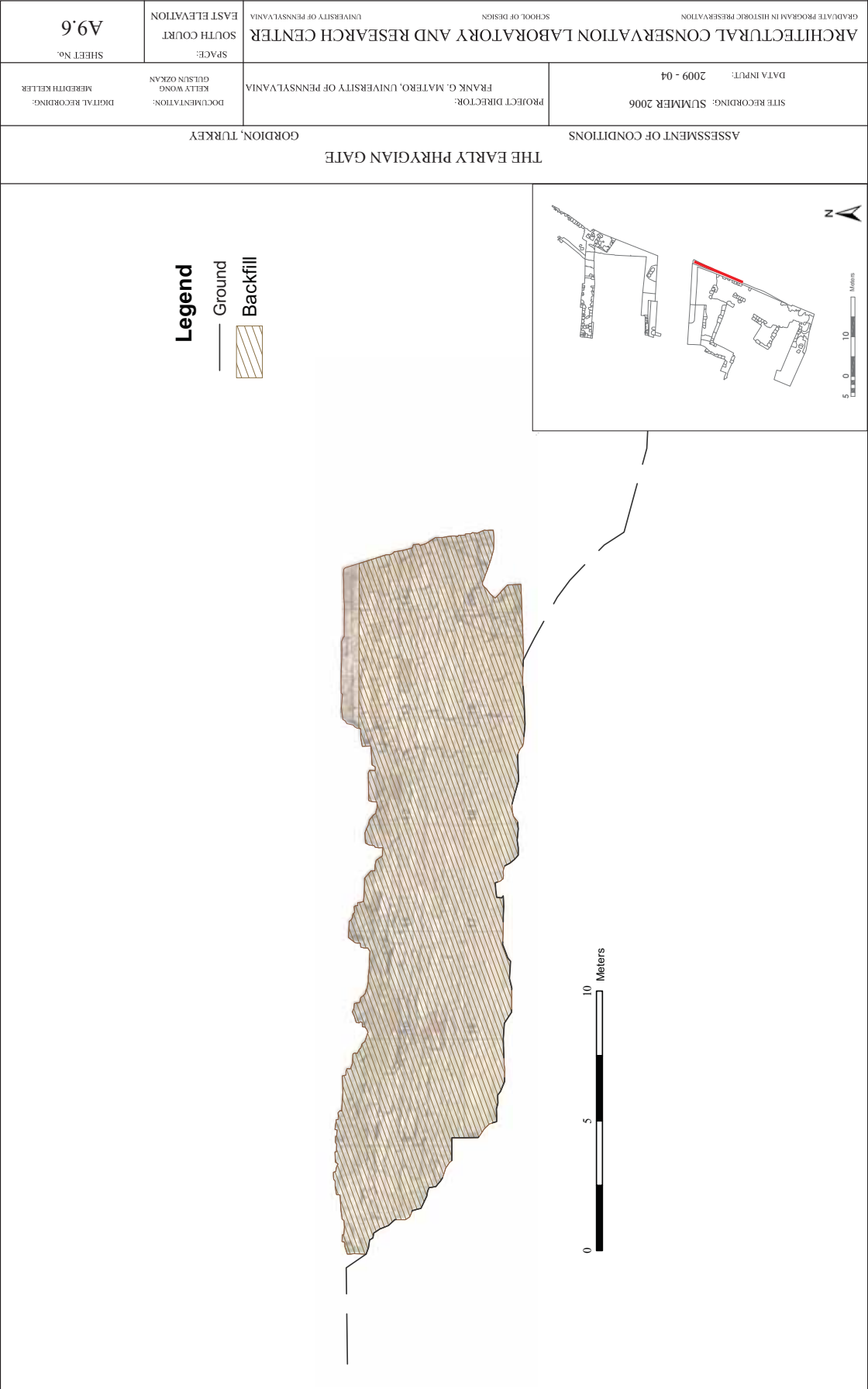

THE EARLY PHRYGIAN GATE
ASSESSMENT OF CONDITIONS
GORDION, TURKEY

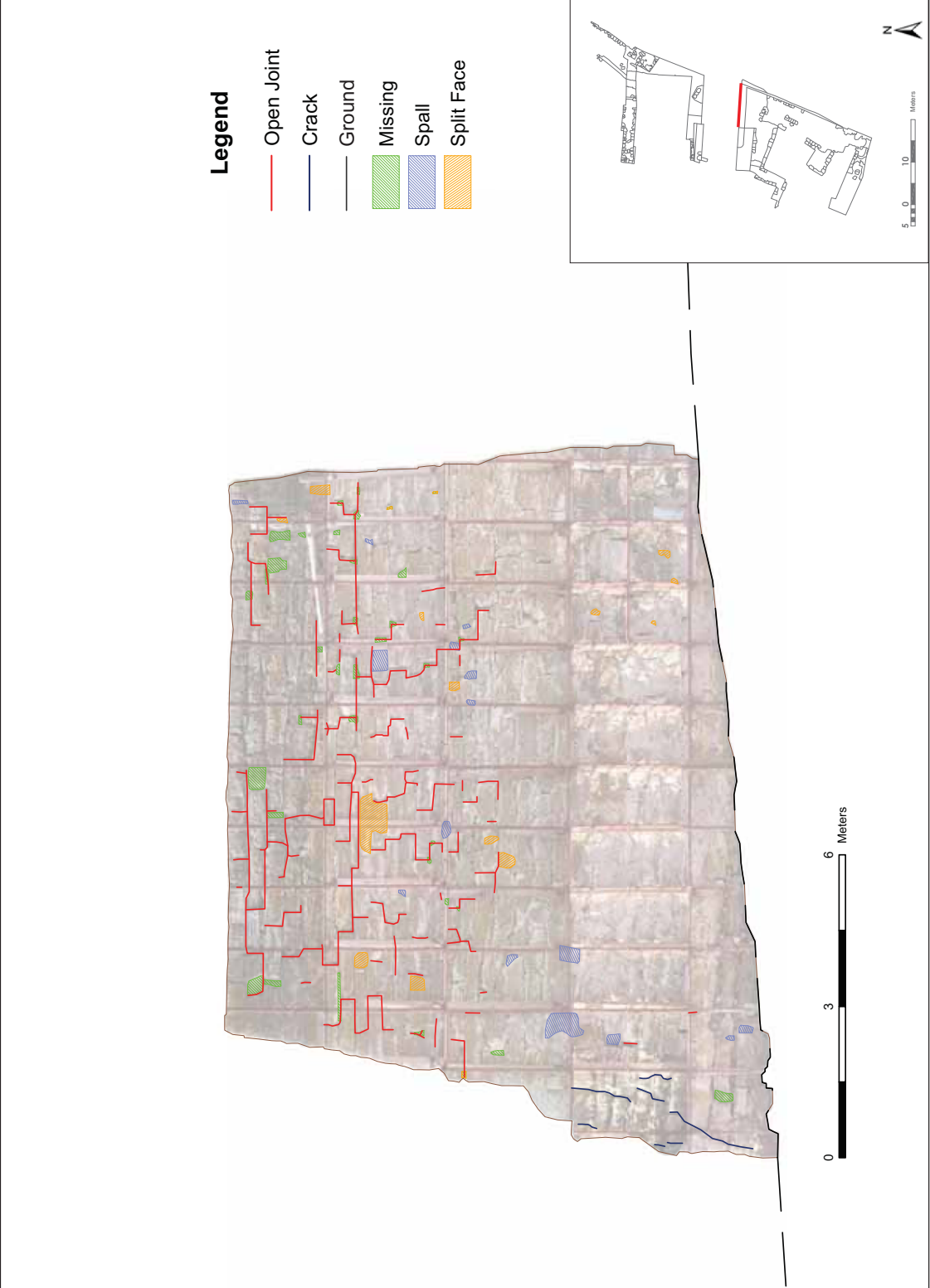

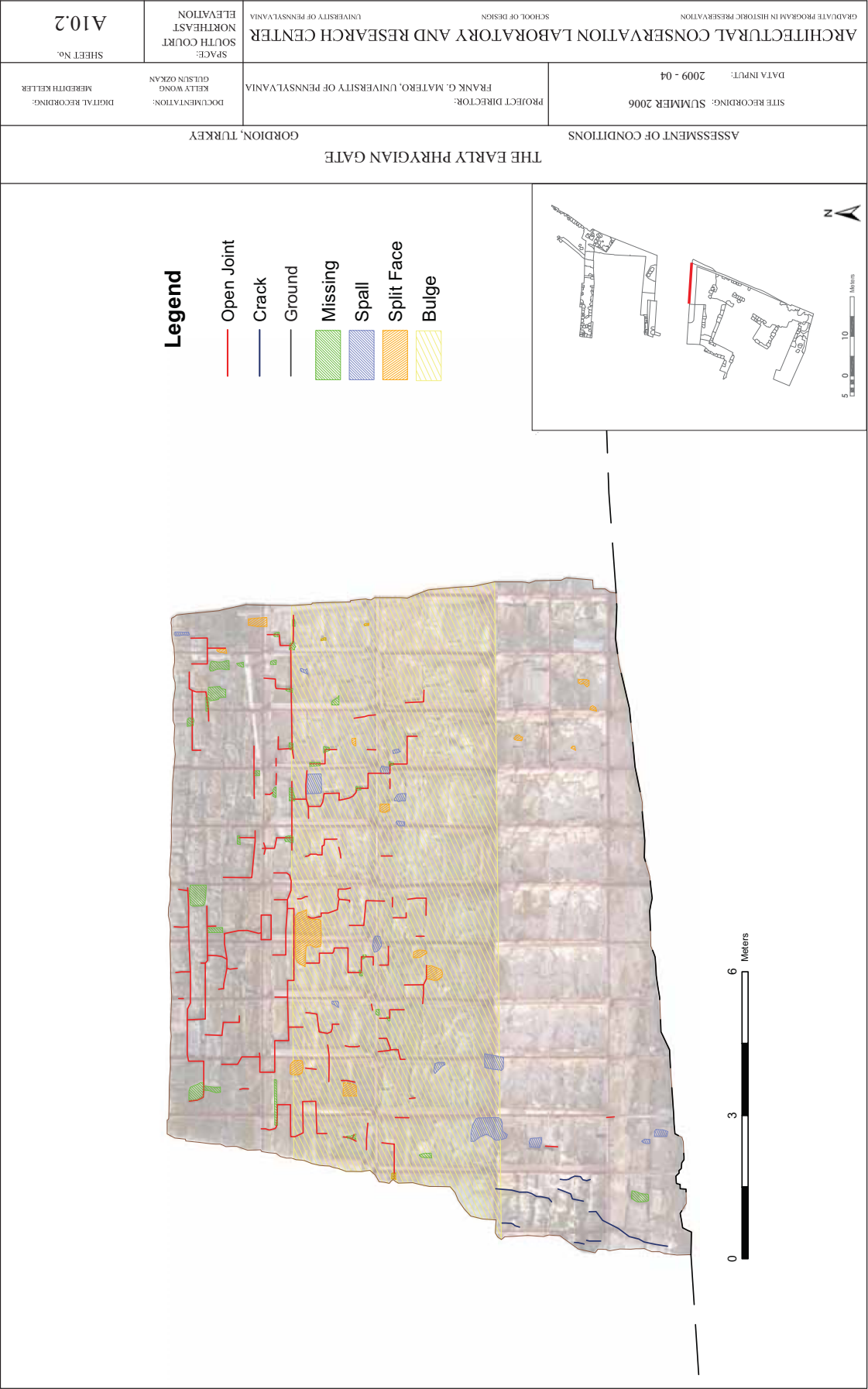

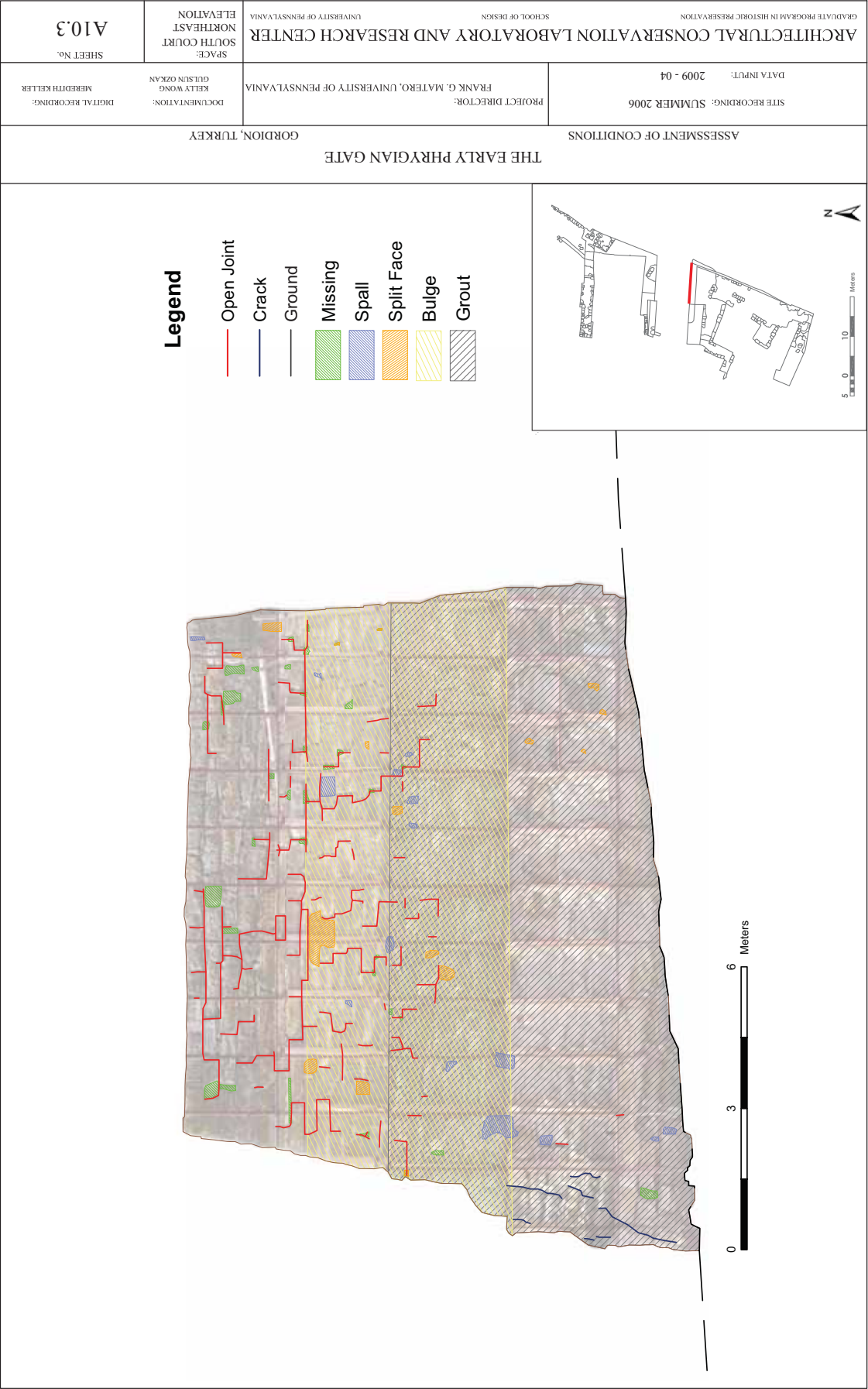

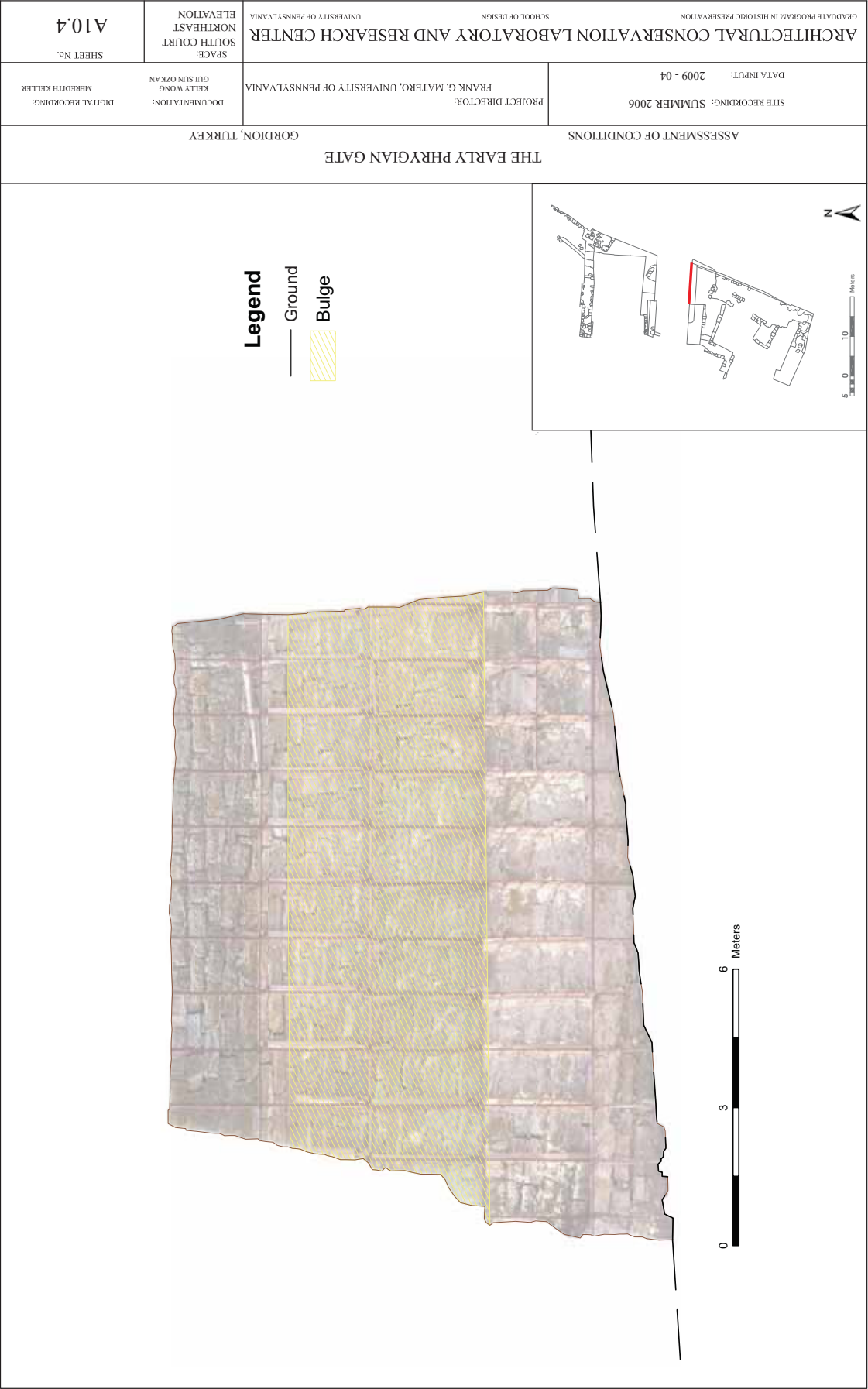

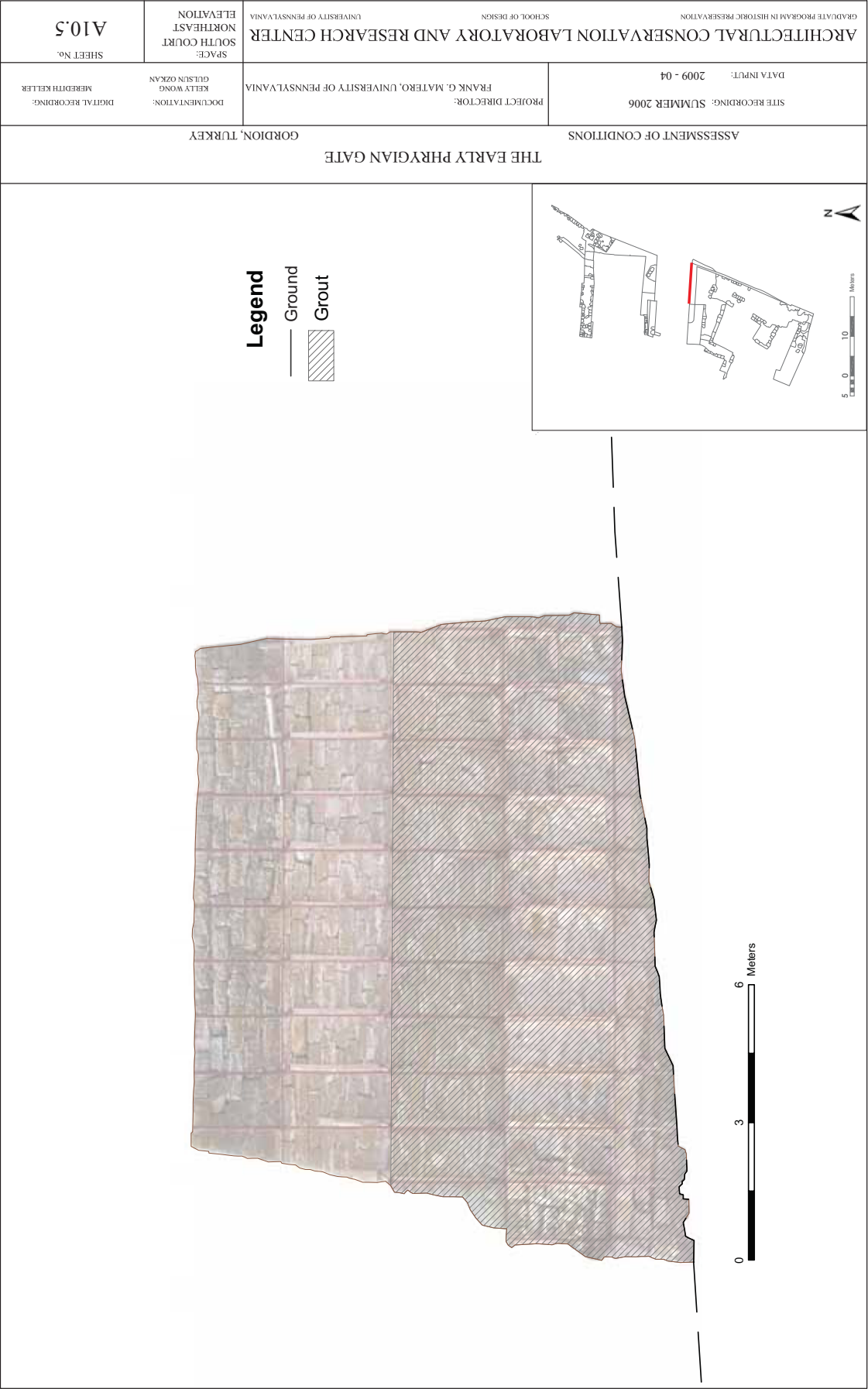

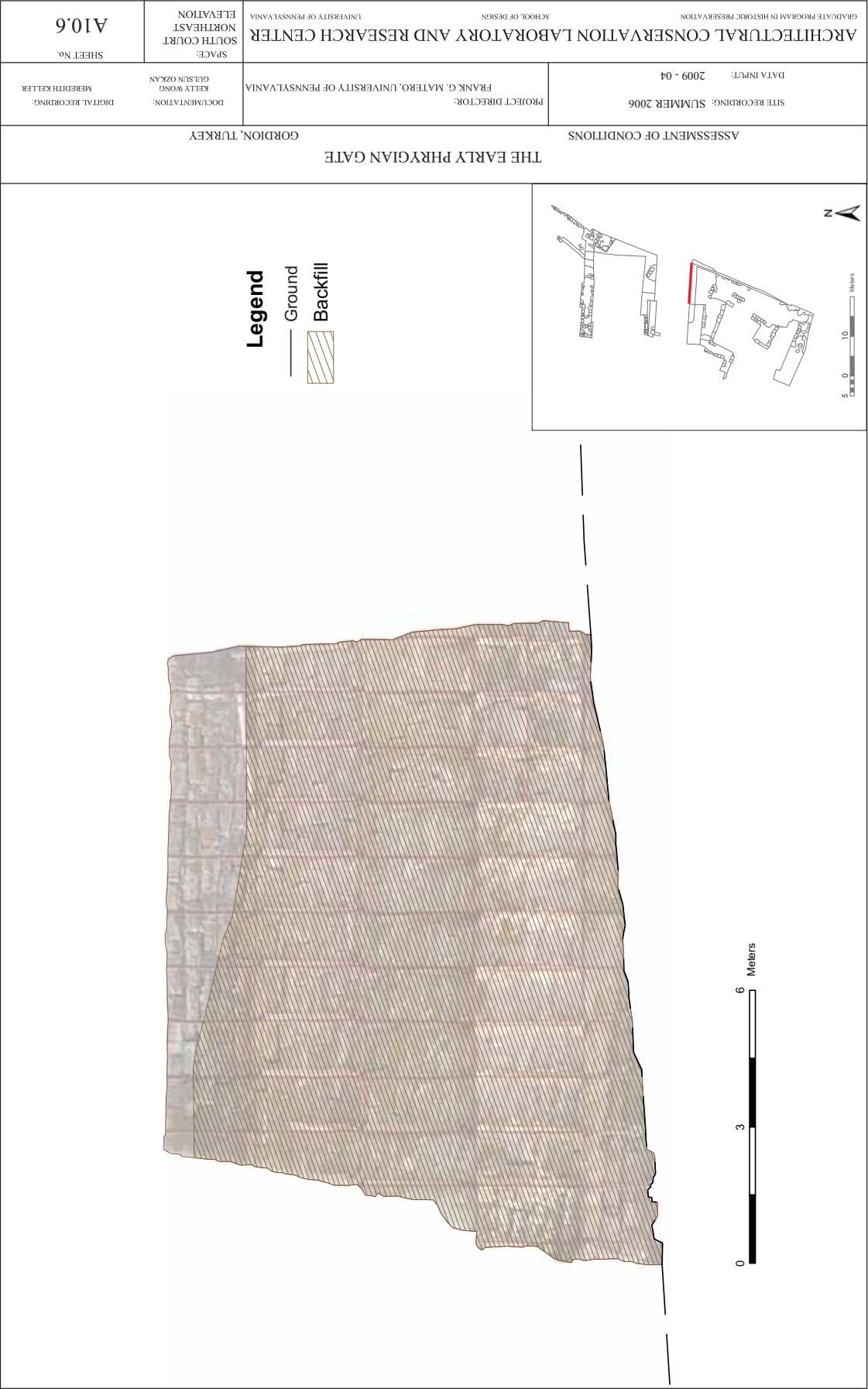

THE EARLY PHRYGIAN GATE
ASSESSMENT OF CONDITIONS
GORDION, TURKEY

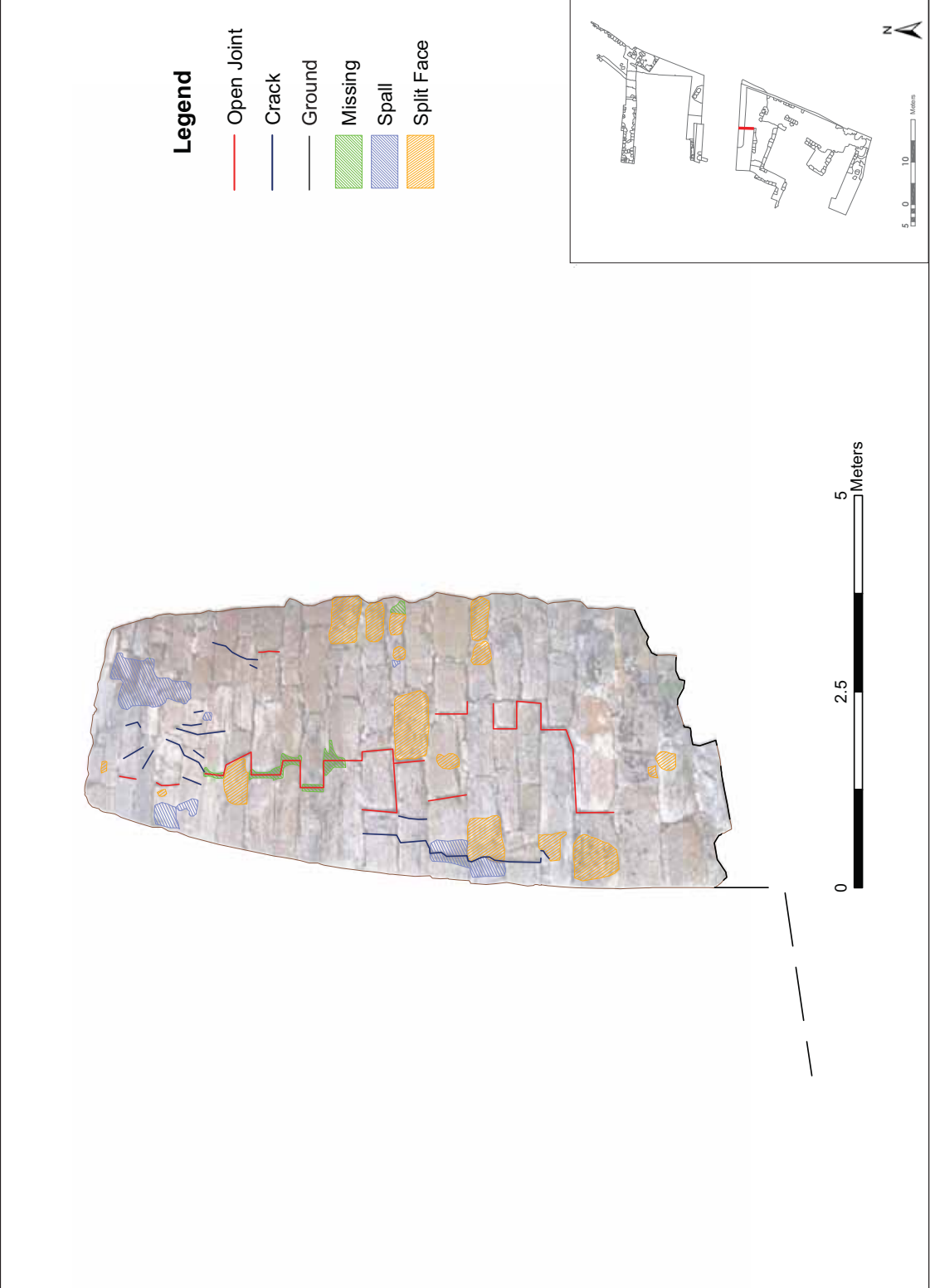

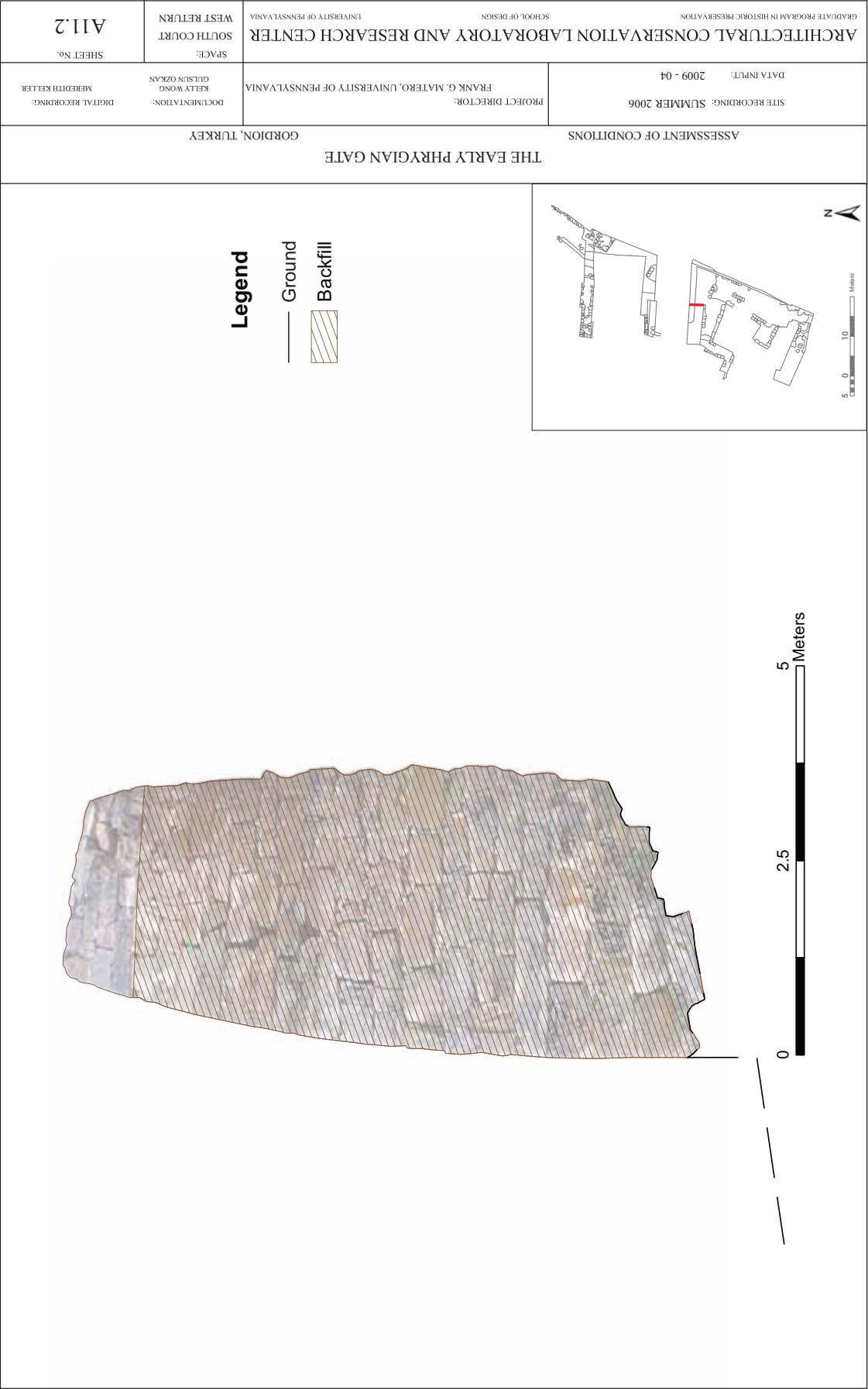

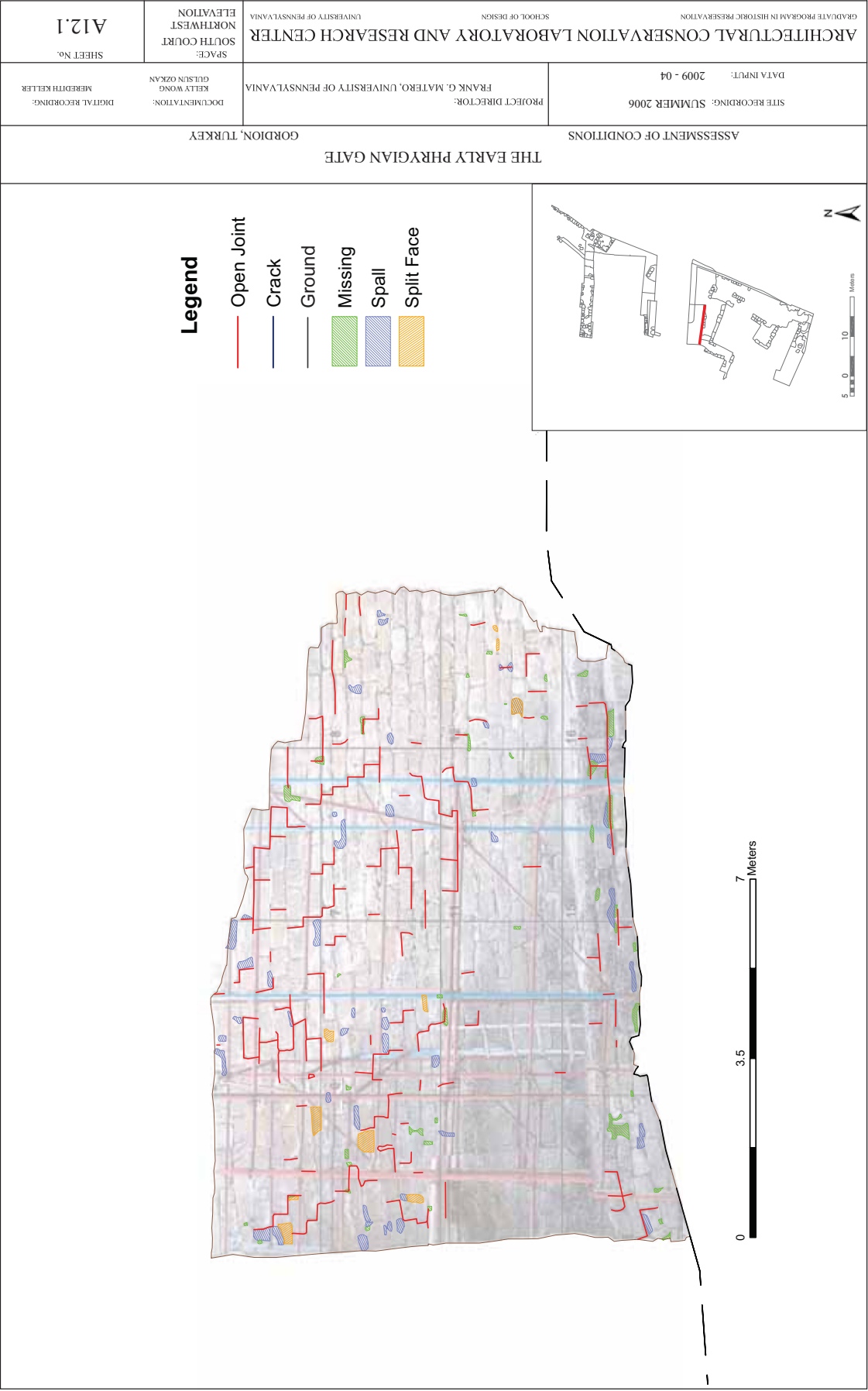

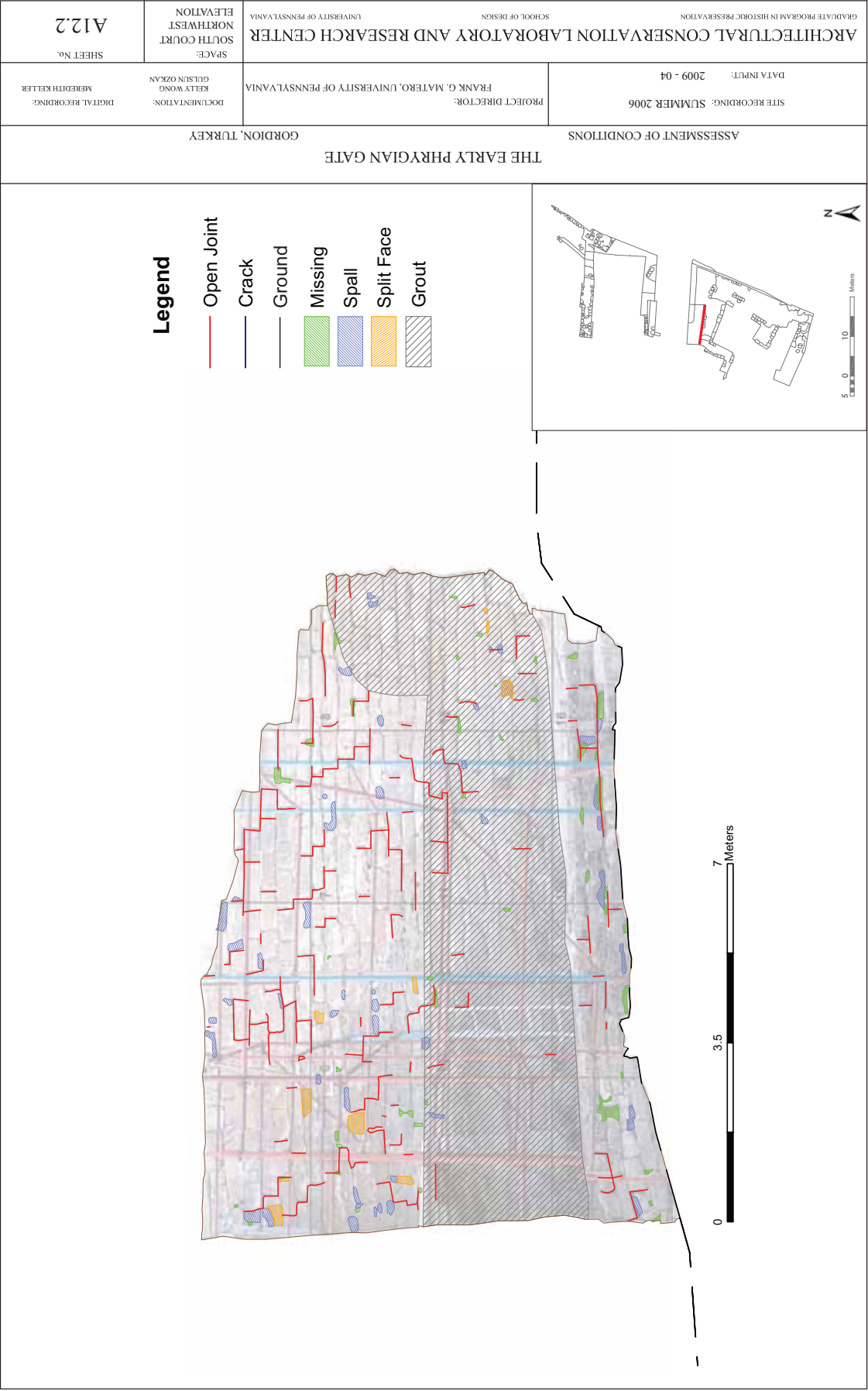





ASSESSMENT OF CONDITIONS

THE EARLY PHRYGIAN GATE

GORDION, TURKEY

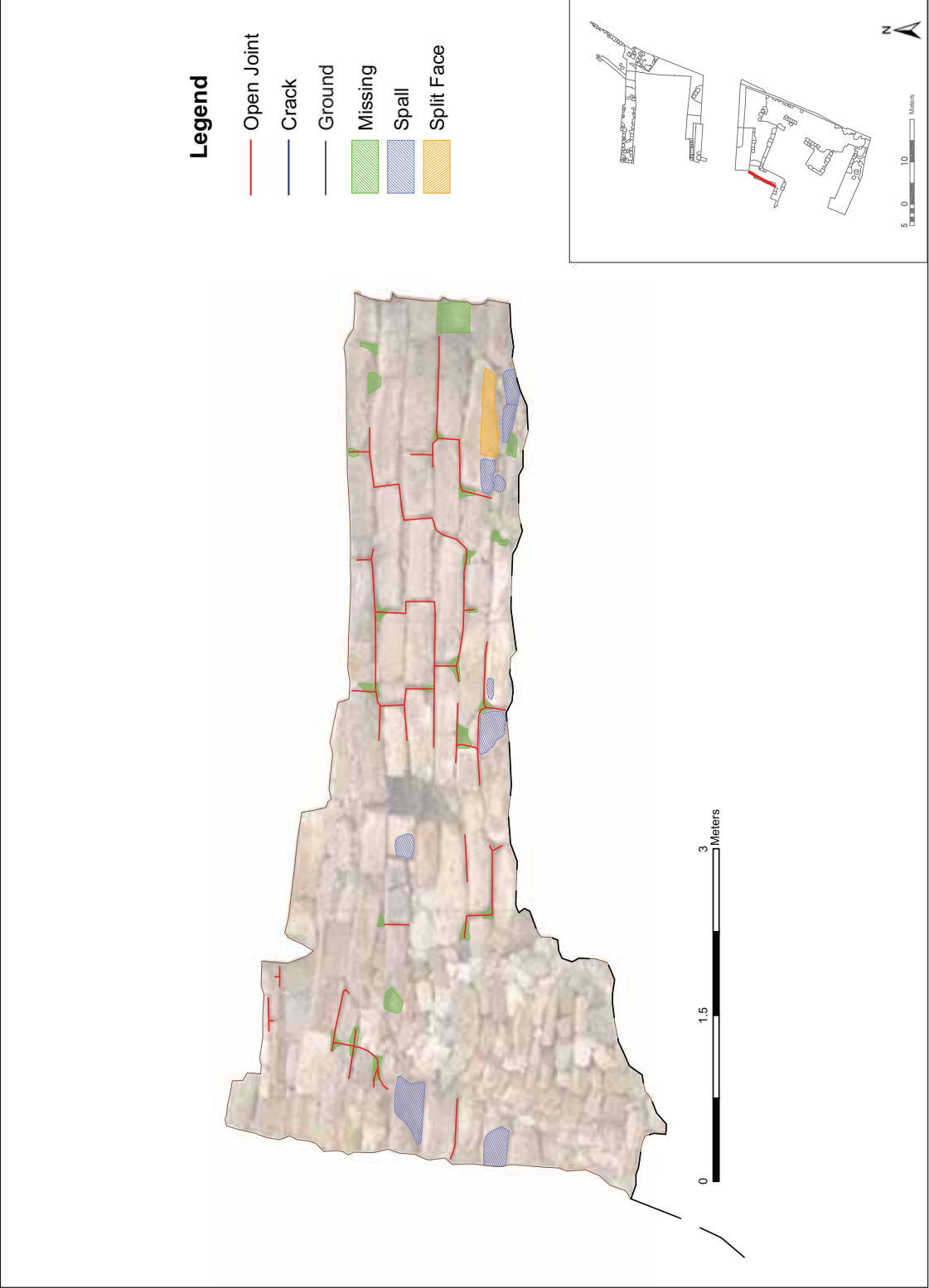



THE EARLY PHRYGIAN GATE
ASSESSMENT OF CONDITIONS
GORDION, TURKEY

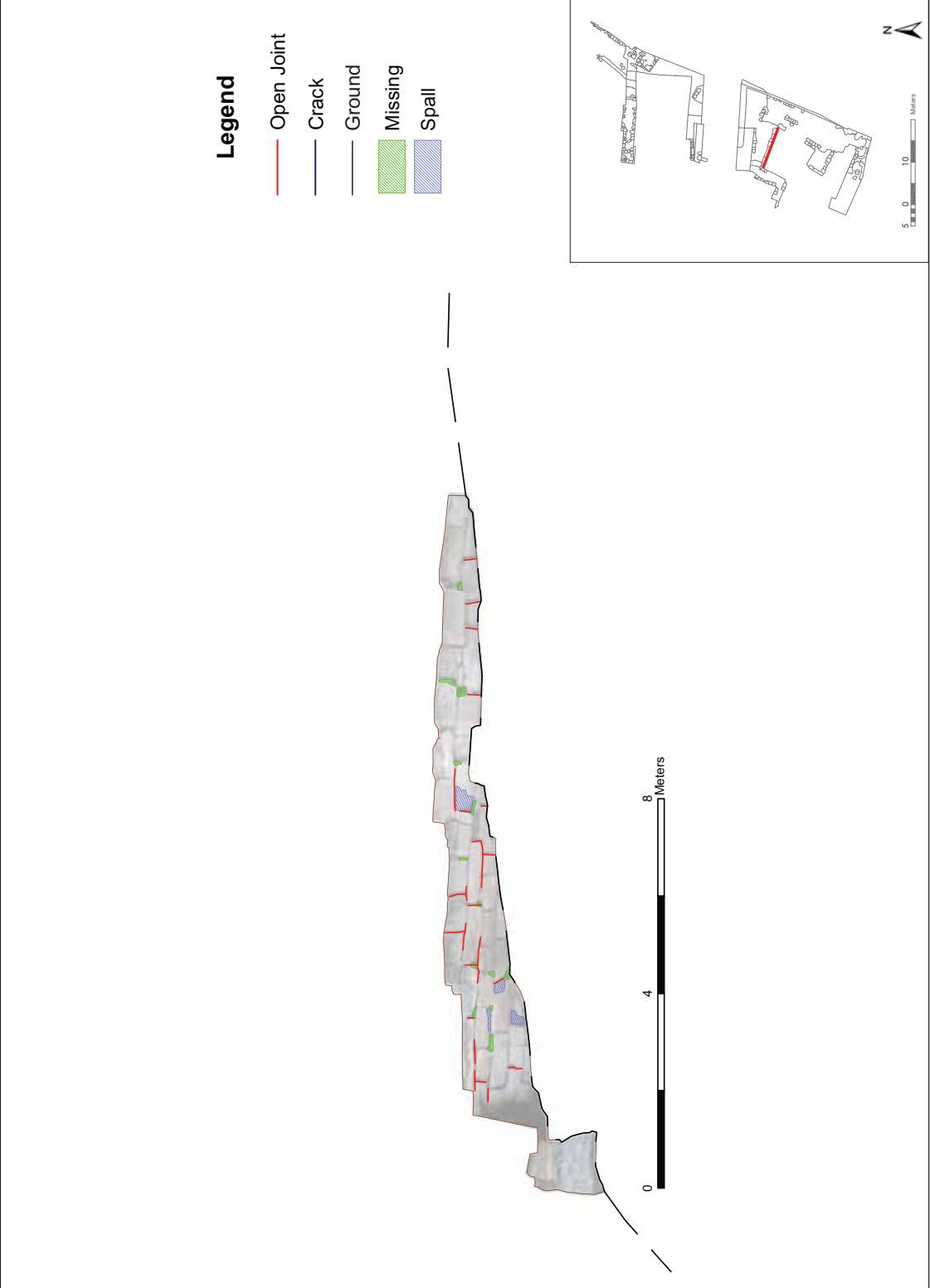

APPENDIX B

COMPARISON IMAGES

GATE ENTRYWAY - NORTH COURT



Gordion Archives, ca. 1955



Kelly Wong, 2006

GATE ENTRYWAY - SOUTH COURT



Gordion Archives, 1969.



Kelly Wong, 2006

ENTRYWAY FROM GATE COMPLEX INTERIOR



Gordion Archives, ca. 1955



Kelly Wong, 2006

GATE COMPLEX FROM THE WEST



Gordion Archives, 1953



Kelly Wong, 2006

INTERIOR OF GATE COMPLEX



Gordion Archives, 1955.



Kelly Wong, 2006.

GATE COMPLEX FROM NORTHWEST



Gordion Archives, 1956



Kelly Wong, 2006

NORTH COURT INTERIOR



Gordion Archives, ca. 1955



Kelly Wong, 2006

NORTH COURT EAST INTERIOR ELEVATION



Gordion Archives, ca. 1955



Kelly Wong, 2006

NORTH COURT INTERIOR



Gordion Archives, ca. 1955



Kelly Wong, 2006

NORTH COURT SOUTHWEST WALL



Kelly Wong, 2006



Gordion Archives, ca. 1955

SOUTH COURT NORTHWEST ELEVATION



Gordion Archives, ca. 1955



Kelly Wong, 2006

SOUTH COURT WEST RETURN



Gordion Archives, ca. 1955



Kelly Wong, 2006

INDEX

A

Aachen Cathedral v, 43, 62, 63
Alexander the Great 4, 7
alluvium 34
angle of repose 92
Ankara 3, 132
archaeology ii, 3, 50, 68, 76, 78, 79, 86, 118
architecture 1, 5
ashlar 10, 57, 78, 83
Atterberg limits 91, 113
AutoCAD 89

B

batter vii, 12, 20, 21, 70, 71, 78, 80
bed joints 45
bedrock 33, 50, 88
Belikopru Olnm 29
Binda, Luigia 42, 46, 49, 51, 61, 64, 85, 126, 131, 132
building v, 2, 6, 8, 9, 23, 34, 37, 42, 43, 44, 50, 51, 60, 62, 63, 74, 134
Building Research Establishment 72
bulge 25, 27, 36, 99, 100, 101, 102, 103, 107, 110, 115, 117
bulging 2, 30, 32, 35, 73, 77, 80, 81, 82, 84, 87, 90, 91, 92, 93, 94, 99, 100, 101, 106,
107, 108, 110, 116, 117
Burgoyne, Sir John 68, 69
burial 4, 6, 7, 16, 50, 51, 124
burial tumuli 16

buried 4, 8, 34, 95, 106, 114
buttressing 21, 25, 73, 74

C

cap vi, 22, 25, 26, 30, 86, 93, 94, 99, 100, 101, 109, 110, 111, 121
cement 26, 29, 46, 73
cement mortar 46
Central Anatolia v, 1, 32, 33, 35
central ramp 12
Cheax Blanche 29
chisel 11, 18
citadel 2, 3, 4, 5, 6, 7, 9, 11, 15, 17, 19, 22, 24, 32, 33, 34, 35, 36
citadel mound 2, 5, 6, 7, 11, 19, 22, 24, 34, 35
city wall 2, 9, 15
clay v, 5, 6, 8, 9, 11, 17, 19, 25, 35, 91, 92, 94, 96, 101, 103, 106, 107, 110, 112, 113, 114, 118
clay bank 19
clay cap 25
clay construction fill 6, 8, 9, 35, 91, 101, 106, 110, 112, 113, 114
clay fill 5, 113
climate 2–199, 32–199, 33–199
cobble stones 10
collapse 2, 5, 25, 32, 36, 37, 45, 46, 47, 49, 50, 58, 63, 74, 75, 82, 110, 119
composite materials 54
compression 8, 77, 93, 98, 99, 108, 109, 110, 114
compression cracking 99
compressive force 93, 97, 107
computer-generated models 37, 52, 53
concrete cap vi, 22, 25, 30, 86, 99, 100, 101, 109, 110, 121
concrete capping 2
condition 2, 20, 24, 30, 33, 50, 54, 72, 89, 92, 93, 97, 99, 100, 104, 110, 112
condition survey 30, 89, 93, 100
consolidate 28
construction techniques 2, 11, 38, 39, 41, 51, 67, 83, 88, 123
core 1, 10, 11, 22, 25, 26, 27, 28, 30, 45, 47, 60, 76, 78, 79, 80, 81, 83, 84, 86, 91, 92, 93, 98, 99, 100, 101, 102, 103, 108, 109, 110, 116, 117, 118, 119, 121, 122
cornices 50
Corps of Royal Engineers 68, 69, 126
Coulomb's friction 74, 75

court 9, 10, 13, 14, 15, 20, 89, 101, 107, 114
crack v, 25, 30, 42, 43, 47, 48, 60, 90, 97, 98, 104, 106, 117
crack monitors 30
crack patterns 42, 43, 47, 60, 90
cracks v, 8, 25, 45, 48, 49, 51, 55, 59, 64, 67, 93, 96, 97, 98, 99, 102, 104, 106, 107, 109,
114, 117, 118
Cundall, Peter 39
current conditions 2, 32, 42, 91, 93, 115, 120, 123
cyclic loading 75
cyclic loads 45

D

dam 19
decay mechanism 25
defensive walls 10, 12
deflect 81
deformation 44, 45, 46, 47, 48, 49, 75, 77, 79, 83
DEM/FEM 38, 40, 56, 57
densification 43
Destruction Level 5, 24, 134
deterioration 13, 17, 22, 24, 26, 29, 39, 59, 80, 81, 82, 90, 92, 93, 94, 107, 108, 110, 114
diagonal cracks 49
discrete element method 39, 41, 52
displacement 2, 13, 18, 19, 25, 26, 27, 41, 46, 48, 55, 81, 83, 89, 90, 91, 92, 93, 94, 95,
97, 98, 100, 102, 104, 106, 108, 109, 110, 112, 116, 117, 118, 119, 121, 124
drain 24, 111
drainage 9, 26, 80, 87, 101, 107, 109, 121
drainage system 9, 26
dressed tooling 11
dry laid 10, 11, 73, 86, 88, 106
dry stone v, vii, 1, 2, 2–199, 19, 41, 45, 46, 47, 48, 54, 55, 57, 64, 68, 69, 71, 72, 73, 74,
75, 76, 77, 78, 79, 80, 81, 82, 83, 85, 88, 119, 123, 124
dry stone retaining wall 68

E

Early Bronze Age 4

early gate house 8
Early Phrygian iii, v, 1, 2, 4, 5, 6, 7, 8, 9, 11, 15, 17, 18, 19, 20, 22, 23, 30, 31, 33, 34, 80,
83, 93, 108, 112, 115, 116, 132, 134
earthen plaster finish 13
earthquake damage 38, 47
earthquakes 35, 36, 51, 52
Eastern Mediterranean 3
energy dissipation 41, 46
entryway v, 2, 8, 9, 10, 11, 12, 18, 23, 95, 98
environment 1, 25, 36, 69, 77, 85, 109, 114, 122
erosion 24, 94, 116
Eurocode 8 51
excavation 11, 13, 16, 17, 20, 21, 22, 23, 24, 25, 31, 32, 90, 95, 96, 97, 98, 101, 102, 106,
107, 108, 110, 115, 118, 134
existing conditions v–199, 2–199, 36–199, 37–199, 42–199, 47–199, 50–199, 51–199,
53–199, 59–199, 60–199, 61–199, 120–199

F

failure mechanisms 31, 36, 37, 40, 45, 51, 52, 57, 60, 62, 66, 69, 72, 74, 75, 123, 124
Farneta Abbey v, 65, 66
fault lines v, 35
Fielden, Bernard 27
finite element methods 38
fire 5, 6, 8, 9, 15, 17, 24, 32, 124
floodplain 33, 34
fluidification 43
fly ash 29
fortification wall 17
foundation v, 6, 8, 11, 12, 17, 18, 19, 35, 87, 88, 92, 96, 98, 100, 104, 117
France 29
freeze/thaw 33, 92, 114, 115
freeze/thaw heave 92
friction 41, 45, 47, 54, 59, 74, 75, 76, 77, 78, 79, 80, 82, 83, 86, 87, 113, 116, 118
friction angle 47, 82, 83
friction failure 54

G

- gate v, 1, 2, 7, 8, 9, 11, 13, 15, 16, 17, 19, 20, 21, 22, 23, 24, 25, 26, 28, 30, 31, 32, 33, 34, 36, 86, 89, 90, 92, 93, 95, 96, 98, 101, 105, 108, 110, 111, 112, 113, 114, 116, 118, 119, 120, 121
- gate complex v, 1, 7, 8, 9, 17, 19, 22, 23, 24, 25, 28, 30, 93, 105, 112, 113, 118, 119, 121
- Germany v, 42, 62, 63
- glass 5, 25, 87
- glass tell-tales 25
- Goodman, Mark 12, 27, 36, 103
- Gordion 1, 3, 4, 5, 6, 7, 8, 9, 10, 11, 12, 13, 14, 15, 16, 17, 18, 19, 21, 22, 23, 24, 25, 26, 27, 30, 32, 33, 34, 36, 76, 78, 80, 83, 86, 94, 95, 96, 97, 98, 99, 100, 102, 103, 104, 105, 114, 120, 127, 128, 129, 130, 132, 133, 134, 172, 173, 174, 175, 176, 177, 178, 179, 180, 181, 182, 183
- granular assemblies 39
- gravity grouting 27, 28, 106
- Great Zimbabwe National Monument iv, v, 86, 87
- Greek temples 40
- ground movement 2, 32, 36, 45, 46, 53, 92, 101, 110, 112, 120, 121
- grouting v, 2, 27, 28, 29, 30, 31, 64, 83, 84, 85, 86, 88, 89, 94, 101, 106, 107, 108, 109, 110, 115, 117, 120, 121
- grout injections 64, 74

H

- hand recording 89
- harmonic shaking 57
- head joints 11, 14
- Hellenistic 7
- high-frequency/low energy waves 43
- high-frequency waves 43
- historic photographs 90, 98
- Hittite empire 5
- horizontal loads 44, 48, 64, 66
- hydraulic set 28, 29
- hydrostatic pressure 35, 64, 94, 107, 109

I

inelastic sliding 45, 48
In-field assessments 37
injection grouting 2, 28, 31, 83, 84, 85, 89, 94, 101, 106, 108, 109, 115, 120
in-plane movement 36, 93
interior Anatolian plateau 32
intervention 27, 63, 66, 67, 72, 73, 74, 84, 88, 92, 94, 119, 120, 121, 124
Iron Age v, 1, 4, 5, 7, 36
Izmit earthquake v, 27, 28, 103, 110

J

jacketing 64, 65
joint contact interfaces 45
joint interface 59, 79, 82, 83
joints 2, 8, 11, 14, 18, 27, 45, 47, 48, 54, 58, 59, 83, 87, 93, 94, 96, 98, 101, 106, 107, 109, 117, 118

K

King Midas 4, 6, 7
Körte, Alfred 7, 16

L

Lafarge Co 29
large-scale cracking 50, 89, 93
laser theodolite 25, 118
lateral force 35, 82, 95, 100, 101, 107, 108, 109, 114, 117, 118, 119, 121
lateral load 31, 100
lateral pressure 19, 31, 33, 35, 47, 91, 93, 99, 101, 105, 107, 110, 118
lateral thrust 47, 106
ledge 12, 96, 97, 98, 104
lime mortars 28
limestone 1, 10, 11, 12, 15, 18, 26, 29, 83, 92, 113, 114, 115
limit equilibrium analysis 75
linear analysis 54

linear deformation 48
lintels 49
load 2, 8, 16, 26, 31, 34, 35, 36, 37, 49, 51, 54, 57, 58, 60, 62, 66, 67, 69, 73, 77, 84, 90,
92, 93, 96, 97, 98, 100, 103, 107, 110, 112, 114, 115
Lydians 7, 17

M

macro model 55
marl 34
masonry 2, 11, 12, 25, 28, 29, 36, 37, 38, 39, 41, 42, 43, 44, 46, 47, 48, 49, 52, 53, 59,
60, 68, 69, 72, 77, 78, 81, 88, 93, 97, 98, 107, 130, 135
masonry bonded 12
masonry walls 11, 42, 43, 46, 72
material loss 73, 112, 113, 114, 115, 116, 121
Matero, Frank ii, 21, 30
mechanical tests 114
Mediterranean coast 32
megaron 6
megaron district 6
mesoscopic 55
METU 30, 89
micro grout injections 30
micro-scale 55, 56
Midas 4, 5, 6, 7, 12, 16, 34, 128, 129, 130
Middle Ages 4
Middle East 1, 7
Middle Phrygian v, 6, 8, 15, 16, 17, 18, 19, 20, 21, 22, 24, 31, 35, 90, 92, 93, 94, 95, 96,
97, 98, 99, 100, 101, 103, 107, 108, 110, 114, 115, 134
MIT 43, 130, 135
monitor 24
monitoring 1, 2, 25, 27, 31, 43, 52, 68, 87, 89, 90, 91, 94, 100, 101, 110, 112, 115, 116,
117, 118, 119, 124
mortar 28, 30, 41, 46, 55, 56, 79
mortared construction 41
mound 2, 4, 5, 6, 7, 11, 16, 19, 22, 24, 34, 35
movement 1, 2, 25, 27, 32, 35, 36, 45, 46, 52, 53, 54, 55, 57, 58, 62, 68, 76, 79, 80, 81,
83, 87, 91, 92, 93, 94, 96, 98, 100, 101, 103, 104, 106, 107, 110, 112, 116, 117,
118, 119, 120, 121

multiple leaf v, vii, 1, 11, 43, 46, 47, 49, 61, 64, 65, 84, 106, 110, 116, 119, 121, 123
multiple leaf system v, 11, 49, 116
multi-scale 40, 55

N

nondestructive testing 42, 67
North Anatolian Fault 35
North Court iv, v, 12, 14, 15, 21, 22, 30, 31, 90, 91, 94, 95, 97, 98, 99, 100, 101, 104,
110, 117
northern wall 11, 25
numerical modeling 38, 57

O

Old Citadel 4
open joint 105
Ottoman 7
outer veneer 10, 27, 91, 92, 101
out-of-plane bending v, 36, 44, 49, 63, 65, 66
out-of-plane displacement 91, 118
out-of-plane movement 25, 45, 91, 93, 118, 119
overturning 47, 69, 80, 81, 84

P

Palace Area 6
paleosol 34
parapets 50
Parthenon 40, 41, 57, 58, 59, 131, 132
paving stones 15
Phrygian iii, v, 1, 2, 4, 5, 6, 7, 8, 9, 11, 15, 16, 17, 18, 19, 20, 21, 22, 23, 24, 25, 30, 31,
33, 34, 35, 80, 83, 90, 92, 93, 94, 95, 96, 97, 98, 99, 100, 101, 103, 107, 108, 110,
112, 114, 115, 116, 132, 133, 134
pinning 27, 73, 83, 84, 88
plaster v, 13, 14

plumblines 27, 103, 118
Polychrome House v, 9, 10, 22, 23
Portland cement 73
potential energy 45
pottery 5
precipitation 33, 92, 94, 119
preexisting conditions 50

R

ramp 10, 11, 12
recommendation 27
red fan clay 35, 94, 101
reinforced concrete 64
reinforcing nets 65
retaining walls 31, 68, 69, 72, 74, 77, 78, 82, 83, 86, 92
retrofitting 39, 64, 67
rhyolite 1, 10, 11, 92, 113, 114, 115
river 34
rocking 45, 57, 58
Roman 7
roof failure 50
roofing structure 14
roofing systems 50
rotation 58, 80, 93, 99, 100, 101, 104, 106, 110, 117, 118
royal tomb 6
rubble 1, 8, 10, 11, 17, 18, 19, 20, 21, 22, 25, 26, 27, 30, 41, 43, 45, 46, 47, 64, 65, 78,
79, 81, 83, 86, 91, 92, 93, 98, 101, 102, 103, 108, 110, 117, 118, 121
rubble core 1, 10, 11, 22, 25, 26, 27, 30, 45, 79, 81, 83, 86, 91, 92, 93, 98, 101, 102, 103,
108, 110, 117, 118, 121
rubble fill 17, 19, 20, 43, 47

S

Sakarya River 3, 33, 34
Sangarios River 33
scaffolding v, 28, 91, 108

sediment 34
 sedimentation 34
 seismic v, 2, 27, 33, 35, 36, 37, 38, 39, 40, 41, 42, 43, 44, 45, 46, 47, 48, 50, 51, 52, 53,
 55, 57, 58, 59, 60, 62, 63, 64, 66, 67, 76, 80, 84, 103, 108, 112, 116, 117, 119, 121,
 123
 seismic behavior 36, 37, 38, 39, 40, 43, 47, 50, 52, 60, 119, 121, 123
 seismic conditions 2–199, 38–199, 43–199, 52–199, 123–199
 seismic damage 38
 seismicity 32
 seismic loads 37, 44
 seismic modeling 112
 seismic strengthening 40, 43
 semi-dry 33
 settlement 1, 7, 16, 30, 34, 50, 71, 77, 80, 84, 91, 92, 93, 99, 100, 101, 102, 103, 108,
 110, 116, 117, 119
 settlement 92, 101
 shaking tables 38, 41
 shear failure v, 45, 49, 54, 74
 shrinkage 28
 silts 34
 simulations 37, 40, 42, 43, 52, 55, 59, 61, 67, 76
 sliding 18, 19, 45, 48, 57, 58, 59, 77, 81, 82, 87, 93, 104, 105, 106, 107, 108
 soil backfill 31, 33, 70, 81, 83, 94, 99, 100, 119, 120
 soil monitoring 118
 soil mortars 113
 soil nailing vii, 84
 soil nails 73, 84, 85
 soil pressure 87, 108
 soil properties 2, 91, 124
 soil-structure interaction 32, 33, 34, 90, 91, 112, 115, 118
 soil volume expansion 113
 South Court iv, v, vi, 9, 12, 13, 14, 15, 17, 25, 26, 27, 28, 29, 30, 31, 34, 35, 36, 89, 90,
 91, 92, 94, 95, 101, 102, 103, 104, 105, 108, 110, 114, 115, 116, 117, 118, 120
 southeast elevation v, 14, 91, 95, 96
 southeastern Europe 4
 southeast exterior elevation 14
 southern elevation 98
 southern wall 11, 22, 95
 spalls 2, 93, 101, 114
 splinters 18

split faces 2, 8, 93, 97, 101, 106, 107, 114
stability 2, 11, 16, 18, 20, 25, 30, 31, 32, 33, 45, 46, 47, 71, 73, 74, 75, 76, 78, 79, 80, 81, 83, 84, 86, 87, 88, 92, 93, 98, 100, 101, 110, 113, 114, 115, 116, 119, 121, 123
stabilization 2, 25, 26, 74, 120
static friction 41, 116
steel meshes 64
steel tie beams 67
stepped cracks 48, 49, 96, 98, 102, 107
stepped flexural cracks 45
stick-slip 45
stone v, vii, 1, 2, 8, 9, 11, 17, 18, 19, 21, 23, 31, 38, 39, 41, 43, 44, 45, 46, 47, 48, 54, 55, 57, 64, 67, 68, 69, 71, 72, 73, 74, 75, 76, 77, 78, 79, 80, 81, 82, 83, 84, 85, 86, 87, 88, 89, 92, 93, 97, 112, 113, 114, 115, 116, 119, 123, 124
stone rubble 18, 47
structural conditions 2, 107
structural monitoring 112
structural support 19, 21
sun-dried brick 14

T

temperatures 33
tensile failure 54
textile 6
textile production 6
three leaf 10
three-point bending 113, 114
through stones 46, 79, 84, 86, 87
tooling 11, 15, 18
toppling 72, 73, 81, 82, 87, 94, 96, 106, 110
tumuli 5, 6, 16
Turkey 1, 3, 21, 27, 30, 32, 33, 35, 36, 38, 39, 46, 80, 126, 128, 129, 131, 132, 133, 134
tying mechanism 11, 46, 79, 84, 86, 121

U

United Kingdom 72, 86
University of Aachen 42
University of Pennsylvania 1, 6, 7, 12, 14, 16, 21, 24, 30, 34, 42, 89, 94, 128, 129, 130,
134
unreinforced columns 40
UPenn 30, 80, 132

V

vegetation growth 81
vener 1, 10, 11, 18, 26, 27, 30, 45, 47, 78, 81, 83, 84, 89, 91, 92, 93, 97, 98, 100, 101,
102, 103, 104, 105, 106, 110, 116, 117, 118, 120, 122
vertical face vii, 70, 71
vertical fractures 48
Voigt, Mary 24

W

water absorption/desorption 113, 115
water ingress 2, 17, 22, 25, 81, 86, 87, 92, 93, 107, 109, 110, 121
water runoff 104
weathering 2, 14, 39, 40, 41, 59, 60, 72, 73, 75, 76, 77, 80, 81, 82, 86, 87, 93, 100, 109,
110, 112, 113, 114, 115, 119, 120, 121, 124
weep holes 94, 106
white lime powder 13
whitewash 13
Wong, Kelly 14, 30, 94, 133, 172, 173, 174, 175, 176, 177, 178, 179, 180, 181, 182, 183
wooden foundation 96, 98
wooden tie 11, 92, 121

Y

Young, Rodney iii, 7, 16, 17, 23, 24