Copyright © 1980 Ohio Acad. Sci.

0030-0950/80/0003-0125 \$1.50/0

BRIEF NOTE

AN OPTICAL CANOPY COVER INSTRUMENT¹

ALLAN M. HALE, Dames & Moore, 1150 West 8th Street, Cincinnati, OH 45203

OHIO J. SCI. 80(3): 125, 1980

The estimation of canopy cover in the field has been a laborious, cumbersome, or otherwise inaccurate procedure. The need for an accurate means of canopy cover determination has been acknowledged as canopy cover gives a better measurement of plant biomass than that given by counting the number of individual plants (Mueller-Dombois and Ellenberg 1974). A wide range of canopy cover estimation techniques or procedures have been developed, including canopy cover estimation through vertical photography (Evans and Coombe 1959). Another method of canopy cover estimation uses the indirect method of measurement with light meters of the amount of light penetrating the canopy (Buell and Cantlon 1950, Eber 1972). The disadvantages of the light measurement method are that it is time-consuming, and the results

cannot be expressed directly as percent canopy cover. Various viewing devices have been developed to measure the canopy cover with mixed success (Buell 1936, Garrison 1949, Holdsworth *et al* 1936, Morrison and Yarranton 1970, Robinson 1947, and Shepperd 1973). Generally, the ocular estimate methods are most accurate in stands of low density but become progressively more difficult as the canopy cover increases (Avery 1975). As a result, the major limitations of the viewing devices include problems associated with measurement precision and accuracy, and most of these methods involve significant time or cost expenditures which greatly influence the scope of field survey studies.

The primary objectives of my study were to develop, construct, and evaluate under field conditions, a canopy cover instrument which would overcome some of the precision, accuracy, cost and size

¹Manuscript received 26 March 1979 and in revised form 10 September 1979 (#79-17).

limitations of previous methods of canopy cover determination.

Field durability required the development of an optical canopy cover instrument with significant differences from previously developed designs. Several versions of hand portable optical canopy

cover instruments were designed, fabricated and refined until a satisfactory instrument design emerged. The specific design and dimensions for this optical canopy cover instrument are provided in figure 1. The instrument uses several commonly available, inexpensive parts.

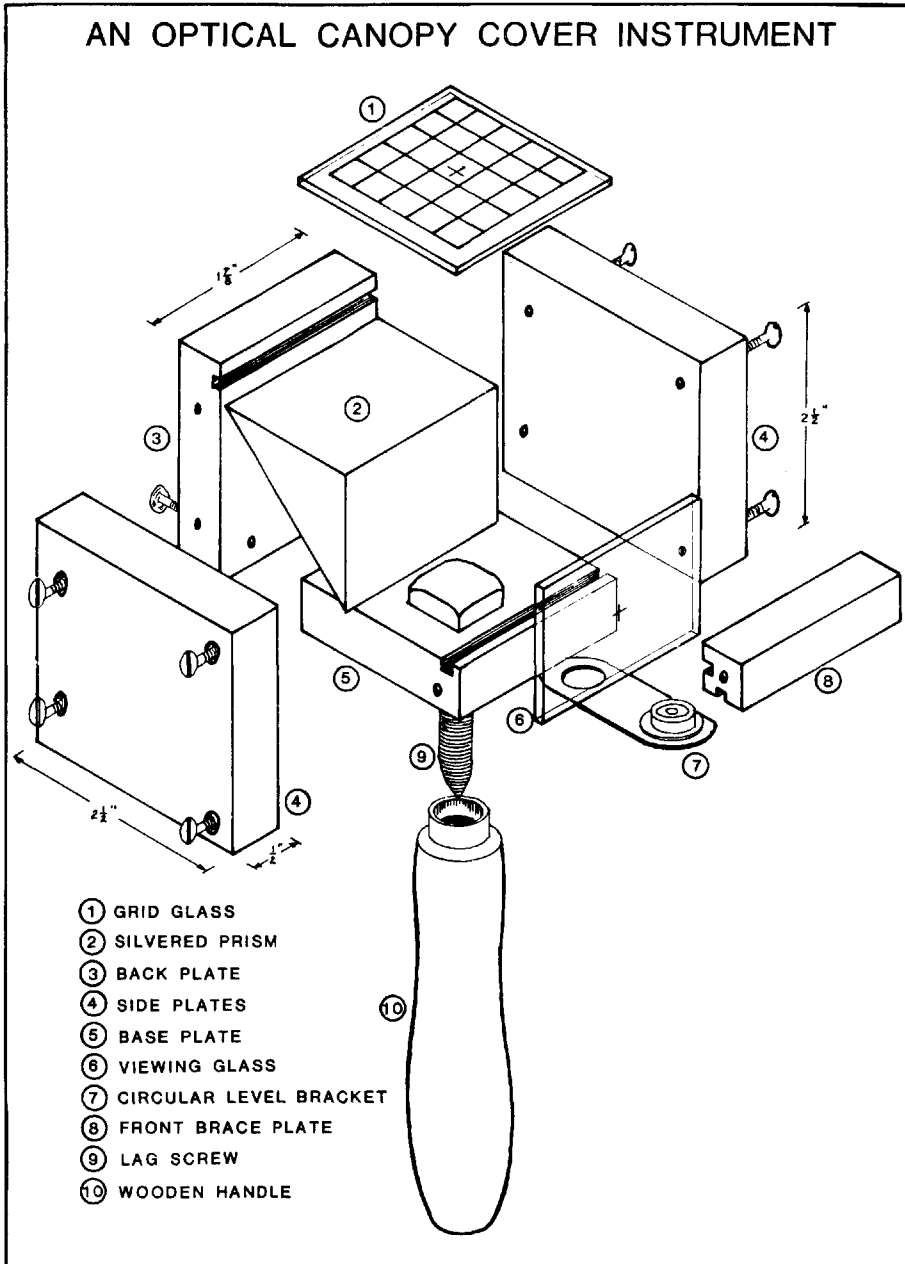

The right-angle silvered prism, the heart of the instrument, can readily be obtained from optical supply firms. Construction should begin only after the prism has been obtained to assure that the dimensions of the instrument are compatible with the size of the prism.

The instrument housing is made of hardwood to ensure durability for field use. After the instrument dimensions have been determined, the back plate, side plates, base plate, and front brace plate can be cut. The screw holes should be carefully aligned, pre-drilled and countersunk to provide a tight fit and to prevent the hardwood from splitting or cracking. The back plate, base plate and front brace plate require a shallow channel to allow the grid glass and viewing glass to slide securely in place as the instrument is assembled. This channel can be made using a router or a saw having a kerf width approximately the thickness of the glass selected for the grid and viewing glass.

The base plate should be drilled to allow for the passage of a lag screw to be inserted through the hole and glued in place, thus allowing for removal of the wooden handle, whenever required, without the need to disassemble the unit. The lag screw can be connected directly to a wooden handle (as shown in figure 1), or it can accommodate a Jacob's staff, if desired.

After the base plate has been secured to the back plate and one of the side plates, the front brace plate can be aligned and fastened into position. This partial assembly will allow the size measurement to be made for both the grid glass and viewing glass. At this time, the right-angle silvered prism should be thoroughly cleaned and carefully positioned to ensure that each side of the right-angle is parallel to the grid or viewing glass. The prism can then be secured by using silicone seal compound to hold the prism in place and to absorb any vibrations during field use.

The grid and viewing glass should be cleaned after they have been cut to size. They can be imprinted with the grid pattern and alignment crosshairs using an indelible drafting ink. The grid pattern may be drawn on drafting paper, then the

grid glass can be placed over the drawing, secured by tape, and the grid pattern copied. If additional grid spaces or a different grid configuration is desired, a proportional divider can be used to maintain uniform grid cell size. When mounting the grid in the assembly, it is important to position the viewing glass with the inscribed grid and crosshairs facing inward, toward the prism. This will prevent the grid and crosshairs from wear and possible obliteration during field use. After the grid and viewing glass are in position, the remaining side plate can be aligned and fastened, adjusting the individual plates for a tight fit.

The circular level bracket can be constructed from scrap metal, cut and drilled to fit flush against the base plate. The bracket is then fastened by tightening the wooden handle on the lag screw. The circular level can be permanently attached to the level bracket with durable waterproof glue. When the canopy cover instrument has been completely assembled, it should be given a coat of polyurethane varnish (or similar coating material) to protect the hardwood and to waterproof the instrument.

Canopy cover calculations consist of counting the number of cells within the grid in which canopy appears, dividing this number of cells by the total number of grid cells, and multiplying by 100 to obtain a percent canopy cover value. Individual canopy cover measurements can be taken at each survey point and averaged to obtain a mean value at the discretion of the individual. Measurements can be made rapidly and require only the proper orientation of the circular level and alignment of the grid and viewing glass crosshairs. Crosshair alignment assures that the canopy cover is determined in a consistent manner while viewing the instrument at eye level, from the same position for each measurement.

Field testing has shown this optical instrument to have several advantages such as small size and lightweight design, ease of use and portability in the field, ruggedness and durability based on field use, and easy construction from locally available, low cost parts. The optical canopy cover instrument described here was used in the field over 3 years and

proved to be an accurate, efficient method of obtaining canopy cover data.

The unit also was found to function as an optical ground cover grid when held in an inverted position. Investigations have shown that the unit can be used successfully for this purpose during a survey. It was found to produce data that was closely comparable to open frame ground cover plots of approximately the same size taken from the same sampling point. Before this use is contemplated, however, the individual must measure (with the aid of an assistant) the actual size of the ground area covered by the grid glass when held at eye level in an inverted position. After this area is known, one must be careful to maintain the instrument at a uniform elevation above the ground surface and at a uniform distance from the eye to obtain consistent results.

The optical canopy cover instrument described will aid individuals who must make canopy cover measurements in the field and who have not been satisfied with the time required or results obtained using other methods. These individuals may find the simplicity and durability of this instrument a benefit to their field investigations without the sacrifice of significant time or expense.

LITERATURE CITED

- Avery, T. E. 1975 Natural resource measurements. McGraw Hill, New York. 339 pp.
- Buell, J. H. 1936 Crown mapping simplified by the use of an Abney level and a mirror. *J. Forest.* 34: 77-78.
- Buell, M. F. and J. E. Cantlon 1950 A study of two communities of the New Jersey pine barrens and a comparison of methods. *Ecology* 31: 567-586.
- Eber, W. 1972 Über das Lichtklima von Wäldern bei Göttingen und seinen Einfluss auf die Bodenvegetation. *Scripta Geobot.* 3: 150.
- Evans, G. C. and D. E. Coombe 1959 Hemispherical and woodland canopy photography and the light climate. *J. Ecol.* 47: 103-113.
- Garrison, G. A. 1949 Uses and modifications for the "Moosehorn" crown closure estimator. *J. Forest.* 47: 733-735.
- Holdsworth, R. P., James D. Curtis and Daniel McCleary 1936 The reflecting crownmeter. *J. Forest.* 34: 528-530.
- Morrison, R. G. and G. A. Yarranton 1970 An instrument for rapid and precise point sampling of vegetation. *Canadian J. Bot.* 48: 293-297.
- Mueller-Dombois, Dieter and Heinz Ellenberg 1974 Aims and methods of vegetation ecology. John Wiley & Sons, New York. 547 pp.
- Robinson, M. W. 1947 An instrument to measure forest crown cover. *Forest. Chron.* 23: 222-225.
- Shepperd, W. D. 1973 An instrument for measuring tree crown width. U.S.D.A. Forest Serv. Res. Note, RM-229. 3 pp.