



**Aalborg Universitet**

**AALBORG UNIVERSITY**  
DENMARK

## **Development of a new controller for simultaneous heating and cooling of office buildings**

Maccarini, Alessandro; Afshari, Alireza; Hultmark, Göran; Bergsøe, Niels Christian; Vorre, Anders

*Published in:*

IAQVEC 2016 - Proceedings of 9th International Conference on Indoor Air Quality Ventilation & Energy Conservation in Buildings

*Creative Commons License*  
Unspecified

*Publication date:*  
2016

*Document Version*  
Publisher's PDF, also known as Version of record

[Link to publication from Aalborg University](#)

*Citation for published version (APA):*

Maccarini, A., Afshari, A., Hultmark, G., Bergsøe, N. C., & Vorre, A. (2016). Development of a new controller for simultaneous heating and cooling of office buildings. In *IAQVEC 2016 - Proceedings of 9th International Conference on Indoor Air Quality Ventilation & Energy Conservation in Buildings : Healthy and Smart Built Environment* [Paper #1444]

### **General rights**

Copyright and moral rights for the publications made accessible in the public portal are retained by the authors and/or other copyright owners and it is a condition of accessing publications that users recognise and abide by the legal requirements associated with these rights.

- ? Users may download and print one copy of any publication from the public portal for the purpose of private study or research.
- ? You may not further distribute the material or use it for any profit-making activity or commercial gain
- ? You may freely distribute the URL identifying the publication in the public portal ?

### **Take down policy**

If you believe that this document breaches copyright please contact us at [vbn@aub.aau.dk](mailto:vbn@aub.aau.dk) providing details, and we will remove access to the work immediately and investigate your claim.

## **Development of a new controller for simultaneous heating and cooling of office buildings**

Alessandro Maccarini<sup>1,\*</sup>, Alireza Afshari<sup>1</sup>, Göran Hultmark<sup>2</sup>, Niels C. Bergsøe<sup>1</sup>, Anders Vorre<sup>2</sup>

<sup>1</sup>Danish Building Research Institute, Aalborg University, Copenhagen, Denmark

<sup>2</sup>Lindab Comfort A/S, Farum, Denmark

\* *Corresponding email: alm@sbi.aau.dk*

### **ABSTRACT**

This paper aims to develop a new controller to regulate the supply water temperature of a room-temperature loop integrated in a novel HVAC for office buildings.

The main feature of the room-temperature loop is its ability to provide simultaneous heating and cooling by circulating water with a temperature of about 22 °C. Therefore, the same supply water temperature is delivered to all the thermal zones in the building, no matter whether a single zone needs heating or cooling. In previous studies, the supply water temperature varied between 20 °C and 23 °C, according to outdoor air temperature. However, a dependency with the outdoor air temperature showed some limitations in terms of energy use and indoor thermal comfort.

A new controller for the supply water temperature was developed in Dymola, a modelling and simulation environment based on the open Modelica language. The controller was fed by signals of actual room air temperatures and return water temperature. Depending on the minimum and maximum air temperatures in the rooms, the supply water temperature was set by adjusting the return water temperature with two offsets, one for heating demand and one for cooling demand.

The behaviour of the controller was tested by modelling two office rooms connected to the room-temperature loop. Standard internal heat gains and construction thermal properties were selected. To evaluate potential energy savings, the new controller was compared with the simple controller previously developed. Simulations with Dymola showed that energy savings of approximately 44% were achieved for both the winter and summer day thanks to the integration of the new controller.

### **KEYWORDS**

Energy savings, HVAC control, room-temperature loop, Modelica, active beam

### **INTRODUCTION**

With the increase of energy use in buildings, energy saving strategies have become a priority in environmental engineering studies. Heating, ventilation and air-conditioning (HVAC) systems represent the largest energy end-use both in residential and commercial buildings, accounting for almost half the energy used in buildings (Pérez-Lombard et al. 2008). It is clear that the challenge facing engineers and researchers is to design innovative HVAC systems able to achieve sufficient levels of indoor climate quality while reducing energy use.

Previous studies conducted by the authors investigated the energy performance of a novel HVAC system for heating and cooling of office buildings. Active beams were integrated into the system as terminal units (Solus active beam, 2014)

The main feature of the novel HVAC system is its ability to provide simultaneous heating and cooling by circulating water through a room-temperature loop. Supply water temperature of

about 20-23 °C is delivered to all the thermal zones in the building, no matter whether a single zone needs heating or cooling. This approach differs from traditional systems where simultaneous heating and cooling demand is provided by operating two separated water circuits with constant supply water temperatures and varying water mass flow rates. Evidently, the supply water temperature is a crucial parameter to be controlled for the development of an efficient design of the room-temperature loop in the novel HVAC system. The energy performance of the novel system was previously estimated by simulation-based studies using traditional building performance simulation programs. Afshari et al. (2013) analyzed the system by using BSim, a program for calculating indoor climate conditions and energy demands in buildings (BSim, 2013). Maccarini et al. (2014) used EnergyPlus to study the energy performance of the system (EnergyPlus v.8.0.0, 2013). Among some general limitations in modelling only one water circuit for both heating and cooling, these programs showed also key limitations in modelling the controller for the supply water temperature. In BSim, the supply water temperature was set by using pre-defined schedules for different periods of the year. A mean water temperature of 22 °C, 21.5 °C and 21 °C was selected respectively for the winter, spring/autumn and summer. Simulations with EnergyPlus allowed a wider understanding of the energy behavior of the system. This was mainly due to the possibility of modelling an Energy Management System program (EMS). EMS is an advanced feature of EnergyPlus and it provides a way to develop custom control and modelling routines for EnergyPlus models. The EMS program had the aim to set the supply water temperature as a function of the outdoor air temperature, as illustrated in Figure 1. However, none of these approaches represented an optimal solution since they were not able to track the actual thermal needs of the building.

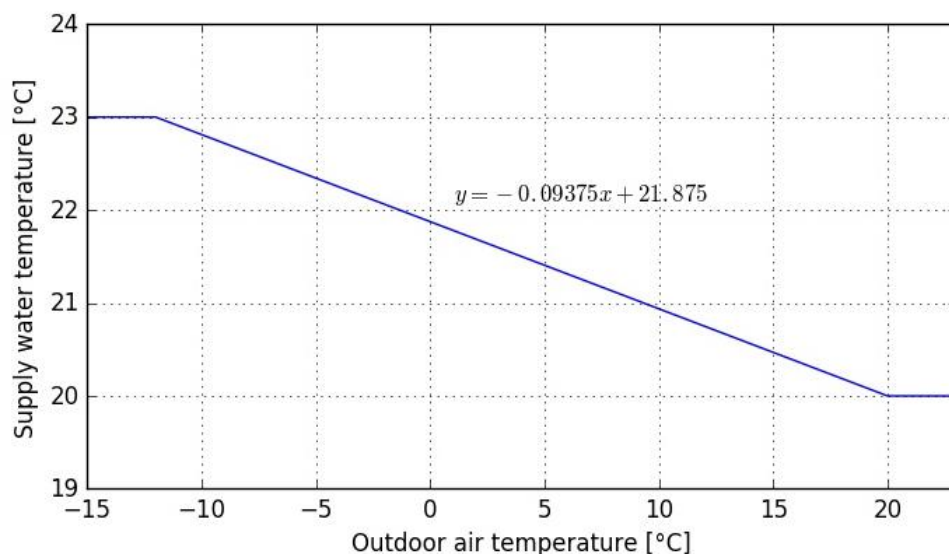

Figure 1. Supply water temperature as function of the outdoor air temperature

Thus, a more flexible modeling tool is needed to develop an efficient controller. Therefore, the main goal of this paper is to model a controller for the regulation of the supply water temperature of the room-temperature loop with Dymola, a simulation environment based on the Modelica language. The behavior of the new controller was tested on two office rooms and compared with the simple controller previously developed.

## METHODS

### Concept of the room-temperature loop

As previously mentioned, the main feature of the novel HVAC system is its ability to provide simultaneous heating and cooling by circulating water through a room-temperature loop. Supply water temperature of about 22 °C is delivered to all the thermal zones in the building. Outlet water from the zones is mixed together and as a result the system only has to cool or heat the water to reach the supply temperature once again. The overall effect is that the system is able to distribute the excess heat from warm zones to cold zones when simultaneous heating and cooling demand occurs in the building.

The system was modelled by using basic components of the Modelica *Buildings* library (Wetter et al. 2014), a free open-source library with dynamic simulation models for building energy and control systems.

### Modeling of the two-zone building

The behavior of the system was studied by its integration into a two-zone building model made of one perimeter zone and one core zone. Both rooms had the same dimensions: 4 m length, 4 m width and 3 m height. The perimeter zone consisted of an external wall facing north with a double pane window of 3.6 m<sup>2</sup>. No external walls were included in the core zone. Both rooms had a roof and a floor. Internal walls were considered adiabatic. Table 1 shows the thermal properties of the construction elements.

Table 1. Thermal properties of the construction elements. SHGC stands for solar heat gain coefficient

Construction element	U-value [W/m <sup>2</sup> K]
External wall	0.31
Roof	0.18
Floor	1.83
Window (SHGC=0.4)	2.37

Infiltration rate was set to 0.08 ACH for the perimeter zone. Internal heat gains were selected to be 8.83 W/m<sup>2</sup> for lighting, 8 W/m<sup>2</sup> for equipment and 6.46 W/m<sup>2</sup> for occupants during working hours (7 AM-6 PM). It is worth mentioning that the values of the thermal properties for construction elements and internal heat loads were defined according to the medium office building model prototype described in (Deru et al. 2011) and developed in accordance with the design and construction requirements of AHSRAE standard 90.1-2013. The weather conditions of Copenhagen (Denmark) were chosen for simulations.

### Modeling of the HVAC system

The schematic diagram of the novel system is shown in Fig. 2. It consists of a room-temperature water loop for space heating and cooling and one air circuit for ventilation. One active beam unit was installed in each room to provide heating, cooling and ventilation. A constant water mass flow rate of 0.038 kg/s per each beam was provided by a pump. An ideal heater/cooler was responsible to provide energy to the return water flow to reach the supply temperature set-point. The water system turned on two hours before the beginning of the working day (5 AM) and turned off two hours after (8 PM).

The ventilation system consisted of an air handling unit (AHU) made of a fan and two heat exchangers. The latter aimed to maintain a constant supply air temperature of 19 °C. The fan supplied a constant air mass flow rate of 0.026 kg/s per each beam during working hours. A

heat recovery unit with efficiency of 0.9 pre-heated outdoor air. The air mass flow rate was reduced by half during non-working hours.

Table 2 summarizes the parameters used in the simulations. The values were chosen according to the recommended design values described in the REHVA chilled beam application guidebook (Virta et al. 2004) and manufacturer's recommendations.

Table 2. Design parameters for the active beam units

Parameter	Value
Supply water temperature	20-23 °C
Water mass flow rate per beam	0.038 kg/s
Supply air temperature	19 °C
Air mass flow rate per beam	0.03 kg/s
Air pressure drop	100 Pa
Water pressure drop	35 kPa
Beam length	2.8 m

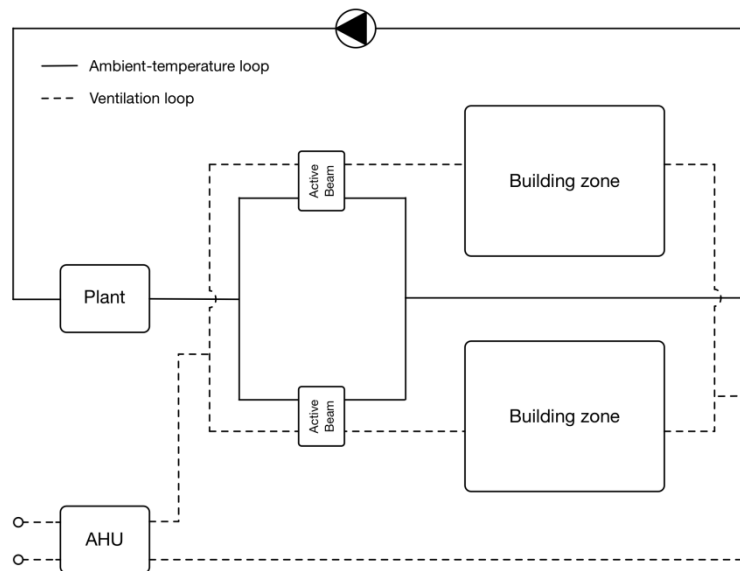

Figure 2. Schematic diagram of the novel HVAC system

### Supply water temperature controller

As previously mentioned, the system is able to simultaneously provide heating and cooling to the building. Therefore, the supply water should have temperature levels similar to indoor thermal comfort conditions.

In order to meet heating loads in winter and cooling loads in summer, the supply water temperature varied approximately between 20 °C and 23 °C during working hours. The controller was developed by using basic components of the Modelica Standard Library (MSL). The controller was designed to track indoor air temperatures in the rooms and set a proper supply water temperature. Fig. 3 shows a diagram of the controller developed in Dymola. The supply water temperature can be expressed by the following equation:

$$T_{sup} = T_{ret} + k_{hea} - k_{coo} \quad (1)$$

Where  $T_{ret}$  is the return water temperature and  $k_{hea}$  and  $k_{coo}$  are offsets able to adjust the return water temperature based on current air temperatures in the rooms and set-point temperatures. The controller is fed by the signals of actual air temperatures in the rooms and return water temperature. The block *MinMax* evaluates the minimum and maximum air temperature among the five rooms. The minimum temperature is an input for the block *PIDhea*, where it is compared with the heating temperature set-point. If the minimum air temperature is above the set-point,  $k_{hea}$  is equal to 0. Otherwise, the PID controller evaluates the value of  $k_{hea}$  to be added to  $T_{ret}$  to meet the heating set-point. The maximum temperature is an input for the block *PIDcoo*, where it is compared with the cooling temperature set-point. If the maximum air temperature is below the set-point,  $k_{coo}$  is equal to 0. Otherwise, the PID controller evaluates the value of  $k_{coo}$  to be deducted from  $T_{ret}$  to meet the cooling set-point. As a consequence, whenever both room air temperatures are within the heating and cooling set-point range,  $k_{hea}$  and  $k_{coo}$  are equal to 0 and, therefore, the supply water temperature is set equal to the return water temperature, requiring for no energy in the ideal plant. Heating set-point temperatures were set at 16 °C and 20 °C respectively for non-operating and operating hours. Cooling set-point temperatures were set at 27 °C and 24 °C respectively for non-operating and operating hours.

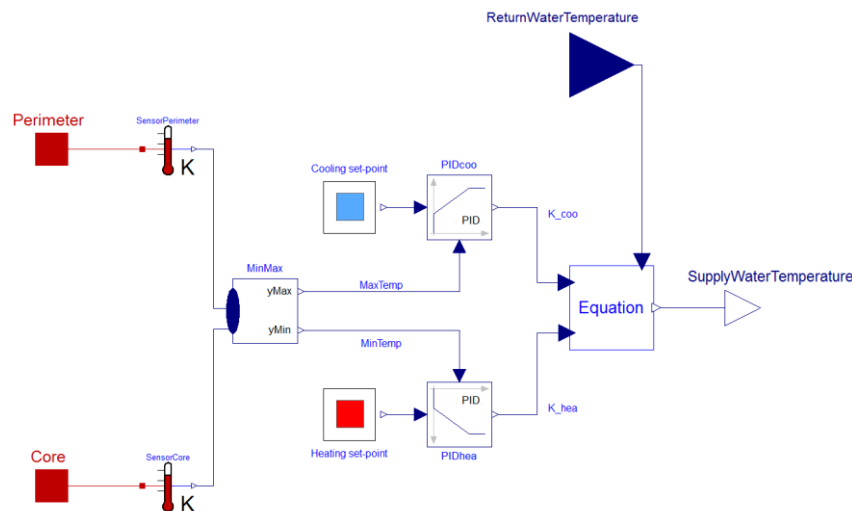

Figure 3. Layout of the new controller developed in Dymola

## RESULTS AND DISCUSSION

To evaluate the efficacy of the controller, its performance was compared with the one of the simple controller in terms of energy use and thermal comfort conditions in the office rooms. Dynamic simulations were run for both models for a typical winter and summer day.

Figure 4 shows the room air temperatures and supply and return water temperature for the typical winter day. It can be noticed that both controllers are able to maintain air temperature levels in the rooms within the range 20-24 °C during operating hours. The simple controller presents supply water temperature almost always above the return water temperature. Therefore, heating energy is required by the ideal plant for most of the hours. In the middle of the day, a little amount of cooling is provided. Conversely, the new controller is able to set the supply water temperature equal to the return water temperature for all the operating hours, unless for few hours at the beginning of the day. This means, that very little energy is required by the central plant. Generally, similar values of the air temperatures are noticed when comparing the two controllers. Figure 5 shows the room air temperatures and supply and return water temperature for the typical summer day.

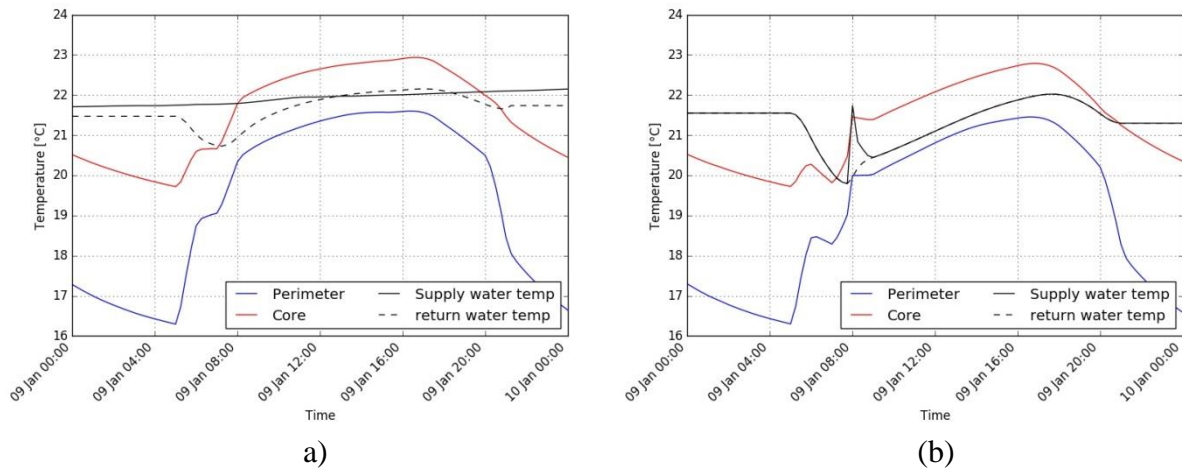

Figure 4. Temperatures for the typical winter day. a) Simple, b) New controller

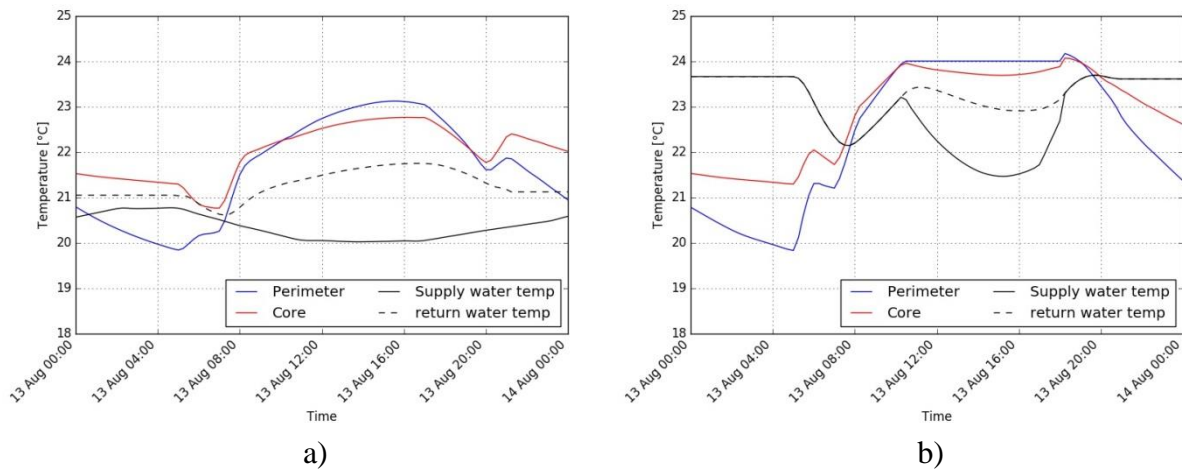

Figure 5. Temperatures for the typical summer day. a) Simple, b) New controller

Both controllers are able to maintain air temperature levels in the rooms within the range 20-24 °C during operating hours. It can be noticed that the simple controller has the attitude to set the supply water temperature at a value close to the minimum of 20 °C, even if the air temperatures in the rooms are significantly lower than the cooling set-point. This is because the simple controller sets the supply water temperature as a function of the external air temperature. There is no track of the actual thermal needs of the rooms. As a result, the simple controller is over-cooling the rooms and wasting energy. In addition, such indoor air temperatures seem to be slightly too cold for thermal comfort conditions in the summer.

Conversely, the new controller sets the supply water temperature by adjusting the return water temperature just enough to meet the set-point temperature of 24 °C.

Figure 6 shows the energy use of the novel HVAC system for both controllers for the typical winter and summer day. When the system integrated the simple controller, the energy use was 2.5 kWh and 6.3 kWh, respectively, for the winter and summer day. When the system integrated the new controller, the energy use was 1.4 kWh and 3.5 kWh, respectively, for the winter and summer day. This means that the integration of the new controller lead to energy savings of approximately 44% for both the winter and summer day. Therefore, with the development of the new controller, it was possible to significantly increase the energy performance of the novel HVAC system.

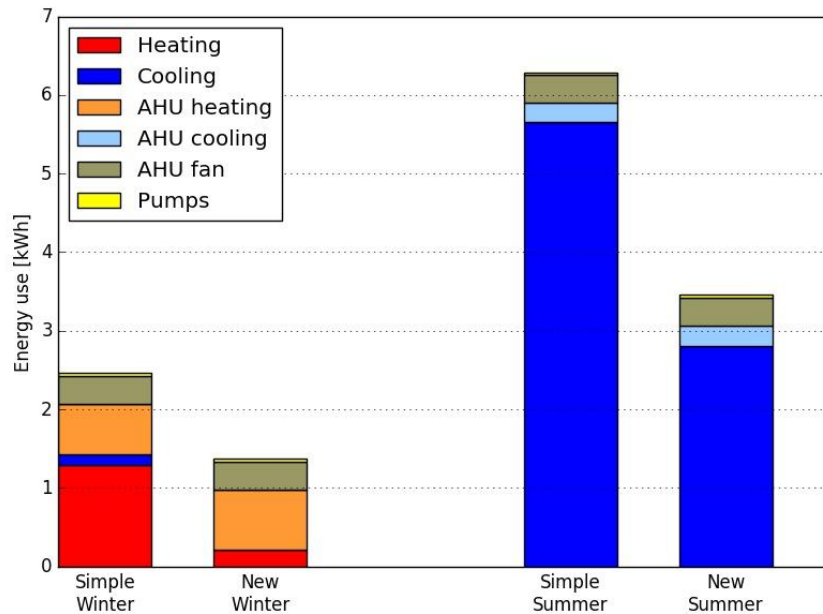

Figure 6. Total energy use for the two controllers for a typical winter and summer day

## CONCLUSION

This paper aimed to present the development of a new controller for the regulation of the supply water temperature of a novel HVAC system. The controller was developed with Dymola, a modelling and simulation environment based on the open Modelica language. The use of Modelica allowed to overcome the limitations occurred in previous studies where traditional building performance simulation programs were used.

The efficacy of the new controller was tested through its integration into a two-zone building for a typical winter and summer day. To evaluate energy savings potential, the energy performance of the new controller was compared with the one of a simple controller previously developed.

The results from the simulations show that the new controller was able to meet heating and cooling set-point temperatures in both typical days. Energy savings of approximately 44% were achieved when comparing the simple and the new controller. This was mainly due to the ability of the new controller in setting a supply water temperature that required the minimum amount of energy to meet the set-point temperatures. In addition, the integration of the new controller avoided situation of over-cooling during the summer day. This paper also show that the integration of advanced control strategies into basic HVAC systems can lead to significant improvements in terms of energy efficiency.

Further studies will involve the modeling of the novel HVAC system integrated into an entire office building model and simulated for a one-year period. In addition, a real implementation of the novel HVAC system is currently under development in an office building situated in Sweden. This will provide the possibilities for further investigations on energy performance, indoor thermal comfort and cost estimation.

## ACKNOWLEDGEMENT

This study was financially supported by ELFORSK, a research and development program administrated by the Danish Energy Association. The authors would like to thank Michael Wetter from the Lawrence Berkeley National Laboratory for his support.



## REFERENCES

- Afshari, Alireza, Rouzbeh G Norouzi, Göran Hultmark, and Niels C Bergsøe. 2013. Two-Pipe Chilled Beam System for Both Cooling and Heating of Office Buildings. In *11th REHVA World Congress and 8th International Conference on Indoor Air Quality, Ventilation and Energy Conservation in Buildings*, 16–19 June, 2013, Prague, Czech Republic.
- BSim - Building Simulation. <http://sbi.dk/en/bsim>.
- Deru, Michael, Kristin Field, Daniel Studer, Kyle Benne, Brent Griffith, Paul Torcellini, Bing Liu, et al. 2011. U.S. Department of Energy Commercial Reference Building Models of the National Building Stock.
- EnergyPlus. <https://energyplus.net/>.
- Maccarini, Alessandro, Alireza Afshari, Niels C Bergsøe, Göran Hultmark, Magnus Jacobsson, and Anders Vorre. 2014. Innovative Two-Pipe Active Chilled Beam System for Simultaneous Heating and Cooling of Office Buildings. In *13th International Conference on Indoor Air Quality and Climate*, 7–12 July, 2014, Hong Kong.
- Pérez-Lombard, Luis, José Ortiz, and Christine Pout. 2008. A Review on Buildings Energy Consumption Information. *Energy and Buildings* 40 (3): 394–98.
- Supply Air Beam Solus. 2014.
- Virta, Maija, David Butler, Jonas Gräslund, Jaap Hogeling, Erik Kristiansen L., Mika Reinikainen, and Gunnar Svensson. 2004. *Chilled Beam Application Guidebook*. REHVA.
- Wetter, Michael, Wangda Zuo, Thierry S. Noudui, and Xiufeng Pang. 2014. Modelica Buildings Library. *Journal of Building Performance Simulation* 7 (4): 253–70.