



**AALBORG UNIVERSITY**  
DENMARK

**Aalborg Universitet**

## **Stability Analysis and Controller Synthesis for Single-Loop Voltage-Controlled VSIs**

Wang, Xiongfei; Loh, Poh Chiang; Blaabjerg, Frede

*Published in:*  
I E E E Transactions on Power Electronics

*DOI (link to publication from Publisher):*  
[10.1109/TPEL.2016.2632065](https://doi.org/10.1109/TPEL.2016.2632065)

*Publication date:*  
2017

*Document Version*  
Accepted author manuscript, peer reviewed version

[Link to publication from Aalborg University](#)

*Citation for published version (APA):*  
Wang, X., Loh, P. C., & Blaabjerg, F. (2017). Stability Analysis and Controller Synthesis for Single-Loop Voltage-Controlled VSIs. *I E E E Transactions on Power Electronics*, 32(9), 7394 - 7404 .  
<https://doi.org/10.1109/TPEL.2016.2632065>

### **General rights**

Copyright and moral rights for the publications made accessible in the public portal are retained by the authors and/or other copyright owners and it is a condition of accessing publications that users recognise and abide by the legal requirements associated with these rights.

- ? Users may download and print one copy of any publication from the public portal for the purpose of private study or research.
- ? You may not further distribute the material or use it for any profit-making activity or commercial gain
- ? You may freely distribute the URL identifying the publication in the public portal ?

### **Take down policy**

If you believe that this document breaches copyright please contact us at [vbn@aub.aau.dk](mailto:vbn@aub.aau.dk) providing details, and we will remove access to the work immediately and investigate your claim.

# Stability Analysis and Controller Synthesis for Single-Loop Voltage-Controlled VSIs

Xiongfei Wang, *Member IEEE*, Poh Chiang Loh, and Frede Blaabjerg, *Fellow IEEE*

**Abstract**—This paper analyzes the stability of digitally voltage-controlled Voltage-Source Inverters (VSIs) with the linear voltage regulators. It is revealed that the phase lags, caused by using the resonant controller and the time delay of a digital control system, can stabilize the single-loop voltage control without damping of the LC-filter resonance. The stability region for the digital single-loop resonant voltage control is then identified, considering the effects of different discretization methods for the resonant controller. An enhanced voltage control approach with a widened stability region is subsequently proposed, and a step-by-step design method of the proposed controller is developed based on the root contours in the discrete  $z$ -domain. Simulations and experimental tests of a 400-Hz VSI system validate the stability analysis and the performance of the proposed control approach.

**Index Terms**—Time delay, stability, voltage-source inverters, voltage control

## I. INTRODUCTION

THE voltage-controlled Voltage-Source Inverter (VSI) with an LC-filter have commonly been used for uninterruptible power supplies [1], [2], distributed generation systems [3], and other high-performance ac power sources, e.g. grid emulators [4] and power amplifiers in the hardware-in-the-loop tests [5]. A stable ac voltage with high waveform-quality is demanded in these applications. To meet the requirements, a wide variety of voltage control schemes have thus been developed, which are, in general, categorized into two groups in respect to the control structure, i.e. the double-loop voltage-current control [6]-[8], [12], and the single-loop voltage control [9]-[11].

The double-loop control schemes are composed by an inner current loop based on feeding back the LC-filter inductor- or capacitor-current, and an outer voltage loop for controlling the filter capacitor voltage [6]. It has been shown that the inner loop can be equivalent to a virtual impedance, which is in series with the filter inductor or capacitor, corresponding to the feedback of filter inductor- or capacitor-current [7]. Besides the damping of the LC-filter resonance, the virtual impedance has also been used to decouple the resonant poles of the LC-filter in order to improve the dynamic performance of the voltage control [12]. However, the virtual impedance only works well when the time delay of digital control has a negligible phase lag effect [11]. Considering the one sampling period ( $T_s$ ) of digital computation

delay and the Zero-Order Hold (ZOH) effect of the digital Pulse Width Modulation (PWM) [14]-[16], the virtual impedance exhibits a negative real part above the one-sixth of the sampling frequency ( $f_s/6$ ). As a consequence, a negative damping is added into the system above  $f_s/6$ , which not only constrains the control bandwidth of the inner current loop [11], but it may also degrade the voltage control performance [10].

For the VSIs with a high pulse-ratio, namely the ratio of the switching to fundamental frequency, the critical frequency,  $f_s/6$  is usually far above the fundamental frequency and low-order harmonic frequencies. The double-loop voltage control allows for a high-performance double-loop voltage control. However, for the VSIs with a low pulse-ratio, either the very high power VSIs with 50-Hz outputs [4] or the 400-Hz ground power units [10], [11], the low-order harmonic frequencies may be close to or even above the critical frequency,  $f_s/6$ . A negative damping will thus be synthesized by the inner loop at certain harmonic frequencies, which challenges the controller design of the outer voltage loop. Therefore, the double-loop control schemes can hardly fulfill the voltage waveform-quality requirement for the low-pulse-ratio VSIs [10], [11].

The single-loop voltage control schemes are thus preferred for low-pulse-ratio VSIs [9]-[11]. In order to mitigate the effect of the LC-filter resonance, the direct pole placement method based on the discrete  $z$ -domain model of VSIs has been reported in [9], [10]. It exhibits a better dynamic performance than the double-loop control schemes, but does also make the system sensitive to the variations of system parameters. To overcome this drawback, a single-loop Resonant (R) control scheme was developed in [11]. Instead of the Proportional + Integral (PI) or P + Resonant (PR) controllers, only the R controllers tuned at the fundamental frequency and low-order harmonic frequencies are adopted to regulate the output voltage with high waveform-quality. However, the stabilization mechanism underlying this control approach is not explained. Moreover, the effects of the discretization methods for the R controller are also overlooked. Hence, the stability region of the single-loop R control is still not identified.

This paper thus presents first an in-depth stability analysis of the single-loop voltage control with the linear P or R regulators. The effects of digital computation and modulation delays on the system stability are analyzed for the single-loop P or R voltage control schemes. The critical frequency, above which the non-negative Phase Margin (PM) can be preserved, is found in each case. The stability region for the single-loop R voltage control is identified, where the effects of discretization methods applied to the R controller is also considered. Moreover, it is found that

This work was supported by European Research Council (ERC) under the European Union's Seventh Framework Program (FP7/2007-2013)/ERC Grant Agreement no. [321149-Harmony].

X. Wang, P. C. Loh, and F. Blaabjerg are with the Department of Energy Technology, Aalborg University, 9220 Aalborg East, Denmark (e-mail: xwa@et.aau.dk, pcl@et.aau.dk, fbl@et.aau.dk).

the R controller gain is also affected by the output fundamental frequency, when the fundamental frequency approaches to the phase crossover frequency of the control loop, i.e. the frequency for the phase response crossing over  $-\pi$ . This effect complicates the tuning of the R controller gain.

Then, an enhanced single-loop voltage control scheme with the widened stability region is proposed in this work. In this method, instead of using R controllers only, the basic integrator '1/s' is inserted in series with a PR controller. The R part of the PR controller is merely used for zero steady-state tracking error. The system dynamics are determined by the P controller, whose value is, unlike the single-loop R control scheme, independent on the fundamental frequency, and thus facilitates the parameter tuning. Moreover, a damping controller based on a negated low-pass filter is added in the capacitor voltage loop, which widens the stability region compared to that of the single-loop R control. A holistic design procedure for controller parameters is further developed based on the root contours in the discrete  $z$ -domain. Simulations and experimental tests of a 400-Hz VSI system are performed. The results confirm the effectiveness of the theoretical analysis and the performance of the proposed approach.

## II. STABILITY OF VOLTAGE-CONTROLLED VSIS

### A. System Description

Fig. 1 illustrates a simplified single-line diagram of a three-phase voltage-controlled VSI with an LC-filter. The ac voltage across the filter capacitor is controlled with either the single- or double-loop control structure, and the filter inductor current is controlled as an inner loop in the double-loop control structure. The main circuit parameters of the VSI are provided in Table I. A constant dc-link voltage  $V_{dc}$  is assumed, and hence the LC-filtered VSI can be modeled as a linear time-invariant system in the stationary frame [13].

Fig. 2 shows the block diagrams of the digital single- and double-loop voltage control schemes, where the delay response of the digital PWM is modeled by the ZOH effect [14]-[16], and the one sampling period of computational delay ( $z^{-1}$ ) is included [15]. The total time delay, in the continuous  $s$ -domain, can thus be denoted by  $G_d(s)$ , which is given by

$$G_d(s) = e^{-1.5T_s s} \quad (1)$$

where  $T_s$  is the sampling period of the digital control system. In the double-loop voltage control scheme given in Fig. 2(b), the P controller,  $k_c$  is used with the inner current loop, while the PR controller is used for the voltage regulation in the outer voltage loop.

### B. Double-Loop Voltage Control

Fig. 3 depicts the block diagram of the double-loop voltage control scheme in the continuous  $s$ -domain and its equivalent diagram. By redrawing the inner current loop, the equivalent diagram given in Fig. 3(b) illustrates that the inner loop can be equivalent to a virtual impedance  $Z_v(s)$  in series with the filter inductor.  $Z_v(s)$  is given by

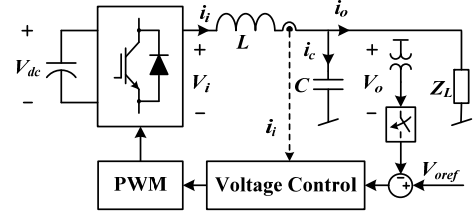

Fig. 1. Simplified single-line diagram of a three-phase voltage-controlled VSI with an LC-filter.

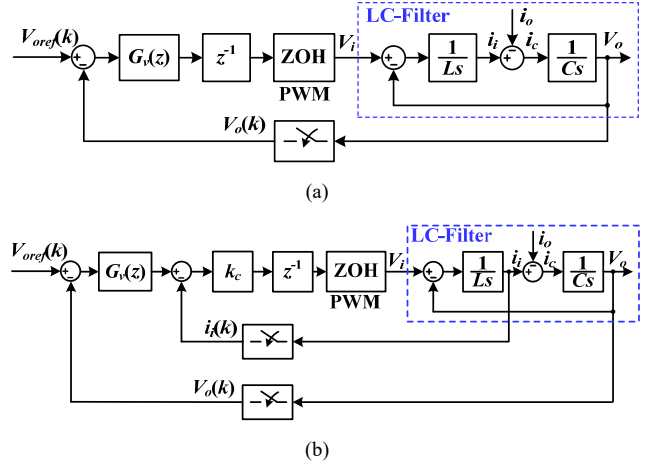

Fig. 2. Block diagrams of single- and double-loop voltage control schemes. (a) Single-loop voltage control. (b) Double-loop voltage control.

$$Z_v(s) = k_c e^{-1.5T_s s} \quad (2)$$

which is, by applying the Euler's formula, equivalent to

$$Z_v(j\omega) = k_c [\cos(1.5\omega T_s) - j \sin(1.5\omega T_s)] \quad (3)$$

From (3), it is noted that the real part of the virtual impedance  $Z_v(j\omega)$  is frequency dependent. It becomes negative between  $f_s/6$  and the Nyquist frequency  $f_s/2$ . On the other hand, if the delay  $G_d(s)$  is ignored,  $Z_v(s)$  turns as a pure resistance ( $Z_v(s) = k_c$ ). The insertion of the negative damping resistance leads to an unstable open-loop gain and the consequent non-minimum closed-loop

TABLE I  
MAIN CIRCUIT PARAMETERS

Symbol	Electrical Constant	Value
$V_o$	AC output voltage	400V
$f_1$	AC output fundamental frequency	50 Hz
$f_{sw}$	Inverter switching frequency	10 kHz
$f_s$	Control sampling frequency	10 kHz
$V_{dc}$	Inverter DC-link voltage	730 V
$L$	LC-filter – filter inductor	1.5 mH
$C$	LC-filter – filter capacitor	10 $\mu$ F
$Z_L$	Resistive load	254 $\Omega$
$Z_{R-L}$	Series R-L load – resistance (R)	134 $\Omega$
	Series R-L load – inductance (L)	78 mH
$Z_{R/C}$	Parallel R/C load – resistance (R)	254 $\Omega$
	Parallel R/C load – capacitance (C)	4.4 $\mu$ F

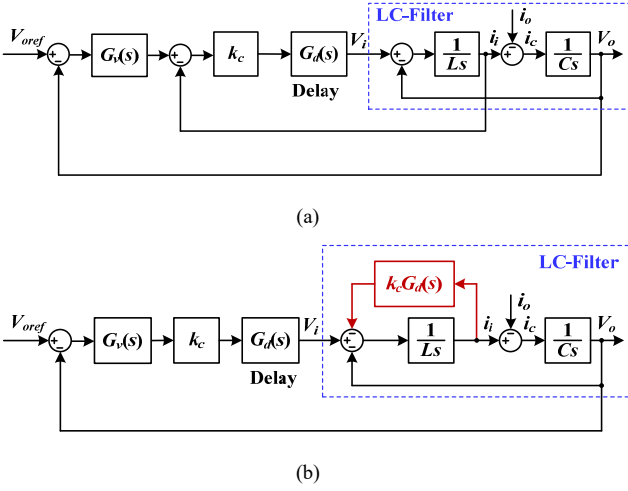

Fig. 3. Block diagram of double-loop voltage control in the continuous  $s$ -domain and its equivalent diagram. (a) Double-loop voltage control in the continuous  $s$ -domain. (b) Equivalent diagram of double-loop voltage control.

response of the outer voltage control loop [11].

Moreover, the addition of the integrator, i.e.  $k_{ci}/s$ , in the inner current controller will aggravate the negative damping effect, due to the phase lag of  $\pi/2$  brought by the integrator. This can also be explicitly elaborated by replacing the proportional gain  $k_c$  in (3) with the PI controller, i.e.  $k_c + k_{ci}/s$ , which is given by

$$Z_v(j\omega) = \left( k_c + \frac{k_{ci}}{j\omega} \right) [\cos(1.5\omega T_s) - j \sin(1.5\omega T_s)] \quad (4)$$

The real part of the virtual impedance  $Z_v(j\omega)$  is then changed as

$$\text{Re}\{Z_v(j\omega)\} = k_c \cos(1.5\omega T_s) - \frac{k_{ci}}{\omega} \sin(1.5\omega T_s) \quad (5)$$

where the term  $\cos(1.5\omega T_s)$  becomes negative in the frequency region ( $f_s/6, f_s/2$ ), while the term  $\sin(1.5\omega T_s)$  is kept positive in the region ( $0, f_s/3$ ). Hence, the negative damping effect will be aggravated in the region ( $f_s/6, f_s/3$ ) by using the PI controller. Above the frequency  $f_s/3$ , the coefficient  $k_{ci}/\omega$  tends to be much smaller than  $k_c$ , and thus the term  $\sin(1.5\omega T_s)$  has minor effect on reducing the negative damping in the region ( $f_s/3, f_s/2$ ) [19].

### C. Single-Loop Voltage Control

The single-loop voltage control in the continuous  $s$ -domain can then be drawn in Fig. 4, where  $G_p(s)$  and  $Z_o(s)$  characterize the dynamics of the LC-filter plant, which are transfer functions from the inverter voltage and load current to the output voltage, respectively.

$$G_p(s) = \frac{V_o}{V_{pwm}} \Big|_{i_o=0} = \frac{\omega_r^2}{s^2 + \omega_r^2}, \quad \omega_r = \frac{1}{\sqrt{LC}} \quad (6)$$

$$Z_o(s) = -\frac{V_o}{i_o} \Big|_{V_{pwm}=0} = \frac{s}{C(s^2 + \omega_r^2)} \quad (7)$$

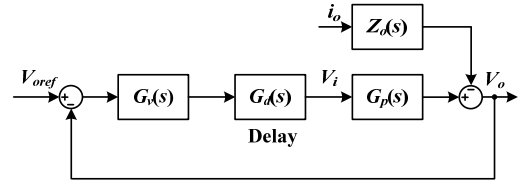

Fig. 4. Single-loop voltage control system in the continuous  $s$ -domain.

where  $\omega_r$  is the LC-filter resonance frequency.

From Fig. 4, the open-loop gain of the voltage loop can be derived as

$$T(s) = G_v(s)G_d(s)G_p(s) \quad (8)$$

Based on (4), the system stability with the P controller used for  $G_v(s)$  is evaluated first in the following. Then, the stability of using the R controller only with  $G_v(s)$ , as reported in [11], is analyzed, and the stability region of the single-loop R voltage control scheme is identified.

#### 1) P Controller

The phase and magnitude of  $T(j\omega)$  with the P controller only, i.e.  $G_v(s) = k_p$ , can be given by

$$\angle T(j\omega) = \begin{cases} -1.5T_s\omega, & \omega < \omega_r \\ -\pi - 1.5T_s\omega, & \omega_r < \omega \end{cases} \quad (9)$$

$$|T(j\omega)| = \frac{k_p}{|1 - LC\omega^2|} \quad (10)$$

For a stable voltage loop with the P controller, the following two conditions can be formulated based on the Nyquist stability criterion:

- $\omega_r$  is above the phase crossover frequency  $\omega_p$  for a positive PM. A critical value of  $\omega_r$ , i.e.  $\omega_c = \omega_s/3$ , can thus be derived, which is illustrated by

$$-1.5T_s\omega_c = -\pi \Rightarrow \omega_c = \frac{\omega_s}{3} \quad (11)$$

- The magnitude of  $T(j\omega)$  is below 0 dB at the phase crossover frequency for a positive Gain Margin (GM).

Fig. 5 plots the bode diagrams of  $T(s)$  for  $f_s = 5$  kHz with the different LC-filter resonance frequencies and  $k_p$  values. It can be seen that the system is stable (GM > 0, PM > 0) in the case of  $C = 5 \mu\text{F}$ ,  $k_p = 0.1$ , owing to  $\omega_r > \omega_s/3$  and  $|T(j\omega)| < 0$  dB at  $\omega_p$ . However, a non-trivial steady-state error is inevitable at the fundamental frequency, and the increase of  $k_p$  will lead to a negative GM, as shown by the case of  $C = 5 \mu\text{F}$ ,  $k_p = 1$ . On the other hand, the decrease of  $\omega_r$  below  $\omega_c$  will result in a negative PM, which is shown in the case of  $C = 10 \mu\text{F}$ .

#### 2) R Controller

Next is to consider the R controller only for  $G_v(s)$  [11], whose basic form is given by

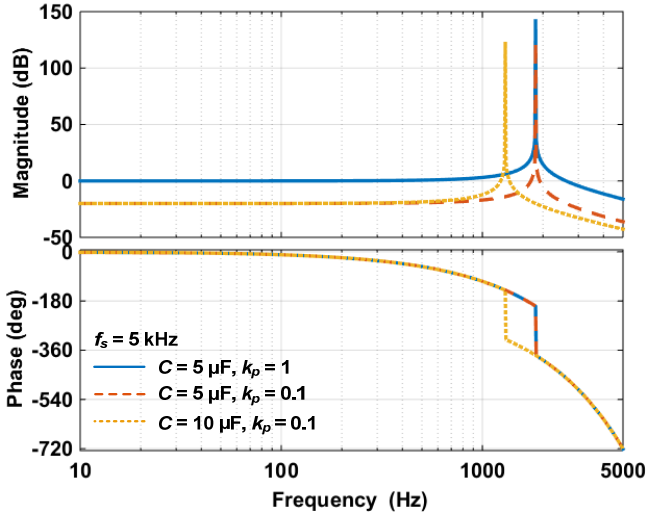

Fig. 5. Bode diagrams of  $T(s)$  with the P controller at  $f_s = 5$  kHz.

$$G_v(s) = k_i R(s), \quad R(s) = \frac{s}{s^2 + \omega_1^2} \quad (12)$$

where  $\omega_1 = 2\pi f_1$  is the output fundamental frequency. The phase and magnitude of  $T(j\omega)$  in this case can be given by

$$\angle T(j\omega) = \begin{cases} \frac{\pi}{2} - 1.5T_s\omega, & \omega < \omega_1 \\ -\frac{\pi}{2} - 1.5T_s\omega, & \omega_1 < \omega < \omega_r \\ -\frac{3\pi}{2} - 1.5T_s\omega, & \omega_r < \omega \end{cases} \quad (13)$$

$$|T(j\omega)| = \left| \frac{k_i\omega}{\omega_1^2 - \omega^2} \cdot \frac{1}{1 - LC\omega^2} \right| \quad (14)$$

From (13), it is noted that a phase lag of  $\pi/2$  is added by the R controller above the fundamental frequency  $\omega_1$ . Consequently, the critical frequency  $\omega_c$  is reduced to  $\omega_s/6$ , which is illustrated by

$$-1.5T_s\omega_c - \frac{\pi}{2} = -\pi \Rightarrow \omega_c = \frac{\omega_s}{6} \quad (15)$$

Also, the controller gain at the phase crossover frequency is changed as

$$\left| \frac{k_i\omega_p}{\omega_1^2 - \omega_p^2} \right| \approx \frac{k_i}{\omega_p}, \quad \text{if } \omega_p \gg \omega_1 \quad (16)$$

which allows  $GM > 0$  to be more readily obtained than the use of P controller given in (10), provided that  $\omega_p \gg \omega_1$ . However, when  $\omega_1$  approaches to  $\omega_p$ , the choice of  $k_i$  will also be affected by  $\omega_1$ , and the system tends to become unstable.

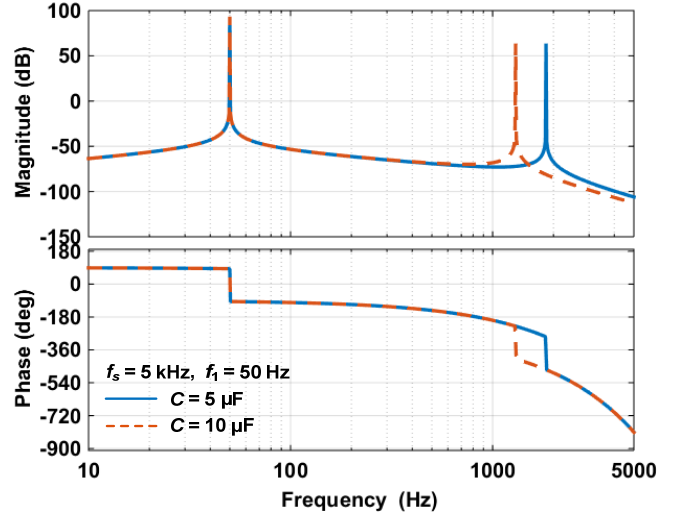

(a)

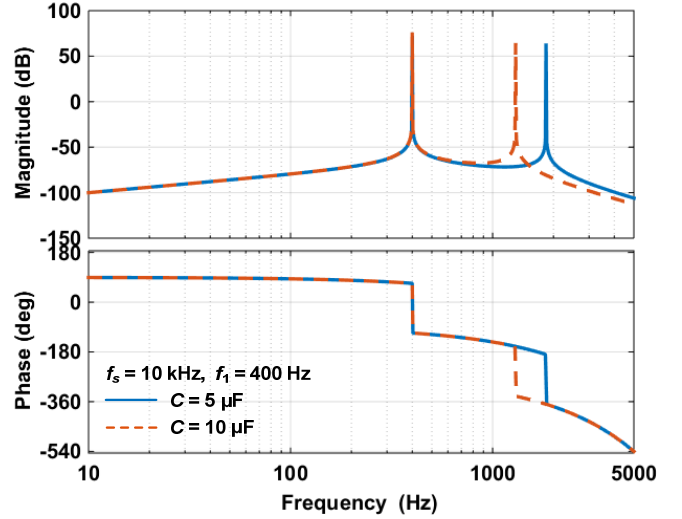

(b)

Fig. 6. Bode diagrams of  $T(s)$  with the unity-gain-R controller, i.e.  $R(s)$ . (a)  $f_s = 5$  kHz,  $f_1 = 50$  Hz. (b)  $f_s = 10$  kHz,  $f_1 = 400$  Hz.

Fig. 6 shows the Bode diagrams of  $T(s)$  with the  $R(s)$  only for  $G_v(s)$ . Two cases with the different sampling and fundamental frequencies are plotted. In the case of  $f_s = 5$  kHz in Fig. 6(a), the LC-filter resonance frequencies  $\omega_r$  for both  $C = 5 \mu\text{F}$  and  $C = 10 \mu\text{F}$  are above  $\omega_s/6$ , and  $|T(j\omega)|$  is below 0 dB except at the frequencies  $\omega_1$  and  $\omega_r$ . The voltage loop can hence be designed with  $PM > 0$  and  $GM > 0$ , and the phase lag of the R controller plays a critical role in stabilizing the system. In contrast, using the P controller can only reduce the phase lag of the R controller and worsen the system stability. Fig. 6(b) shows the frequency responses at  $f_s = 10$  kHz, where  $\omega_r < \omega_s/6$  for  $C = 10 \mu\text{F}$  and the voltage loop cannot be designed as stable ( $PM < 0$ ). This agrees with the critical frequency predicted by (15).

Besides the phase lag of the basic form of the R controller, the discretized R controller may bring in additional time delay affecting the stability region of the voltage loop. Fig. 7 plots the frequency responses of the R controller discretized with three different methods, which are 1) the Tustin transformation with

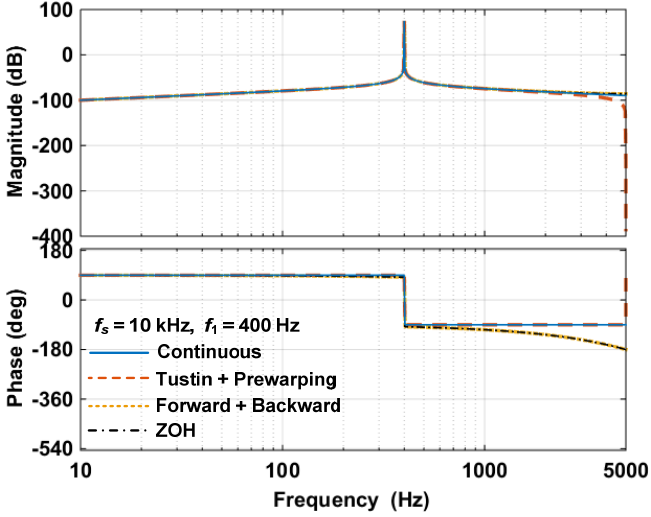

Fig. 7. Frequency responses of the  $R(s)$  with different discretization methods.

the prewarping at  $\omega_1$ , i.e.  $R_{r-p}(z)$ , 2) the two-integrator-based scheme with the forward and backward Euler integrators, which is denoted by  $R_{f-b}(z)$  [17], and 3) the Zero-Order Hold (ZOH) transformation, i.e.  $R_{zoh}(z)$ , which is used in [11]. Their specific discrete forms are, respectively, given below

$$R_{r-p}(z) = \frac{\sin(\omega_1 T_s)}{2\omega_1} \frac{1 - z^{-2}}{1 - 2z^{-1} \cos(\omega_1 T_s) + z^{-2}} \quad (17)$$

$$R_{f-b}(z) = \frac{T_s(z^{-1} - z^{-2})}{1 + z^{-1}(\omega_1^2 T_s^2 - 2) + z^{-2}} \quad (18)$$

$$R_{zoh}(z) = \frac{\sin(\omega_1 T_s)}{\omega_1} \frac{z^{-1} - z^{-2}}{1 - 2z^{-1} \cos(\omega_1 T_s) + z^{-2}} \quad (19)$$

It can be seen that the Tustin with prewarping has no additional phase lag introduced, whereas the latter two methods add an additional  $0.5T_s$  delay, which consequently leads to a critical frequency  $\omega_c = \omega_s/8$ , corresponding to the  $2T_s$  delay.

Fig. 8 shows the Bode diagrams of  $T(z)$  for the R controller discretized with two different methods.  $T(z)$  is derived from Fig. 2(a), which is given by

$$\begin{aligned} T(z) &= R(z)z^{-1}Z_{zoh}[G_p(s)] \\ &= R(z)z^{-1} \frac{(1+z^{-1})[1-\cos(\omega_r T_s)]}{1-2z^{-1}\cos(\omega_r T_s)+z^{-2}} \end{aligned} \quad (20)$$

where the ZOH transformation is applied to  $G_p(s)$  at  $f_s = 10$  kHz,  $R_{r-p}(z)$  and  $R_{f-b}(z)$  are considered for the R controller,  $R(z)$ . It is seen that the unstable case in Fig. 6(b) is stabilized when the R controller is discretized with the two-integrator-based method. This explains why the voltage loop is stable in [11] even though  $\omega_r$  is below  $\omega_s/6$  therein.

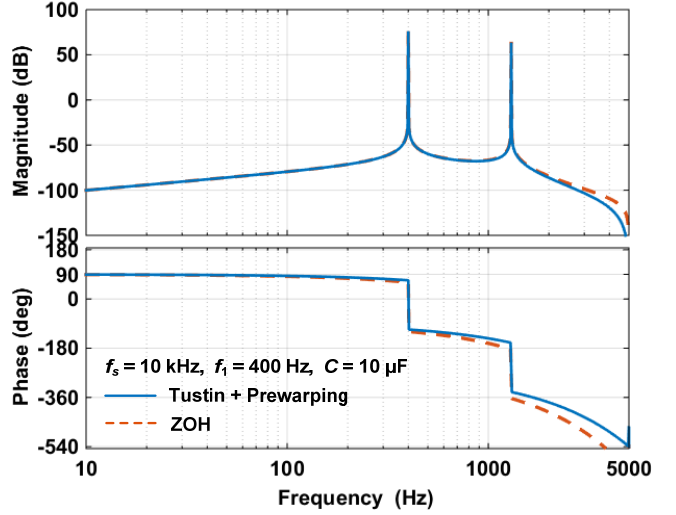

Fig. 8. Bode diagrams of  $T(z)$  with two different discretized R controller  $R(z)$ .

### III. PROPOSED CONTROL APPROACH

In this section, a single-loop voltage control approach with the widened stability region is proposed, and a holistic design of controller parameters based on the  $z$ -domain root contours is presented.

#### A. Operation Principle

Fig. 9 illustrates the block diagram of the proposed control scheme, which is composed by the voltage controller  $G_v(s)$  for the output voltage regulation and a damping controller  $G_d(s)$  for active stabilization when the filter resonance frequency  $\omega_r$  is below the critical frequency  $\omega_s/6$ . For the voltage controller  $G_v(s)$ , instead of using the R controller, the basic I controller is inserted in the forward path for obtaining the phase lag of  $\pi/2$ . The conventional PR controller can then be adopted, where the R controller gain is merely designed for zero steady-state error, yet with little phase effect at the phase crossover frequency,  $\omega_p$ , which is given by [18], [19]

$$\frac{k_{ic}}{\omega_p} \approx \frac{k_p}{20} \quad (21)$$

where  $k_{ic}$  is the gain of the R controller used with the proposed scheme. In contrast, the P controller is designed for the system stability, whose value is not affected by  $\omega_1$  as that using the R controller only in (14).

Fig. 10 shows the Bode diagrams for  $T(s)$  with the basic I controller ( $1/s$ ) only at  $f_s = 10$  kHz. The same stability characteristics as that using the R controller in Fig. 6(b) can be observed. However, it is noted that the phase response in Fig. 9 starts from  $-\pi/2$ , rather than  $\pi/2$  as shown in Fig. 6(b). This implies the phase compensation is needed for the R controller and, particularly when the fundamental frequency is increased. The R controller with the phase compensation is given by

$$R_c(s) = \frac{s \cos(\theta_c) - \omega_1 \sin(\theta_c)}{s^2 + \omega_1^2} \quad (22)$$



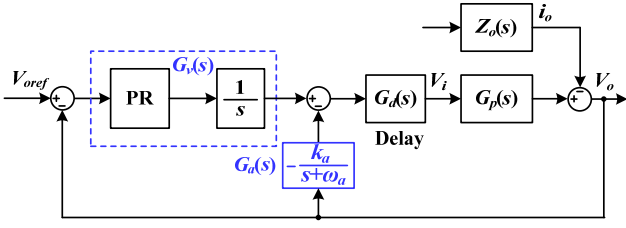

Fig. 9. Block diagram of the proposed single-loop voltage control scheme.

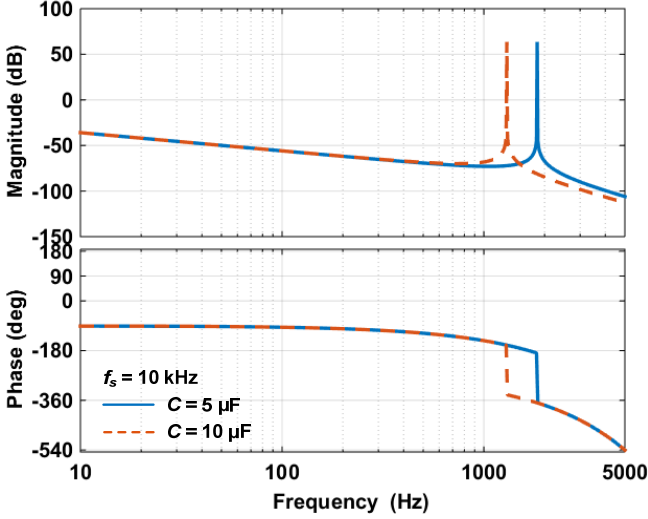

Fig. 10. Bode diagrams of  $T(s)$  with the unity-gain I controller, i.e.  $1/s$ .

where  $\theta_c$  is the phase lead, which can be derived as [17]

$$\theta_c = \frac{\pi}{2} + 1.5\omega_1 T_s \quad (23)$$

Fig. 11 plots the Bode diagrams of the discretized I controller with different methods. Similar to Fig. 7, the Tustin method has no additional phase lag, which leads to  $\omega_c = \omega_s/6$ . Yet, the forward Euler causes  $0.5T_s$  delay, which shifts  $\omega_c$  to  $\omega_s/8$  ( $2T_s$  delay), yet the backward Euler reduces  $0.5T_s$  delay, and thus  $\omega_c$  is increased to  $\omega_s/4$  ( $T_s$  delay).

To further widen the stability region, a damping controller  $G_d(s)$  (see Fig. 9) is equipped with the voltage feedback loop, which is based on a negated first-order low-pass filter, as given below

$$G_d(s) = \frac{-k_a}{s + \omega_a} \quad (24)$$

The closed-loop response of the voltage loop including  $G_v(s)$  and  $G_d(s)$  can then be derived as

$$V_o = \frac{G_v(s)G_d(s)G_p(s)}{1 + [G_v(s) + G_d(s)]G_d(s)G_p(s)} V_{oref} - \frac{Z_o(s)}{1 + [G_v(s) + G_d(s)]G_d(s)G_p(s)} i_o \quad (25)$$

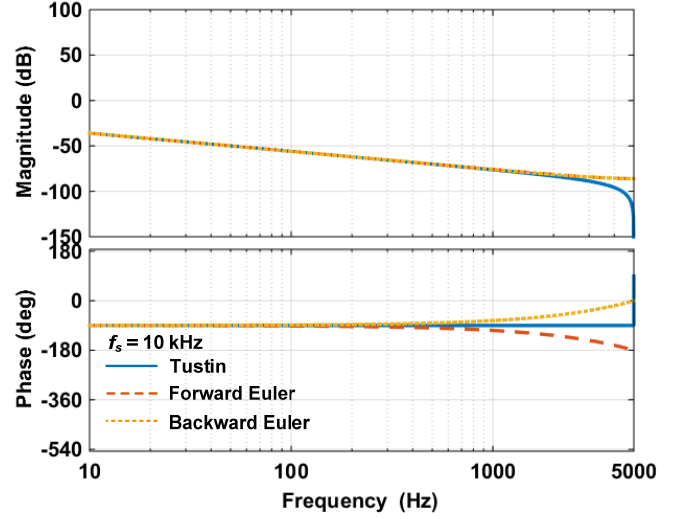

Fig. 11. Frequency responses of the different discretized I controllers.

where the open-loop gain with  $G_a(s)$  is changed as

$$T_a(s) = [G_v(s) + G_d(s)]G_d(s)G_p(s) \quad (26)$$

As  $G_v(s)$  can be simplified to  $k_p/s$  for the stability analysis,  $T_a(s)$  can be equivalent as (27) showing that  $G_d(s)$  and  $G_v(s)$  essentially synthesize a lead-lag filter in cascade with the I controller.

$$T_a(s) = \left[ \frac{k_p}{s} - \frac{k_a}{s + \omega_a} \right] G_d(s)G_p(s) = \frac{(k_p - k_a)s + k_p\omega_a}{s + \omega_a} \frac{1}{s} G_d(s)G_p(s) \quad (27)$$

It is worth noting that  $G_d(s)$  can also be used with the single-loop R control, where the R controller in (12) is approximated as  $k_r/s$ , which, together with the damping controller  $G_d(s)$ , also forms a lead-lag filter together.

To see the stabilization effect of  $G_d(s)$ , the phase of the lead-lag filter can be derived as

$$\angle \left\{ (k_p - k_a) \frac{j\omega + \frac{\omega_a}{1 - k_a/k_p}}{j\omega + \omega_a} \right\} = \begin{cases} [-\frac{\pi}{2}, 0], & k_a < k_p \\ [-\frac{\pi}{2}, 0], & k_a = k_p \\ [-\pi, 0], & k_a > k_p \end{cases} \quad (28)$$

It is seen that this lead-lag filter adds an additional phase lag and therefore widens the stability region of the voltage loop. The case of  $k_a > k_p$  leads to a wider range of phase lag than the other cases, yet it also adds a right half-plane zero into the open-loop gain, leading to the non-minimum phase response of the system.

### B. Co-Design of Active Damping and Voltage Controller

From (24) to (27), it is noted that three controller parameters mainly affect the system stability:  $k_a$ ,  $\omega_a$ , and  $k_p$ . A co-design procedure for these parameters is thus formulated below based on the root contours in the discrete  $z$ -domain. For discretization, the Tustin transformation is applied to  $G_a(s)$  and the I controller, which are given by

$$G_a(z) = -\frac{k_a}{\frac{2}{T_s} \frac{1-z^{-1}}{1+z^{-1}} + \omega_a}, \quad \frac{1}{s} = \frac{T_s}{2} \frac{1+z^{-1}}{1-z^{-1}} \quad (29)$$

such that no additional time delay is added by the discretized I controller. The discretized form of the open-loop gain with the damping controller  $G_a(z)$  can then be expressed as

$$T_a(z) = \left[ \frac{k_p T_s (1+z^{-1})}{2(1-z^{-1})} - \frac{k_a T_s (1+z^{-1})}{2(1-z^{-1}) + \omega_a T_s (1+z^{-1})} \right] \cdot z^{-1} \cdot \frac{(1+z^{-1})[1-\cos(\omega_r T_s)]}{1-2z^{-1}\cos(\omega_r T_s) + z^{-2}} \quad (30)$$

The sampling frequency is  $f_s = 10$  kHz, since in this case  $C = 10$   $\mu\text{F}$  leads to  $\omega_r < \omega_s/6$ , which necessitates the use of  $G_a(s)$ .

The overall objective of the co-design is to shift the root loci to equate the natural frequencies of the conjugate pole pairs [9], [20].

- 1) The root locus of  $T(z)$  without  $G_a(z)$  is plotted first to see the effect of varying  $k_p$  on the closed-loop poles of the system.
- 2) A few typical  $k_p$  values are then chosen based on step 1), and the root contours of  $T_a(z)$  with the changes of  $k_a$  and  $\omega_a$  are plotted. Each root locus depicts the movement of closed-loop poles with the increase of  $k_a$  for a given  $k_p$ . A sweep of  $\omega_a$  from  $0.1\omega_s$  to  $0.5\omega_s$  at the step of  $0.1\omega_s$  is performed to identify the range of controller parameters.
- 3) Finally, the parameters are chosen by sweeping  $\omega_a$  at a smaller step and slightly tuning the  $k_p$  value.

For illustration, Fig. 12 plots the root contours for the case of  $C = 10$   $\mu\text{F}$ . First, the root locus for  $T(z)$  (dashed line) is plotted, which clearly shows that the system is unstable without  $G_a(z)$ . This agrees with the stability region predicted in Fig. 10. Then, three values of  $k_p$  are chosen for plotting the root contours (solid lines) with a sweep of  $\omega_a$ . Each root locus (solid line) indicates the movement of poles along with the increase of  $k_a$ . It can be seen that two conjugate pole pairs will appear if the controller parameters are not properly chosen. Their natural frequencies affect the system response [9]. Moreover, simply increasing the cutoff frequency  $\omega_a$  can hardly equate the conjugate pole pairs. Hence, the tuning of  $k_p$  is needed. By taking a closer look at Fig. 12(c), it can be found that the possible range of  $\omega_a$  is  $0.2\omega_s < \omega_a < 0.3\omega_s$ . With a sweep at a smaller step,  $0.02\omega_s$  for example, the controller parameters for the single conjugate pole pair can be found, which is shown in Fig. 13.

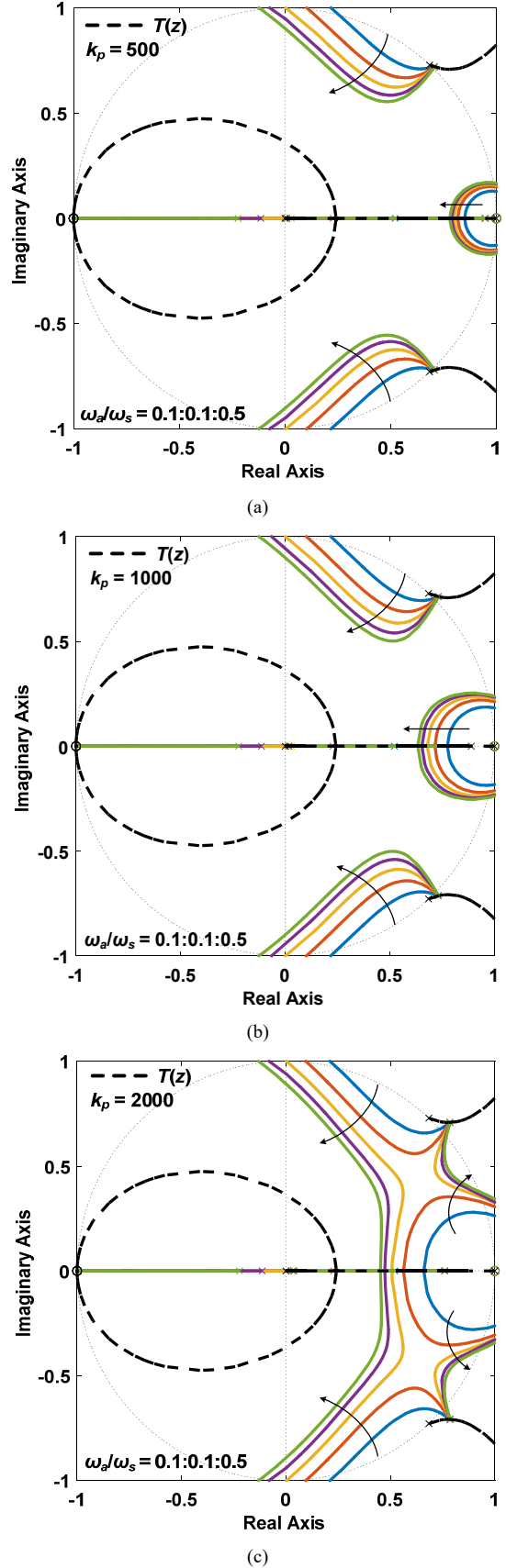

Fig. 12. Root contours for designing the proposed controller parameters with  $C = 10$   $\mu\text{F}$ ,  $f_s = 10$  kHz. (a)  $k_p = 500$ . (b)  $k_p = 1000$ . (c)  $k_p = 2000$ .



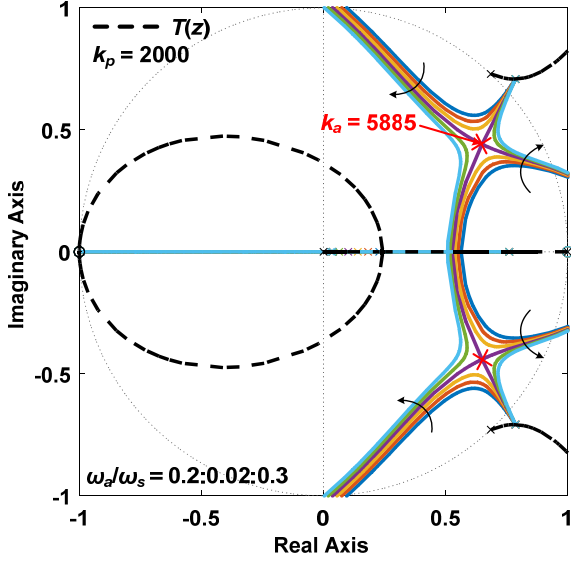

Fig. 13. Root contours for identifying the proposed controller parameters ( $k_p = 2000$ ,  $k_a = 5885$ ,  $\omega_a = 0.26\omega_s$ ) with  $C = 10 \mu\text{F}$ ,  $f_s = 10 \text{ kHz}$ .

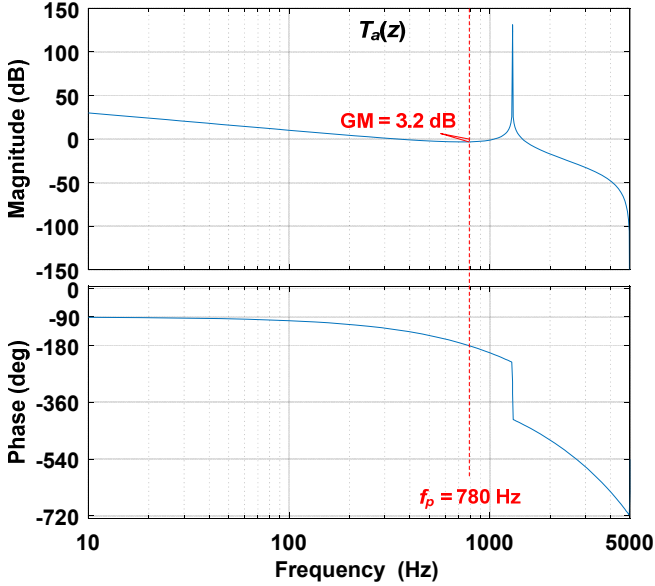

Fig. 14. Frequency response of the open-loop gain  $T_a(z)$  with the controller parameters identified in Fig. 13.

TABLE II  
CONTROLLER PARAMETERS

Symbol	Controller Parameter	Value
$k_i$	Gain for using the R controller only	200
$k_p$	P controller gain of PR-I controller	2000
$k_{ic}$	R controller gain of PR-I controller	490000
$k_a$	Gain of damping controller $G_d(s)$	5885
$\omega_a$	Cut-off frequency of controller $G_d(s)$	$0.26\omega_s$

Fig. 14 then shows the frequency response of the open-loop gain of the proposed control scheme,  $T_{ad}(z)$ , which is based on the controller parameters identified in Fig. 13. It is seen that the phase crossover frequency is reduced to 780 Hz, which implies that the control loop is kept stable, since the LC-filter resonance

frequency is above that frequency. A positive GM (3.12 dB) at the phase crossover frequency can also be observed. The R controller gain,  $k_{ic}$ , can be identified according to (19). Table II summarizes the co-designed controller parameters.

#### IV. SIMULATION AND EXPERIMENTAL RESULTS

For validating theoretical analysis, time-domain simulations using the MATLAB/Simulink and PLECS Blockset are carried out, and the experiments tests for a 400-Hz three-phase, three-wire VSI system with the 10 kHz sampling frequency are also performed. The main circuit and controller parameters provided in Table I and Table II are used in simulations and experiments. All voltage waveforms shown below are line-to-line voltages and current waveforms are phase currents. LC-filter parameters,  $C = 10 \mu\text{F}$ ,  $L = 1.5 \text{ mH}$ , result in  $\omega_s/8 < \omega_r < \omega_s/6$ , which enables to see the effects of the discretization methods used with the R controller in the single-loop R voltage control scheme.

##### A. Simulation Results

First, the single-loop R voltage control scheme is evaluated at the zero load condition, which is the worst case with no damping provided by the load. The simulated capacitor-voltage waveform is shown in Fig. 15, where the discretization method applied to the R controller is changed, from the two-integrator-based method to the Tustin transformation with prewarping, at the time instant of 0.4 s. It is clear that the system is destabilized after 0.4s, which confirms the stabilizing effect of the additional time delay ( $0.5T_s$ ) with the two-integrator-based discretization method. In this case, the R controller gain (see Table II) is designed based on the frequency response of  $T(z)$  with the two-integrator-based R, which has been shown in Fig. 8. No phase compensation as in the case of the R controller in (22) is needed.

Fig. 16 then shows the simulated capacitor voltage and load current with the proposed control scheme. Both the I controller of  $G_v(s)$  and  $G_d(s)$  are discretized by the Tustin transformation, which implies that no additional time delay ( $0.5T_s$ ) is added into the system. The R controller of  $G_v(s)$ , which is given by (22), is discretized with the Tustin transformation with prewarping at the fundamental frequency. The controller parameters, which are co-designed based on Figs. 12-15, are evaluated with a step change of a resistive load ( $254 \Omega$ ). A stable operation with a good dynamic response is observed. The stable operation under

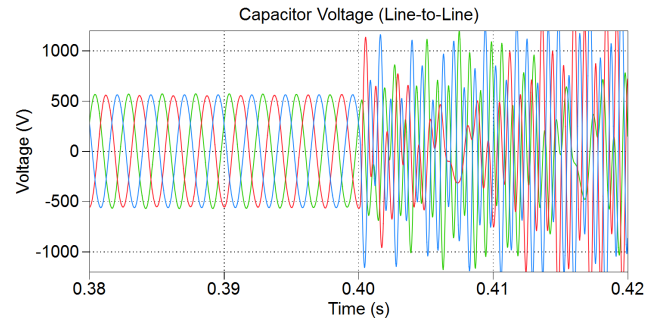

Fig. 15. Simulated ac capacitor (line-to-line) voltage for the single-loop R control scheme at the zero load condition, where the discretization method for the R controller is changed from the two-integrator-based scheme to the Tustin transform with prewarping at the time instant of 0.4 s.

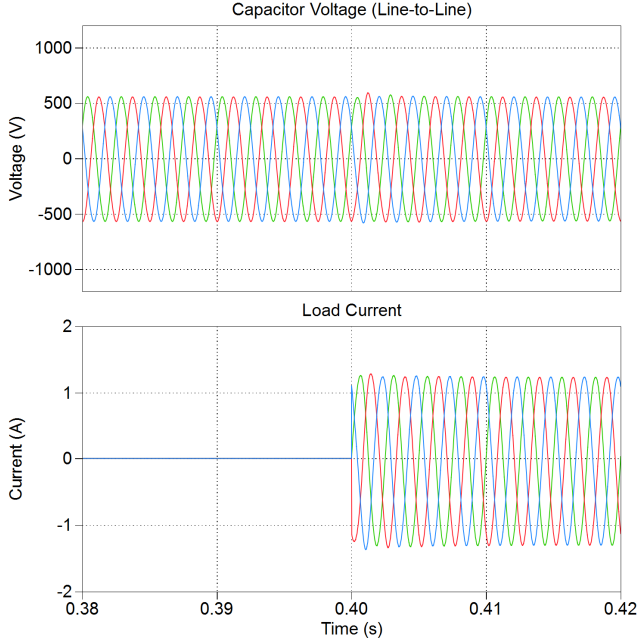

Fig. 16. Simulated ac capacitor (line-to-line) voltage and load current for the proposed control scheme, where a step response of a resistive load ( $254 \Omega$ ) is tested at the time instant of 0.4 s.

the zero load condition also confirms that the proposed control scheme exhibits a widened stability region even without adding additional time delay by the discretization of the I controller.

Subsequently, Fig. 17 shows the simulation results for the proposed control scheme with a parallel R/C load. Since the switching current ripples flow through the load capacitance, only the current flowing through the resistance is provided. In this case, the P controller gain of  $G_v(z)$  is reduced from 2000 to

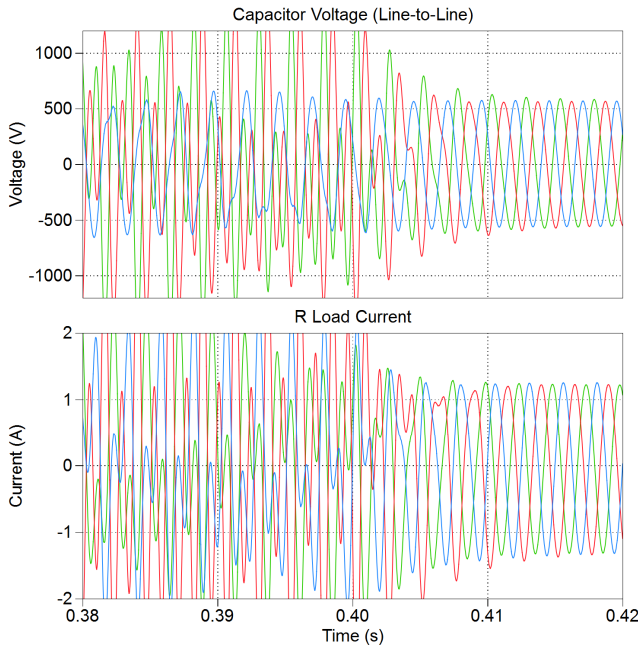

Fig. 17. Simulated ac capacitor (line-to-line) voltage and the R-load current for the proposed control scheme with the parallel R/C load, where the P controller gain is reduced from 2000 to 1500 at the time instant of 0.4 s.

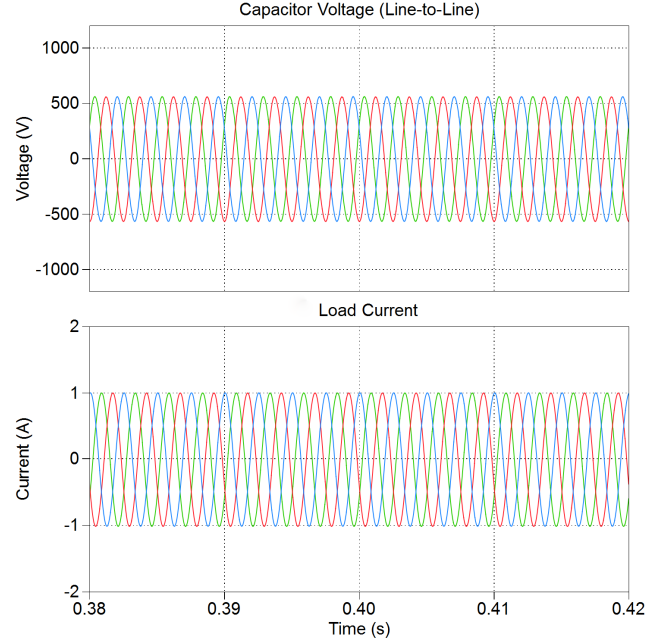

Fig. 18. Simulated ac capacitor (line-to-line) voltage and the R-load current for the proposed control scheme with the series R-L load.

1500 at the time instant of 0.4 s. It is clear that the presence of load capacitance destabilizes the control system, and a reduced P controller gain is needed to preserve stability. This is due to the fact that the load capacitance shifts the resonance frequency to a lower value, which tends to cause a negative GM of the open-loop gain. In contrast, the series R-L load is tested in Fig. 18, where a stable response can be observed.

Fig. 19 further shows the simulation results considering the LC-filter parameter variations, where the zero load condition is simulated. The filter capacitance is reduced to  $9 \mu\text{F}$  for three phases, while the filter inductances of the phase-A and phase-C are increased to 1.8 mH and of the phase-B is increased to 2.3 mH. The stable response of the capacitor voltage demonstrates the effectiveness of the proposed control scheme even under the variations of system parameters.

## B. Experimental Results

In the experiments, the single-loop voltage control schemes are implemented in the DS1007 dSPACE system, which integrates the DS2004 high-speed (800 ns) 16-bit A/D sampling board and the DS5101 digital waveform output board for the generation of switching pulses. The single-update mode of the PWM generation is adopted, which causes one switching period delay and half sampling period delay of the digital PWM. A constant-voltage (730 V) dc power supply is used to power the dc-link of the VSI. Due to the limited number of (four) channels of the oscilloscope, two line-to-line voltages ( $V_{AB}$  and  $V_{BC}$ ) and two phase currents ( $i_A$  and  $i_B$ ) are shown in the measured results.

To verify the simulation case studies, Fig. 20 shows the measured ac voltage waveform with the single-loop R control scheme at the zero load condition. The discretization for the R controller is changed from the two-integrator-based method to the Tustin transformation with prewarping at the fundamental frequency. The unstable response matches with the simulation

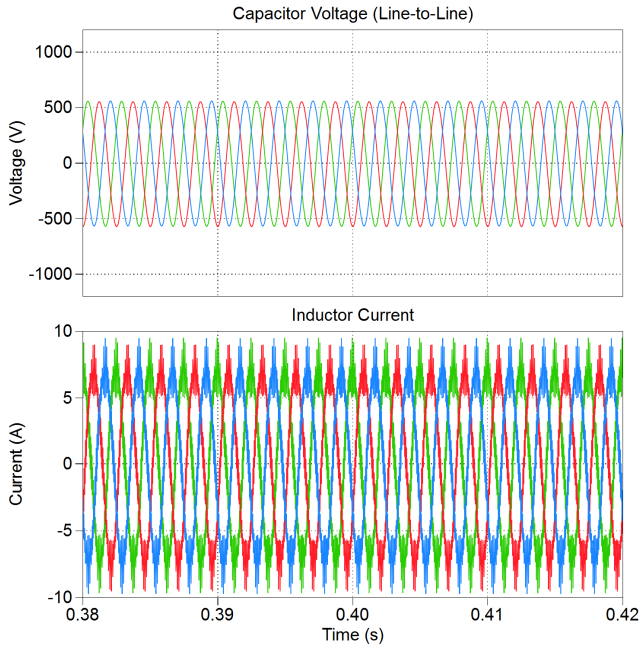

Fig. 19. Simulated ac capacitor (line-to-line) voltage and the filter inductor current for the proposed control scheme under the variation of the LC-filter parameters.

result in Fig. 15. Fig. 21 then shows the measured voltages and currents for the proposed control scheme with a step change of a resistive load (254  $\Omega$ ). It agrees with the simulation study in Fig. 16 and further confirms the stabilizing performance of the control approach.

Fig. 22 provides the measured results for the proposed control scheme with a paralleled R/C load. The current flows through the R load is shown. Similar to the simulation result shown in Fig. 17, the system is destabilized by the capacitive load, and it subsequently turns into stable operation when the P controller is reduced to  $k_p = 1500$ .

Fig. 23 shows the measured voltage and current waveforms with the series R-L load, where a stable response is observed. The measured results under the same variations of the LC-filter

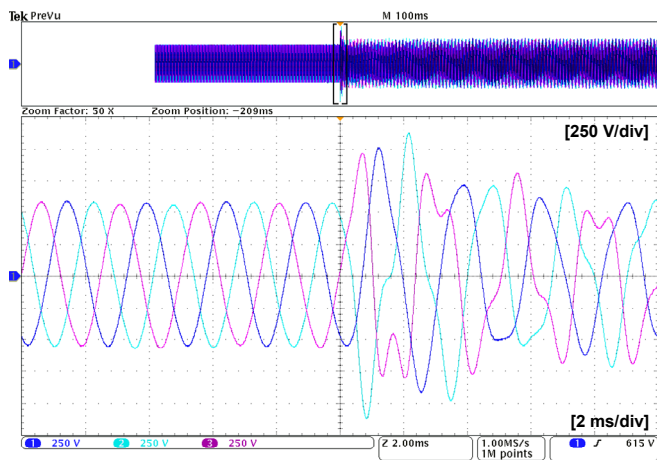

Fig. 20. Measured ac capacitor (line-to-line) voltage for the single-loop R control scheme at the zero load condition, where the discretization of R controller is changed from the two-integrator-based method to Tustin with prewarping method.

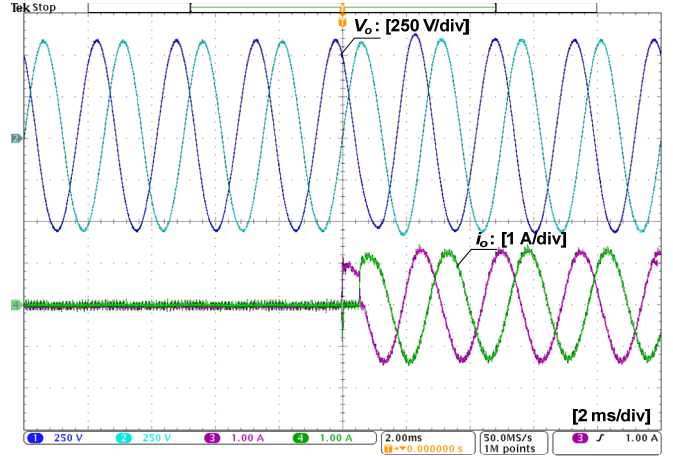

Fig. 21. Measured ac capacitor (line-to-line) voltage and load current for the proposed control scheme with a step response of a resistive load (254  $\Omega$ ).

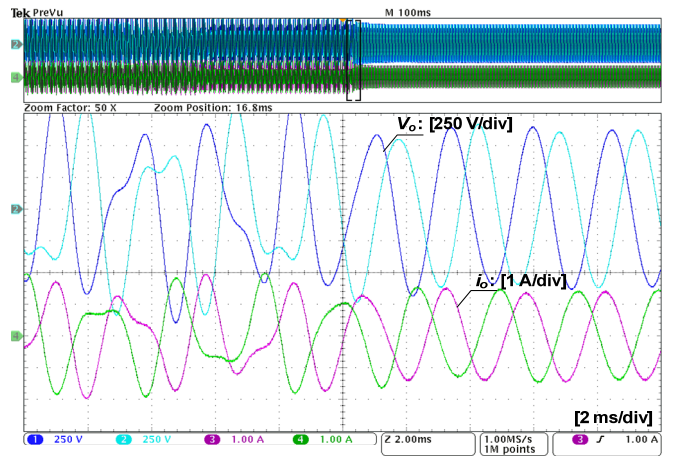

Fig. 22. Measured ac capacitor (line-to-line) voltage and the R-load current for the proposed control scheme with the parallel R/C load, where the P controller gain,  $k_p$  is reduced from 2000 to 1500 for system stabilization.

parameters as the simulation study are given in Fig. 24. A close correlation with the simulation results shown in Figs. 18 and 19 can be observed in both cases. Hence, the test results verify the effectiveness of the proposed control approach.

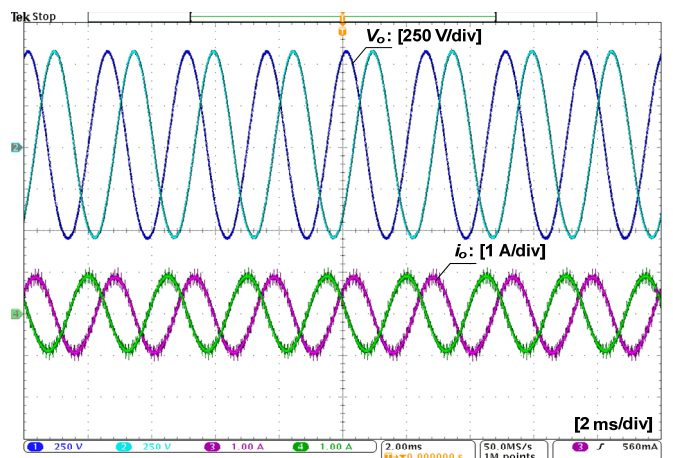

Fig. 23. Measured ac capacitor (line-to-line) voltage and load current for the proposed control scheme with the series R-L load.



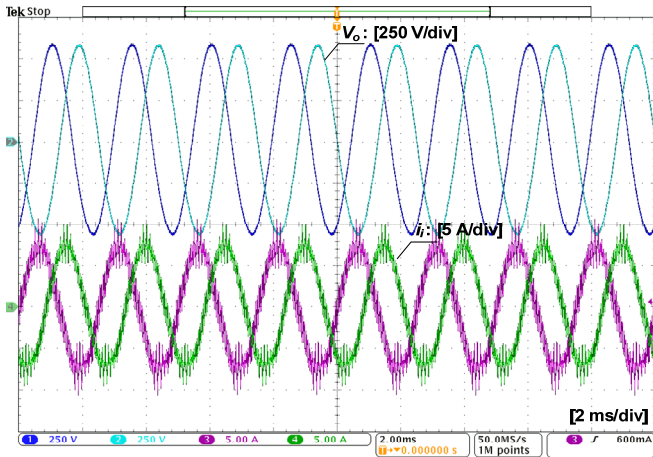

Fig. 24. Measured ac capacitor (line-to-line) voltage and the filter inductor current for the proposed control scheme under the variation of filter parameters ( $C = 9 \mu\text{F}$ ).

## V. CONCLUSIONS

This paper has discussed the stability of digital single-loop voltage control schemes for LC-filtered VSIs. The influences of the discretized R or I controllers on the system stability have been systematically identified with frequency-domain analysis, time-domain simulations, and experimental tests. It has been shown that the phase lag of the R or I controller can stabilize the control loop with a second-order LC-filter plant. A voltage feedback damping scheme has also been discussed with the root contours analysis in the discrete z-domain, and its stabilizing performance has been verified in simulations and experiments.

## REFERENCES

- [1] M. J. Ryan, W. E. Brumsickle, and R. D. Lorenz, "Control topology options for single-phase UPS inverters," *IEEE Trans. Ind. Appl.*, vol. 33, no. 2, pp. 493–501, Mar./Apr. 1997.
- [2] L. Mihalache, "DSP control of 400 Hz inverters for aircraft applications," in *Proc. IEEE IAS'02*, 2002, pp. 1564–1571.
- [3] X. Wang, F. Blaabjerg, and Z. Chen, "Autonomous control of inverter-interfaced distributed generation units for harmonic current filtering and resonance damping in an islanded microgrid," *IEEE Trans. Ind. Appl.*, vol. 50, no. 1, pp. 452–461, Jan./Feb. 2014.
- [4] N. R. Averous, M. Stieneker, and R. W. De Doncker, "Grid emulator requirements for a multi-megawatt wind turbine test-bench," in *Proc. IEEE PEDS 2015*, 2015, pp. 419–426.
- [5] M. Steurer, C. S. Edrington, M. Sloderbeck, W. Ren, and J. Langston, "A megawatt-scale power hardware-in-the-loop simulation setup for motor drives," *IEEE Trans. Ind. Electron.*, vol. 57, no. 4, pp. 1254–1260, Apr. 2010.
- [6] P. C. Loh and D. G. Holmes, "Analysis of multiloop control strategies for LC/CL/LCL-filtered voltage-source and current-source inverters," *IEEE Trans. Ind. Appl.*, vol. 41, no. 2, pp. 644–654, Mar./Apr. 2005.
- [7] X. Wang, Y. W. Li, F. Blaabjerg, and P. C. Loh, "Virtual-impedance-based control for voltage-source and current-source converters," *IEEE Trans. Power Electron.*, vol. 30, no. 12, pp. 7019–7037, Dec. 2015.
- [8] X. Wang, F. Blaabjerg, Z. Chen, and W. Wu, "Resonance analysis in parallel voltage-controlled distributed generation inverters," in *Proc. IEEE APEC 2013*, 2013, pp. 2977–2983.
- [9] R. Turner, S. Walton, and R. Duke, "Robust high-performance inverter control using discrete direct-design pole placement," *IEEE Trans. Ind. Electron.*, vol. 58, no. 1, pp. 348–357, Jan. 2011.
- [10] U. B. Jensen, F. Blaabjerg, and J. K. Pedersen, "A new control method for 400-Hz ground power units for airplanes," *IEEE Trans. Ind. Appl.*, vol. 36, no. 1, pp. 180–187, Jan./Feb. 2000.

- [11] Z. Li, Y. Li, P. Wang, H. Zhu, C. Liu, and F. Gao, "Single-loop digital control of high-power 400-Hz ground power unit for airplanes," *IEEE Trans. Ind. Electron.*, vol. 57, no. 2, pp. 532–543, Feb. 2010.
- [12] Y. Y. Tzou, "DSP-based fully digital control of a PWM dc-as converter for ac voltage regulation," in *Proc. IEEE PESC 1995*, 1995, pp. 138–144.
- [13] S. Hiti, D. Boroyevich, and C. Cuadros, "Small-signal modeling and control of three-phase PWM converters," in *Proc. IEEE IAS 1994*, 1994, pp. 1143–1150.
- [14] D. M. Van de Sype, K. D. Gusseme, A. P. Van den Bossche, and J. A. Melkebeek, "Small-signal laplace-domain analysis of uniformly-sampled pulse-width modulators," in *Proc. IEEE PESC 2004*, 2004, pp. 4292–4298.
- [15] S. Buso and P. Mattavelli, *Digital Control in Power Electronics*, San Francisco, CA: Morgan & Claypool Publ., 2006.
- [16] R. D. Middlebrook, "Predicting modulator phase lag in PWM converter feedback loops," in *Proc. Powercon 1981*, pp. H4.1–H4.6.
- [17] A. Yepes, F. Freijedo, J. Gandoy, O. Lopez, J. Malvar, and P. Comesana, "Effects of discretization methods on the performance of resonant controllers," *IEEE Trans. Power Electron.*, vol. 25, no. 7, pp. 1692–1712, Jul. 2010.
- [18] X. Wang, F. Blaabjerg, and P. C. Loh, "Virtual RC damping of LCL-filtered voltage source converters with extended selective harmonic compensation," *IEEE Trans. Power Electron.*, vol. 30, no. 9, pp. 4726–4737, Sept. 2015.
- [19] D. G. Holmes, T. A. Lipo, B. P. McGrath, and W. Y. Kong, "Optimized design of stationary frame three phase ac current regulators," *IEEE Trans. Power Electron.*, vol. 24, no. 11, pp. 2417–2426, Nov. 2009.
- [20] X. Wang, F. Blaabjerg, and P. C. Loh, "High-performance feedback-type active damping of LCL-filtered voltage source converters," in *Proc. IEEE ECCE 2015*, 2015, pp. 2629–2636.