

From DEPARTMENT OF MEDICINE, SOLNA
Karolinska Institute, Stockholm, Sweden

REGULATION OF MAST CELL FUNCTION AND SURVIVAL IN HEALTH AND DISEASE

Katarina Lyberg



**Karolinska
Institutet**

Stockholm 2016

All previously published papers were reproduced with permission from the publisher.

Published by Karolinska Institutet.

Printed by **Printed by E-Print AB 2016**

© Katarina Lyberg, 2016

ISBN 978-91-7676-505-0

Regulation of mast cell function and survival in health
and disease
THESIS FOR DOCTORAL DEGREE (Ph.D.)

By

Katarina Lyberg

Principal Supervisor:

Professor Gunnar Nilsson
Karolinska Institutet
Department of Medicine, Solna

Co-supervisor(s):

Docent Johanna Ungerstedt
Karolinska Institutet
Department of Medicine, Huddinge

Dr. Christine Möller Westerberg
Karolinska Institutet
Department of Medicine, Solna

Opponent:

Professor Karin Hartmann
University Hospital, Luebec
Department of Dermatology

Examination Board:

Docent Madeleine Rådinger
University of Gothenburg
Department of internal medicine

Professor Ola Winqvist
Karolinska Institutet
Department of Medicine, Solna

Professor Petter Höglund
Karolinska Institutet
Department of Medicine, Huddinge

Dedicated to the patients suffering from Mastocytosis

ABSTRACT

Mast cells are sentinels of danger but they are also the major effector cells in allergic disease causing the well-known allergic symptoms caused by their mediators such as histamine and prostaglandin D₂ that are released upon activation. Mastocytosis is a disease characterized by the clonal expansion of mast cells in the skin and/or other organs where the patients suffer from mediator-related symptoms and/or organ failure due to mast cell infiltration. The aim of the work presented in this thesis was to investigate mast cell function in health and disease, particularly systemic mastocytosis.

In paper I, we investigate the *in vivo* reactivity of mast cells in patients with mastocytosis. We show that though the patients with systemic mastocytosis have increased levels of circulating mast cell mediators their mast cells in skin and lung are no more reactive than those in healthy controls.

Paper II. We analyze the reactivity of *in vitro* cultured mast cells from the patients investigated in paper I, and could show that systemic mastocytosis mast cells proliferate and develop normally though with increased expression of the high affinity IgE receptor. Mast cells from patients with systemic mastocytosis are more reactive to increased osmolarity by releasing more PGD₂. Investigating the genetic background of mastocytosis we discovered that they exhibit a specific miRNA profile.

In the search for new therapeutical possibilities for mastocytosis we investigated the combination of ABT-737, a BH3 mimetic, and Roscovitine in paper III. By targeting expression and function of pro-survival proteins we found that even in very low doses the drugs induce apoptosis in mast cells carrying the D816V KIT mutation.

Paper IV. Histone deacetylase inhibitors (HDACi) alter genetic expression. Here we show that SAHA, a class II HDACi induces mast cell apoptosis in cell lines and primary systemic mastocytosis patient cells, and that KIT is epigenetically silenced by SAHA in KIT D816V mutated cells.

We have previously shown that IgE-receptor cross linking induces mast cell degranulation and activation-induced cell survival. In paper V we further investigate the effects of the Bcl-2 family and found that Bfl-1 is vital for the cell to survive, reform and be ready to degranulate again. Patients with allergic disease or cutaneous inflammatory skin disease have increased expression of Bfl-1 in their skin mast cells suggesting that targeting Bfl-1 might be an option for treatment.

Paper VI. Further investigating the function of the A1/Bfl-1 gene, we found that knockdown of A1/Bfl-1 in mice protects the animals from passive cutaneous and systemic anaphylaxis. Additionally, connective tissue mast cells depend on A1/Bfl-1 for their development and survival.

LIST OF SCIENTIFIC PAPERS

- I. T Gülen, C Möller Westerberg, KATARINA LYBERG, M Ekoff, J Kolmert, J Bood, J Öhd, S-E Dahlén, G Nilsson*, B Dahlén*, **Analysis of in vivo mast cell reactivity in patients with mastocytosis**, *Manuscript*
- II. KATARINA LYBERG, T Gülen, M Ekoff, C Engblom, C Möller Westerberg, B Dahlén, G Nilsson, **Mast cells from patients with mastocytosis show altered miRNA profile and osmotic induced hyperreactivity**, *Manuscript*
- III. KATARINA LYBERG, Gunnar Nilsson, Christine Möller Westerberg, **ABT-737 and Roscovitine induces apoptosis in a synergistic fashion in mast cells carrying the D816V mutation**, *Integr Cancer Sci Therap* 2015 2(5): 267-271
- IV. KATARINA LYBERG, H Abdulkadir Ali, J Grootens, M Kjellander, M Tirfing, M Arock, H Hägglund, G Nilsson*, J Ungerstedt*, **Histone deacetylase inhibitor SAHA mediates mast cell death and epigenetic silencing of constitutively active D816V KIT in systemic mastocytosis**, *Manuscript*
- V. M. Ekoff, KATARINA LYBERG, M. Krajewska, M. Arvidsson, S. Rak, JC Reed, I. Harvima, G. Nilsson. **Anti-apoptotic Bfl-1 is the major effector in activation-induced human mast cell survival**. *Plos One* 2012, 7(6):e39117
- VI. E Ottina*, KATARINA LYBERG*, A Villunger[#], G Nilsson.[#] **Knockdown of the anti-apoptotic Bcl-2-family member A1/Bfl-1 protects mice from systemic anaphylaxis**. *Journal of Immunology*, 2015, 194:1316-1322

CONTENTS

1.	Introduction.....	1
1.1	The mast cell.....	1
1.1.1	Mast cells in health and disease.....	1
1.1.2	Development.....	2
1.1.3	The KIT receptor and downstream signaling pathways.....	3
1.1.4	Mast cell mediator release.....	5
1.1.5	FcεRI activation.....	5
1.1.6	Mast cell mediators.....	5
1.2	Mastocytosis.....	7
1.2.1	Introduction.....	7
1.2.2	Genetics.....	7
1.2.3	Symptoms.....	9
1.2.4	Diagnosis.....	10
1.2.5	Forms of mastocytosis and disease progression.....	10
1.2.6	Treatment.....	12
1.2.7	Drugs in research.....	12
1.3	regulation of Mast CELL survival and Apoptosis.....	15
1.3.1	Introduction.....	15
1.3.2	The Bcl-2 family.....	15
1.3.3	Activation induced survival.....	16
1.4	Epigenetics.....	18
1.4.1	Introduction.....	18
1.4.2	DNA structure.....	18
1.4.3	DNA modifications.....	18
1.4.4	Histone modifications.....	18
1.4.5	Micro RNA.....	19
2	The present study.....	21
2.1	Aim.....	21
2.2	Material and Methods.....	22
2.3	Paper I; Analysis of in vivo mast cell reactivity in patients with SYSTEMIC mastocytosis.....	26
2.4	Paper II; Mast cells from patients with mastocytosis show altered miRNA profile and osmotic induced hyperreactivity.....	28
2.5	Paper III; ABT-737 and Roscovitine induces apoptosis in a synergistic fashion in mast cells carrying the D816V mutation.....	31
2.6	Paper IV; Histone deacetylase inhibitor SAHA mediates mast cell death and epigenetic silencing of constitutively active D816V KIT in systemic mastocytosis.....	33
2.7	Paper V; Anti-apoptotic Bfl-1 is the major effector in activation-induced human mast cell survival.....	36

2.8	Paper VI; Knockdown of the anti-apoptotic Bcl-2-family member A1 protects mice from systemic anaphylaxis	38
3	Future perspective	41
4	Acknowledgements.....	43
5	References	45

LIST OF ABBREVIATIONS

Ago2	Argonaute 2
AKT	AKT serine/threonine kinase 1
AML	Acute myeloid leukemia
ASM	Aggressive systemic mastocytosis
ASXL1	Additional sex combs like 1
ATP	Adenosine triphosphate
BAD	BCL2 associated agonist of cell death
BAX	BCL2 associated X
Bcl-w	BCL2 like 2
Bcl-xL	B-cell lymphoma-extra large
Bfl-1	BCL2 related protein A1
BH3	Bcl-2 homology domain 3
Bim	BCL2 like 11
Cbl	Cbl proto-oncogene
CCR	C-C motif chemokine receptor
CLL	Chronic lymphocytic leukemia
CM	Cutaneous mastocytosis
CML	Chronic myeloid leukemia
CRTH2	Prostaglandin D2 receptor 2
CXCR	C-X-C motif chemokine receptor
Dicer	Dicer 1, ribonuclease III
DNA	Deoxyribonucleic acid
Drosha	Drosha ribonuclease III
ERK	mitogen-activated protein kinase 1

FcεRI	High-affinity IgE receptor
FOXO	Forkhead box O
Fyn	FYN proto-oncogene, Src family tyrosine kinase
Grb2	Growth factor receptor bound protein 2
GSK3β	Glycogen synthase kinase 3 beta
IgE	Immunoglobulin E
IL	Interleukin
ISM	Indolent systemic mastocytosis
JAK	Janus kinase
KIT	KIT proto-oncogene receptor tyrosine kinase
Lyn	LYN proto-oncogene, Src family tyrosine kinase
MAPK	Mitogen-activated protein kinases
MC	Mast cell
MC-CPA	Mast cell Carboxypeptidase A
MCL	Mast cell leukemia
Mcl-1	BCL2 family apoptosis regulator
MCp	Mast cell progenitor
MDM2	Mouse double minute 2 homolog
MEK	Mitogen-activated protein kinase kinase
miRNA	Micro RNA
MMC	Mucosal mast cell
mTOR	Mechanistic target of rapamycin
NFAT	Nuclear factor of activated T-cells
NFκB	Nuclear factor kappa-light-chain-enhancer of activated B cells

PAR-2	Protease activated receptor 2
PDK	Phosphoinositide-dependent kinase
PGD2	Prostaglandin D2
PI3K	Phosphoinositide 3-kinase
PIAS	Protein inhibitor of activated STAT
PIP	Phosphatidylinositol 3,4,5-trisphosphate
PKC	Protein kinase C
PTEN	Phosphatase and tensin homolog
PTGDR	Prostaglandin D receptor
Raf	Raf-1 proto-oncogene, serine/threonine kinase
RISC	RNA-induced silencing complex
RNA	Ribonucleic acid
SCF	Stem cell factor
SH2	Src homology 2
SHIP1/2	Phosphatidylinositol-3,4,5-trisphosphate 5-phosphatase
SHP	Src homology region 2 domain containing phosphatase-1
Slug	Snail family transcriptional repressor
SM	Systemic mastocytosis
SM-AHN	Systemic mastocytosis with an associated hematologic neoplasm
SOCS	Suppressor of cytokine signaling
Sos	Son of sevenless
SRSF2	Serine and arginine rich splicing factor
STAT	Signal transducer and activator of transcription
TET2	Tet methylcytosine dioxygenase 2

TKI

Tyrosine kinase inhibitor

VCAM-1

Vascular cell adhesion molecule 1

1. INTRODUCTION

1.1 THE MAST CELL

Mast cells are watchmen of the body responding quickly to danger signals by releasing a cocktail of mediators in order to activate neighboring cells and to recruit and activate the proper combatants of the immune system. They are highly conserved in both function and morphology, found in all species of vertebrates and originated about 450 million years ago (1). Though mast cells are a very important part of the immune system they are notorious for their involvement in asthma and allergy. First described in the thesis of Paul Erlich in 1878 and since then mostly studied for their harmful effects we now know that they are also protective; truly the “Dr Jekyll and Mr Hyde” of the human body (2).

1.1.1 Mast cells in health and disease

Mast cells reside in all tissues but predominantly in tissues that form boundaries to the surrounding environment as for example skin, lung and intestines (3, 4). At this position mast cells easily sense when the body borders have been breached and can act accordingly. The human body is constantly under attack from pathogens that could be harmful for us if they were let to roam free, and the immune system has developed in order to defeat pathogens as well as monitoring the body for signs of disturbances in the overall homeostasis. The immune system is divided into two parts of equal importance. The innate immune system is the first line of defense consisting of both mechanical barriers like the skin and mucosa as well as immune cells like mast cells, basophils and phagocytes. They have no memory of their own but express a wide variety of sensors that can detect an extensive range of danger signals. They can attack and destroy the invasive pathogens but also attract cells of the adaptive immune system. These cells, B and T lymphocytes, will respond by antibody production or with cellular responses. Mast cells bridge the innate and adaptive immunity by responding to the invasive pathogens and recruiting leukocytes to the place of infestation (5, 6). For example mast cells have the capacity to recognize bacteria by a wide range of pattern recognition receptors (7, 8). They can respond by releasing chemokines which recruit neutrophils into the inflamed tissue (9, 10). Many studies have shown that mast cells are vital in fighting peritoneal infections that otherwise may end in sepsis (11, 12). Many other stimuli caused by for example cell injury or cell stress leads to the release of mast cell mediators (13, 14). The mast cell mediators can under these circumstances help with the healing of the damaged tissues (15). Other danger signals that activate mast cells are changes in the basic body homeostasis like temperature, pressure, pH or osmolarity (16). In spite of all their good sides mast cells are notorious for their fundamental role in asthma and allergy (17). Allergic diseases include rhinitis, allergic asthma, food allergy and atopic dermatitis. When antigens enter the body the patient quickly suffers from acute symptoms like itch, swelling and mucus production. Why a harmless protein/antigen can cause a Th2 driven immune response resulting in plasma cells producing IgE specific to the protein we do not know. But when the IgE is in circulation it will bind to the high-affinity IgE-receptors, FcεRI, on mast cells and

basophils. The next time the antigen enter the body the IgE sensitized cells will be activate and release mediators which will instead of fighting an infection cause both the acute symptoms and in the long-term lead to tissue remodeling and chronic inflammation.

1.1.2 Development

Mast cells originate from hematopoietic stem cells that emerge from the bone marrow and the early mast cell progenitors home into the tissue. (18) Mast cell homeostasis is carefully monitored since any increase in mast cell numbers is potentially harmful for the tissues. The mechanism of how mast cell migration is initiated and performed is not entirely understood. However $\alpha 4\beta 7$ integrins have been shown to play a central role in tissue homing in mice interacting with endothelial VCAM-1 (19). Chemokines and their receptors also play a pivotal role in MCp transfer, for example human cord blood MCps express CCR3, CCR5, CXCR2 and CXCR4 (20). Chemotaxis could also be influenced by how inflamed tissues attract MCps. Patients with allergic asthma have increased numbers of mast cells in the lungs that express chemokine receptors CCR1 and CCR4(21).

Once mast cell progenitors enter the tissue they mature under the influence of the microenvironment. The surrounding cells secrete cytokines important for the maturation. Fibroblasts, stromal cells, endothelial cells and keratinocytes all produce stem cell factor (SCF) which is essential for the growth and differentiation of mast cells (22-25). SCF binds to the KIT receptor on the mast cell inducing phosphorylation of tyrosine kinases leading to a cascade of phosphorylation of the downstream targets including PI3K, MAPK and JAK/STAT (26). Mast cells express receptors for numerous cytokines notably it is the typical Th2 cytokines IL-3, IL-5, IL-6, IL-9 that drive mast cell differentiation while Th1 cytokines are inhibitory (20, 27, 28). Since the differentiation is so dependent on the secretion of cytokines from the surrounding cells it is not hard to imagine the vast heterogeneity of the mast cells within the body and even within the same organ (29, 30). They may vary in size, granulation and granular content. Maturing mast cells are packed with secretory granules which slowly fill with a variety of mediators. Human mast cells are basically divided into two groups, those that store tryptase in their granules (MC_T) and mast cells containing both tryptase and chymase (MC_{TC}) (31, 32). MC_T s are found in submucosal tissues and in healthy lungs while the MC_{TC} subtype is dominantly found in skin (33). In Eosinophilic esophagitis mast cells expressing only tryptase and carboxypeptidase A contribute significantly to the disease, which show that there is greater heterogeneity in mast cells than the mere two groups (34). In the murine system mast cells are also divided into two groups; the mucosal and connective tissue mast cells (35, 36). Mucosal mast cells are found in the mucosal tissue in low numbers in healthy mice (37). During an infection thought there is a drastic increase in MMC numbers. MMCs in the gut mainly produce two types of β chymases, mouse mast cell protease 1 and 2 (38). Connective tissue mast cells however are predominantly found in the skin. They are long lived with very low turnover. They express two different chymases (mMCP-4 and 5) but also two tryptases (mMCP-6 and 7) as well as MC-CPA (39). This is a general division and in real life mast cells are highly heterogenic and the protease expression

varies due to the tissue and even tissue localization, e.g., tracheal mast cells of both subtypes produce six serine proteases as well as carboxypeptidase-A3 (40).

1.1.3 The KIT receptor and downstream signaling pathways

The human *KIT* gene is located on chromosome 4q11-12 and is expressed in two isoforms (41). The isoforms differ in the presence or absence of a specific amino acid sequence (GNNK) in the extracellular domain. The splice variants differ in biological activity where the GNNK⁻ gives rise to stronger receptor phosphorylation and internalization, and downstream MAPK phosphorylation (42). In normal mast cells the isoforms are coexpressed but in neoplastic mast cells the GNNK⁻ receptor is domineering (43). The combination of the KIT mutation D816V and the GNNK⁻ transcript increase the proliferation which can in turn influence the treatment response. The KIT gene is highly conserved over species barriers (44). It is a type III tyrosine kinase receptor consisting of an extracellular part containing five immunoglobulin-like motifs, a trans membrane segment and an intracellular section where the kinase domains and activation loop are situated (45). It is the kinase domains and activation loop that catalyze the relocation of a phosphate group from ATP to the substrate. One SCF dimer binds to two KIT monomers resulting in receptor homo-dimerization and auto-phosphorylation on tyrosine residues. Upon tyrosine phosphorylation the receptor is internalized. The binding of adaptor proteins Grb2 will not only transfer the activation signal but also recruit Cbl leading to ubiquitination and degradation of the receptor (46). SHP1 and 2 can inhibit the function of KIT by binding to the phosphorylated residues, thus blocking downstream signal transduction (47, 48). PKC inhibit the activity of the KIT receptor by the phosphorylation of the kinase region (49). Slug has been identified as a direct transcriptional repressor of KIT (50). Interestingly there is a high turnover of the KIT receptor even without ligand-receptor interaction (51). Activation of the KIT receptor will initiate many regulatory pathways.

The phosphoinositide 3'-kinase (PI3K) pathway starts with the translocation of PI3K to the plasma membrane where it docks to tyrosine residue 721 using the SH2 domain (52). This will activate PIP3 in the plasma membrane that will anchor Akt to be phosphorylated by PDK1/2 (53-55). Once activated Akt can phosphorylate a large number of substrates. It will directly activate mTOR which leads to G1 cell cycle progression and cell proliferation (56). Akt can also phosphorylate and activate MDM2, a negative regulator of tumor-suppressor gene p53. By similar indirect manner NFκB is activated. Activated Akt will inhibit apoptosis by disarming proapoptotic Bim in two steps; inhibition of transcription by inactivation of the Forkhead transcription factors FOXO1a and FOXO3a and by direct phosphorylation of Bim (57). Akt also inactivate pro-apoptotic proteins like Bad and Bax (58, 59). GSK3β is inactivated by AKT leading to the accumulation of cyclin D1 and cell proliferation. The PI3K pathway is negatively regulated by the PIP3 phosphatases SHIP1/2 and PTEN which will convert PIP3 to PIP2 (60, 61).

The Janus kinase 2 (JAK2) is constitutently associated to KIT and is promptly phosphorylated by SCF binding (62). STAT5 will dock to the phosphorylated tyrosine residue via their SH2

domain (63). JAK2 will then phosphorylate STAT5 allowing for them to dimerise. STAT dimers enter the nucleus where it will bind to specific gene promoters and direct transcription. Genes that are regulated by STAT5 include for example GATA2 and Bcl-X_L that drive cell proliferation, development and survival (64, 65). The JAK/STAT pathway is quickly activated but also short lived. Once the STAT dimers are formed they are targets of tyrosine phosphatases, as is phosphorylated JAK (66). SOCS3 inhibit the pathway by binding to the phosphorylated JAK marking it for degradation (67). PIAS proteins on the other hand will inhibit STAT5 action at the transcription site (68).

Using adaptor proteins binding to the SH2 domain, the RAS/MAPK pathway is activated (69). The adaptor protein Grb2 binds directly to tyrosine residues in the KIT receptor. It forms a complex with guanine exchange factor Sos, which in turn activates the membrane bound protein RAS (70). Activated RAS will in turn activate MAP3K Raf directing phosphorylation of MAPKK MEK and then MAPK ERK1/2 (71). Phosphorylated Erk 1/2 may translocate to the nucleus or stay in the cytoplasm depending on the substrates (72). In fact there are hundreds of substrates through which ERK have numerous ways to influence cellular proliferation and survival.

The Src tyrosine kinases Fyn and Lyn are yet another pathway in which KIT signaling is transferred (73). They express SH2 domains which interact with the phosphorylated tyrosine residues on the KIT receptor. Activated Src kinases will initiate PI3K, JAK/STAT and the RAS/MAPK pathways. They have shown to be important in mast cell proliferation and chemotaxis (74). Mast cells harboring the D816V mutation are largely independent of Src activation (75).

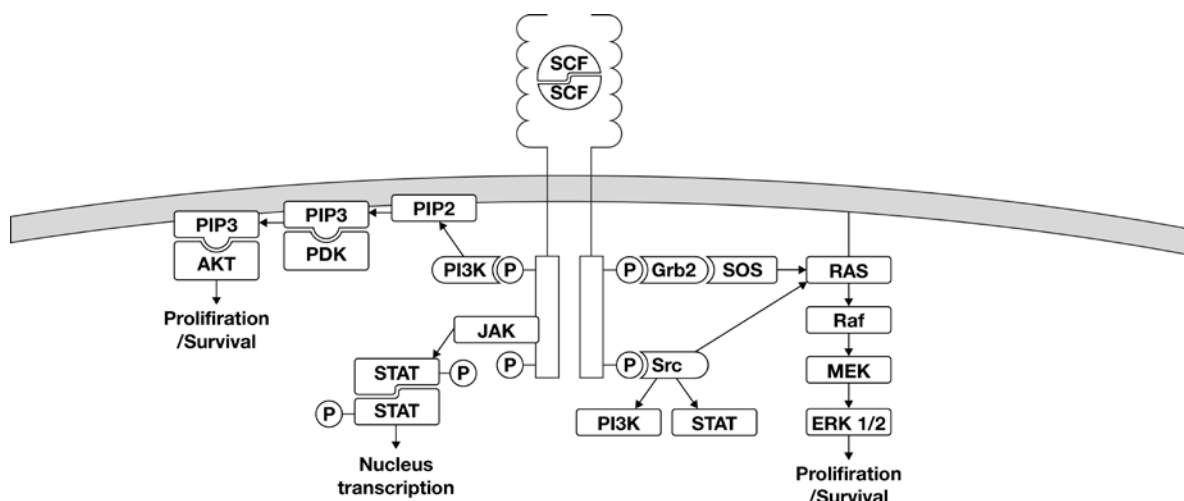

Figure 1, The activation pathways of the KIT receptor. SCF binding to the KIT receptor will activate a downstream cascade of phosphorylation, initiating transcription of survival and proliferation genes and inhibiting pro-apoptotic proteins.

1.1.4 Mast cell mediator release

Mast cells can be activated by a wide variety of stimuli and they may respond in many ways. Within seconds upon activation, e.g., through the high affinity IgE-receptor, mast cells can release the content of their preformed secretory granules. Receptor activation leads to cytoskeletal rearrangement and microtubule formation (76, 77). The granule slide along the tubule and when they reach the plasma membrane they fuse first with each other and then with the outer membrane to spill the content into the extracellular space (78, 79). Mast cells can also produce and secrete lipid mediators. Activation of Phospholipase A₂ initiates the release of arachidonic acid from the cell membrane (80). Via the cyclooxygenase pathway prostaglandins are produced. Mast cells predominantly produce prostaglandin D₂ (PGD₂) upon activation though they may also produce PGE₂ (81). The prostaglandins are transported out of the cells via the multidrug resistance protein 4 and possibly other transporter proteins (82). Through the lipoxygenase pathway arachidonic acid is converted into the lipoxygenase (LT) pathway generating LTB₄ and the cysteinyl leukotriens LTC₄, D₄ and E₄ (83). Mast cells can also produce cytokines and chemokines in response to stimulation. Thus, some cytokines and chemokines are stored in the secretory granules and subsequently released within seconds of degranulation (84, 85), while other cytokines are newly synthesized as a response to stimulation.

1.1.5 FcεRI activation

The most excessive studied pathway for mast cell activation is through the high affinity immunoglobulin E receptor FcεRI. The receptor is composed of four subunits, the extracellular, transmembrane bound α unit, the β unit which cross the membrane four times and the two γ units which are bound by a disulfide bond and mediates the intracellular signaling (86, 87). The extracellular part of the α-unit contains two binding domains for the heavy chain of the IgE molecule. When the cell-surface bound IgE recognize a multivalent antigen the receptors aggregate and become cross-linked. The receptor-IgE-antigen complex is internalized setting of the activation cascade resulting in cytoskeletal rearrangement, expulsion of granules and secretion of lipid mediators and cytokines (88). Once mast cells have been activated some of them have the unique capacity to survive and regranulate and thus be ready to be reactivated within a short space of time (89).

1.1.6 Mast cell mediators

Mast cells have the ability to produce and release numerous mediators depending on the stimulation (39). Histamine is formed from histidine by the enzyme L-histidine decarboxylase and is stored in the secretory granules (90). It is released upon activation like FcεRI crosslinking and bind to the histamine receptors H₁-H₄ on diverse cells and tissues (91). Histamine is a powerful mediator with many effects, e.g. regulating the sleep-wake rhythm, wound healing, vasodilation and smooth muscle contraction. Many of the symptoms displayed by mast cell associated diseases are a result from histamine release which is why antihistamines are widely used.

Mast cells produce and store large amounts of proteases which bind and cleave specific substrates (32). The proteases produced are non-mast cell specific (e.g. granzymes) and three classes of mast cell specific proteases; Trypsin, Chymase and Carboxypeptidase A. Trypsin is a neutral serine protease stored in the mast cell granule and released upon activation. There are two subgroups α I and II and β I-III. Catalytic active trypsin is stored within the mast cell granules and is able to cleave its substrates directly upon release, however mast cells also continuously secrete trypsin (92). Neuropeptides, prothrombin, fibrinogen are examples of proteins which carry a substrate sequence and are thus degraded by trypsin (93). Trypsin also have the ability to activate the PAR-2 receptor on various tissues. PAR-2 activation leads to bronchodilatation, vascular relaxation and altered gastrointestinal epithelial permeability (37, 94, 95). Humans express only one form of chymase and it is almost exclusively found in mast cells. In allergic disease chymase augment the effect of histamine on wheal formation but it can also degrade danger signals, e.g. IL-33, thus reducing inflammation (96-98). In healthy tissue chymase is involved in managing connective tissue homeostasis (99). Carboxypeptidase A is stored in mast cell granules in its active form though activation is kept low by the suboptimal pH (100). Biological substrates include endothelin-1, angiotensin I and sarafotoxin 6. It has been implicated to contribute in anaphylaxis and can be used as a diagnostic marker (101).

Prostaglandin D₂ is *de novo* synthesized by activated mast cells and can cause contraction of the airways, regulate body temperature and cause vasodilatation all depending on what tissue is activated via binding to the PTGDR (DP1) and CRTH2 (DP2) receptors. The PTGDR receptor is associated to asthma and specific groups of disease severity (102). CRTH2 is expressed on T cells, basophils and eosinophils among others (103). By activating the CRTH2 receptor PGD₂ will stimulate migration and the production of Th2 proinflammatory cytokines (104). CRTH2 is also expressed on the surface of type 2 innate lymphoid cells, these cells are enriched in the nasal polyps of patients suffering from rhinitis (105).

1.2 MASTOCYTOSIS

1.2.1 Introduction

Mastocytosis is a disease where mast cells accumulate in one or more tissues well beyond normal numbers and the cell infiltrate per se as well as the large amount of mediators that they release will cause a number of different symptoms (106, 107). The symptoms greatly depend on which tissues are affected (107), and range from mast cell mediator symptoms of itching, flush and hives, to very general symptoms like nausea, headache and irritability. Severe forms of systemic mastocytosis present with symptoms of bone marrow failure with cytopenia, weight loss, and subfebrility. The generality of the symptoms can make the diagnosis of systemic mastocytosis difficult (108). The genetics of mastocytosis is to some degree investigated; generally there is a mutation in the tyrosine kinase receptor KIT which renders the receptor constantly active, independent of its ligand stem cell factor (109). The vast majority of cases of systemic mastocytosis are indolent, with a normal life expectancy and little effect of quality of life when symptomatic treatment is administered at optimal levels. However, there is no available treatment that can remove the aberrant cells and cure the patient. There are however many new treatments under investigation (110). Due to the mutational alteration of the KIT receptor the first line of tyrosine kinase inhibitors have low effect on mastocytosis but there are several new TKIs showing promising effects.

1.2.2 Genetics

One single mutation, the exchange of an A to a T at codon 816 changing the amino acid from aspartic acid (D) to valine (V) in the kinase domain of the KIT gene, leads to the detrimental effect of ligand independent activation (111, 112). There is no need for SCF to be present since the KIT receptor is constantly activated and the mast cell will continue to grow and differentiate (113). Although the D816V mutation is by far the most common in systemic mastocytosis, other KIT mutations have been described (114-123). Some also located within the kinase domain are associated with more severe disease phenotype. Other mutations within the *KIT* gene but outside the activation loop have been described to associate with more benign forms of mastocytosis. Recent data show that additional KIT mutations will work synergistically with the D816V mutation and worsen the disease prognosis (109). The KIT mutations are somatic and thus not hereditary. Interestingly there are reports on familiar cases of systemic mastocytosis where a germ line mutation of *KIT* is present (124). This mutation is however not the D816V mutation common in most patients with adult onset.

Table 1, Kit mutations associated to different kinds of mastocytosis.

Kit mutation	Location	Associated form
C443Y, C419Y, InsFF419, T417Y, Y418Y	Extracellular domain	Cutaneous pediatric mastocytosis
Del419	Extracellular domain	Familial cutaneous mastocytosis
Dup(501-502)	Extracellular domain	Mast cell leukemia
K509I	Extracellular domain	Familial SM
A533D	Transmembrane domain	Familial cutaneous mastocytosis
F522C	Transmembrane domain	SM
D572A	Juxtamembrane domain	Cutaneous pediatric mastocytosis
V560G	Juxtamembrane domain	SM, Familial cutaneous mastocytosis
V559I	Juxtamembrane domain	Aggressive SM
R634W	Kinase domain	Familial cutaneous mastocytosis
InsV815-I816	Kinase domain	SM
D816F, D816H, D816L, D816V, D816Y	Kinase domain	SM, Aggressive SM, Cutaneous pediatric mastocytosis, Familial cutaneous mastocytosis
I817V	Kinase domain	SM
D820G	Kinase domain	Aggressive SM
N822I	Kinase domain	Familial cutaneous mastocytosis
E839K	Kinase domain	Maculopapular cutaneous mastocytosis

Other heterozygous somatic mutations commonly found in various myeloid hematological malignancies have also been found in systemic mastocytosis. Many of these are regulators of transcription and epigenetics: TET2 is a tumor suppressor gene which is involved in DNA demethylation. Loss of function mutations in the TET2 gene is one of the most frequent non-Kit mutations in mastocytosis (125). How TET2 contribute to disease progression is debated in one cohort it correlates to advanced forms of mastocytosis while in another study no such correlation was found (126, 127). By introducing the D816V mutation into TET2 mutated mast cells there is an increase of proliferation. Other epigenetic regulators ASXL1 and SRSF2 however are associated to poor prognosis not only in mastocytosis but also in other malignant myeloid malignancies (128, 129). The SRSF2-P95 hotspot mutation correlates to mastocytosis with associated clonal hematologic non-mast cell lineage diseases showing that an alteration of the mRNA splicing machinery in association to a KIT mutation lead to a more aggressive disease (130, 131). Further, epigenetics aberrations have been demonstrated in patients with systemic mastocytosis. Global levels of DNA hydroxymethylation in patients with mastocytosis would imply that there is the possibility of global destabilization of gene expression (132, 133).

1.2.3 Symptoms

The symptoms of mastocytosis vary depending on the tissue(s) affected. In cutaneous mastocytosis the skin is the only organ involved and the symptoms are mostly associated to the skin. For example itching, blistering and swelling. In systemic mastocytosis where there is mast cell infiltrate various organs the symptoms are greatly diverse. Symptoms can manifest chronically or at intervals. Often these attacks can be brought on by certain triggers like stress, physical exercise or rapid changes in temperature, also the intake of alcohol, certain food or drugs, can bring on an episode. Although the diversity is great almost all patient display some form of flushing. We strongly believe that systemic mastocytosis is an underdiagnosed disease, due to the fact that most symptoms are quite general like gastrointestinal problems, ulcers, heart palpitations, hypotension, osteoporosis/sclerosis, sweating, dizziness and headache. Furthermore, psychological symptoms like depression, irritation, concentration difficulties and anxiety have been observed. Sadly patients can live many years with undiagnosed and unmanaged disease. Anaphylaxis is a severe and rapid incident where the mast cell mediators bring on systemic vasodilatation causing a rapid blood pressure drop, often ending in syncope. Patients with systemic mastocytosis have a 1000 fold increased risk anaphylaxis compared to the general population. The experience from the mastocytosis center at Karolinska university hospital is that hymenoptera sting is frequently the anaphylaxis trigger (125, 126). Interestingly, there is no direct correlation between mast cell burden and degree of clinical symptoms (127). On the contrary, some patients suffer greatly from mediator symptoms yet there is no detectable mast cell increase, while other patients have massive mast cell infiltration in an organ but rather mild or even no symptoms. This has spurred the hypothesis that systemic mastocytosis mast cells are somehow more reactive, however this hypothesis has not been proven.

1.2.4 Diagnosis

Cutaneous mastocytosis is diagnosed from the visual skin symptoms and positive Darier sign (128). However skin biopsy can be used to determine the level of mast cell infiltration. Systemic mastocytosis cannot be diagnosed on the symptoms alone, but needs a biopsy of an involved organ (not skin), frequently bone marrow. In 2001 a consensus report was published presenting standardized diagnosis criteria to ensure correct evaluation of patients (129). The diagnosis criteria including one major and three minor; the major being presence of mast cell aggregate of 15 or more cells in the bone marrow or other organ however not the skin. The minor criteria are: A) more than 25% of the mast cells have abnormal spindle shaped morphology; B) CD117 positive cells also express CD2 and/or CD25; C) elevated levels of serum tryptase (>20 ng/ml); D) presence of the D816V KIT mutation, detected either in blood or tissue. If the major and one minor criteria or three of the minor criteria are fulfilled the patient is diagnosed with systemic mastocytosis.

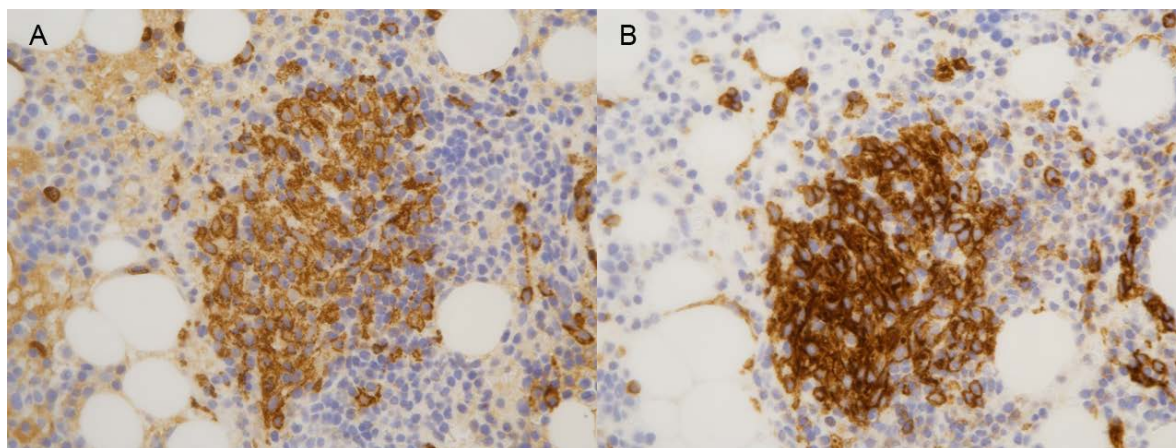

Figure 2, Examples of diagnostic histological staining of bone marrow. A) Tryptase staining show a mast cell aggregate of >15 mast cells. B) CD25 staining of the same infiltrate. Credit Igor Schliemann

1.2.5 Forms of mastocytosis and disease progression

There are three main forms of CM, maculopapular cutaneous lesions where brown spots appear on the skin where the mast cells aggregate, mastocytoma where the mast cells aggregate to one spot forming a lump, and diffuse cutaneous mastocytosis where mast cells infiltrate the entire skin (128). The typical maculopapular cutaneous lesions are divided into two subgroups. The monomorphic variant where small maculopapular lesions are found and the polymorphic variant where the lesions are larger and the shape and size are varied. Cutaneous mastocytosis of the polymorphic variant mainly affect children and the disease resolve itself at or just after puberty (130, 131). Some children exhibit the small maculopapular lesions commonly found in adults. These children often carry the disease into adulthood and develop systemic mastocytosis (132). Diffuse cutaneous mastocytosis is very rare (133). The children have no individual lesions rather a general mast cell infiltration of the entire skin. Their skin is thicker and prone to blistering even from mild irritation. Mastocytoma patients exhibit one or more large, brown nodules (134). They may display

symptoms like flushing, swelling and itch when the lesion is rubbed however patients may be entirely asymptomatic. Adult onset CM has a good prognosis but still reduce the quality of life of the patients from both cosmetic reasons and due to the skin irritation (128).

In systemic mastocytosis at least one organ other than the skin is involved, most often the bone marrow (129). Patients with the most common form of SM, indolent systemic mastocytosis (ISM) have low mast cell burden (135). The prognosis is good with normal life expectancy and high quality of life as long as symptoms are well managed. Some patients with the indolent form however develop a more aggressive disease over time. Detecting these patients prove a great challenge since most of them have the same KIT mutation. Many attempts have been made to find biomarkers identifying the patients who are at risk of disease development. So far elevated levels of IL-6 at the time of diagnosis associate with the progress of advanced disease in the future (136, 137). In systemic mastocytosis with associated hematologic neoplasm (SM-AHN) the symptoms and prognosis differ greatly depending on the associated disease (138). The associated disease is often of a myeloid origin as acute myeloid leukemia (AML) or chronic myelomonocytic leukemia (CMML) though it can be any hematologic malignancy (139). Both malignant components usually share common genetic abnormalities such as the activating KIT mutation or other mutations (140). TET2, SRSF2 and ASXL1 are frequently mutated in SM-AHN, recent investigations show these mutations precede the KIT mutation and that the presence of ASXL1 mutations associates to worsen outcome (141, 142). In the rare form aggressive systemic mastocytosis (ASM) the prognosis is poor since treatment options are few (143). In ASM there is often a considerable infiltration of mast cells in different tissues with resulting organ failure. Almost any organ may be affected but most commonly are the bone marrow and skeletal system, but also the liver, spleen and GI tract are frequently affected. The median survival is two to four years. However, ASM can develop into mast cell leukemia with dismal prognosis. In mast cell leukemia there is a rapid expansion of mast cell in many tissues, even in peripheral blood, and the prognosis is very bad with approximately six months survival (144, 145). It can be preceded by advanced forms of mastocytosis or be a de novo event. Interestingly mast cell leukemia is less frequently displaying the D816V KIT mutation; in fact there is a subgroup of patients with no KIT mutation at all (145). In mast cell sarcoma morphologically atypical mast cells form a large tumor which rapidly grow destroying the surrounding tissue (146, 147). It is a very rare disease with poor prognosis. Some patients have had pediatric mastocytosis which then has transformed into sarcoma but most are adult onset. Some sarcomas have the D816V mutation but it is not universal.



Figure 3, Representative skin changes. Maculopapular cutaneous lesions in adult patients with mastocytosis. Credit Theo Gülen

1.2.6 Treatment

Presently there is no curative treatment for systemic mastocytosis (110, 148). For most patients, the disease is indolent without progression, and with a normal life expectancy, and management of the symptoms is the key. Asymptoms vary so greatly between patients there is no straight line of treatment for all patients. Antihistamines are used to alleviate symptoms like pruritus and flushing (149, 150). H1 antihistamines are a diverse group of molecules which all block the H1 receptor on target cells thus inhibiting the reaction. The large variety of H1R-blockers makes it easier to fine-tune the therapy for each patient. H2 receptor blockers mainly target cells in the GI tract and is used to treat gastric hypersecretion and peptic ulcers. Ultraviolet light can alleviate symptoms of cutaneous mastocytosis (151). Both the lesions and the pruritus are significantly reduced by UV treatment however this treatment is in itself is carcinogenous and should be used with caution. Sodium cromoglycate effectively reduces gastrointestinal problems (152, 153). It stabilizes the mast cells by blocking calcium influx and thus degranulation. Leukotriene antagonists block the activation of leukotriene receptors on, e.g., smooth muscle cells. This may reduce respiratory and gastrointestinal symptoms (154). Omalizumab, a humanized monoclonal anti IgE antibody, has been used to alleviate symptoms in some patients with varying results (155, 156). More aggressive forms of systemic mastocytosis are met with more aggressive forms of treatment where the goal is to reduce the cell burden. Interferon α can reduce the mast cell burden and seem to somewhat stabilize the cells however there are severe side effects (157). Lower doses of interferon alfa in combination with high dose corticosteroids are more frequently used. Cladribine is a purine analogue shown to initiate remission but can also induce severe myelosuppression (158). Hematopoietic stem cell transplant can be effective in aggressive systemic mastocytosis, yet only younger patients are eligible (159).

1.2.7 Drugs in research

The need for better drugs inspire the field to do intensive research on finding new effective drugs that can actually treat the patients instead of merely manage the symptoms. The finding

that tyrosine kinase inhibitor imatinib was immensely effective in treatment of CML brought the hope that it could also be used to treat systemic mastocytosis. Mast cells with the KIT mutation D816V are resistant to imatinib due to structural changes brought on by the mutation (160). However, other kinds of tyrosine kinase inhibitors are under clinical investigation. Midostaurin is a TKI which have been shown to downregulate KIT autophosphorylation in mast cells with mutated KIT which are resistant to Imatinib (161). It has shown very promising results in clinical trials (162, 163). A majority of patients display reduced mast cell number in the bone marrow as well as serum tryptase levels even in very aggressive forms of MCL. Dasatinib is another TKI which induces apoptosis in KIT mutated mast cells and have shown promising result in clinical trial (164, 165). There are numerous other TKIs used mainly for research, the difficulty is to find a TKI that specifically target mutated KIT. Interestingly each KIT mutation will influence the morphology and activity of the receptor and thus alter the response to TKIs (166). By screening a library of small molecules BLU-285 was found to specifically inhibit KIT with the D816V mutation. It is presently in phase one clinical trial for treatment of advanced systemic mastocytosis, no NCT02561988.

Other targets downstream of the KIT activation pathway can be targeted by small molecular inhibitors. The JAK/STAT pathway is activated by phosphorylated KIT stimulating increased proliferation. The JAK/STAT pathway is also an important part of signal transduction in many cytokine receptors. JAK inhibitors have recently been tested in a few patients with advanced mastocytosis (167, 168). The resulting reduction of symptom burden was significant as was the increase of quality of life, however little or no reduction of mast cells or serum tryptase levels were seen. The PI3K pathway also contains numerous promising targets. Pan inhibition of PI3K itself is associated with high toxicity but has shown to inhibit proliferation of mutated mast cells in a murine model (169). Idelalisib is a new PI3K inhibitor targeting the active subunit preferential in hematologic neoplasms and it has been shown to be very effective in the treatment of CLL (170). Another second generation PI3K inhibitor LY294002 successfully inhibit proliferation in KIT mutated mononuclear cells (171). mTor a downstream target of the PI3K pathway is upregulated in neoplastic mast cells and inhibition of mTor induces apoptosis in KIT mutated mast cells *in vitro* (172, 173). However the first clinical trial of the usage of an mTor inhibitor in treatment of systemic mastocytosis failed to show clinical relevance (174). To increase efficacy dual inhibitors targeting PI3K and mTor simultaneously has been developed. The dual PI3-kinase/mTOR blocker NVP-BEZ235 currently in multiple clinical trials has been shown to induce apoptosis in human mast cell lines 1.1 and 1.2 (175). The effect on mast cell survival is even more pronounced when combined with Stat-5 inhibition (176). Akt is the dominant actor in the PI3K pathway and several AKT inhibitors have been developed and is in clinical trials, however, they have not yet been tested in mast cells (177). Small molecular inhibitors can also be utilized in targeting the Bcl-2 family members. They are proteins regulating cell survival and apoptosis via intricate homeostasis. Obatoclax was the first pan inhibitor of the Bcl-2 family to be introduced in clinical trial. It has been shown to induce apoptosis in mastocytosis cell lines

alone and in synergistic effect with a tyrosine kinase inhibitor (PKC412). Our group has investigated the effect of ABT-737, a BH3 mimetic, inhibiting Bcl-2, Bcl-XL and Bcl-w that effectively induces apoptosis in mast cells (178). In paper IV we show that it works synergistically with the Mcl-1 inhibitor Roscovitine to induce apoptosis in KIT mutated mast cells.

Another way to attack the mast cells is to target surface markers which are expressed by neoplastic mast cells. CD123, the alpha chain of the IL-3 receptor, is expressed on some aberrant mast cells (179). CD123 can be targeted by SL-401, a molecule where the catalytic and transmembrane domains of diphtheria toxin have been fused together with IL-3 (180). It would directly target and kill cells expressing CD123. It is presently in clinical trial for usage against systemic mastocytosis (no NCT02268253). Antibodies may also be used to target the surface molecules. Bretuximab vedotin is an antibody-drug conjugate consisting of chimeric antibodies binding CD30 connected to monomethyl auristatin E an antimitotic agent. CD30 is overexpressed by neoplastic mast cells in many patients with ASM or MCL and the drug has been tested in a few patients resulting in a normalization of bone marrow composition (181-183). Targeting CD52 *in vitro* induces apoptosis in neoplastic mast cells (184). This short description of the research in development of new treatment options for mastocytosis indicates the difficulty to treat this heterogeneous disease.

1.3 REGULATION OF MAST CELL SURVIVAL AND APOPTOSIS

1.3.1 Introduction

The body is an organism in constant development. Cells develop in response to different stimuli and some of them like the tissue-residing mast cells will survive for a very long time while other cells like the intestinal epithelial cells are constantly renewed. There is a fine balance between life and death in the cellular world. This is why it is so strictly monitored by multiple control layers. Too much survival will lead to cancer while too little survival leads to ischemic and neurodegenerative disease. Apoptosis is controlled cell death where the cell follows a specific route ending in its degradation and engulfment without spilling any internal cell substances which could potentially harm the surrounding tissue. Apoptosis is vital in normal development but can be detrimental if activated under the wrong circumstances. Many of the genes involved in apoptosis regulation are implicated in cancer development.

1.3.2 The Bcl-2 family

The B-cell lymphoma 2 (Bcl-2) family members are important regulators of cell survival and apoptosis (185). The Bcl-2 gene family consists of the pro-survival proteins; Bcl-2, Bcl-xL, Bcl-w, Mcl-1, Bfl-1 and the pro-apoptosis proteins divided into the Bax-subfamily and the BH3-subfamily. The pro and anti-apoptotic family members bind to each other in order to inhibit the function and block the binding sites of their counterpart (186). The BH3-only family members can inhibit the function of the pro-survival proteins which in turn inhibit the effector proteins Bax/Bak. Intracellular stress signals will increase the expression of the pro-apoptotic and reduce the expression of the pro-survival family members. The pro-apoptosis proteins induce mitochondrial membrane permeability and release of cytochrome c into the cytoplasm. Together with apoptotic protease activating factor 1 (APAF1) cytochrome c will form the apoptosome which then recruits and activates caspase-9 (187). Active caspase-9 will cleave and activate the executioner caspases -3, -6 and -7. They will in turn start cleaving cellular content thus starting degradation (188). Inhibitors of apoptosis proteins (IAPs) are the last layer of apoptosis regulation (189). They bind to the executioner caspases and inhibit them by catalyzing ubiquitination and by physically blocking the substrate.

The Bcl-2 family is vital in regulating mast cell survival and apoptosis. SCF signaling leads to increased expression of pro-survival proteins Bcl-2 and Bcl-X_L (190). SCF has been shown to regulate mast cell survival by repressing the transcription of Bim and phosphorylation of the Bim protein that makes it vulnerable for proteasomal degradation (57, 190). Bcl-2 and Bcl-X_L have been proven to be essential in the development of murine mast cells both *in vitro* and *in vivo* (191, 192). Other cytokines are indispensable for mast cell survival where Puma as well as Bax and Bak that have been shown to induce apoptosis following cytokine deprivation (193, 194). Alterations of the expression of members in the Bcl-2 family can be detected in many forms of cancer. In mastocytosis both Bcl-2 and Bcl-X_L can be detected at higher levels in patient samples (195, 196). Inhibiting pro-survival members of the Bcl-2 family using small molecules is a way to induce apoptosis. As

previously mentioned our group has investigated the effect of ABT-737 a BH3 mimetic inhibiting Bcl-2, Bcl-XL and Bcl-w (178).

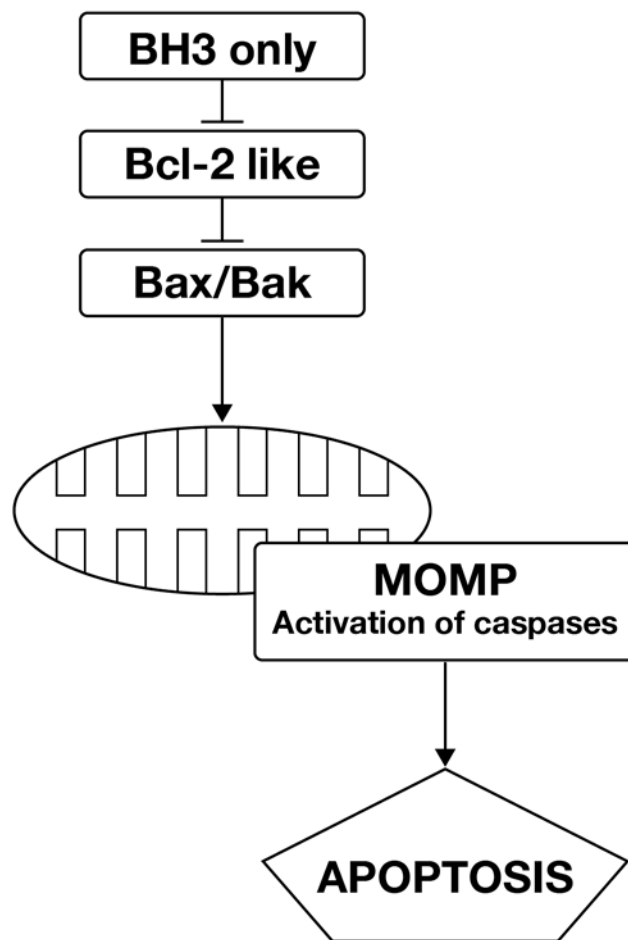

Figure 4, Illustration of the Bcl-2 family. There is an intricate balance between the pro and anti-apoptotic members of the Bcl-2 family. The increase of Bax and Bak will lead to MOMP and the subsequent release of cytochrome C, activation of caspases and apoptosis. Bax/Bak is in turn inhibited by the anti-apoptotic Bcl-2 like proteins which are inhibited by BH3 only proteins.

1.3.3 Activation induced survival

Our group has intensively studied the mechanism for activation-induced mast cell survival. When the antigen binds to the IgE molecules on the FcεRI receptor it leads to receptor cross-linking and the degranulation cascade is induced. Certain mast cells have the ability to survive, regranulate and thus be activated again. This is mainly controlled by the Bcl-2 family member A1 (197-199). The FcεRI activation leads to the translocation of NFAT from the cytosol to the nucleus and the subsequent transcription of A1 (200). Interestingly there is a difference in the capability to survival after receptor crosslinking between the two mast cell types (201). Investigating the *in vitro* cultured mast cells mimicking the two subtypes show that the short-lived mucosal mast cells have no A1-induction and no increased survival while the long lived connective tissue mast cells induce A1 expression and display activation induced survival upon IgE receptor cross-linking. Mice lacking the A1 gene have

significantly reduced numbers of connective tissue mast cells and the mice have dramatically reduced response to induced anaphylaxis (199). There is a significant upregulation of the human homolog Bfl-1 in mast cells in birch-pollen provoked skin (202). Bfl-1 expression is induced not only by cross-linking FcεRI but also FcγRI indicating that activation-induced survival occurs not only in allergic diseases but also in diseases where IgG is the main immunoglobulin (203).

1.4 EPIGENETICS

1.4.1 Introduction

Each cell of the body contains the same DNA although they have fundamentally different commitments. This is because the entire DNA is not active all the time, the same genes are not transcribed in all cells and if they are transcribed the amount of protein produced is very different. Epigenetics is defined as stably heritable phenotype resulting from changes in a chromosome without alterations in the DNA sequence. This involves everything from how the DNA sequence is accessible for the transcriptase via the folding of the DNA determining the proximity of regulating elements to the DNA sequence of interest to how the mRNA is controlled. In 1957 Conrad Hal Waddington founded the metaphor of the epigenetic landscape to describe how gene regulation modifies cellular evolution. In cancer the epigenetic regulation is often distorted at all levels.

1.4.2 DNA structure

The DNA forms a double helix with strands running in opposite directions (204). The helix is wrapped around the nucleosomes 1.65 times (205). The nucleosomes are cores formed by two copies of each of the four histones H2A, H2B, H3 and H4 (206). Histones are highly alkaline proteins each histone has both a C-terminal and an N-terminal tail. The fifth histone, H1, keep the DNA connected to the nucleosome. The nucleosomes fold up the chromosome fiber which loops and coils again (207). The chromosome can open and close depending on the need for the transcription machinery to access the DNA.

1.4.3 DNA modifications

Our genome contains large regions of genetic information that is not supposed to be transcribed. They are e.g. pseudogenes, repetitive elements and transposons but also genes which are transcribed only during development. These regions are effectively silenced without any effect on the surrounding genes by the addition of a methyl group to cytosine thus forming 5-methylcytosine (5mC) (208). Methylation of a cytosine nucleotide usually occurs when it is followed by a guanine nucleotide, a CpG. They cluster together forming CpG islands which often locate in promotor and other regulatory regions. The effect of the methylation is a blockade of binding sites for the transcription machinery but also the binding of proteins that influence the chromatin structure (209, 210). Demethylation is vital during development. Recent discoveries show that thymine DNA glycosylase in collaboration with Tet enzymes can transform 5-methylcytosine to form 5-hydroxymethylcytosine (5hmC) (211, 212). Tet enzymes can further oxidize 5hmC to form 5-formylcytosine (5fC) and 5-carboxycytosine (5caC) (213).

1.4.4 Histone modifications

The N-terminal histone tails protruding from the nucleosome can be chemically modified which regulate the availability of the DNA strain (207). Methyl groups are added to the tails on histones 3 and 4 by histone methyltransferases while they may be removed using histone

demethylases (214, 215). Methylated histones can either repress or activate transcription depending on which of the histone tails are methylated and how many methyl groups are transferred. For example adding three methyl groups to H3K9 will bind heterochromatin protein 1 continuously closing the DNA for transcription (216). Histone deacetylases and transferases move acetyl groups to and from the histone tails (217, 218). Acetyl groups on the histone tails will reduce the interaction between the nucleosome and the DNA relaxing the DNA (219). Histone deacetylase inhibitors keep the DNA relaxed by inhibiting the removal of the acetyl groups (220, 221).

1.4.5 Micro RNA

MiRNAs are short sequences of approximately 22 nucleotides. They bind to the targeted mRNA sequence retaining them in the cytosol and thus regulating what proteins are in the end translated. They were first described in *C. Elegans* by Dr Ambrose in the beginning of the 1990th, however it would take a decade before the field of miRNA research was to gain momentum (222). Then the miRNA Let-7 was found to be crucial for developmental timing in *C. Elegans* (223). The family of Let-7 is unusual in the way that if they are silenced the effect on the organism is detrimental (Let=Lethal) (224). 15 years later we now know that most miRNAs can be taken out without such massive impact on the organism. They rather seem to be guardians of the cell to step into action when the cell is stressed by environmental factors like changes in osmotic pressure (225). The miRNA mechanism is highly conserved found in plants, animals and even in some viruses though with minor differences in target recognition (226-228).

The miRNA genes are often found in introns. They are transcribed by RNA PolIII/III and the RNA forms a pri-miRNA (229, 230). It is then cleaved into pre-miRNA by the enzyme Drosha and DGCR8 and forms a hairpin (231, 232). The hairpin is transported out from the nucleus by exportin -5 (233). In the cytoplasm the Dicer and TRBP enzymes cleave of the hairpin loop and divide the strands (234). The mature miRNA is then loaded into the RISC complex by Ago2 (235). Once located there the miRNA is highly stable (236). When mRNA is released from the nucleus it has to pass by a cloud of miRNA-RISC complexes. The mRNAs which show a specific target sequence will interact with the miRNA and will be retained in the cytosol never to reach the ribosome. There has been a deliberation regarding if the mRNA is degraded or only retained for a period. It has been shown that at least to some degree the miRNA guide the mRNA to the general eukaryotic machinery for mRNA degradation (237, 238).

Recent studies implicate miRNAs in directing myeloid development (239). Mir-27a has been shown to be important in myeloid development. It regulates the expression of GATA2, a transcription factor regulating hematopoiesis as well as mast cell development (240, 241). The mir-221/222 cluster has the ability to directly target KIT mRNA but has also been shown to indirectly inhibit Slug, a negative regulator of KIT (242, 243). In other cell systems KIT is directly targeted and down regulated by the mir-221/222 cluster (244). The cluster is upregulated upon mast cell activation but seems not to directly influence viability (245).

Instead cell cycle inhibitor p27^{kip1} is the effected target inhibiting proliferation and stem cell accumulation. Following studies indicate that mir-221 is a major regulator of mast cell effector functions as degranulation and migration due to cytoskeletal deregulation (246). Alteration of the mir-221 seed sequence in the KIT 3'UTR correlate with increased risk of acral melanoma (247). Mast cell viability and homeostasis is regulated by mir-146a (248). Extensively implicated in allergic diseases Mir-155 is a regulator of mast cell effector function by targeting parts of the signal transduction. Mir-155 knockout mice display significantly increased passive anaphylaxis due to the alteration of the PI3K γ pathway (249). Anaphylaxis is on the other hand reduced in mir-155 deficient mice in response to IL-10 treatment via the alteration of Stat3 expression (250). In mast cell neoplasms the expression of mir-539 and mir-381 is reduced by KIT signaling and subsequently the target MITF is upregulated contributing to cell proliferation. (251). KIT is also the target of mir-193a (252). Mir-193a was found to be repressed in KIT mutated blast cells and when the expression was restored or mimicked the KIT expression was reduced and cell growth inhibited.

2 THE PRESENT STUDY

2.1 AIM

The overall aim of the study presented in this thesis was to investigate mast cell function in health and disease.

The specific aims for papers I-VI were:

Paper I: To study the *in vivo* reactivity of mast cells in patients with systemic mastocytosis.

Paper II: To investigate the *in vitro* reactivity and genetics of mast cells developed *in vitro* from progenitor cells enriched from patients with systemic mastocytosis.

Paper III: To analyze the sensitivity of KIT mutated mast cells to combinatorial treatment with ABT-737 and Roscovitine.

Paper IV: To explore the effect of the deacetylase inhibitor SAHA on a KIT mutated cell line and primary bone marrow cells.

Paper V: To examine the dependence of Bfl-1 for activation-induced mast cell survival.

Paper VI: To reveal the *in vivo* function of the pro survival gene A1.

2.2 MATERIAL AND METHODS

The methodology used in the study is briefly described herein. For a more detailed description please see papers I-VI.

Chromatin immunoprecipitation

ChIP assay was performed by crosslinking the chromatin to regulatory proteins using formaldehyde. The isolated nucleus was shredded and protein modifications of interest were extracted with bead separation. DNA was released from the protein and analyzed with PCR.

Basophil Histamine release assay

Blood donated from patients and health subjects were washed and incubated on the assay plates coated with anti-IgE for 30 minutes at 37°C before the plates were washed and sent to RefLab Aps for analysis on the Histareader™

Enzyme linked Immunosorbent assay (ELISA)

ELISA was used to measure the release of prostaglandin D₂ from human cultivated mast cells and to measure the release of murine mast cell protease 1 and 2.

Flow cytometry

Flow cytometry was used in most studies to analyze surface receptor expression using monoclonal antibodies with conjugated flourophores. It was also utilized in investigating the cell vibility by staining the cells with propidium iodine and AnnexinV.

Histamine assay

Supernatants from activated mast cells was incubated on the assay plates at 37°C for 30 minutes before the plates were washed and sent to RefLab Aps (Copenhagen, Denmark) for analysis on the Histareader™

Histology

Human tissue samples were taken using a 3 mm disposable punch, under local anaesthesia. Samples were snap frozen, embedded immediately in TissueTek OCT medium and stored at 70°C. For staining, 6 mm thick sections were cut by cryostat. Tryptase containing cells were visualized using Z-Gly-Pro-Arg-4-methoxy-2-naphthylamide and Fast Garnet GBC. The protein of interest was stained immunohistochemically. Murine tissue specimens were fixed with paraformaldehyde and embedded in paraffin. Four-micrometer sections were stained with toluidine blue and fast green for histological examination and enumeration of mast cells

In vitro cultures of human mast cells

Peripheral blood mast cells were developed from whole blood donated by healthy controls or subjects recruited via the Mastocytosis center Karolinska where they were clinically evaluated. The CD34+ cells were separated using magnetic bead separation and were cultured for approximately seven weeks under both hypoxic and normoxic conditions with a cocktail of cytokines including SCF, IL-6, IL-9 and IL-4, as described by Lappalainen et al (253). At the end of the culture period the maturation of the cells was determined by enzymatic staining for tryptase activity. Cord blood derived mast cells were cultured from donated umbilical cord blood. Progenitor cells were cultured in StemPro medium supplemented with IL-3, SCF and IL-6. All participants were informed and provided their written informed consent to participate.

In vitro culture of murine mast cells

Connective tissue mast cells were derived from bone marrow by culturing the cells in RPMI 1640 with supplemented with FBS, L-glutamine, sodium pyruvate, nonessential amino acids, penicillin, streptomycin, 2-ME, SCF and murine IL-4. Mucosal-like mast cells were produced by culturing bone marrow cells in DMEM with FBS, L-glutamine, sodium pyruvate, penicillin, streptomycin, SCF, human TGF- β 1, murine IL-9 and murine IL-3. Peritoneal cell-derived mast cells were generated by cultivating peritoneal cells in Opti-MEM complemented with FBS, L-glutamine, penicillin and SCF containing hybridoma supernatant harvested from CHO-KL cell cultures or murine SCF.

Mast cell activation

Mast cells both human and murine were activated for 30 min at 37°C before the reaction was stopped on ice. IgE-receptor activation was performed by incubating the human mast cells with IgE for 24 hours before being washed and anti-IgE was added. They were also activated with ionophore A23187, Morphine and Mannitol. Murine mast cells were sensitized with IgE by incubation with 15% hybridoma supernatant containing 1 mg/ml monoclonal mouse anti-2,4,6-trinitrophenol (TNP) IgE Ab (IgE1-b4; American Type Culture Collection) for 90 min. The cells were then stimulated with 100 ng/ml TNP-BSA or ionomycin alternatively ionophore A23187. The supernatants were spun down and stored at -70°C until time for analysis.

Mast cell lines

The human mast cell lines HMC-1.1 and HMC-1.2 (were maintained in IMDM (Sigma) supplemented with 10% FCS, 2 mM L-glutamine, 100 IU/ml penicillin/streptomycin and 1.2 mM monothioglycerol (254, 255). The human mast cell line LAD-2) was maintained in supplemented StemPro-34 SFM medium with 100 ng/ml SCF (256).

Measurement of mast cell mediators in blood and urine

Serum tryptase levels were measured with the ImmunoCAP® tryptase assay. The major urinary histamine metabolite tele-MIAA was measured by LC/MS and values were expressed as micromole per milimole creatinine (257). The early PGD₂ metabolite, 11 β -PGF_{2 α} , was measured in urine using a commercial enzyme immunoassay kit (Cayman Chemical Co., Inc., Ann Arbor, MI). Urine creatinine concentrations were measured by automated colorimetric Jaffe method.

Methacholine and Mannitol provocation test

Methacholine (MCh) (prepared at Karolinska University Hospital Pharmacy, Stockholm, Sweden) inhalation challenges were performed using a dosimeter-controlled jet nebulizer (Spira Electro 2; Respiratory Care Center, Hämeenlinna, Finland). For Mannitol provocation test, mannitol capsules (Aridol, Pharmaxis, Frenchs forest, NSW, Australia) were inhaled using a dry powder inhaler (Plastiap, Osnago, Italy). The challenge was initiated with an empty capsule and FEV1 was measured in duplicates 60s later. If the fall in FEV1 was <10% from baseline value, challenge proceeded, commencing with 5 mg of mannitol. Spirometry was performed 60s later and if the fall in FEV1 was < 15%, the dose of mannitol was increased stepwise (10, 20, 40, 80, 160, 160, 160 mg) until the fall in FEV1 was >15% or the maximum cumulative dose (635 mg) according to the protocol had been administered.

microRNA analysis

RNA was extracted using Trizol though isopropanol was exchanged for ice-cold absolute ethanol. The RNA was treated with heparinase for two hours at 25°C and then analyzed with qPCR or with Affymetrix® miRNA array 2.0 at the core facility for bioinformatics and expression analysis, Karolinska Institutet.

Passive cutaneous anaphylaxis

Mice under anesthesia and analgesia were sensitized passively with IgE by intradermal injection in the ear pinnae of DNP-specific IgE antibodies or with PBS and were challenged 24 hours later by intra venous injection with DNP. Ear swelling was measured immediately before and at 30-min intervals after antigen challenge for 6 h using a micrometer.

Passive systemic anaphylaxis

Mice were sensitized passively with IgE by intra peritoneal injection of DNP-specific IgE antibodies in PBS and then challenged 24 hours later with DNP in PBS. Body temperature was measured directly before and at 5-min intervals after antigen challenge for up to 1 hour.

Quantitative polymerase chain reaction

RNA was translated into cDNA by reverse transcription. The cDNA was amplified using gene specific primers that were either purchased ready-made or designed using Primer3+.

Reduction of gene expression using small interfering RNA

Cells were transfected using a gene specific siRNA pool with five siRNAs targeting different sequences in the target RNA. siRNA was introduced using an Amaxa Nucleopator. 24 hours post transfection dead cells were removed and the effect on gene inhibition was measured with qPCR.

Serum concentration of IgE

The serum concentrations of IgE (kE/L) were determined with (ImmunoCAP[®] Total IgE, ThermoFisher, Uppsala, Sweden). The specific IgE antibody test (ImmunoCAP[®] Phadiatop[®], ThermoFisher) was applied in six patients.

Skin prick test

Skin prick testing (SPT) was performed with commercial extracts of standard aeroallergens (birch, timothy grass and mugwort pollens, cat, dog and horse dander, house dust mites, moulds) and food allergens (milk, egg, nuts, cereals, codfish, shrimp), and hymenoptera venom (bee and wasp). Additionally, SPT with the MC secretagogues morphine (10 mg/ml) was performed. As a positive and negative control we used histamine dihydrochloride 10mg/ml and saline (NaCl 0.9%), respectively. A skin test panel was considered positive if the wheal diameter was at least 3 mm larger than that elicited by the saline control.

Statistical analyses

The statistical analyses were performed using GraphPad Prism version 5 and differences were considered significant if $p < 0.05$. All data have been presented as mean and SEM unless otherwise stated. Commonly student T-tests were used in two group comparisons and two-way ANOVA with bonferroni posttest was used in multiple group comparisons.

Study subjects

In study I and II, 15 cases (≥ 18 years) with systemic mastocytosis (5 men and 10 women), with a median age of 48 years (21 to 69) were recruited. 13 healthy volunteers (eight women, five men), aged 22 to 55 years with no history of allergic diseases, and 11 subjects with allergic asthma (eight men, three women), aged 22 to 52 years constituted the control groups for the study. Exclusion criteria were usage of beta blockers; inability or refusal to undergo a bone marrow biopsy and aspirate, subjects with HIV or other known immunodeficiency, carcinoid syndrome, pheochromocytoma, pregnancy.

Transgenic mice

VVA1 and VVFF transgenic mice were generated by Dr Ottina at Innsbruck medical university (258). In our studies mice with a C57BL6 background was used. 6-12 old mice were used during the experiments according with Austrian legislation (BMWF-66.011/0112II/3b/2012).

Western blot

Cell lysate was separated with gel electrophoresis and transferred to a membrane where proteins were visualized using specific antibodies.

2.3 PAPER I; ANALYSIS OF IN VIVO MAST CELL REACTIVITY IN PATIENTS WITH SYSTEMIC MASTOCYTOSIS.

Patients with systemic mastocytosis suffer from mediator related symptoms and in more severe cases organ failure due to mast cell infiltration. One hypothesis is that individuals with systemic mastocytosis have mast cells with a more reactive phenotype, though this has never been proven scientifically. The aim of this study was to investigate whether patients with systemic mastocytosis have altered mast cell reactivity in vivo and/or if the target tissues have developed resistance to the circulating mast cell mediators. In this study we used two controls groups, healthy non-atopic controls and allergic asthma, the latter in order to compare to another mast cell associated disease. First we analyzed baseline levels of serum tryptase and the urinary metabolites of histamine, 1-methyl-4-imidazoleacetic acid (tele-MIAA) and the PGD2 metabolite 11β - PGF $_{2\alpha}$. We also examined the histamine release from basophils, since the functionality of basophils in SM has previously not been examined and these cells could be a potential source of histamine. To investigate the reactivity of the target tissues we evaluated whether tissue responsiveness was altered in SM patients by skin prick test with morphine and histamine; and provocation with mannitol and methacholine of the airways.

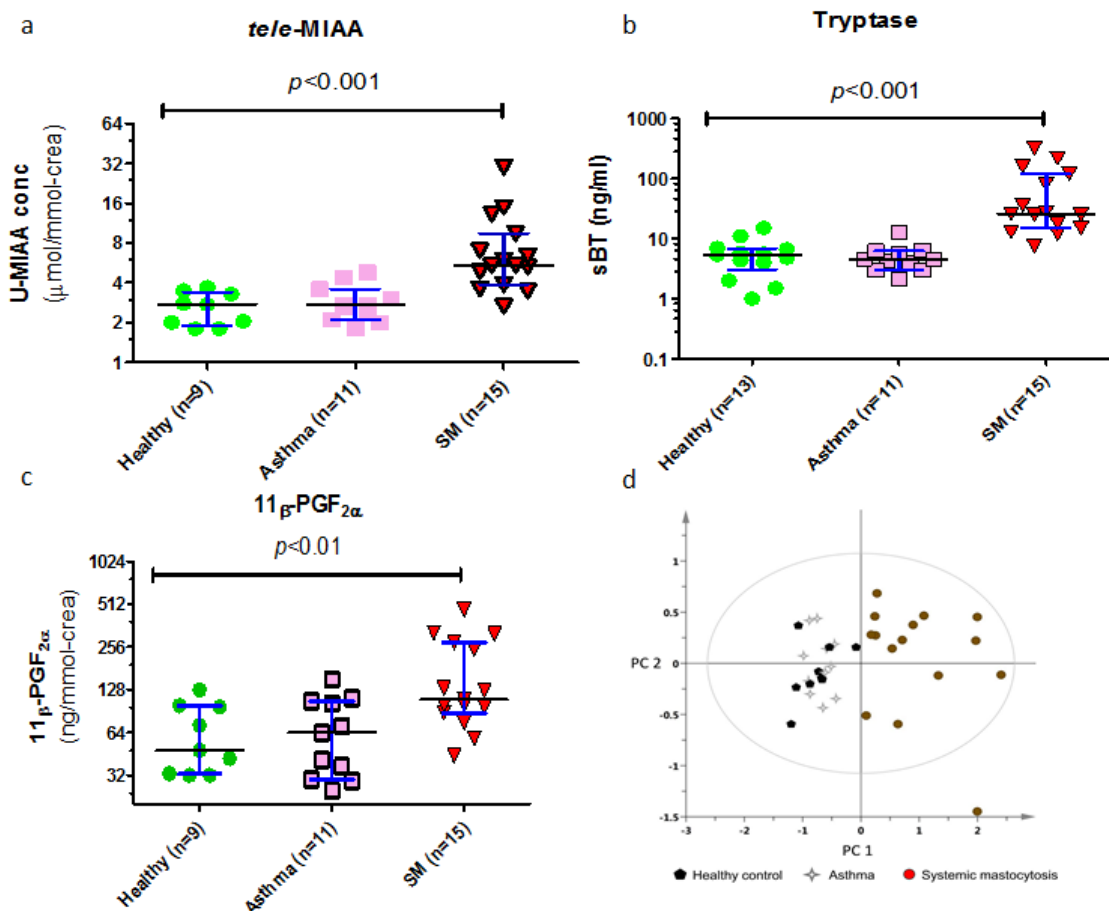

Figure 5, Serum and urinary analysis of histamine, tryptase and PGD2. A) Urinary levels of the major histamine metabolite tele-MIAA. B) Baseline serum tryptase levels (sBT).

C) Urinary levels of 11β -PGF 2α , a metabolite of PGD 2 in healthy controls and subjects with asthma or systemic mastocytosis (SM). The values presented are medians with interquartile ranges. D) Principal component analysis (PCA) of the relationships between tryptase, tele-MIAA and 11β -PGF 2α based on variance analysis, employing 62 urinary spot samples (performed in duplicate) and 31 serum samples. These variables were log-transformed and Pareto scaled. The extent of the variance explained by PC1 and PC2 was 79 and 14%, respectively. The extensive increase in their concentrations in some of the SM patients is reflected in the spread along PC1 axis. The SM patients formed a cluster that was clearly distinguishable from both the patients with asthma and the healthy controls.

Serum tryptase as well as the urinary metabolites of histamine tele-MIAA and PGD 2 11β -PGF 2α , were significantly increased in patients with SM compared to the controls and formed a distinct group in a principal component analysis (Figure 5). Both patients with SM and controls showed an increase of release of histamine from basophils in a dose dependent way, however, there were no discernible differences between the groups. For the skin prick test we could not detect any differences between the groups, neither in response to morphine or histamine. Likewise there was no indication of increased airway reactivity in patients with SM, i.e., no increase in airway responsiveness to mannitol or methacholine.

In this study we demonstrate that patients with systemic mastocytosis have increased systemic levels of mast cell mediators, as previously described. Even so when mast cell stimulus was applied locally, in the skin and airways, there were no discernible differences in response between the groups. One hypothesis was that the end organs have somehow developed a resistance to the mediators. But when a pure mast cell mediator, i.e., histamine, was added locally to the skin, or methacholine was inhaled, the same response was recorded in individuals with systemic mastocytosis as in the control groups. It is well known that patients with mastocytosis have increased levels of circulating mast cell mediators. Since we could not provide data supporting the hypothesis of a hyperactive mast cell phenotype in systemic mastocytosis one interpretation of the data is that the increase in mast cell mediators is due to the increased number of mast cells. However, there might be a dysfunctional regulation of biosynthesis, storage or release of the mast cell mediators. Furthermore, we have in this study only investigated mast cells in the skin and in the airways, whereas SM patients are more prone to cardiovascular effects of mediator release rather than respiratory effects. Thus reactivity among mast cells might differ in different tissues in SM. Furthermore, SM patients are more prone to MC activation events following physical stimuli such as friction, temperature changes and exercise rather than pharmacologic stimuli.

In conclusion we show that patients with systemic mastocytosis do not exhibit mast cell hyperreactivity *in vivo*. Neither is there evidence of a tissue resistance development as assessed by challenge with histamine or methacholine. Furthermore, no evidence of increased basophil reactivity was detected in these patients. Our results suggest that the increased levels of mast cell mediators are due to the increase in mast cell numbers, but other dysfunctions in mediator synthesis, storage and release, or mast cell reactivity to other type of stimuli cannot be ruled out.

2.4 PAPER II; MAST CELLS FROM PATIENTS WITH MASTOCYTOSIS SHOW ALTERED MIRNA PROFILE AND OSMOTIC INDUCED HYPERREACTIVITY

Paper II is another arm of the study on systemic mastocytosis. Whereas we in paper I investigated mast cell reactivity *in vivo*, in this part, paper II, we investigated mast cells *in vitro*. Here we aimed to further investigate the possibility of a hyperreactive mast cell phenotype and discern genetic differences beyond the KIT D816V mutation. Mast cells were developed in vitro from enriched CD34+ cells cultured in a cocktail of cytokines, including SCF. When cultures had reached a level of 90% tryptase positive cells, approximately seven weeks in culture, they were considered ready to be used. All patients with systemic mastocytosis carried at time of diagnosis mutated KIT in the bone marrow cells. However PCR specific to the D816V mutation revealed that none of the mast cell cultures harbored the mutation, suggesting that the CD34+ progenitor cells are D816V KIT negative. There were no differences between the groups in regard to the number of cells obtained at the end of the culture period. Surface expression of the FcεRI receptor was analyzed using flow cytometry and there was a trend pointing to increased expression of the receptor on cells from SM patients. We could not detect any differences between the groups in regard to the levels of histamine released after activation with calcium ionophore A23187, anti-IgE, morphine or mannitol (Figure 6 A). However the cells from the SM patients released significantly more PGD₂ after activation with mannitol indicating a hyperactive cell type in response to alteration in osmolarity (Figure 6 B).

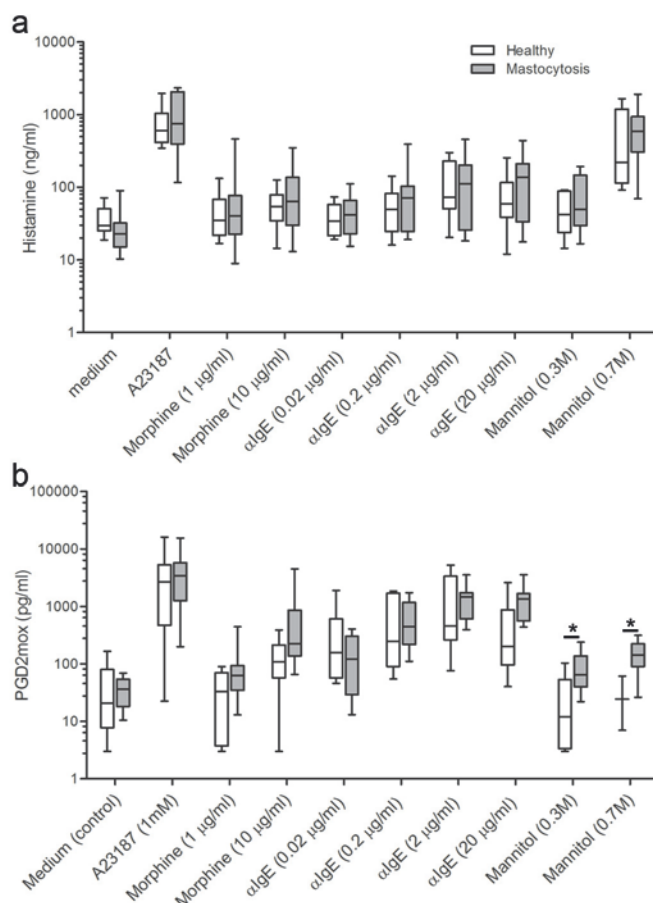

Figure 6. Release of histamine and PGD2 from activated in vitro developed mast cells. Mast cells were treated for 30 minutes with calcium ionophore A23187, morphine, mannitol or anti-IgE and the release of histamine (A) and PGD2 (B) was measured in the cell free supernatant. Healthy controls (open boxes)(n=6) and systemic mastocytosis (filled boxes)(n=11).

Total RNA was analyzed on an Affymetrix® miRNA array 2.0 to investigate the expression of 4544 noncoding RNAs in mast cells developed from SM patients and healthy controls, respectively. 13 miRNAs were identified with significantly different expression ($p=0,001$, $q=0,36$), either upregulated or down regulated, in cells from SM patients $n=4$ compared to healthy control $n=3$ (Figure 7 A). Interestingly all of the miRNAs proved to have targets within the KEGG pathway of inflammatory mediator regulation of Transient Receptor Potential (TRP) channels. The subfamily of TRPV has been shown to contribute to how the nervous system is able to detect changes in osmolarity (259, 260). We further analyzed the mRNA of three patients and two controls in order to narrow down the possible miRNA targets using the PrimeView™ Human gene array (Figure 7 B). It resulted in 47 differentially expressed mRNAs. Four miRNAs had numerous targets within the deregulated mRNAs. The antisense RNA of the gene ABCC5 is a target of three of the upregulated miRNAs and is significantly down regulated in the patients (Figure 7 C). This antisense RNA has the ability to bind to the mRNA of ABCC5 and obstruct the receptor expression on the cell surface. Furthermore, ABCC5 is a member of a family of transporter proteins known to be responsible for the exodus of prostaglandins (261).

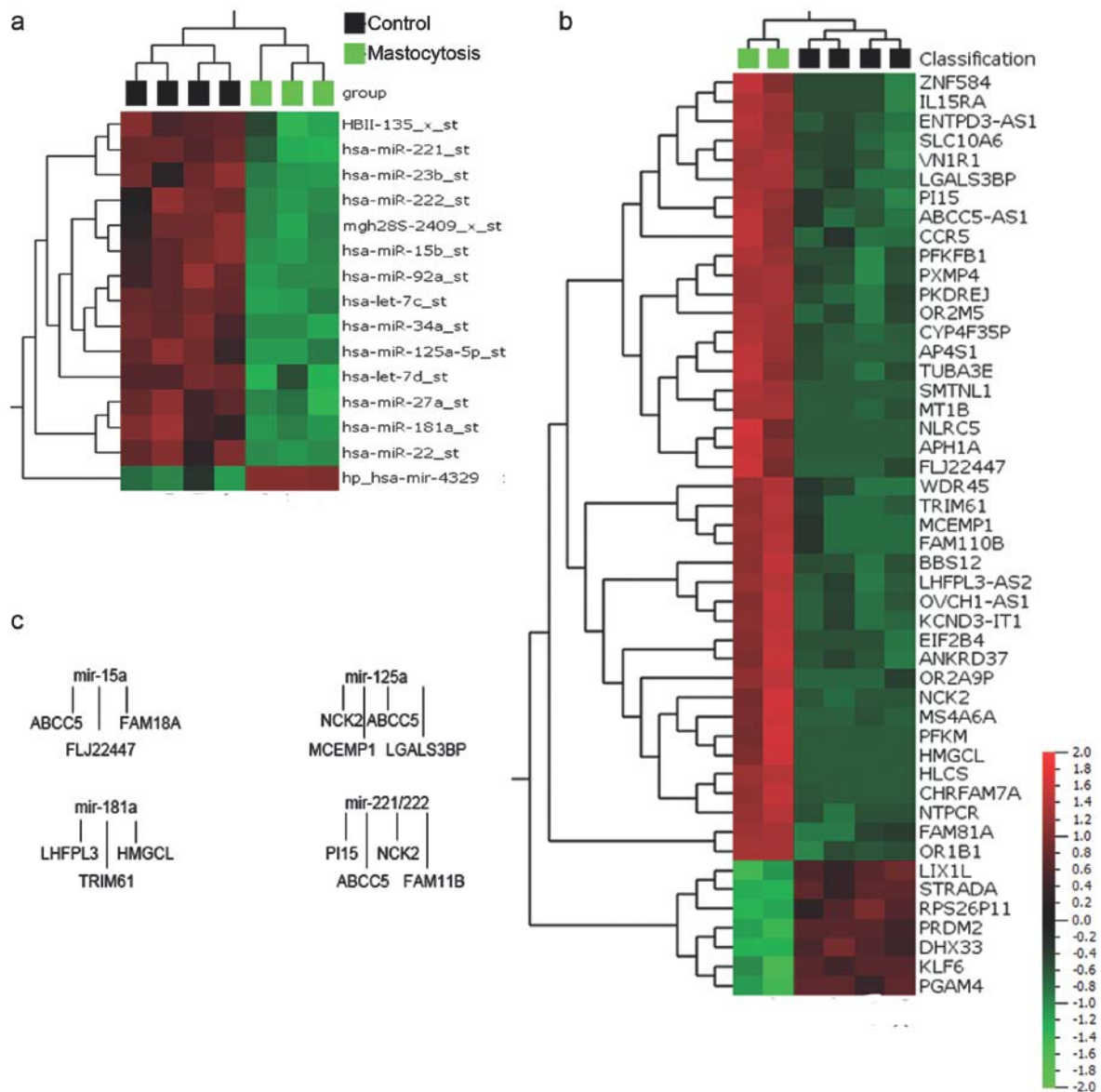

Figure 7. miRNA and mRNA expression in in vitro developed mast cells. (A) miRNA expression (B) mRNA expression (C) mRNAs with target sequences for the detected miRNAs.

In conclusion we show that mast cells cultured from progenitors retrieved from patients with mastocytosis release significantly less PGD2 than control cells. Analyzing the RNA we found a specific miRNA and mRNA profile for Mastocytosis. The deregulation of ABCC5 may explain the differences in PGD2 release.

2.5 PAPER III; ABT-737 AND ROSCOVITINE INDUCES APOPTOSIS IN A SYNERGISTIC FASHION IN MAST CELLS CARRYING THE D816V MUTATION

Systemic mastocytosis is characterized by the accumulation of aberrant mast cells with D81V KIT mutation. The D816V KIT mutation renders the receptor to be phosphorylated and the downstream signaling pathways continuously activated. One effect of this autoactivation is the increased expression of the prosurvival members of the Bcl-2 family, a family of proteins which are the main regulators of cell survival (190). In this study we examined the effect of combinatorial treatment of KIT D816V positive mast cells with ABT-737 and Roscovitine. In order to target most of the pro survival Bcl-2 family members. ABT737 is a BH3-mimetic which inhibits Bcl-2, Bcl-XL and Bcl-w. Our group has previously shown that it ABT737 induces apoptosis in cutaneous mast cells (178). Roscovitine is a CDK-inhibitor that also downregulate the expression of prosurvival Mcl-1 (262).

We found that ABT-737 and Roscovitine both alone and in combination induced apoptosis in D816V positive HMC-1.2 mast cells (Figure 8). The cells were treated for 24 and 48 hrs with Roscovitine 10 or 30 μ M, ABT 0.05 μ M or the combination of the two (ROS 10 μ M and ABT 0.05 μ M). The combination of the drugs at suboptimal concentrations induced a marked reduction in cell viability. The combinatorial treatment reduced the expression of Mcl-1 and significantly upregulated the expression of proapoptotic Bim_{EL}.

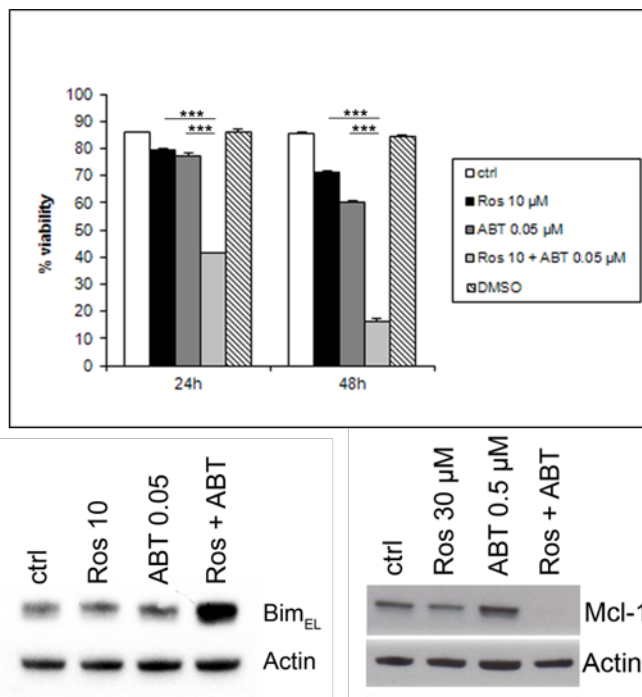

Figure 8. Low doses of ABT-737 and Roscovitine exhibit synergistic effects in inducing mast cell death. HMC-1.2 cells were treated with Roscovitine, ABT-737 or the combination of the two. Survival was measured after 24 and 48 hrs (top); the levels of Bim_{EL} and Mcl-1 were measured after 48 hours (bottom).

In conclusion we demonstrate that the antiapoptotic proteins of the Bcl-2 family are promising targets in the treatment of systemic mastocytosis. By combining the two drugs, in order to target most of the different pro-survival proteins, the doses can be reduced significantly. This would reduce the risk of severe side effects, increase the treatment efficacy and may hinder the development of drug resistance.

2.6 PAPER IV; HISTONE DEACETYLASE INHIBITOR SAHA MEDIATES MAST CELL DEATH AND EPIGENETIC SILENCING OF CONSTITUTIVELY ACTIVE D816V KIT IN SYSTEMIC MASTOCYTOSIS

The aim of this study was to investigate the effect of the histone deacetylase inhibitor SAHA on mast cells with D816V mutation. HDAC inhibitors (HDACi) are small molecules that prevent the enzymatic removal of acetyl groups from the N-terminal tails of histones. SAHA is a pan inhibitor altering the expression of 5-15% of protein coding genes; approximately same number of genes are up and down regulated (263). SAHA is currently approved for the treatment of cutaneous T-cell lymphoma and in addition presently in numerous clinical trials. Previous studies in other cellular systems indicate that the KIT receptor is a promising target of SAHA (264).

In this study we analyzed the effect of SAHA as well as other HDACi Romidepsin, Panobinostat and Valproic acid on the human mast cell line HMC-1.2 which carries the D816V KIT mutation. All four drugs induced apoptosis and reduced cell proliferation in a dose dependent fashion. The most extensive effect was achieved with SAHA treatment. Analysis of KIT receptor expression revealed a decrease in both mRNA levels and surface expression as well as in receptor phosphorylation.

Knowing that the cells die and that the mutated receptor is targeted we continued to investigate the effect on fresh bone-marrow samples from patients with different forms of systemic mastocytosis. SAHA treatment had a profound effect on the bone marrow cells and the efficacy of the drug correlated to the severity of the disease (Figure 9).

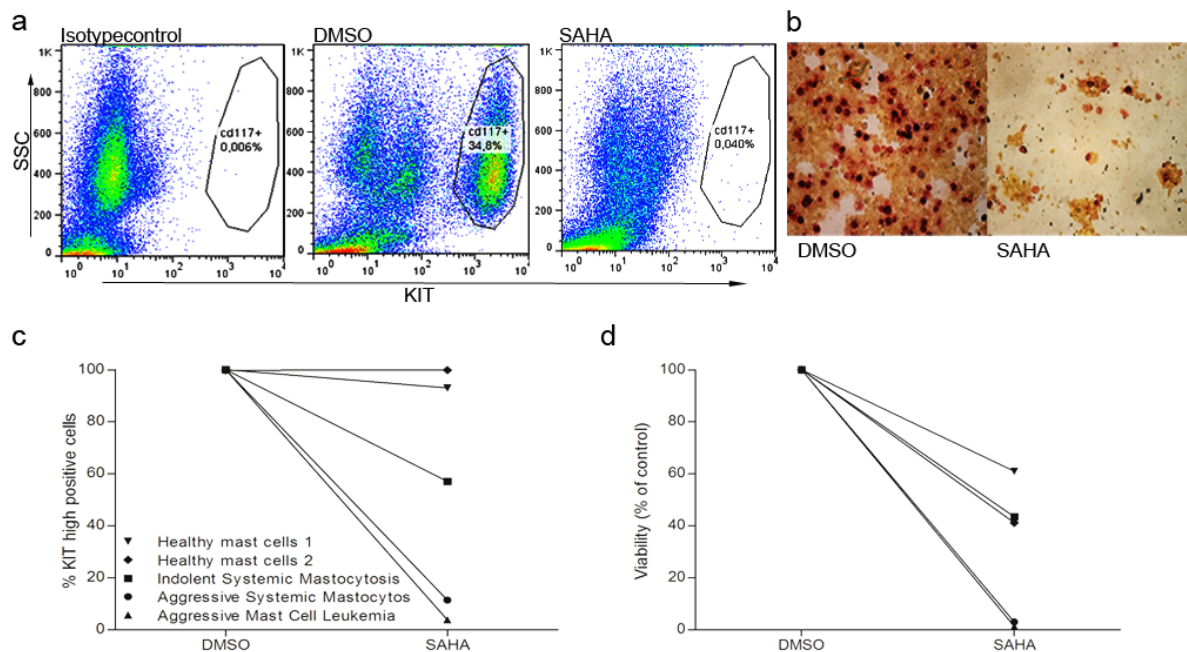

Figure 9. Response to SAHA treatment in mast cells isolated from bone marrow. A) Flow cytometry gating strategy for side scatter (SSC) and KIT expression (CD117), example of gating for CD117 positive cells. B) Staining of patient sample bone marrow mast cells upon incubation with SAHA for 48 h. C) Decrease in surface KIT in patients vs controls D) Mast cell viability after 48h of SAHA treatment.

To further investigate the mechanistic effect we examined the epigenetic stability of the genomic region around the KIT gene, focusing on the regulatory region as well as the genes up (KDR) and downstream (PDGFR α) of KIT. Using the active marks H3K18ac and H3K27ac and repressive marks H3K9me3 and H3K27me3 we could discern that in the KIT mutated cell line HMC-1.2 the KIT region is active already at baseline but the activation was significantly reduced with SAHA treatment ($p < 0.05$ for -71, $p < 0.01$ for -123 and KIT promoter region) (Figure 10). The surrounding genes though were silent at baseline but were activated with SAHA.

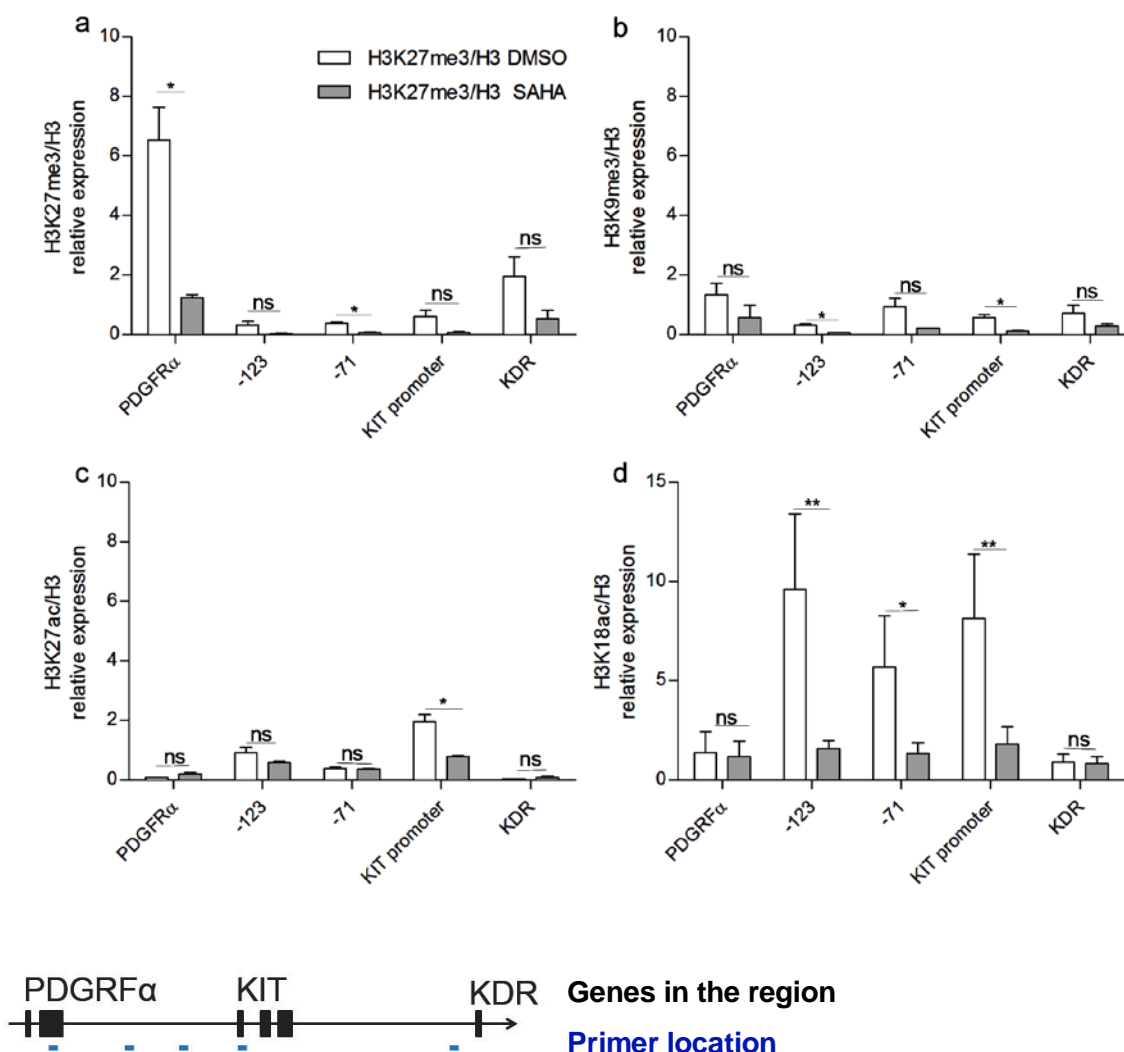

Figure 10. ChIP qPCR of HMC1.2 cells with active and repressive histone H3 marks, corrected for H3 density over the KIT region. A) H3K27me3 repressive mark. B) H3K9me3 repressive mark. C) H3K27ac active mark. D) H3K18ac/H3 active mark. E) Illustration of the region and primers

In this study we show that the HDAC inhibitor SAHA is very effective at inducing apoptosis in aberrant mast cells because the KIT region is silenced at an epigenetic level. The mechanistic need to be further elucidated, but we suggest that SAHA should be considered in the treatment of the more aggressive cases of mastocytosis.

2.7 PAPER V; ANTI-APOPTOTIC BFL-1 IS THE MAJOR EFFECTOR IN ACTIVATION-INDUCED HUMAN MAST CELL SURVIVAL

Mast cells are long lived tissue residing sentinels. In order to keep this function they need the capacity not only to survive the massive cellular rearrangement of degranulation but also to swiftly reform and restock the granules (89). Our group has previously demonstrated that the antiapoptotic protein Bfl-1/A1 is upregulated in activated mast cells and that mouse mast cells lacking the A1 gene do not exhibit activation induced survival (197). In this study we investigated the role of Bfl-1 in human mast cells to decipher if this is the main regulator of activation-induced mast cell survival.

ABT-737 and Roscovitine failed to hinder activation induced survival following IgE cross linking indicating that neither Bcl-2, Bcl-X_L, Bcl-w nor Mcl-1 are major regulators. However by inhibiting the expression of t Bfl-1 using siRNA the mast cells did not exhibit activation-induced survival (Figure 11). To translate these data into an *in vivo* situation we examined the Bfl-1 expression in mast cells. In allergen provoked skin of allergic subjects we found a significant increase in the mast cell expression of Bfl-1 in the allergen challenged skin. Interestingly there was also an increase of Bfl-1 expressing mast cells in lesional skin of patients suffering from atopic dermatitis and psoriasis. Those diseases are not associated with IgE- receptor crosslinking but mast cells can also express IgG-receptor FcγRI and activation through this also induces a similar survival program in mast cells (203).

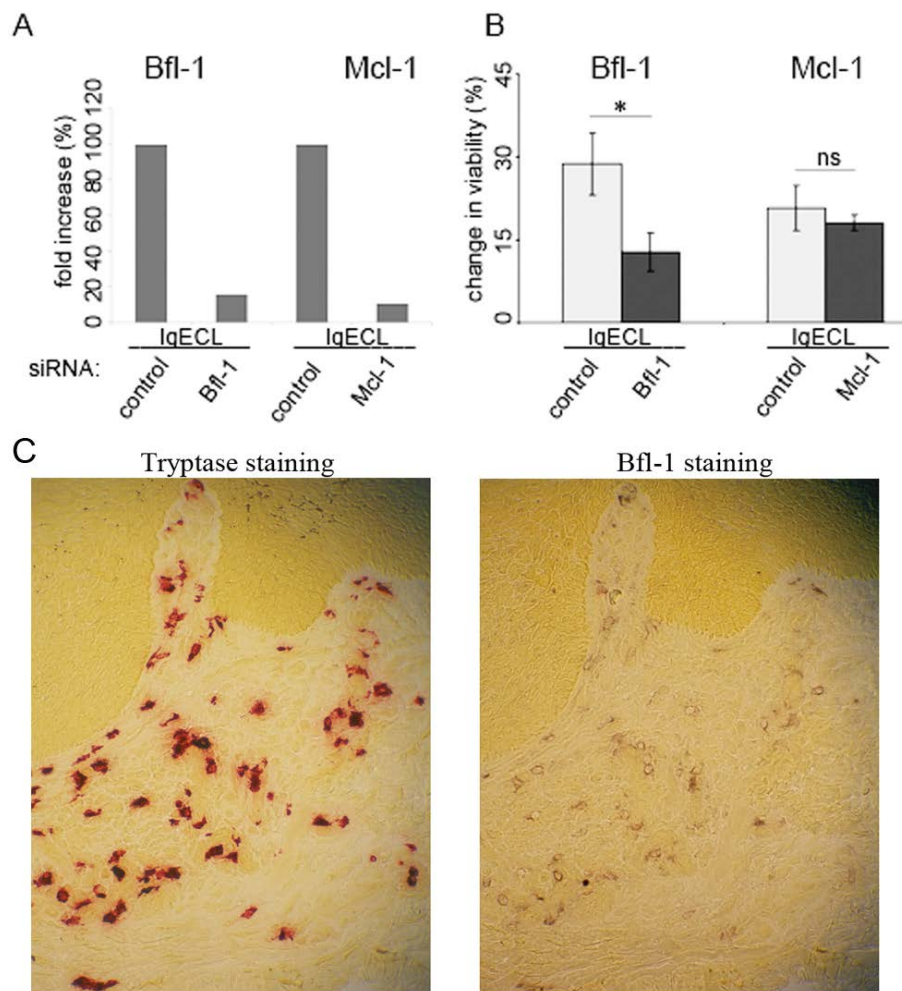

Figure 11, Bfl-1 regulate activation induced survival and is upregulated in atopic skin.

A) siRNA inhibit upregulation of Bfl-1 and Mcl-1. B) Silencing of Bfl-1 inhibit the increase of viability following IgE crosslinking. C) Co-staining of tryptase and Bfl-1 in atopic skin.

In conclusion, in this study we demonstrate that Bfl-1 is the main regulator of activation-induced mast cell survival after IgE-receptor crosslinking. Since there was an increased expression of Bfl-1 in the mast cells in the provoked skin of patients with allergic disease we propose that Bfl-1 can be responsible for the increase in mast cell number and thus can serve as a therapeutic target for some groups of patients with cutaneous inflammatory diseases.

2.8 PAPER VI; KNOCKDOWN OF THE ANTI-APOPTOTIC BCL-2-FAMILY MEMBER A1 PROTECTS MICE FROM SYSTEMIC ANAPHYLAXIS

In this study we continued to investigate the function of A1 in mast cell development and survival, and for mast cell driven reactions *in vivo*. Our previous studies showed that A1/Bfl-1 is an important regulator of mast cell survival however the *in vivo* significance is poorly investigated. Due to the genetic location of the three A1 isoforms no traditional A1 knockout mouse has been possible to create. Ottina et al developed a constitutive knockdown of all A1 isoforms in the hematopoietic system by RNA interference (258).

Mast cells are highly heterogeneous but how the differences are regulated is poorly understood. Murine mast cells are generally divided into mucosal and connective tissue mast cells. They are located at different tissues and express diverse proteases. They are very diverse in their development and survival. Connective tissue mast cells are long lived and tissue resided. Mucosal mast cells are quickly recruited into the tissue after a helminth infection though only survives for a few weeks.

Mucosal like and connective tissue like mast cell were cultured and the RNA interference was stable during the cultivation. The mucosal like mast cells did not appear to depend on A1 for survival and differentiation. The connective tissue like mast cells on the other hand showed impaired mast cell survival after IgE-receptor crosslinking, similarly to previously described (201). The number of connective tissue mast cells *in vivo* were significantly reduced in ears and tongues of A1 knockout mice.

Both passive systemic and cutaneous anaphylaxis was severely reduced in mice lacking A1 expression and there was a significant reduction of mast cells in the dermis of the ear pinnae after passive cutaneous anaphylaxis (Figure 12). In passive cutaneous anaphylaxis DNP-specific IgE was injected into the ear pinnae (WT n=6, VVFF control n=7 and VVA1 n=5), after 24h the mice were challenged by i.v injection of the DNP and ear swelling was investigated every 30 min for 6 hours. After 6 hours the number of mast cells in the ear pinnae was investigated and there were significant differences in mast cell numbers. Interestingly when peritoneal mast cell from A1 knockout mice were cultured *in vitro* we found that they do not proliferate at the same rate as the control samples.

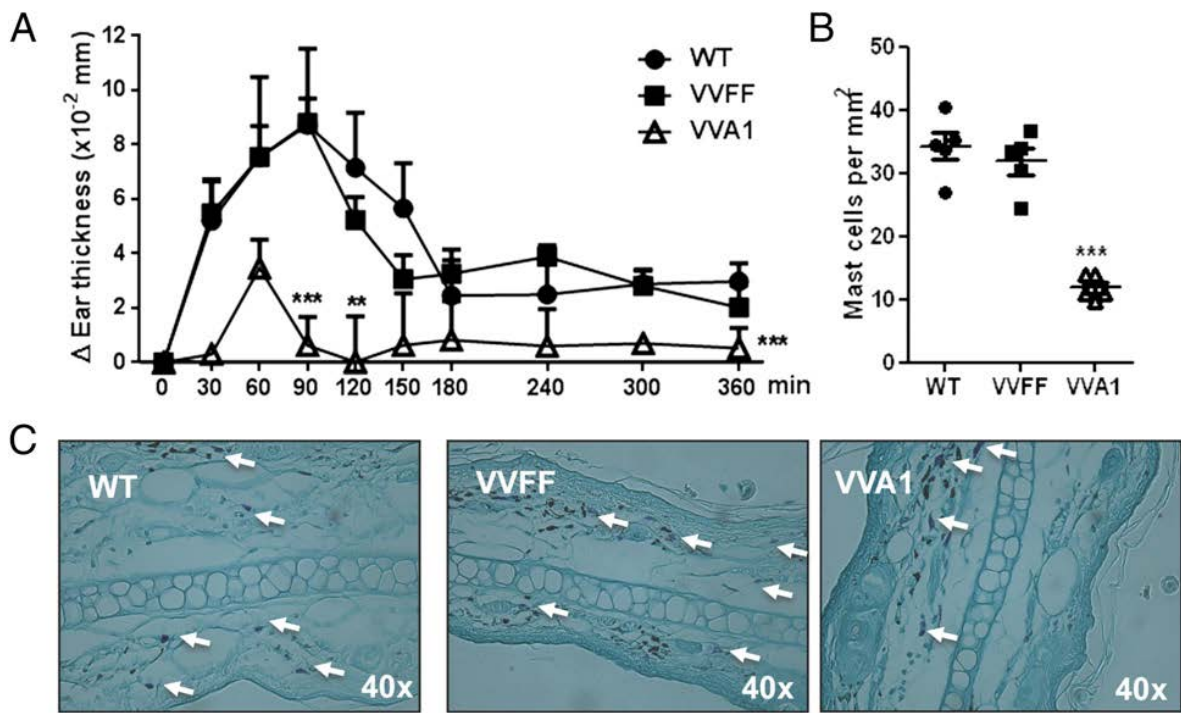

Figure 12. A1-knockdown mice exhibit markedly reduced IgE-dependent cutaneous PCA. A) Passive cutaneous anaphylaxis, ear swelling was measured immediately before and at 30-min intervals after Ag challenges for 6 h. B) Numbers of mast cells in the dermis of ear pinnae at sites of PCA 6 h after DNP challenge. C) Representative toluidine blue staining of activated mast cells in ear pinnae. Arrows indicate mast cells.

Mice which lack A1 expression do not respond to activation of the FcεRI receptor via IgE crosslinking to the same extent as control mice. They also have fewer mast cells in the tissue and interestingly mast cells recovered from the peritoneal cavity display impaired proliferation. To conclude we demonstrate that A1 is an important regulator in the development of connective tissue mast cells an important step in the understanding in mast cell heterogeneity.

3 FUTURE PERSPECTIVE

Though the mast cell was discovered in 1878 there are so many things we do not understand about them. The first hundred years they were mostly regarded as effector cells in allergic diseases. Currently though they are well recognized as an important part of the body's host defense system. In this thesis I describe the work I have done to understand the mechanisms of mastocytosis, identifying a cure and to understand mast cell development and survival. Mastocytosis a rare disease but it is well worth to study. To me one of the most puzzling questioning is exactly how the point mutation develops? Mastocytosis is not a hereditary disease though a few cases of familiar mastocytosis had been described. And most patients with systemic mastocytosis carry the same point mutation though in different compartments. So why this exact locus? What is it with this small genetic region that make different, unrelated people all around the world acquire the same exact mutation? Point mutations generally occur during replication but they can also be the result of DNA damage. Recent studies highlight the correlation between epigenetic changes and DNA mutations. The epigenetic network of DNA and histone modifications modify the DNA accessibility but also the genetic stability. TET2 along with other genes involved in DNA methylation have been shown to be mutated in mastocytosis by many groups. Also the general levels of DNA methylation has been shown to be reduced. We know from other neoplastic diseases that point mutations often occur at CpG sites. For this reason it would be interesting to investigate the epigenome of mast cells from patients with mastocytosis. To backtrack the cells from the mature mast cells back to the progenitor cells and study the DNA for mutations as well as alterations in the DNA stability and histone status. The D816V mutation is a founding event but perhaps the chain starts before that, with a slight shift in DNA stability?

By increasing our understanding of the disease we may find new ways to treat the patients. At the moment different lines of therapies are being investigated; targeting the KIT receptor, inhibiting downstream pathways of KIT, utilizing surface molecules etc. Many of the drugs have severe side effects. Combinational treatments where drugs increase the efficacy by synergistically target parts of the same pathway is a way to reduce the drug dose which should reduce the side effects. For example a TKI could be combined with one or more molecular inhibitors. Within the field of TKI development many new KIT specific drugs are emerging however they have all different effects of the different KIT mutations. In the future of personalized medicine the analysis of the patient mutational status could direct the treatment.

Mast cells are very heterogeneous their development entirely dependent of the release of cytokines from the surrounding tissue. This is a complex event activating multiple pathways and finally producing proteins to execute the receptor signals. Which proteins are expressed is largely depending on the epigenetic landscape of the cell. We have just started to scrape the surface on how mast cell development is regulated by epigenetic changes. Recently Damiani *et al* showed that platelet activating factor alter the expression of DNA methyltransferases 1 and 3b (265). At the same time the expression of histone acetyltransferase increases as do the

H3acetylation. It is probable that similar events occur after activation of other cytokine receptors. Receptor stimulation leads thus to the opening of genes. It would be interesting to investigate how different stimuli alter the epigenetic genome and how that change gene transcription. It would also alter the transcription of noncoding RNAs. The latest study shows that there are almost four thousand miRNAs in the human genome but only a handful of them have been implicated in mast cell biology (266). Even fewer of them have been functionally studied but those investigations prove that miRNAs are vital in mast cell development in health and disease. Long noncoding RNAs (lncRNAs) are ten times longer than miRNAs and by far more numerous about the same numbers as of protein coding genes. They regulate gene transcription at multiple levels and by different mechanisms. For example by actively cooperate in transcriptional complexes and by binding and by inhibiting the mRNA produced however. Only a few lncRNAs have been characterized and studied in detail and next to nothing is known about lncRNAs and mast cells. There are some studies showing lncRNA influencing hematopoiesis by affecting transcription factors like GATA1 and TAL-1 both of which are important in mast cell development. A quick enquiry reveals there are 3 lncRNAs placed in the KIT gene. Their expression and function would be very interesting to investigate.

There are many interesting lines of enquiry in the field of mast cell biology which are worth investigating. However I find that most new breakthroughs come after the development of new methods. Therefore it is hard to imagine what awaits around the corner. The implementation of the CRISPR/Cas9 technique into mast cell research will expose new frontiers. The first studies applying it in mast cell biology revealed the importance of carbonic anhydrase enzymes in mast cell development (267).

4 ACKNOWLEDGEMENTS

I would like to express my genuine appreciation to the people who helped me complete this thesis. I would especially like to thank the following persons:

First of all I want to thank my main supervisor professor **Gunnar Nilsson** for supporting me in all aspects of life and for letting me explore new fields of research without hesitation. My co-supervisors; **Johanna Ungerstedt** for pushing me when needed and **Christine Möller Westerberg** for teaching me mast cell techniques.

To all my co-othorsfor very good collaborations; **Johan Kolmert, Johan Bood, John Öhd, Sven-Erik Dahlén, Barbro Dahlén, Matilda Kjellander, Michel Arock, Maryla Krajewska, Monica Arvidsson, Sabina Rak, John C Reed** and **Ilkka Harvimaweaz**

The members of Mastocytosis center Karolinska. **Theo Gülen, Hans Hägglund, Birgitta Sander** and **Maria Sääf**.

Past and present colleagues of the mast cell group and close collaborators; **Maria** for being such an amazing friend and for teaching me how to work with mice. **Anna** for pointing out the value of honey. **Ying** for being a great travel companion. **Jennine** for taking over the SAHA project. **Elin** for interesting discussions, **Avinash** good luck with the rest of your studies, **Hani** for fantastic times in the lab and on rout, **Caroline** for your constant positivity, **Mikael A** for always giving positive comments. **Agnetha** for all great times in and out of the lab, **Camilla** for sharing quirky stories to keep our mood up at late nights during the MAS project, **Mattias** for great laughs, **Rohit** for always having a kind word, **Choi** for interesting fashion discussion, **Sarah** for always baking something fantastic when it is most needed, **Carolina** for all your good advice, **Malin** for agreeing to have me as your supervisor, **Barbara** for fun talks, **Lisa** for carpooling and **Magdalena** for taking over the miRNA project.

To everyone in the lab in Innsbruck for making me feel so welcome! Special thanks to Professor **Andreas Villunger** for inviting me to your group and **Eleonora Ottina** for being such a good friend and showing me a great time in Innsbruck; fondue, Tango, shopping etc. And please extend my gratitude to your parents for their open welcome of me into their home!

Everybody at L2:04, for making it a really exceptional working environment. Special thanks to the people creating the best office in the world, Versailles; **Carin** for great movie nights and then dragging me to the gym to work the candy, **Thomas** for fun music discussions, **Anna-Maria** for great laughs , **Amanda** for telling fun jokes and **Kiran** for your patient when trying to make me understand the greatness of cricket.

Special thanks to: **Steffie** for great dinners and all your support, **Ann-Laure** for champagne outings and French lunches, **Cindy** for ballet nights, **Anna A** for your warm friendship. **Jonas** for always having a great story to share, **Konrad** for nice parties, **Jeanette** for rescuing

my flowers and fun knitting discussions, **Emelie** for organizing fantastic movie nights and **Pia** for coming to my aid.

Gamla SLU gänget; **Jenny** för att du alltid orkar lyssna och för alla skratt, **Louise** för alla roliga samtal vi haft under x antal timmar i bilen och för att du alltid finns där och **Adam** som inte får blanda några drinkar, **Nicola** för att du körde hem min bil när polisen stoppade mig och **Emilia** för härliga hundpromenader.

Nya och gamla vänner; **Niclas** och **Therese** för alla roliga saker vi gjort ihop och för att ni alltid öppnar ert hem för mig och Sander. **Lotta** som jag träffade på en filt för 36 år sedan och som svarar när jag hör av mig oavsett hur länge det gått sedan vi sist sågs. Och för att du gjort illustrationerna i denna bok.

Mamma **Ingela Däcker** och pappa **Håkan Lyberg** för att ni alltid låtit mig drivas av nyfikenhet och för allt stöd medan jag skriver detta. Utan det hade jag aldrig lyckats avsluta detta.

Till min älskade unge **Alexander** för att du visat mig vad livet egentligen handlar om (och för att du sover när jag skriver detta)

5 REFERENCES

1. Crivellato E, Travan L, & Ribatti D (2015) The phylogenetic profile of mast cells. *Methods in molecular biology* 1220:11-27.
2. Crivellato E, Beltrami C, Mallardi F, & Ribatti D (2003) Paul Ehrlich's doctoral thesis: a milestone in the study of mast cells. *British journal of haematology* 123(1):19-21.
3. Galli SJ, Nakae S, & Tsai M (2005) Mast cells in the development of adaptive immune responses. *Nature immunology* 6(2):135-142.
4. Metz M & Maurer M (2007) Mast cells--key effector cells in immune responses. *Trends in immunology* 28(5):234-241.
5. Cardamone C, Parente R, Feo G, & Triggiani M (2016) Mast cells as effector cells of innate immunity and regulators of adaptive immunity. *Immunology letters* 178:10-14.
6. Gri G, *et al.* (2012) Mast cell: an emerging partner in immune interaction. *Frontiers in immunology* 3:120.
7. Abraham SN & St John AL (2010) Mast cell-orchestrated immunity to pathogens. *Nature reviews. Immunology* 10(6):440-452.
8. Trivedi NH, *et al.* (2013) Mast cells: multitalented facilitators of protection against bacterial pathogens. *Expert review of clinical immunology* 9(2):129-138.
9. Doener F, *et al.* (2013) Mast cell-derived mediators promote murine neutrophil effector functions. *International immunology* 25(10):553-561.
10. Nakae S, Suto H, Berry GJ, & Galli SJ (2007) Mast cell-derived TNF can promote Th17 cell-dependent neutrophil recruitment in ovalbumin-challenged OTII mice. *Blood* 109(9):3640-3648.
11. Echtenacher B, Mannel DN, & Hultner L (1996) Critical protective role of mast cells in a model of acute septic peritonitis. *Nature* 381(6577):75-77.
12. Malaviya R, Ikeda T, Ross E, & Abraham SN (1996) Mast cell modulation of neutrophil influx and bacterial clearance at sites of infection through TNF-alpha. *Nature* 381(6577):77-80.
13. Enoksson M, *et al.* (2011) Mast cells as sensors of cell injury through IL-33 recognition. *Journal of immunology* 186(4):2523-2528.
14. Lunderius-Andersson C, Enoksson M, & Nilsson G (2012) Mast Cells Respond to Cell Injury through the Recognition of IL-33. *Frontiers in immunology* 3:82.
15. Succar J, *et al.* (2014) The role of mouse mast cell proteases in the proliferative phase of wound healing in microdeformational wound therapy. *Plastic and reconstructive surgery* 134(3):459-467.
16. Zhang D, *et al.* (2012) Mast-cell degranulation induced by physical stimuli involves the activation of transient-receptor-potential channel TRPV2. *Physiological research / Academia Scientiarum Bohemoslovaca* 61(1):113-124.
17. Amin K (2012) The role of mast cells in allergic inflammation. *Respiratory medicine* 106(1):9-14.

18. Dahlin JS & Hallgren J (2015) Mast cell progenitors: origin, development and migration to tissues. *Molecular immunology* 63(1):9-17.
19. Abonia JP, *et al.* (2006) Alpha-4 integrins and VCAM-1, but not MAdCAM-1, are essential for recruitment of mast cell progenitors to the inflamed lung. *Blood* 108(5):1588-1594.
20. Ochi H, *et al.* (1999) T helper cell type 2 cytokine-mediated comitogenic responses and CCR3 expression during differentiation of human mast cells in vitro. *The Journal of experimental medicine* 190(2):267-280.
21. Amin K, Janson C, Harvima I, Venge P, & Nilsson G (2005) CC chemokine receptors CCR1 and CCR4 are expressed on airway mast cells in allergic asthma. *The Journal of allergy and clinical immunology* 116(6):1383-1386.
22. Valent P, *et al.* (1992) Induction of differentiation of human mast cells from bone marrow and peripheral blood mononuclear cells by recombinant human stem cell factor/kit-ligand in long-term culture. *Blood* 80(9):2237-2245.
23. Irani AM, *et al.* (1992) Recombinant human stem cell factor stimulates differentiation of mast cells from dispersed human fetal liver cells. *Blood* 80(12):3009-3021.
24. Mitsui H, *et al.* (1993) Development of human mast cells from umbilical cord blood cells by recombinant human and murine c-kit ligand. *Proceedings of the National Academy of Sciences of the United States of America* 90(2):735-739.
25. Kirshenbaum AS, *et al.* (1992) Effect of IL-3 and stem cell factor on the appearance of human basophils and mast cells from CD34+ pluripotent progenitor cells. *Journal of immunology* 148(3):772-777.
26. Lennartsson J & Ronnstrand L (2012) Stem cell factor receptor/c-Kit: from basic science to clinical implications. *Physiological reviews* 92(4):1619-1649.
27. Speiran K, *et al.* (2009) Endogenous suppression of mast cell development and survival by IL-4 and IL-10. *Journal of leukocyte biology* 85(5):826-836.
28. Hu ZQ, Zhao WH, & Shimamura T (2007) Regulation of mast cell development by inflammatory factors. *Current medicinal chemistry* 14(28):3044-3050.
29. Andersson CK, Mori M, Bjermer L, Lofdahl CG, & Erjefalt JS (2009) Novel site-specific mast cell subpopulations in the human lung. *Thorax* 64(4):297-305.
30. Kitamura Y (1989) Heterogeneity of mast cells and phenotypic change between subpopulations. *Annual review of immunology* 7:59-76.
31. Irani AA, Schechter NM, Craig SS, DeBlois G, & Schwartz LB (1986) Two types of human mast cells that have distinct neutral protease compositions. *Proceedings of the National Academy of Sciences of the United States of America* 83(12):4464-4468.
32. Pejler G, Ronnberg E, Waern I, & Wernersson S (2010) Mast cell proteases: multifaceted regulators of inflammatory disease. *Blood* 115(24):4981-4990.
33. Schwartz LB, Irani AM, Roller K, Castells MC, & Schechter NM (1987) Quantitation of histamine, tryptase, and chymase in dispersed human T and TC mast cells. *Journal of immunology* 138(8):2611-2615.
34. Abonia JP, *et al.* (2010) Involvement of mast cells in eosinophilic esophagitis. *The Journal of allergy and clinical immunology* 126(1):140-149.

35. Enerback L (1966) Mast cells in rat gastrointestinal mucosa. I. Effects of fixation. *Acta pathologica et microbiologica Scandinavica* 66(3):289-302.
36. Enerback L (1966) Mast cells in rat gastrointestinal mucosa. 2. Dye-binding and metachromatic properties. *Acta pathologica et microbiologica Scandinavica* 66(3):303-312.
37. Guy-Grand D, Dy M, Luffau G, & Vassalli P (1984) Gut mucosal mast cells. Origin, traffic, and differentiation. *The Journal of experimental medicine* 160(1):12-28.
38. Xing W, Austen KF, Gurish MF, & Jones TG (2011) Protease phenotype of constitutive connective tissue and of induced mucosal mast cells in mice is regulated by the tissue. *Proceedings of the National Academy of Sciences of the United States of America* 108(34):14210-14215.
39. Wernersson S & Pejler G (2014) Mast cell secretory granules: armed for battle. *Nature reviews. Immunology* 14(7):478-494.
40. Dwyer DF, Barrett NA, Austen KF, & Immunological Genome Project C (2016) Expression profiling of constitutive mast cells reveals a unique identity within the immune system. *Nature immunology* 17(7):878-887.
41. Yarden Y, *et al.* (1987) Human proto-oncogene c-kit: a new cell surface receptor tyrosine kinase for an unidentified ligand. *The EMBO journal* 6(11):3341-3351.
42. Caruana G, Cambareri AC, & Ashman LK (1999) Isoforms of c-KIT differ in activation of signalling pathways and transformation of NIH3T3 fibroblasts. *Oncogene* 18(40):5573-5581.
43. Chan EC, *et al.* (2013) KIT GNNK splice variants: expression in systemic mastocytosis and influence on the activating potential of the D816V mutation in mast cells. *Experimental hematology* 41(10):870-881 e872.
44. Fernando H, *et al.* (2006) A conserved quadruplex motif located in a transcription activation site of the human c-kit oncogene. *Biochemistry* 45(25):7854-7860.
45. Roskoski R, Jr. (2005) Structure and regulation of Kit protein-tyrosine kinase--the stem cell factor receptor. *Biochemical and biophysical research communications* 338(3):1307-1315.
46. Sun J, Pedersen M, Bengtsson S, & Ronnstrand L (2007) Grb2 mediates negative regulation of stem cell factor receptor/c-Kit signaling by recruitment of Cbl. *Experimental cell research* 313(18):3935-3942.
47. Kozlowski M, *et al.* (1998) SHP-1 binds and negatively modulates the c-Kit receptor by interaction with tyrosine 569 in the c-Kit juxtamembrane domain. *Molecular and cellular biology* 18(4):2089-2099.
48. Sharma N, *et al.* (2012) SH2 domain-containing phosphatase 2 is a critical regulator of connective tissue mast cell survival and homeostasis in mice. *Molecular and cellular biology* 32(14):2653-2663.
49. Blume-Jensen P, Wernstedt C, Heldin CH, & Ronnstrand L (1995) Identification of the major phosphorylation sites for protein kinase C in kit/stem cell factor receptor in vitro and in intact cells. *The Journal of biological chemistry* 270(23):14192-14200.
50. Zhang Z, *et al.* (2016) A novel slug-containing negative-feedback loop regulates SCF/c-Kit-mediated hematopoietic stem cell self-renewal. *Leukemia*.

51. Babina M, *et al.* (2006) Baseline and stimulated turnover of cell surface c-Kit expression in different types of human mast cells. *Experimental dermatology* 15(7):530-537.
52. Leever SJ, Vanhaesebroeck B, & Waterfield MD (1999) Signalling through phosphoinositide 3-kinases: the lipids take centre stage. *Current opinion in cell biology* 11(2):219-225.
53. Serve H, *et al.* (1995) Differential roles of PI3-kinase and Kit tyrosine 821 in Kit receptor-mediated proliferation, survival and cell adhesion in mast cells. *The EMBO journal* 14(3):473-483.
54. Blume-Jensen P, Janknecht R, & Hunter T (1998) The kit receptor promotes cell survival via activation of PI 3-kinase and subsequent Akt-mediated phosphorylation of Bad on Ser136. *Current biology : CB* 8(13):779-782.
55. Wick MJ, Dong LQ, Riojas RA, Ramos FJ, & Liu F (2000) Mechanism of phosphorylation of protein kinase B/Akt by a constitutively active 3-phosphoinositide-dependent protein kinase-1. *The Journal of biological chemistry* 275(51):40400-40406.
56. Raught B, Gingras AC, & Sonenberg N (2001) The target of rapamycin (TOR) proteins. *Proceedings of the National Academy of Sciences of the United States of America* 98(13):7037-7044.
57. Moller C, *et al.* (2005) Stem cell factor promotes mast cell survival via inactivation of FOXO3a-mediated transcriptional induction and MEK-regulated phosphorylation of the proapoptotic protein Bim. *Blood* 106(4):1330-1336.
58. Gardai SJ, *et al.* (2004) Phosphorylation of Bax Ser184 by Akt regulates its activity and apoptosis in neutrophils. *The Journal of biological chemistry* 279(20):21085-21095.
59. Datta SR, *et al.* (1997) Akt phosphorylation of BAD couples survival signals to the cell-intrinsic death machinery. *Cell* 91(2):231-241.
60. Ong CJ, *et al.* (2007) Small-molecule agonists of SHIP1 inhibit the phosphoinositide 3-kinase pathway in hematopoietic cells. *Blood* 110(6):1942-1949.
61. Mondal S, Subramanian KK, Sakai J, Bajrami B, & Luo HR (2012) Phosphoinositide lipid phosphatase SHIP1 and PTEN coordinate to regulate cell migration and adhesion. *Molecular biology of the cell* 23(7):1219-1230.
62. Linnekin D, *et al.* (1996) JAK2 is constitutively associated with c-Kit and is phosphorylated in response to stem cell factor. *Acta haematologica* 95(3-4):224-228.
63. Morales JK, Falanga YT, Depcrynski A, Fernando J, & Ryan JJ (2010) Mast cell homeostasis and the JAK-STAT pathway. *Genes and immunity* 11(8):599-608.
64. Gesbert F & Griffin JD (2000) Bcr/Abl activates transcription of the Bcl-X gene through STAT5. *Blood* 96(6):2269-2276.
65. Li Y, Qi X, Liu B, & Huang H (2015) The STAT5-GATA2 pathway is critical in basophil and mast cell differentiation and maintenance. *Journal of immunology* 194(9):4328-4338.
66. Rigacci S, Talini D, & Berti A (2003) LMW-PTP associates and dephosphorylates STAT5 interacting with its C-terminal domain. *Biochemical and biophysical research communications* 312(2):360-366.

67. Croker BA, Kiu H, & Nicholson SE (2008) SOCS regulation of the JAK/STAT signalling pathway. *Seminars in cell & developmental biology* 19(4):414-422.
68. Shuai K (2006) Regulation of cytokine signaling pathways by PIAS proteins. *Cell research* 16(2):196-202.
69. Wandzioch E, Edling CE, Palmer RH, Carlsson L, & Hallberg B (2004) Activation of the MAP kinase pathway by c-Kit is PI-3 kinase dependent in hematopoietic progenitor/stem cell lines. *Blood* 104(1):51-57.
70. Christensen SM, *et al.* (2016) One-way membrane trafficking of SOS in receptor-triggered Ras activation. *Nature structural & molecular biology* 23(9):838-846.
71. Cseh B, Doma E, & Baccarini M (2014) "RAF" neighborhood: protein-protein interaction in the Raf/Mek/Erk pathway. *FEBS letters* 588(15):2398-2406.
72. Yoon S & Seger R (2006) The extracellular signal-regulated kinase: multiple substrates regulate diverse cellular functions. *Growth factors* 24(1):21-44.
73. Linnekin D, DeBerry CS, & Mou S (1997) Lyn associates with the juxtamembrane region of c-Kit and is activated by stem cell factor in hematopoietic cell lines and normal progenitor cells. *The Journal of biological chemistry* 272(43):27450-27455.
74. Samayawardhena LA, Hu J, Stein PL, & Craig AW (2006) Fyn kinase acts upstream of Shp2 and p38 mitogen-activated protein kinase to promote chemotaxis of mast cells towards stem cell factor. *Cellular signalling* 18(9):1447-1454.
75. Sun J, Pedersen M, & Ronnstrand L (2009) The D816V mutation of c-Kit circumvents a requirement for Src family kinases in c-Kit signal transduction. *The Journal of biological chemistry* 284(17):11039-11047.
76. Draber P, Sulimenko V, & Draberova E (2012) Cytoskeleton in mast cell signaling. *Frontiers in immunology* 3:130.
77. Sulimenko V, *et al.* (2006) Regulation of microtubule formation in activated mast cells by complexes of gamma-tubulin with Fyn and Syk kinases. *Journal of immunology* 176(12):7243-7253.
78. Nishida K, *et al.* (2005) Fc{epsilon}RI-mediated mast cell degranulation requires calcium-independent microtubule-dependent translocation of granules to the plasma membrane. *The Journal of cell biology* 170(1):115-126.
79. Lorentz A, Baumann A, Vitte J, & Blank U (2012) The SNARE Machinery in Mast Cell Secretion. *Frontiers in immunology* 3:143.
80. Fonteh AN, Samet JM, & Chilton FH (1995) Regulation of arachidonic acid, eicosanoid, and phospholipase A2 levels in murine mast cells by recombinant stem cell factor. *The Journal of clinical investigation* 96(3):1432-1439.
81. Lewis RA, *et al.* (1982) Prostaglandin D2 generation after activation of rat and human mast cells with anti-IgE. *Journal of immunology* 129(4):1627-1631.
82. Reid G, *et al.* (2003) The human multidrug resistance protein MRP4 functions as a prostaglandin efflux transporter and is inhibited by nonsteroidal antiinflammatory drugs. *Proceedings of the National Academy of Sciences of the United States of America* 100(16):9244-9249.

83. Samuelsson B, Dahlen SE, Lindgren JA, Rouzer CA, & Serhan CN (1987) Leukotrienes and lipoxins: structures, biosynthesis, and biological effects. *Science* 237(4819):1171-1176.
84. Bradding P, *et al.* (1994) Interleukin-4, -5, and -6 and tumor necrosis factor-alpha in normal and asthmatic airways: evidence for the human mast cell as a source of these cytokines. *American journal of respiratory cell and molecular biology* 10(5):471-480.
85. Gordon JR & Galli SJ (1990) Mast cells as a source of both preformed and immunologically inducible TNF-alpha/cachectin. *Nature* 346(6281):274-276.
86. Turner H & Kinet JP (1999) Signalling through the high-affinity IgE receptor Fc epsilonRI. *Nature* 402(6760 Suppl):B24-30.
87. Nadler MJ, Matthews SA, Turner H, & Kinet JP (2000) Signal transduction by the high-affinity immunoglobulin E receptor Fc epsilon RI: coupling form to function. *Advances in immunology* 76:325-355.
88. Draber P, Halova I, Levi-Schaffer F, & Draberova L (2011) Transmembrane adaptor proteins in the high-affinity IgE receptor signaling. *Frontiers in immunology* 2:95.
89. Xiang Z, Block M, Lofman C, & Nilsson G (2001) IgE-mediated mast cell degranulation and recovery monitored by time-lapse photography. *The Journal of allergy and clinical immunology* 108(1):116-121.
90. Schayer RW (1963) Histidine decarboxylase in mast cells. *Annals of the New York Academy of Sciences* 103:164-178.
91. Strasser A, Wittmann HJ, Buschauer A, Schneider EH, & Seifert R (2013) Species-dependent activities of G-protein-coupled receptor ligands: lessons from histamine receptor orthologs. *Trends in pharmacological sciences* 34(1):13-32.
92. Sakai K, Ren S, & Schwartz LB (1996) A novel heparin-dependent processing pathway for human tryptase. Autocatalysis followed by activation with dipeptidyl peptidase I. *The Journal of clinical investigation* 97(4):988-995.
93. Harris JL, *et al.* (2001) Definition of the extended substrate specificity determinants for beta-tryptases I and II. *The Journal of biological chemistry* 276(37):34941-34947.
94. Kawabata A & Kuroda R (2000) Protease-activated receptor (PAR), a novel family of G protein-coupled seven trans-membrane domain receptors: activation mechanisms and physiological roles. *Japanese journal of pharmacology* 82(3):171-174.
95. Gecse K, *et al.* (2008) Increased faecal serine protease activity in diarrhoeic IBS patients: a colonic luminal factor impairing colonic permeability and sensitivity. *Gut* 57(5):591-599.
96. Rubinstein I, Nadel JA, Graf PD, & Caughey GH (1990) Mast cell chymase potentiates histamine-induced wheal formation in the skin of ragweed-allergic dogs. *The Journal of clinical investigation* 86(2):555-559.
97. Roy A, *et al.* (2014) Mast cell chymase degrades the alarmins heat shock protein 70, biglycan, HMGB1, and interleukin-33 (IL-33) and limits danger-induced inflammation. *The Journal of biological chemistry* 289(1):237-250.
98. Waern I, Lundquist A, Pejler G, & Wernersson S (2013) Mast cell chymase modulates IL-33 levels and controls allergic sensitization in dust-mite induced airway inflammation. *Mucosal immunology* 6(5):911-920.

99. Tchougounova E, *et al.* (2005) A key role for mast cell chymase in the activation of pro-matrix metalloprotease-9 and pro-matrix metalloprotease-2. *The Journal of biological chemistry* 280(10):9291-9296.
100. Everitt MT & Neurath H (1980) Rat peritoneal mast cell carboxypeptidase: localization, purification, and enzymatic properties. *FEBS letters* 110(2):292-296.
101. Simons FE, *et al.* (2007) Risk assessment in anaphylaxis: current and future approaches. *The Journal of allergy and clinical immunology* 120(1 Suppl):S2-24.
102. Isidoro-Garcia M, *et al.* (2011) PTGDR gene in asthma: a functional, genetic, and epigenetic study. *Allergy* 66(12):1553-1562.
103. Hirai H, *et al.* (2001) Prostaglandin D2 selectively induces chemotaxis in T helper type 2 cells, eosinophils, and basophils via seven-transmembrane receptor CRTH2. *The Journal of experimental medicine* 193(2):255-261.
104. Xue L, *et al.* (2005) Prostaglandin D2 causes preferential induction of proinflammatory Th2 cytokine production through an action on chemoattractant receptor-like molecule expressed on Th2 cells. *Journal of immunology* 175(10):6531-6536.
105. Mjosberg JM, *et al.* (2011) Human IL-25- and IL-33-responsive type 2 innate lymphoid cells are defined by expression of CRTH2 and CD161. *Nature immunology* 12(11):1055-1062.
106. Theoharides TC, Valent P, & Akin C (2015) Mast Cells, Mastocytosis, and Related Disorders. *The New England journal of medicine* 373(19):1885-1886.
107. Gulen T, Hagglund H, Dahlen B, & Nilsson G (2016) Mastocytosis: the puzzling clinical spectrum and challenging diagnostic aspects of an enigmatic disease. *Journal of internal medicine* 279(3):211-228.
108. Broesby-Olsen S, *et al.* (2016) Multidisciplinary Management of Mastocytosis: Nordic Expert Group Consensus. *Acta dermato-venereologica* 96(5):602-612.
109. Lasho T, *et al.* (2016) Concurrent activating KIT mutations in systemic mastocytosis. *British journal of haematology* 173(1):153-156.
110. Arock M, Akin C, Hermine O, & Valent P (2015) Current treatment options in patients with mastocytosis: status in 2015 and future perspectives. *European journal of haematology* 94(6):474-490.
111. Kanakura Y, *et al.* (1994) Activating mutations of the c-kit proto-oncogene in a human mast cell leukemia cell line. *Leukemia* 8 Suppl 1:S18-22.
112. Nagata H, *et al.* (1995) Identification of a point mutation in the catalytic domain of the protooncogene c-kit in peripheral blood mononuclear cells of patients who have mastocytosis with an associated hematologic disorder. *Proceedings of the National Academy of Sciences of the United States of America* 92(23):10560-10564.
113. Kitayama H, *et al.* (1995) Constitutively activating mutations of c-kit receptor tyrosine kinase confer factor-independent growth and tumorigenicity of factor-dependent hematopoietic cell lines. *Blood* 85(3):790-798.
114. Tang X, *et al.* (2004) A germline mutation in KIT in familial diffuse cutaneous mastocytosis. *Journal of medical genetics* 41(6):e88.

115. Bodemer C, *et al.* (2010) Pediatric mastocytosis is a clonal disease associated with D816V and other activating c-KIT mutations. *The Journal of investigative dermatology* 130(3):804-815.
116. Longley BJ, Jr., *et al.* (1999) Activating and dominant inactivating c-KIT catalytic domain mutations in distinct clinical forms of human mastocytosis. *Proceedings of the National Academy of Sciences of the United States of America* 96(4):1609-1614.
117. Akin C, *et al.* (2004) A novel form of mastocytosis associated with a transmembrane c-kit mutation and response to imatinib. *Blood* 103(8):3222-3225.
118. Georgin-Lavialle S, *et al.* (2012) Mast cell leukemia: identification of a new c-Kit mutation, dup(501-502), and response to masitinib, a c-Kit tyrosine kinase inhibitor. *European journal of haematology* 89(1):47-52.
119. Furitsu T, *et al.* (1993) Identification of mutations in the coding sequence of the proto-oncogene c-kit in a human mast cell leukemia cell line causing ligand-independent activation of c-kit product. *The Journal of clinical investigation* 92(4):1736-1744.
120. Nakagomi N & Hirota S (2007) Juxtamembrane-type c-kit gene mutation found in aggressive systemic mastocytosis induces imatinib-resistant constitutive KIT activation. *Laboratory investigation; a journal of technical methods and pathology* 87(4):365-371.
121. Pignon JM, *et al.* (1997) A new c-kit mutation in a case of aggressive mast cell disease. *British journal of haematology* 96(2):374-376.
122. Garcia-Montero AC, *et al.* (2006) KIT mutation in mast cells and other bone marrow hematopoietic cell lineages in systemic mast cell disorders: a prospective study of the Spanish Network on Mastocytosis (REMA) in a series of 113 patients. *Blood* 108(7):2366-2372.
123. Wasag B, *et al.* (2011) Novel, activating KIT-N822I mutation in familial cutaneous mastocytosis. *Experimental hematology* 39(8):859-865 e852.
124. Molderings GJ, Haenisch B, Bogdanow M, Fimmers R, & Nothen MM (2013) Familial occurrence of systemic mast cell activation disease. *PloS one* 8(9):e76241.
125. Gulen T, Hagglund H, Dahlen B, & Nilsson G (2014) High prevalence of anaphylaxis in patients with systemic mastocytosis - a single-centre experience. *Clinical and experimental allergy : journal of the British Society for Allergy and Clinical Immunology* 44(1):121-129.
126. Alvarez-Twose I, *et al.* (2013) Systemic mastocytosis as a risk factor for severe Hymenoptera sting-induced anaphylaxis. *The Journal of allergy and clinical immunology* 131(2):614-615.
127. van Anrooij B, *et al.* (2013) Higher mast cell load decreases the risk of Hymenoptera venom-induced anaphylaxis in patients with mastocytosis. *The Journal of allergy and clinical immunology* 132(1):125-130.
128. Hartmann K, *et al.* (2016) Cutaneous manifestations in patients with mastocytosis: Consensus report of the European Competence Network on Mastocytosis; the American Academy of Allergy, Asthma & Immunology; and the European Academy of Allergology and Clinical Immunology. *The Journal of allergy and clinical immunology* 137(1):35-45.

129. Valent P, *et al.* (2001) Diagnostic criteria and classification of mastocytosis: a consensus proposal. *Leukemia research* 25(7):603-625.
130. Hartmann K & Metcalfe DD (2000) Pediatric mastocytosis. *Hematology/oncology clinics of North America* 14(3):625-640.
131. Carter MC, *et al.* (2015) Assessment of clinical findings, tryptase levels, and bone marrow histopathology in the management of pediatric mastocytosis. *The Journal of allergy and clinical immunology* 136(6):1673-1679 e1671-1673.
132. Wiechers T, *et al.* (2015) Large maculopapular cutaneous lesions are associated with favorable outcome in childhood-onset mastocytosis. *The Journal of allergy and clinical immunology* 136(6):1581-1590 e1581-1583.
133. Lange M, *et al.* (2012) Diffuse cutaneous mastocytosis: analysis of 10 cases and a brief review of the literature. *Journal of the European Academy of Dermatology and Venereology : JEADV* 26(12):1565-1571.
134. Hannaford R & Rogers M (2001) Presentation of cutaneous mastocytosis in 173 children. *The Australasian journal of dermatology* 42(1):15-21.
135. Lim KH, *et al.* (2009) Systemic mastocytosis in 342 consecutive adults: survival studies and prognostic factors. *Blood* 113(23):5727-5736.
136. Garcia-Montero AC, *et al.* (2016) KIT D816V-mutated bone marrow mesenchymal stem cells in indolent systemic mastocytosis are associated with disease progression. *Blood* 127(6):761-768.
137. Mayado A, *et al.* (2016) Increased IL6 plasma levels in indolent systemic mastocytosis patients are associated with high risk of disease progression. *Leukemia* 30(1):124-130.
138. Wang SA, *et al.* (2013) Systemic mastocytosis with associated clonal hematological non-mast cell lineage disease: clinical significance and comparison of chromosomal abnormalities in SM and AHNMD components. *American journal of hematology* 88(3):219-224.
139. Travis WD, Li CY, Yam LT, Bergstralh EJ, & Swee RG (1988) Significance of systemic mast cell disease with associated hematologic disorders. *Cancer* 62(5):965-972.
140. Frederiksen JK, Shao L, Bixby DL, & Ross CW (2016) Shared clonal cytogenetic abnormalities in aberrant mast cells and leukemic myeloid blasts detected by single nucleotide polymorphism microarray-based whole-genome scanning. *Genes, chromosomes & cancer* 55(4):389-396.
141. Jawhar M, *et al.* (2015) Molecular profiling of myeloid progenitor cells in multi-mutated advanced systemic mastocytosis identifies KIT D816V as a distinct and late event. *Leukemia* 29(5):1115-1122.
142. Jawhar M, *et al.* (2016) Additional mutations in SRSF2, ASXL1 and/or RUNX1 identify a high-risk group of patients with KIT D816V(+) advanced systemic mastocytosis. *Leukemia* 30(1):136-143.
143. Valent P, *et al.* (2003) Aggressive systemic mastocytosis and related mast cell disorders: current treatment options and proposed response criteria. *Leukemia research* 27(7):635-641.

144. Valent P, *et al.* (2014) Refined diagnostic criteria and classification of mast cell leukemia (MCL) and myelomastocytic leukemia (MML): a consensus proposal. *Annals of oncology : official journal of the European Society for Medical Oncology / ESMO* 25(9):1691-1700.
145. Georgin-Lavialle S, *et al.* (2013) Mast cell leukemia. *Blood* 121(8):1285-1295.
146. Ryan RJ, *et al.* (2013) Mast cell sarcoma: a rare and potentially under-recognized diagnostic entity with specific therapeutic implications. *Modern pathology : an official journal of the United States and Canadian Academy of Pathology, Inc* 26(4):533-543.
147. Monnier J, *et al.* (2016) Mast cell sarcoma: new cases and literature review. *Oncotarget*.
148. Pardanani A (2015) Systemic mastocytosis in adults: 2015 update on diagnosis, risk stratification, and management. *American journal of hematology* 90(3):250-262.
149. Gasior-Chrzan B & Falk ES (1992) Systemic mastocytosis treated with histamine H1 and H2 receptor antagonists. *Dermatology* 184(2):149-152.
150. Nurmatov UB, Rhatigan E, Simons FE, & Sheikh A (2015) H1-antihistamines for primary mast cell activation syndromes: a systematic review. *Allergy* 70(9):1052-1061.
151. Prignano F, Troiano M, & Lotti T (2010) Cutaneous mastocytosis: successful treatment with narrowband ultraviolet B phototherapy. *Clinical and experimental dermatology* 35(8):914-915.
152. Edwards AM & Hagberg H (2010) Oral and inhaled sodium cromoglicate in the management of systemic mastocytosis: a case report. *Journal of medical case reports* 4:193.
153. Soter NA, Austen KF, & Wasserman SI (1979) Oral disodium cromoglycate in the treatment of systemic mastocytosis. *The New England journal of medicine* 301(9):465-469.
154. Turner PJ, Kemp AS, Rogers M, & Mehr S (2012) Refractory symptoms successfully treated with leukotriene inhibition in a child with systemic mastocytosis. *Pediatric dermatology* 29(2):222-223.
155. Siebenhaar F, Akin C, Bindslev-Jensen C, Maurer M, & Broesby-Olsen S (2014) Treatment strategies in mastocytosis. *Immunology and allergy clinics of North America* 34(2):433-447.
156. Douglass JA, *et al.* (2010) Omalizumab is effective in treating systemic mastocytosis in a nonatopic patient. *Allergy* 65(7):926-927.
157. Kluin-Nelemans HC, *et al.* (1992) Response to interferon alfa-2b in a patient with systemic mastocytosis. *The New England journal of medicine* 326(9):619-623.
158. Tefferi A, Li CY, Butterfield JH, & Hoagland HC (2001) Treatment of systemic mast-cell disease with cladribine. *The New England journal of medicine* 344(4):307-309.
159. Ustun C, *et al.* (2014) Hematopoietic stem-cell transplantation for advanced systemic mastocytosis. *Journal of clinical oncology : official journal of the American Society of Clinical Oncology* 32(29):3264-3274.

160. Ma Y, *et al.* (2002) The c-KIT mutation causing human mastocytosis is resistant to STI571 and other KIT kinase inhibitors; kinases with enzymatic site mutations show different inhibitor sensitivity profiles than wild-type kinases and those with regulatory-type mutations. *Blood* 99(5):1741-1744.
161. Growney JD, *et al.* (2005) Activation mutations of human c-KIT resistant to imatinib mesylate are sensitive to the tyrosine kinase inhibitor PKC412. *Blood* 106(2):721-724.
162. Gotlib J, *et al.* (2016) Efficacy and Safety of Midostaurin in Advanced Systemic Mastocytosis. *The New England journal of medicine* 374(26):2530-2541.
163. Chandesris MO, *et al.* (2016) Midostaurin in Advanced Systemic Mastocytosis. *The New England journal of medicine* 374(26):2605-2607.
164. Shah NP, *et al.* (2006) Dasatinib (BMS-354825) inhibits KITD816V, an imatinib-resistant activating mutation that triggers neoplastic growth in most patients with systemic mastocytosis. *Blood* 108(1):286-291.
165. Verstovsek S, *et al.* (2008) Phase II study of dasatinib in Philadelphia chromosome-negative acute and chronic myeloid diseases, including systemic mastocytosis. *Clinical cancer research : an official journal of the American Association for Cancer Research* 14(12):3906-3915.
166. Shi X, *et al.* (2016) Distinct cellular properties of oncogenic KIT receptor tyrosine kinase mutants enable alternative courses of cancer cell inhibition. *Proceedings of the National Academy of Sciences of the United States of America* 113(33):E4784-4793.
167. Dowse R, *et al.* (2016) Beneficial effects of JAK inhibitor therapy in Systemic Mastocytosis. *British journal of haematology*.
168. Yacoub A & Prochaska L (2016) Ruxolitinib improves symptoms and quality of life in a patient with systemic mastocytosis. *Biomarker research* 4:2.
169. Shivakrupa R, Bernstein A, Watring N, & Linnekin D (2003) Phosphatidylinositol 3'-kinase is required for growth of mast cells expressing the kit catalytic domain mutant. *Cancer research* 63(15):4412-4419.
170. Brown JR, *et al.* (2014) Idelalisib, an inhibitor of phosphatidylinositol 3-kinase p110delta, for relapsed/refractory chronic lymphocytic leukemia. *Blood* 123(22):3390-3397.
171. Ma P, *et al.* (2012) Role of intracellular tyrosines in activating KIT-induced myeloproliferative disease. *Leukemia* 26(7):1499-1506.
172. Smrz D, *et al.* (2011) mTORC1 and mTORC2 differentially regulate homeostasis of neoplastic and non-neoplastic human mast cells. *Blood* 118(26):6803-6813.
173. Gabillot-Carre M, *et al.* (2006) Rapamycin inhibits growth and survival of D816V-mutated c-kit mast cells. *Blood* 108(3):1065-1072.
174. Parikh SA, Kantarjian HM, Richie MA, Cortes JE, & Verstovsek S (2010) Experience with everolimus (RAD001), an oral mammalian target of rapamycin inhibitor, in patients with systemic mastocytosis. *Leukemia & lymphoma* 51(2):269-274.
175. Blatt K, *et al.* (2012) The PI3-kinase/mTOR-targeting drug NVP-BEZ235 inhibits growth and IgE-dependent activation of human mast cells and basophils. *PLoS one* 7(1):e29925.

176. Buet D, *et al.* (2012) Cotargeting signaling pathways driving survival and cell cycle circumvents resistance to Kit inhibitors in leukemia. *Blood* 119(18):4228-4241.
177. Nitulescu GM, *et al.* (2016) Akt inhibitors in cancer treatment: The long journey from drug discovery to clinical use (Review). *International journal of oncology* 48(3):869-885.
178. Karlberg M, *et al.* (2010) The BH3-mimetic ABT-737 induces mast cell apoptosis in vitro and in vivo: potential for therapeutics. *Journal of immunology* 185(4):2555-2562.
179. Pardanani A, *et al.* (2015) Aberrant expression of CD123 (interleukin-3 receptor-alpha) on neoplastic mast cells. *Leukemia* 29(7):1605-1608.
180. Frolova O, *et al.* (2014) SL-401 and SL-501, targeted therapeutics directed at the interleukin-3 receptor, inhibit the growth of leukaemic cells and stem cells in advanced phase chronic myeloid leukaemia. *British journal of haematology* 166(6):862-874.
181. Borate U, *et al.* (2016) Treatment of CD30-positive systemic mastocytosis with brentuximab vedotin. *Leukemia research* 44:25-31.
182. Morgado JM, *et al.* (2013) CD30 expression by bone marrow mast cells from different diagnostic variants of systemic mastocytosis. *Histopathology* 63(6):780-787.
183. Senter PD & Sievers EL (2012) The discovery and development of brentuximab vedotin for use in relapsed Hodgkin lymphoma and systemic anaplastic large cell lymphoma. *Nature biotechnology* 30(7):631-637.
184. Hoermann G, *et al.* (2014) CD52 is a molecular target in advanced systemic mastocytosis. *FASEB journal : official publication of the Federation of American Societies for Experimental Biology* 28(8):3540-3551.
185. Vaux DL, Cory S, & Adams JM (1988) Bcl-2 gene promotes haemopoietic cell survival and cooperates with c-myc to immortalize pre-B cells. *Nature* 335(6189):440-442.
186. Czabotar PE, Lessene G, Strasser A, & Adams JM (2014) Control of apoptosis by the BCL-2 protein family: implications for physiology and therapy. *Nature reviews. Molecular cell biology* 15(1):49-63.
187. Hausmann G, *et al.* (2000) Pro-apoptotic apoptosis protease-activating factor 1 (Apaf-1) has a cytoplasmic localization distinct from Bcl-2 or Bcl-x(L). *The Journal of cell biology* 149(3):623-634.
188. Janicke RU, Sprengart ML, Wati MR, & Porter AG (1998) Caspase-3 is required for DNA fragmentation and morphological changes associated with apoptosis. *The Journal of biological chemistry* 273(16):9357-9360.
189. Shin S, *et al.* (2001) An anti-apoptotic protein human survivin is a direct inhibitor of caspase-3 and -7. *Biochemistry* 40(4):1117-1123.
190. Mekori YA, Gilfillan AM, Akin C, Hartmann K, & Metcalfe DD (2001) Human mast cell apoptosis is regulated through Bcl-2 and Bcl-XL. *Journal of clinical immunology* 21(3):171-174.
191. Moller C, *et al.* (2007) Bcl-2 and Bcl-XL are indispensable for the late phase of mast cell development from mouse embryonic stem cells. *Experimental hematology* 35(3):385-393.

192. Maurer M, *et al.* (2000) A role for Bax in the regulation of apoptosis in mouse mast cells. *The Journal of investigative dermatology* 114(6):1205-1206.
193. Ekoff M, *et al.* (2007) The BH3-only protein Puma plays an essential role in cytokine deprivation induced apoptosis of mast cells. *Blood* 110(9):3209-3217.
194. Karlberg M, *et al.* (2010) Pro-apoptotic Bax is the major and Bak an auxiliary effector in cytokine deprivation-induced mast cell apoptosis. *Cell death & disease* 1:e43.
195. Hartmann K, *et al.* (2003) Expression of Bcl-2 and Bcl-xL in cutaneous and bone marrow lesions of mastocytosis. *The American journal of pathology* 163(3):819-826.
196. Jordan JH, *et al.* (2001) Immunohistochemical properties of bone marrow mast cells in systemic mastocytosis: evidence for expression of CD2, CD117/Kit, and bcl-x(L). *Human pathology* 32(5):545-552.
197. Xiang Z, *et al.* (2001) Essential role of the prosurvival bcl-2 homologue A1 in mast cell survival after allergic activation. *The Journal of experimental medicine* 194(11):1561-1569.
198. Alfredsson J, Moller C, & Nilsson G (2006) IgE-receptor activation of mast cells regulates phosphorylation and expression of forkhead and Bcl-2 family members. *Scandinavian journal of immunology* 63(1):1-6.
199. Ottina E, Lyberg K, Sochalska M, Villunger A, & Nilsson GP (2015) Knockdown of the antiapoptotic Bcl-2 family member A1/Bfl-1 protects mice from anaphylaxis. *Journal of immunology* 194(3):1316-1322.
200. Ullerås E, *et al.* (2008) NFAT but not NF-kappaB is critical for transcriptional induction of the prosurvival gene A1 after IgE receptor activation in mast cells. *Blood* 111(6):3081-3089.
201. Ekoff M, Strasser A, & Nilsson G (2007) FcepsilonRI aggregation promotes survival of connective tissue-like mast cells but not mucosal-like mast cells. *Journal of immunology* 178(7):4177-4183.
202. Ekoff M, *et al.* (2012) Anti-apoptotic BFL-1 is the major effector in activation-induced human mast cell survival. *PloS one* 7(6):e39117.
203. Karlberg M, Xiang Z, & Nilsson G (2008) Fc gamma RI-mediated activation of human mast cells promotes survival and induction of the pro-survival gene Bfl-1. *Journal of clinical immunology* 28(3):250-255.
204. Watson JD & Crick FH (1953) The structure of DNA. *Cold Spring Harbor symposia on quantitative biology* 18:123-131.
205. Kornberg RD (1974) Chromatin structure: a repeating unit of histones and DNA. *Science* 184(4139):868-871.
206. Luger K, Mader AW, Richmond RK, Sargent DF, & Richmond TJ (1997) Crystal structure of the nucleosome core particle at 2.8 Å resolution. *Nature* 389(6648):251-260.
207. Bannister AJ & Kouzarides T (2011) Regulation of chromatin by histone modifications. *Cell research* 21(3):381-395.
208. Jones PA & Takai D (2001) The role of DNA methylation in mammalian epigenetics. *Science* 293(5532):1068-1070.

209. Choy MK, *et al.* (2010) Genome-wide conserved consensus transcription factor binding motifs are hyper-methylated. *BMC genomics* 11:519.
210. Ohki I, *et al.* (2001) Solution structure of the methyl-CpG binding domain of human MBD1 in complex with methylated DNA. *Cell* 105(4):487-497.
211. Tahiliani M, *et al.* (2009) Conversion of 5-methylcytosine to 5-hydroxymethylcytosine in mammalian DNA by MLL partner TET1. *Science* 324(5929):930-935.
212. Maiti A & Drohat AC (2011) Thymine DNA glycosylase can rapidly excise 5-formylcytosine and 5-carboxylcytosine: potential implications for active demethylation of CpG sites. *The Journal of biological chemistry* 286(41):35334-35338.
213. Ito S, *et al.* (2011) Tet proteins can convert 5-methylcytosine to 5-formylcytosine and 5-carboxylcytosine. *Science* 333(6047):1300-1303.
214. Rea S, *et al.* (2000) Regulation of chromatin structure by site-specific histone H3 methyltransferases. *Nature* 406(6796):593-599.
215. Tsukada Y, *et al.* (2006) Histone demethylation by a family of JmjC domain-containing proteins. *Nature* 439(7078):811-816.
216. Vakoc CR, Mandat SA, Olenchock BA, & Blobel GA (2005) Histone H3 lysine 9 methylation and HP1 gamma are associated with transcription elongation through mammalian chromatin. *Molecular cell* 19(3):381-391.
217. Brownell JE & Allis CD (1996) Special HATs for special occasions: linking histone acetylation to chromatin assembly and gene activation. *Current opinion in genetics & development* 6(2):176-184.
218. Brehm A, *et al.* (1998) Retinoblastoma protein recruits histone deacetylase to repress transcription. *Nature* 391(6667):597-601.
219. Lee DY, Hayes JJ, Pruss D, & Wolffe AP (1993) A positive role for histone acetylation in transcription factor access to nucleosomal DNA. *Cell* 72(1):73-84.
220. Hockly E, *et al.* (2003) Suberoylanilide hydroxamic acid, a histone deacetylase inhibitor, ameliorates motor deficits in a mouse model of Huntington's disease. *Proceedings of the National Academy of Sciences of the United States of America* 100(4):2041-2046.
221. Ungerstedt JS, *et al.* (2005) Role of thioredoxin in the response of normal and transformed cells to histone deacetylase inhibitors. *Proceedings of the National Academy of Sciences of the United States of America* 102(3):673-678.
222. Lee RC, Feinbaum RL, & Ambros V (1993) The *C. elegans* heterochronic gene *lin-4* encodes small RNAs with antisense complementarity to *lin-14*. *Cell* 75(5):843-854.
223. Abbott AL, *et al.* (2005) The *let-7* MicroRNA family members *mir-48*, *mir-84*, and *mir-241* function together to regulate developmental timing in *Caenorhabditis elegans*. *Developmental cell* 9(3):403-414.
224. Johnson SM, *et al.* (2005) RAS is regulated by the *let-7* microRNA family. *Cell* 120(5):635-647.
225. Mendell JT & Olson EN (2012) MicroRNAs in stress signaling and human disease. *Cell* 148(6):1172-1187.

226. Sunkar R & Jagadeeswaran G (2008) In silico identification of conserved microRNAs in large number of diverse plant species. *BMC plant biology* 8:37.
227. Ambros V (2004) The functions of animal microRNAs. *Nature* 431(7006):350-355.
228. Pfeffer S, *et al.* (2004) Identification of virus-encoded microRNAs. *Science* 304(5671):734-736.
229. Lee Y, *et al.* (2004) MicroRNA genes are transcribed by RNA polymerase II. *The EMBO journal* 23(20):4051-4060.
230. Cullen BR (2004) Transcription and processing of human microRNA precursors. *Molecular cell* 16(6):861-865.
231. Lee Y, *et al.* (2003) The nuclear RNase III Drosha initiates microRNA processing. *Nature* 425(6956):415-419.
232. Han J, *et al.* (2004) The Drosha-DGCR8 complex in primary microRNA processing. *Genes & development* 18(24):3016-3027.
233. Yi R, Qin Y, Macara IG, & Cullen BR (2003) Exportin-5 mediates the nuclear export of pre-microRNAs and short hairpin RNAs. *Genes & development* 17(24):3011-3016.
234. Chendrimada TP, *et al.* (2005) TRBP recruits the Dicer complex to Ago2 for microRNA processing and gene silencing. *Nature* 436(7051):740-744.
235. Sen GL & Blau HM (2005) Argonaute 2/RISC resides in sites of mammalian mRNA decay known as cytoplasmic bodies. *Nature cell biology* 7(6):633-636.
236. Winter J & Diederichs S (2011) Argonaute proteins regulate microRNA stability: Increased microRNA abundance by Argonaute proteins is due to microRNA stabilization. *RNA biology* 8(6):1149-1157.
237. Bagga S, *et al.* (2005) Regulation by let-7 and lin-4 miRNAs results in target mRNA degradation. *Cell* 122(4):553-563.
238. Djuranovic S, Nahvi A, & Green R (2012) miRNA-mediated gene silencing by translational repression followed by mRNA deadenylation and decay. *Science* 336(6078):237-240.
239. Gilicze AB, *et al.* (2014) Myeloid-derived microRNAs, miR-223, miR27a, and miR-652, are dominant players in myeloid regulation. *BioMed research international* 2014:870267.
240. Tsai FY & Orkin SH (1997) Transcription factor GATA-2 is required for proliferation/survival of early hematopoietic cells and mast cell formation, but not for erythroid and myeloid terminal differentiation. *Blood* 89(10):3636-3643.
241. Ahn EE, *et al.* (2013) SON protein regulates GATA-2 through transcriptional control of the microRNA 23a~27a~24-2 cluster. *The Journal of biological chemistry* 288(8):5381-5388.
242. Kim D, Song J, & Jin EJ (2010) MicroRNA-221 regulates chondrogenic differentiation through promoting proteosomal degradation of slug by targeting Mdm2. *The Journal of biological chemistry* 285(35):26900-26907.
243. Gits CM, *et al.* (2013) MiR-17-92 and miR-221/222 cluster members target KIT and ETV1 in human gastrointestinal stromal tumours. *British journal of cancer* 109(6):1625-1635.

244. He H, *et al.* (2005) The role of microRNA genes in papillary thyroid carcinoma. *Proceedings of the National Academy of Sciences of the United States of America* 102(52):19075-19080.
245. Mayoral RJ, *et al.* (2009) MicroRNA-221-222 regulate the cell cycle in mast cells. *Journal of immunology* 182(1):433-445.
246. Mayoral RJ, *et al.* (2011) MiR-221 influences effector functions and actin cytoskeleton in mast cells. *PloS one* 6(10):e26133.
247. Godshalk SE, *et al.* (2011) A Variant in a MicroRNA complementary site in the 3' UTR of the KIT oncogene increases risk of acral melanoma. *Oncogene* 30(13):1542-1550.
248. Rusca N, *et al.* (2012) MiR-146a and NF-kappaB1 regulate mast cell survival and T lymphocyte differentiation. *Molecular and cellular biology* 32(21):4432-4444.
249. Biethahn K, *et al.* (2014) miRNA-155 controls mast cell activation by regulating the PI3Kgamma pathway and anaphylaxis in a mouse model. *Allergy* 69(6):752-762.
250. Qayum AA, *et al.* (2016) IL-10-Induced miR-155 Targets SOCS1 To Enhance IgE-Mediated Mast Cell Function. *Journal of immunology* 196(11):4457-4467.
251. Lee YN, *et al.* (2011) KIT signaling regulates MITF expression through miRNAs in normal and malignant mast cell proliferation. *Blood* 117(13):3629-3640.
252. Gao XN, *et al.* (2011) MicroRNA-193a represses c-kit expression and functions as a methylation-silenced tumor suppressor in acute myeloid leukemia. *Oncogene* 30(31):3416-3428.
253. Lappalainen J, Lindstedt KA, & Kovanen PT (2007) A protocol for generating high numbers of mature and functional human mast cells from peripheral blood. *Clinical and experimental allergy : journal of the British Society for Allergy and Clinical Immunology* 37(9):1404-1414.
254. Butterfield JH, Weiler D, Dewald G, & Gleich GJ (1988) Establishment of an immature mast cell line from a patient with mast cell leukemia. *Leukemia research* 12(4):345-355.
255. Sundstrom M, *et al.* (2003) Functional and phenotypic studies of two variants of a human mast cell line with a distinct set of mutations in the c-kit proto-oncogene. *Immunology* 108(1):89-97.
256. Kirshenbaum AS, *et al.* (2003) Characterization of novel stem cell factor responsive human mast cell lines LAD 1 and 2 established from a patient with mast cell sarcoma/leukemia; activation following aggregation of FcepsilonRI or Fc gammaRI. *Leukemia research* 27(8):677-682.
257. Kolmert J, *et al.* (2014) A quantitative LC/MS method targeting urinary 1-methyl-4-imidazoleacetic acid for safety monitoring of the global histamine turnover in clinical studies. *Analytical and bioanalytical chemistry* 406(6):1751-1762.
258. Ottina E, *et al.* (2012) Targeting antiapoptotic A1/Bfl-1 by in vivo RNAi reveals multiple roles in leukocyte development in mice. *Blood* 119(25):6032-6042.
259. Nishihara E, Hiyama TY, & Noda M (2011) Osmosensitivity of transient receptor potential vanilloid 1 is synergistically enhanced by distinct activating stimuli such as temperature and protons. *PloS one* 6(7):e22246.

260. Liedtke W & Friedman JM (2003) Abnormal osmotic regulation in *trpv4*^{-/-} mice. *Proceedings of the National Academy of Sciences of the United States of America* 100(23):13698-13703.
261. Ritter CA, *et al.* (2005) Cellular export of drugs and signaling molecules by the ATP-binding cassette transporters MRP4 (ABCC4) and MRP5 (ABCC5). *Drug metabolism reviews* 37(1):253-278.
262. Leitch AE, *et al.* (2010) The cyclin-dependent kinase inhibitor R-roscovitine down-regulates Mcl-1 to override pro-inflammatory signalling and drive neutrophil apoptosis. *European journal of immunology* 40(4):1127-1138.
263. White CH, *et al.* (2015) Mixed effects of suberoylanilide hydroxamic acid (SAHA) on the host transcriptome and proteome and their implications for HIV reactivation from latency. *Antiviral research* 123:78-85.
264. Muhlenberg T, *et al.* (2009) Inhibitors of deacetylases suppress oncogenic KIT signaling, acetylate HSP90, and induce apoptosis in gastrointestinal stromal tumors. *Cancer research* 69(17):6941-6950.
265. Damiani E, Puebla-Osorio N, Gorbea E, & Ullrich SE (2015) Platelet-Activating Factor Induces Epigenetic Modifications in Human Mast Cells. *The Journal of investigative dermatology* 135(12):3034-3040.
266. Londin E, *et al.* (2015) Analysis of 13 cell types reveals evidence for the expression of numerous novel primate- and tissue-specific microRNAs. *Proceedings of the National Academy of Sciences of the United States of America* 112(10):E1106-1115.
267. Henry EK, *et al.* (2016) Carbonic anhydrase enzymes regulate mast cell-mediated inflammation. *The Journal of experimental medicine* 213(9):1663-1673.