



UNIVERSITY OF  
BIRMINGHAM

SONOELECTROCHEMICAL (20 kHz) PRODUCTION  
OF HYDROGEN FROM AQUEOUS SOLUTIONS

BY

DANIEL SYMES

Thesis submitted in accordance with the requirements of  
The University of Birmingham for the degree of  
MASTER OF RESEARCH

School of Chemical Engineering  
College of Engineering and Physical Sciences  
The University of Birmingham

February 2011

UNIVERSITY OF  
BIRMINGHAM

**University of Birmingham Research Archive**

**e-theses repository**

This unpublished thesis/dissertation is copyright of the author and/or third parties. The intellectual property rights of the author or third parties in respect of this work are as defined by The Copyright Designs and Patents Act 1988 or as modified by any successor legislation.

Any use made of information contained in this thesis/dissertation must be in accordance with that legislation and must be properly acknowledged. Further distribution or reproduction in any format is prohibited without the permission of the copyright holder.

## **ACKNOWLEDGEMENTS**

I am whole heartily thankful to my supervisor Dr Bruno G. Pollet, whose encouragement, supervision, and support from the preliminary to concluding level enabled me to develop and understanding of the subject.

I would also like to express my gratitude to the EPSRC for providing the funding for this research, and thank my family and girlfriend for their love and support throughout.

Finally I offer my regards to Matthew Lepasant whose assistance in the laboratory was of great aid to me, blessings to Professor Kevin Kendall, Dr Waldemar Bujalski, Dr Aman Dhir, Oliver Curnick, James Courtney, Tony Meadowcroft and fellow researchers at the PEM Fuel Cell Research Group and the Centre for Hydrogen and Fuel Cell Research at the University of Birmingham, who supported me in any respect during the completion of the project.

## **ABSTRACT**

There are various methods of producing Hydrogen. These include electrolysis, which this work is based upon, and steam reforming; currently the most commercially viable method.

The research herein investigates methods of producing 'green' Hydrogen more efficiently by using ultrasound (20 kHz) combined to electrolysis. Previous studies have shown that ultrasound enhances mass-transfer of electro-active species from the bulk solution to the electrode surface in any electrolytic system and mechanically removes gas bubbles on the electrode surface.

This work takes this previous research further by quantifying actual hydrogen gas output. The hydrogen evolution reaction was then directly compared with that calculated using the Ideal Gas Equation to quantify the efficiency of the electrolysis system.

It was observed that ultrasound lowers the anodic and cathodic overpotentials due to gas removal at the electrode surface induced by cavitation and increased mass-transfer. However, it was found that ultrasound did not increase the rate of Hydrogen production. During experimentation it was seen that the force exhibited on the electrodes by ultrasonic waves limited bubble evolution on the electrode surface.

Issues associated with the ultrasonic reactor geometry and the ultrasonic transducer size are also discussed as potential reasons for this result.

# CONTENTS

1. INTRODUCTION & LITERATURE SURVEY .....	1
1.1 Global Warming and Carbon Dioxide.....	1
1.2 Hydrogen as an Energy Carrier.....	4
1.2.1 What is Hydrogen? .....	4
1.2.2 Methods of Hydrogen Production .....	6
1.2.3 Fuel Cell Technology.....	13
1.3 Principles of Electrochemistry.....	17
Method 1: Decomposition Voltage .....	19
Method 2: Discharge Potential .....	20
1.4 Electrolysis.....	22
1.5 Sonoelectrochemistry .....	25
1.6 Sonoelectrochemical Production of Hydrogen .....	30
2. EXPERIMENTAL METHOD .....	33
2.1 Equipment & Parameters.....	37
3. RESULTS AND DISCUSSION .....	38
3.1 Preliminary Experiments .....	38
3.1.1 Current Voltage Curves .....	38
3.1.2 Overpotential Determination.....	43
3.2 Custom Glassware Experiments.....	46
3.2.1 Current-Voltage Curves.....	46
3.2.2 Hydrogen Evolution Rate .....	49
3.2.3 Hydrogen Efficiency Data .....	53
3.2.4 Energy Efficiency Data.....	56
3.2.5 Ultrasonic Power Determination .....	56
3.3 Erosion of the Electrodes .....	57
3.4 Experiments with Industrial Electrolysers.....	58

3.4.1 Introduction.....	58
3.4.2 Data Analysis .....	60
4. CONCLUSIONS .....	63
4.1 Comparison for Industrial Electrolyser and Sonoelectrochemical Cell.....	66
5. FUTURE WORK .....	69
5.1 Electrolytes.....	69
5.2 Electrode Parameters.....	70
5.3 Electrolyte Temperature .....	70
5.4 Ultrasonic Parameters.....	71
6. REFERENCES .....	72
7. APPENDICES .....	77
7.1 Appendix I - Data Tables.....	77
7.1.1 Preliminary Experiments .....	77
7.1.2 Custom Glassware Experiments.....	83
7.2 Appendix II - Graphs.....	143
7.2.1 Preliminary Experiments .....	143
7.2.2 Custom Glassware Experiments.....	146
7.3 Appendix III – Decomposition Potential Calculations .....	155
7.4 Appendix IV - Ultrasound Power Data Tables .....	158
7.5 Appendix V - Health & Safety .....	159
7.6 Appendix VI – Conferences Attended & Posters Presented .....	163

## TABLE OF FIGURES

Figure 1: Greenhouse Effect Diagram. Source: United Nation Environment Programme.....	1
Figure 2: Flammability Range of H <sub>2</sub> when compared to other fuels. Source: Hydrogen-FC Ltd.....	5
Figure 3: A summary of the current technologies available to produce Hydrogen [40] .....	12
Figure 4: Diagram of a PEMFC [43] .....	14
Figure 5: Decomposition Voltage Calculation Demonstration Graph.....	20
Figure 6: Schematic of Ultrasonic Phenomena [69].....	27
Figure 7: Custom Designed Glassware & Experimental Setup.....	33
Figure 8: Experimental Setup for Preliminary Experiments.....	34
Figure 9: Decomposition Curves for NaOH solution .....	38
Figure 10: Decomposition Curves for NaCl solution .....	39
Figure 11: Decomposition Curves for H <sub>2</sub> SO <sub>4</sub> solution.....	40
Figure 12: Current Voltage Comparison Graph for all three electrolytes .....	41
Figure 13: Current Enhancement for NaOH solution.....	46
Figure 14: Current Enhancement for NaCl solution.....	47
Figure 15: Current Enhancement for H <sub>2</sub> SO <sub>4</sub> solution.....	48
Figure 16: Hydrogen Production Enhancement for NaOH solution.....	49
Figure 17: Hydrogen Production Enhancement for NaCl solution.....	50
Figure 18: Hydrogen Production Enhancement for H <sub>2</sub> SO <sub>4</sub> solution.....	51
Figure 19: Hydrogen Output Efficiency Enhancement for NaOH solution.....	53
Figure 20: Hydrogen Output Efficiency Enhancement for NaCl solution.....	54
Figure 21: Hydrogen Output Efficiency Enhancement for H <sub>2</sub> SO <sub>4</sub> solution.....	55
Figure 22: Image of Experimental Setup.....	58
Figure 23: Image showing small leak on side tank.....	59
Figure 24: Decomposition Curves for KOH solution.....	60
Figure 25: HHO Production for KOH solution.....	62
Figure 26: Diagram defining the Sonication Distance .....	66
Figure 27: Table of Voltage Current Data for NaOH .....	77
Figure 28: Table of Voltage Current Data for NaCl .....	78
Figure 29: Table of Voltage Current Data for H <sub>2</sub> SO <sub>4</sub> .....	79
Figure 30: Table of Voltage Current Data for NaOH Sonicated.....	80
Figure 31: Table of Voltage Current Data for NaCl Sonicated.....	81
Figure 32: Table of Voltage Current Data for H <sub>2</sub> SO <sub>4</sub> Sonicated .....	82
Figure 33: Data for 0.1M NaOH Silent.....	83
Figure 34: Data for 0.2M NaOH Silent.....	84
Figure 35: Data for 0.3M NaOH Silent.....	85
Figure 36: Data for 0.4M NaOH Silent.....	86
Figure 37: Data for 0.5M NaOH Silent.....	87
Figure 38: Data for 1.0M NaOH Silent.....	88
Figure 39: Data of NaOH Efficiency of H <sub>2</sub> production .....	89
Figure 40: Data for 0.1M NaCl Silent.....	90

Figure 41: Data for 0.2M NaCl Silent.....	91
Figure 42: Data for 0.3M NaCl Silent.....	92
Figure 43: Data for 0.4M NaCl Silent.....	93
Figure 44: Data for 0.5M NaCl Silent.....	94
Figure 45: Data for 1.0M NaCl Silent.....	95
Figure 46: Data of NaCl Efficiency of H <sub>2</sub> production .....	96
Figure 47: Data for 0.1M H <sub>2</sub> SO <sub>4</sub> Silent.....	97
Figure 48: Data for 0.2M H <sub>2</sub> SO <sub>4</sub> Silent.....	98
Figure 49: Data for 0.3M H <sub>2</sub> SO <sub>4</sub> Silent.....	99
Figure 50: Data for 0.4M H <sub>2</sub> SO <sub>4</sub> Silent.....	100
Figure 51: Data for 0.5M H <sub>2</sub> SO <sub>4</sub> Silent.....	101
Figure 52: Data for 1.0M H <sub>2</sub> SO <sub>4</sub> Silent.....	102
Figure 53: Data of H <sub>2</sub> SO <sub>4</sub> Efficiency of H <sub>2</sub> production .....	103
Figure 54: Data for 0.1M NaOH Sonicated.....	104
Figure 55: Data for 0.2M NaOH Sonicated.....	105
Figure 56: Data for 0.3M NaOH Sonicated.....	106
Figure 57: Data for 0.4M NaOH Sonicated.....	107
Figure 58: Data for 0.5M NaOH Sonicated.....	108
Figure 59: Data for 1.0M NaOH Sonicated.....	109
Figure 60: Data of NaOH Efficiency of H <sub>2</sub> production .....	110
Figure 61: Data for 0.1M NaCl Sonicated.....	111
Figure 62: Data for 0.2M NaCl Sonicated.....	112
Figure 63: Data for 0.3M NaCl Sonicated.....	113
Figure 64: Data for 0.4M NaCl Sonicated.....	114
Figure 65: Data for 0.5M NaCl Sonicated.....	115
Figure 66: Data for 1.0M NaCl Sonicated.....	116
Figure 67: Data of NaCl Efficiency of H <sub>2</sub> production .....	117
Figure 68: Data for 0.1M H <sub>2</sub> SO <sub>4</sub> Sonicated.....	118
Figure 69: Data for 0.2M H <sub>2</sub> SO <sub>4</sub> Sonicated.....	119
Figure 70: Data for 0.3M H <sub>2</sub> SO <sub>4</sub> Sonicated.....	120
Figure 71: Data for 0.4M H <sub>2</sub> SO <sub>4</sub> Sonicated.....	121
Figure 72: Data for 0.5M H <sub>2</sub> SO <sub>4</sub> Sonicated.....	122
Figure 73: Data for 1.0M H <sub>2</sub> SO <sub>4</sub> Sonicated.....	123
Figure 74: Data of H <sub>2</sub> SO <sub>4</sub> Efficiency of H <sub>2</sub> production .....	124
Figure 75: Data for 0.1M NaOH Ultrasound Enhancement .....	125
Figure 76: Data for 0.2M NaOH Ultrasound Enhancement .....	126
Figure 77: Data for 0.3M NaOH Ultrasound Enhancement .....	127
Figure 78: Data for 0.4M NaOH Ultrasound Enhancement .....	128
Figure 79: Data for 0.5M NaOH Ultrasound Enhancement .....	129
Figure 80: Data for 1.0M NaOH Ultrasound Enhancement .....	130
Figure 81: Data for 0.1M NaCl Ultrasound Enhancement .....	131
Figure 82: Data for 0.2M NaCl Ultrasound Enhancement .....	132
Figure 83: Data for 0.3M NaCl Ultrasound Enhancement .....	133



Figure 84: Data for 0.4M NaCl Ultrasound Enhancement .....	134
Figure 85: Data for 0.5M NaCl Ultrasound Enhancement .....	135
Figure 86: Data for 1.0M NaCl Ultrasound Enhancement .....	136
Figure 87: Data for 0.1M H <sub>2</sub> SO <sub>4</sub> Ultrasound Enhancement .....	137
Figure 88: Data for 0.2M H <sub>2</sub> SO <sub>4</sub> Ultrasound Enhancement .....	138
Figure 89: Data for 0.3M H <sub>2</sub> SO <sub>4</sub> Ultrasound Enhancement .....	139
Figure 90: Data for 0.4M H <sub>2</sub> SO <sub>4</sub> Ultrasound Enhancement .....	140
Figure 91: Data for 0.5M H <sub>2</sub> SO <sub>4</sub> Ultrasound Enhancement .....	141
Figure 92: Data for 1.0M H <sub>2</sub> SO <sub>4</sub> Ultrasound Enhancement .....	142
Figure 93: Current Voltage Graph for Silent NaOH solution .....	143
Figure 94: Current Voltage Graph for Silent NaCl solution .....	143
Figure 95: Current Voltage Graph for Silent H <sub>2</sub> SO <sub>4</sub> solution .....	144
Figure 96: Current Voltage Graph for Sonicated NaOH solution .....	144
Figure 97: Current Voltage Graph for Sonicated NaCl solution .....	145
Figure 98: Current Voltage Graph for Sonicated H <sub>2</sub> SO <sub>4</sub> solution .....	145
Figure 99: Current Voltage Graph for Silent NaOH solution .....	146
Figure 100: Current Voltage Graph for Silent NaCl solution .....	146
Figure 101: Current Voltage Graph for Silent H <sub>2</sub> SO <sub>4</sub> solution .....	147
Figure 102: Current Voltage Graph for Sonicated NaOH solution .....	147
Figure 103: Current Voltage Graph for Sonicated NaCl solution .....	148
Figure 104: Current Voltage Graph for Sonicated H <sub>2</sub> SO <sub>4</sub> solution .....	148
Figure 105: Hydrogen Production Graph for Silent NaOH solution .....	149
Figure 106: Hydrogen Production Graph for Silent NaCl solution .....	149
Figure 107: Hydrogen Production Graph for Silent H <sub>2</sub> SO <sub>4</sub> solution .....	150
Figure 108: Hydrogen Production Graph for Sonicated NaOH solution .....	150
Figure 109: Hydrogen Production Graph for Sonicated NaCl solution .....	151
Figure 110: Hydrogen Production Graph for Sonicated H <sub>2</sub> SO <sub>4</sub> solution .....	151
Figure 111: Hydrogen Production Efficiency Graph for Silent NaOH solution.....	152
Figure 112: Hydrogen Production Efficiency Graph for Silent NaCl solution.....	152
Figure 113: Hydrogen Production Efficiency Graph for Silent H <sub>2</sub> SO <sub>4</sub> solution.....	153
Figure 114: Hydrogen Production Efficiency Graph for Sonicated NaOH solution.....	153
Figure 115: Hydrogen Production Efficiency Graph for Sonicated NaCl solution.....	154
Figure 116: Hydrogen Production Efficiency Graph for Sonicated H <sub>2</sub> SO <sub>4</sub> solution.....	154
Figure 117: Temperature variance table for each electrolyte at varying ultrasonic powers.....	158
Figure 118: dT/dt gradients calculated for each electrolyte.....	158
Figure 119: Ultrasound Power Table.....	158

## TABLE OF TABLES

Table 1: Comparison of Fuel Cell Technologies [48] .....	15
Table 2: Preliminary Experimental Electrolyte Masses .....	35
Table 3: Custom Glassware Experimental Electrolyte Masses.....	35
Table 4: Table of Decomposition Voltages.....	43
Table 5: Table of Overpotentials.....	43
Table 6: Table of Average Overpotentials.....	44
Table 7: Chemical Properties for each electrolyte solution [94].....	56
Table 8: Ultrasonic Power Density Table .....	57
Table 9: Decomposition Voltages for Industrial Electrolyser .....	61

# 1. INTRODUCTION & LITERATURE SURVEY

Global energy demand and security as well as increasing world population are leading to an inevitable shortage of fossil fuels which is the primary resource of our energy requirement. Fossil fuels are made up of hydrocarbons, and as their availability becomes increasingly limited, other energy sources will need to be found, in other words, research into new sources of energy is urgently required [1].

## 1.1 Global Warming and Carbon Dioxide

Carbon dioxide (CO<sub>2</sub>), one of the main contributors to global warming, was first discovered in 1753 by Joseph Black whilst he was at the University of Edinburgh completing his medical studies. It was not for another 50 years until Jean-Baptiste Fourier suggested that an atmospheric effect kept the planet warmer than it should be. This occurred in 1827 whereby Fourier used the analogy of a 'greenhouse' to describe this atmospheric effect [2].

Then in 1896 a direct link between CO<sub>2</sub> and global warming was found, where Arrhenius proposed that CO<sub>2</sub> emissions from burning

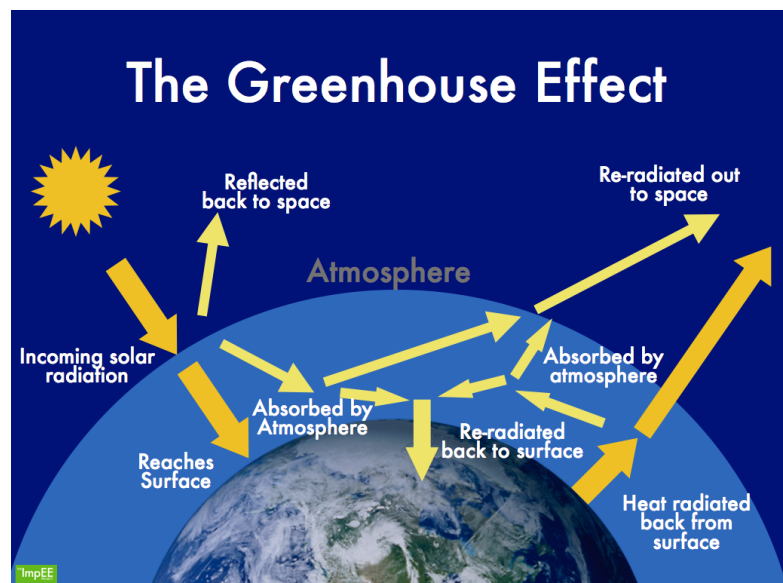

Figure 1: Greenhouse Effect Diagram. Source: United Nation Environment Programme

coal would enhance the planet's greenhouse effect and lead to global warming. Since the industrial revolution, which began in the early 18<sup>th</sup> century, the amount of CO<sub>2</sub> in the atmosphere has increased by 35%. It is reported that the current level of CO<sub>2</sub> in the atmosphere is higher than it was 650,000 years ago [3].

CO<sub>2</sub> absorbs and emits waves in the infrared (IR) spectrum and it is known as a greenhouse gas (GHG). Other GHGs include NO<sub>x</sub>, CO, O<sub>3</sub>, SO<sub>x</sub> and H<sub>2</sub>O. As the Earth is heated by the Sun, the greenhouse gases in the troposphere absorb the reflected solar radiation and emit it back to Earth. The amount of solar radiation absorbed is directly proportional to the amount of greenhouse gases in the troposphere. As the level of CO<sub>2</sub> in the atmosphere increases, more solar radiation becomes trapped thus increasing the temperature of the planet leading to global warming [4] (Figure 1 [5]).

Fossil fuels when combusted to produce energy create CO<sub>2</sub> and other GHGs as by-products. The CO<sub>2</sub> concentration in the Earth's atmosphere has been steadily increasing for the last 100 years [6], due to the rise in quantities of fossil fuels being burnt together with rapid deforestation. Deforestation results in a reduction of photosynthesis i.e. decreasing the removal carbon dioxide from the atmosphere and its replacement with oxygen in turn causing CO<sub>2</sub> levels in the atmosphere to rise [7]. The rising population of our planet (currently ca. 6 billion and expected to rise over 9 billion by 2050) is also leading to higher emissions. Indeed, this increase in population will cause a growing demand for food, livestock and energy, all of which will result in higher CO<sub>2</sub> emissions [8].

Another cause of increasing CO<sub>2</sub> concentration in the atmosphere is due to the depletion of the ozone (O<sub>3</sub>) layer in the upper atmosphere. O<sub>3</sub> prevents harmful UV rays from the Sun reaching the surface of the planet and if there was no ozone, no life would exist!

Both of these phenomena have resulted in an increase in average global temperature of around 2-4°C over the last 100 years. In that period, it is reported that the burning of fossil fuels has produced about three quarters of the increase in CO<sub>2</sub> levels and the remaining is due to land use changes e.g. deforestation (e.g. Amazon forest) [7].

Throughout the history of our planet, the Earth has always been changing, sometimes through natural causes. More recently the term 'climate change' has been used to describe changes in our climate since the early 20th century. The changes in climate we have seen recently along with the

changes predicted over the next 100 years are not solely due to natural causes, but are thought to be caused by human activities (anthropogenic activities) [2].

Governments started to realise the need for action by raising awareness of the alarming global issue. In 1979, the world held its first climate conference. The conference called upon governments “*to foresee and prevent potential man-made changes in climate*”. In 1988, the United Nations (UN) set up the Intergovernmental Panel on Climate Change (IPCC) to analyse and report on scientific findings [2].

The first Earth Summit was held in Rio de Janeiro in 1992, where the United Nations Framework Convention on Climate Change (UNFCCC) was signed by 154 nations. It was agreed to prevent “dangerous” warming from GHGs and set voluntary targets for reducing their emissions. The UNFCCC agreed voluntary targets in 1992 and the Kyoto Protocol was the first international treaty to set legally binding GHG emissions cuts for industrialised nations. The agreement was signed by 178 countries in 1997 and came into force in 2005 [2].

However, a potential solution to this problem presented above is the use of Hydrogen as an energy carrier/vector, and this is hereby discussed.

## 1.2 Hydrogen as an Energy Carrier

### 1.2.1 What is Hydrogen?

Hydrogen was first discovered in 1766 by Henry Cavendish through the reactions of zinc (Zn) and hydrochloric acid (HCl), which led to the discovery that water is made up of Hydrogen (H<sub>2</sub>) and Oxygen (O<sub>2</sub>) [9]. This was the only method of Hydrogen production (and in fact of 'green' Hydrogen) for over a hundred years until British scientists William Nicholson and Sir Anthony Carlisle discovered that applying an electrical current to water produces Hydrogen and Oxygen gases in 1800 [10]. This was later termed 'Water Electrolysis'.

In 1970, the Electrochemist John Bockris coined the term 'Hydrogen economy'[11, 12] and at the first World Hydrogen Conference in 1976 the idea of a Hydrogen economy was first discussed, identifying Hydrogen energy as a clean energy carrier for the future. It was concluded that a large proportion of energy supplied by Hydrogen, could be made from sources that have no net GHG emissions. The concept of a Hydrogen economy came about due to the limitations of fossil fuel supply and concerns about global warming [12].

Hydrogen is currently commercially produced by steam reforming (SR), which unfortunately releases GHGs, most notably carbon monoxide (CO) and CO<sub>2</sub> into the atmosphere. This results in the Hydrogen energy not being carbon neutral and therefore not meeting the objectives proposed in 1976 at the World Hydrogen Conference. Currently, it is more cost effective to produce Hydrogen from fossil fuels; therefore producers do not invest in the Hydrogen produced from renewable sources.

Many academics, some politicians and industrialists believe that the only realistic method to produce 'green' Hydrogen without creating any GHGs is through the use of renewable energy sources. These include solar (photovoltaic and photocatalysis), wind, tidal, geothermal and hydroelectric energy sources. Energy can be produced by these sources indefinitely as the primary sources of the energy

(the Sun for solar power, heat produced from the Earth for geothermal energy) will always exist whilst there is life on Earth. It is important to note that Hydrogen is an energy carrier, not a primary energy source [13]. Another source capable of producing Hydrogen is nuclear energy (via Electrolysis – see later). This method for producing Hydrogen has a lot of sceptics, but there is a great public concern over the disposal of the radioactive waste created from the process.

Hydrogen is predicted to be one of the future fuels for the automotive, buildings and portable electronic sectors [14]. In each of these sectors, the Hydrogen energy is converted to electricity and heat by the fuel cell with water being the only by-product.

Hydrogen is an extremely flammable substance and must be handled with care, with a wide range of flammability limits and a low ignition energy [15] (Figure 2 [16]). This means that Hydrogen must be stored in a heat free environment with no source of ignition in the vicinity. These properties also create a high risk of fire and/or explosion [15]. When Hydrogen

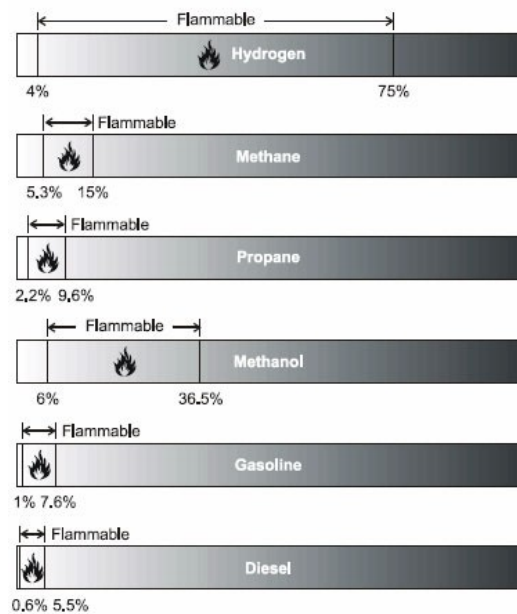

**Figure 2: Flammability Range of H<sub>2</sub> when compared to other fuels. Source: Hydrogen-FC Ltd**

ignites, it burns with a colourless flame, which in itself is a hazard since it is difficult to detect. Another potential hazard of Hydrogen is if it leaks from a high pressure source (350 or 700 bar) Hydrogen self-heats itself, creating the risk of fires and/or explosions [17].

Currently vehicles running on petrol/diesel are known to have low energy efficiencies (<40%), but the lack of alternative fuels and an infrastructure means that there is no direct competition for petrol/diesel. Gasoline used in Internal Combustion Engines (ICEs) is found to have an energy efficiency of approximately 35%, whereas Hydrogen has an efficiency of approximately 41%. Therefore, Hydrogen supply chains would release significantly less CO<sub>2</sub> than the production of

gasoline for Hybrid Electric Vehicles. Emissions created during production could be reduced by Carbon Capture and Sequestration (CCS) at the site of production [18].

The use of Hydrogen in a Hydrogen Fuel Cell or a Hydrogen ICE, requires storage that has inherent and high volumetric efficiency. Metal Hydrides (M-H) offer alternatives to storing Hydrogen in gas and liquid form and are typically 0.5-3% weight H<sub>2</sub>. They store Hydrogen in what is essentially a solid form and offer the potential of high safety, volume efficiency, low pressure containment (<10 bar) and operating conditions at ambient temperatures [19].

The introduction of alternative fuels will require significant, long-term investments for setting up and expanding infrastructures[20]. This is especially true in the case of a Hydrogen economy based on renewable resources. Today's decisions therefore should be oriented towards robust options with stable prospects even under changing future framework conditions. Long-term scenarios are one tool for finding robust options because they allow outlining future developments of energy systems in relation to a variety of framework conditions and policy settings.

These scenarios refer to the total energy system so as to provide a complete balance of energy consumption and GHG emissions, and to take shifts between different sectors into account. A scenario analysis is required because depending on how fast the share of HFC vehicles expands, the impacts on final energy consumption, the energy demand for Hydrogen, and the resulting GHG emissions will differ [18].

### **1.2.2 Methods of Hydrogen Production**

Currently 50 million tonnes of Hydrogen are produced globally every year. It is predicted that the production will rise by 10% year-on-year over the next decade. Steam reforming (SR) is the most widely used method to produce Hydrogen and currently accounts for 95-96% of global Hydrogen production where as electrolysis only contributes 4-5%.



### ***1.2.2.1 Hydrogen Production by Electrolysis***

Water electrolysis involves passing an electrical current through water, to split the water molecules into Hydrogen and Oxygen [21], both can then be used directly in PEMFCs (see later). The Hydrogen produced is very pure (>99.999%) and therefore will not poison the catalyst (platinum) in the fuel cell (see later). Splitting water requires a very high current, since water has a high resistance (i.e. low conductivity), therefore the addition of an electrolyte (e.g. solid or liquid) increases the mobility of electrons (and ions) in the solution and allows a current to flow between the electrodes (anode and cathode). The electrolytes used in this study are: sulphuric acid ( $H_2SO_4$ ), sodium hydroxide (NaOH) and sodium chloride (NaCl).

At current electricity prices, the energy used to create the electrical power is more valuable than the Hydrogen gas produced from electrolysis [22]. However, if the source of electricity originates from renewable sources, then no pollution is created by this method of Hydrogen production [23].

At this time, this process is not as widely used as Steam Reforming (SR) and Hydrogen can be obtained more affordably from fossil fuels. As non-renewable resources decline, production of  $H_2$  via electrolysis (using renewable technologies or/and nuclear) will become more commercially viable.

### ***1.2.2.2 Electrolysis based on Alkaline Fuel Cell (AFC) Technology***

Alkaline Fuel Cell is the most developed fuel cell technology (invented by Francis Bacon at Cambridge University in the 1950's) which was used onboard NASA's Apollo space program. Its functioning is very similar to that of a PEMFC (see later) with the notable differences being the use of pure Oxygen instead of air and the electrolyte is usually an aqueous alkaline solution. By comparison with other fuel cells, the AFC is the most efficient fuel cell, with the ability to reach 70% efficiency (electrical).

An alkaline electrolysis cell (AEC) operates oppositely to an AFC, where electrical energy is applied to an alkaline solution to produce pure Hydrogen and Oxygen gases.

### **1.2.2.3 Electrolysis based on PEMFC**

The electrolysis that uses a Solid Polymer Electrolyte (SPE) instead of a liquid alkaline electrolyte is termed PEM Electrolysis. No hazardous alkaline solutions are used and the only additive is water whereby a direct current (DC) electrical is applied. This produces Hydrogen and Oxygen, the same as an AEC.

### **1.2.2.4 High Temperature Electrolysis**

This form of electrolysis is usually carried out in a reverse solid oxide fuel cell (SOFC), called a solid oxide electrolysis cell (SOEC). This method is best used when the energy supply is in the form of heat e.g. solar, thermal or nuclear. With normal electrolysis, the energy is converted from electrical to heat to chemical energy, dissipating substantial energy in the process. Since the energy source here is heat, it is converted once to chemical energy. This potentially doubles the efficiency of the process by up to 50% [24]. Currently this process has only been demonstrated on the lab scale and has not been proven to work commercially [25].

### **1.2.2.5 Steam Methane Reforming (SMR)**

Fuel Cells are not yet regarded as carbon neutral. They do not produce any carbon emissions when in use, but as stated previously, the production of Hydrogen is currently derived from steam reforming. The mechanism is shown below [26].

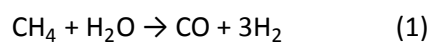

The reaction is carried out at high temperatures (700-1,100°C) where the methane used to reform the steam is made from fossil fuels which in turn does not make this production method of Hydrogen emission free [27].

Furthermore, additional CO<sub>2</sub> can be recovered by adding more water and lowering the temperature of the reaction to 170°C according to Equation (2):

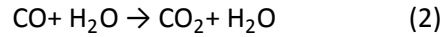

The oxygen atom is removed from additional water to oxidise CO to CO<sub>2</sub>, which provides energy to produce extra Hydrogen (see Equation 1) [27].

#### ***1.2.2.6 Biological Hydrogen Production***

In an algae bioreactor, algae usually produce O<sub>2</sub> under normal photosynthesis, but it has been shown that by depriving algae of sulphur, they produce H<sub>2</sub> instead. This process can be energy efficient by exceeding the energy used to convert sunlight to H<sub>2</sub> [28]. Feedstocks for this process can include waste streams, since bacteria feed on hydrocarbons and exhale Hydrogen and carbon dioxide. The carbon dioxide can also be sequestered, therefore reducing the potential of pollution [29].

#### ***1.2.2.7 Hydrogen Production from Radiowaves***

This process can be used in NaCl (sodium chloride) solutions of 1-30% concentrations. Radiofrequency radiation produces H<sub>2</sub> from water/salt solutions and seawater by chemical decomposition. The radiation causes the ions in solution to vibrate and Van der Waals forces cause the Hydrogen and oxygen ions to separate [30].

#### ***1.2.2.8 7 Hydrogen Production from the Kvaerner Process***

The Kvaerner Process is the production of Hydrogen and carbon black from liquid hydrocarbons. This occurs at 1600°C in a plasma burner. In this process, 100% of the natural gas is transformed into carbon black whereby the Hydrogen gas is produced in an energy efficient way [31].

#### ***1.2.2.9 7 Hydrogen Production from Pyrolysis***

##### ***a) Coal Gasification***

Another method of Hydrogen production is coal gasification. This process involves the reaction of coal with oxygen gas and water to produce 'syngas', which consists of Hydrogen and CO [32]. Hydrogen can then be separated from the CO and used as a fuel.

The process involves heating up the carbonaceous particles until they form char which is then combusted to form CO and CO<sub>2</sub>. The gasification process happens as the char reacts with the carbon dioxide and steam to form H<sub>2</sub> and CO [32].

#### ***b) Biomass Conversion***

Biomass can undergo a similar process called biomass gasification [33]. This involves the reaction of biomass with oxygen or steam at high temperatures to produce syngas.

##### ***1.2.2.10 Hydrogen Production from Fermentation***

Fermentative Hydrogen production consists of Biohydrogen being produced from organic substrates. This reaction involves the use of a diverse group of bacteria using various enzyme systems to produce Biohydrogen. The reaction is similar to that of anaerobic respiration, since Biohydrogen is produced in the absence of oxygen (air) [34]. There are two main types of fermentation, dark fermentation which does not require light to produce H<sub>2</sub>, and photofermentation which does require light [34].

##### ***1.2.2.11 7 Hydrogen Production from Nuclear***

New generation nuclear reactors are producing Hydrogen as well as electricity. The advantage that nuclear offers is that it can shift the reaction between the two e.g. producing electricity during the day or at high demand and then shifting the reaction to produce Hydrogen at night, when electricity is not widely used. If the H<sub>2</sub> is produced economically, it will compete with existing energy storage schemes [35].

##### ***1.2.2.12 Hydrogen Production from Thermal Processes***

At elevated temperatures (2000-3000°C), water splits into its main components Hydrogen and Oxygen. Lower temperatures can be used if a catalyst, such as zinc or zinc oxide is introduced to the system. The disadvantage in thermal energy is the energy required to create the high temperature and the stress requirement on the equipment used [36].

#### **1.2.2.13 Hydrogen Production from Chemical Processes**

Hydrogen can be produced by chemical means involving the reaction of aluminium (Al) with water (H<sub>2</sub>O) in the presence of a sodium hydroxide (NaOH) catalyst. The reaction mechanism is shown below:

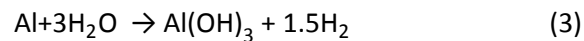

Al acts as a Hydrogen storage device in this case and since the oxidation reaction is exothermic, the operating conditions are only mild temperatures and pressures. This gives a stable and compact storage for Hydrogen [37].

#### **1.2.2.14 Hydrogen Production from Thermochemical Processes**

This method of production uses heat instead of electricity to dissociate water into its constituents (H<sub>2</sub> and O<sub>2</sub>). The heat can be provided from any energy source, primary or renewable, although using renewable energy sources creates less pollution [38].

#### **1.2.2.15 Photoelectrochemical Water Splitting**

This production method for Hydrogen uses solar energy to electrolyse water and dissociate it into Hydrogen and Oxygen. This process involves two separate systems of turning light into electricity via photovoltaic cells and using this energy to electrolyse the water, which are connected together via an AC/DC converter to produce Hydrogen. This is currently the cleanest way to produce Hydrogen [39].

#### **1.2.2.16 Possible Future Hydrogen Productions**

Competition to electrolysis for renewable 'green' Hydrogen production comes from biomass. The raw biomass undergoes anaerobic digestion, which creates methane (CH<sub>4</sub>) and a solid waste char. This methane can then be reformed with steam to produce Hydrogen. However, this process still does not remove carbon from the cycle, and therefore GHGs will be produced.

Although the purity of the Hydrogen produced by the anaerobic digestion and reformer pathway is not as great as that the Hydrogen produced by electrolysis, the use of gas separation membranes can

greatly improve its purity. The use of amine scrubbers can reduce the level of CO<sub>2</sub> and sulphides in the gas produced, which could further enhance the purity.

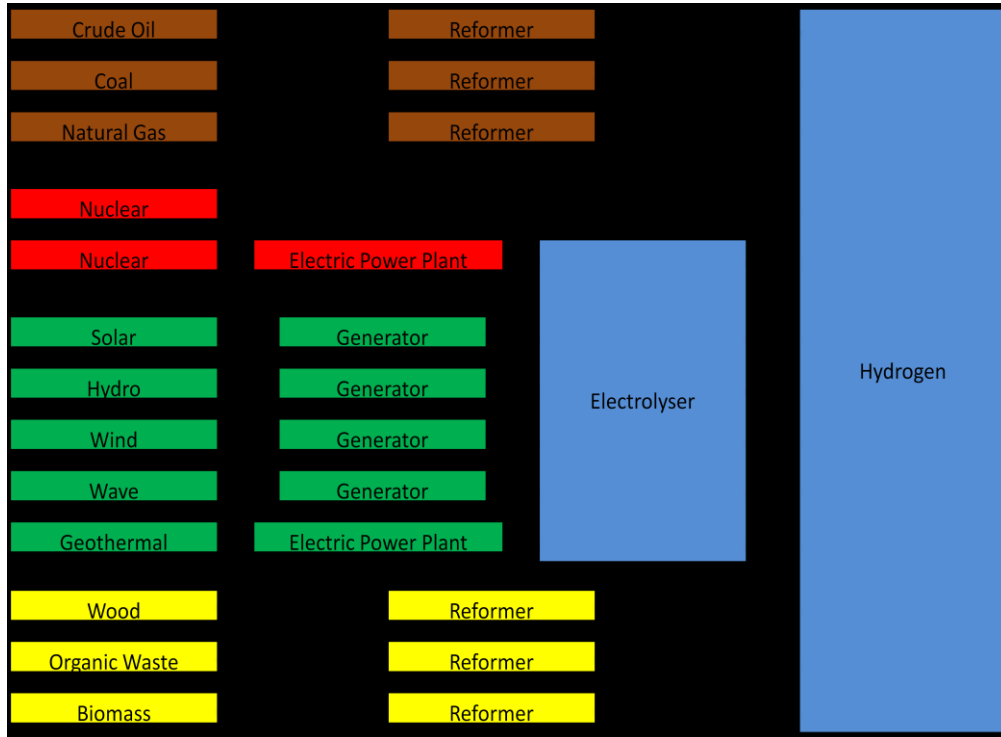

Figure 3: A summary of the current technologies available to produce Hydrogen [40]

### **1.2.3 Fuel Cell Technology**

A fuel cell is an electrochemical device that converts a source fuel into an electrical current. There are various source fuels that can be utilised in fuel cells at specific temperatures using specific materials. Hydrogen is the most commonly used source fuel for fuel cells. This produces water as the only by-product of the electrical current.

There is some controversy as to who first discovered the fuel cell. According to the Department of Energy of the United States of America (US DoE), it was the German chemist Christian Friedrich Schönbein in 1839 who first carried out research on the phenomena that is a fuel cell [10]. There is also very strong evidence that Sir William Robert Grove discovered the concept of fuel cells by immersing two platinum (Pt) electrodes (as anode and cathode) on one end in sulphuric acid and the other ends in sealed containers of Hydrogen and Oxygen gas. A constant current flowed and the level of water in the tubing increased as a result of the Hydrogen and Oxygen being consumed. Grove then discovered by combining the electrodes in series produced a higher voltage drop, thus creating what he called a gas battery i.e. the first fuel cell [41].

Between 1836 and 1862, Schönbein sent letters to Michael Faraday containing information on how their own researches were progressing. Most importantly in these letters, Schönbein stated that he could not conceive how Grove had managed to produce power through the oxidation of a positive electrode [41].

In early 1933, Dr Thomas Francis Bacon developed the first fuel cell for practical and commercial use. It converted Hydrogen and air to electricity through electrochemical processes. Through his work in fuel cells, Bacon created the first fuel cells to be used on British submarines during World War II. In 1958, he developed the first Alkaline Fuel Cell (AFC) [42] and Bacon's fuel cells were so reliable that the company Pratt and Whitney purchased the patents from Bacon and used these fuel cells in NASA's Apollo spacecraft [10, 41].

Since then, the development of fuel cells has moved on at a great pace and they are still seen as efficient and clean power sources as their only waste product is water. For example, PEMFCs operate by passing Hydrogen gas through the anode side of the electrolyte, where Hydrogen ions are transferred through the electrolyte membrane to the cathode (Figure 4). Simultaneously air is passed through the cathode side of the electrolyte, and the negative ions cannot pass through the electrolyte to the anode, so they are dissipated as an electrical current. On the cathode side the Hydrogen and oxygen ions react to form water, which is removed from the fuel cell [10].

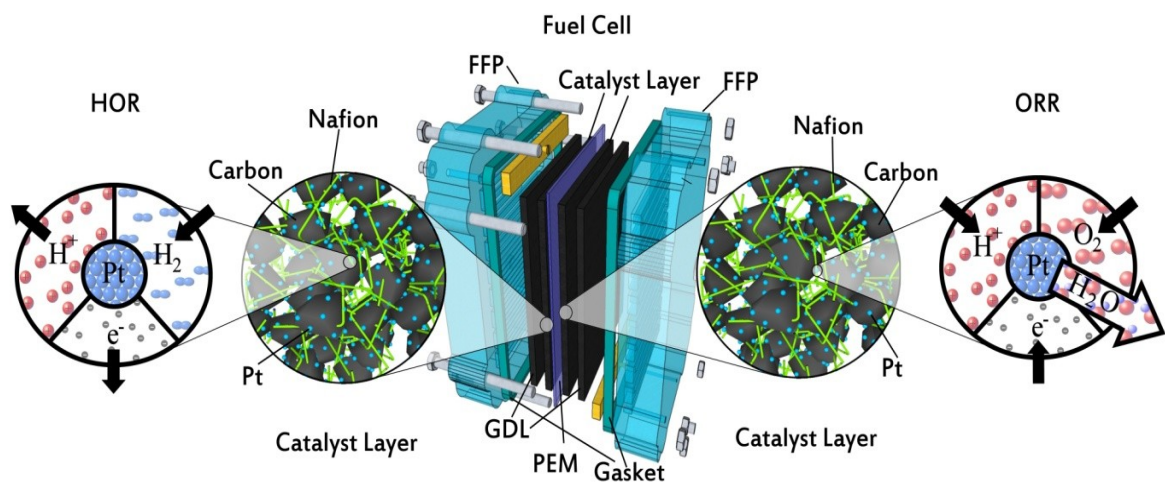

Figure 4: Diagram of a PEMFC [43]



### 1.2.3.1 Summary of Fuel Cells

There are different types of fuel cells. The table below illustrates the various types of fuel cells and their important properties (Table 1).

Fuel Cell Type		Electrolyte	Operating Temperature	Electrical Efficiency	Fuel/Oxidant
AFC	Alkaline Fuel Cell	Potassium Hydroxide Solution	Room temperature to 90°C	60-70%	H <sub>2</sub> / O <sub>2</sub>
PEMFC	Proton Exchange Membrane Fuel Cell	Proton Exchange Membrane	Room temperature to 80°C	40-60%	H <sub>2</sub> / O <sub>2</sub> , Air
DMFC	Direct Methanol Fuel Cell	Proton Exchange Membrane	Room temperature to 130°C	20-40%	CH <sub>3</sub> OH / O <sub>2</sub> , Air
PAFC	Phosphoric Acid Fuel Cell	Phosphoric Acid	160-220°C	55%	Natural gas, Biogas, H <sub>2</sub> / O <sub>2</sub> , Air
MCFC	Molten Carbonate Fuel Cell	Molten mixture of alkali metal carbonated	620-660°C	65%	Natural gas, Biogas, coal gas, H <sub>2</sub> / O <sub>2</sub> , Air
SOFC	Solid Oxide Fuel Cell	Oxide ion conducting ceramic	800-1000°C	60-65%	Natural gas, Biogas, coal gas, H <sub>2</sub> / O <sub>2</sub> , Air

Table 1: Comparison of Fuel Cell Technologies [48]

Direct Methanol Fuel Cell (DMFC) is very similar to PEMFC except it uses methanol as the source fuel instead of H<sub>2</sub>. DMFC has a lower electrical efficiency than PEMFC, but can operate at higher temperatures than its counterpart.

Phosphoric Acid Fuel Cell (PAFC) operates at higher temperatures when compared to PEMFC, and can be utilised using various fuels such as natural gas, biogas and Hydrogen. The PAFC can produce a

significantly higher energy output when compared to the PEMFC; due to the higher operating temperature.

Molten Carbonate Fuel Cell (MCFC) is a high temperature fuel cell that utilises a range of source fuels such as natural gas, biogas and Hydrogen gas ( $H_2$ ). The electrolyte is composed of a molten carbonate salt mixture suspended in a porous, chemically inert ceramic matrix alumina solid electrolyte.

### 1.3 Principles of Electrochemistry

When a metal (M) is dipped into a solution of its ions ( $M^{n+}$ ) an equilibrium such as:

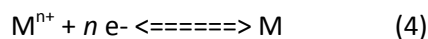

or, generally

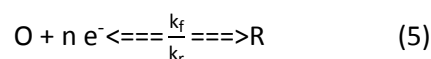

is established at its surface. Such an electrode will adopt a potential difference with respect to the solution whose value is a function of the position of the equilibrium.

Ideally, a redox process is governed by the Nernst equation (Eq.6), which describes the relationship between the electrode potential,  $E_{O/R}$ , and the surface concentration of the O/R redox couple (assuming that the activity coefficients of O and R are unity). The Nernst equation is then:

$$E_{O/R} = E_{O/R}^{\circ} + \frac{RT}{nF} \ln \frac{C_O^s}{C_R^s} \quad (6)$$

where  $R$  is the gas constant in  $J K^{-1} mol^{-1}$  ( $R = 8.3184 J K^{-1} mol^{-1}$  at 298 K),  $T$  is the temperature in K,  $F$  is the Faraday constant ( $96484.6 C mol^{-1}$ ),  $E_{O/R}$  is the working electrode potential in V,  $E_{O/R}^{\circ}$  is the formal redox couple (or Standard Reduction Potential - SRP) in V,  $n$  is the number of electrons transferred per ion or molecule,  $C_O^s$  is the electrode surface concentration of O in  $mol cm^{-3}$ , and  $C_R^s$  is the electrode surface concentration of R in  $mol cm^{-3}$ .

Experimentally, the electrode potential ( $E_{O/R}$ ) cannot be measured. One can only measure a cell potential ( $E_{cell}$ ). This requires a reference electrode e.g. either a Saturated Calomel Electrode (SCE) or a Standard Hydrogen Electrode (SHE).

Thus, by convention, one may write that the cell potential is

$$E_{\text{cell}} = E_{\text{O/R}} - E_{\text{Ref}} \quad (7)$$

If  $E_{\text{Ref}} = 0$

Then,

$$E_{\text{cell}} = E_{\text{O/R}} \quad (8)$$

Here  $E_{\text{cell}}$  is also equal to  $E_{\text{Rev}}$

All galvanic cells are said to operate reversibly when they draw zero current i.e. operate at the reversible potential,  $E_{\text{rev}}$ . However, if the electrode potential is deliberately altered to a value more anodic or cathodic to its equilibrium value, then current will immediately flow in such a direction so as to restore the equilibrium i.e. normal battery discharge or recharge. This perturbation of the electrode potential ( $E_{\text{app}}$ ) is known as the overpotential,  $\eta$ , and is described by Equation 9. The overpotential is usually a deviation of the applied potential,  $E_{\text{app}}$ , from the reversible potential,  $E_{\text{rev}}$ .

$$\eta = E_{\text{app}} - E_{\text{rev}} \quad (9)$$

The kinetic steps found in all electrode processes are:

- (i) Transport of ions from the bulk,
- (ii) Ionic discharge, and
- (iii) Conversion of discharged atom to a more stable form.

The first step gives rise to (a) concentration overpotential ( $\eta_c$ ) while the latter two give rise to (b) activation overpotential ( $\eta_A$ ) i.e. evolution of gases or deposition of metals. In any system there may be a third overpotential called (c) ohmic overpotential ( $\eta_R$ ), which arises due to the depletion of the ions during discharge.

Thus,

$$\eta = \eta_c + \eta_A + \eta_R \quad (10)$$

In general, an overpotential leads to a fall in current and the galvanic cell ceasing to operate.

There are two methods of determining the overpotential of an electrolytic cell. Namely by: (i) the decomposition voltage ( $V_D$ ) and (ii) the discharge potential ( $E_D$ ) methods.

**Method 1: Decomposition Voltage**

A graph of current versus cell voltage gives a decomposition curve and allows decomposition voltages to be determined (Figure 5). The decomposition voltage ( $V_D$ ) is defined as the minimum potential difference, which must be applied between a pair of electrodes before decomposition occurs and a current flows. An experimental value of the decomposition voltage can be obtained by extrapolating the second branch of the curve back to zero current.

The overpotential of the system may be obtained using Equation 11:

$$\eta = V_D - E_{rev}^{cell} \quad (11)$$

where

$$E_{rev}^{cell} = |E_{rev,c} - E_{rev,a}| \quad (12)$$

with  $E_{rev,a}$  and  $E_{rev,c}$  being the reversible potentials of the anode and cathode respectively.

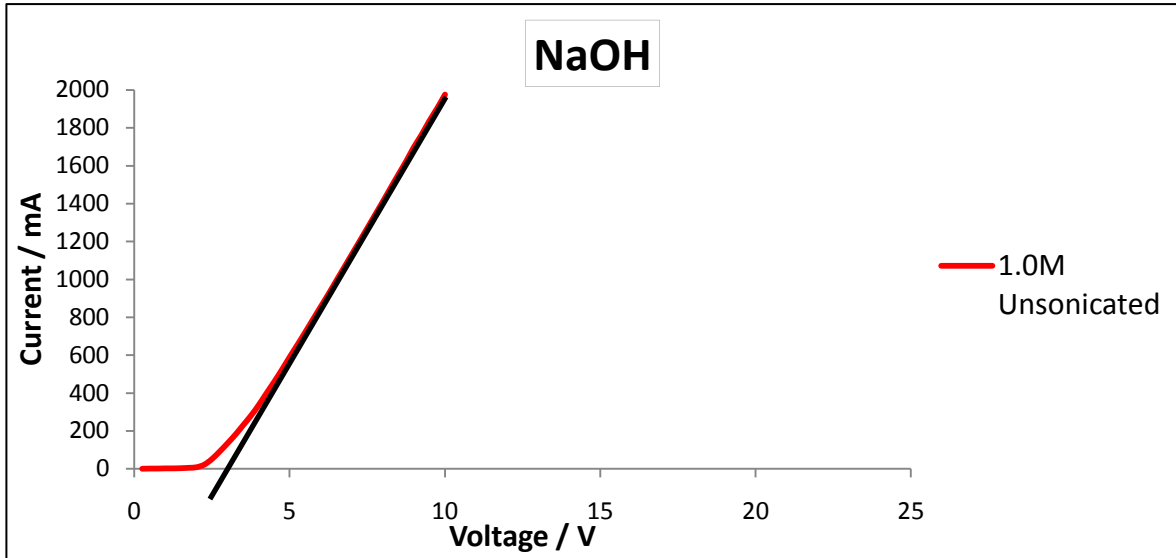

Figure 5: Decomposition Voltage Calculation Demonstration Graph

### Method 2: Discharge Potential

This method requires the study of the electrodes reactions separately potentiostatically. Curves can be plotted for the anode and the cathode separately and, extrapolated to give the respective anodic discharge potential,  $E_{da}$ , and cathodic discharge potential,  $E_{dc}$ . The amount by which the applied electrode potential exceeds the reversible potential,  $E_{rev}$ , for the electrode concerned is the sum of the anode or cathode overpotential  $\eta_a$  and  $\eta_c$  respectively i.e.

$$\eta_a = E_{da} - E_{rev,a} \quad (13)$$

$$\eta_c = E_{dc} - E_{rev,c} \quad (14)$$

Thus, the overpotential of the system may be obtained using the following equation:

$$\eta = \eta_{anode} + \eta_{cathode} \quad (15)$$

where

$$\eta_{anode} = \eta_{A,a} + \eta_{C,a} + \eta_{R,a} \quad (16)$$

and

$$\eta_{\text{cathode}} = \eta_{A,c} + \eta_{C,c} + \eta_{R,c} \quad (17)$$

For the purpose of this work, the overall overpotentials will be calculated by determining the decomposition voltages from current *versus* cell voltage plots (i.e. Method 1) for the following anodic and cathodic reactions occurring at the electrodes:

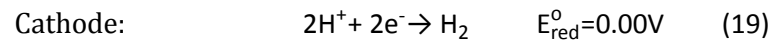
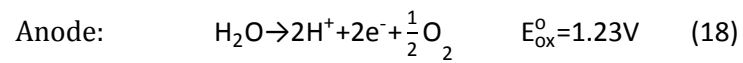

## 1.4 Electrolysis

The actual invention of electrolysis was discovered by van Troostwijk and Diemann using an electrostatic generator in 1789. It was not until 1800 though, that the first usable current source was invented by Volta. This was called the voltaic pile [44]. In the same year two British scientists by the name of Nicholson and Carlisle discovered that water could be split into its constituents by electricity ( $H_2$  and  $O_2$ ). This was performed using brazen electrodes, which resulted in oxide formation on the electrode surface instead of oxygen gas (anode) [44]. Ritter[45] also confirmed this discovery in 1800, but his use of gold electrodes resulted in the formation of oxygen gas on the anode; this was known as the first complete electrolysis experiment. In the 1820s Faraday clarified the principles of electrolysis, although it wasn't until 1834 that Faraday first used the word 'electrolysis' [44].

Gramme[46] invented the *Gramme machine* in 1869, which is an electrical generator that produces direct current. This allowed water electrolysis to be a cost effective method for Hydrogen production [44]. In 1888 a method of industrial synthesis of Hydrogen and oxygen through electrolysis was developed by Lachinov[47].

In 1900 Schmidt presented the first industrial bipolar electrolyser in Zurich. In the same year, Nernst developed the high temperature electrolyte  $ZrO_2$  with 15%  $Y_2O_3$ , which was the basis for solid oxide electrolysis cells and solid oxide fuel cells [48].

Then in 1924, Noegenrath, developed and patented the first ever high pressure electrolysis, and the first  $10,000\text{ m}^3/\text{hr}$  electrolyser was developed in 1939 [10]. However, it was not until 1951 that Lurgi developed the first commercially available high pressure electrolyser operating at 30 bar [49].

After the Second World War in 1948, Eduard Justi and August Winsel developed the first Raney Nickel electrodes which reduced the overpotential suffered by the Hydrogen evolution half reaction in electrolysis [50].



In the 1960s, the National American Space Agency (NASA) commissioned the use of fuel cells for the Gemini-Apollo space program which involved the development of the first polymer cell. The cell was originally made of sulfonated polystyrol, but later modified to use Nafion® instead [12]. Shortly after this in 1966, General Electric (GE) developed the first solid polymer electrolyte and in 1967 [51]. Costa and Grimes developed the first ideas of a 'zero-gap assembly' for electrodes. This was a cornerstone for advanced electrolyser designs [51].

The development of solid oxide electrolyser cells first began in 1972, and then in 1987 the first 100kW electrolyser was built by a Swizz company called ABB [51]. This was the highest H<sub>2</sub> producing electrolyser in its period. The electrolysis of water has been studied since the early 1800s [52]. Initial research was performed on various solvents when mixed with water allowing separation via an electrical current. The electrolytes usually used were dilute sulphuric acid and caustic soda. Special consideration is needed for the material selection depending on the concentration of the acid or base being used in the experiment to avoid erosion of the electrodes.

The rate of decomposition is dependent on the amount of current flowing through the solution. The current however is not directly proportional to the potential difference (cell voltage) of the electrodes. It was also discovered that the volume of gas collected is less than that theoretically calculated and considering this article was written over 100 years ago illustrates how basic the knowledge of electrolysis was then. There is no mention in this article of improving the volumes of Hydrogen and oxygen produced by the cell and the overall efficiency of energy input to energy output in the form of Hydrogen gas.

More recently academics have been investigating ways of cutting energy costs during electrolysis with increasing output of Hydrogen gas. Unlike in Richards [52], there is now a large emphasis on reducing global warming by using pollution free methods of producing energy. The cost of producing

Hydrogen by electrolysis at the moment is not currently economically viable, so improvements must be made to introduce it on a commercial scale.

Stojic *et al.* [53] states that 4.5-5 kWh/m<sup>3</sup> of Hydrogen gas produced is required and the electricity that provides this is the most expensive form of energy. It also states that ionic activators can be used to decrease the energy input per cubic metre of Hydrogen gas collected. These activators provide the electrodes with more or less electrons to attract the Hydrogen or oxygen at a faster rate and therefore increasing the output of Hydrogen without increasing the energy input.

Barbir [21] demonstrated the ability of fuel cells to operate reversibly. When in reverse function, a fuel cell can act as an electrolyser to produce Hydrogen and oxygen. As described earlier, a fuel cell works by reacting Hydrogen and oxygen to produce water and electricity and Barbir [21] states that if the direction of flow of reactants and products were to change, and a current were applied through the cell instead of removing it, Hydrogen and oxygen gas would be produced.

This process produces very clean Hydrogen (99.999%), but due to the high cost of the electrolyser and its running costs, it is only feasible for demonstration plants or remote areas at the time this article was written.

Gregoriev *et al.* [54] reflects upon the findings by Barbir [21] and states that as the need for electrolysers increases, more PEMFCs will be used. The electrolysers produce the 'purest' Hydrogen gas, which is important in PEMFCs since they are highly sensitive to impurities. Gregoriev *et al.* [54] also predicts that the price of PEM electrolysers will decrease to the levels of alkaline electrolysers in the near future, which at the time of publish was currently the most cost effective method of forming Hydrogen gas by electrolysis.

## 1.5 Sonoelectrochemistry

In this study, it was proposed to use ultrasound combined with electrochemistry (Sonoelectrochemistry) for the production of Hydrogen. Sonoelectrochemistry is defined as a branch of electrochemistry which studies any electrochemical processes that are affected, assisted or promoted by power ultrasound [42]. Reports (in the form of papers, patents etc) on the subject have been examined from over the last 100 years to the present day to understand how this area of research has evolved.

During operation, the collection of bubbles on electrode increases electrical resistance of the cell. Ultrasonic irradiation causes “cavitation” of bubbles on electrode surfaces; these bubbles then coalesce to form larger gas bubbles that then implode and collapse, thus releasing dissolved gases (degassing effect). This results in an increase in active sites on the electrode and hence increases the electrical efficiency and yield of the cell [55].

Ultrasound is a sound wave with a high pitch that cannot be heard by the human ear (>16kHz) [56]. Above that frequency, the use of ultrasound in chemistry (Sonochemistry) is divided into two categories: high frequency or diagnostic ultrasound, and low frequency or power ultrasound. High frequency or diagnostic ultrasound operates at frequencies of 2 -10 MHz and is mainly used for medical applications. Low frequency or power ultrasound operates at frequencies of 20 kHz – 2 MHz and this is where the cavitation phenomenon occurs [57, 58].

The term ‘sonicated’ is used to describe when a fluid is subjected to power ultrasound and cavitation bubbles are produced. The cavitation bubbles produced from the ultrasound undergo very violent collapse within the fluid generating ‘hotspots’ of high energy within the fluid [59]. The temperatures produced are up to 5000°C and pressures of up to 2000 atmospheres. This leads to jets of liquid of high velocity of up to 50 m.s<sup>-1</sup> and radical formation (mainly OH• and H•) within the fluid.

There are several areas where Sonoelectrochemistry is currently employed. This includes water and soil remediation, which involves the destruction of bacteria and organics and removal of heavy metals. There is also crystallisation and precipitation of organic and inorganic compounds, polymerisation, nanoparticle production, impregnation of various materials surface treatment and preparation for activation and modification prior to plating and electroplating/electro-deposition, metal finishing and precision engineering [60].

Although this field has received much attention over the past decade, the application of ultrasound in electrochemistry dates back to 1934, by the work of Moriguchi [61]. Nearly 30 years later, Nyborg *et al.* [62] used electrochemical techniques to study acoustic streaming processes using acoustically oscillated electrodes and arrays of electrodes [62]. Since this time several advances in technology have enabled sonoelectrochemistry to be exploited more extensively [63-66].

Up until this time, there was no standardised experimental arrangement for research in this field, until Zang and Coury first recorded a common experimental arrangement for the investigation of sonoelectrochemical effects in 1993 [63]. Hagan and Coury investigated mass transfer effects of an operating ultrasonic horn placed above an electrode [66]. This standard arrangement of experimental apparatus was adopted by fellow academics and developed important refinements to the operation and geometries employed [59, 64, 67, 68]. These studies have attempted to use ultrasound to investigate 'cavitation' processes and the physical and chemical phenomena associated with cavitation.

The term sonolysis describes the breaking of chemical bonds and formation of radicals by ultrasound and examples of the phenomena caused by ultrasound are shown in Figure 6 [69].

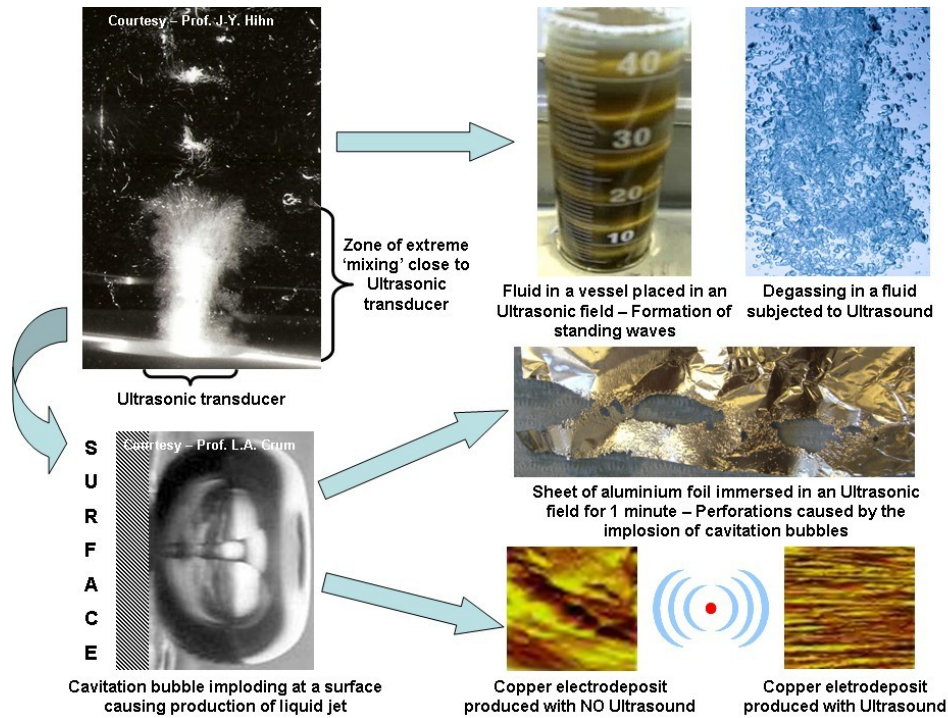

Figure 6: Schematic of Ultrasonic Phenomena [69]

The use of microelectrodes to investigate single cavitation events were carried out by Birkin *et al.* [70, 71] under a range of different experimental conditions. The size of the microelectrodes employed in this study allowed this technique to resolve individual cavitation events and investigate the associated mass transfer effects. Afterwards, Birkin *et al.* [77] developed an electrode with the ability to detect single erosion events associated with inertial (transient) cavitation. An accurate control of the position (to within 10 microns) of the microelectrode with respect to the ultrasonic horn was advocated from this and subsequent studies [72, 73]. Also, consideration of the shape of the pressure-distance profile expected for such an ultrasonic source was suggested [73].

Maisonhaute *et al.* [74] have also studied cavitation by using microelectrodes and reported multiple recurring events under specific conditions of ultrasonic source to electrode separation [74]. It is suggested that these events were associated with a hemispherical bubble on the surface of the electrode by Maisonhaute *et al.* [74].

The ultrasonic field developed by the ultrasound source is fundamental to the cavitation process [73, 75]. Gas bubbles within liquids subjected to sound waves behave in a complex and nonlinear manner. The most common way of dealing with the complexity of possible bubble behaviours is to describe the bubble behaviour as either inertial or non-inertial. Generally, bubbles will vibrate when subjected to an external acoustic field.

The 'inertial/non-inertial' terminology originates from the physics of the collapse phase of this pulsation i.e. if the inertial forces dominate during the collapse (the inertia of the converging liquid), then the collapse is 'inertial'. If instead the pressure forces dominate during the collapse (these act through the stiffness of the gas within the bubble), then the collapse is termed 'non-inertial'.

Even though this definition encapsulates the physics of the process, Sonoelectrochemical researchers are more familiar with differences in phenomena between multi-bubble systems and single bubble [76] experiments. It is inertial cavitation which is associated with most of the effects which researchers are interested in. The effects produced include the generation of radicals [75, 77-79], unusual chemistry (high temperatures and pressures produced by cavitation), the emission of light pulses (termed multi-bubble sonoluminescence) and the erosion of surfaces [73, 80].

The distinction between inertial and non-inertial cavitation is a threshold, primarily defined by the acoustic pressure amplitude, the acoustic frequency and the size of the bubble before the sound field was imposed. It also depends on other parameters, such as surface tension and viscosity, but these are rarely considered as control variables because the common scenario is to control the amplitude and frequency of the sound field rather than adjusting the liquid properties. Note that if there is no bubble already present, then the relevant threshold is one relating to the nucleation of that bubble.

Understanding the behaviour of gas bubbles within a liquid is vital to the interpretation of any sonoelectrochemical experimental data obtained. However, little attention has been focussed on the effect of the electrode itself on the pressure field developed by the operating ultrasonic horn. While

one assertion is that the electrode has a negligible effect on the ultrasound field [81], the theoretical evidence presented here suggests that the electrode is invasive to the sound field.

The presence of the electrode therefore alters the pressure field which can change the behaviour of the bubbles present in the liquid and hence the interpretation of the experimental results.

## 1.6 Sonoelectrochemical Production of Hydrogen

Cataldo [82] was the first researcher to measure the yields of gases released at the electrodes during electrolysis under the action of ultrasound (30kHz frequency and acoustical intensity of 1-2 W.cm<sup>-2</sup>). More specially, the yields of Hydrogen and chlorine during the electrolysis of sodium chloride (NaCl) and hydrochloric acid (HCl) were investigated and quantitative results on the use of ultrasound to the electrolysis process were studied.

These results show that ultrasound dramatically increases the yield of chlorine gas produced from the anode in the electrolysis of NaCl and HCl. Cataldo [82] states that the most important phenomena, produced during sonication, is a strong degassing effect resulting in improved bubble coalescence of gas bubbles. Cataldo [82] also adds the subsequent mechanical removal of bubbles from the electrode surface improved the yield of Hydrogen gas and chlorine gas produced.

Walton *et al.* [83] investigated the use of sonoelectrochemistry (28kHz frequency) for Hydrogen gas evolution using platinum electrodes and aqueous solutions, such as 1.0M sulphuric acid (H<sub>2</sub>SO<sub>4</sub>), 1.0M sodium chloride (NaCl) and hydrochloric acid (HCl). The results produced by Walton *et al.* [83] demonstrated that ultrasound has a positive effect on the electrolysis system, by increasing rates of Hydrogen and chlorine gases evolution at the electrodes (cathode and anode respectively).

It was also discovered that whilst electrolysing 1.0M H<sub>2</sub>SO<sub>4</sub> solution, the oxygen evolution rate at the anode was not enhanced by sonication. Whereas, the electrolysis of NaCl and HCl solutions, the formation of chlorine gas at the electrode was enhanced by the application of ultrasound to the overall system. This is ideal for systems where chlorine gas (Cl<sub>2</sub>) is the preferred anodic product rather than the oxygen gas (O<sub>2</sub>) [83].



McMurray *et al.* [84] extended the research by using of a titanium sonotrode into the sonoelectrolytic system. The use of graphite electrodes and  $0.7\text{mol.dm}^{-3}$   $\text{Na}_2\text{SO}_4$  was also employed. Their findings showed that power ultrasound (20kHz frequency and  $26\text{ W.cm}^{-2}$  ultrasonic power) significantly increases the rate of oxygen and Hydrogen evolution. Furthermore, the Oxygen Reduction Reaction (ORR) rate increased with enhanced mass transport under sonication.

A more significant rate increase was observed for the Hydrogen Evolution Reaction (HER) as a result of lowered activation overpotential ( $\eta_a$ ) for Hydrogen formation on graphite electrodes. McMurray *et al.* [84] concluded that the activation overpotential for Hydrogen evolution can be reduced by sonication via the use of a sonotrode. At the time, it was highlighted that this could be useful as means of increasing gas efficiency by electrolysis.

Budischak *et al.* [85] was one of the first researchers to measure the electroanalytical effects of the HER from potassium hydroxide (KOH) solution. This was achieved by using Linear Sweep Voltammetry (LSV) and Chronoamperometry (CA) to analyse the influence of ultrasound (42kHz) on the electrochemical reactions.

It was shown that ultrasound improves the electrolysis efficiency, especially at intermediate current densities. Even after factoring in, the power required from the sonicator, Budischak *et al.* [85] demonstrated that ultrasonic irradiation could improve the overall efficiency of the system (ratio of input electrical current to Hydrogen produced from the system – see later). Budischak *et al.* [85] also state that the use photoelectrochemical cells could benefit from this effect.

Sasikala *et al.* [86] studied the decomposition of water to Hydrogen and oxygen in the presence of ultrasound (40kHz frequency and 200W power) by suspending solid particulates in the solution. This resulted in an increase in the number of cavitation bubbles created by sonication. It was found that a suitable balance of suspended particles and methanol ( $\text{CH}_3\text{OH}$ ) additionally added to the solution

increased the yield of Hydrogen gas produced. It was found that even with decreasing size of the particles in suspension, the yield of Hydrogen gas produced also increased. It is understood that the particles had a larger surface area and therefore more active sites to create cavitation bubbles, which is why the yield of Hydrogen increased.

The most recent article observed in this review, Li *et al.* [87], discuss the advantages of applying an ultrasonic field (60kHz frequency and 50W ultrasonic power) to water electrolysis on the production of Hydrogen gas. In the article, they showed that by lowering the cell voltage ( $V_{\text{cell}}$ ), an increase in efficiency and a decrease in energy consumption of Hydrogen gas were observed. In this work, the cell voltage was reduced by increasing the current density and by lowering the electrolyte concentration. This resulted in an increase in Hydrogen production, and decreased the energy consumption of the system. Li *et al.* [87], also showed that varying the current density and concentration of the electrolyte had little effect on the rate of  $\text{O}_2$  production from the electrolysis cell.

Whereas in previous research it was shown that ultrasound enhances mass-transfer of electro-active species from the bulk solution to the electrode surface in any electrolytic systems, this research aims to quantify the change in hydrogen gas evolution at the cathode. Research has shown that ultrasound mechanically removes gas bubbles on the electrode surface, thus lowering the so-called 'bubble' overpotential. Therefore the use of ultrasound in an electrolytic solution would be expected to increase the rate of Hydrogen production.

## 2. EXPERIMENTAL METHOD

All Sonoelectrochemical experiments were carried out using either a glass beaker or a custom designed laboratory Sonoelectrochemical cell (Figure 7). The cell consisted of a reaction vessel (diameter 10cm, height 11cm, volume 864 cm<sup>3</sup>) surrounded by an outer vessel, providing a continuous flow of water at 298 K (Tecam Water Bath & Techne Tempette TE-8A Heating Bath Circulator) to regulate a constant temperature in the inner vessel. Two carbon electrodes (active area 7.61 cm<sup>2</sup>) were inserted into the inner vessel and an electrical current was passed through these electrodes to the aqueous solution. Gases produced were collected and measured by water displacement using a glass cylinder.

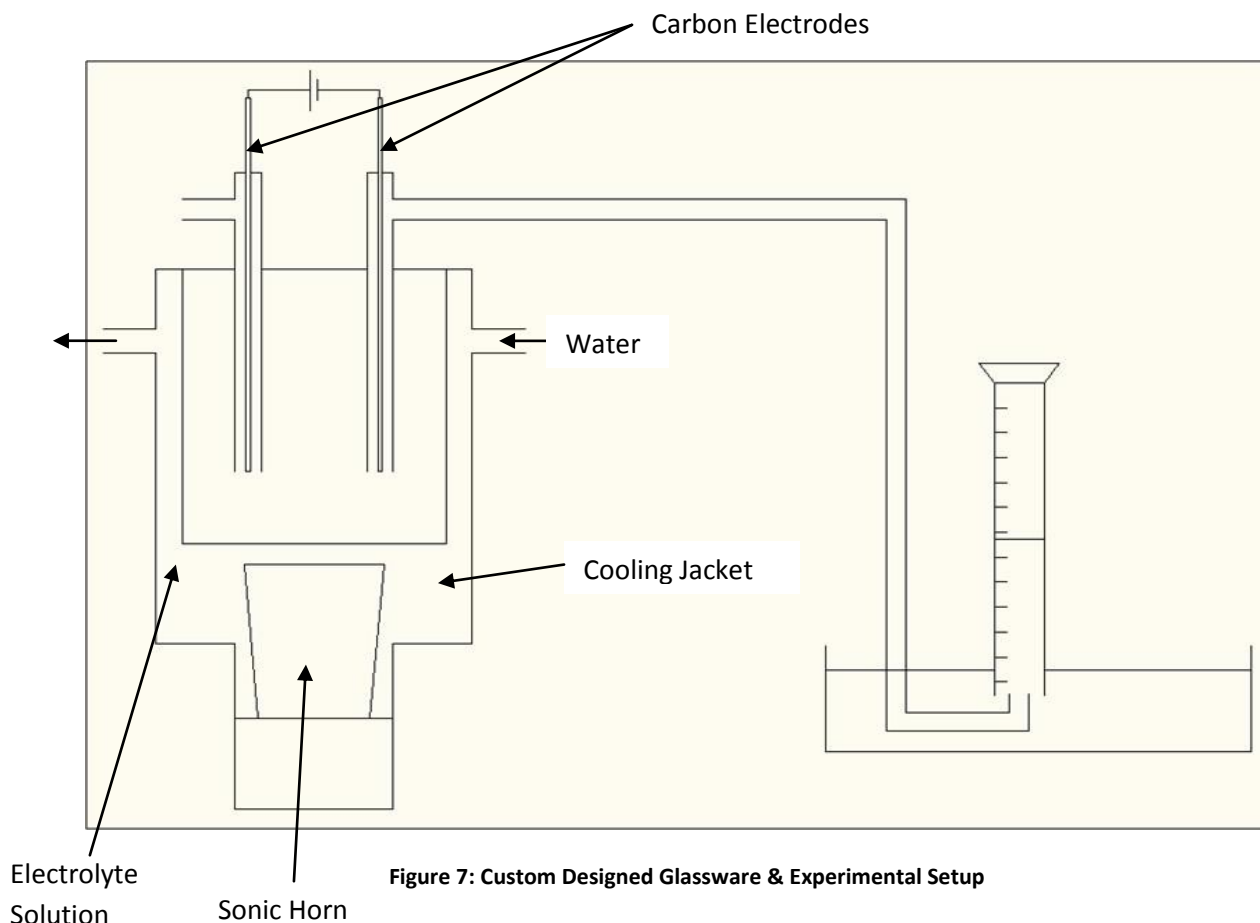
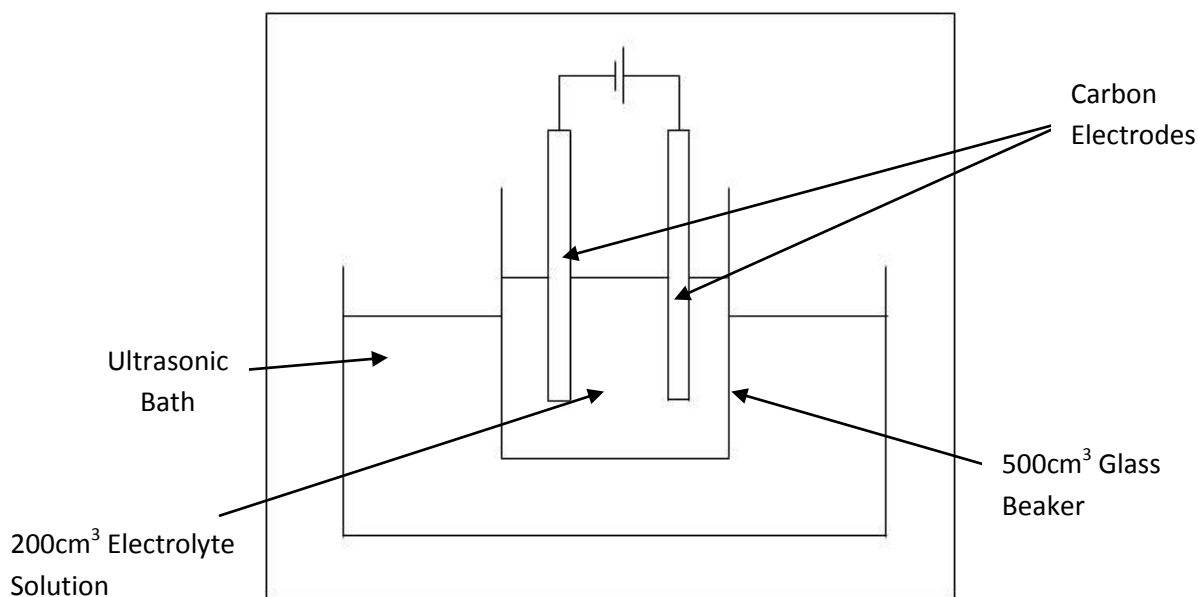

Figure 7: Custom Designed Glassware & Experimental Setup

Three aqueous solutions, namely, sodium hydroxide (NaOH), sodium chloride (NaCl) and sulphuric acid (H<sub>2</sub>SO<sub>4</sub>) were investigated as electrolyte solutions. Cell voltages were applied across the carbon

electrodes immersed in various electrolyte concentrations:  $0.1 \text{ mol.dm}^{-3}$ ,  $0.2 \text{ mol.dm}^{-3}$ ,  $0.3 \text{ mol.dm}^{-3}$ ,  $0.4 \text{ mol.dm}^{-3}$ ,  $0.5 \text{ mol.dm}^{-3}$  and  $1.0 \text{ mol.dm}^{-3}$ . The resultant currents produced by the electrochemical reactions were then measured and recorded. All of these experiments were carried out under silent and sonicated (20 or 40 kHz) conditions and then compared.

During the commissioning of the Sonoelectrochemical cell, preliminary experiments were performed using a laboratory glassware ( $500\text{cm}^3$  glass beaker) and an ultrasonic bath (Langford Ultrasonics – 3.75l Ultrasonic Cleaning Tank, 40 kHz). In all the experiments, a power supply (Thurlby PL320 32V-2A) was used. This experimental setup is shown in Figure 8.



**Figure 8: Experimental Setup for Preliminary Experiments**

It is important to note that ultrasound creates a temperature rise with time in the electrolyte as a result of 'cavitation' and high agitation effects, and therefore the temperature of the electrolyte needs to be regulated and controlled. This was achieved by using a thermostatic bath operating at preset temperatures. Note that an increase in temperature enhances molecules mobility, in turn increasing reaction rates.

For the preliminary experiments, a volume of 200 cm<sup>3</sup> of distilled water was used to which various electrolyte masses were added (Table 2).

Concentrations / M	Mass of Electrolyte / g		
	NaOH	NaCl	H <sub>2</sub> SO <sub>4</sub>
0.1	0.8	1.16	1.97
0.2	1.6	2.32	3.94
0.3	2.4	3.48	5.91
0.4	3.2	4.64	7.88
0.5	4.0	5.8	9.85
1.0	8.0	11.6	19.7

**Table 2: Preliminary Experimental Electrolyte Masses**

When the customised glassware was commissioned, the total volume of the reaction vessel was 1,000cm<sup>3</sup>. The purpose of the preliminary experiments was to construct current vs. voltage plots, whilst the custom glassware (Figure 7) was commissioned to attain volumetric measurements of the Hydrogen gas produced.

This resulted in the reaction vessel being completely filled with the electrolyte solution and sealed gas tight to ensure that all gas produced at each electrode (cathode and anode) left the vessel through the gas outlet side arms to the measuring equipment. The mass of electrolyte used for these experiments is shown in Table 3.

Concentration / M	Mass of Electrolyte / g		
	NaOH	NaCl	H <sub>2</sub> SO <sub>4</sub>
0.1	4.0	5.8	9.85
0.2	8.0	11.6	19.7
0.3	12.0	17.4	29.55
0.4	16.0	23.2	39.4
0.5	20.0	29.0	49.25
1.0	40.0	58.0	98.5

**Table 3: Custom Glassware Experimental Electrolyte Masses**

Cell voltage vs. current plots enabled the determination of the decomposition voltages ( $V_d$ ) for each electrolyte at various concentrations. From the  $V_d$  values, overpotentials were calculated (see later).

As Hydrogen is mainly produced at the cathode, the electrolyte is displaced by the Hydrogen and this volume can be measured using a measuring cylinder (Figure 7). The Hydrogen rate was calculated using Equation 20.

Time was recorded from the first bubble produced at the cathode until the volume of gas reached a fixed volume, thus enabling the calculation of Hydrogen production rates.

The ability to measure the gas evolution volume enabled measurements of the Hydrogen gas production rate, the efficiency of the Hydrogen production based on the 'ideal gas law' and the energy efficiency (see later).

The Ideal Gas Law  $[(V_{\text{ideal}}) \text{ cm}^3]$  is to be used in this study to calculate the expected volume of Hydrogen gas produced depending on the specific reaction conditions [79]. Calculation of ideal Hydrogen gas volume was calculated using Equation 21.

$$V_{\text{ideal}}(\text{cm}^3) = \frac{Slt}{nF} \times \frac{RT}{P} \quad (21)$$

where  $S$  is the stoichiometric coefficient,  $I$  is the current density ( $\text{mA}\cdot\text{cm}^{-2}$ ),  $t$  is the operating time (seconds),  $n$  is the number of electrons transferred,  $F$  is the Faraday constant ( $96484 \text{ C}\cdot\text{mol}^{-1}$ ),  $R$  is the ideal gas constant ( $8.314 \text{ J}\cdot\text{K}^{-1}\cdot\text{mol}^{-1}$ ),  $T$  is the operating temperature in Kelvin and  $P$  is the pressure in Pascal [79].

The volume of Hydrogen gas produced ideally is then compared with the volume of Hydrogen gas actually produced to calculate the efficiency of the electrolysis reaction. This was calculated using Equation 22 [79]:

$$\text{Efficiency (\%)} = \frac{V_{\text{real}}}{V_{\text{ideal}}} \times 100 \quad (22)$$

The Hydrogen efficiency for each electrolyte concentrations was plotted for silent and sonicated conditions.

## **2.1 Equipment & Parameters**

All experiments were performed in silent and sonicated conditions in views of investigating the effect of ultrasound on Hydrogen production. Ultrasonic irradiation was provided by either an ultrasonic horn (Sonics Ti Alloy, 47mm in diameter connected to a Sonics VCX750 VibraCell operating at 20 kHz and maximum power of 750 W) or an ultrasonic bath operating at 40 kHz. For our experiments at 20 kHz, the ultrasonic power was  $20.7 \text{ W/cm}^2$  unless otherwise stated.

The carbon electrodes used were manufactured by Morganite which had a diameter of 5mm and a length of 300mm. The glassware used for the preliminary experiments was a standard  $500\text{cm}^3$  glass beaker and the custom glassware used was manufactured by Soham Scientific (reference 0210-109e). For all experiments the power was supplied by a Thurlby AC/DC PL320 32V-2A. The potential was varied and the current produced was recorded.

### 3. RESULTS AND DISCUSSION

In this section, all results are presented and discussed.

#### 3.1 Preliminary Experiments

Data presented below were performed using the experimental equipment shown in Figure 8.

##### 3.1.1 Current Voltage Curves

Figure 9 shows current vs. voltage plots of sodium hydroxide solutions for sonicated and silent conditions at various concentrations and at 298 K.

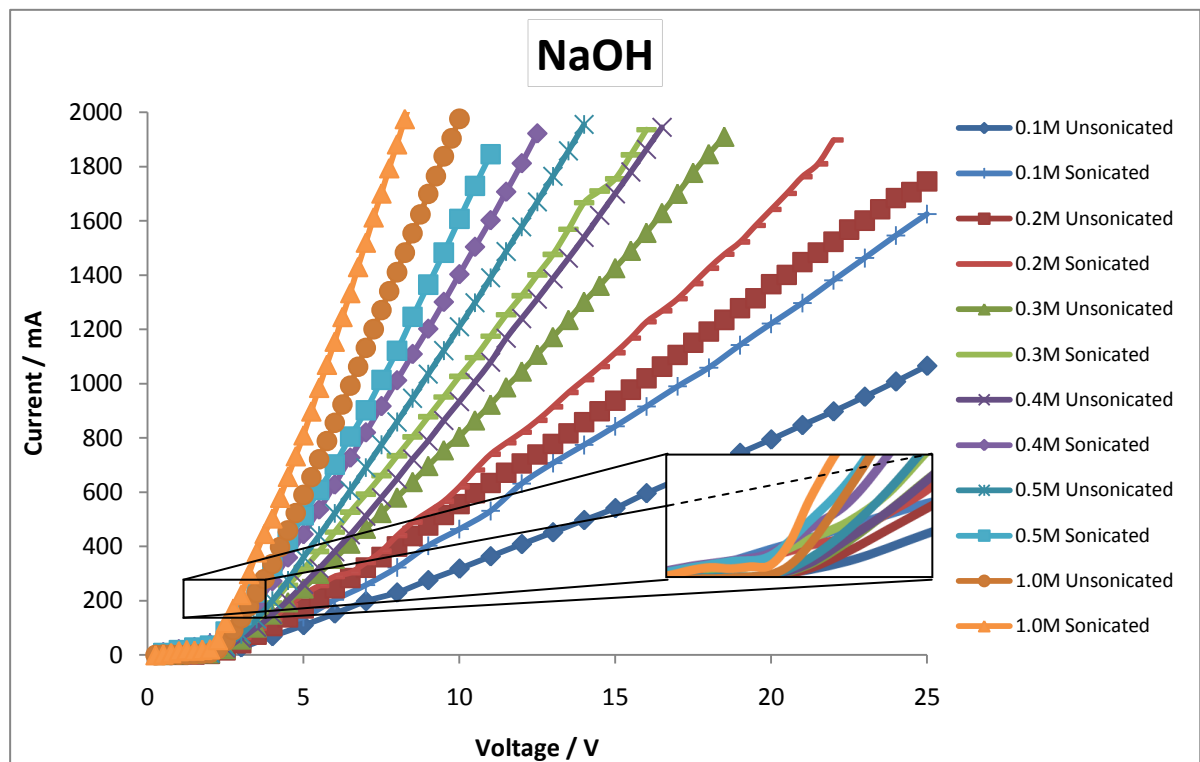

Figure 9: Decomposition Curves for NaOH solution

Figure 9 provides evidence that as the cell voltage is increased, the resulting current increases due to the higher voltage across the cell. This is a result of the increased voltage across the electrolytic solution. Higher electrolyte concentrations lead to large currents, which is to be expected and due to an increased number of charge carriers in the solution. As shown in Figure 9 the introduction of



sonication increases the current further at a fixed voltage. This is a result of increased electron mobility and mass transfer on the surface of the electrode surface.

The sodium chloride current voltage plots for sonicated and silent conditions in various electrolyte concentrations at 298K are shown in Figure 10.

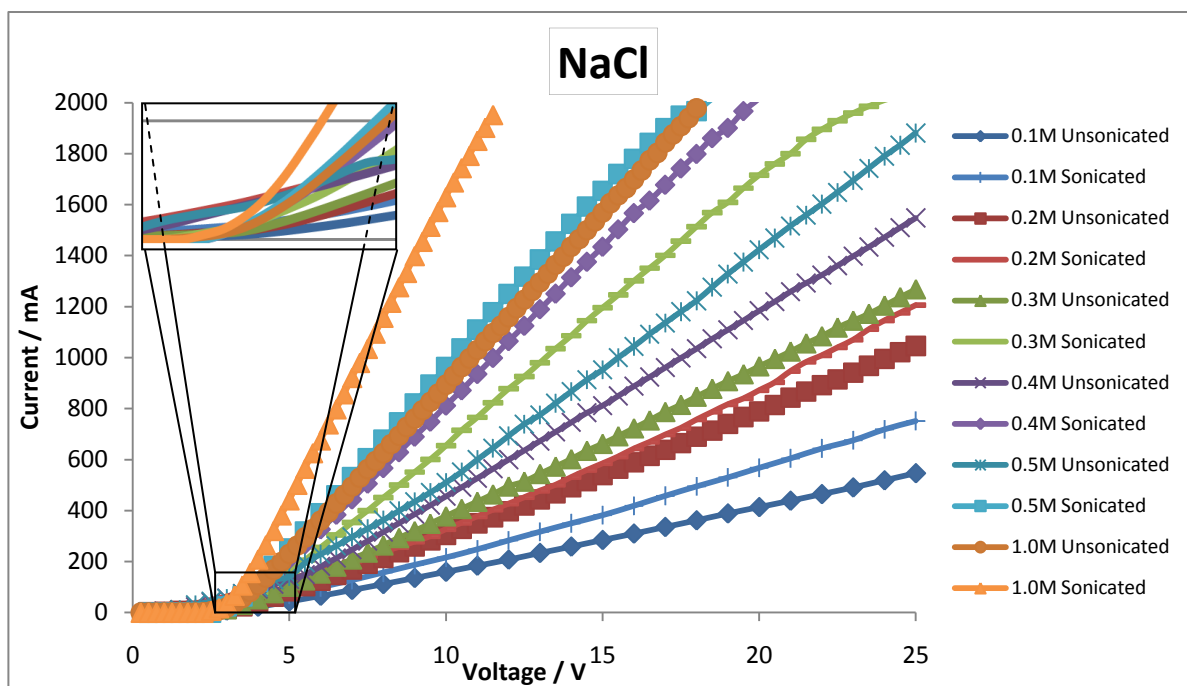

Figure 10: Decomposition Curves for NaCl solution

Figure 10 provides evidence that as the cell voltage is increased, the resulting current increases due to the higher voltage across the cell. This is a result of the increased voltage across the electrolytic solution. Higher electrolyte concentrations lead to large currents, which is to be expected and due to an increased number of charge carriers in the solution. As shown in Figure 10 the introduction of sonication increases the current further at a fixed voltage. This is a result of increased electron mobility and mass transfer on the surface of the electrode surface.

Figure 11 illustrates the electrochemical behaviour for sulphuric acid in silent and sonicated systems at 298K.

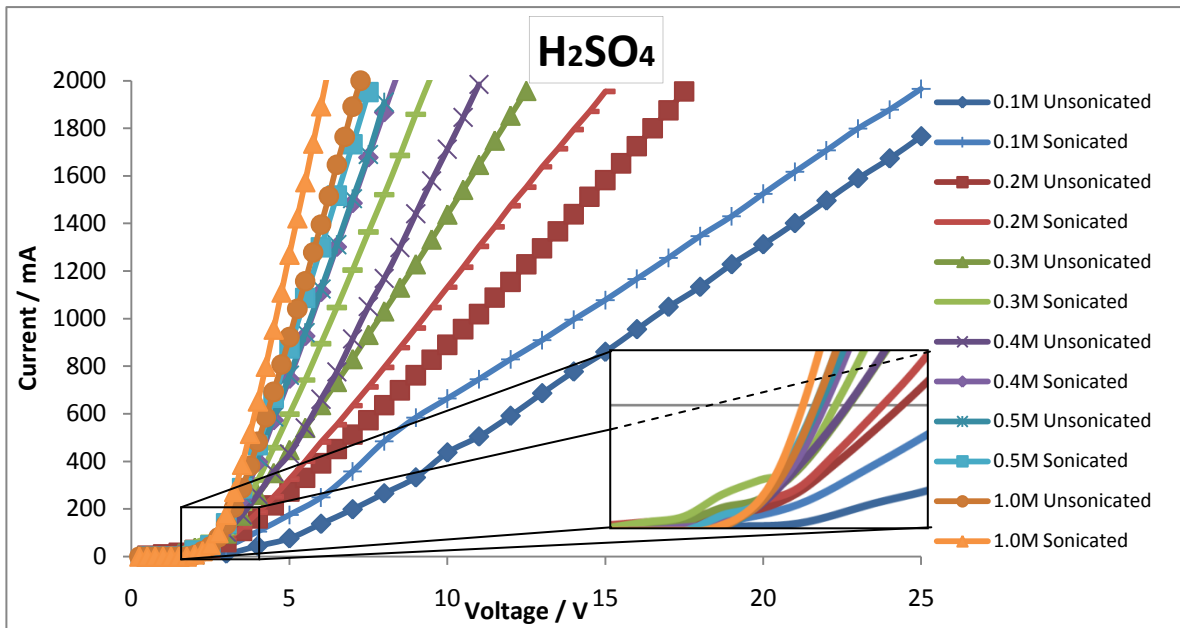

Figure 11: Decomposition Curves for H<sub>2</sub>SO<sub>4</sub> solution

Figure 11 provides evidence that as the cell voltage is increased, the resulting current increases due to the higher voltage across the cell. This is a result of the increased voltage across the electrolytic solution. Higher electrolyte concentrations lead to large currents, which is to be expected and due to an increased number of charge carriers in the solution. As shown in Figure 11 the introduction of sonication increases the current further at a fixed voltage. This is a result of increased electron mobility and mass transfer on the surface of the electrode surface.

Figure 12 shows a comparison for all three electrolytes at 1.0M concentration at 298K.

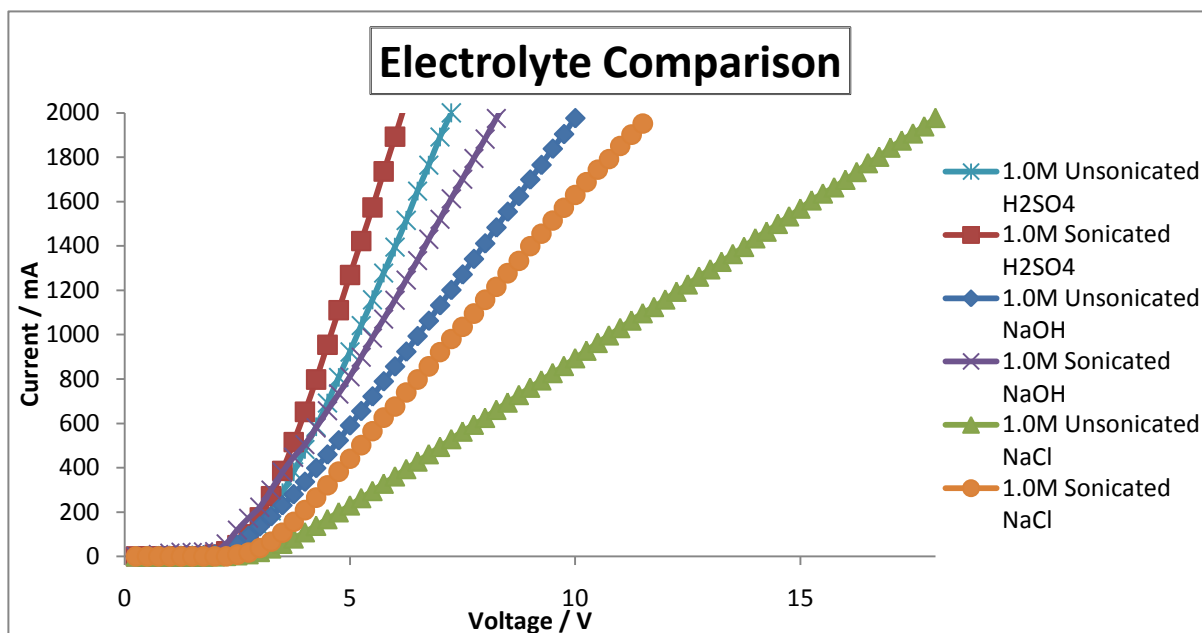

Figure 12: Current Voltage Comparison Graph for all three electrolytes

All three electrolytes have differing electrochemical characteristics as illustrated in Figure 12. It is shown that H<sub>2</sub>SO<sub>4</sub> solution is more electrically conductive than NaOH and NaCl respectively. NaCl displays the most resistance to flow of electrons in the electrolytic solution compared to the other electrolytes. It should be noted however that the use of electrolytes does result in electrode degradation that limits the durability and lifetime of the electrodes (see section 4.3).

Figure 12 also shows that sonication improves the electrical conductivity for all three electrolytes used, but with no overlap of electrolytes in terms electrical conductivity (e.g. no NaCl sonication > NaOH silent).

Conductivity is determined as the rate of current flowing through the solution. Data presented in Figure 93, Figure 94 & Figure 95 in Appendix II, show that as the cell voltage is increased across the cell, the current that flows through the solution increases as expected [79]. The increase is not linear at first, but when the cell voltage is greater than the decomposition voltage, the current increases linearly with the applied cell voltage.

Figure 99, Figure 100 & Figure 101 in Appendix II show that as the concentration of the electrolyte is increased, the corresponding current flowing increases at each cell voltage. This is expected due to the increase in charge carriers i.e. ions in the solution.

Comparing sonicated and silent conditions in Figure 13, Figure 14 & Figure 15, it is evident that the introduction of ultrasound to the system increases the flow of current through the cell. It has been shown ultrasound causes 'extreme' agitation in the solution and produces energetic charges, thus allowing electrons to move more freely i.e. reducing the ohmic resistance in the electrolyte solution.

### 3.1.2 Overpotential Determination

All overpotential calculations and graphs are shown in Appendix III and Table 4 shows the calculated decomposition voltages.

Decomposition Voltages ( $V_d$ )				
Concentration	Sonication?	NaOH	NaCl	H <sub>2</sub> SO <sub>4</sub>
0.1M	Silent	3.2	3.58	5.00
	Sonicated	3.59	3.55	2.73
0.2M	Silent	3.05	3.64	3.12
	Sonicated	3.5	3.76	3.05
0.3M	Silent	3.28	3.52	2.80
	Sonicated	2.98	3.29	3.07
0.4M	Silent	3.53	3.58	3.25
	Sonicated	2.81	3.28	2.96
0.5M	Silent	3.1	3.98	2.93
	Sonicated	2.87	3.88	2.93
1.0M	Silent	2.92	3.33	3.03
	Sonicated	2.77	3.09	2.97

Table 4: Table of Decomposition Voltages

The overpotentials for each experiment is calculated using Equation 8 and are shown in the table below.

Overpotential ( $\Sigma\eta$ )				
Concentration	Sonication?	NaOH	NaCl	H <sub>2</sub> SO <sub>4</sub>
0.1M	Silent	1.97	2.35	3.77
	Sonicated	2.36	2.32	1.50
0.2M	Silent	1.82	2.41	1.89
	Sonicated	2.27	2.53	1.82
0.3M	Silent	2.05	2.29	1.57
	Sonicated	1.75	2.06	1.84
0.4M	Silent	2.30	2.35	2.02
	Sonicated	1.58	2.05	1.73
0.5M	Silent	1.87	2.75	1.70
	Sonicated	1.64	2.65	1.70
1.0M	Silent	1.69	2.10	1.80
	Sonicated	1.54	1.86	1.74

Table 5: Table of Overpotentials

The overall overpotentials for the system for silent and sonicated systems are on average 2 Volts. For each electrolyte, the average overpotential for silent and sonicated systems was calculated and compared. These are illustrated in Table 6 below.

Average Overpotential ( $\Sigma\eta$ )			
System	NaOH	NaCl	H <sub>2</sub> SO <sub>4</sub>
Silent	1.95	2.38	2.13
Sonicated	1.85	2.25	1.73

Table 6: Table of Average Overpotentials

Table 6 shows that the application of ultrasound to the system reduces the average overpotential for each electrolyte as shown above. Figure 12 represents a graphic comparison of the electrochemical behaviour of the three electrolytes. Table 6 reaffirms the data represented in Figure 12 showing that sulphuric acid suffers the least overpotential when compared to sodium hydroxide and sodium chloride, except for one instance.

The average overpotential for sulphuric acid in silent systems would be expected to be less than that of sodium hydroxide, but is in fact 0.18V greater from the data recorded (Table 6).

For 0.1 mol.dm<sup>-3</sup> H<sub>2</sub>SO<sub>4</sub> solution in silent conditions, the overpotential was calculated to be 5.00V. This is 134% greater than the average value for the average sulphuric acid overpotential under silent conditions. This experiment requires several repeats to re-evaluate this observation. If this figure is ignored, the average overpotential for the other H<sub>2</sub>SO<sub>4</sub> concentrations in silent conditions is 1.79V, which is 0.34V less than the value presented in Table 6. This also confirms that sulphuric acid suffers the least overpotential on average when compared to NaCl and NaOH solutions under and sonicated conditions.

There are various types of overpotential that can give 'resistances' to the flow of current through the solution. One of the main contributors is the activation overpotential ( $\eta_a$ ), which is determined by the activation energy ( $E_a$ ) i.e. Gibbs energy. This energy barrier must be overcome before the electrochemical reaction can proceed. These values differ depending on the electrode materials and the particular gas forming on the electrodes. The activation overpotential for Hydrogen forming on carbon electrode is -0.62V, whilst the activation overpotential for oxygen forming on carbon electrode is +0.95V [88, 89].

Other contributors to overpotential include reaction overpotential, which is related to chemical reactions before electron transfer can occur. Concentration overpotential involves the depletion of charge carriers at the electrode surface. A specific example of this is bubble overpotential involving the formation of gaseous bubbles at the cathode and/or anode, resulting in a reduced contact area and therefore an increase in the current density of that electrode. This process can be shown when the electrolysis of sodium chloride forms chlorine on the anode instead of sodium chloride as expected in bubble overpotential. This occurs due to chlorine evolution reaction (Equation 13) on the anode which has a lower activation potential ( $\text{Cl}_2$  formation on Graphite) than that of the oxygen evolution reaction (Equation 23) [90]:

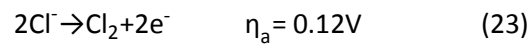

## 3.2 Custom Glassware Experiments

It should be noted that all experiments were carried out only once, so data is subject to unreliability.

Repetition of experiments required to increase reliability of results.

Data presented below was carried out using the equipment illustrated in Figure 7. All sonicated experiments were carried out at 20kHz and 20.7 W/cm<sup>2</sup>.

### 3.2.1 Current-Voltage Curves

The enhancement in current density for varying voltage as a result of the introduction of ultrasound for sodium hydroxide at various concentrations and at 298 K is shown in Figure 13.

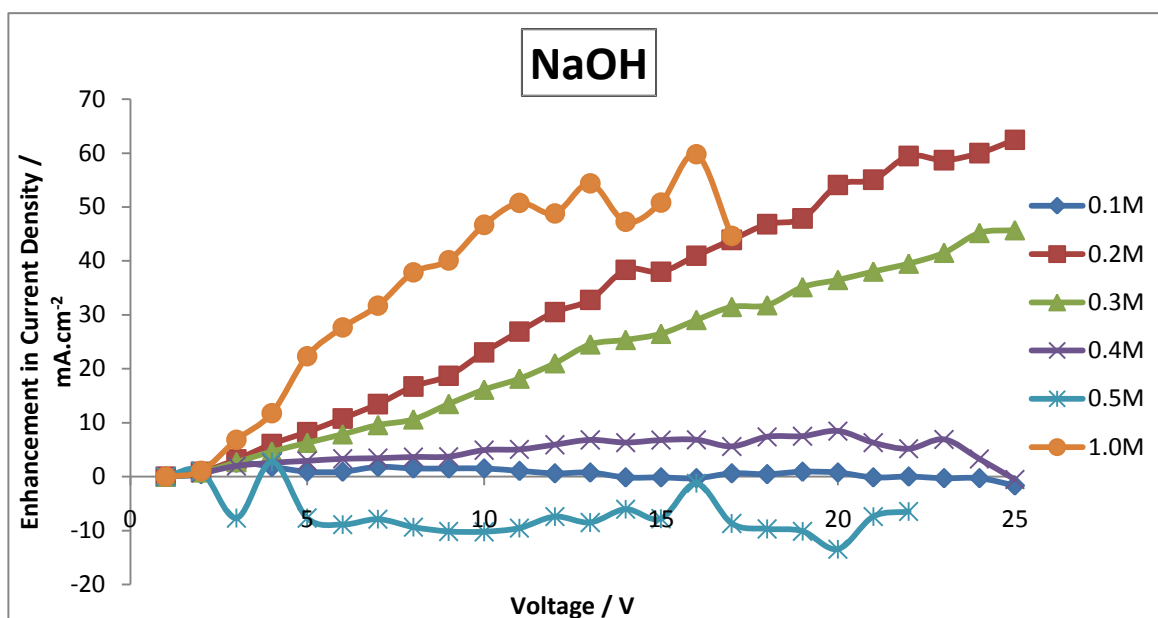

Figure 13: Current Enhancement for NaOH solution

Figure 13 shows an enhancement in electrical conductivity from the introduction of ultrasound to the cell. There is an increase in electrical conductivity as a result of sonication for all but one of the concentrations, 0.5M NaOH. A linear increase for all concentrations would be expected from the extra mobility provided to the charge ions (electrons) by ultrasound caused by high-stirring.



The enhancement in current density at various cell voltages and concentrations for the sodium chloride system under silent and ultrasonic conditions at 298K is shown in Figure 14.

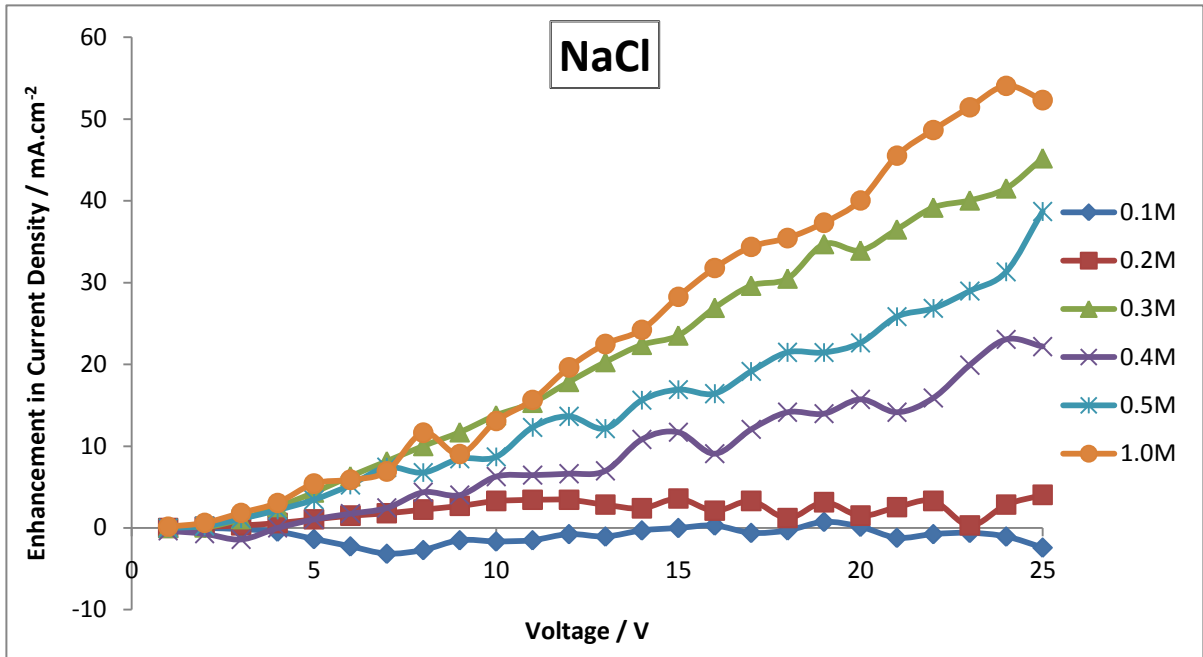

Figure 14: Current Enhancement for NaCl solution

The enhancement from sonication for NaCl is very similar to that of NaOH. All except one of the concentrations show an increase in electron mobility as a result of induced ultrasound.

The enhancement in current density at various cell voltages as a result of sonication for sulphuric acid in several concentrations at 298K is shown in Figure 15.

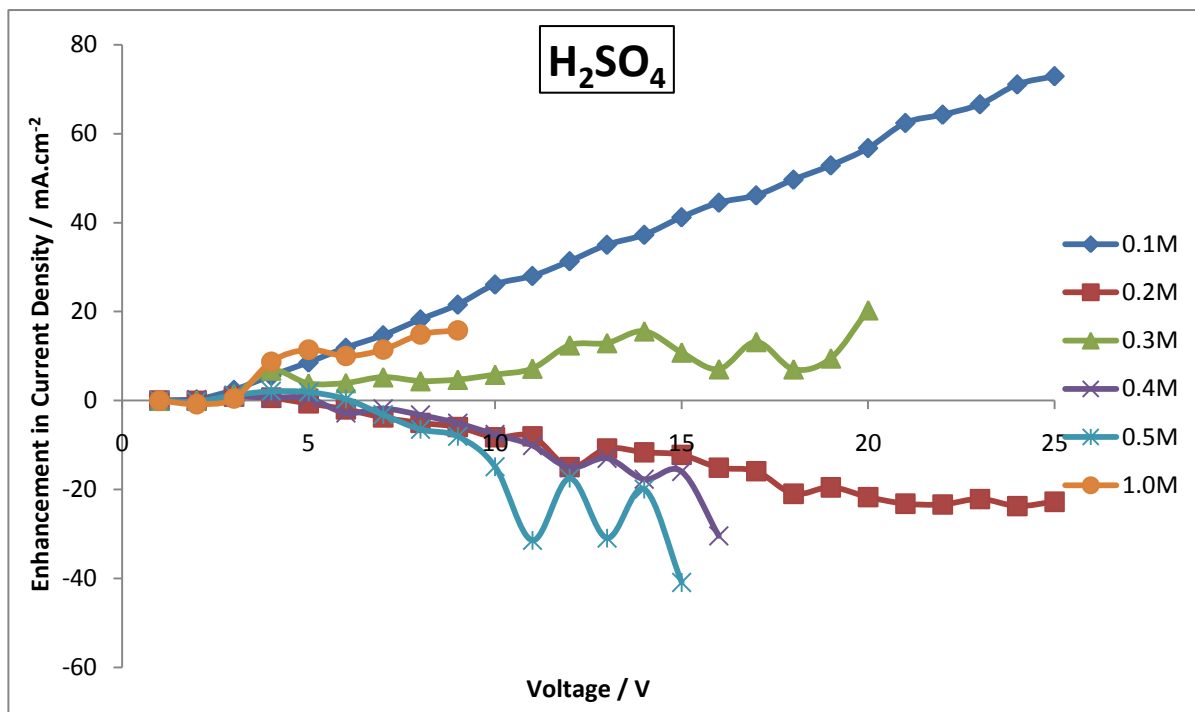

Figure 15: Current Enhancement for H<sub>2</sub>SO<sub>4</sub> solution

Figure 15 shows that there is little correlation for H<sub>2</sub>SO<sub>4</sub> solution from the data presented above. Three concentrations show a positive impact of ultrasound on the system, and the other three concentrations show an opposite trend. Once again careful analysis of these results must be taken since they are subject to reliability issues, due to the fact that these experiments, as of yet have not been repeated.

### 3.2.2 Hydrogen Evolution Rate

Figure 16 shows the enhancement in Hydrogen production at several cell voltages and concentrations for the sodium hydroxide system under silent and ultrasonic at 298K.

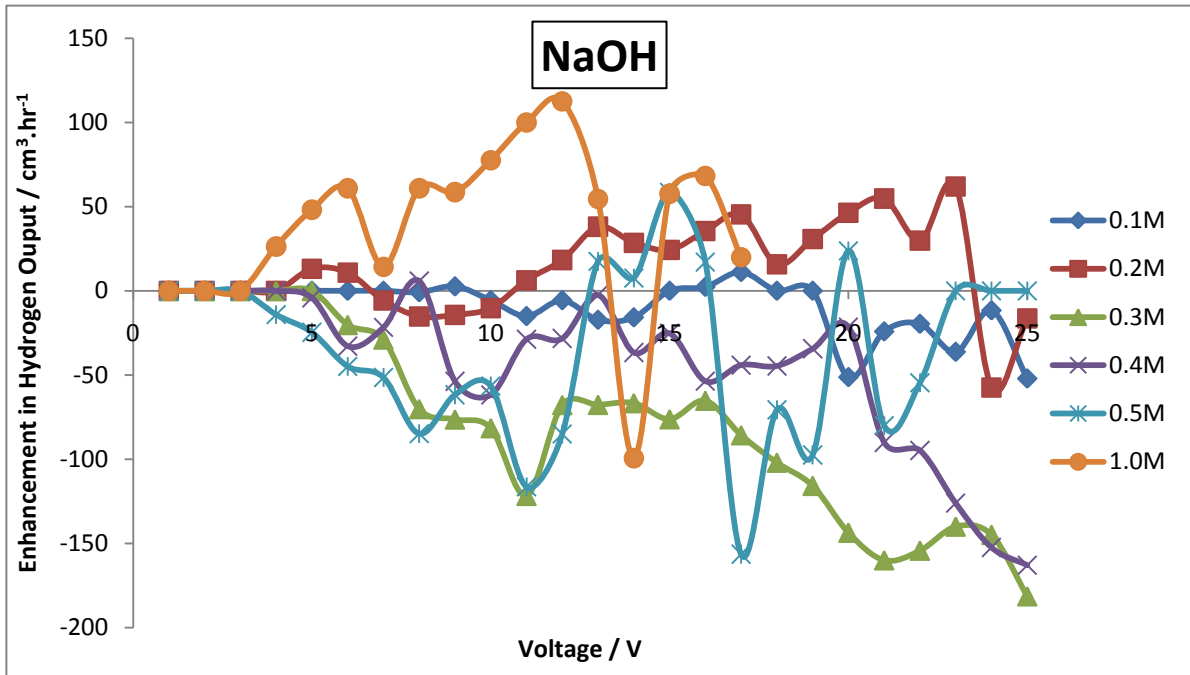

Figure 16: Hydrogen Production Enhancement for NaOH solution

An important criterion of commercial Hydrogen production systems is the productivity of Hydrogen from the system itself. It is expected that an increase in Hydrogen production to occur as a result of the use of ultrasound. Figure 16 shows the effect on ultrasound on the production of Hydrogen to be very poor with little/no cohesion from the data collected. For each concentration electrolyte at some point suffers negative Hydrogen output as a result of sonication.

Figure 17 shows an enhancement in Hydrogen production at several cell voltages as a result of the introduction of ultrasound for sodium chloride in various concentrations at 298K.

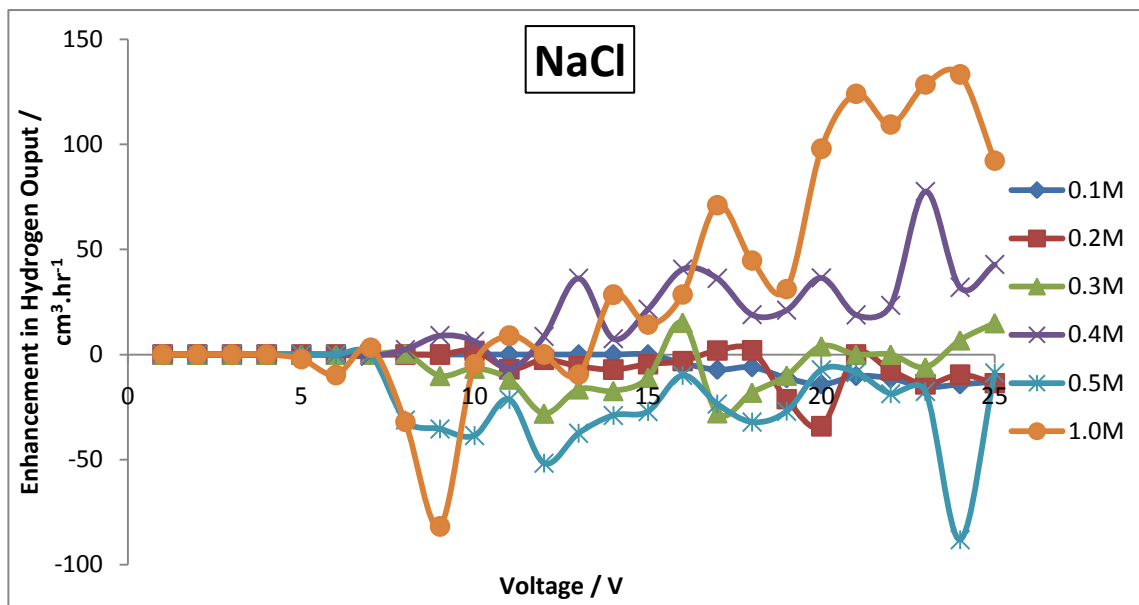

Figure 17: Hydrogen Production Enhancement for NaCl solution

Figure 17 exhibits slightly more cohesive data than those shown in Figure 16. Only 0.4M and 1.0M NaCl solutions show an enhancement in Hydrogen productivity, whilst for the other concentrations of NaCl solutions show a decrease in Hydrogen production as a result of ultrasound. Once again, data has only been recorded only once for these experiments, so is subject to unreliability.

Figure 18 shows the enhancement in Hydrogen production at several cell voltages, at various concentrations and at 298 K for the sulphuric acid system in the absence and presence of ultrasound.

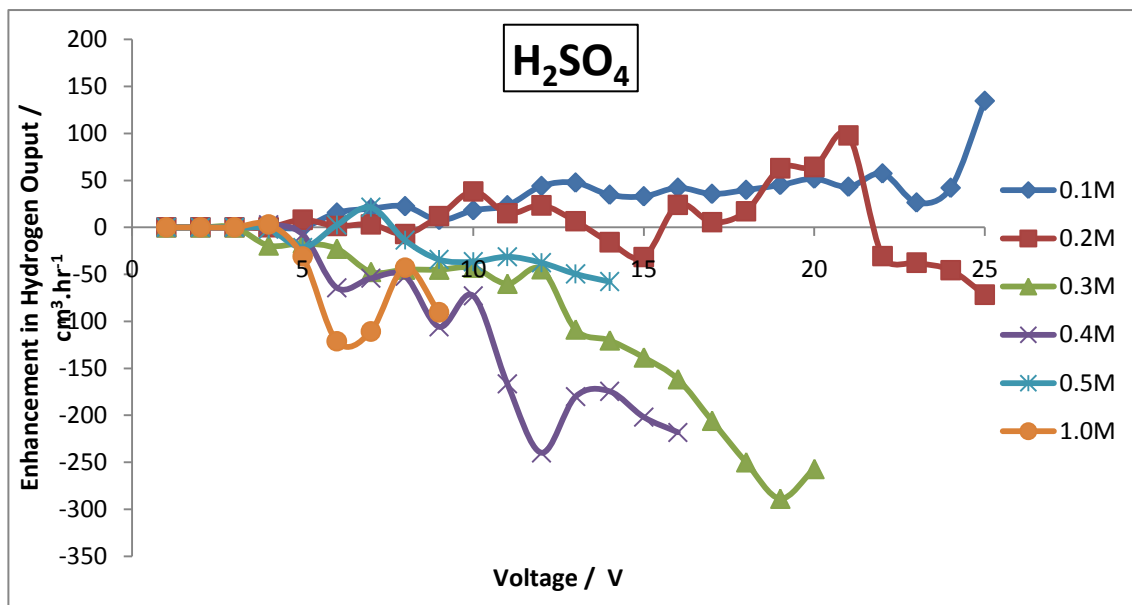

Figure 18: Hydrogen Production Enhancement for H<sub>2</sub>SO<sub>4</sub> solution

Figure 18 shows similar trends to Figure 16 and Figure 17 in that there is no visible increase in Hydrogen production from the use of ultrasound. It would be expected to observe increases in Hydrogen production for all concentrations used at various rates. Most of the concentrations demonstrate detrimental effects in terms of Hydrogen production while only a few show a positive impact.

Hydrogen production, for this investigation, is defined as the rate of which Hydrogen gas is produced from the system. The production of Hydrogen increases with an increase in electrolyte concentration. This is to be expected since there is an increase in number of charge carriers in the solution, resulting in an enhanced mass transfer on the electrode surface induced by ultrasound leading to an increase in Hydrogen production rate [79].

As shown in Figure 16, Figure 17 & Figure 18, the application of ultrasound to the system shows little and even no improvement in the production of Hydrogen from the Sonoelectrochemical cell. From

our observations here, whilst sonication is occurring, fewer bubbles are formed on the surface of the electrodes due to the ultrasonic horn producing sonic waves through the solution. These ultrasonic waves produce a 'force' on the electrodes surfaces, from which limited bubble formation on the electrode surface. This limits the reaction rate of the Hydrogen ions ( $H^+$ ) and electrons ( $e^-$ ) on the cathode surface and whilst the number of active sites is maintained, the ions and electrons have difficulty reacting in the triple phase boundary on the electrode.

The data shown in Figure 16, Figure 17 & Figure 18 are not sufficient to draw any conclusions on whether ultrasound enhances Hydrogen production. The repeatability of the experiments and use of precision equipment, for example a flow meter calibrated to measure Hydrogen gas or better a Gas Chromatographer (GC), instead of a measuring cylinder full of water being displaced by the Hydrogen gas produced, could aid achieving conclusive results.

### 3.2.3 Hydrogen Efficiency Data

Figure 19 shows plots of efficiency enhancements of Hydrogen production at various cell voltages, concentrations and 298 K for the sodium hydroxide system under silent and ultrasonic conditions.

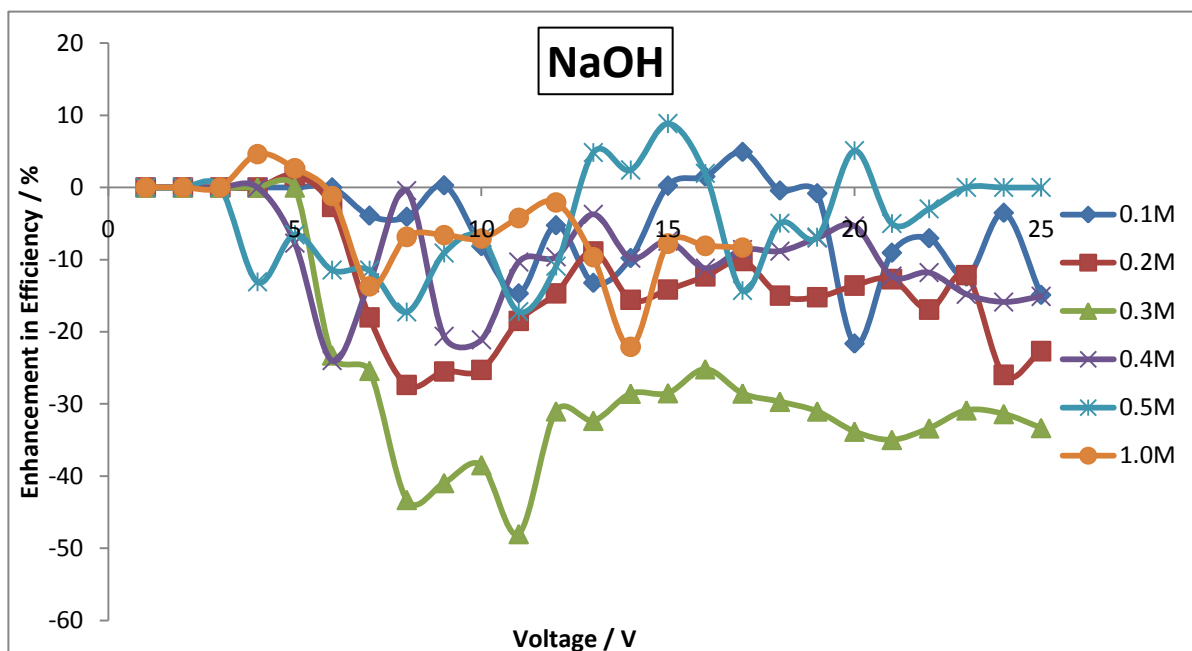

Figure 19: Hydrogen Output Efficiency Enhancement for NaOH solution

Quantifying the efficiency of Hydrogen production is achieved by comparing the actual Hydrogen production with the theoretical Hydrogen production from the ideal gas law (see above). Figure 19 shows a decrease in efficiency for all concentrations of NaOH, as a result of sonication, with the highest loss being approximately 50% for the 0.3M NaOH solution.

Figure 20 shows plots of efficiency enhancements of Hydrogen production at various cell voltages, concentrations and 298 K for the sodium chloride system under silent and ultrasonic conditions.

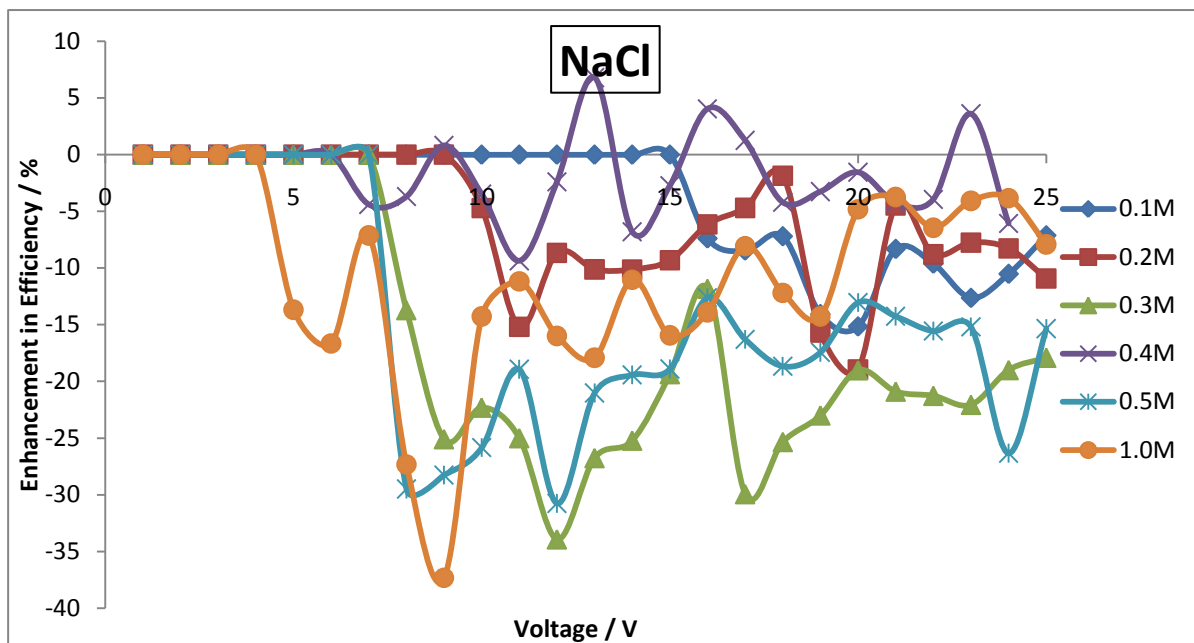

Figure 20: Hydrogen Output Efficiency Enhancement for NaCl solution

Figure 20 follows a similar trend to that in Figure 19, with negative gradients, implying that ultrasound has a detrimental effect on Hydrogen production from electrolysis. 0.4M NaCl solution is the only concentration that exhibits a positive increase in efficiency at any point, from the use of ultrasound. Characterising the results from the data given in Figure 20 is not possible, so further work needs to be carried out on this experimental set up to increase consistency and reliability of data.



Figure 21 shows plots of efficiency enhancements of Hydrogen production at various cell voltages, concentrations and 298 K for the sulphuric acid system under silent and ultrasonic conditions.

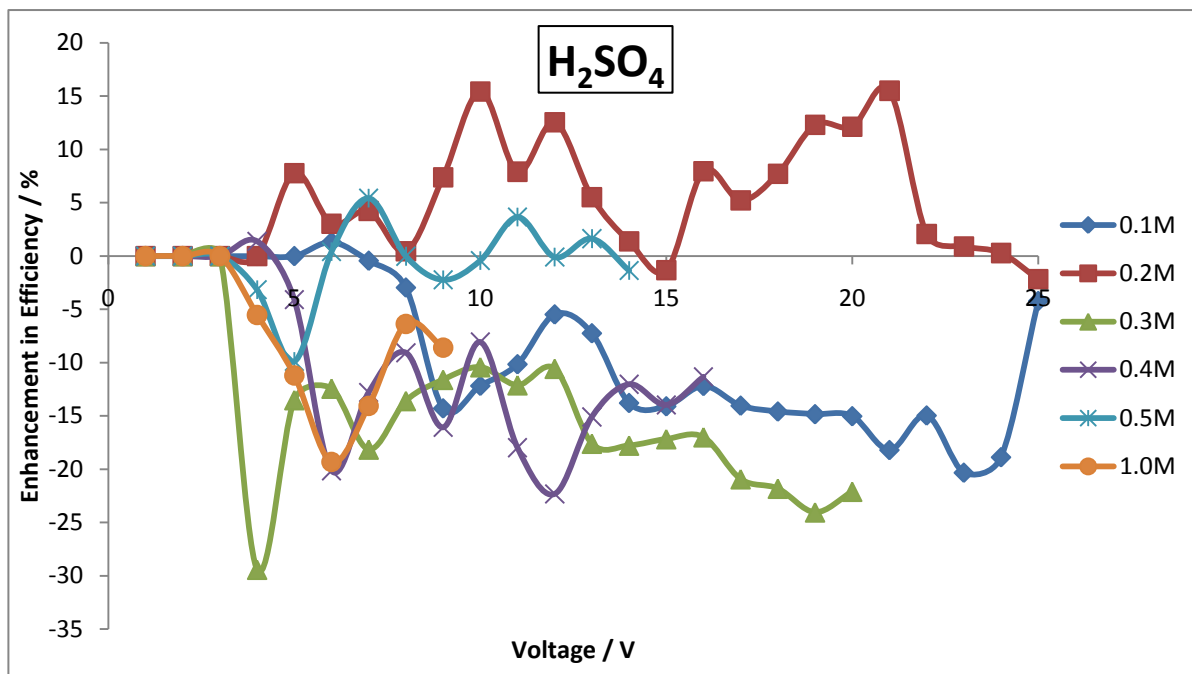

Figure 21: Hydrogen Output Efficiency Enhancement for H<sub>2</sub>SO<sub>4</sub> solution

Figure 21 clearly shows a decreasing efficiency for most of the electrolyte concentration used. This observation is similar to the other electrolytes employed as shown in Figure 19 and Figure 20. 0.2M H<sub>2</sub>SO<sub>4</sub> exhibit an increase in efficiency under sonication to the electrolysis process. Further experimental work is required to generate to produce consistent results with a higher level of reliability.

The use of ultrasound to the electrochemical reactions results in a negative effect on the efficiency of the system when compared to silent conditions. This observation is clearly shown in Figure 19, Figure 20 & Figure 21. As the previous section showed for Hydrogen production rates, the efficiency of Hydrogen production shows similar trends in that, a decrease in Hydrogen production is observed under sonication. Thus sonication has a negative effect on the efficiency of the system.

### 3.2.4 Energy Efficiency Data

Ideally an energy balance on the system should be carried out to calculate how much energy in the form of Hydrogen is produced from the electrical energy used in the system. This process would involve calculating the energy consumption i.e. kWh per m<sup>3</sup> H<sub>2</sub> produced at various cell voltages under silent and sonicated conditions. The silent and sonicated systems can then be directly compared to estimate a saving of energy consumption from sonicated systems compared with silent systems.

In order to demonstrate whether this negative effect of ultrasound was not solely due to enhanced mass-transfer, the investigation turns to the determination of the ultrasonic power used in our conditions. It has been previously shown that the ultrasonic power may affect electrochemical reactions.

### 3.2.5 Ultrasonic Power Determination

Ultrasound produces temperature fluctuations in solutions. These temperature changes ( $dT/dt$ ) can be used to calculate ultrasonic powers using Equation 24.

$$\text{Power (W)} = mC_p\Delta T \quad (24)$$

where  $m$  is the mass of the electrolyte solution (grams),  $C_p$  is the specific heat capacity of electrolyte solution ( $\text{J}\cdot\text{g}^{-1}\cdot\text{K}^{-1}$ ), and  $\Delta T$  is the change in temperature in the electrolyte solution (K).

A concentration of 0.1M was used for each electrolyte and Table 7 shows their corresponding chemical and physical properties.

	Densities ( $\text{g cm}^{-3}$ )	Specific Heat ( $\text{J g}^{-1} \text{K}^{-1}$ )	Mass (g)
Water	1	4.18	1000
NaOH	2.13	3.331	1002.112
NaCl	2.165	3.98	1003.121
H <sub>2</sub> SO <sub>4</sub>	1.84	1.42	1004.5

Table 7: Chemical Properties for each electrolyte solution [94]

For each solution, the temperature rise was measured at 5 second intervals at various ultrasonic amplitudes. The data were then plotted - Temperature vs. Time. The gradient at  $t = 0$  s ( $dT/dt=0$ ) was then used to calculate the ultrasonic power (using Eq. 8). All ultrasonic powers used in this work are shown in Table 8.

Amplitude / %	Ultrasound Power ( $W/cm^2$ )				
	20	25	30	35	40
Water	43.9	65.9	109.9	87.9	131.8
NaOH	10.1	35.1	26.3	29.0	17.5
NaCl	10.5	25.2	10.5	16.8	15.7
H <sub>2</sub> SO <sub>4</sub>	12.4	15.0	11.2	18.7	26.2

**Table 8: Ultrasonic Power Density Table**

It is shown that increasing the amplitude of ultrasound largely increases the power of ultrasound in the solutions as shown by Table 8. A solution containing only water, shows an increase in power through the solution except in one case.

The electrolyte solutions, in most cases, show an increase in ultrasonic power as a result of increasing the ultrasonic amplitude. Please note that all experiments were carried out once and repeats are required to achieve reliability in the findings presented herein.

### **3.3 Erosion of the Electrodes**

In all experiments, it was observed that, over prolonged periods of time the colour of the electrolytes solution turned black as a result of erosion on the carbon electrodes. Acids and alkalines are highly corrosive liquids, which is responsible for the degradation of the carbon electrodes as well the intense effect of ultrasound induced by the implosion of cavitation bubbles on their surfaces.

The use of ultrasound to the solution increases this rate of erosion of the electrodes. NaCl and H<sub>2</sub>SO<sub>4</sub> solutions, showed colour changes from colourless to black at a faster rate due to the mechanical motion caused by the ultrasound. This faster rate of erosion was achieved by the force of ultrasonic waves and cavitation events on the electrodes.

The erosion of the carbon electrodes is a serious issue with regards to the durability and life span of the sonoelectrolytic cell. The use of alternative electrodes or electrolyte solutions must be used if this process is ever to compete on a commercial scale.

### 3.4 Experiments with Industrial Electrolysers

#### 3.4.1 Introduction

As part of my mini-project, an industrial electrolyser was tested on behalf of a company - Miromedia. The principal difference between this unit and the cell researched in previous sections, is that it produces HHO not  $H_2$ . HHO is defined as a mixture of Hydrogen and oxygen gas, where no gas separation has occurred from the electrolysis reaction.

The equipment was set up as illustrated in the Figure 22, and several experiments were carried out to test the effect of varying the cell voltage across the electrolyser. Different concentrations of potassium hydroxide solution were investigated to characterise the conductivity of the solution and the equivalent HHO production. A constant volume of  $300\text{ cm}^3$  of aqueous solution was used for each experiment.

Two plastic tubes were connected from the side arms of the electrolyser, to the underneath of the larger plastic container. The plastic container was placed at a greater height than the electrolyser during operation, so that the KOH dissolved in water solution entered the electrolyser through the force of gravity.

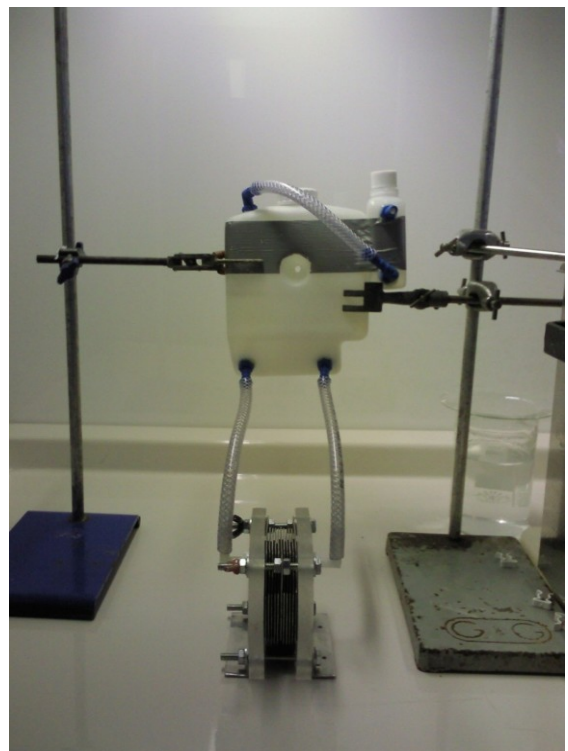

Figure 22: Image of Experimental Setup

During operation, HHO gas was produced and exited the electrolyser through one of the connecting tubes to the KOH solution reservoir. Simultaneously, the KOH solution flowed into the electrolyser through the other tube as a result of gravity. This occurred when the pressure of HHO gas in the electrolyser was great enough to create a force greater than that of gravity forcing the solution into the electrolyser.

The nozzle on the bottom of the side tank, allowing the connection from the main reservoir to the side tank, has been poorly manufactured so suffers from a small leak of distilled water from the side tank reservoir (shown in Figure 23). The joining of the side tank and the main reservoir was achieved using masking tape. The only other connection between the two reservoirs is a plastic tube which allows the flow of HHO gas produced. It is suggested that the two reservoirs should be secured together by stronger means than just using masking tape.



Figure 23: Image showing small leak on side tank

The purpose of the side tank is defined for HHO gas cooling. However, it can be more suitably described as a pressure relief vessel. Safety for the user is paramount and if there was a pressure surge in the system, it would be favourable that the smaller vessel, containing distilled water, ruptured than the larger vessel containing the alkali solution. This is achieved by the connection via tubing of the main reservoir to the side tank.

Various concentrations of KOH solution were used characterise the electrochemical behaviour in terms of the corresponding current flow. As well as measuring the flow of current through the electrolyser, the flow rate of HHO being produced was also measured. It is expected that as the current flowing through the solution increases, the rate of gas production will increase also.

### 3.4.2 Data Analysis

Figure 24 shows the flow of current through the electrolyser at various cell voltages at 298K.

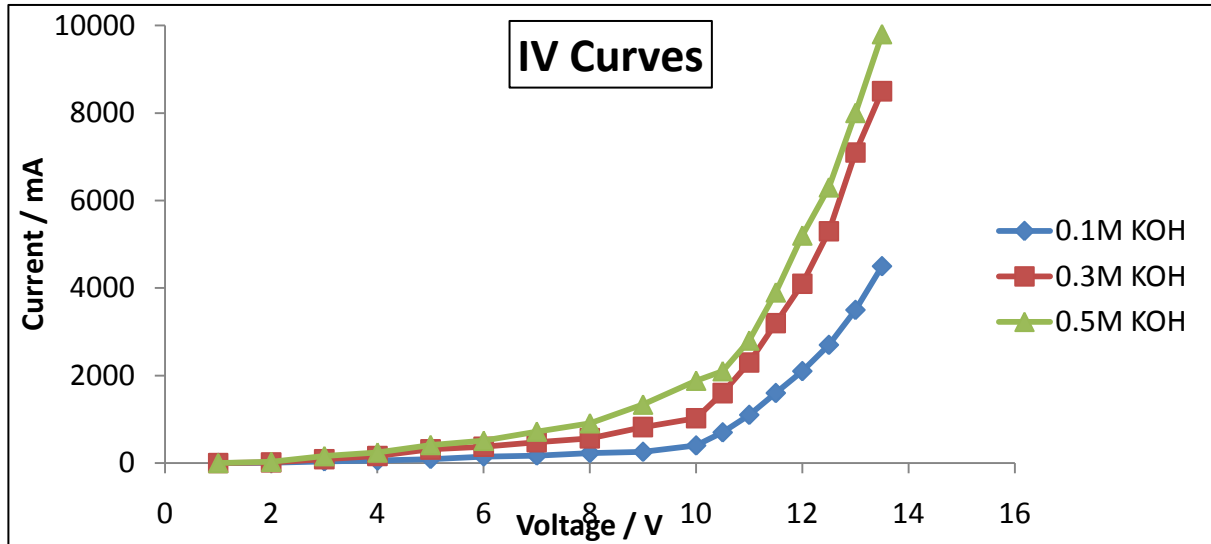

Figure 24: Decomposition Curves for KOH solution

The graph shows, as expected, that with increasing cell voltage, the corresponding flow of current also increases. When extra electrolyte (KOH) is added to the solution e.g. increasing the concentration causes an increase in current flow as a result of further charge carriers in the solution, the conductivity eventually reaches a maximum, where no further addition of electrolyte is necessary.

The results in Figure 24 show a linear increase in current in the range [0-10 V] and thereafter, the rate of current increase occurs at a faster rate. This could be due to possible reasons, but from our general observations, during operation when a cell voltage was applied, the current would steadily decrease over time, and then rapidly increase simultaneously with HHO bubbles discharged from the electrolyser.

During operation, current is flowing and bubbles are forming on the surface of the electrodes. This results in a decrease in surface area on the electrode surface, so the current steadily decreases (i.e.

increase in bubble resistance/overpotential). When the pressure is building up in the electrolyser, this results in a force greater than that from gravity forcing the solution into the electrolyser, the coalesced HHO bubbles release from the electrode surface and leave the electrolyser unit. This release results in a rapid increase in current flow hence the available surface area for current to flow dramatically increases (i.e. decrease in bubble resistance/overpotential).

The decomposition voltages are calculated from Figure 24 and shown in Table 8.

<b>Electrolyte</b>	<b>Concentration (mol.dm<sup>-3</sup>)</b>	<b>Decomposition Voltage (V)</b>
KOH	0.1	2.81
	0.3	1.50
	0.5	2.73

**Table 9: Decomposition Voltages for Industrial Electrolyser**

Table 9 shows that the industrial electrolyser has similar overpotentials as the Sonoelectrochemical cell under investigation herein (Table 4). A concentration of 0.3M KOH solution leads to a decomposition voltage of 1.5V. This figure suggests that an overpotential of approximately 0.3V, and considering stainless steel, the material of the electrode in this electrolyser, has an activation overpotential greater than 0.3V, and taking into account the ohmic overpotential in the solution, further experiments are required to test the reliability of this data.

Figure 25 shows how the flow rate of produced HHO is affected at various cell voltages at 298K.

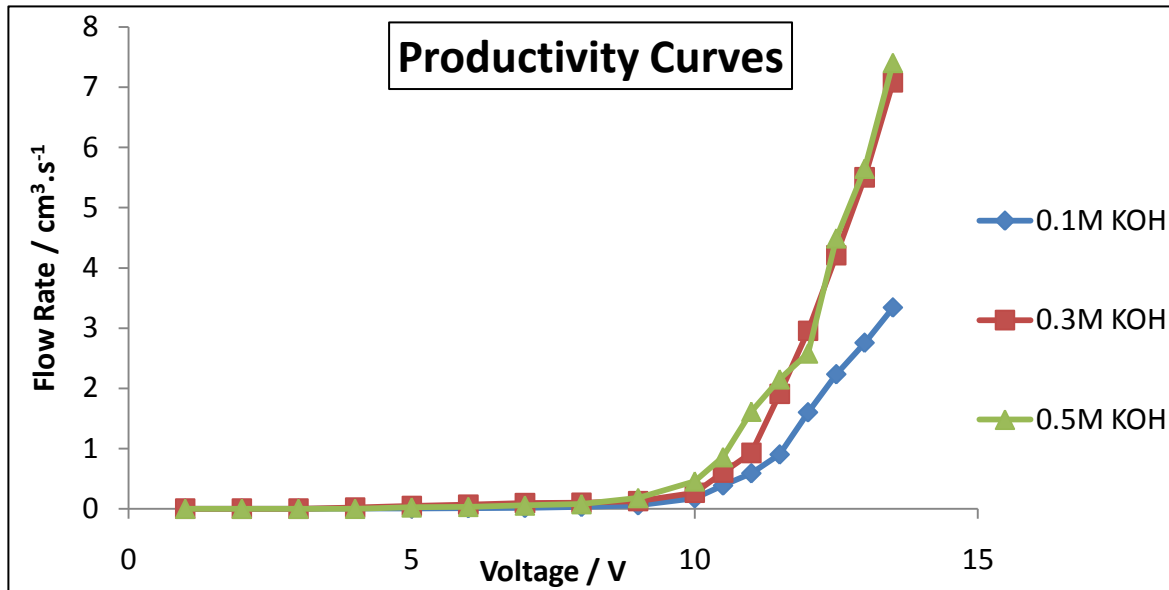

Figure 25: HHO Production for KOH solution

Figure 25 shows similar trends to the conductivity characteristics, in that, HHO production increases with cell voltage. As the concentration of KOH solution increases, the rate of HHO production increases. However, 0.3M and 0.5M solutions of KOH show very similar production rates of HHO. It would be expected that 0.5M KOH has a higher production rate of HHO than 0.3M, but the data obtained from experimentation shows otherwise.

It can be concluded that there is an optimum rate at where HHO can be produced. This is the result of limited space in the electrolyser where the evolution of gas bubbles, the coalescence of these bubbles and then the subsequent release of these bubbles when the upward force is greater than the force of liquid entering the electrolyser occurs. This is the optimum production rate, and any additional electrolyte will not result in any further increase in production rate.



## 4. CONCLUSIONS

Initial experiments in this investigation involved characterising the electrochemical properties of the various electrolyte solutions. The purpose of these experiments was to measure the electrical conductivity of each electrolyte solution and therefore calculate the various decomposition cell voltages.

The results obtained from the electrochemical reactions show that increasing the voltage across the electrolyte solution increases the subsequent flow of current between the electrodes. It is also shown that increasing concentrations of each electrolyte results in an increase in flow of current through the solution. This is to be expected due to the increase in number of charge carriers, with increasing concentration. The data collected and analysed shows that the introduction of ultrasound to the solution increase the flow of current through the solution.

From comparing the different electrolytes at 1.0M concentration, the data shows, as expected considering the ionic make up, that sulphuric acid has a better electrolytic conductivity than sodium hydroxide and sodium chloride respectively. These conclusions were achieved from using basic laboratory equipment and an ultrasonic bath as stated in Chapter 3.

The customised glassware enabled the analysis of ultrasound on the production of hydrogen to occur. The electrochemical data from the customised glassware shows similar trends to that shown with the preliminary experiments.

The productivity data follows a similar trend to that of the electrochemical data with increasing concentration resulting in an increase yield of Hydrogen, but the comparison of silent and sonicated yields show that sonication has, in most cases, a negative effect on Hydrogen production.

Once again, when comparing the efficiency of a silent to a sonicated system, the expected enhancement from the use of ultrasound, only results in a decrease in efficiency for all electrolytes employed.

Previous findings from the literature have shown an increase in Hydrogen production rates from the sonicated solutions, but in this investigation our observations showed otherwise.

A possible explanation for our observations could be due to the large volume of solution used. Here, the electrolyte solution volume was kept constant at  $1,000\text{cm}^3$ , which is a large volume of liquid whereby 'cavitation' in the electrolyte solution may be hindering mass transfer on the electrode surface. Previous studies in this field were performed in smaller volumes of electrolyte solution ( $<100\text{cm}^3$ ) than used in this investigation, and a reduction in reaction volume and modification of reaction vessel geometry are important parameters.

In order to reduce resistances in the electrolytic system, solutions usually undergo a process called 'degassing'. This involves purging the electrolyte solution with non reactive gases, such as nitrogen or argon, to remove any air or gases dissolved in the solution. In this experiment degassing was not performed for all electrolyte solutions used. However, future investigations in this field should include degassing of the electrolyte solutions allowing subsequent comparison of electrochemical behaviour to quantify any improvement (reduction of resistance) in the system.

Commercial electrolyzers usually operate at 1.8V-2.0V. Ideally, they would need to operate at 1.23V but due to overpotentials (due to the electrodes & electrolytes), the electrolyzers would need to operate at higher cell voltages. Since the decomposition cell voltages shown herein are approximately 3V, a clear diminishment in overpotential in the system need to be achieved, in order to be commercially viable.

The carbon electrodes in this research have high activation potentials [0.62V for the Hydrogen evolution reaction (HER) and 0.95V for the oxygen evolution reaction (ORR)] when compared to materials like platinum (0.07V for the HER and 0.77V for the ORR) and palladium (0.07V for the HER and 0.93V for the ORR).

The purpose of this research was to use cost-effective materials, such as carbon, but on the other hand they produce higher overpotentials than precious metals (platinum). The exact opposite is true for platinum and palladium, higher costs and lower overpotentials. Finding a balance between electrode material cost and activation overpotential is an area of active research.

Maximising the productivity of Hydrogen from 'water' electrolysis is an important factor for commercial Hydrogen production systems. The contact area between the electrodes and the electrolyte solution is the critical parameter in determining the number of active sites available for the evolution of Hydrogen gas to occur. It is recommended that research is undertaken in this area, linked in with various reaction vessel geometries to attempt in increasing the contact area between the electrodes and the liquid solution for facile electron transfer.

The 6-month research presented herein was carried out in a closed vessel (batch operation). This could be compared with continuous flow as used by Li *et al.* [87]. The flow through of solution from a supply tank to an electrolysis unit could increase mass transfer on the surface of the electrodes and if only a small volume at a time is subjected to ultrasound in the electrolysis unit, this could demonstrate whether ultrasound has a beneficial effect on the rate of Hydrogen production from electrolysis.

Future investigation in this field may benefit from measurement of flow rate using a flowmeter instead of a measuring cylinder and a stopwatch and a GC. The use a digital flowmeter would be greatly beneficial and would eliminate human error caused by reading values on the measuring cylinder at eye level.

The modification of the sonication distance as shown in Figure 26 is another field worth investigating to see whether this has any effect on the enhancement of electrolysis through the introduction of ultrasound.

The dilemma of carrying out Sonoelectrochemical research on small scale, and commercial Hydrogen production systems require large volume so high contact areas of electrode and

electrolyte can be achieved. One method of potentially overcoming this problem, and requiring research, is the use of localised sonication in the system.

The use of PEM electrolysis would be beneficial when compared to alkaline electrolysis, since there are no acidic/alkaline solutions used in PEM electrolysis. This would result in easier handling for the personnel operating the equipment, whether that is a scientist or a member of the public using the equipment commercially. The electrodes (carbon), which this research has shown, suffer from erosion when subjected to acid/alkaline conditions. Using water instead of these corrosive solutions will increase the lifespan of the electrodes and their durability.

#### **4.1 Comparison for Industrial Electrolyser and Sonoelectrochemical Cell**

From the data presented it is clear that using KOH solution into an electrolyser and applying an electrical current results in HHO production. Increasing the cell voltage and electrolyte concentration, result in an increase in HHO production up to an optimal point. Car batteries operate at 12V and if the electrolyser were connected to them for HHO injection into an internal combustion engine (ICE), an optimum HHO production would occur when using an approximate concentration of 0.3M KOH solution.

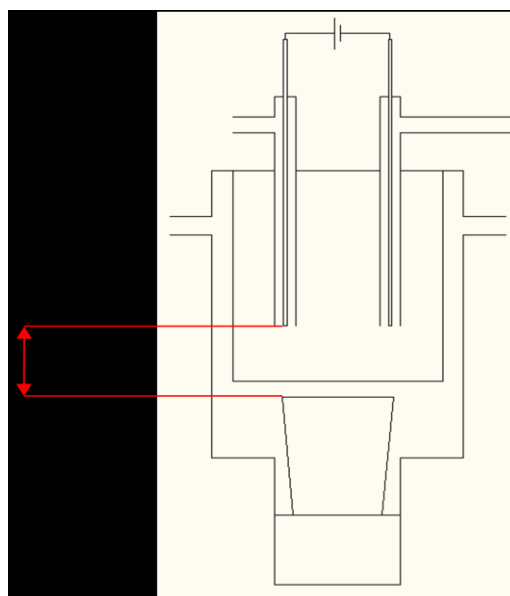

Figure 26: Diagram defining the Sonication Distance

These observations suggest that using 5g of KOH for every 300cm<sup>3</sup> of distilled water added to the main reservoir is recommended. The total volume of the electrolyte solution (to add) is dependent on the rate of usage of the KOH solution and how often the reservoir requires refilling. Any excess KOH will not be dangerous or harmful to the electrolyser; it will not improve the performance further.

A direct comparison between the Miromedia electrolyser unit and the Sonoelectrochemical cell is difficult since the two systems have different gas composition outputs. The Miromedia electrolyser produces a mixture of Hydrogen and oxygen, whilst the Sonoelectrochemical cell produces H<sub>2</sub> only (and in some case Cl<sub>2</sub>).

These are not the only fundamental differences between the experiments observed here and the commercial unit. The Miromedia unit uses stainless steel (SS 316) electrodes and potassium hydroxide electrolyte, whilst the experiments previously performed in this report use carbon electrodes and sodium hydroxide solutions. Stainless steel is a better electrode material than carbon since it has a lower activation overpotential, thus creating less resistance in the flow of electrons through the electrolyte. Potassium hydroxide is a better electrolyte than sodium hydroxide for this purpose, as it is more electrically conductive due to the increased number of charge carriers in solution.

More importantly, the surface area of the electrodes in the Miromedia electrolyser is not known. This makes it impossible to draw any direct comparisons with the Sonoelectrochemical cell. Knowing the contact area allows the conversion of the current to current density, which makes the results independent of contact area. If the contact area, the electrolyte and the electrolyte concentration were kept the same, a conductivity performance comparison of the stainless steel and carbon electrodes could occur.

Hydrogen gas productivity cannot be compared since the two units produce different gases. The Sonoelectrochemical cell separates the Hydrogen and oxygen gas, whilst the Miromedia electrolyser does not. The only way that the gas productivity can be compared is to combine the Hydrogen and oxygen gas resultant flows from the Sonoelectrochemical cell.

## 5. FUTURE WORK

Most importantly for future work, the need to repetition of experiments is a vital requirement. The work shown herein severely lacks reliability from which no defining conclusions can be drawn. A limited time-scale has made repetition not possible at this time, but if it was available multiple repetition of each experiment is a must. This would also enable statistical analysis of the data collected calculate averages and carry out an error analysis.

To improve the process presented above, the use of localised sonication in bulk solutions must be investigated. Using small solutions, which most previous sonoelectrochemical research has used, would not produce Hydrogen on a scale for commercial needs. Since the volume of the electrolyte solution used is very small, there will be a very small contact area between the electrode surface and the electrolyte solution itself. The small contact area results in fewer active sites for Hydrogen production to occur.

### 5.1 Electrolytes

The electrolytes used in this project are fairly weak in comparison to others such as potassium hydroxide because they are more electrically conductive than sodium hydroxide.

Purging of each solution with nitrogen or argon for a fixed period of time before and/or during the electrolysis process would improve the production rate of Hydrogen. This would reduce the volume of air in solution, and reduce ohmic resistance in the solution.

Another possible electrolyte that has been investigated is urea. Urea is the main component of urine and is produced from humans in large quantities every day. The utilisation of a waste product for Hydrogen production could be very economically and environmentally beneficial, rather than using harmful acids/bases, which require costly manufacturing and careful handling.

Another alternative is the use of a solid polymer electrolyte in the form of a membrane. This removes the needs for a liquid electrolyte (acid/base) and can produce Hydrogen via electrolysis through only water. If electrolyser technology is used on a commercial scale in the future, it would be more convenient for the public to have to use only water, rather than handling acids and alkalines which are potential dangers to public health.

## **5.2 Electrode Parameters**

The electrodes have many parameters that can be varied. The use of different material electrodes can be investigated. Each material has different properties, such as conductivity and microstructure. The activation overpotential of each material will be of particular interest, since materials with the lowest activation overpotential will enable the electrolysis reaction to proceed at lower potentials.

The surface area of the electrode in contact with the electrolyte solution is another important factor in electrolysis. Maximising the surface area of electrodes results in more active sites for current flow in the solution and increases the rate of Hydrogen gas production.

The distance between the cathode and anode electrodes affects the productivity of Hydrogen production. When the electrons move through the solution, there is ohmic resistance in the solution and the closer the electrodes are together, the less resistance when transferring from anode to cathode.

## **5.3 Electrolyte Temperature**

The temperature of the electrolyte solution will affect the production of Hydrogen, since increasing the temperature of a solution increases the energy of the ions in solution and they become more energetic, thus reducing the levels of resistance in the solution. An increase in pressure has a similar effect on the solution and applying a pressure to the solution removes the bubbles from the surface



of the electrodes at a faster rate than waiting for bubbles to coalesce and then implode on the surface of the solution.

#### **5.4 Ultrasonic Parameters**

The parameters of the ultrasound applied to the solution can affect the production rate of ultrasound also. Increasing the amplitude of ultrasound will directly increase the flow of current through the solution and this should result in an increase in production of Hydrogen gas.

The frequency of the ultrasound could be adjusted to see what effect this has on the production of Hydrogen; most particularly to the natural resonant frequency of water to see what effect sonication at this frequency has on the productivity. The distance from the electrodes to the source of sonication has been identified in this report as a serious area that requires further research and the closer they are together, the greater the impact that the ultrasound will have on the electrolysis reaction.

## 6. REFERENCES

1. Veziroglu, T.N. and S. Sahin, *21st Century's energy: Hydrogen energy system*. Energy Conversion and Management, 2008. **49**(7): p. 1820-1831.
2. [www.Direct.gov](http://www.Direct.gov). *Brief History of Climate Change*. 2009 [cited 2009 15-11-2009].
3. Lattin, W.C. and V.P. Utgikar, *Transition to hydrogen economy in the United States: A 2006 status report*. International Journal of Hydrogen Energy, 2007. **32**(15): p. 3230-3237.
4. Florides, G.A. and P. Christodoulides, *Global warming and carbon dioxide through sciences*. Environment International, 2009. **35**(2): p. 390-401.
5. <http://www.chemie-im-alltag.de/english/articles/0024/Greenhouse.jpg>. *Diagram of Greenhouse Effect*. 2009 [cited 2009 15-11-2009].
6. Garrett, C.W., *On global climate change, carbon dioxide, and fossil fuel combustion*. Progress in Energy and Combustion Science, 1992. **18**(5): p. 369-407.
7. Jain, P.C., *Greenhouse effect and climate change: scientific basis and overview*. Renewable Energy. **3**(4-5): p. 403-420.
8. Smith, I.M., *CO2 and climatic change: An overview of the science*. Energy Conversion and Management. **34**(9-11): p. 729-735.
9. Susskind, C., *Henry Cavendish, electrician*. Journal of the Franklin Institute, 1950. **249**(3): p. 181-187.
10. Sørensen, B., *Hydrogen and Fuel Cells - Emerging technologies and applications*. Sustainable World. 2005: Elsevier Academic Press. 450.
11. Despic, A.R., *Electrochemistry of John O'Mara Bockris--retrospect and prospects*. Electrochimica Acta, 1994. **39**(11-12): p. 1467-1469.
12. Lau, C.E.G.P.F., *Advances in Hydrogen Energy*. 2000, New York: Springer. 192.
13. Balat, M., *Potential importance of hydrogen as a future solution to environmental and transportation problems*. International Journal of Hydrogen Energy, 2008. **33**(15): p. 4013-4029.
14. Barbir, F., *Transition to renewable energy systems with hydrogen as an energy carrier*. Energy, 2009. **34**(3): p. 308-312.
15. Crowl, D.A. and Y.-D. Jo, *The hazards and risks of hydrogen*. Journal of Loss Prevention in the Process Industries, 2007. **20**(2): p. 158-164.
16. Ltd, H.-F. *Diagram of Flammability Range of Hydrogen and other Fuels*. 2007; Available from: <http://www.hydrogen-fc.com/flammability-range-on-hydrogen-and-other-fuel/>.
17. Winter, C.-J., *Hydrogen energy -- Abundant, efficient, clean: A debate over the energy-system-of-change*. International Journal of Hydrogen Energy, 2009. **34**(14, Supplement 1): p. S1-S52.
18. Ramesohl, S. and F. Merten, *Energy system aspects of hydrogen as an alternative fuel in transport*. Energy Policy, 2006. **34**(11): p. 1251-1259.
19. Elam, C.C., et al., *Realizing the hydrogen future: the International Energy Agency's efforts to advance hydrogen energy technologies*. International Journal of Hydrogen Energy, 2003. **28**(6): p. 601-607.
20. Moriarty, P. and D. Honnery, *Hydrogen's role in an uncertain energy future*. International Journal of Hydrogen Energy, 2009. **34**(1): p. 31-39.
21. Barbir, F., *PEM electrolysis for production of hydrogen from renewable energy sources*. Solar Energy, 2005. **78**(5): p. 661-669.
22. Jensen, S.H., P.H. Larsen, and M. Mogensen, *Hydrogen and synthetic fuel production from renewable energy sources*. International Journal of Hydrogen Energy, 2007. **32**(15): p. 3253-3257.

23. Srinivasan, S. and F.J. Salzano, *Prospects for hydrogen production by water electrolysis to be competitive with conventional methods*. International Journal of Hydrogen Energy, 1977. **2**(1): p. 53-59.
24. Kothari, R., D. Buddhi, and R.L. Sawhney, *Studies on the effect of temperature of the electrolytes on the rate of production of hydrogen*. International Journal of Hydrogen Energy, 2005. **30**(3): p. 261-263.
25. Arashi, H., H. Naito, and H. Miura, *Hydrogen production from high-temperature steam electrolysis using solar energy*. International Journal of Hydrogen Energy, 1991. **16**(9): p. 603-608.
26. Zhang, B., et al., *Hydrogen production from steam reforming of ethanol and glycerol over ceria-supported metal catalysts*. International Journal of Hydrogen Energy, 2007. **32**(13): p. 2367-2373.
27. Levent, M., D. J. Gunn, and M. Ali El-Bousiffi, *Production of hydrogen-rich gases from steam reforming of methane in an automatic catalytic microreactor*. International Journal of Hydrogen Energy, 2003. **28**(9): p. 945-959.
28. Melis, A. and M.R. Melnicki, *Integrated biological hydrogen production*. International Journal of Hydrogen Energy, 2006. **31**(11): p. 1563-1573.
29. Skjånes, K., et al., *H<sub>2</sub> production from marine and freshwater species of green algae during sulfur deprivation and considerations for bioreactor design*. International Journal of Hydrogen Energy, 2008. **33**(2): p. 511-521.
30. Roy, R., Rao, M.L., Kanzius, J., *Observations of polarised RF radiation catalysis of dissociation of H<sub>2</sub>O-NaCl solutions*. Materials Research Innovations, 2008. **12**: p. 3-6.
31. Ahmed, S., et al., *Decomposition of hydrocarbons to hydrogen and carbon*. Applied Catalysis A: General, 2009. **359**(1-2): p. 1-24.
32. Cormos, C.-C., et al., *Innovative concepts for hydrogen production processes based on coal gasification with CO<sub>2</sub> capture*. International Journal of Hydrogen Energy, 2008. **33**(4): p. 1286-1294.
33. Mueller-Langer, F., et al., *Techno-economic assessment of hydrogen production processes for the hydrogen economy for the short and medium term*. International Journal of Hydrogen Energy, 2007. **32**(16): p. 3797-3810.
34. Hallenbeck, P.C., *Fermentative hydrogen production: Principles, progress, and prognosis*. International Journal of Hydrogen Energy, 2009. **34**(17): p. 7379-7389.
35. Kruger, P., *Appropriate technologies for large-scale production of electricity and hydrogen fuel*. International Journal of Hydrogen Energy, 2008. **33**(21): p. 5881-5886.
36. Baykara, S.Z., *Hydrogen production by direct solar thermal decomposition of water, possibilities for improvement of process efficiency*. International Journal of Hydrogen Energy, 2004. **29**(14): p. 1451-1458.
37. Soler, L., et al., *Aluminum and aluminum alloys as sources of hydrogen for fuel cell applications*. Journal of Power Sources, 2007. **169**(1): p. 144-149.
38. Holladay, J.D., et al., *An overview of hydrogen production technologies*. Catalysis Today, 2009. **139**(4): p. 244-260.
39. Getoff, N., *Photoelectrochemical and photocatalytic methods of hydrogen production: A short review*. International Journal of Hydrogen Energy, 1990. **15**(6): p. 407-417.
40. Center, F.S.E. *Diagram of Hydrogen Production Pathways*. Available from: <http://www.fsec.ucf.edu/en/consumer/hydrogen/basics/production.htm>.
41. Andújar, J.M. and F. Segura, *Fuel cells: History and updating. A walk along two centuries*. Renewable and Sustainable Energy Reviews, 2009. **13**(9): p. 2309-2322.
42. T.J. Mason, J.P.L.a.D.J.W., *Sonoelectrochemistry*. Ultrasonics, 1990. **28**: p. 333-337.
43. Courtney, J., *Diagram of MEA*. 2010. p. Poster Presentation, Japan.

44. Levie, R.d., *What's in a Name?* Journal of Chemical Education, 2000. **7**(5): p. 610-612.
45. Toftlund, H., *Very early observations on fuel cells*. Ionics, 2001. **7**(3): p. 161-164.
46. Laboratory, M.L.-N.H.M.F. *Magnet Lab - National High Magnetic Field Laboratory - 1850-1869*. 2010 [cited 2010 29/09/2010]; Available from: <http://www.magnet.fsu.edu/education/tutorials/timeline/1850-1869.html>.
47. History, S. *Dimitry Lachinov*. [cited 2010 29/09/2010]; Available from: [http://www.servinghistory.com/topics/Dimitry\\_Lachinov](http://www.servinghistory.com/topics/Dimitry_Lachinov).
48. Laskin, J.B. and R.D. Feldwick, *Recent development of large electrolytic hydrogen generators*. International Journal of Hydrogen Energy, 1978. **3**(3): p. 311-320.
49. Kreuter, W. and H. Hofmann, *Electrolysis: The important energy transformer in a world of sustainable energy*. International Journal of Hydrogen Energy, 1998. **23**(8): p. 661-666.
50. Justi, E.W., *Seventy years of Fuel Cell Research*. British Journal of Applied Sciences, 1963. **14**(12): p. 840.
51. Zuttel, A., Borgschulte, A., Schlapbach, L., *Hydrogen as a Future Energy Carrier*. 2008, Weinheim: Wiley.
52. Richards, J.W., *Electrolysis of Water*. The Electrical Section, 1905: p. 377-394.
53. Stojic, D.L., et al., *Hydrogen generation from water electrolysis--possibilities of energy saving*. Journal of Power Sources, 2003. **118**(1-2): p. 315-319.
54. Grigoriev, S.A., V.I. Poremsky, and V.N. Fateev, *Pure hydrogen production by PEM electrolysis for hydrogen energy*. International Journal of Hydrogen Energy, 2006. **31**(2): p. 171-175.
55. Madigan, N.A., et al., *Effects of sonication on electrode surfaces and metal particles*. Ultrasonics Sonochemistry, 1996. **3**(3): p. S239-S247.
56. Mason, T.J., *Sonochemistry and sonoprocessing: the link, the trends and (probably) the future*. Ultrasonics Sonochemistry, 2003. **10**(4-5): p. 175-179.
57. Mason, T.J., *Sonochemistry and the environment - Providing a "green" link between chemistry, physics and engineering*. Ultrasonics Sonochemistry, 2007. **14**(4): p. 476-483.
58. Walton, D.J., L.D. Burke, and M.M. Murphy, *Sonoelectrochemistry: Chlorine, hydrogen and oxygen evolution at platinised platinum*. Electrochimica Acta, 1996. **41**(17): p. 2747-2751.
59. Walton, D.J., et al., *Ultrasonic enhancement of electrochemiluminescence*. Electrochimica Acta, 1993. **38**(2-3): p. 307-310.
60. González-García, J., et al., *Current topics on sonoelectrochemistry*. Ultrasonics, 2009. **In Press, Corrected Proof**.
61. Moriguchi, N.J., *The effect of supersonic waves on chemical phenomena*. Journal of the Chemical Society Japan, 1934(55): p. 749.
62. Nyborg, W.L.S., M. I. L. , *Effects of acoustic microstreaming at electrodes*. Proceedings of the 3rd International Congress on Acoustics, 1960, 1960: p. 346-348.
63. Zhang, H.H.C., L. A. , *Effects of High-Intensity Ultrasound on Glassy-Carbon. Electrodes*. Analytical Chemistry, 1993(65): p. 1552.
64. Compton, R.G., et al., *Dual activation: coupling ultrasound to electrochemistry--an overview*. Electrochimica Acta, 1997. **42**(19): p. 2919-2927.
65. Klíma, J., C. Bernard, and C. Degrand, *Sonoelectrochemistry: Effects of ultrasound on voltammetric measurements at a solid electrode*. Journal of Electroanalytical Chemistry, 1994. **367**(1-2): p. 297-300.
66. Hagan, C.R.S.C., L. A., *Comparison of Hydrodynamic Voltammetry Implemented by Sonication to a Rotating-Disk Electrode*. Analytical Chemistry, 1994. **66**: p. 399.
67. Marken, F., J.C. Eklund, and R.G. Compton, *Voltammetry in the presence of ultrasound: Can ultrasound modify heterogeneous electron transfer kinetics?* Journal of Electroanalytical Chemistry, 1995. **395**(1-2): p. 335-339.

68. Compton, R.G.E., J. C.; Page, S. D., *Sonovoltammetry - Heterogeneous Electron -Transfer processes with coupled ultrasonically induced chemical-reaction*. Journal Of Physical Chemistry, 1995(99): p. 4211-4214.
69. Pollet, B. *Schematic of Ultrasonic Phenomena*. 2007 [cited 2010 04/10/2010]; Available from: <http://www.sonoelectrochemistry.com/>.
70. Birkin, P.R.S.-M., S. , *The effect of ultrasound on mass transport to a microelectrode*. Journal of Electroanalytical Chemistry, 1996(416): p. 1807.
71. Birkin, P.R. and S. Silva-Martinez, *A study on the effect of ultrasound on electrochemical phenomena*. Ultrasonics Sonochemistry, 1997. **4**(2): p. 121-122.
72. Birkin, P.R.O., D. G.; Leighton, T. G. , *A novel dual microelectrode for investigating mass transfer and surface erosion caused by cavitation*. Electrochemistry Communications, 2004(6): p. 1174.
73. Birkin, P.R.O., D. G.; Leighton, T. G., *Experimental and theoretical characterisation of sonochemical cells - Part 2 Cell disruptors (Ultrasonic horns) and cavity cluster collapse*. Physical Chemistry Chemical Physics, 2005(7): p. 530.
74. Maisonhaute, E.W., P. C.; Compton, R. G. , *Surface acoustic cavitation understood via nanosecond electrochemistry*. Journal Of Physical Chemistry, 2001(105): p. 12087-12091.
75. Birkin, P.R.P., J. F.; Leighton, T. G.; Vincüotte, A. M. L., *Cathodic Electrochemical Detection of Sonochemical Radical Products*. Analytical Chemistry, 2002(74): p. 2584.
76. Gaitan, D.F.C., L. A.; Church, C. C.; Roy, R. A. , *Sonoluminescence and bubble dynamics for a single, stable, cavitation bubble*. Journal of the Acoustical Society of America, 1992. **91**(6): p. 3166.
77. Weissler, A.C., H. W.; Snyder, S., *Chemical Effect of Ultrasonic Waves: Oxidation of Potassium Iodide Solution by Carbon Tetrachloride*. Journal of the American Chemical Society, 1950. **4**(72): p. 1769-1775.
78. Weissler, A., *Formation of Hydrogen Peroxide by Ultrasonic Waves: Free Radicals*. Journal of the American Chemical Society, 1959. **5**(81): p. 1077-1081.
79. Birkin, P.R.P., J. F.; Leighton, T. G., *Electrochemical evidence of H radicals produced by ultrasound*. Journal of the Chemical Society Chemical Communications, 2001.
80. Birkin, P.R.O.C., R.; Rappale, C.; Silva-Martinez, S. , *Electrochemical measurement of erosion from individual cavitation generated from continuous ultrasound*. Journal of Chemical Society, 1998(94): p. 3365.
81. Galloway, W.J., *An Experimental Study of Acoustically Induced Cavitation in Liquids*. Journal of the Acoustical Society of America, 1954(26): p. 849.
82. Cataldo, F., *Effects of ultrasound on the yield of hydrogen and chlorine during electrolysis of aqueous solutions of NaCl or HCl*. Journal of Electroanalytical Chemistry, 1992. **332**: p. 325-331.
83. D. J. Walton, L.D.B., M. M. Murphy, *Sonoelectrochemistry: Chlorine, Hydrogen and Oxygen Evolution at Platinised Platinum*. Electrochimica Acta, 1996. **41**: p. 2747-2751.
84. H.N. McMurray, D.A.W., B.P. Wilson, *Hydrogen Evolution and Oxygen Reduction at Titanium Sonotrode*. Chemical Communications, 1998: p. 887-888.
85. C. Burdischak, C.H., R.L. Opila, *Electroanalytical Effects of ultrasound on hydrogen evolution reaction in KOH*. 2008, University of Delaware.
86. Sasikala, R., O.D. Jayakumar, and S.K. Kulshreshtha, *Enhanced hydrogen generation by particles during sonochemical decomposition of water*. Ultrasonics Sonochemistry, 2007. **14**(2): p. 153-156.
87. Li, S.-D., C.-C. Wang, and C.-Y. Chen, *Water electrolysis in the presence of an ultrasonic field*. Electrochimica Acta, 2009. **54**(15): p. 3877-3883.

88. Thomas, R., et al., *Trap-governed hydrogen diffusivity and uptake capacity in ultrahigh-strength AERMET 100 steel*. Metallurgical and Materials Transactions A, 2002. **33**(7): p. 1991-2004.
89. Melsheimer, J. and D. Ziegler, *The oxygen electrode reaction in acid solutions on RuO<sub>2</sub> electrodes prepared by the thermal decomposition method*. Thin Solid Films, 1988. **163**: p. 301-308.
90. Shi, K., et al., *Structural studies of electrochemically activated glassy carbon electrode: Effects of chloride anion on the redox responses of copper deposition*. Electrochimica Acta, 2007. **52**(19): p. 5907-5913.



NaCl

0.1M		0.2M		0.3M		0.4M		0.5M		1.0M		
V	mA	V	mA	V	mA	V	mA	V	mA	V	mA	
1	1	0.5	2	0.5	0	0.5	1	0.5	1	0.25	0	
2	4	1	3	1	2	1	5	1	3	0.5	0	
3	8	1.5	6	1.5	5	1.5	11	1.5	12	0.75	0	
4	23	2	7	2	7	2	23	2	31	1	0	
5	44	2.5	11	2.5	9	2.5	40	2.5	44	1.25	0	
6	66	3	14	3	14	3	57	3	55	1.5	0	
7	89	3.5	25	3.5	31	3.5	74	3.5	74	1.75	0	
8	112	4	42	4	53	4	92	4	100	2	0	
9	136	4.5	62	4.5	77	4.5	111	4.5	129	2.25	2	
10	160	5	83	5	102	5	130	5	141	2.5	5	
11	184	5.5	104	5.5	127	5.5	149	5.5	195	2.75	10	
12	208	6	125	6	154	6	181	6	229	3	20	
13	234	6.5	147	6.5	181	6.5	214	6.5	262	3.25	36	
14	259	7	169	7	209	7	247	7	297	3.5	57	
15	285	7.5	192	7.5	236	7.5	281	7.5	329	3.75	81	
16	310	8	214	8	264	8	316	8	363	4	109	
17	336	8.5	237	8.5	293	8.5	351	8.5	399	4.25	138	
18	362	9	260	9	320	9	386	9	435	4.5	168	
19	389	9.5	283	9.5	349	9.5	421	9.5	471	4.75	199	
20	414	10	305	10	378	10	456	10	510	5	230	
21	439	10.5	328	10.5	407	10.5	492	10.5	552	5.25	263	
22	465	11	350	11	435	11	527	11	600	5.5	295	
23	491	11.5	374	11.5	464	11.5	564	11.5	645	5.75	328	
24	519	12	397	12	495	12	600	12	693	6	361	
25	547	12.5	420	12.5	514	12.5	636	12.5	739	6.25	394	
		13	444	13	544	13	673	13	775	6.5	428	
		13.5	468	13.5	573	13.5	709	13.5	821	6.75	461	
		14	492	14	602	14	746	14	867	7	494	
		14.5	515	14.5	635	14.5	784	14.5	913	7.25	529	
		15	539	15	662	15	812	15	952	7.5	563	
		15.5	564	15.5	692	15.5	850	15.5	1000	7.75	594	
		16	589	16	723	16	888	16	1044	8	625	
		16.5	615	16.5	754	16.5	924	16.5	1092	8.25	661	
		17	638	17	787	17	961	17	1136	8.5	694	
		17.5	665	17.5	815	17.5	999	17.5	1180	8.75	728	
		18	690	18	847	18	1035	18	1223	9	761	
		18.5	714	18.5	878	18.5	1074	18.5	1276	9.25	794	
		19	740	19	908	19	1109	19	1328	9.5	827	
		19.5	767	19.5	935	19.5	1146	19.5	1375	9.75	859	
		20	789	20	966	20	1184	20	1423	10	894	
		20.5	814	20.5	995	20.5	1220	20.5	1469	10.25	928	
		21	843	21	1024	21	1259	21	1516	10.5	963	
		21.5	867	21.5	1056	21.5	1293	21.5	1559	10.75	997	
		22	892	22	1084	22	1324	22	1602	11	1030	
		22.5	915	22.5	1118	22.5	1361	22.5	1648	11.25	1064	
		23	941	23	1145	23	1398	23	1694	11.5	1097	
		23.5	968	23.5	1172	23.5	1434	23.5	1742	11.75	1125	
		24	995	24	1204	24	1472	24	1790	12	1159	
		24.5	1021	24.5	1237	24.5	1510	24.5	1833	12.25	1194	
		25	1046	25	1268	25	1548	25	1881	12.5	1227	
										12.75	1262	
										13	1295	
										13.25	1329	
										13.5	1364	
										13.75	1396	
										14	1435	
										14.25	1465	
										14.5	1500	
										14.75	1534	
										15	1569	
										15.25	1606	
										15.5	1637	
										15.75	1665	
										16	1699	
										16.25	1734	
										16.5	1774	
										16.75	1803	
										17	1844	
										17.25	1876	
										17.5	1908	
										17.75	1940	
										18	1978	
Electrode Contact Length				3.5 cm								
Electrode Diameter				0.15 cm								
Contact Area				1.667008 cm <sup>2</sup>								

Figure 28: Table of Voltage Current Data for NaCl





0.1M		0.2M		0.3M		0.4M		0.5M		1.0M	
V	mA	V	mA	V	mA	V	mA	V	mA	V	mA
1	1	0.5	3	0.5	1	0.5	0	0.5	0	0.25	0
2	7	1	9	1	3	1	1	1	0	0.5	0
3	12	1.5	15	1.5	14	1.5	2	1.5	0	0.75	0
4	44	2	28	2	37	2	10	2	7	1	0
5	76	2.5	35	2.5	51	2.5	41	2.5	44	1.25	0
6	137	3	61	3	97	3	102	3	133	1.5	0
7	198	3.5	108	3.5	172	3.5	175	3.5	262	1.75	0
8	265	4	160	4	259	4	261	4	419	2	6
9	332	4.5	215	4.5	351	4.5	356	4.5	587	2.25	22
10	437	5	273	5	448	5	431	5	762	2.5	43
11	504	5.5	331	5.5	541	5.5	541	5.5	941	2.75	80
12	591	6	392	6	637	6	661	6	1125	3	134
13	686	6.5	452	6.5	734	6.5	776	6.5	1311	3.25	206
14	777	7	512	7	830	7	915	7	1504	3.5	287
15	860	7.5	573	7.5	932	7.5	1051	7.5	1690	3.75	381
16	955	8	636	8	1031	8	1169	8	1910	4	482
17	1049	8.5	699	8.5	1131	8.5	1299			4.25	585
18	1133	9	762	9	1229	9	1441			4.5	692
19	1228	9.5	827	9.5	1333	9.5	1579			4.75	807
20	1312	10	890	10	1438	10	1712			5	922
21	1401	10.5	956	10.5	1542	10.5	1846			5.25	1041
22	1496	11	1019	11	1647	11	1985			5.5	1157
23	1589	11.5	1088	11.5	1749					5.75	1278
24	1673	12	1154	12	1854					6	1395
25	1766	12.5	1228	12.5	1958					6.25	1515
		13	1296							6.5	1647
		13.5	1367							6.75	1764
		14	1439							7	1891
		14.5	1512							7.25	2000
		15	1582								
		15.5	1653								
		16	1725								
		16.5	1800								
		17	1876								
		17.5	1955								
								Electrode Contact Length		3.5 cm	
								Electrode Diameter		0.15 cm	
								Contact Area		1.667008 cm <sup>2</sup>	

Figure 29: Table of Voltage Current Data for H<sub>2</sub>SO<sub>4</sub>

**Sonicated**

**NaOH**

0.1M		0.2M		0.3M		0.4M		0.5M		1.0M	
V	mA	V	mA	V	mA	V	mA	V	mA	V	mA
1	10	0.5	7	0.5	0	0.5	10	0.5	7	0.25	0
2	46	1	13	1	0	1	21	1	18	0.5	3
3	80	1.5	23	1.5	16	1.5	29	1.5	27	0.75	8
4	115	2	35	2	35	2	40	2	35	1	15
5	140	2.5	51	2.5	61	2.5	77	2.5	87	1.25	19
6	203	3	65	3	87	3	116	3	147	1.5	17
7	258	3.5	99	3.5	129	3.5	186	3.5	231	1.75	20
8	323	4	134	4	192	4	272	4	322	2	22
9	403	4.5	183	4.5	257	4.5	359	4.5	419	2.25	56
10	464	5	224	5	318	5	445	5	515	2.5	119
11	531	5.5	256	5.5	382	5.5	536	5.5	608	2.75	172
12	632	6	290	6	453	6	628	6	702	3	222
13	707	6.5	304	6.5	527	6.5	727	6.5	805	3.25	299
14	774	7	341	7	593	7	820	7	902	3.5	379
15	843	7.5	383	7.5	661	7.5	917	7.5	1014	3.75	447
16	916	8	440	8	734	8	1012	8	1121	4	504
17	990	8.5	490	8.5	804	8.5	1109	8.5	1246	4.25	580
18	1059	9	528	9	878	9	1202	9	1365	4.5	657
19	1142	9.5	567	9.5	951	9.5	1301	9.5	1483	4.75	733
20	1221	10	620	10	1027	10	1403	10	1607	5	810
21	1297	10.5	682	10.5	1096	10.5	1504	10.5	1729	5.25	898
22	1381	11	740	11	1175	11	1602	11	1846	5.5	985
23	1463	11.5	782	11.5	1254	11.5	1707			5.75	1070
24	1546	12	821	12	1324	12	1812			6	1155
25	1625	12.5	865	12.5	1401	12.5	1922			6.25	1246
		13	915	13	1476					6.5	1334
		13.5	968	13.5	1569					6.75	1430
		14	1015	14	1667					7	1520
		14.5	1063	14.5	1710					7.25	1613
		15	1114	15	1755					7.5	1701
		15.5	1168	15.5	1843					7.75	1794
		16	1228	16	1936					8	1882
		16.5	1269							8.25	1975
		17	1313							8.5	2061
		17.5	1369								
		18	1426								
		18.5	1477								
		19	1522								
		19.5	1583								
		20	1642								
		20.5	1701								
		21	1763								
		21.5	1810								
		22	1898								

Electrode Contact Length	3.5 cm
Electrode Diameter	0.15 cm
Contact Area	1.667008 cm <sup>2</sup>

**Figure 30: Table of Voltage Current Data for NaOH Sonicated**

NaCl

0.1M		0.2M		0.3M		0.4M		0.5M		1.0M		
V	mA	V	mA	V	mA	V	mA	V	mA	V	mA	
1	5	0.5	10	0.5	0	0.5	0	0.5	0	0.25	0	
2	14	1	17	1	0	1	0	1	0	0.5	0	
3	24	1.5	25	1.5	0	1.5	0	1.5	0	0.75	0	
4	43	2	36	2	0	2	0	2	0	1	0	
5	70	2.5	49	2.5	10	2.5	0	2.5	0	1.25	0	
6	99	3	63	3	24	3	23	3	24	1.5	0	
7	127	3.5	80	3.5	49	3.5	58	3.5	64	1.75	0	
8	157	4	98	4	80	4	103	4	120	2	0	
9	187	4.5	117	4.5	119	4.5	155	4.5	184	2.25	0	
10	216	5	132	5	162	5	210	5	251	2.5	8	
11	248	5.5	148	5.5	206	5.5	268	5.5	318	2.75	18	
12	283	6	167	6	256	6	327	6	389	3	38	
13	317	6.5	184	6.5	304	6.5	384	6.5	460	3.25	67	
14	350	7	202	7	353	7	444	7	532	3.5	107	
15	382	7.5	221	7.5	400	7.5	506	7.5	605	3.75	156	
16	419	8	239	8	451	8	567	8	678	4	209	
17	458	8.5	257	8.5	500	8.5	629	8.5	746	4.25	265	
18	495	9	278	9	551	9	690	9	820	4.5	321	
19	530	9.5	299	9.5	601	9.5	749	9.5	894	4.75	382	
20	568	10	327	10	655	10	812	10	963	5	441	
21	605	10.5	352	10.5	715	10.5	872	10.5	1036	5.25	502	
22	644	11	377	11	766	11	936	11	1110	5.5	565	
23	676	11.5	403	11.5	823	11.5	999	11.5	1178	5.75	626	
24	719	12	427	12	878	12	1065	12	1250	6	676	
25	752	12.5	452	12.5	926	12.5	1125	12.5	1318	6.25	739	
		13	478	13	980	13	1190	13	1385	6.5	798	
		13.5	501	13.5	1035	13.5	1251	13.5	1456	6.75	857	
		14	531	14	1086	14	1315	14	1525	7	921	
		14.5	559	14.5	1145	14.5	1376	14.5	1593	7.25	980	
		15	585	15	1196	15	1435	15	1654	7.5	1035	
		15.5	612	15.5	1246	15.5	1503	15.5	1720	7.75	1095	
		16	643	16	1301	16	1567	16	1780	8	1157	
		16.5	669	16.5	1351	16.5	1616	16.5	1842	8.25	1216	
		17	698	17	1401	17	1678	17	1900	8.5	1277	
		17.5	724	17.5	1457	17.5	1742	17.5	1949	8.75	1333	
		18	757	18	1514	18	1799	18	1967	9	1399	
		18.5	787	18.5	1569	18.5	1861	18.5	2016	9.25	1455	
		19	817	19	1609	19	1901	19	2060	9.5	1514	
		19.5	840	19.5	1665	19.5	1967			9.75	1572	
		20	872	20	1716	20	2018			10	1630	
		20.5	903	20.5	1760	20.5	2082			10.25	1688	
		21	947	21	1800	21	2134			10.5	1744	
		21.5	983	21.5	1856	21.5	2182			10.75	1792	
		22	1009	22	1895					11	1851	
		22.5	1040	22.5	1929					11.25	1902	
		23	1070	23	1959					11.5	1952	
		23.5	1111	23.5	1986							
		24	1146	24	2010							
		24.5	1176	24.5	2028							
		25	1206	25	2046							
										Electrode Contact Length		3.5 cm
										Electrode Diameter		0.15 cm
										Contact Area		1.667008 cm <sup>2</sup>

Figure 31: Table of Voltage Current Data for NaCl Sonicated

H2SO4

0.1M		0.2M		0.3M		0.4M		0.5M		1.0M	
V	mA	V	mA	V	mA	V	mA	V	mA	V	mA
1	5	0.5	9	0.5	5	0.5	0	0.5	0	0.25	0
2	15	1	14	1	14	1	1	1	0	0.5	0
3	42	1.5	19	1.5	23	1.5	6	1.5	0	0.75	0
4	105	2	34	2	58	2	13	2	25	1	0
5	175	2.5	47	2.5	81	2.5	47	2.5	47	1.25	0
6	248	3	68	3	101	3	116	3	140	1.5	0
7	358	3.5	124	3.5	202	3.5	242	3.5	287	1.75	0
8	484	4	186	4	321	4	398	4	468	2	9
9	584	4.5	251	4.5	457	4.5	573	4.5	668	2.25	23
10	664	5	325	5	599	5	747	5	875	2.5	50
11	745	5.5	400	5.5	742	5.5	927	5.5	1087	2.75	99
12	829	6	481	6	895	6	1112	6	1300	3	176
13	909	6.5	554	6.5	1047	6.5	1302	6.5	1517	3.25	272
14	996	7	634	7	1204	7	1486	7	1733	3.5	386
15	1078	7.5	713	7.5	1364	7.5	1678	7.5	1952	3.75	516
16	1167	8	795	8	1521	8	1868			4	652
17	1255	8.5	878	8.5	1686	8.5	2053			4.25	798
18	1347	9	961	9	1859					4.5	954
19	1430	9.5	1047	9.5	2022					4.75	1110
20	1525	10	1132							5	1269
21	1617	10.5	1216							5.25	1422
22	1707	11	1304							5.5	1574
23	1799	11.5	1386							5.75	1736
24	1878	12	1475							6	1893
25	1966	12.5	1553							6.25	2057
		13	1638								
		13.5	1714								
		14	1795								
		14.5	1871								
		15	1955								
								Electrode Contact Length		3.5 cm	
								Electrode Diameter		0.15 cm	
								Contact Area		1.667008 cm <sup>2</sup>	

Figure 32: Table of Voltage Current Data for H2SO4 Sonicated

## 7.1.2 Custom Glassware Experiments

### *Silent*

NaOH

NaOH	0.1M						
Unsonicated	Contact Area (cm <sup>2</sup> )	6.668			Production Rate		
Voltage (V)	Applied Current (mA)	Current Density (mA/cm <sup>2</sup> )	Vol (cm <sup>3</sup> )	Temp (oC)	Time (s)	cm <sup>3</sup> /hour	g/hour
1	0	0	0	25		#DIV/0!	#DIV/0!
2	0	0	0	25		#DIV/0!	#DIV/0!
3	0	0	0	25		#DIV/0!	#DIV/0!
4	23	3.449310138	0	25		#DIV/0!	#DIV/0!
5	48	7.198560288	1	25	1041	3.458213256	0.00031
6	68	10.19796041	1	25	377.928	9.525623928	0.00086
7	86	12.89742052	1	25	187.818	19.16749193	0.00172
8	105	15.74685063	1	25	141.108	25.5123735	0.00229
9	124	18.59628074	1	25	121.92	29.52755906	0.00265
10	144	21.59568086	1	25	79.704	45.16711834	0.00406
11	164	24.59508098	1	25	62.742	57.37783303	0.00516
12	185	27.74445111	1	25	59	61.01694915	0.00548
13	203	30.44391122	1	25	46	78.26086957	0.00703
14	227	34.04319136	1	25	43	83.72093023	0.00752
15	248	37.19256149	1	25	42	85.71428571	0.0077
16	268	40.19196161	1	25	40	90	0.00809
17	290	43.49130174	1	25	38	94.73684211	0.00851
18	311	46.64067187	1	25	30	120	0.01079
19	331	49.64007199	1	25	29	124.137931	0.01116
20	352	52.78944211	2	25	39	184.6153846	0.01659
21	373	55.93881224	2	25	45	160	0.01438
22	392	58.78824235	2	25	44	163.6363636	0.01471
23	412	61.78764247	2	25	38	189.4736842	0.01703
24	432	64.78704259	3	25	59	183.0508475	0.01645
25	455	68.23635273	6	25	89.4	241.6107383	0.02172

Figure 33: Data for 0.1M NaOH Silent

NaOH	0.2M						
Unsonicated	Contact Area (cm <sup>2</sup> )	6.668030407				Production Rate	
Voltage (V)	Applied Current (mA)	Current Density (mA/cm <sup>2</sup> )	Vol (cm <sup>3</sup> )	Temp (oC)	Time (s)	cm <sup>3</sup> /hour	g/hour
1	0	0	0	25		#DIV/0!	#DIV/0!
2	1	0.149969322	0	25		#DIV/0!	#DIV/0!
3	22	3.299325086	0	25		#DIV/0!	#DIV/0!
4	56	8.398282038	0	25		#DIV/0!	#DIV/0!
5	94	14.09711628	1	25	189	19.04761905	0.001712
6	133	19.94591984	1	25	135	26.66666667	0.0023968
7	171	25.64475408	1	25	71	50.70422535	0.004557296
8	205	30.74371103	1	25	44	81.81818182	0.007353818
9	246	36.89245324	1	25	36	100	0.008988
10	277	41.54150223	1	25	31	116.1290323	0.010437677
11	314	47.09036714	1	25	30	120	0.0107856
12	354	53.08914003	2	25	56	128.5714286	0.011556
13	392	58.78797427	2	25	54	133.3333333	0.011984
14	433	64.93671647	2	25	42	171.4285714	0.015408
15	473	70.93548936	2	25	41	175.6097561	0.015783805
16	513	76.93426224	2	25	38	189.4736842	0.017029895
17	552	82.78306581	2	25	37	194.5945946	0.017490162
18	594	89.08177733	2	25	35	205.7142857	0.0184896
19	637	95.53045819	2	25	28	257.1428571	0.023112
20	678	101.6792004	2	25	27	266.6666667	0.023968
21	716	107.3780346	2	25	25	288	0.02588544
22	762	114.2766234	2	25	23	313.0434783	0.028136348
23	802	120.2753963	2	25	22	327.2727273	0.029415273
24	849	127.3239545	4	25	41	351.2195122	0.03156761
25	880	131.9730035	5	25	46	391.3043478	0.035170435

Figure 34: Data for 0.2M NaOH Silent

NaOH	0.3M						
Unsonicated	Contact Area (cm2)	7.610508203				Production Rate	
Voltage (V)	Applied Current (mA)	Current Density (mA/cm2)	Vol (cm3)	Temp (oC)	Time (s)	cm3/hour	g/hour
1	0	0	0	25		#DIV/0!	#DIV/0!
2	2	0.26279454	0	25		#DIV/0!	#DIV/0!
3	32	4.204712635	0	25		#DIV/0!	#DIV/0!
4	84	11.03737067	1	25	210	17.14285714	0.0015408
5	140	18.39561778	1	25	140	25.71428571	0.0023112
6	198	26.01665943	1	25	68	52.94117647	0.004758353
7	255	33.50630381	1	25	48	75	0.006741
8	317	41.65293454	2	25	54	133.3333333	0.011984
9	370	48.61698984	2	25	49	146.9387755	0.013206857
10	423	55.58104514	2	25	46	156.5217391	0.014068174
11	479	62.93929225	2	25	36	200	0.017976
12	540	70.95452571	2	25	34	211.7647059	0.019033412
13	585	76.86740286	2	25	28	257.1428571	0.023112
14	655	86.06521174	2	25	27	266.6666667	0.023968
15	718	94.34323974	2	25	25	288	0.02588544
16	778	102.2270759	2	25	24	300	0.026964
17	836	109.8481176	2	25	21	342.8571429	0.030816
18	902	118.5203374	2	25	19	378.9473684	0.034059789
19	956	125.61579	2	25	18	400	0.035952
20	1027	134.9449961	2	25	16	450	0.040446
21	1082	142.171846	2	25	15	480	0.0431424
22	1144	150.3184767	2	25	14	514.2857143	0.046224
23	1205	158.3337102	3	25	20	540	0.0485352
24	1255	164.9035736	3	25	19	568.4210526	0.051089684
25	1337	175.6781498	5	25	30	600	0.053928

Figure 35: Data for 0.3M NaOH Silent

NaOH	0.4M						
Unsonicated	Contact Area (cm2)	6.668030407				Production Rate	
Voltage (V)	Applied Current (mA)	Current Density (mA/cm2)	Vol (cm3)	Temp (oC)	Time (s)	cm3/hour	g/hour
1	0	0	0	25		#DIV/0!	#DIV/0!
2	0	0	0	25		#DIV/0!	#DIV/0!
3	38	5.69883424	0	25		#DIV/0!	#DIV/0!
4	97	14.54702424	1	25	192	18.75	0.00168525
5	161	24.14506086	1	25	80	45	0.0040446
6	226	33.8930668	1	25	42	85.71428571	0.007704
7	294	44.0909807	1	25	39	92.30769231	0.008296615
8	360	53.98895596	1	25	36	100	0.008988
9	426	63.88693122	1	25	20	180	0.0161784
10	489	73.33499851	1	25	17	211.7647059	0.019033412
11	558	83.68288174	2	25	33	218.1818182	0.019610182
12	622	93.28091835	2	25	30	240	0.0215712
13	686	102.878955	2	25	31	232.2580645	0.020875355
14	758	113.6767462	2	25	24	300	0.026964
15	826	123.8746601	2	25	21	342.8571429	0.030816
16	892	133.7726353	2	25	20	360	0.0323568
17	963	144.4204572	2	25	19	378.9473684	0.034059789
18	1028	154.1684631	2	25	17	423.5294118	0.038066824
19	1096	164.366377	2	25	17	423.5294118	0.038066824
20	1170	175.4641069	2	25	16	450	0.040446
21	1238	185.6620208	3	25	20	540	0.0485352
22	1320	197.9595052	3	25	19	568.4210526	0.051089684
23	1390	208.4573577	4	25	23	626.0869565	0.056272696
24	1456	218.355333	5	25	27	666.6666667	0.05992
25	1550	232.4524493	5	25	26	692.3076923	0.062224615

Figure 36: Data for 0.4M NaOH Silent



NaOH	0.5M						
Unsonicated	Contact Area (cm2)	6.668030407				Production Rate	
Voltage (V)	Applied Current (mA)	Current Density (mA/cm2)	Vol (cm3)	Temp (oC)	Time (s)	cm3/hour	g/hour
1	0	0	0	25		#DIV/0!	#DIV/0!
2	0	0	0	25		#DIV/0!	#DIV/0!
3	113	16.9465334	1	25	75	48	0.00431424
4	196	29.39398713	1	25	66	54.54545455	0.004902545
5	283	42.44131816	1	25	45	80	0.0071904
6	375	56.23849579	1	25	28	128.5714286	0.011556
7	465	69.73573478	2	25	42	171.4285714	0.015408
8	561	84.13278971	3	25	46	234.7826087	0.021102261
9	656	98.37987531	3	25	43	251.1627907	0.022574512
10	746	111.8771143	3	25	39	276.9230769	0.024889846
11	830	124.4745374	5	25	52	346.1538462	0.031112308
12	923	138.4216843	5	25	46	391.3043478	0.035170435
13	1021	153.1186779	5	25	57	315.7894737	0.028383158
14	1106	165.8660703	5	25	49	367.3469388	0.033017143
15	1205	180.7130331	4	25	40	360	0.0323568
16	1258	188.6614072	4	25	35	411.4285714	0.0369792
17	1410	211.4567442	5	25	28	642.8571429	0.05778
18	1510	226.4536764	5	25	30	600	0.053928
19	1592	238.7511608	5	25	28	642.8571429	0.05778
20	1662	249.2490134	10	25	56	642.8571429	0.05778
21	1758	263.6460683	10	25	45	800	0.071904
22	1853	277.8931539	10	25	43	837.2093023	0.075248372
23	1950	292.4401781	10	25	42	857.1428571	0.07704
24	2028	304.1377852	10	25	39	923.0769231	0.082966154
25		0				#DIV/0!	#DIV/0!

Figure 37: Data for 0.5M NaOH Silent

NaOH	1.0M						
Unsonicated	Contact Area (cm2)	6.668030407				Production Rate	
Voltage (V)	Applied Current (mA)	Current Density (mA/cm2)	Vol (cm3)	Temp (oC)	Time (s)	cm3/hour	g/hour
1	0	0	0	25		#DIV/0!	#DIV/0!
2	0	0	0	25		#DIV/0!	#DIV/0!
3	65	9.748005937	0	25		#DIV/0!	#DIV/0!
4	173	25.94469273	1	25	92	39.13043478	0.003517043
5	254	38.09220782	1	25	53	67.9245283	0.006105057
6	371	55.6386185	2	25	56	128.5714286	0.011556
7	500	74.98466106	2	25	38	189.4736842	0.017029895
8	622	93.28091835	3	25	44	245.4545455	0.022061455
9	748	112.1770529	3	25	38	284.2105263	0.025544842
10	880	131.9730035	3	25	29	372.4137931	0.033472552
11	1009	151.319046	3	25	27	400	0.035952
12	1143	171.4149352	5	25	40	450	0.040446
13	1262	189.2612845	5	25	33	545.4545455	0.049025455
14	1420	212.9564374	5	25	25	720	0.0647136
15	1550	232.4524493	5	25	26	692.3076923	0.062224615
16	1693	253.8980623	10	25	48	750	0.06741
17	1845	276.6933993	10	25	43	837.2093023	0.075248372
18	2000	299.9386442	10	25	41	878.0487805	0.078919024
19		0				#DIV/0!	#DIV/0!
20		0				#DIV/0!	#DIV/0!
21		0				#DIV/0!	#DIV/0!
22		0				#DIV/0!	#DIV/0!
23		0				#DIV/0!	#DIV/0!
24		0				#DIV/0!	#DIV/0!
25		0				#DIV/0!	#DIV/0!

Figure 38: Data for 1.0M NaOH Silent

NaOH												
Unsonicated	0.1M		0.2M		0.3M		0.4M		0.5M		1.0M	
Voltage (V)	V ideal	Efficiency (%)	V ideal	Efficiency (%)	V ideal	Efficiency (%)	V ideal	Efficiency (%)	V ideal	Efficiency (%)	V ideal	Efficiency (%)
1	0	#DIV/0!	0	#DIV/0!	0	#DIV/0!	0	#DIV/0!	0	#DIV/0!	0	#DIV/0!
2	0	#DIV/0!	0	#DIV/0!	0	#DIV/0!	0	#DIV/0!	0	#DIV/0!	0	#DIV/0!
3	0	#DIV/0!	0	#DIV/0!	0	#DIV/0!	0	#DIV/0!	1.63266	61.24975627	0	#DIV/0!
4	0	#DIV/0!	0	#DIV/0!	2.977408	33.58625475	3.587805	27.87219096	2.492045	40.12768123	3.066125	32.6145
5	9.626045167	10.38848232	3.422517	29.21826435	3.308232	30.22762927	2.481257	40.30214941	2.453324	40.76102744	2.593376	38.5598
6	4.950783218	20.19882422	3.458927	28.91070367	2.272553	44.00338189	1.828579	54.68728239	2.022764	49.43730328	4.002376	49.9703
7	3.111656088	32.13722763	2.338893	42.75526599	2.065957	48.40372008	2.208858	45.27225575	3.762341	53.15839062	3.66024	54.6412
8	2.854281901	35.03508184	1.737651	57.54896723	2.889302	69.22088256	2.496669	40.05337071	4.971376	60.34546436	5.272286	56.9013
9	2.912410361	34.33582071	1.706057	58.61468884	3.060114	65.35703627	1.641329	60.92625404	5.434107	55.2068581	5.475719	54.7873
10	2.211049867	45.22738337	1.654236	60.45087742	3.284264	60.8964471	1.601451	62.44336394	5.60479	53.52564285	4.91628	61.0217
11	1.982248668	50.44775744	1.814708	55.10527435	2.910569	68.71509323	3.54735	56.38011126	8.314523	60.1357373	5.248206	57.1624
12	2.102711395	47.55764401	3.818979	52.37002466	3.098935	64.53829344	3.594741	55.63683648	8.179287	61.13002077	8.807693	56.7686
13	1.798911499	55.5891716	4.077892	49.04494373	2.764736	72.33962562	4.096771	48.81893016	11.21131	44.59780439	8.02286	62.3219
14	1.880399994	53.18017461	3.503427	57.08695528	2.985004	67.00158708	3.504583	57.06812713	10.44016	47.89198845	6.838869	73.1115
15	2.006581942	49.83599121	3.735949	53.533923	3.029733	66.01242716	3.341606	59.85145675	9.28545	43.07814808	7.763561	64.4034
16	2.065145777	48.42273175	3.755406	53.25655939	3.151597	63.45989008	3.436772	58.19413502	8.482124	47.15799995	15.65504	63.8772
17	2.122939036	47.10450857	3.934565	50.8315398	2.96323	67.49390907	3.524811	56.74063337	7.605593	65.74109478	15.28343	65.4304
18	1.797370345	55.63683648	4.005073	49.93666998	2.892677	69.14010197	3.36665	59.40623534	8.726782	57.2948879	15.79682	63.3039
19	1.849191634	54.07768355	3.436002	58.20718596	2.904492	68.85884865	3.589347	55.72044702	8.587308	58.22546711	0	#DIV/0!
20	2.644619518	75.6252454	3.526545	56.71273729	2.773513	72.11070275	3.606299	55.45851329	17.92978	55.77313095	0	#DIV/0!
21	3.233532824	61.85185397	3.448331	57.99907088	2.739418	73.00819886	4.76987	62.89479213	15.24008	65.61644348	0	#DIV/0!
22	3.322727086	60.19152185	3.376282	59.23675504	2.703298	73.98370802	4.831516	62.09230675	15.3497	65.14786636	0	#DIV/0!
23	3.016037527	66.31217225	3.399014	58.84058993	4.067775	73.7503984	6.158835	64.94734869	15.77756	63.38115805	0	#DIV/0!
24	4.910115258	61.0983621	6.705752	59.65028405	4.024734	74.53909001	7.573229	66.02203963	15.23661	65.63137668	0	#DIV/0!
25	7.836187946	76.56784194	7.798237	64.11705588	6.77006	73.8545916	7.763561	64.40343479	0	#DIV/0!	0	#DIV/0!

Figure 39: Data of NaOH Efficiency of H<sub>2</sub> production

NaCl	0.1M							
Unsonicated	Contact Area (cm2)	6.668030407				Production Rate		
Voltage (V)	Applied Current (mA)	Current Density (mA/cm2)	Vol (cm3)	Temp (oC)	Time (s)	cm3/hour	g/hour	
1	0	0	0	15		#DIV/0!	#DIV/0!	
2	0	0	0	15		#DIV/0!	#DIV/0!	
3	1	0.149969322	0	15		#DIV/0!	#DIV/0!	
4	3	0.449907966	0	15		#DIV/0!	#DIV/0!	
5	9	1.349723899	0	15		#DIV/0!	#DIV/0!	
6	17	2.549478476	0	15		#DIV/0!	#DIV/0!	
7	26	3.899202375	0	15		#DIV/0!	#DIV/0!	
8	35	5.248926274	0	15		#DIV/0!	#DIV/0!	
9	45	6.748619495	0	15		#DIV/0!	#DIV/0!	
10	55	8.248312716	0	15		#DIV/0!	#DIV/0!	
11	65	9.748005937	1	15	228	15.78947	0.001419	
12	73	10.94776051	1	15	199	18.09045	0.001626	
13	88	13.19730035	1	15	176	20.45455	0.001838	
14	95	14.2470856	1	15	134	26.86567	0.002415	
15	104	15.5968095	1	15	120	30	0.002696	
16	114	17.09650272	1	15	108	33.33333	0.002996	
17	132	19.79595052	1	15	92	39.13043	0.003517	
18	140	20.9957051	1	15	90	40	0.003595	
19	144	21.59558238	1	15	78	46.15385	0.004148	
20	156	23.39521425	1	15	69	52.17391	0.004689	
21	175	26.24463137	1	15	71	50.70423	0.004557	
22	181	27.1444473	1	15	60	60	0.005393	
23	190	28.4941712	1	15	55	65.45455	0.005883	
24	200	29.99386442	1	15	53	67.92453	0.006105	
25	218	32.69331222	1	15	50	72	0.006471	

Figure 40: Data for 0.1M NaCl Silent

NaCl	0.2M							
Unsonicated	Contact Area (cm <sup>2</sup> )	6.668030407					Production Rate	
Voltage (V)	Applied Current (mA)	Current Density (mA/cm <sup>2</sup> )	Vol (cm <sup>3</sup> )	Temp (oC)	Time (s)	cm <sup>3</sup> /hour	g/hour	
1	0	0	0	15		#DIV/0!	#DIV/0!	
2	1	0.149969322	0	15		#DIV/0!	#DIV/0!	
3	4	0.599877288	0	15		#DIV/0!	#DIV/0!	
4	16	2.399509154	0	15		#DIV/0!	#DIV/0!	
5	30	4.499079663	0	15		#DIV/0!	#DIV/0!	
6	45	6.748619495	0	15		#DIV/0!	#DIV/0!	
7	62	9.298097971	0	15		#DIV/0!	#DIV/0!	
8	78	11.69760712	0	15		#DIV/0!	#DIV/0!	
9	94	14.09711628	1	15	180	20	0.001798	
10	109	16.34665611	1	15	147	24.4898	0.002201	
11	127	19.04610391	1	15	92	39.13043	0.003517	
12	150	22.49539832	1	15	90	40	0.003595	
13	170	25.49478476	1	15	72	50	0.004494	
14	189	28.34420188	1	15	63	57.14286	0.005136	
15	209	31.34358832	1	15	54	66.66667	0.005992	
16	238	35.69269866	1	15	47	76.59574	0.006884	
17	246	36.89245324	1	15	44	81.81818	0.007354	
18	278	41.69147155	1	15	43	83.72093	0.007525	
19	287	43.04119545	1	15	33	109.0909	0.009805	
20	315	47.24033647	1	15	29	124.1379	0.011158	
21	329	49.33990698	2	15	62	116.129	0.010438	
22	340	50.98956952	2	15	52	138.4615	0.012445	
23	380	56.9883424	2	15	48	150	0.013482	
24	386	57.88815834	2	15	46	156.5217	0.014068	
25	397	59.53782088	2	15	44	163.6364	0.014708	

Figure 41: Data for 0.2M NaCl Silent

NaCl	0.3M							
Unsonicated	Contact Area (cm2)	6.668030407					Production Rate	
Voltage (V)	Applied Current (mA)	Current Density (mA/cm2)	Vol (cm3)	Temp (oC)	Time (s)	cm3/hour	g/hour	
1	0	0				#DIV/0!	#DIV/0!	
2	1	0.149969322				#DIV/0!	#DIV/0!	
3	4	0.599877288				#DIV/0!	#DIV/0!	
4	22	3.299325086				#DIV/0!	#DIV/0!	
5	45	6.748619495				#DIV/0!	#DIV/0!	
6	68	10.1979139				#DIV/0!	#DIV/0!	
7	92	13.79717763				#DIV/0!	#DIV/0!	
8	120	17.99631865	1	15	122	29.5082	0.002652	
9	145	21.74555171	1	15	75	48	0.004314	
10	173	25.94469273	1	15	62	58.06452	0.005219	
11	206	30.89368036	1	15	48	75	0.006741	
12	228	34.19300544	1	15	39	92.30769	0.008297	
13	255	38.24217714	1	15	38	94.73684	0.008515	
14	280	41.99141019	1	15	37	97.2973	0.008745	
15	317	47.54027511	1	15	38	94.73684	0.008515	
16	339	50.8396002	1	15	37	97.2973	0.008745	
17	360	53.98895596	2	15	50	144	0.012943	
18	403	60.43763681	2	15	46	156.5217	0.014068	
19	432	64.78674715	2	15	45	160	0.014381	
20	454	68.08607224	2	15	43	167.4419	0.01505	
21	480	71.98527461	2	15	39	184.6154	0.016593	
22	504	75.58453834	2	15	37	194.5946	0.01749	
23	540	80.98343394	2	15	34	211.7647	0.019033	
24	572	85.78245225	2	15	33	218.1818	0.01961	
25	599	89.83162395	2	15	32	225	0.020223	

Figure 42: Data for 0.3M NaCl Silent

NaCl	0.4M							
Unsonicated	Contact Area (cm <sup>2</sup> )	5.72552611					Production Rate	
Voltage (V)	Applied Current (mA)	Current Density (mA/cm <sup>2</sup> )	Vol (cm <sup>3</sup> )	Temp (oC)	Time (s)	cm <sup>3</sup> /hour	g/hour	
1	2	0.349311261				#DIV/0!	#DIV/0!	
2	5	0.873278151				#DIV/0!	#DIV/0!	
3	17	2.969145715				#DIV/0!	#DIV/0!	
4	37	6.46225832				#DIV/0!	#DIV/0!	
5	64	11.17796034				#DIV/0!	#DIV/0!	
6	93	16.24297362				#DIV/0!	#DIV/0!	
7	125	21.83195378	1	15	135	26.66667	0.002397	
8	153	26.72231143	1	15	98	36.73469	0.003302	
9	192	33.53388101	1	15	79	45.56962	0.004096	
10	221	38.59889429	1	15	56	64.28571	0.005778	
11	259	45.23580824	1	15	44	81.81818	0.007354	
12	292	50.99944404	1	15	43	83.72093	0.007525	
13	329	57.46170236	1	15	39	92.30769	0.008297	
14	347	60.60550371	2	15	55	130.9091	0.011766	
15	383	66.8931064	2	15	52	138.4615	0.012445	
16	433	75.62588791	2	15	50	144	0.012943	
17	462	80.69090119	2	15	47	153.1915	0.013769	
18	488	85.23194758	2	15	41	175.6098	0.015784	
19	534	93.26610657	2	15	39	184.6154	0.016593	
20	569	99.37905363	2	15	34	211.7647	0.019033	
21	609	106.3652788	2	15	31	232.2581	0.020875	
22	634	110.7316696	2	15	30	240	0.021571	
23	648	113.1768484	2	15	30	240	0.021571	
24	676	118.0672061	2	15	25	288	0.025885	
25	717	125.2280869	2	15	24	300	0.026964	

Figure 43: Data for 0.4M NaCl Silent

NaCl	0.5M							
Unsonicated	Contact Area (cm <sup>2</sup> )	6.668030407					Production Rate	
Voltage (V)	Applied Current (mA)	Current Density (mA/cm <sup>2</sup> )	Vol (cm <sup>3</sup> )	Temp (oC)	Time (s)	cm <sup>3</sup> /hour	g/hour	
1	0	0				#DIV/0!	#DIV/0!	
2	1	0.149969322				#DIV/0!	#DIV/0!	
3	9	1.349723899				#DIV/0!	#DIV/0!	
4	40	5.998772885				#DIV/0!	#DIV/0!	
5	76	11.39766848				#DIV/0!	#DIV/0!	
6	111	16.64659475				#DIV/0!	#DIV/0!	
7	146	21.89552103				#DIV/0!	#DIV/0!	
8	196	29.39398713	1	15	55	65.45455	0.005883	
9	238	35.69269866	1	15	46	78.26087	0.007034	
10	286	42.89122612	1	15	39	92.30769	0.008297	
11	319	47.84021375	2	15	71	101.4085	0.009115	
12	357	53.53904799	2	15	50	144	0.012943	
13	424	63.58699258	2	15	48	150	0.013482	
14	458	68.68594953	2	15	43	167.4419	0.01505	
15	504	75.58453834	2	15	37	194.5946	0.01749	
16	558	83.68288174	2	15	37	194.5946	0.01749	
17	597	89.5316853	2	15	33	218.1818	0.01961	
18	650	97.48005937	3	15	42	257.1429	0.023112	
19	692	103.7787709	3	15	38	284.2105	0.025545	
20	740	110.9772984	3	15	38	284.2105	0.025545	
21	777	116.5261633	3	15	35	308.5714	0.027734	
22	826	123.8746601	3	15	33	327.2727	0.029415	
23	864	129.5734943	3	15	32	337.5	0.030335	
24	913	136.9219911	3	15	26	415.3846	0.037335	
25	945	141.7210094	4	15	40	360	0.032357	

Figure 44: Data for 0.5M NaCl Silent



NaCl	1.0M							
Unsonicated	Contact Area (cm2)	7.610508203					Production Rate	
Voltage (V)	Applied Current (mA)	Current Density (mA/cm2)	Vol (cm3)	Temp (oC)	Time (s)	cm3/hour	g/hour	
1	0	0		15		#DIV/0!	#DIV/0!	
2	1	0.13139727		15		#DIV/0!	#DIV/0!	
3	10	1.313972698		15		#DIV/0!	#DIV/0!	
4	60	7.88383619		15		#DIV/0!	#DIV/0!	
5	122	16.03046692	1	15	124	29.03226	0.002609	
6	204	26.80504305	1	15	63	57.14286	0.005136	
7	283	37.18542736	1	15	48	75	0.006741	
8	336	44.14948267	2	15	59	122.0339	0.010968	
9	438	57.55200419	2	15	44	163.6364	0.014708	
10	494	64.9102513	2	15	39	184.6154	0.016593	
11	576	75.68482743	3	15	50	216	0.019414	
12	645	84.75123905	3	15	40	270	0.024268	
13	710	93.29206159	3	15	37	291.8919	0.026235	
14	780	102.4898705	3	15	34	317.6471	0.02855	
15	860	113.0016521	3	15	28	385.7143	0.034668	
16	928	121.9366664	3	15	27	400	0.035952	
17	1003	131.7914616	3	15	26	415.3846	0.037335	
18	1077	141.5148596	3	15	23	469.5652	0.042205	
19	1154	151.6324494	3	15	21	514.2857	0.046224	
20	1228	161.3558474	4	15	31	464.5161	0.041751	
21	1305	171.4734371	4	15	29	496.5517	0.04463	
22	1353	177.7805061	4	15	27	533.3333	0.047936	
23	1414	185.7957396	4	15	28	514.2857	0.046224	
24	1498	196.8331102	4	15	27	533.3333	0.047936	
25	1558	204.7169464	5	15	30	600	0.053928	

Figure 45: Data for 1.0M NaCl Silent

NaCl												
Unsonicated	0.1M		0.2M		0.3M		0.4M		0.5M		1.0M	
Voltage (V)	V ideal	Efficiency (%)	V ideal	Efficiency (%)	V ideal	Efficiency (%)	V ideal	Efficiency (%)	V ideal	Efficiency (%)	V ideal	Efficiency (%)
1	0	#DIV/0!	0	#DIV/0!	0	#DIV/0!	0	#DIV/0!	0	#DIV/0!	0	#DIV/0!
2	0	#DIV/0!	0	#DIV/0!	0	#DIV/0!	0	#DIV/0!	0	#DIV/0!	0	#DIV/0!
3	0	#DIV/0!	0	#DIV/0!	0	#DIV/0!	0	#DIV/0!	0	#DIV/0!	0	#DIV/0!
4	0	#DIV/0!	0	#DIV/0!	0	#DIV/0!	0	#DIV/0!	0	#DIV/0!	0	#DIV/0!
5	0	#DIV/0!	0	#DIV/0!	0	#DIV/0!	0	#DIV/0!	0	#DIV/0!	2.46773	40.52236952
6	0	#DIV/0!	0	#DIV/0!	0	#DIV/0!	0	#DIV/0!	0	#DIV/0!	2.096498	47.69859991
7	0	#DIV/0!	0	#DIV/0!	0	#DIV/0!	3.659011	27.32979148	0	#DIV/0!	2.215906	45.128269
8	0	#DIV/0!	0	#DIV/0!	2.725717	36.68759007	3.251153	30.75831874	2.007051	49.82433382	3.233813	61.84648971
9	0	#DIV/0!	3.150214	31.74387226	2.024739	49.38908677	3.288881	30.4054741	2.03833	49.05976604	3.143768	63.61793338
10	0	#DIV/0!	2.983208	33.52095853	1.996998	50.07517421	2.683491	37.26488616	2.076684	48.15369541	3.142789	63.63774588
11	2.75923	36.24199181	2.175361	45.96938708	1.840976	54.31900471	2.470998	40.46948325	4.216856	47.42870048	4.698034	63.85650063
12	2.704679	36.97296886	2.513469	39.78565323	1.655538	60.40331968	2.722521	36.73066511	3.323364	60.17997968	4.208655	71.28167512
13	2.8836	34.67886871	2.278878	43.88123518	1.804112	55.42892865	2.782149	35.9434363	3.789194	52.78167439	4.285325	70.00636536
14	2.370108	42.19216957	2.21688	45.10845037	1.928855	51.84423925	4.138206	48.3301264	3.666686	54.54517301	4.326106	69.34642602
15	2.323562	43.03736527	2.10126	47.59049429	2.242759	44.58793945	4.318392	46.31353998	3.471938	57.60471027	3.928078	76.37322334
16	2.292284	43.62461977	2.082642	48.01594123	2.335292	42.82120056	4.694375	42.6041784	3.843932	52.03006089	4.087289	73.39827658
17	2.261005	44.22812241	2.015243	49.62179588	3.351292	59.67847984	4.708252	42.47860654	3.667989	54.52579246	4.254004	70.52178918
18	2.345904	42.6274856	2.22563	44.93109575	3.451458	57.94652267	4.33834	46.10058288	5.082793	59.02267237	4.040798	74.24275234
19	2.091206	47.81929475	1.763338	56.71062386	3.619395	55.25785171	4.515707	44.28985222	4.895865	61.27620002	3.9532	75.88789379
20	2.004072	49.89839452	1.700781	58.79653187	3.634662	55.02574722	4.194798	47.67809688	5.235463	57.30152759	6.209887	64.41340822
21	2.313322	43.22787272	3.797758	52.66264522	3.485343	57.3831537	4.093539	48.85748516	5.063243	59.25055914	6.17351	64.7929614
22	2.021946	49.45730374	3.291713	60.75863333	3.471938	57.60471027	4.124112	48.49529245	5.074973	59.1136164	5.959162	67.12352862
23	1.945611	51.39773384	3.395976	58.89323669	3.418318	58.50831357	4.21518	47.44755465	5.147584	58.27976547	6.458492	61.93396707
24	1.973539	50.67040742	3.305863	60.49857159	3.514388	56.90891276	3.664431	54.57872558	4.419609	67.87930558	6.597801	60.62625783
25	2.029393	49.27580905	3.252243	61.49602915	3.568753	56.04197815	3.731215	53.60183998	7.037713	56.83664747	7.624517	65.57792106

Figure 46: Data of NaCl Efficiency of H<sub>2</sub> production

H2SO4	0.1M							
Unsonicated	Contact Area (cm2)	6.668030407					Production Rate	
Voltage (V)	Applied Current (mA)	Current Density (mA/cm2)	Vol (cm3)	Temp (oC)	Time (s)	cm3/hour	g/hour	
1	0	0	0	28		#DIV/0!	#DIV/0!	
2	1	0.149969322	0	28		#DIV/0!	#DIV/0!	
3	16	2.399509154	0	28		#DIV/0!	#DIV/0!	
4	45	6.748619495	0	28		#DIV/0!	#DIV/0!	
5	78	11.69760712	0	28		#DIV/0!	#DIV/0!	
6	109	16.34665611	1	28	189	19.04762	0.001712	
7	146	21.89552103	1	28	117	30.76923	0.002766	
8	178	26.69453934	1	28	86	41.86047	0.003762	
9	213	31.94346561	1	28	56	64.28571	0.005778	
10	247	37.04242256	1	28	47	76.59574	0.006884	
11	283	42.44131816	1	28	42	85.71429	0.007704	
12	318	47.69024443	1	28	37	97.2973	0.008745	
13	352	52.78920138	1	28	31	116.129	0.010438	
14	390	58.48803562	2	28	48	150	0.013482	
15	425	63.7369619	2	28	46	156.5217	0.014068	
16	459	68.83591885	2	28	44	163.6364	0.014708	
17	508	76.18441563	2	28	38	189.4737	0.01703	
18	536	80.38355665	2	28	35	205.7143	0.01849	
19	569	85.33254428	2	28	32	225	0.020223	
20	610	91.48128649	2	28	29	248.2759	0.022315	
21	649	97.33009005	2	28	26	276.9231	0.02489	
22	677	101.5292311	3	28	40	270	0.024268	
23	720	107.9779119	3	28	35	308.5714	0.027734	
24	760	113.9766848	3	28	33	327.2727	0.029415	
25	795	119.2256111	4	28	52	276.9231	0.02489	

Figure 47: Data for 0.1M H<sub>2</sub>SO<sub>4</sub> Silent

H2SO4	0.2M							
Unsonicated	Contact Area (cm2)	5.725552611					Production Rate	
Voltage (V)	Applied Current (mA)	Current Density (mA/cm2)	Vol (cm3)	Temp (oC)	Time (s)	cm3/hour	g/hour	
1	0	0	0	28		#DIV/0!	#DIV/0!	
2	1	0.17465563	0	28		#DIV/0!	#DIV/0!	
3	25	4.366390757	0	28		#DIV/0!	#DIV/0!	
4	77	13.44848353	0	28		#DIV/0!	#DIV/0!	
5	141	24.62644387	1	28	105	34.28571	0.003082	
6	206	35.97905984	1	28	51	70.58824	0.006344	
7	275	48.03029833	1	28	48	75	0.006741	
8	342	59.73222556	2	28	69	104.3478	0.009379	
9	410	71.60880841	2	28	51	141.1765	0.012689	
10	479	83.6600469	2	28	40	180	0.016178	
11	544	95.01266287	3	28	48	225	0.020223	
12	618	107.9371795	3	28	45	240	0.021571	
13	686	119.8137624	3	28	41	263.4146	0.023676	
14	756	132.0396565	3	28	36	300	0.026964	
15	822	143.5669281	3	28	35	308.5714	0.027734	
16	896	156.4914447	3	28	33	327.2727	0.029415	
17	971	169.590617	3	28	28	385.7143	0.034668	
18	1049	183.2137562	4	28	35	411.4286	0.036979	
19	1106	193.1691271	4	28	34	423.5294	0.038067	
20	1189	207.6655444	4	28	32	450	0.040446	
21	1249	218.1448822	4	28	31	464.5161	0.041751	
22	1329	232.1173326	4	28	25	576	0.051771	
23	1401	244.692538	4	28	24	600	0.053928	
24	1465	255.8704984	4	28	23	626.087	0.056273	
25	1529	267.0484587	5	28	26	692.3077	0.062225	

Figure 48: Data for 0.2M H<sub>2</sub>SO<sub>4</sub> Silent

H2SO4	0.3M							
Unsonicated	Contact Area (cm2)	6.668030407					Production Rate	
Voltage (V)	Applied Current (mA)	Current Density (mA/cm2)	Vol (cm3)	Temp (oC)	Time (s)	cm3/hour	g/hour	
1	0	0	0	28		#DIV/0!	#DIV/0!	
2	2	0.299938644	0	28		#DIV/0!	#DIV/0!	
3	45	6.748619495	0	28		#DIV/0!	#DIV/0!	
4	126	18.89613459	1	28	80	45	0.004045	
5	227	34.04303612	1	28	57	63.15789	0.005677	
6	337	50.53966155	1	28	30	120	0.010786	
7	440	65.98650173	2	28	43	167.4419	0.01505	
8	560	83.98282038	3	28	48	225	0.020223	
9	672	100.7793845	3	28	40	270	0.024268	
10	774	116.0762553	4	28	43	334.8837	0.030099	
11	893	133.9226046	4	28	40	360	0.032357	
12	1006	150.869138	4	28	34	423.5294	0.038067	
13	1118	167.6657021	5	28	36	500	0.04494	
14	1232	184.7622048	5	28	34	529.4118	0.047584	
15	1358	203.6583394	5	28	30	600	0.053928	
16	1496	224.3541059	6	28	34	635.2941	0.0571	
17	1595	239.2010688	5	28	26	692.3077	0.062225	
18	1736	260.3467432	5	28	24	750	0.06741	
19	1835	275.1937061	5	28	22	818.1818	0.073538	
20	1940	290.9404849	5	28	21	857.1429	0.07704	
21		0		28		#DIV/0!	#DIV/0!	
22		0		28		#DIV/0!	#DIV/0!	
23		0		28		#DIV/0!	#DIV/0!	
24		0		28		#DIV/0!	#DIV/0!	
25		0		28		#DIV/0!	#DIV/0!	

Figure 49: Data for 0.3M H<sub>2</sub>SO<sub>4</sub> Silent

H2SO4		0.4M						
Unsonicated	Contact Area (cm2)	6.668030407					Production Rate	
Voltage (V)	Applied Current (mA)	Current Density (mA/cm2)	Vol (cm3)	Temp (oC)	Time (s)	cm3/hour	g/hour	
1	0	0		28		#DIV/0!	#DIV/0!	
2	2	0.299938644		28		#DIV/0!	#DIV/0!	
3	52	7.79840475	1	28		#DIV/0!	#DIV/0!	
4	163	24.4449995	1	28	83	43.37349	0.003898	
5	290	43.49110341	2	28	79	91.13924	0.008192	
6	425	63.7369619	2	28	46	156.5217	0.014068	
7	563	84.43272835	3	28	47	229.7872	0.020653	
8	704	105.5784028	3	28	37	291.8919	0.026235	
9	848	127.1739852	4	28	39	369.2308	0.033186	
10	994	149.0695062	5	28	45	400	0.035952	
11	1148	172.1647818	5	28	33	545.4545	0.049025	
12	1300	194.9601187	5	28	30	600	0.053928	
13	1442	216.2557625	5	28	27	666.6667	0.05992	
14	1604	240.5507927	5	28	25	720	0.064714	
15	1739	260.7966512	5	28	23	782.6087	0.070341	
16	1959	293.789902	5	28	22	818.1818	0.073538	
17		0		28		#DIV/0!	#DIV/0!	
18		0		28		#DIV/0!	#DIV/0!	
19		0		28		#DIV/0!	#DIV/0!	
20		0		28		#DIV/0!	#DIV/0!	
21		0		28		#DIV/0!	#DIV/0!	
22		0		28		#DIV/0!	#DIV/0!	
23		0		28		#DIV/0!	#DIV/0!	
24		0		28		#DIV/0!	#DIV/0!	
25		0		28		#DIV/0!	#DIV/0!	

Figure 50: Data for 0.4M H<sub>2</sub>SO<sub>4</sub> Silent

H2SO4	0.5M							
Unsonicated	Contact Area (cm2)	5.725552611					Production Rate	
Voltage (V)	Applied Current (mA)	Current Density (mA/cm2)	Vol (cm3)	Temp (oC)	Time (s)	cm3/hour	g/hour	
1	0	0		28		#DIV/0!	#DIV/0!	
2	2	0.349311261		28		#DIV/0!	#DIV/0!	
3	52	9.082092775		28		#DIV/0!	#DIV/0!	
4	170	29.69145715	1	28	88	40.90909	0.003677	
5	309	53.96858976	2	28	58	124.1379	0.011158	
6	462	80.69090119	3	28	64	168.75	0.015167	
7	629	109.8583914	3	28	47	229.7872	0.020653	
8	793	138.5019148	4	28	45	320	0.028762	
9	958	167.3200938	5	28	44	409.0909	0.036769	
10	1148	200.5046636	5	28	37	486.4865	0.043725	
11	1392	243.1206373	5	28	33	545.4545	0.049025	
12	1456	254.2985977	5	28	30	600	0.053928	
13	1630	284.6886774	5	28	26	692.3077	0.062225	
14	1796	313.681512	5	28	24	750	0.06741	
15	1970	344.0715916	5	28	23	782.6087	0.070341	
16		0		28		#DIV/0!	#DIV/0!	
17		0		28		#DIV/0!	#DIV/0!	
18		0		28		#DIV/0!	#DIV/0!	
19		0		28		#DIV/0!	#DIV/0!	
20		0		28		#DIV/0!	#DIV/0!	
21		0		28		#DIV/0!	#DIV/0!	
22		0		28		#DIV/0!	#DIV/0!	
23		0		28		#DIV/0!	#DIV/0!	
24		0		28		#DIV/0!	#DIV/0!	
25		0		28		#DIV/0!	#DIV/0!	

Figure 51: Data for 0.5M H<sub>2</sub>SO<sub>4</sub> Silent

H2SO4	1.0M							
Unsonicated	Contact Area (cm2)	5.725552611					Production Rate	
Voltage (V)	Applied Current (mA)	Current Density (mA/cm2)	Vol (cm3)	Temp (oC)	Time (s)	cm3/hour	g/hour	
1	0	0		30		#DIV/0!	#DIV/0!	
2	7	1.222589412		30		#DIV/0!	#DIV/0!	
3	86	15.0203842		30		#DIV/0!	#DIV/0!	
4	284	49.602199	2	30	68	105.8824	0.009517	
5	551	96.23525228	3	30	49	220.4082	0.01981	
6	862	150.5531533	3	30	29	372.4138	0.033473	
7	1159	202.4258755	5	30	34	529.4118	0.047584	
8	1477	257.9663659	5	30	28	642.8571	0.05778	
9	1789	312.4589226	5	30	23	782.6087	0.070341	
10		0		30		#DIV/0!	#DIV/0!	
11		0		30		#DIV/0!	#DIV/0!	
12		0		30		#DIV/0!	#DIV/0!	
13		0		30		#DIV/0!	#DIV/0!	
14		0		30		#DIV/0!	#DIV/0!	
15		0		30		#DIV/0!	#DIV/0!	
16		0		30		#DIV/0!	#DIV/0!	
17		0		30		#DIV/0!	#DIV/0!	
18		0		30		#DIV/0!	#DIV/0!	
19		0		30		#DIV/0!	#DIV/0!	
20		0		30		#DIV/0!	#DIV/0!	
21		0		30		#DIV/0!	#DIV/0!	
22		0		30		#DIV/0!	#DIV/0!	
23		0		30		#DIV/0!	#DIV/0!	
24		0		30		#DIV/0!	#DIV/0!	
25		0		30		#DIV/0!	#DIV/0!	

Figure 52: Data for 1.0M H<sub>2</sub>SO<sub>4</sub> Silent



H2SO4												
Unsonicated	0.1M		0.2M		0.3M		0.4M		0.5M		1.0M	
Voltage (V)	V ideal	Efficiency (%)	V ideal	Efficiency (%)	V ideal	Efficiency (%)	V ideal	Efficiency (%)	V ideal	Efficiency (%)	V ideal	Efficiency (%)
1	0	#DIV/0!	0	#DIV/0!	0	#DIV/0!	0	#DIV/0!	0	#DIV/0!	0	#DIV/0!
2	0	#DIV/0!	0	#DIV/0!	0	#DIV/0!	0	#DIV/0!	0	#DIV/0!	0	#DIV/0!
3	0	#DIV/0!	0	#DIV/0!	0	#DIV/0!	0	#DIV/0!	0	#DIV/0!	0	#DIV/0!
4	0	#DIV/0!	0	#DIV/0!	1.961393	50.98418552	2.632508	37.98659103	3.390125	29.49743566	4.405408	45.39874985
5	0	#DIV/0!	3.355	29.80625717	2.517704	39.71872557	4.457887	44.86430293	4.061352	49.24468669	6.158948	48.70961835
6	4.008596	24.94639047	2.380792	42.002821	1.96723	50.83289714	3.80409	52.57499643	6.700483	44.77289341	5.702484	52.60864812
7	3.32386	30.08550463	2.991287	33.43042708	3.681503	54.32564377	5.14885	58.26543858	6.69935	44.78046586	8.989203	55.62228196
8	2.97867	33.57202705	5.347605	37.39991842	5.23038	57.35720872	5.068487	59.18925715	8.086672	49.46410396	9.434033	52.99960448
9	2.320981	43.0852272	4.73847	42.20771281	5.23038	57.35720872	6.435235	62.15778787	9.552176	52.3440925	9.386356	53.268808
10	2.258909	44.26915239	4.341898	46.0628014	6.476098	61.76558982	8.703679	57.44696961	9.625599	51.9448203	0	#DIV/0!
11	2.312809	43.23747182	5.917309	50.69871754	6.95049	57.54989811	7.371567	67.82818473	10.40968	48.03222281	0	#DIV/0!
12	2.289459	43.67844553	6.302098	47.60319713	6.655503	60.10064204	7.588721	65.88725514	9.89844	50.51300795	0	#DIV/0!
13	2.123285	47.09682827	6.373707	47.06836778	7.83156	63.84423948	7.575879	65.99894566	9.603844	52.06248672	0	#DIV/0!
14	3.642586	54.90604595	6.16749	48.6421558	8.150676	61.34460825	7.802762	64.07987408	9.767912	51.18801473	0	#DIV/0!
15	3.80409	52.57499643	6.519646	46.01476928	7.927295	63.07321921	7.78272	64.24489213	10.26782	48.69583287	0	#DIV/0!
16	3.92979	50.89330462	6.700483	44.77289341	9.897249	60.62290698	8.386121	59.62232471	0	#DIV/0!	0	#DIV/0!
17	3.756222	53.24498447	6.161145	48.69225071	8.06934	61.96293587	0	#DIV/0!	0	#DIV/0!	0	#DIV/0!
18	3.650369	54.78897549	8.320083	48.0764415	8.107089	61.67441797	0	#DIV/0!	0	#DIV/0!	0	#DIV/0!
19	3.54296	56.44997694	8.521542	46.93986144	7.855299	63.65129924	0	#DIV/0!	0	#DIV/0!	0	#DIV/0!
20	3.442166	58.1029497	8.622158	46.39209813	7.927295	63.07321921	0	#DIV/0!	0	#DIV/0!	0	#DIV/0!
21	3.283387	60.91271662	8.774215	45.58812339	0	#DIV/0!	0	#DIV/0!	0	#DIV/0!	0	#DIV/0!
22	5.269297	56.93359565	7.529205	53.12645748	0	#DIV/0!	0	#DIV/0!	0	#DIV/0!	0	#DIV/0!
23	4.903481	61.18102263	7.619624	52.4960311	0	#DIV/0!	0	#DIV/0!	0	#DIV/0!	0	#DIV/0!
24	4.880131	61.4737548	7.635713	52.38541474	0	#DIV/0!	0	#DIV/0!	0	#DIV/0!	0	#DIV/0!
25	8.044044	49.72623029	9.008759	55.50153914	0	#DIV/0!	0	#DIV/0!	0	#DIV/0!	0	#DIV/0!

Figure 53: Data of H<sub>2</sub>SO<sub>4</sub> Efficiency of H<sub>2</sub> production

Sonicated

NaOH	0.1M							
Sonicated	Contact Area (cm <sup>2</sup> )	6.668030407					Production Rate	
Voltage (V)	Applied Current (mA)	Current Density (mA/cm <sup>2</sup> )	Vol (cm <sup>3</sup> )	Temp (oC)	Time (s)	cm <sup>3</sup> /hour	g/hour	
1	0	0	0			#DIV/0!	#DIV/0!	
2	3	0.449907966	0			#DIV/0!	#DIV/0!	
3	17	2.549478476	0			#DIV/0!	#DIV/0!	
4	35	5.248926274	0			#DIV/0!	#DIV/0!	
5	54	8.098343394	0			#DIV/0!	#DIV/0!	
6	74	11.09772984	0	24.8		#DIV/0!	#DIV/0!	
7	98	14.69699357	1	24.5	188	19.14894	0.001721	
8	115	17.24647204	1	24.6	146	24.65753	0.002216	
9	134	20.09588916	1	24.7	112	32.14286	0.002889	
10	154	23.09527561	1	24.6	91	39.56044	0.003556	
11	171	25.64475408	1	24.6	85	42.35294	0.003807	
12	189	28.34420188	1	24.6	65	55.38462	0.004978	
13	208	31.193619	1	24.5	59	61.01695	0.005484	
14	226	33.8930668	1	24.6	53	67.92453	0.006105	
15	247	37.04242256	1	24.7	42	85.71429	0.007704	
16	266	39.89183968	1	25.6	39	92.30769	0.008297	
17	294	44.0909807	2	24.5	68	105.8824	0.009517	
18	314	47.09036714	2	24.5	60	120	0.010786	
19	337	50.53966155	2	24.2	58	124.1379	0.011158	
20	357	53.53904799	2	24.2	54	133.3333	0.011984	
21	372	55.78858783	2	24.2	53	135.8491	0.01221	
22	392	58.78797427	2	24	50	144	0.012943	
23	410	61.48742207	2	24.6	47	153.1915	0.013769	
24	430	64.48680851	2	24.5	42	171.4286	0.015408	
25	444	66.58637902	3	24.3	57	189.4737	0.01703	

Figure 54: Data for 0.1M NaOH Sonicated

NaOH	0.2M							
Sonicated	Contact Area (cm2)	4.783074815					Production Rate	
Voltage (V)	Applied Current (mA)	Current Density (mA/cm2)	Vol (cm3)	Temp (oC)	Time (s)	cm3/hour	g/hour	
1	0	0	0			#DIV/0!	#DIV/0!	
2	5	1.045352664	0			#DIV/0!	#DIV/0!	
3	31	6.481186517	0			#DIV/0!	#DIV/0!	
4	69	14.42586676	0			#DIV/0!	#DIV/0!	
5	107	22.37054701	1	26.8	112	32.14286	0.002889	
6	147	30.73336832	1	26.8	96	37.5	0.003371	
7	187	39.09618963	1	26.8	80	45	0.004045	
8	227	47.45901094	1	26.9	54	66.66667	0.005992	
9	266	55.61276172	1	27	42	85.71429	0.007704	
10	309	64.60279463	1	27.4	34	105.8824	0.009517	
11	354	74.01096861	2	27.3	57	126.3158	0.011353	
12	400	83.62821312	2	27.4	49	146.9388	0.013207	
13	438	91.57289337	2	27.4	42	171.4286	0.015408	
14	494	103.2808432	2	27.5	36	200	0.017976	
15	521	108.9257476	3	27.5	54	200	0.017976	
16	564	117.9157805	3	27.5	48	225	0.020223	
17	606	126.6967429	3	27.5	45	240	0.021571	
18	650	135.8958463	4	27.5	65	221.5385	0.019912	
19	686	143.4223855	4	28	50	288	0.025885	
20	745	155.7575469	4	27.3	46	313.0435	0.028136	
21	777	162.447804	4	27.3	42	342.8571	0.030816	
22	831	173.7376128	4	27.5	42	342.8571	0.030816	
23	856	178.9643761	4	27.1	37	389.1892	0.03498	
24	896	187.3271974	4	27.1	49	293.8776	0.026414	
25	930	194.4355955	5	27	48	375	0.033705	

Figure 55: Data for 0.2M NaOH Sonicated

NaOH	0.3M							
Sonicated	Contact Area (cm <sup>2</sup> )	4.783074815					Production Rate	
Voltage (V)	Applied Current (mA)	Current Density (mA/cm <sup>2</sup> )	Vol (cm <sup>3</sup> )	Temp (oC)	Time (s)	cm <sup>3</sup> /hour	g/hour	
1	0	0				#DIV/0!	#DIV/0!	
2	5	1.045352664				#DIV/0!	#DIV/0!	
3	33	6.899327582				#DIV/0!	#DIV/0!	
4	75	15.68028996				#DIV/0!	#DIV/0!	
5	118	24.67032287				#DIV/0!	#DIV/0!	
6	162	33.86942631	1	27.3	110	32.72727	0.002942	
7	206	43.06852976	1	27.2	78	46.15385	0.004148	
8	250	52.2676332	1	27.2	57	63.15789	0.005677	
9	297	62.09394824	1	27.1	51	70.58824	0.006344	
10	343	71.71119275	1	27.4	48	75	0.006741	
11	388	81.11936673	1	27.3	46	78.26087	0.007034	
12	440	91.99103443	2	27.9	50	144	0.012943	
13	485	101.3992084	2	27.9	38	189.4737	0.01703	
14	533	111.434594	2	27.9	36	200	0.017976	
15	578	120.842768	3	28	51	211.7647	0.019033	
16	628	131.2962946	3	28	46	234.7826	0.021102	
17	676	141.3316802	3	28	42	257.1429	0.023112	
18	719	150.3217131	3	27.9	39	276.9231	0.02489	
19	769	160.7752397	3	28.1	38	284.2105	0.025545	
20	820	171.4378369	4	27.8	47	306.383	0.027538	
21	862	180.2187993	4	27.8	45	320	0.028762	
22	908	189.8360438	4	27.9	40	360	0.032357	
23	956	199.8714294	4	27.8	36	400	0.035952	
24	1005	210.1158855	4	28	34	423.5294	0.038067	
25	1059	221.4056942	5	27.6	43	418.6047	0.037624	

Figure 56: Data for 0.3M NaOH Sonicated

NaOH	0.4M							
Sonicated	Contact Area (cm2)	5.725552611					Production Rate	
Voltage (V)	Applied Current (mA)	Current Density (mA/cm2)	Vol (cm3)	Temp (oC)	Time (s)	cm3/hour	g/hour	
1	0	0				#DIV/0!	#DIV/0!	
2	4	0.698622521				#DIV/0!	#DIV/0!	
3	44	7.684847732				#DIV/0!	#DIV/0!	
4	98	17.11625177				#DIV/0!	#DIV/0!	
5	155	27.07162269	1	25.8	88	40.90909	0.003677	
6	213	37.20164925	1	25.8	68	52.94118	0.004758	
7	272	47.50633144	1	25.8	51	70.58824	0.006344	
8	330	57.63635799	1	25.8	34	105.8824	0.009517	
9	387	67.59172892	2	25.9	57	126.3158	0.011353	
10	448	78.24572237	2	25.8	48	150	0.013482	
11	508	88.72506018	2	25.8	38	189.4737	0.01703	
12	568	99.204398	2	26	34	211.7647	0.019033	
13	628	109.6837358	3	26.4	47	229.7872	0.020653	
14	687	119.988418	3	26.2	41	263.4146	0.023676	
15	748	130.6424114	3	25.9	34	317.6471	0.02855	
16	805	140.5977824	4	25.8	47	306.383	0.027538	
17	859	150.0291864	4	25.9	43	334.8837	0.030099	
18	925	161.556458	4	25.8	38	378.9474	0.03406	
19	984	171.8611402	4	26.6	37	389.1892	0.03498	
20	1053	183.9123787	5	26.6	42	428.5714	0.03852	
21	1099	191.9465377	5	25.6	40	450	0.040446	
22	1163	203.124498	5	25.8	38	473.6842	0.042575	
23	1233	215.3503921	5	25.3	36	500	0.04494	
24	1269	221.6379948	5	25.1	35	514.2857	0.046224	
25	1328	231.942677	5	25.3	34	529.4118	0.047584	

Figure 57: Data for 0.4M NaOH Sonicated

NaOH	0.5M							
Sonicated	Contact Area (cm2)	5.725552611					Production Rate	
Voltage (V)	Applied Current (mA)	Current Density (mA/cm2)	Vol (cm3)	Temp (oC)	Time (s)	cm3/hour	g/hour	
1	0	0				#DIV/0!	#DIV/0!	
2	6	1.047933782				#DIV/0!	#DIV/0!	
3	53	9.256748405				#DIV/0!	#DIV/0!	
4	184	32.13663597	1	27	89	40.44944	0.003636	
5	199	34.75647043	1	27	65	55.38462	0.004978	
6	271	47.33167581	1	27	43	83.72093	0.007525	
7	354	61.82809312	1	27	30	120	0.010786	
8	428	74.75260976	2	27.1	48	150	0.013482	
9	505	88.20109329	2	27.2	38	189.4737	0.01703	
10	582	101.6495768	3	27.1	49	220.4082	0.01981	
11	658	114.9234047	3	27.1	47	229.7872	0.020653	
12	750	130.9917227	4	27.2	47	306.383	0.027538	
13	828	144.6148619	5	27.4	54	333.3333	0.02996	
14	915	159.8099017	5	27.5	48	375	0.033705	
15	990	172.909074	5	27.4	43	418.6047	0.037624	
16	1073	187.4054913	5	27.1	42	428.5714	0.03852	
17	1161	202.7751868	5	27.5	37	486.4865	0.043725	
18	1241	216.7476372	5	27.8	34	529.4118	0.047584	
19	1309	228.62422	5	26.5	33	545.4545	0.049025	
20	1350	235.7851009	5	26.3	27	666.6667	0.05992	
21	1467	256.2198096	5	25.8	25	720	0.064714	
22	1554	271.4148495	5	25.8	23	782.6087	0.070341	
23		0				#DIV/0!	#DIV/0!	
24		0				#DIV/0!	#DIV/0!	
25		0				#DIV/0!	#DIV/0!	

Figure 58: Data for 0.5M NaOH Sonicated

NaOH	1.0M							
Sonicated	Contact Area (cm2)	5.725552611					Production Rate	
Voltage (V)	Applied Current (mA)	Current Density (mA/cm2)	Vol (cm3)	Temp (oC)	Time (s)	cm3/hour	g/hour	
1	0	0				#DIV/0!	#DIV/0!	
2	6	1.047933782				#DIV/0!	#DIV/0!	
3	95	16.59228488				#DIV/0!	#DIV/0!	
4	216	37.72561614	1	27.4	55	65.45455	0.005883	
5	346	60.43084808	1	27.5	31	116.129	0.010438	
6	477	83.31073564	3	27.5	57	189.4737	0.01703	
7	611	106.7145901	3	27.5	53	203.7736	0.018315	
8	751	131.1663783	4	27.7	47	306.383	0.027538	
9	872	152.2997096	4	28	42	342.8571	0.030816	
10	1023	178.6727098	5	28	40	450	0.040446	
11	1157	202.0765642	5	28.2	36	500	0.04494	
12	1261	220.2407498	5	27.9	32	562.5	0.050558	
13	1395	243.6446042	5	28.3	30	600	0.053928	
14	1490	260.2368891	5	28.2	29	620.6897	0.055788	
15	1622	283.2914323	5	28.3	24	750	0.06741	
16	1796	313.681512	5	28.3	22	818.1818	0.073538	
17	1840	321.3663597	5	28.1	21	857.1429	0.07704	
18		0				#DIV/0!	#DIV/0!	
19		0				#DIV/0!	#DIV/0!	
20		0				#DIV/0!	#DIV/0!	
21		0				#DIV/0!	#DIV/0!	
22		0				#DIV/0!	#DIV/0!	
23		0				#DIV/0!	#DIV/0!	
24		0				#DIV/0!	#DIV/0!	
25		0				#DIV/0!	#DIV/0!	

Figure 59: Data for 1.0M NaOH Sonicated

NaOH												
Sonicated	0.1M		0.2M		0.3M		0.4M		0.5M		1.0M	
Voltage (V)	V ideal	Efficiency (%)	V ideal	Efficiency (%)	V ideal	Efficiency (%)	V ideal	Efficiency (%)	V ideal	Efficiency (%)	V ideal	Efficiency
1	0	#DIV/0!	0	#DIV/0!	0	#DIV/0!	0	#DIV/0!	0	#DIV/0!	0	#DIV/0!
2	0	#DIV/0!	0	#DIV/0!	0	#DIV/0!	0	#DIV/0!	0	#DIV/0!	0	#DIV/0!
3	0	#DIV/0!	0	#DIV/0!	0	#DIV/0!	0	#DIV/0!	0	#DIV/0!	0	#DIV/0!
4	0	#DIV/0!	0	#DIV/0!	0	#DIV/0!	0	#DIV/0!	3.698686	27.03662928	2.686794	37.21907
5	0	#DIV/0!	3.237891	30.88430418	0	#DIV/0!	3.068416	32.59010768	2.921501	34.22897883	2.426612	41.20973
6	0	#DIV/0!	3.812843	26.2271472	4.822713	20.73521676	3.25828	30.69104314	2.631948	37.99466585	6.151142	48.77144
7	3.543324	28.22208357	4.04196	24.74047469	4.347113	23.00377062	3.120606	32.04505974	2.398635	41.69038052	7.326213	40.94885
8	3.230157	30.95825115	3.313025	30.1838921	3.855263	25.93856746	2.524019	39.61934659	4.641617	43.08843264	7.990778	50.0577
9	2.888295	34.62250287	3.020514	33.10695306	4.096577	24.41062204	4.96399	40.29016925	4.337144	46.11328996	8.299462	48.1959
10	2.696094	37.09069764	2.844236	35.15882552	4.457215	22.43553334	4.837479	41.3438494	6.443226	46.56052809	9.27299	53.92004
11	2.796327	35.76119964	5.46087	36.62420088	4.830291	20.70268729	4.342573	46.05564326	6.987278	42.93517235	9.445139	52.93729
12	2.363459	42.31086991	5.306209	37.69169601	5.965857	33.52410337	4.347279	46.00578646	7.966876	50.20788847	9.141237	54.69719
13	2.360165	42.36992077	4.980256	40.15858023	4.997761	40.01792046	6.653162	45.09134114	10.11212	49.4456282	9.493187	52.66935
14	2.304396	43.39531114	4.816174	41.52673874	5.203312	38.43705827	6.344847	47.28246633	9.936303	50.32052786	9.798436	51.02855
15	1.99648	50.0881553	7.619109	39.37468127	7.996361	37.51706541	5.723024	52.41983584	9.62768	51.93359004	8.830365	56.6228
16	2.002513	49.93726211	7.331504	40.91929975	7.836314	38.2833029	8.511254	46.99659773	10.182	49.10624196	8.962839	55.7859
17	3.844884	52.01717364	7.385125	40.62219592	7.701767	38.95210109	8.312022	48.12306595	9.718437	51.44860171	8.75922	57.08271
18	3.62333	55.19784159	11.44193	34.95912529	7.604027	39.45278026	7.907244	50.58652276	9.555344	52.32674036	0	#DIV/0!
19	3.75532	53.2577781	9.304403	42.99040056	7.929549	37.83317163	8.212158	48.70826953	9.740228	51.33349802	0	#DIV/0!
20	3.70383	53.99816012	9.274656	43.12828278	10.44762	38.28621388	9.975579	50.1224019	8.213403	60.87610785	0	#DIV/0!
21	3.787982	52.79856618	8.831898	45.29037969	10.5154	38.03946076	9.882501	50.59447924	8.250304	60.60382669	0	#DIV/0!
22	3.763162	53.14679445	9.451985	42.31915201	9.849087	40.61290056	9.941757	50.29292085	8.040419	62.18581344	0	#DIV/0!
23	3.707273	53.94800589	8.565841	46.69710684	9.329669	42.87397382	9.968698	50.1570017	0	#DIV/0!	0	#DIV/0!
24	3.47332	57.58180152	11.87404	33.68692529	9.269138	43.15395783	9.968077	50.16012488	0	#DIV/0!	0	#DIV/0!
25	4.863993	61.67772427	12.06908	41.42818992	12.3362	40.53110466	10.14028	49.30831395	0	#DIV/0!	0	#DIV/0!

Figure 60: Data of NaOH Efficiency of H<sub>2</sub> production



NaCl	0.1M							
Sonicated	Contact Area (cm2)	6.668030407					Production Rate	
Voltage (V)	Applied Current (mA)	Current Density (mA/cm2)	Vol (cm3)	Temp (oC)	Time (s)	cm3/hour	g/hour	
1	0	0				#DIV/0!	#DIV/0!	
2	0	0				#DIV/0!	#DIV/0!	
3	0	0				#DIV/0!	#DIV/0!	
4	0	0				#DIV/0!	#DIV/0!	
5	0	0				#DIV/0!	#DIV/0!	
6	2	0.299938644				#DIV/0!	#DIV/0!	
7	5	0.749846611				#DIV/0!	#DIV/0!	
8	17	2.549478476				#DIV/0!	#DIV/0!	
9	35	5.248926274				#DIV/0!	#DIV/0!	
10	44	6.598650173				#DIV/0!	#DIV/0!	
11	55	8.248312716				#DIV/0!	#DIV/0!	
12	68	10.1979139				#DIV/0!	#DIV/0!	
13	81	12.14751509				#DIV/0!	#DIV/0!	
14	93	13.94714696				#DIV/0!	#DIV/0!	
15	104	15.5968095				#DIV/0!	#DIV/0!	
16	116	17.39644137	1	26.2	123	29.26829	0.002631	
17	128	19.19607323	1	26	113	31.85841	0.002863	
18	138	20.69576645	1	25.5	106	33.96226	0.003053	
19	149	22.34542899	1	25.6	103	34.95146	0.003141	
20	157	23.54518357	1	25.5	95	37.89474	0.003406	
21	167	25.04487679	1	25.1	89	40.44944	0.003636	
22	176	26.39460069	1	25.1	74	48.64865	0.004373	
23	186	27.89429391	1	25	72	50	0.004494	
24	193	28.94407917	1	24.9	67	53.73134	0.004829	
25	202	30.29380307	1	24.8	61	59.01639	0.005304	

Figure 61: Data for 0.1M NaCl Sonicated

NaCl	0.2M							
Sonicated	Contact Area (cm2)	6.668030407					Production Rate	
Voltage (V)	Applied Current (mA)	Current Density (mA/cm2)	Vol (cm3)	Temp (oC)	Time (s)	cm3/hour	g/hour	
1	0	0				#DIV/0!	#DIV/0!	
2	2	0.299938644				#DIV/0!	#DIV/0!	
3	6	0.899815933				#DIV/0!	#DIV/0!	
4	20	2.999386442				#DIV/0!	#DIV/0!	
5	37	5.548864918				#DIV/0!	#DIV/0!	
6	55	8.248312716				#DIV/0!	#DIV/0!	
7	74	11.09772984				#DIV/0!	#DIV/0!	
8	93	13.94714696				#DIV/0!	#DIV/0!	
9	112	16.79656408				#DIV/0!	#DIV/0!	
10	131	19.6459812	1	26.2	137	26.27737	0.002362	
11	150	22.49539832	1	26.2	112	32.14286	0.002889	
12	173	25.94469273	1	26.2	96	37.5	0.003371	
13	189	28.34420188	1	26.3	81	44.44444	0.003995	
14	205	30.74371103	1	26.6	72	50	0.004494	
15	233	34.94285205	1	26.1	58	62.06897	0.005579	
16	252	37.79226917	1	26.3	49	73.46939	0.006603	
17	268	40.19177833	1	25.8	43	83.72093	0.007525	
18	286	42.89122612	1	26	42	85.71429	0.007704	
19	308	46.19055121	1	25.7	41	87.80488	0.007892	
20	325	48.74002969	1	25.5	40	90	0.008089	
21	346	51.88938545	2	26.3	62	116.129	0.010438	
22	362	54.2888946	2	26	55	130.9091	0.011766	
23	382	57.28828105	2	25.8	53	135.8491	0.01221	
24	405	60.73757546	2	25.5	49	146.9388	0.013207	
25	424	63.58699258	2	27.6	48	150	0.013482	

Figure 62: Data for 0.2M NaCl Sonicated

NaCl	0.3M							
Sonicated	Contact Area (cm2)	4.783074815					Production Rate	
Voltage (V)	Applied Current (mA)	Current Density (mA/cm2)	Vol (cm3)	Temp (oC)	Time (s)	cm3/hour	g/hour	
1	0	0				#DIV/0!	#DIV/0!	
2	1	0.209070533				#DIV/0!	#DIV/0!	
3	8	1.672564262				#DIV/0!	#DIV/0!	
4	28	5.853974918				#DIV/0!	#DIV/0!	
5	53	11.08073824				#DIV/0!	#DIV/0!	
6	79	16.51657209				#DIV/0!	#DIV/0!	
7	105	21.95240594				#DIV/0!	#DIV/0!	
8	134	28.01545139	1	27.3	120	30	0.002696	
9	160	33.45128525	1	27.5	95	37.89474	0.003406	
10	190	39.72340123	1	27.5	70	51.42857	0.004622	
11	221	46.20458775	1	27.5	57	63.15789	0.005677	
12	249	52.05856267	1	27.6	56	64.28571	0.005778	
13	280	58.53974918	1	27.5	46	78.26087	0.007034	
14	308	64.3937241	1	27.7	45	80	0.00719	
15	340	71.08398115	1	27.8	43	83.72093	0.007525	
16	372	77.7742382	1	27.8	32	112.5	0.010112	
17	400	83.62821312	1	27.9	31	116.129	0.010438	
18	435	90.94568177	1	27.9	26	138.4615	0.012445	
19	476	99.51757361	2	28.1	48	150	0.013482	
20	488	102.02642	2	27.7	42	171.4286	0.015408	
21	519	108.5076065	2	27.5	39	184.6154	0.016593	
22	549	114.7797225	2	27.7	37	194.5946	0.01749	
23	579	121.0518385	2	27.5	35	205.7143	0.01849	
24	609	127.3239545	2	27.4	32	225	0.020223	
25	646	135.0595642	2	27.3	30	240	0.021571	

Figure 63: Data for 0.3M NaCl Sonicated

NaCl	0.4M							
Sonicated	Contact Area (cm2)	5.725552611					Production Rate	
Voltage (V)	Applied Current (mA)	Current Density (mA/cm2)	Vol (cm3)	Temp (oC)	Time (s)	cm3/hour	g/hour	
1		0				#DIV/0!	#DIV/0!	
2	1	0.17465563				#DIV/0!	#DIV/0!	
3	9	1.571900673				#DIV/0!	#DIV/0!	
4	37	6.46225832				#DIV/0!	#DIV/0!	
5	70	12.22589412				#DIV/0!	#DIV/0!	
6	103	17.98952992				#DIV/0!	#DIV/0!	
7	139	24.27713261	1	26.8	139	25.89928	0.002328	
8	178	31.08870219	1	26.8	92	39.13043	0.003517	
9	215	37.55096051	1	26.9	66	54.54545	0.004903	
10	257	44.88649698	1	27	51	70.58824	0.006344	
11	296	51.69806656	1	27.5	48	75	0.006741	
12	330	57.63635799	1	27.6	39	92.30769	0.008297	
13	369	64.44792757	1	27.8	28	128.5714	0.011556	
14	409	71.43415278	2	27.8	52	138.4615	0.012445	
15	450	78.59503363	2	28	45	160	0.014381	
16	485	84.70798069	2	28.1	39	184.6154	0.016593	
17	531	92.74213968	2	28	38	189.4737	0.01703	
18	569	99.37905363	2	28.2	37	194.5946	0.01749	
19	614	107.238557	2	28.3	35	205.7143	0.01849	
20	659	115.0980604	2	28.4	29	248.2759	0.022315	
21	690	120.5123849	3	27.9	43	251.1628	0.022575	
22	725	126.625332	3	27.9	41	263.4146	0.023676	
23	762	133.0875903	3	28.3	34	317.6471	0.02855	
24	808	141.1217493	4	28.2	45	320	0.028762	
25	844	147.409352	4	28.2	42	342.8571	0.030816	

Figure 64: Data for 0.4M NaCl Sonicated

NaCl	0.5M							
Sonicated	Contact Area (cm2)	5.254313713					Production Rate	
Voltage (V)	Applied Current (mA)	Current Density (mA/cm2)	Vol (cm3)	Temp (oC)	Time (s)	cm3/hour	g/hour	
1	0	0				#DIV/0!	#DIV/0!	
2	2	0.380639625				#DIV/0!	#DIV/0!	
3	13	2.474157561				#DIV/0!	#DIV/0!	
4	43	8.183751932				#DIV/0!	#DIV/0!	
5	78	14.84494536				#DIV/0!	#DIV/0!	
6	115	21.88677842				#DIV/0!	#DIV/0!	
7	154	29.3092511	1	27.6	203	17.73399	0.001594	
8	190	36.16076435	1	27.5	105	34.28571	0.003082	
9	232	44.15419647	1	27.6	84	42.85714	0.003852	
10	271	51.57666915	1	27.8	67	53.73134	0.004829	
11	316	60.14106071	1	27.8	45	80	0.00719	
12	353	67.18289377	1	27.9	39	92.30769	0.008297	
13	398	75.74728532	1	28.3	32	112.5	0.010112	
14	443	84.31167688	2	28.3	52	138.4615	0.012445	
15	486	92.49542881	2	28.4	43	167.4419	0.01505	
16	526	100.1082213	2	28.6	39	184.6154	0.016593	
17	571	108.6726129	2	28.8	37	194.5946	0.01749	
18	625	118.9498827	3	29	48	225	0.020223	
19	658	125.2304365	3	28.8	42	257.1429	0.023112	
20	702	133.6045083	3	28.8	39	276.9231	0.02489	
21	748	142.3592197	3	28.8	36	300	0.026964	
22	792	150.7332914	3	29.9	35	308.5714	0.027734	
23	833	158.5364037	4	28.9	45	320	0.028762	
24	884	168.2427141	4	28.7	44	327.2727	0.029415	
25	948	180.4231821	4	29.3	41	351.2195	0.031568	

Figure 65: Data for 0.5M NaCl Sonicated

NaCl	1.0M							
Sonicated	Contact Area (cm2)	6.668030407					Production Rate	
Voltage (V)	Applied Current (mA)	Current Density (mA/cm2)	Vol (cm3)	Temp (oC)	Time (s)	cm3/hour	g/hour	
1	1	0.149969322				#DIV/0!	#DIV/0!	
2	5	0.749846611				#DIV/0!	#DIV/0!	
3	21	3.149355764				#DIV/0!	#DIV/0!	
4	73	10.94776051				#DIV/0!	#DIV/0!	
5	143	21.44561306	1	27.7	134	26.86567	0.002415	
6	218	32.69331222	1	27.7	76	47.36842	0.004257	
7	294	44.0909807	1	28	46	78.26087	0.007034	
8	372	55.78858783	1	28.1	40	90	0.008089	
9	444	66.58637902	1	28.2	44	81.81818	0.007354	
10	520	77.9840475	2	28.3	40	180	0.016178	
11	609	91.33131717	2	28.4	32	225	0.020223	
12	696	104.3786482	3	28.5	40	270	0.024268	
13	772	115.7763167	4	28.7	51	282.3529	0.025378	
14	845	126.7240772	5	28.9	52	346.1538	0.031112	
15	942	141.2711014	5	28.9	45	400	0.035952	
16	1025	153.7185552	5	29	42	428.5714	0.03852	
17	1108	166.1660089	5	29.1	37	486.4865	0.043725	
18	1180	176.9638001	5	28.8	35	514.2857	0.046224	
19	1260	188.9613459	5	28.9	33	545.4545	0.049025	
20	1343	201.4087996	5	29	32	562.5	0.050558	
21	1447	217.0056091	5	28.9	29	620.6897	0.055788	
22	1510	226.4536764	5	28.5	28	642.8571	0.05778	
23	1582	237.2514676	5	28.8	28	642.8571	0.05778	
24	1673	250.8986759	5	28.5	27	666.6667	0.05992	
25	1714	257.0474181	5	28	26	692.3077	0.062225	

Figure 66: Data for 1.0M NaCl Sonicated

NaCl	0.1M		0.2M		0.3M		0.4M		0.5M		1.0M	
Sonicated	V ideal	Efficiency (%)	V ideal	Efficiency (%)	V ideal	Efficiency (%)	V ideal	Efficiency (%)	V ideal	Efficiency (%)	V ideal	Efficiency (%)
1	0	#DIV/0!	0	#DIV/0!	0	#DIV/0!	0	#DIV/0!	0	#DIV/0!	0	#DIV/0!
2	0	#DIV/0!	0	#DIV/0!	0	#DIV/0!	0	#DIV/0!	0	#DIV/0!	0	#DIV/0!
3	0	#DIV/0!	0	#DIV/0!	0	#DIV/0!	0	#DIV/0!	0	#DIV/0!	0	#DIV/0!
4	0	#DIV/0!	0	#DIV/0!	0	#DIV/0!	0	#DIV/0!	0	#DIV/0!	0	#DIV/0!
5	0	#DIV/0!	0	#DIV/0!	0	#DIV/0!	0	#DIV/0!	0	#DIV/0!	3.724877	26.84652221
6	0	#DIV/0!	0	#DIV/0!	0	#DIV/0!	0	#DIV/0!	0	#DIV/0!	3.220633	31.04979833
7	0	#DIV/0!	0	#DIV/0!	0	#DIV/0!	4.360936	22.93085545	7.70948	12.97104357	2.631535	38.00063517
8	0	#DIV/0!	0	#DIV/0!	4.351808	22.9789529	3.696221	27.05465671	4.918207	20.33261348	2.89635	34.52620928
9	0	#DIV/0!	0	#DIV/0!	4.116388	24.29314216	3.203888	31.21207896	4.80591	20.80771573	3.80389	26.28887752
10	0	#DIV/0!	3.471301	28.80764524	3.60184	27.76359105	2.960349	33.77980019	4.480651	22.31818492	4.05135	49.36626361
11	0	#DIV/0!	3.249449	30.77445292	3.411457	29.31299205	3.214367	31.11032635	3.509107	28.49727733	3.797062	52.67229934
12	0	#DIV/0!	3.212312	31.13022695	3.7775	26.47253174	2.912631	34.33322033	3.398448	29.42519632	5.426173	55.28757984
13	0	#DIV/0!	2.962049	33.76041254	3.488097	28.66892554	2.339807	42.73856916	3.148118	31.76500839	7.678913	52.09070319
14	0	#DIV/0!	2.858687	34.98108987	3.755993	26.62411875	4.816397	41.5248163	5.694099	35.12407943	8.575511	58.30556352
15	0	#DIV/0!	2.612999	38.27020704	3.963266	25.23171483	4.588906	43.5833716	5.167337	38.70465948	8.273007	60.43751972
16	2.75971	36.23568889	2.389142	41.85602167	3.226999	30.98854761	4.287802	46.64394966	5.075751	39.40303538	8.404597	59.49125564
17	2.795751	35.76856072	2.225989	44.92386134	3.362574	29.73912396	4.57259	43.73888764	5.23089	38.23441435	8.006246	62.45124429
18	2.822725	35.42675833	2.321803	43.06996856	3.066993	32.60522874	4.774044	41.89319979	7.432699	40.36218925	8.057609	62.05314596
19	2.96246	33.75572797	2.438422	41.01012113	6.19993	32.25843083	4.874757	41.02768529	6.84247	43.84381633	8.114924	61.614874
20	2.878107	34.74506341	2.508574	39.86327852	5.554317	36.00802946	4.336547	46.11964693	6.778591	44.256984	8.39015	59.59369312
21	2.864231	34.91338482	4.150622	48.185545	5.481566	36.48592075	6.721365	44.63379356	6.667174	44.99657264	8.189672	61.05250961
22	2.50984	39.84318478	3.84841	51.96950902	5.504725	36.33242612	6.733824	44.5512079	6.888271	43.55229582	8.240611	60.67511127
23	2.579891	38.76132649	3.91074	51.14122079	5.488066	36.44271018	5.876929	51.0470679	9.284084	43.08448926	8.642127	57.85612534
24	2.490247	40.15666592	3.829435	52.2270215	5.275887	37.90831495	8.245108	48.5136158	9.627174	41.54905807	8.804083	56.79182893
25	2.372169	42.15550451	3.954885	50.57037232	5.244903	38.13225621	8.0383	49.76176569	9.639366	41.49650511	8.671379	57.66095841

Figure 67: Data of NaCl Efficiency of H<sub>2</sub> production

H2SO4	0.1M							
Sonicated	Contact Area (cm2)	4.783074815					Production Rate	
Voltage (V)	Applied Current (mA)	Current Density (mA/cm2)	Vol (cm3)	Temp (oC)	Time (s)	cm3/hour	g/hour	
1	0	0				#DIV/0!	#DIV/0!	
2	2	0.418141066				#DIV/0!	#DIV/0!	
3	23	4.808622254				#DIV/0!	#DIV/0!	
4	59	12.33516144				#DIV/0!	#DIV/0!	
5	97	20.27984168				#DIV/0!	#DIV/0!	
6	135	28.22452193	1	27.9	104	34.61538	0.003111	
7	175	36.58734324	1	28.2	71	50.70423	0.004557	
8	215	44.95016455	1	28	56	64.28571	0.005778	
9	256	53.5220564	1	28	50	72	0.006471	
10	302	63.1393009	1	28.2	38	94.73684	0.008515	
11	337	70.45676955	1	28.5	33	109.0909	0.009805	
12	378	79.0286614	2	28.3	51	141.1765	0.012689	
13	420	87.80962377	2	28.3	44	163.6364	0.014708	
14	458	95.75430402	2	29.1	39	184.6154	0.016593	
15	502	104.9534075	2	29.3	38	189.4737	0.01703	
16	542	113.3162288	2	29.2	35	205.7143	0.01849	
17	585	122.3062617	3	29.3	48	225	0.020223	
18	622	130.0418714	3	29.5	44	245.4545	0.022061	
19	661	138.1956222	3	29.5	40	270	0.024268	
20	709	148.2310078	4	29.7	48	300	0.026964	
21	764	159.7298871	4	29.2	45	320	0.028762	
22	793	165.7929325	4	30	44	327.2727	0.029415	
23	835	174.5738949	4	29.5	43	334.8837	0.030099	
24	885	185.0274215	4	28.8	39	369.2308	0.033186	
25	919	192.1358196	4	30.2	35	411.4286	0.036979	

Figure 68: Data for 0.1M H<sub>2</sub>SO<sub>4</sub> Sonicated



H2SO4	0.2M							
Sonicated	Contact Area (cm2)	6.668030407					Production Rate	
Voltage (V)	Applied Current (mA)	Current Density (mA/cm2)	Vol (cm3)	Temp (oC)	Time (s)	cm3/hour	g/hour	
1		0				#DIV/0!	#DIV/0!	
2	1	0.149969322				#DIV/0!	#DIV/0!	
3	35	5.248926274				#DIV/0!	#DIV/0!	
4	94	14.09711628				#DIV/0!	#DIV/0!	
5	160	23.99509154	1	29.6	85	42.35294	0.003807	
6	227	34.04303612	1	29.6	50	72	0.006471	
7	295	44.24095002	1	29.7	46	78.26087	0.007034	
8	365	54.73880257	1	29.7	37	97.2973	0.008745	
9	438	65.68656309	2	30	47	153.1915	0.013769	
10	503	75.43456902	2	30.1	33	218.1818	0.01961	
11	580	86.98220683	2	30.4	30	240	0.021571	
12	620	92.98097971	3	30.5	41	263.4146	0.023676	
13	727	109.0276972	3	30.5	40	270	0.024268	
14	803	120.4253657	3	31.1	38	284.2105	0.025545	
15	876	131.3731262	4	31	52	276.9231	0.02489	
16	943	141.4210708	4	30.5	41	351.2195	0.031568	
17	1025	153.7185552	5	31.3	46	391.3043	0.03517	
18	1082	162.2668065	5	32.1	42	428.5714	0.03852	
19	1158	173.664475	5	31.7	37	486.4865	0.043725	
20	1240	185.9619594	5	31.5	35	514.2857	0.046224	
21	1300	194.9601187	5	31.3	32	562.5	0.050558	
22	1392	208.7572964	5	32.1	33	545.4545	0.049025	
23	1484	222.554474	5	32	32	562.5	0.050558	
24	1548	232.1525106	5	33	31	580.6452	0.052188	
25	1629	244.3000257	5	34	29	620.6897	0.055788	

Figure 69: Data for 0.2M H<sub>2</sub>SO<sub>4</sub> Sonicated

H2SO4	0.3M							
Sonicated	Contact Area (cm2)	5.725552611					Production Rate	
Voltage (V)	Applied Current (mA)	Current Density (mA/cm2)	Vol (cm3)	Temp (oC)	Time (s)	cm3/hour	g/hour	
1		0				#DIV/0!	#DIV/0!	
2	2	0.349311261				#DIV/0!	#DIV/0!	
3	47	8.208814623				#DIV/0!	#DIV/0!	
4	147	25.67437765	1	26.2	140	25.71429	0.002311	
5	217	37.90027177	1	26.4	78	46.15385	0.004148	
6	312	54.49255665	1	26.6	37	97.2973	0.008745	
7	408	71.25949715	1	26.9	30	120	0.010786	
8	506	88.37574892	2	26.9	40	180	0.016178	
9	604	105.4920007	3	27.4	48	225	0.020223	
10	698	121.9096299	3	27.5	37	291.8919	0.026235	
11	808	141.1217493	4	28.5	48	300	0.026964	
12	935	163.3030143	4	28.9	38	378.9474	0.03406	
13	1034	180.5939217	5	28.9	46	391.3043	0.03517	
14	1147	200.3300079	5	29	44	409.0909	0.036769	
15	1228	214.477114	5	29.1	39	461.5385	0.041483	
16	1325	231.4187101	5	29.3	38	473.6842	0.042575	
17	1445	252.3773858	5	29.7	37	486.4865	0.043725	
18	1531	267.39777	5	29.3	36	500	0.04494	
19	1630	284.6886774	5	29.5	34	529.4118	0.047584	
20	1782	311.2363332	5	30.2	30	600	0.053928	
21	1865	325.7327505	5	29.8	23	782.6087	0.070341	
22	1923	335.862777	5	29.7	22	818.1818	0.073538	
23		0				#DIV/0!	#DIV/0!	
24		0				#DIV/0!	#DIV/0!	
25		0				#DIV/0!	#DIV/0!	

Figure 70: Data for 0.3M H<sub>2</sub>SO<sub>4</sub> Sonicated

H2SO4	0.4M							
Sonicated	Contact Area (cm2)	5.725552611					Production Rate	
Voltage (V)	Applied Current (mA)	Current Density (mA/cm2)	Vol (cm3)	Temp (oC)	Time (s)	cm3/hour	g/hour	
1		0				#DIV/0!	#DIV/0!	
2	3	0.523966891				#DIV/0!	#DIV/0!	
3	50	8.732781514				#DIV/0!	#DIV/0!	
4	144	25.15041076	1	27.4	78	46.15385	0.004148	
5	252	44.01321883	1	27.6	43	83.72093	0.007525	
6	349	60.95481497	1	27.8	39	92.30769	0.008297	
7	473	82.61211312	2	28.2	41	175.6098	0.015784	
8	586	102.3481993	2	28.5	30	240	0.021571	
9	699	122.0842856	3	28.7	41	263.4146	0.023676	
10	810	141.4710605	3	28.9	33	327.2727	0.029415	
11	928	162.0804249	4	29.2	38	378.9474	0.03406	
12	1030	179.8952992	5	23	50	360	0.032357	
13	1164	203.2991536	5	29.9	37	486.4865	0.043725	
14	1276	222.8605842	5	30	33	545.4545	0.049025	
15	1402	244.8671937	5	30.9	31	580.6452	0.052188	
16	1508	263.3806905	5	31	30	600	0.053928	
17	1648	287.8324787	5	31	27	666.6667	0.05992	
18	1796	313.681512	5	31	26	692.3077	0.062225	
19	1898	331.4963863	5	30.8	25	720	0.064714	
20		0				#DIV/0!	#DIV/0!	
21		0				#DIV/0!	#DIV/0!	
22		0				#DIV/0!	#DIV/0!	
23		0				#DIV/0!	#DIV/0!	
24		0				#DIV/0!	#DIV/0!	
25		0				#DIV/0!	#DIV/0!	

Figure 71: Data for 0.4M H<sub>2</sub>SO<sub>4</sub> Sonicated

H2SO4	0.5M							
Sonicated	Contact Area (cm2)	5.725552611					Production Rate	
Voltage (V)	Applied Current (mA)	Current Density (mA/cm2)	Vol (cm3)	Temp (oC)	Time (s)	cm3/hour	g/hour	
1	0	0				#DIV/0!	#DIV/0!	
2	1	0.17465563				#DIV/0!	#DIV/0!	
3	59	10.30468219				#DIV/0!	#DIV/0!	
4	182	31.78732471	1	28.2	92	39.13043	0.003517	
5	320	55.88980169	1	28.3	35	102.8571	0.009245	
6	464	81.04021245	2	28.7	42	171.4286	0.015408	
7	611	106.7145901	3	29.1	43	251.1628	0.022575	
8	756	132.0396565	4	29.4	47	306.383	0.027538	
9	912	159.2859348	5	29.7	48	375	0.033705	
10	1063	185.658935	5	30.1	40	450	0.040446	
11	1212	211.6826239	5	29.9	35	514.2857	0.046224	
12	1356	236.8330347	5	30.6	32	562.5	0.050558	
13	1453	253.7746308	5	31	28	642.8571	0.05778	
14	1682	293.7707701	5	31.8	26	692.3077	0.062225	
15	1736	303.2021742	5	32.1	23	782.6087	0.070341	
16	1950	340.578479	5	32	21	857.1429	0.07704	
17		0				#DIV/0!	#DIV/0!	
18		0				#DIV/0!	#DIV/0!	
19		0				#DIV/0!	#DIV/0!	
20		0				#DIV/0!	#DIV/0!	
21		0				#DIV/0!	#DIV/0!	
22		0				#DIV/0!	#DIV/0!	
23		0				#DIV/0!	#DIV/0!	
24		0				#DIV/0!	#DIV/0!	
25		0				#DIV/0!	#DIV/0!	

Figure 72: Data for 0.5M H<sub>2</sub>SO<sub>4</sub> Sonicated

H2SO4	1.0M							
Sonicated	Contact Area (cm2)	4.783074815					Production Rate	
Voltage (V)	Applied Current (mA)	Current Density (mA/cm2)	Vol (cm3)	Temp (oC)	Time (s)	cm3/hour	g/hour	
1	0	0				#DIV/0!	#DIV/0!	
2	2	0.418141066				#DIV/0!	#DIV/0!	
3	74	15.47121943				#DIV/0!	#DIV/0!	
4	279	58.33067865	1	29.2	33	109.0909	0.009805	
5	515	107.6713244	2	29.3	38	189.4737	0.01703	
6	768	160.5661692	3	29.8	43	251.1628	0.022575	
7	1023	213.8791551	5	30.4	43	418.6047	0.037624	
8	1305	272.8370453	5	30.9	30	600	0.053928	
9	1570	328.2407365	5	31.2	26	692.3077	0.062225	
10	1817	379.8811581	5	31.3	21	857.1429	0.07704	
11		0				#DIV/0!	#DIV/0!	
12		0				#DIV/0!	#DIV/0!	
13		0				#DIV/0!	#DIV/0!	
14		0				#DIV/0!	#DIV/0!	
15		0				#DIV/0!	#DIV/0!	
16		0				#DIV/0!	#DIV/0!	
17		0				#DIV/0!	#DIV/0!	
18		0				#DIV/0!	#DIV/0!	
19		0				#DIV/0!	#DIV/0!	
20		0				#DIV/0!	#DIV/0!	
21		0				#DIV/0!	#DIV/0!	
22		0				#DIV/0!	#DIV/0!	
23		0				#DIV/0!	#DIV/0!	
24		0				#DIV/0!	#DIV/0!	
25		0				#DIV/0!	#DIV/0!	

Figure 73: Data for 1.0M H<sub>2</sub>SO<sub>4</sub> Sonicated

H2SO4	0.1M		0.2M		0.3M		0.4M		0.5M		1.0M	
Sonicated												
Voltage (V)	V ideal	Efficiency (%)	V ideal	Efficiency (%)	V ideal	Efficiency (%)	V ideal	Efficiency (%)	V ideal	Efficiency (%)	V ideal	Efficiency (%)
1	0	#DIV/0!	0	#DIV/0!	0	#DIV/0!	0	#DIV/0!	0	#DIV/0!	0	#DIV/0!
2	0	#DIV/0!	0	#DIV/0!	0	#DIV/0!	0	#DIV/0!	0	#DIV/0!	0	#DIV/0!
3	0	#DIV/0!	0	#DIV/0!	0	#DIV/0!	0	#DIV/0!	0	#DIV/0!	0	#DIV/0!
4	0	#DIV/0!	0	#DIV/0!	4.635813	21.57118933	2.540242	39.36632707	3.796922	26.33712181	2.507492	39.88047953
5	0	#DIV/0!	2.660383	37.58857184	3.815267	26.21048535	2.452313	40.77782814	2.54059	39.36093557	5.33158	37.51233248
6	3.807301	26.26532315	2.220246	45.04005084	2.603855	38.40459713	3.082376	32.44250213	4.426492	45.18250112	9.011812	33.28964088
7	3.372711	29.64974036	2.655391	37.65923206	2.763607	36.18459154	4.397618	45.47916955	5.975541	50.20465683	12.02779	41.57039639
8	3.266035	30.61816319	2.642672	37.84048716	4.569887	43.76476289	3.990465	50.11947565	8.089433	49.44722276	10.72231	46.63175043
9	3.472197	28.80020975	4.03228	49.59973316	6.556864	45.75357881	6.509588	46.08586736	9.976195	50.11930893	11.19071	44.67989931
10	3.115109	32.10160543	3.252399	61.49306592	5.842781	51.34540967	6.075459	49.37898736	9.702761	51.53172286	10.4641	47.78243654
11	3.021751	33.09339457	3.41272	58.60428822	8.803537	45.43628207	8.023111	49.85596985	9.673558	51.68729154	0	#DIV/0!
12	5.234664	38.20684877	4.987351	60.15217128	8.07561	49.53186348	11.47678	43.56620812	9.918071	50.41302681	0	#DIV/0!
13	5.017978	39.85668997	5.705436	52.58143721	10.81082	46.2499766	9.821329	50.9096059	9.311352	53.69789501	0	#DIV/0!
14	4.863041	41.12653198	5.998613	50.01156112	11.47466	43.57426145	9.605577	52.05309307	10.03527	49.82424778	0	#DIV/0!
15	5.196996	38.48376738	8.951924	44.68313194	10.89258	45.9028282	9.943883	50.28217007	9.171376	54.51744553	0	#DIV/0!
16	5.166409	38.71160517	7.5856	52.73148985	11.4592	43.63305928	10.35408	48.29012291	9.403046	53.17425911	0	#DIV/0!
17	7.650014	39.21561681	9.275104	53.90775108	12.18424	41.03661962	10.1838	49.09756294	0	#DIV/0!	0	#DIV/0!
18	7.460969	40.20925283	8.962999	55.78490091	12.5439	39.86001406	10.68732	46.78441752	0	#DIV/0!	0	#DIV/0!
19	7.207981	41.62053069	8.439517	59.24509592	12.62143	39.61517038	10.85275	46.07128901	0	#DIV/0!	0	#DIV/0!
20	9.283817	43.08572732	8.543032	58.52723103	12.20321	40.9728123	0	#DIV/0!	0	#DIV/0!	0	#DIV/0!
21	9.363266	42.72013671	8.183337	61.09977075	9.77865	51.13180204	0	#DIV/0!	0	#DIV/0!	0	#DIV/0!
22	9.527851	41.98218545	9.060037	55.18741373	9.641194	51.86079676	0	#DIV/0!	0	#DIV/0!	0	#DIV/0!
23	9.788297	40.86512859	9.363072	53.40127622	0	#DIV/0!	0	#DIV/0!	0	#DIV/0!	0	#DIV/0!
24	9.387597	42.60941459	9.492662	52.67226277	0	#DIV/0!	0	#DIV/0!	0	#DIV/0!	0	#DIV/0!
25	8.788992	45.51147638	9.37542	53.33094606	0	#DIV/0!	0	#DIV/0!	0	#DIV/0!	0	#DIV/0!

Figure 74: Data of H<sub>2</sub>SO<sub>4</sub> Efficiency of H<sub>2</sub> production

**Comparison**

NaOH

	0.1M		
Voltage	Enhancement in Current	Enhancement in Output	Enhancement in Efficiency
1	0	#DIV/0!	#DIV/0!
2	0.449907966	#DIV/0!	#DIV/0!
3	2.549478476	#DIV/0!	#DIV/0!
4	1.799631865	#DIV/0!	#DIV/0!
5	0.899815933	#DIV/0!	#DIV/0!
6	0.899815933	#DIV/0!	#DIV/0!
7	1.799631865	-0.018555763	-3.915144055
8	1.499693221	-0.854839255	-4.076830687
9	1.499693221	2.615298088	0.286682159
10	1.499693221	-5.606678777	-8.136685723
11	1.049785255	-15.02489185	-14.6865578
12	0.599877288	-5.632333768	-5.246774107
13	0.749846611	-17.24392041	-13.21925083
14	-0.149969322	-15.79640193	-9.784863477
15	-0.149969322	0	0.252164095
16	-0.299938644	2.307692308	1.51453036
17	0.599877288	11.14551084	4.912665078
18	0.449907966	0	-0.438994898
19	0.899815933	0	-0.819905452
20	0.749846611	-51.28205128	-21.62708528
21	-0.149969322	-24.1509434	-9.05328779
22	0	-19.63636364	-7.0447274
23	-0.299938644	-36.28219485	-12.36416636
24	-0.299938644	-11.62227603	-3.516560578
25	-1.649662543	-52.13705404	-14.89011767

**Figure 75: Data for 0.1M NaOH Ultrasound Enhancement**

	0.2M		
Voltage	Enhancement in Current	Enhancement in Output	Enhancement in Efficiency
1	0	#DIV/0!	#DIV/0!
2	0.895383342	#DIV/0!	#DIV/0!
3	3.18186143	#DIV/0!	#DIV/0!
4	6.027584725	#DIV/0!	#DIV/0!
5	8.273430731	13.0952381	1.666039833
6	10.78744848	10.83333333	-2.683556469
7	13.45143555	-5.704225352	-18.01479131
8	16.71529991	-15.15151515	-27.36507513
9	18.72030848	-14.28571429	-25.50773578
10	23.06129241	-10.24667932	-25.2920519
11	26.92060147	6.315789474	-18.48107347
12	30.53907309	18.36734694	-14.67832865
13	32.7849191	38.0952381	-8.886363501
14	38.34412673	28.57142857	-15.56021654
15	37.99025823	24.3902439	-14.15924174
16	40.98151825	35.52631579	-12.33725965
17	43.91367707	45.40540541	-10.20934388
18	46.81406898	15.82417582	-14.97754468
19	47.89192731	30.85714286	-15.21678541
20	54.07834654	46.37681159	-13.58445451
21	55.06976935	54.85714286	-12.70869119
22	59.4609893	29.8136646	-16.91760302
23	58.68897974	61.91646192	-12.14348309
24	60.00324291	-57.34196117	-25.96335876
25	62.46259204	-16.30434783	-22.68886596

Figure 76: Data for 0.2M NaOH Ultrasound Enhancement



	0.3M		
Voltage	Enhancement in Current	Enhancement in Output	Enhancement in Efficiency
1	0	#DIV/0!	#DIV/0!
2	0.782558124	#DIV/0!	#DIV/0!
3	2.694614947	#DIV/0!	#DIV/0!
4	4.642919293	#DIV/0!	#DIV/0!
5	6.274705093	#DIV/0!	#DIV/0!
6	7.852766885	-20.21390374	-23.26816513
7	9.562225947	-28.84615385	-25.39994946
8	10.61469866	-70.1754386	-43.28231509
9	13.4769584	-76.35054022	-40.94641423
10	16.13014761	-81.52173913	-38.46091375
11	18.18007447	-121.7391304	-48.01240594
12	21.03650872	-67.76470588	-31.01419007
13	24.53180555	-67.66917293	-32.32170515
14	25.36938224	-66.66666667	-28.56452881
15	26.49952821	-76.23529412	-28.49536175
16	29.06921866	-65.2173913	-25.17658718
17	31.48356259	-85.71428571	-28.54180797
18	31.80137569	-102.0242915	-29.68732171
19	35.15944976	-115.7894737	-31.02567703
20	36.49284077	-143.6170213	-33.82448887
21	38.04695331	-160	-34.9687381
22	39.51756708	-154.2857143	-33.37080746
23	41.5377192	-140	-30.87642458
24	45.21231181	-144.8916409	-31.38513218
25	45.72754446	-181.3953488	-33.32348693

Figure 77: Data for 0.3M NaOH Ultrasound Enhancement

	0.4M		
Voltage	Enhancement in Current	Enhancement in Output	Enhancement in Efficiency
1	0	#DIV/0!	#DIV/0!
2	0.698622521	#DIV/0!	#DIV/0!
3	1.986013492	#DIV/0!	#DIV/0!
4	2.569227522	#DIV/0!	#DIV/0!
5	2.926561833	-4.090909091	-7.712041729
6	3.308582452	-32.77310924	-23.99623925
7	3.415350735	-21.71945701	-13.227196
8	3.647402032	5.882352941	-0.434024117
9	3.704797698	-53.68421053	-20.63608479
10	4.910723852	-61.76470588	-21.09951453
11	5.042178443	-28.70813397	-10.324468
12	5.923479645	-28.23529412	-9.63105003
13	6.804780846	-2.470830474	-3.727589019
14	6.311671841	-36.58536585	-9.785660804
15	6.767751384	-25.21008403	-7.43162091
16	6.82514705	-53.61702128	-11.19753729
17	5.608729215	-44.06364749	-8.617567427
18	7.387994877	-44.58204334	-8.819712578
19	7.494763159	-34.34022258	-7.012177487
20	8.448271812	-21.42857143	-5.336111394
21	6.284516902	-90	-12.3003129
22	5.164992826	-94.73684211	-11.7993859
23	6.893034398	-126.0869565	-14.79034699
24	3.282661828	-152.3809524	-15.86191475
25	-0.509772264	-162.8959276	-15.09512084

Figure 78: Data for 0.4M NaOH Ultrasound Enhancement

	0.5M		
Voltage	Enhancement in Current	Enhancement in Output	Enhancement in Efficiency
1	0	#DIV/0!	#DIV/0!
2	1.047933782	#DIV/0!	#DIV/0!
3	-7.689784994	#DIV/0!	#DIV/0!
4	2.742648837	-14.09601634	-13.09105195
5	-7.684847732	-24.61538462	-6.53204861
6	-8.906819987	-44.85049834	-11.44263743
7	-7.907641663	-51.42857143	-11.4680101
8	-9.380179946	-84.7826087	-17.25703172
9	-10.17878201	-61.68910649	-9.093568136
10	-10.22753747	-56.51491366	-6.965114762
11	-9.55113263	-116.3666121	-17.20056495
12	-7.4299616	-84.9213691	-10.9221323
13	-8.503816006	17.54385965	4.847823813
14	-6.056168551	7.653061224	2.428539414
15	-7.803959169	58.60465116	8.85544196
16	-1.255915928	17.14285714	1.948242016
17	-8.681557425	-156.3706564	-14.29249307
18	-9.706039213	-70.58823529	-4.968147546
19	-10.12694077	-97.4025974	-6.891969096
20	-13.46391247	23.80952381	5.102976896
21	-7.426258654	-80	-5.012616794
22	-6.478304421	-54.60060667	-2.962052927
23	-292.4401781	#DIV/0!	#DIV/0!
24	-304.1377852	#DIV/0!	#DIV/0!
25	0	#DIV/0!	#DIV/0!

Figure 79: Data for 0.5M NaOH Ultrasound Enhancement

	1.0M		
Voltage	Enhancement in Current	Enhancement in Output	Enhancement in Efficiency
1	0	#DIV/0!	#DIV/0!
2	1.047933782	#DIV/0!	#DIV/0!
3	6.844278939	#DIV/0!	#DIV/0!
4	11.78092341	26.32411067	4.604616694
5	22.33864026	48.20450396	2.64995109
6	27.67211714	60.90225564	-1.198884875
7	31.72992904	14.2999007	-13.69238177
8	37.88545999	60.92843327	-6.84360856
9	40.12265666	58.64661654	-6.591431992
10	46.69970632	77.5862069	-7.10170606
11	50.75751822	100	-4.225106258
12	48.82581461	112.5	-2.071364918
13	54.38331973	54.54545455	-9.652561541
14	47.28045172	-99.31034483	-22.08295039
15	50.83898304	57.69230769	-7.780633928
16	59.78344964	68.18181818	-8.091303027
17	44.67296042	19.93355482	-8.347644088
18	-299.9386442	#DIV/0!	#DIV/0!
19	0	#DIV/0!	#DIV/0!
20	0	#DIV/0!	#DIV/0!
21	0	#DIV/0!	#DIV/0!
22	0	#DIV/0!	#DIV/0!
23	0	#DIV/0!	#DIV/0!
24	0	#DIV/0!	#DIV/0!
25	0	#DIV/0!	#DIV/0!

Figure 80: Data for 1.0M NaOH Ultrasound Enhancement

NaCl

	0.1M		
Voltage	Enhancement in Current	Enhancement in Output	Enhancement in Efficiency
1	0	#DIV/0!	#DIV/0!
2	0	#DIV/0!	#DIV/0!
3	-0.149969322	#DIV/0!	#DIV/0!
4	-0.449907966	#DIV/0!	#DIV/0!
5	-1.349723899	#DIV/0!	#DIV/0!
6	-2.249539832	#DIV/0!	#DIV/0!
7	-3.149355764	#DIV/0!	#DIV/0!
8	-2.699447798	#DIV/0!	#DIV/0!
9	-1.499693221	#DIV/0!	#DIV/0!
10	-1.649662543	#DIV/0!	#DIV/0!
11	-1.499693221	#DIV/0!	#DIV/0!
12	-0.749846611	#DIV/0!	#DIV/0!
13	-1.049785255	#DIV/0!	#DIV/0!
14	-0.299938644	#DIV/0!	#DIV/0!
15	0	#DIV/0!	#DIV/0!
16	0.299938644	-4.06504065	-7.388930878
17	-0.599877288	-7.272027703	-8.459561689
18	-0.299938644	-6.037735849	-7.200727276
19	0.749846611	-11.20238984	-14.06356678
20	0.149969322	-14.2791762	-15.15333111
21	-1.199754577	-10.25478715	-8.314487905
22	-0.749846611	-11.35135135	-9.614118959
23	-0.599877288	-15.45454545	-12.63640734
24	-1.049785255	-14.19318502	-10.51374149
25	-2.399509154	-12.98360656	-7.120304538

Figure 81: Data for 0.1M NaCl Ultrasound Enhancement

	0.2M		
Voltage	Enhancement in Current	Enhancement in Output	Enhancement in Efficiency
1	0	#DIV/0!	#DIV/0!
2	0.149969322	#DIV/0!	#DIV/0!
3	0.299938644	#DIV/0!	#DIV/0!
4	0.599877288	#DIV/0!	#DIV/0!
5	1.049785255	#DIV/0!	#DIV/0!
6	1.499693221	#DIV/0!	#DIV/0!
7	1.799631865	#DIV/0!	#DIV/0!
8	2.249539832	#DIV/0!	#DIV/0!
9	2.699447798	#DIV/0!	#DIV/0!
10	3.299325086	1.787576344	-4.713313296
11	3.449294409	-6.98757764	-15.19493415
12	3.449294409	-2.5	-8.655426285
13	2.84941712	-5.555555556	-10.12082264
14	2.399509154	-7.142857143	-10.12736051
15	3.599263731	-4.597701149	-9.320287252
16	2.09957051	-3.126356926	-6.159919556
17	3.299325086	1.902748414	-4.697934543
18	1.199754577	1.993355482	-1.861127192
19	3.149355764	-21.28603104	-15.70050273
20	1.499693221	-34.13793103	-18.93325334
21	2.549478476	0	-4.477100223
22	3.299325086	-7.552447552	-8.789124303
23	0.299938644	-14.1509434	-7.7520159
24	2.84941712	-9.58296362	-8.271550095
25	4.049171697	-13.63636364	-10.92565683

Figure 82: Data for 0.2M NaCl Ultrasound Enhancement

	0.3M		
Voltage	Enhancement in Current	Enhancement in Output	Enhancement in Efficiency
1	0	#DIV/0!	#DIV/0!
2	0.059101211	#DIV/0!	#DIV/0!
3	1.072686974	#DIV/0!	#DIV/0!
4	2.554649832	#DIV/0!	#DIV/0!
5	4.332118743	#DIV/0!	#DIV/0!
6	6.318658187	#DIV/0!	#DIV/0!
7	8.155228309	#DIV/0!	#DIV/0!
8	10.01913274	0.491803279	-13.70863716
9	11.70573354	-10.10526316	-25.0959446
10	13.77870851	-6.6359447	-22.31158317
11	15.31090739	-11.84210526	-25.00601266
12	17.86555722	-28.02197802	-33.93078794
13	20.29757204	-16.47597254	-26.76000311
14	22.40231391	-17.2972973	-25.22012049
15	23.54370604	-11.01591187	-19.35622462
16	26.934638	15.2027027	-11.83265295
17	29.63925716	-27.87096774	-29.93935589
18	30.50804496	-18.06020067	-25.34129392
19	34.73082646	-10	-22.99942088
20	33.94034777	3.986710963	-19.01771776
21	36.52233191	0	-20.89723295
22	39.19518416	0	-21.27228415
23	40.06840455	-6.050420168	-22.06560339
24	41.54150223	6.818181818	-19.0005978
25	45.22794024	15	-17.90972194

Figure 83: Data for 0.3M NaCl Ultrasound Enhancement

	0.4M		
Voltage	Enhancement in Current	Enhancement in Output	Enhancement in Efficiency
1	-0.349311261	#DIV/0!	#DIV/0!
2	-0.698622521	#DIV/0!	#DIV/0!
3	-1.397245042	#DIV/0!	#DIV/0!
4	0	#DIV/0!	#DIV/0!
5	1.047933782	#DIV/0!	#DIV/0!
6	1.746556303	#DIV/0!	#DIV/0!
7	2.445178824	-0.767386091	-4.398936023
8	4.366390757	2.395740905	-3.703662033
9	4.017079496	8.975834292	0.806604861
10	6.28760269	6.302521008	-3.485085972
11	6.46225832	-6.818181818	-9.359156907
12	6.636913951	8.586762075	-2.397444782
13	6.986225211	36.26373626	6.795132857
14	10.82864908	7.552447552	-6.8053101
15	11.70192723	21.53846154	-2.730168387
16	9.082092775	40.61538462	4.03977126
17	12.05123849	36.28219485	1.260281106
18	14.14710605	18.9848385	-4.207383094
19	13.97245042	21.0989011	-3.262166935
20	15.71900673	36.51115619	-1.558449956
21	14.14710605	18.90472618	-4.223691604
22	15.89366236	23.41463415	-3.944084547
23	19.91074185	77.64705882	3.599513254
24	23.0545432	32	-6.065109786
25	22.18126505	42.85714286	-3.840074283

Figure 84: Data for 0.4M NaCl Ultrasound Enhancement



	0.5M		
Voltage	Enhancement in Current	Enhancement in Output	Enhancement in Efficiency
1	0	#DIV/0!	#DIV/0!
2	0.230670303	#DIV/0!	#DIV/0!
3	1.124433662	#DIV/0!	#DIV/0!
4	2.184979047	#DIV/0!	#DIV/0!
5	3.447276884	#DIV/0!	#DIV/0!
6	5.240183668	#DIV/0!	#DIV/0!
7	7.413730076	#DIV/0!	#DIV/0!
8	6.766777216	-31.16883117	-29.49172035
9	8.461497806	-35.40372671	-28.25205031
10	8.685443027	-38.57634902	-25.83551049
11	12.30084695	-21.4084507	-18.93142315
12	13.64384577	-51.69230769	-30.75478336
13	12.16029275	-37.5	-21.016666
14	15.62572735	-28.980322	-19.42109358
15	16.91089047	-27.15273413	-18.90005079
16	16.42533957	-9.979209979	-12.62702551
17	19.14092756	-23.58722359	-16.29137811
18	21.46982336	-32.14285714	-18.66048313
19	21.45166564	-27.06766917	-17.4323837
20	22.62720992	-7.287449393	-13.04454359
21	25.83305637	-8.571428571	-14.2539865
22	26.85863133	-18.7012987	-15.56132058
23	28.9629094	-17.5	-15.19527621
24	31.32072304	-88.11188811	-26.33024751
25	38.70217273	-8.780487805	-15.34014236

Figure 85: Data for 0.5M NaCl Ultrasound Enhancement

	1.0M		
Voltage	Enhancement in Current	Enhancement in Output	Enhancement in Efficiency
1	0.149969322	#DIV/0!	#DIV/0!
2	0.618449341	#DIV/0!	#DIV/0!
3	1.835383066	#DIV/0!	#DIV/0!
4	3.063924324	#DIV/0!	#DIV/0!
5	5.415146142	-2.166586423	-13.6758473
6	5.888269173	-9.77443609	-16.64880158
7	6.905553337	3.260869565	-7.127633822
8	11.63910516	-32.03389831	-27.32028044
9	9.034374829	-81.81818182	-37.32905586
10	13.0737962	-4.615384615	-14.27148227
11	15.64648974	9	-11.18420129
12	19.62740914	0	-15.99409528
13	22.48425509	-9.538950715	-17.91566218
14	24.23420671	28.50678733	-11.04086251
15	28.26944937	14.28571429	-15.93570362
16	31.78188876	28.57142857	-13.90702094
17	34.37454725	71.1018711	-8.070544883
18	35.44894048	44.72049689	-12.18960638
19	37.32889647	31.16883117	-14.27301979
20	40.05295224	97.98387097	-4.819715103
21	45.53217196	124.137931	-3.740451785
22	48.6731703	109.5238095	-6.448417348
23	51.45572803	128.5714286	-4.077841728
24	54.06556568	133.3333333	-3.834428896
25	52.33047169	92.30769231	-7.91696265

Figure 86: Data for 1.0M NaCl Ultrasound Enhancement

H2SO4

	0.1M		
Voltage	Enhancement in Current	Enhancement in Output	Enhancement in Efficiency
1	0	#DIV/0!	#DIV/0!
2	0.268171743	#DIV/0!	#DIV/0!
3	2.409113101	#DIV/0!	#DIV/0!
4	5.58654194	#DIV/0!	#DIV/0!
5	8.582234557	#DIV/0!	#DIV/0!
6	11.87786582	15.56776557	1.318932683
7	14.69182221	19.93499458	-0.435764272
8	18.25562522	22.42524917	-2.953863864
9	21.57859079	7.714285714	-14.28501746
10	26.09687834	18.14109742	-12.16754696
11	28.01545139	23.37662338	-10.14407725
12	31.33841697	43.87917329	-5.47159676
13	35.02042239	47.50733138	-7.240138305
14	37.2662684	34.61538462	-13.77951397
15	41.21644557	32.95194508	-14.09122904
16	44.48030993	42.07792208	-12.18169945
17	46.12184605	35.52631579	-14.02936766
18	49.65831475	39.74025974	-14.57972266
19	52.8630779	45	-14.82944625
20	56.74972126	51.72413793	-15.01722238
21	62.39979701	43.07692308	-18.1925799
22	64.26370144	57.27272727	-14.9514102
23	66.59598296	26.31229236	-20.31589404
24	71.05073672	41.95804196	-18.86434021
25	72.91020856	134.5054945	-4.214753914

Figure 87: Data for 0.1M H<sub>2</sub>SO<sub>4</sub> Ultrasound Enhancement

	0.2M		
Voltage	Enhancement in Current	Enhancement in Output	Enhancement in Efficiency
1	0	#DIV/0!	#DIV/0!
2	-0.024686308	#DIV/0!	#DIV/0!
3	0.882535517	#DIV/0!	#DIV/0!
4	0.648632747	#DIV/0!	#DIV/0!
5	-0.631352331	8.067226891	7.782314671
6	-1.936023718	1.411764706	3.037229842
7	-3.789348304	3.260869565	4.228804987
8	-4.993422984	-7.05052879	0.440568742
9	-5.922245329	12.01501877	7.392020354
10	-8.225477881	38.18181818	15.43026452
11	-8.030456047	15	7.905570688
12	-14.9561998	23.41463415	12.54897415
13	-10.7860652	6.585365854	5.513069425
14	-11.61429083	-15.78947368	1.36940532
15	-12.19380192	-31.64835165	-1.331637345
16	-15.07037398	23.94678492	7.958596441
17	-15.87206184	5.590062112	5.215500367
18	-20.94694964	17.14285714	7.708459409
19	-19.50465208	62.95707472	12.30523448
20	-21.70358498	64.28571429	12.1351329
21	-23.18476347	97.98387097	15.51164736
22	-23.36003626	-30.54545455	2.060956249
23	-22.13806401	-37.5	0.905245119
24	-23.71798773	-45.44179523	0.286848031
25	-22.74843298	-71.61803714	-2.170593081

Figure 88: Data for 0.2M H<sub>2</sub>SO<sub>4</sub> Ultrasound Enhancement

	0.3M		
Voltage	Enhancement in Current	Enhancement in Output	Enhancement in Efficiency
1	0	#DIV/0!	#DIV/0!
2	0.049372616	#DIV/0!	#DIV/0!
3	1.460195128	#DIV/0!	#DIV/0!
4	6.778243065	-19.28571429	-29.4129962
5	3.857235651	-17.00404858	-13.50824021
6	3.952895095	-22.7027027	-12.42830001
7	5.272995424	-47.44186047	-18.14105223
8	4.392928538	-45	-13.59244582
9	4.712616229	-45	-11.6036299
10	5.83337462	-42.99182904	-10.42018014
11	7.199144619	-60	-12.11361603
12	12.43387627	-44.58204334	-10.56877856
13	12.92821959	-108.6956522	-17.59426288
14	15.56780309	-120.3208556	-17.7703468
15	10.81877455	-138.4615385	-17.170391
16	7.06460424	-161.6099071	-16.9898477
17	13.17631698	-205.8212058	-20.92631625
18	7.05102677	-250	-21.81440392
19	9.494971279	-288.7700535	-24.03612886
20	20.29584826	-257.1428571	-22.10040691
21	325.7327505	#DIV/0!	#DIV/0!
22	335.862777	#DIV/0!	#DIV/0!
23	0	#DIV/0!	#DIV/0!
24	0	#DIV/0!	#DIV/0!
25	0	#DIV/0!	#DIV/0!

Figure 89: Data for 0.3M H<sub>2</sub>SO<sub>4</sub> Ultrasound Enhancement

	0.4M		
Voltage	Enhancement in Current	Enhancement in Output	Enhancement in Efficiency
1	0	#DIV/0!	#DIV/0!
2	0.224028247	#DIV/0!	#DIV/0!
3	0.934376764	#DIV/0!	#DIV/0!
4	0.705411256	2.780352178	1.379736035
5	0.522115418	-7.418310274	-4.086474797
6	-2.78214693	-64.21404682	-20.1324943
7	-1.820615227	-54.17747794	-12.78626903
8	-3.230203424	-51.89189189	-9.069781498
9	-5.089699586	-105.8161351	-16.07192051
10	-7.598445654	-72.72727273	-8.067982244
11	-10.08435689	-166.507177	-17.97221488
12	-15.06481956	-240	-22.32104702
13	-12.95660884	-180.1801802	-15.08933976
14	-17.69020843	-174.5454545	-12.02678101
15	-15.9294575	-201.9635344	-13.96272206
16	-30.40921156	-218.1818182	-11.3322018
17	287.8324787	#DIV/0!	#DIV/0!
18	313.681512	#DIV/0!	#DIV/0!
19	331.4963863	#DIV/0!	#DIV/0!
20	0	#DIV/0!	#DIV/0!
21	0	#DIV/0!	#DIV/0!
22	0	#DIV/0!	#DIV/0!
23	0	#DIV/0!	#DIV/0!
24	0	#DIV/0!	#DIV/0!
25	0	#DIV/0!	#DIV/0!

Figure 90: Data for 0.4M H<sub>2</sub>SO<sub>4</sub> Ultrasound Enhancement

	0.5M		
Voltage	Enhancement in Current	Enhancement in Output	Enhancement in Efficiency
1	0	#DIV/0!	#DIV/0!
2	-0.17465563	#DIV/0!	#DIV/0!
3	1.222589412	#DIV/0!	#DIV/0!
4	2.095867563	-1.778656126	-3.160313847
5	1.921211933	-21.28078818	-9.883751119
6	0.349311261	2.678571429	0.409607712
7	-3.143801345	21.37555666	5.424190972
8	-6.46225832	-13.61702128	-0.016881199
9	-8.034158993	-34.09090909	-2.224783567
10	-14.84572857	-36.48648649	-0.413097444
11	-31.43801345	-31.16883117	3.655068723
12	-17.46556303	-37.5	-0.099981135
13	-30.91404656	-49.45054945	1.635408288
14	-19.91074185	-57.69230769	-1.36376695
15	-40.86941749	0	5.821612669
16	340.578479	#DIV/0!	#DIV/0!
17	0	#DIV/0!	#DIV/0!
18	0	#DIV/0!	#DIV/0!
19	0	#DIV/0!	#DIV/0!
20	0	#DIV/0!	#DIV/0!
21	0	#DIV/0!	#DIV/0!
22	0	#DIV/0!	#DIV/0!
23	0	#DIV/0!	#DIV/0!
24	0	#DIV/0!	#DIV/0!
25	0	#DIV/0!	#DIV/0!

Figure 91: Data for 0.5M H<sub>2</sub>SO<sub>4</sub> Ultrasound Enhancement

	1.0M		
Voltage	Enhancement in Current	Enhancement in Output	Enhancement in Efficiency
1	0	#DIV/0!	#DIV/0!
2	-0.804448346	#DIV/0!	#DIV/0!
3	0.450835223	#DIV/0!	#DIV/0!
4	8.728479651	3.20855615	-5.518270322
5	11.43607211	-30.93447905	-11.19728587
6	10.01301589	-121.2510024	-19.31900724
7	11.45327956	-110.8071135	-14.05188557
8	14.87067938	-42.85714286	-6.36785405
9	15.78181392	-90.30100334	-8.588908698
10	379.8811581	#DIV/0!	#DIV/0!
11	0	#DIV/0!	#DIV/0!
12	0	#DIV/0!	#DIV/0!
13	0	#DIV/0!	#DIV/0!
14	0	#DIV/0!	#DIV/0!
15	0	#DIV/0!	#DIV/0!
16	0	#DIV/0!	#DIV/0!
17	0	#DIV/0!	#DIV/0!
18	0	#DIV/0!	#DIV/0!
19	0	#DIV/0!	#DIV/0!
20	0	#DIV/0!	#DIV/0!
21	0	#DIV/0!	#DIV/0!
22	0	#DIV/0!	#DIV/0!
23	0	#DIV/0!	#DIV/0!
24	0	#DIV/0!	#DIV/0!
25	0	#DIV/0!	#DIV/0!

Figure 92: Data for 1.0M H<sub>2</sub>SO<sub>4</sub> Ultrasound Enhancement



## 7.2 Appendix II - Graphs

### 7.2.1 Preliminary Experiments

*Silent*

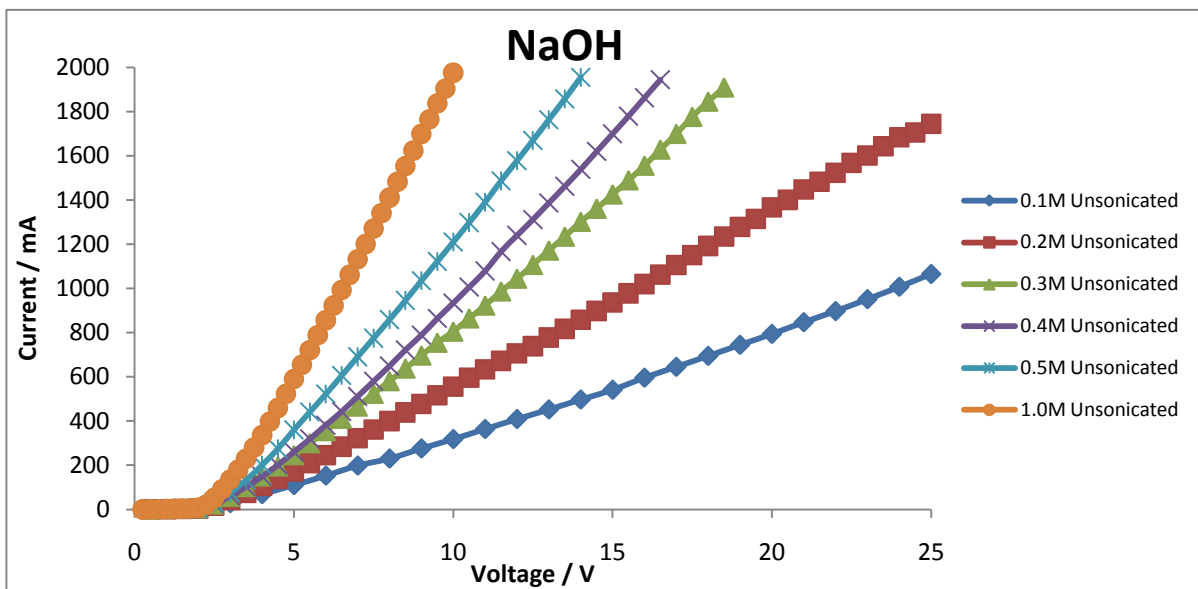

Figure 93: Current Voltage Graph for Silent NaOH solution

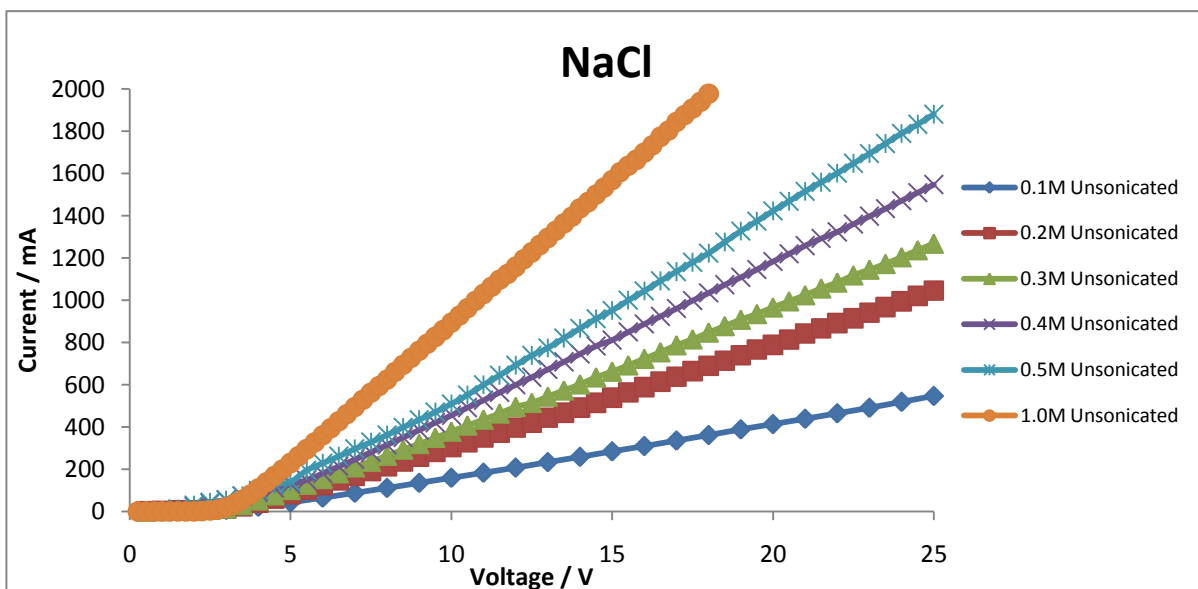

Figure 94: Current Voltage Graph for Silent NaCl solution

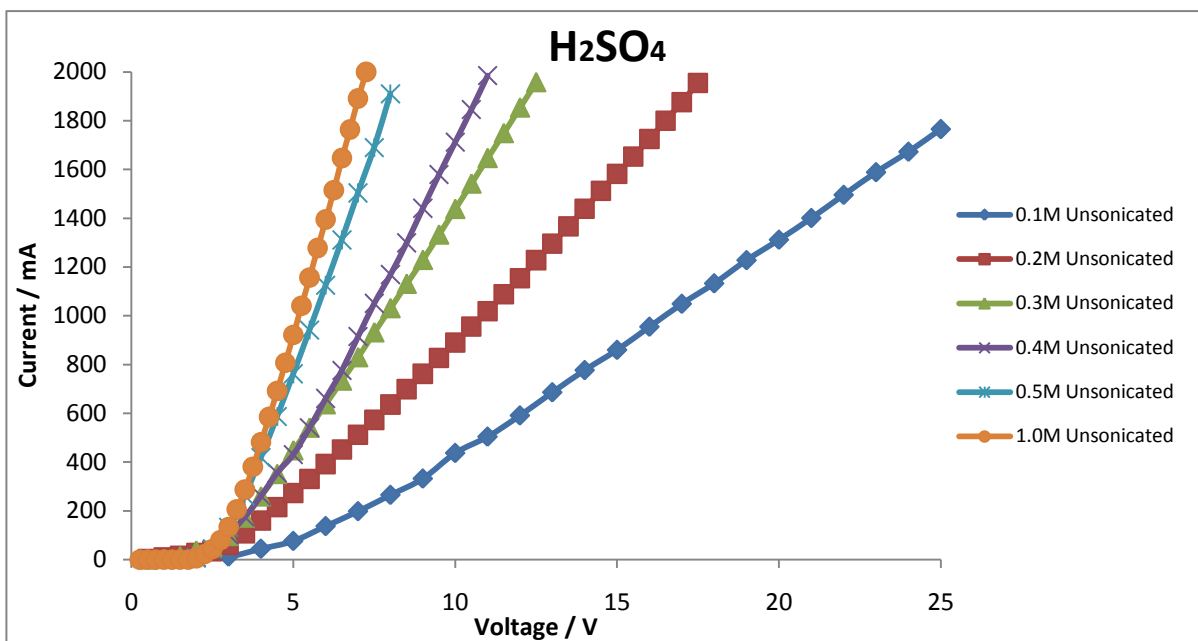

Figure 95: Current Voltage Graph for Silent H<sub>2</sub>SO<sub>4</sub> solution

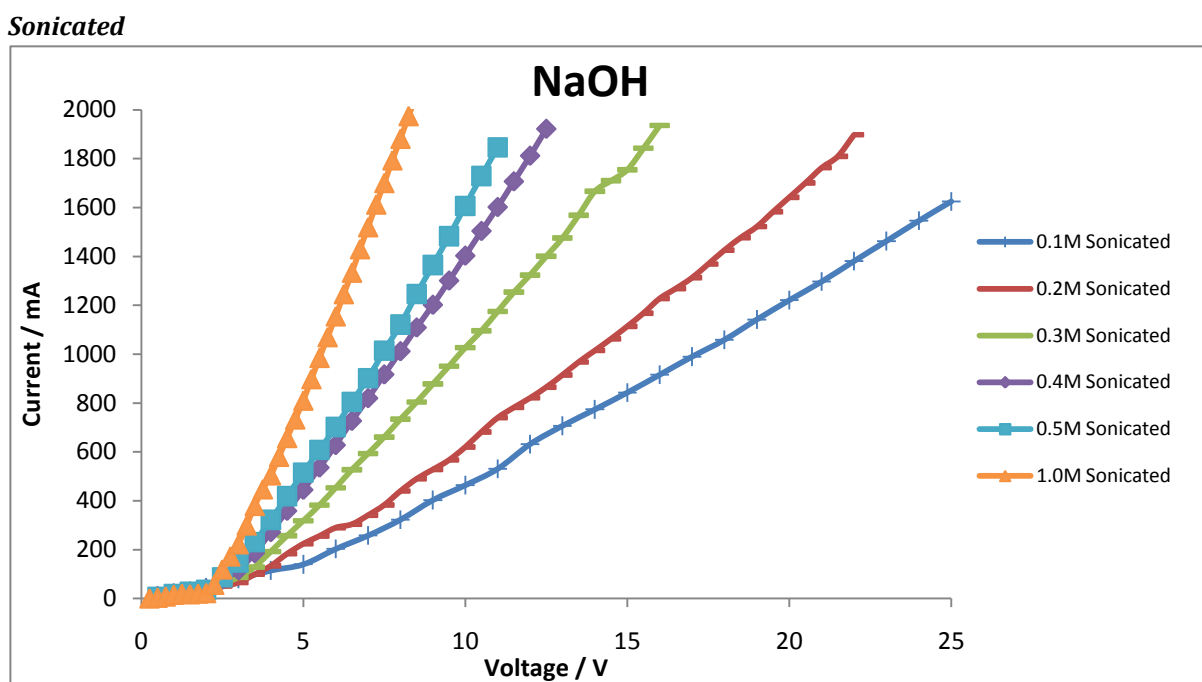

Figure 96: Current Voltage Graph for Sonicated NaOH solution

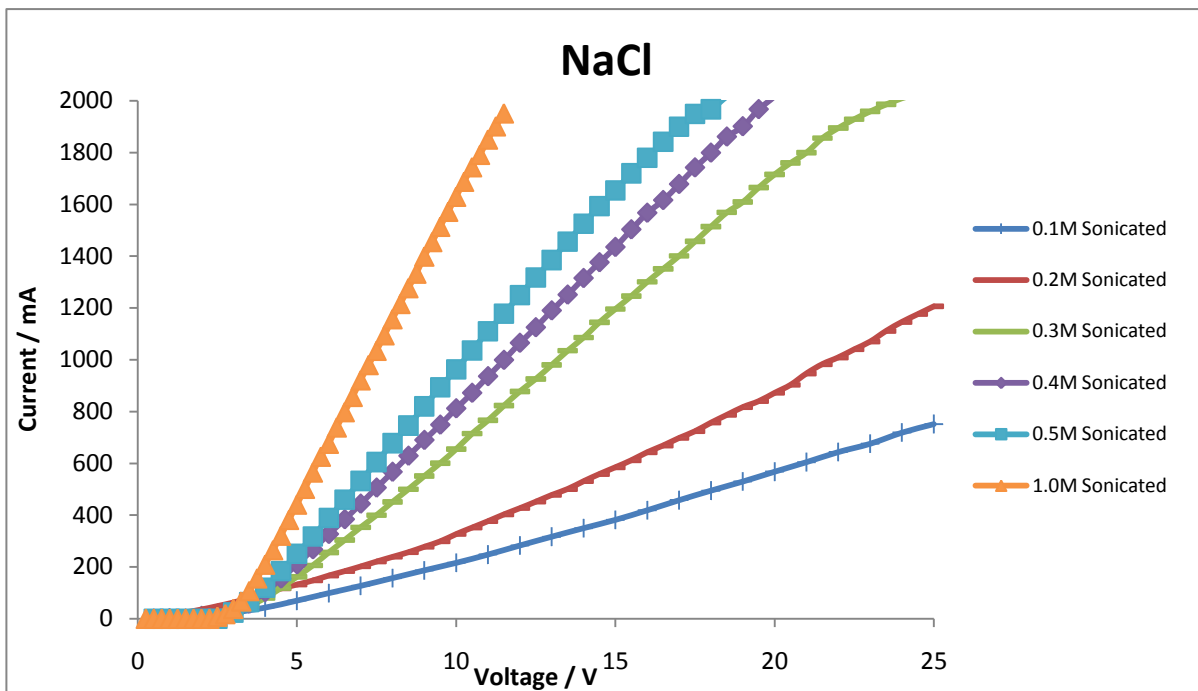

Figure 97: Current Voltage Graph for Sonicated NaCl solution

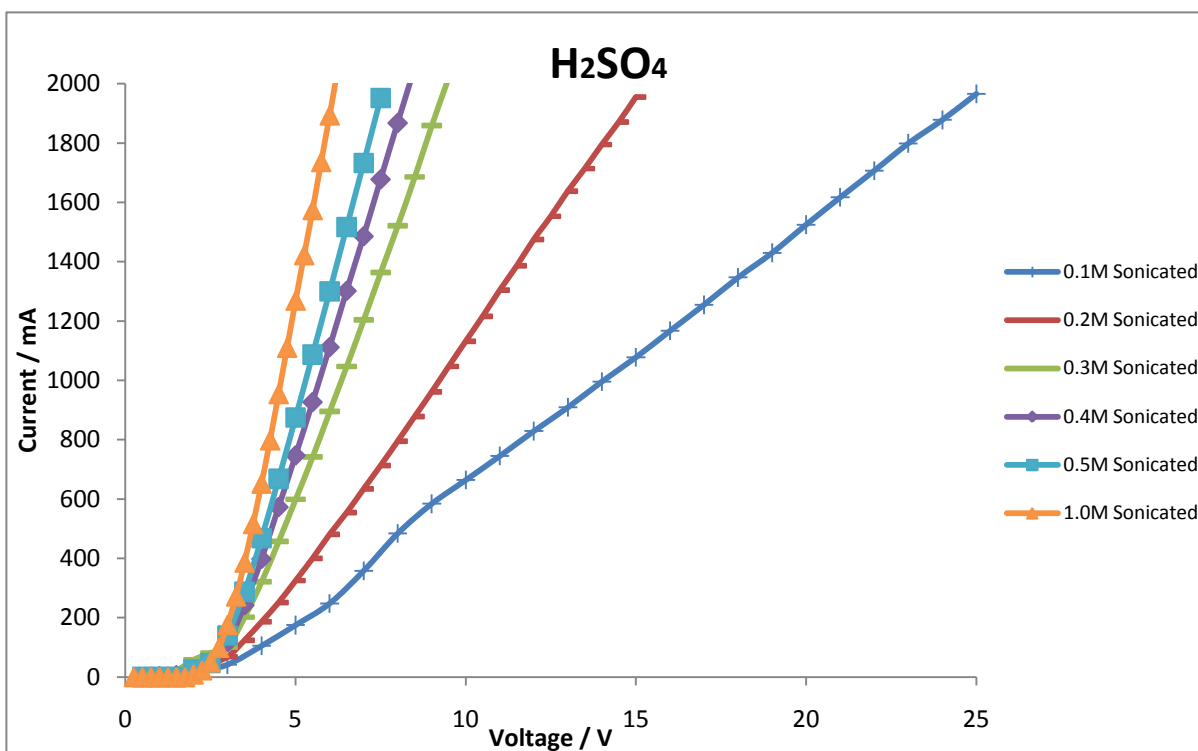

Figure 98: Current Voltage Graph for Sonicated H<sub>2</sub>SO<sub>4</sub> solution

## 7.2.2 Custom Glassware Experiments

*Silent*

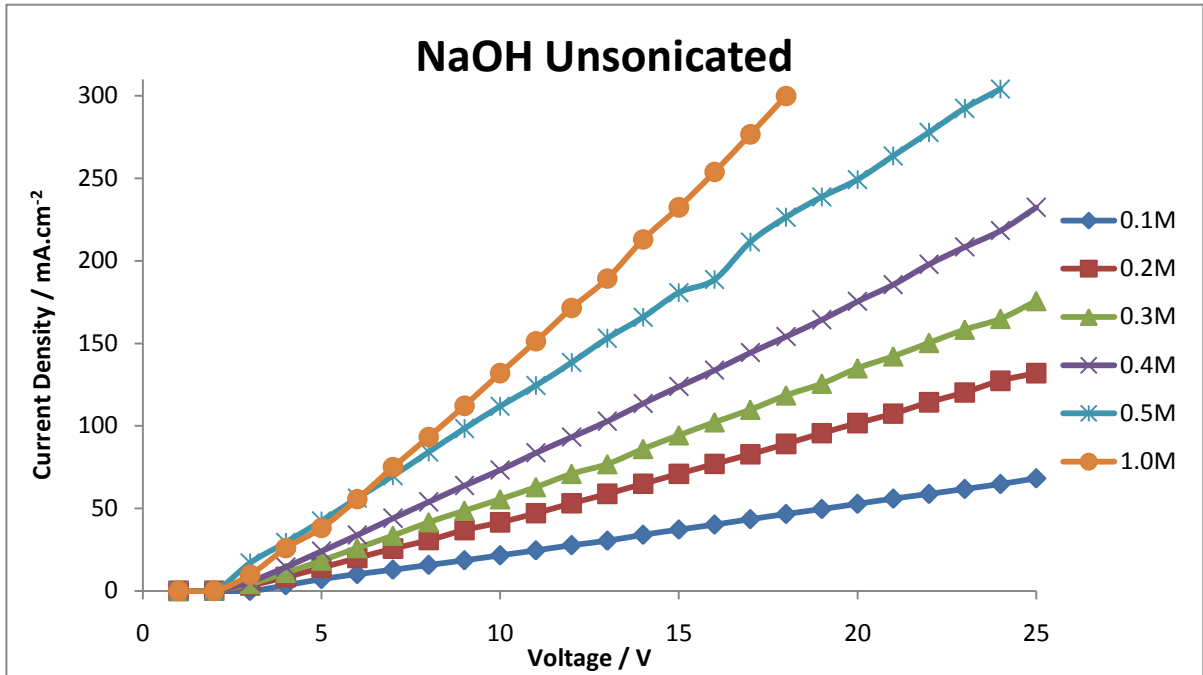

Figure 99: Current Voltage Graph for Silent NaOH solution

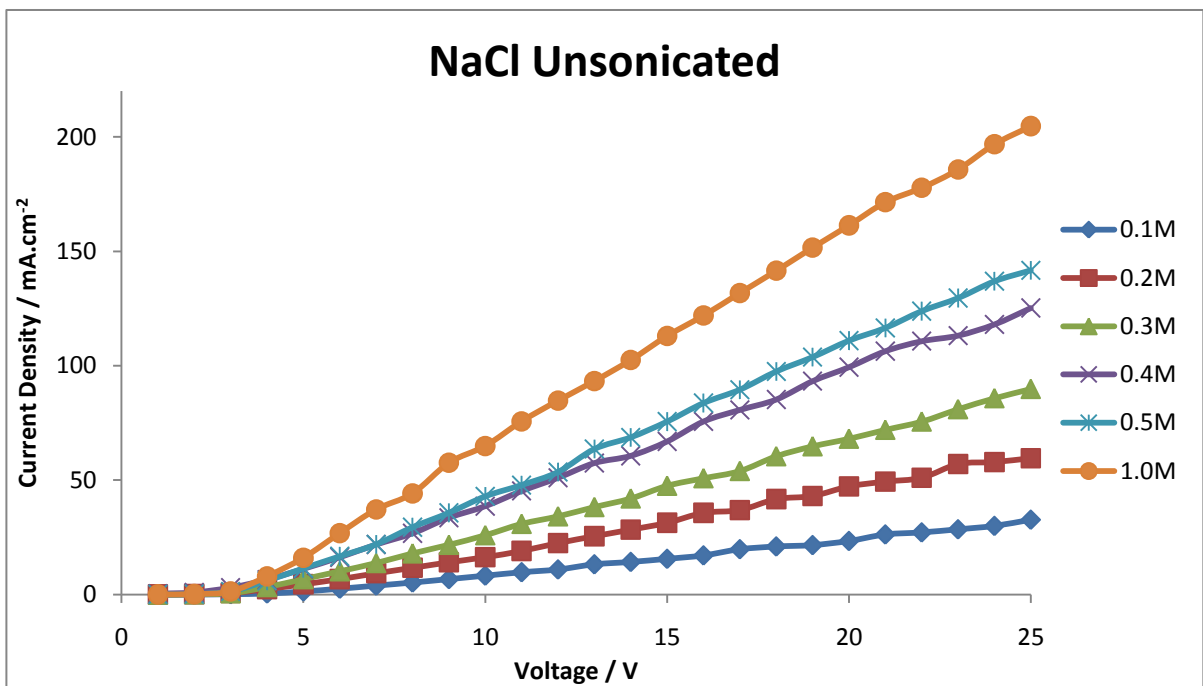
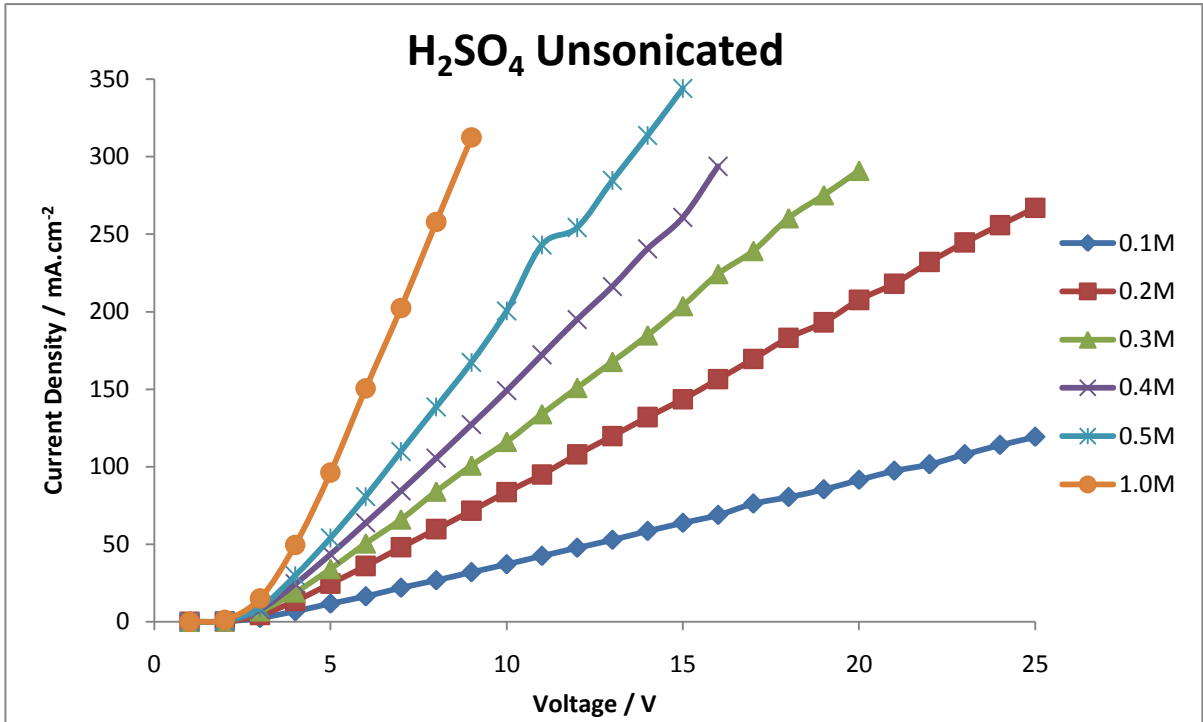

Figure 100: Current Voltage Graph for Silent NaCl solution



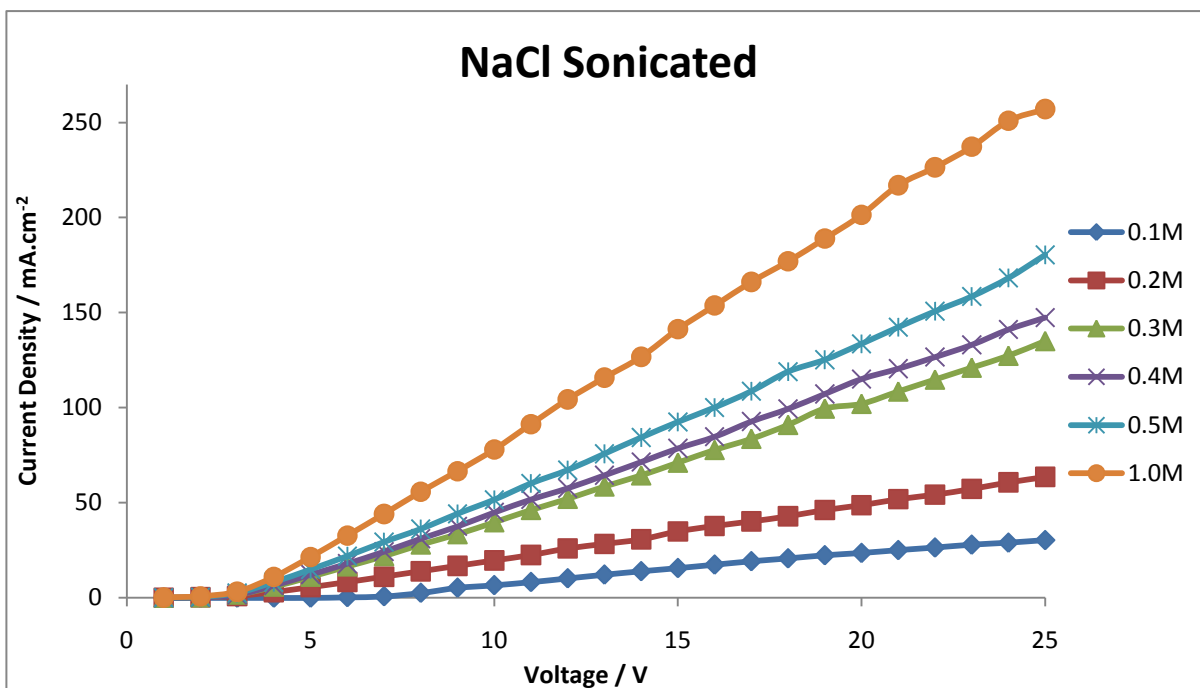

Figure 103: Current Voltage Graph for Sonicated NaCl solution

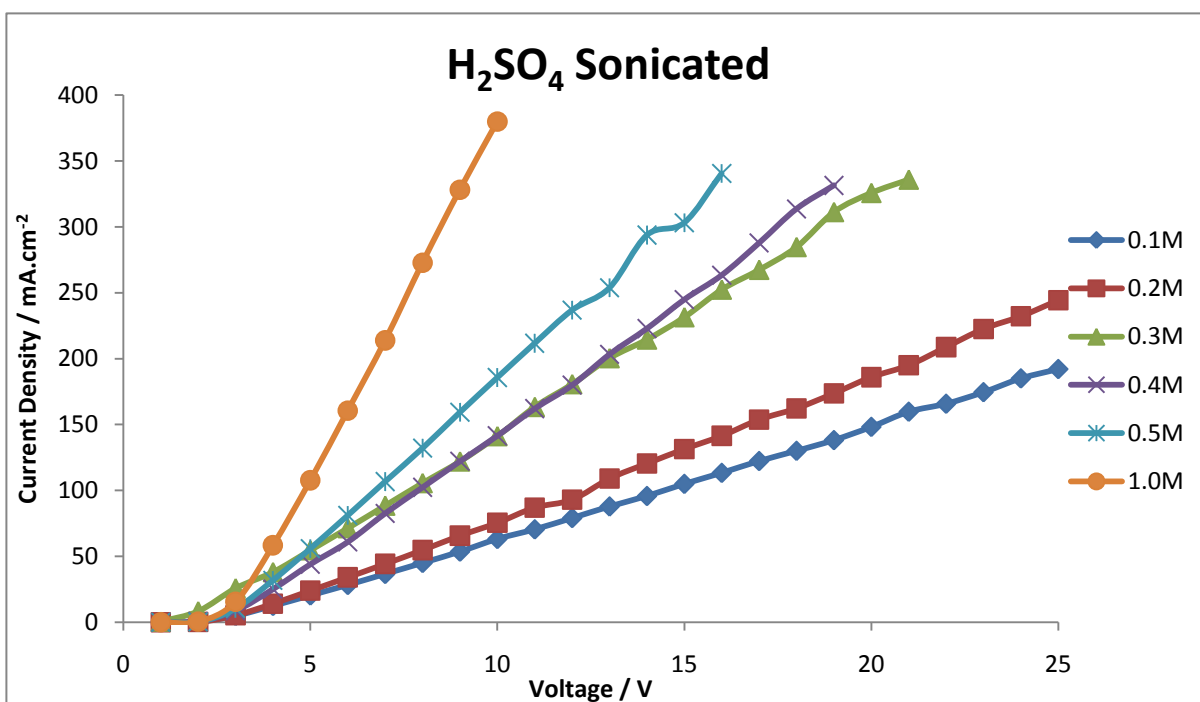

Figure 104: Current Voltage Graph for Sonicated H<sub>2</sub>SO<sub>4</sub> solution

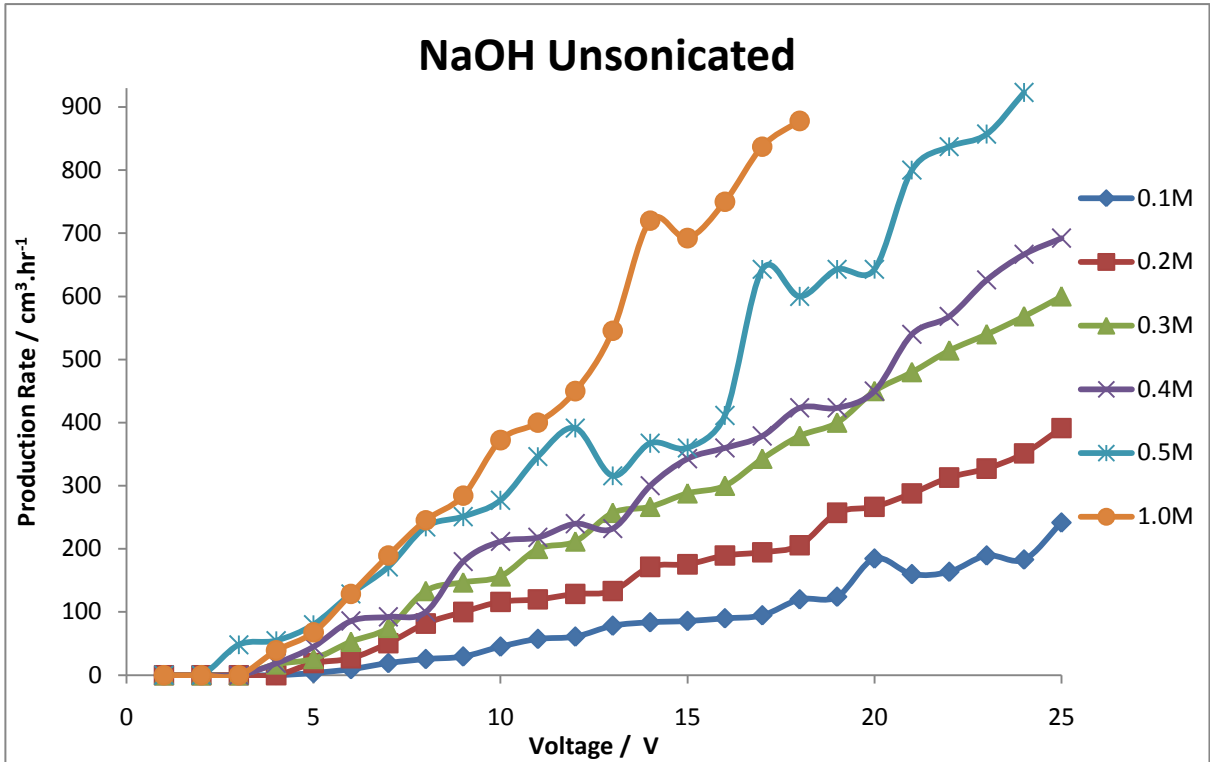

Figure 105: Hydrogen Production Graph for Silent NaOH solution

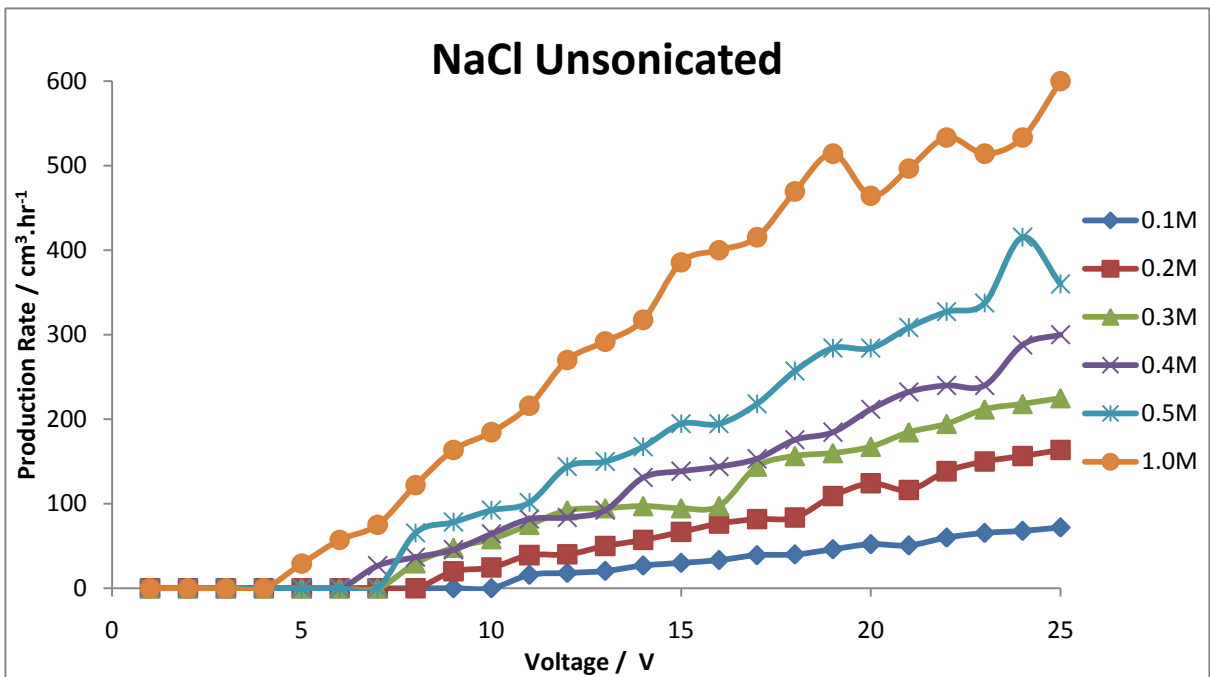

Figure 106: Hydrogen Production Graph for Silent NaCl solution

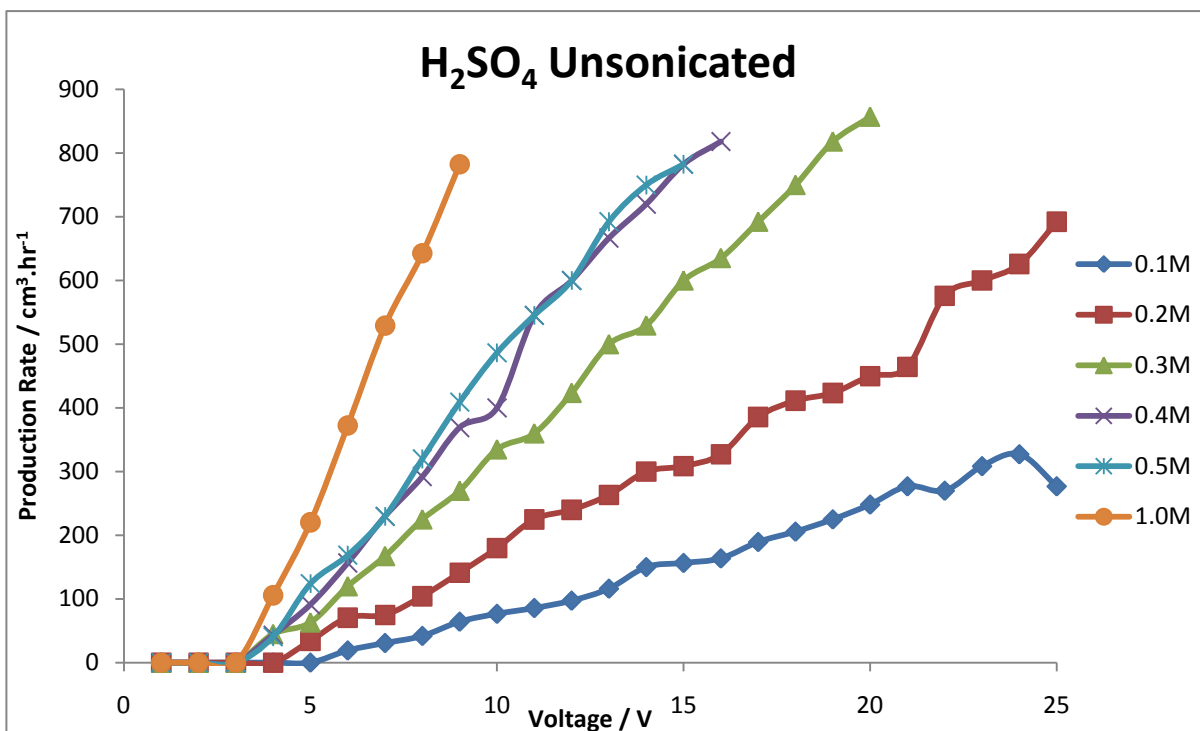

Figure 107: Hydrogen Production Graph for Silent H<sub>2</sub>SO<sub>4</sub> solution

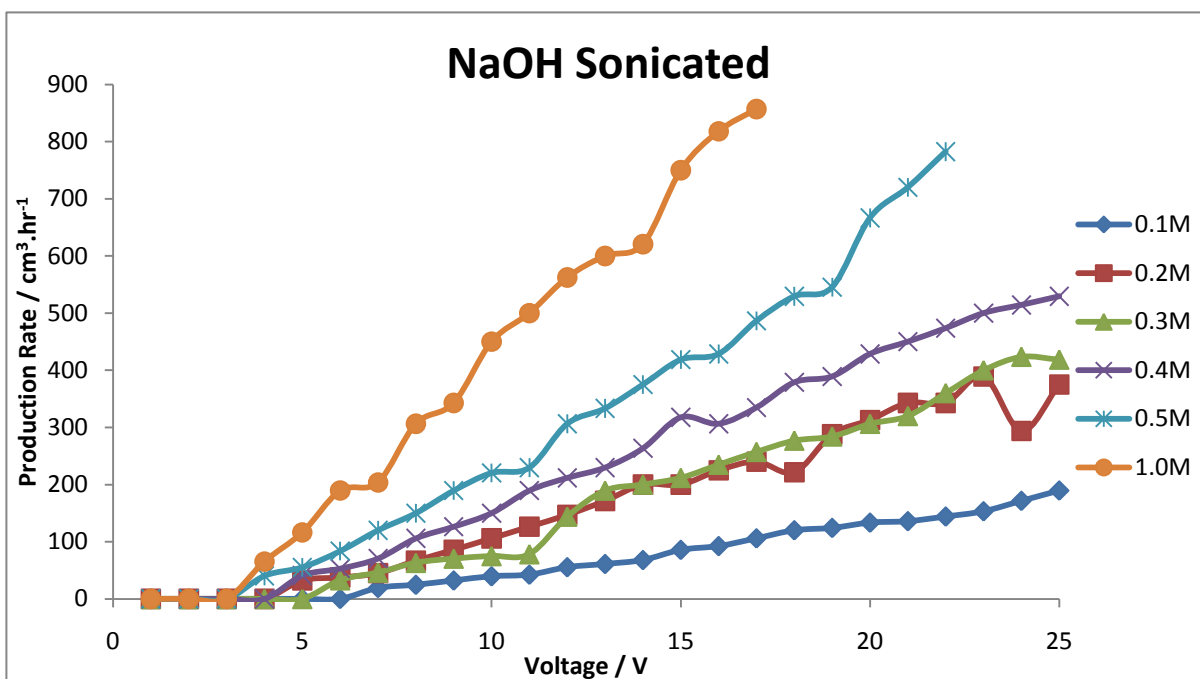

Figure 108: Hydrogen Production Graph for Sonicated NaOH solution



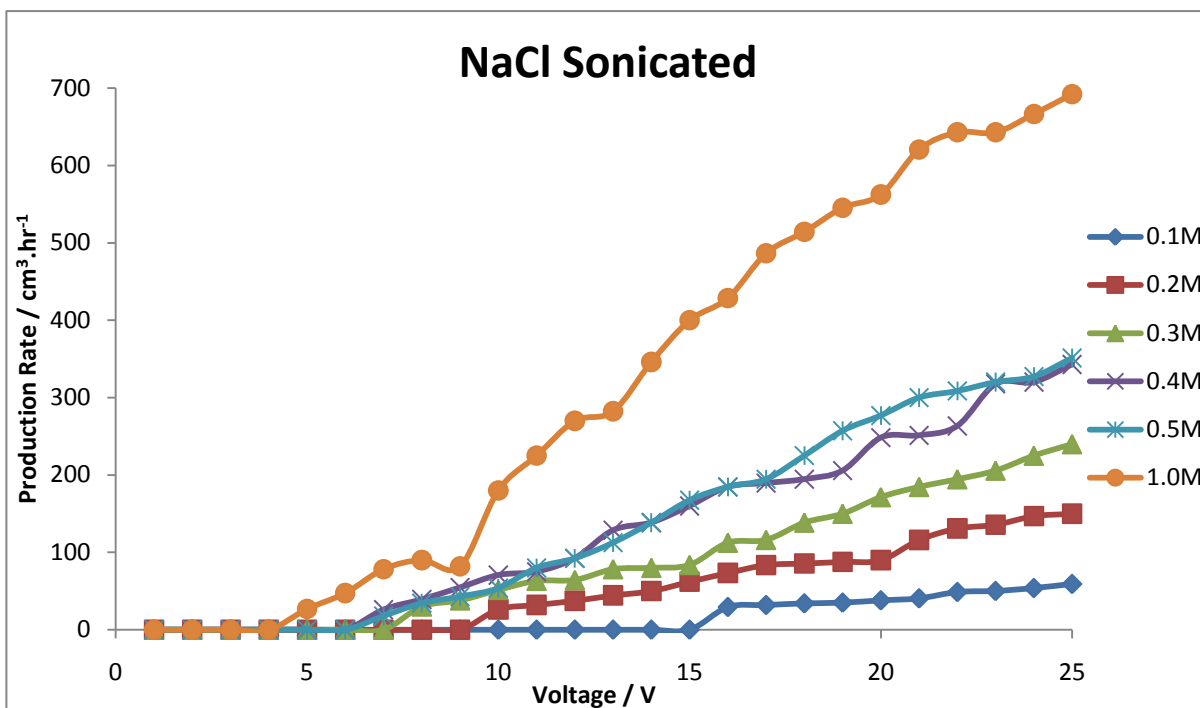

Figure 109: Hydrogen Production Graph for Sonicated NaCl solution

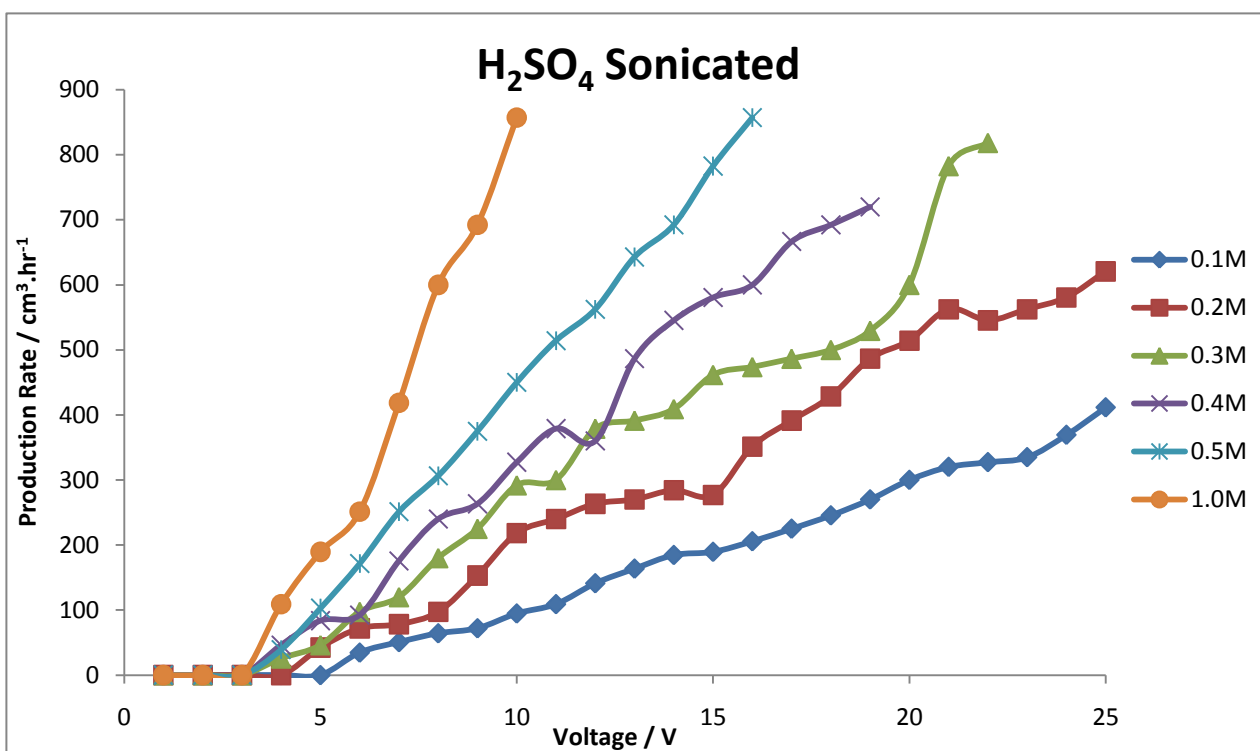

Figure 110: Hydrogen Production Graph for Sonicated H<sub>2</sub>SO<sub>4</sub> solution

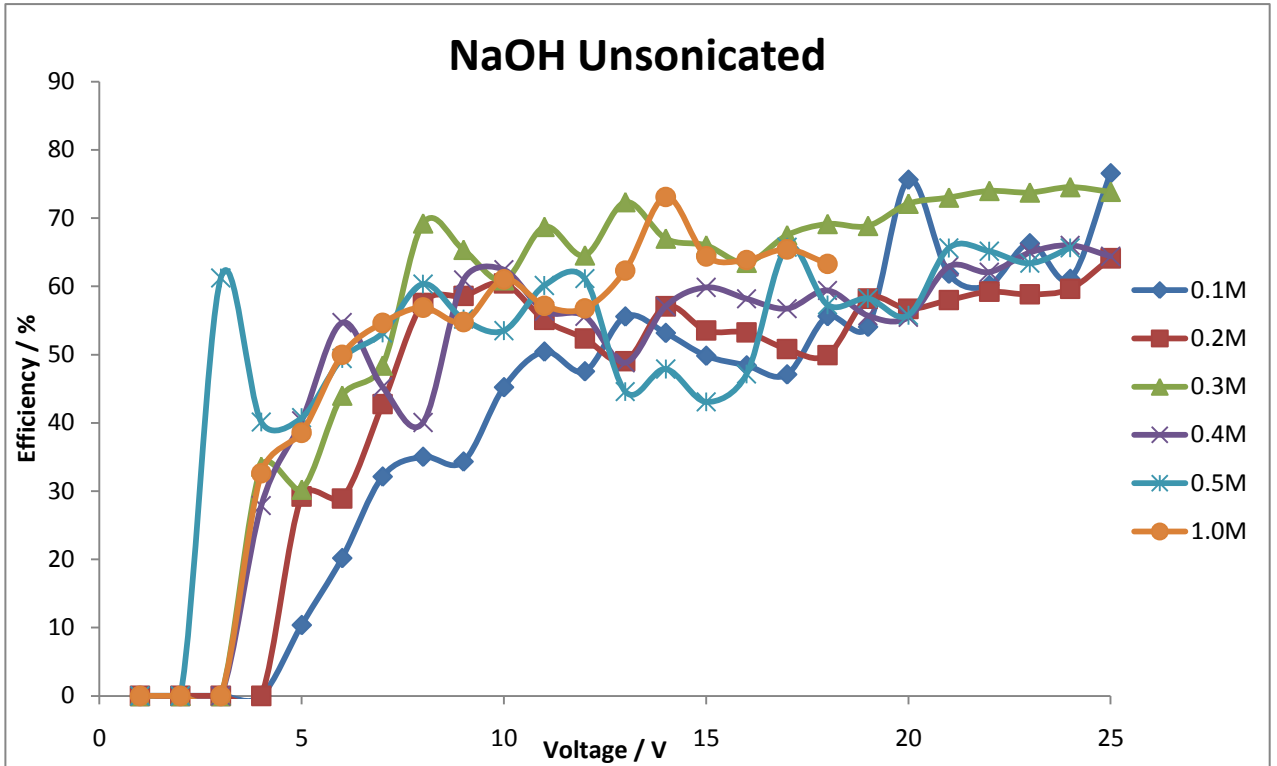

Figure 111: Hydrogen Production Efficiency Graph for Silent NaOH solution

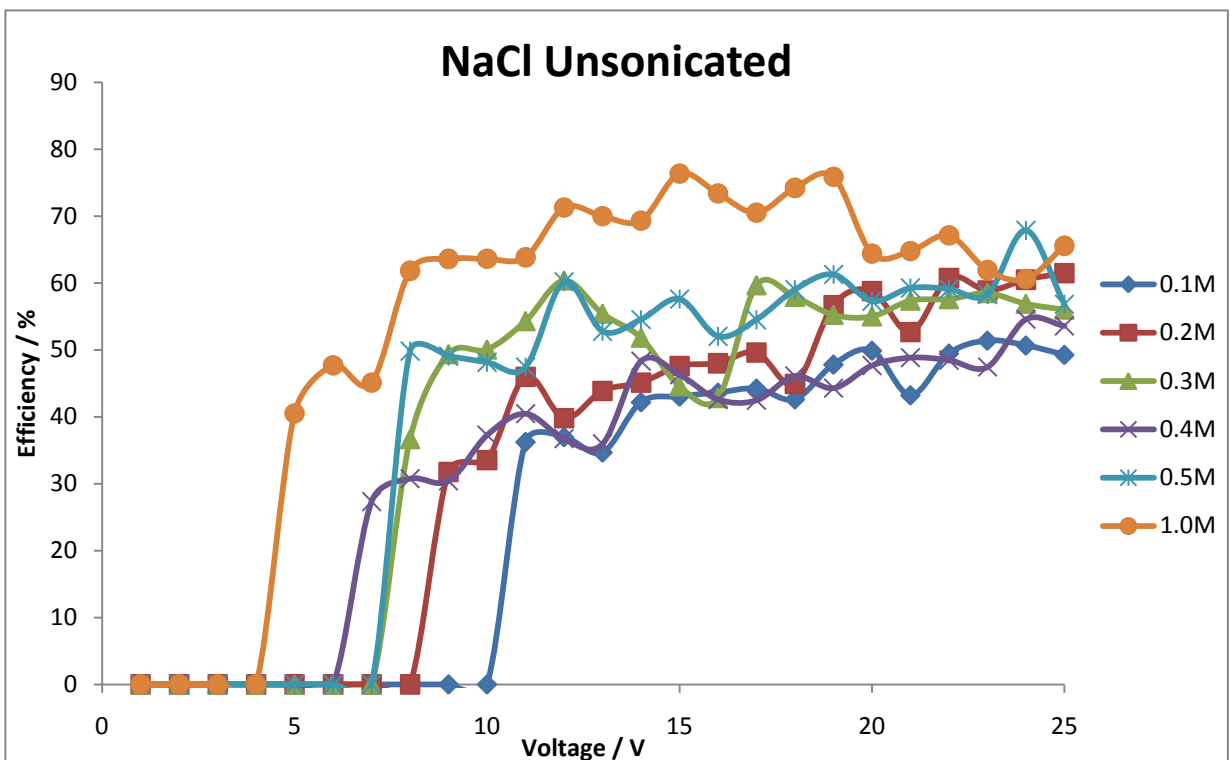

Figure 112: Hydrogen Production Efficiency Graph for Silent NaCl solution

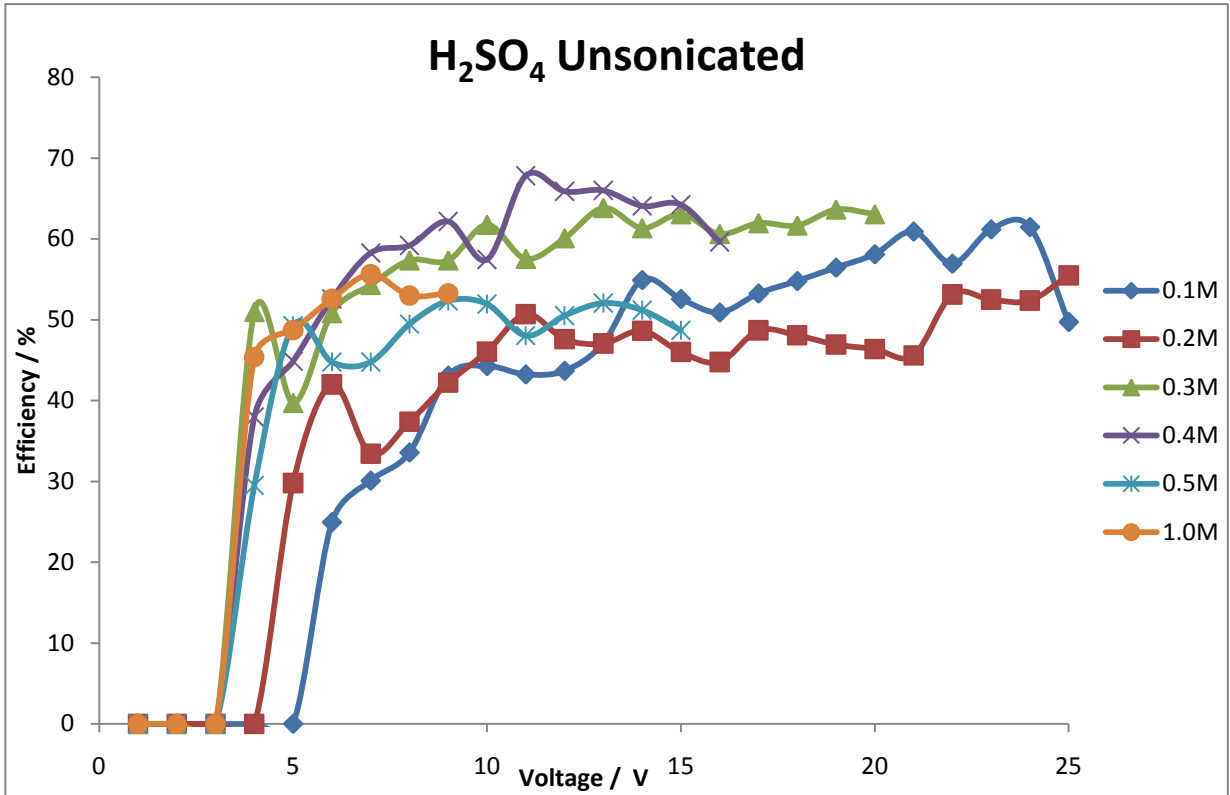

Figure 113: Hydrogen Production Efficiency Graph for Silent H<sub>2</sub>SO<sub>4</sub> solution

**Sonicated**

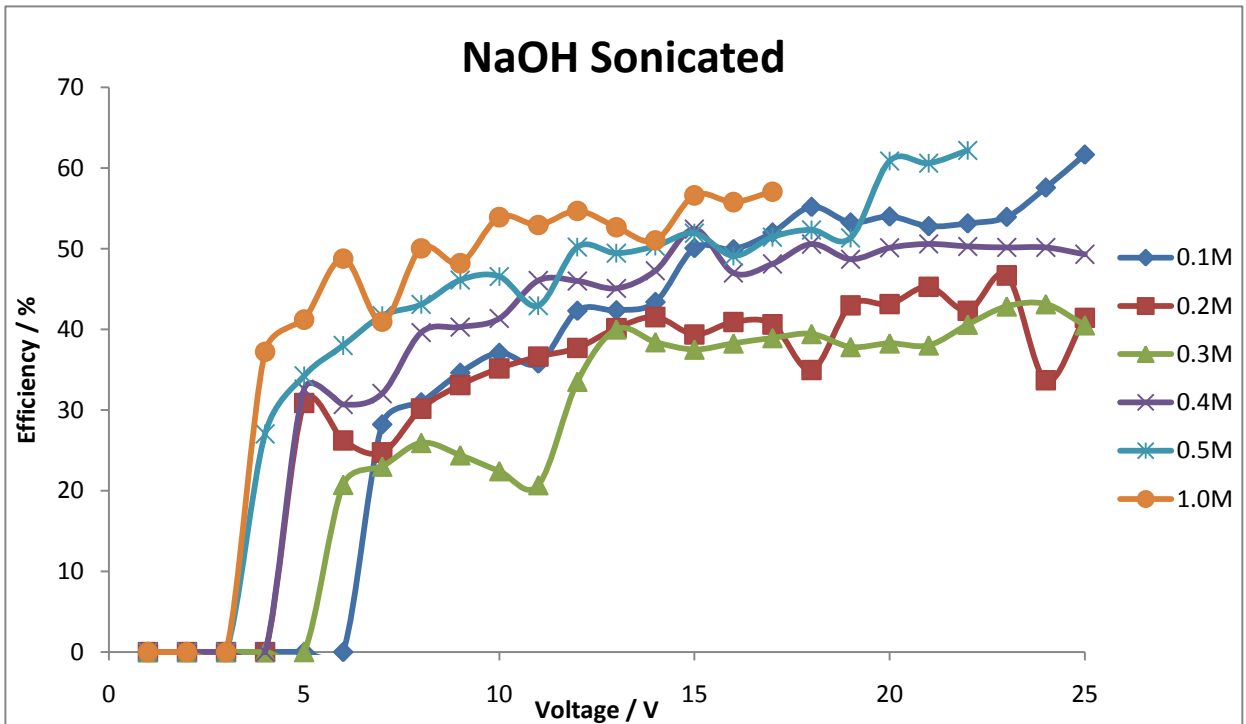

Figure 114: Hydrogen Production Efficiency Graph for Sonicated NaOH solution

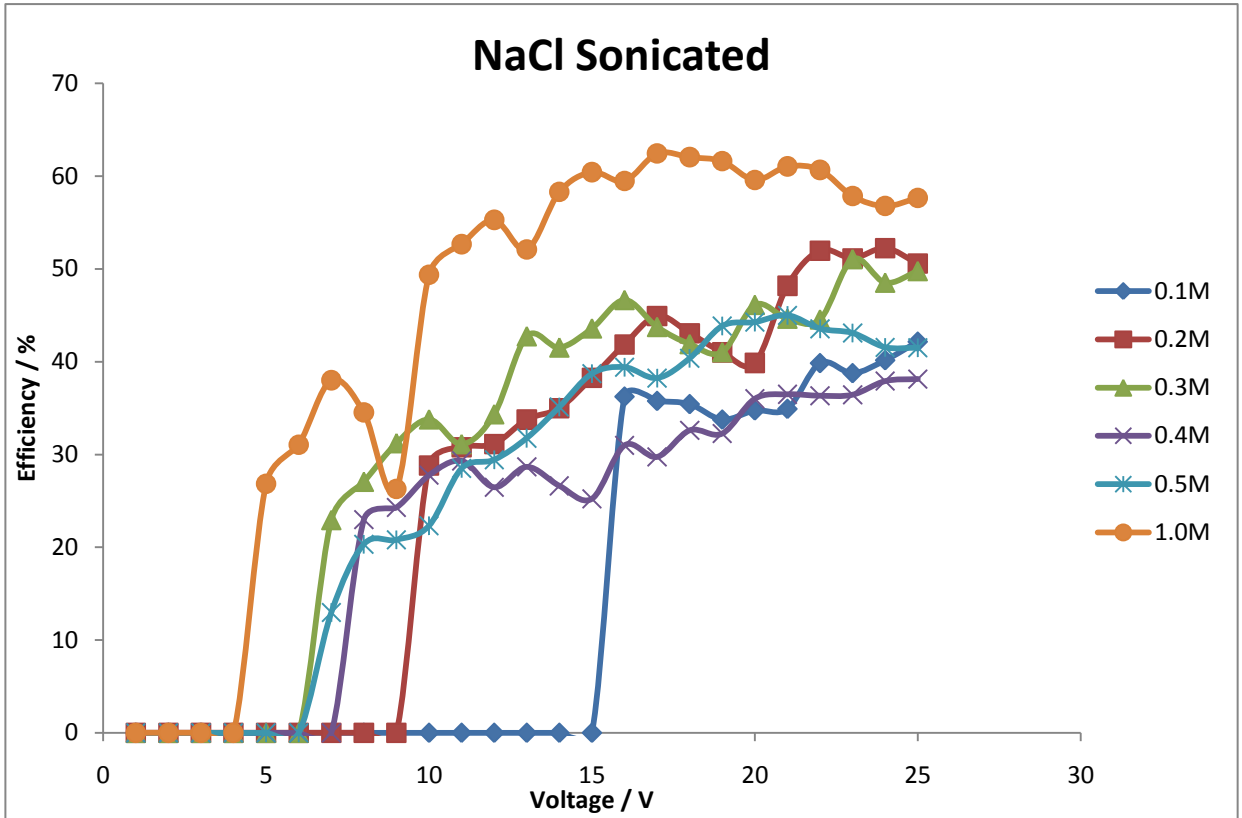

Figure 115: Hydrogen Production Efficiency Graph for Sonicated NaCl solution

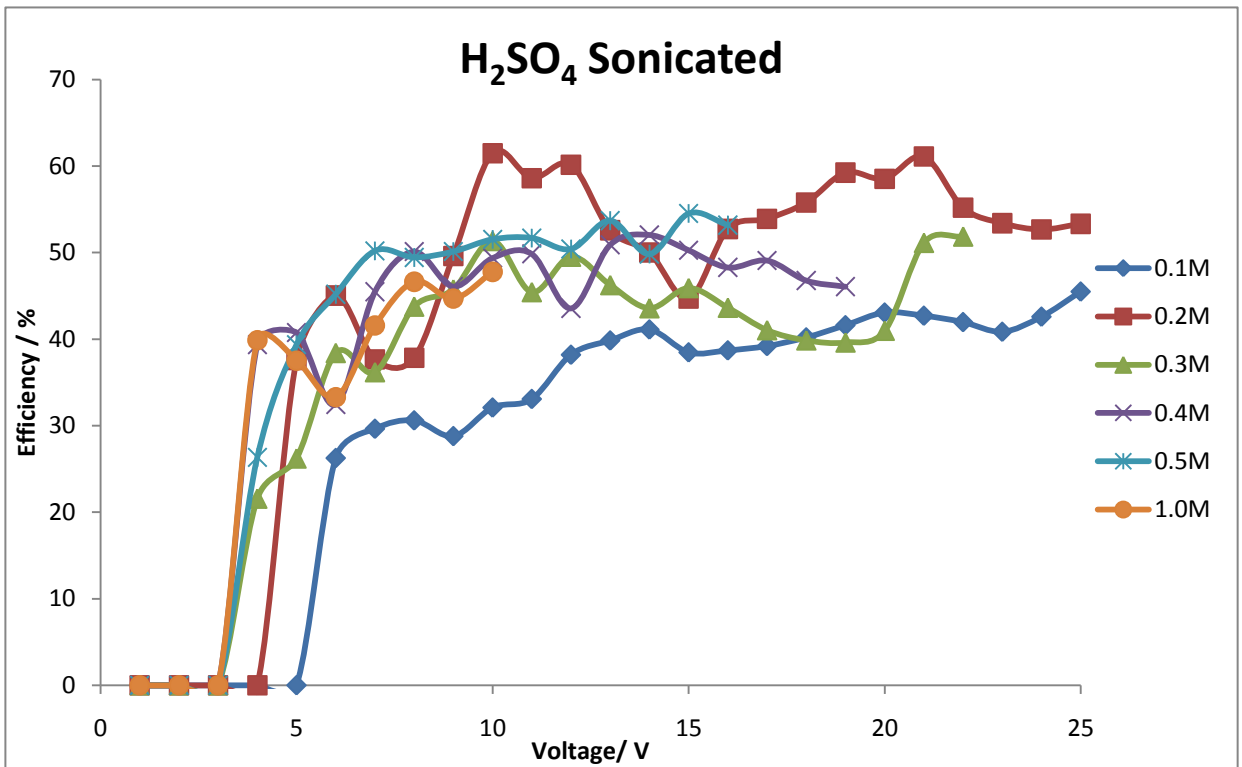
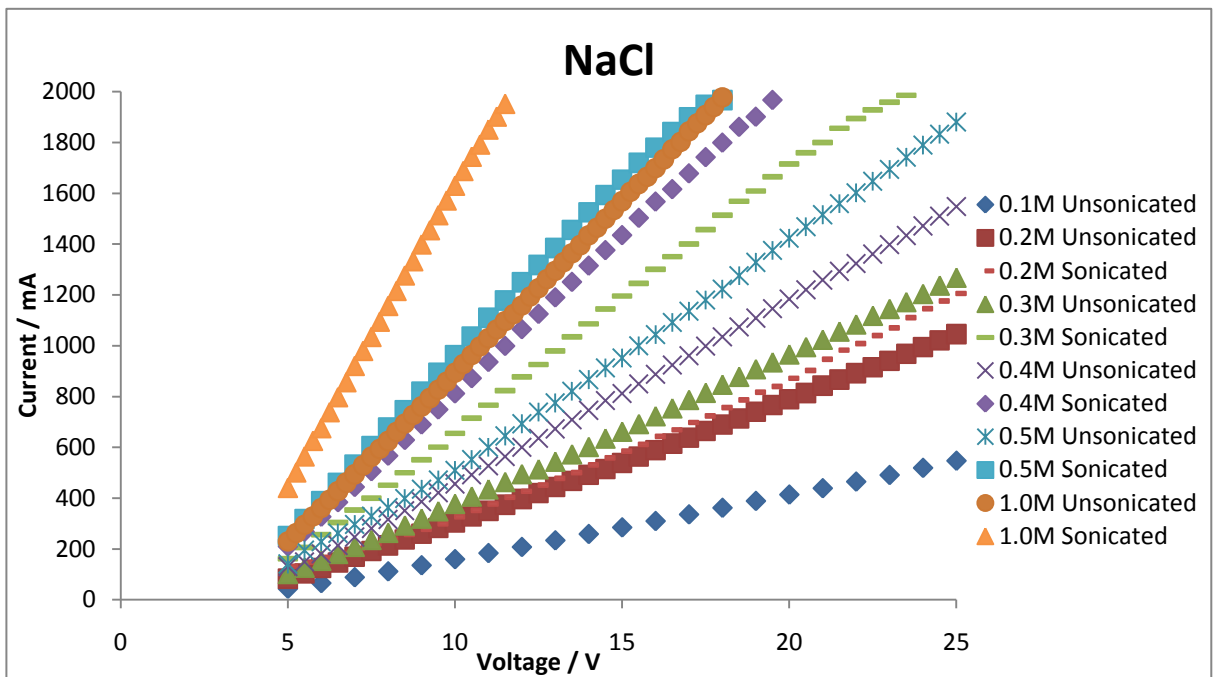
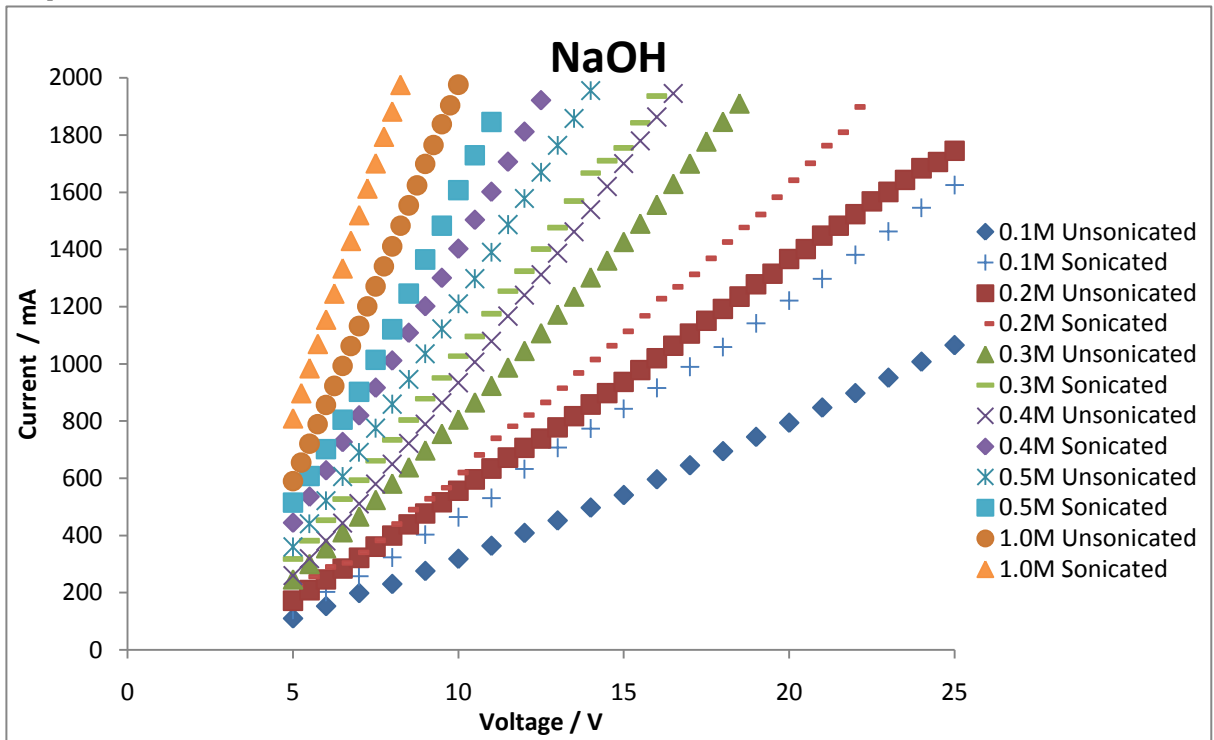
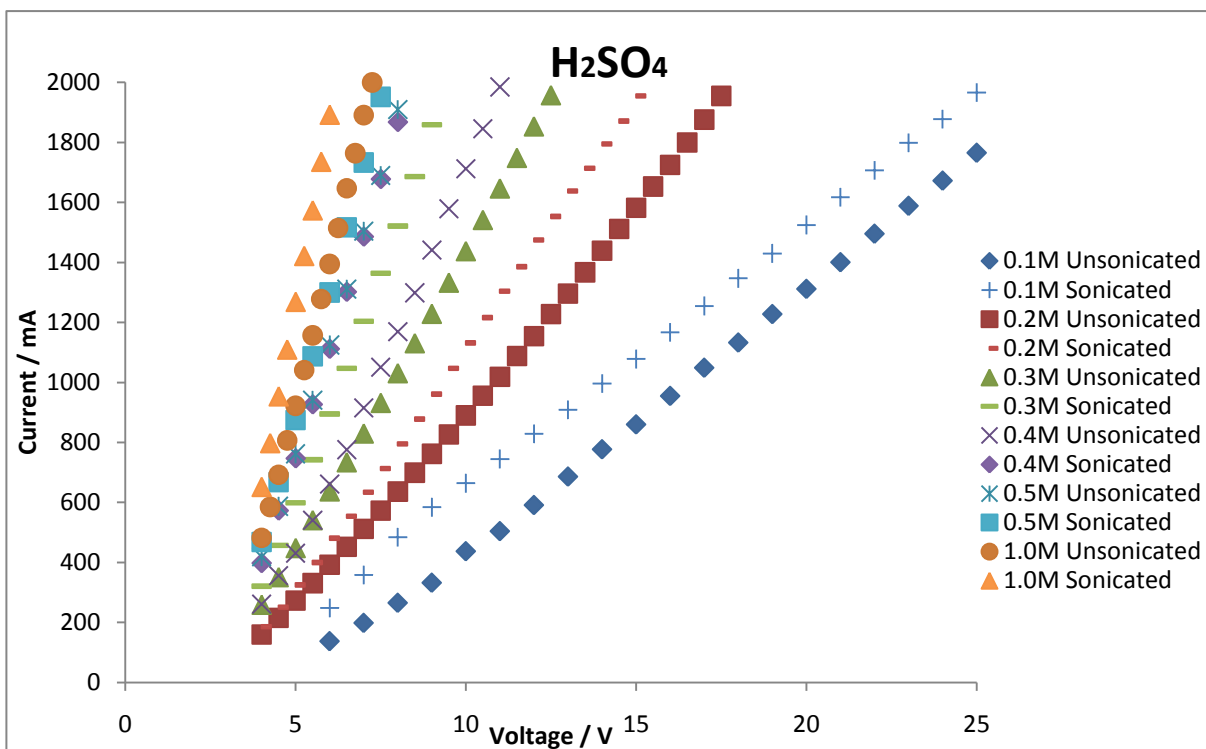

Figure 116: Hydrogen Production Efficiency Graph for Sonicated H<sub>2</sub>SO<sub>4</sub> solution

### 7.3 Appendix III – Decomposition Potential Calculations

#### Graphs





### Equations

Straight Line equations to calculated Decomposition Voltages i.e. when  $y=0$

Electrolyte & Concentration		Silent	Sonicated
NaOH	0.1M	$y = 47.573x - 152.24$	$y = 74.76x - 268.16$
	0.2M	$y = 79.876x - 243.9$	$y = 98.762x - 345.37$
	0.3M	$y = 122.74x - 402.65$	$y = 147.72x - 440.88$
	0.4M	$y = 147.37x - 519.53$	$y = 196.07x - 550.21$
	0.5M	$y = 177.28x - 549.03$	$y = 224.21x - 644.21$
	1.0M	$y = 278.63x - 814.13$	$y = 359.4x - 994.35$
NaCl	0.1M	$y = 25.219x - 90.245$	$y = 34.525x - 122.54$
	0.2M	$y = 48.345x - 175.93$	$y = 54.532x - 205.08$
	0.3M	$y = 58.558x - 206.37$	$y = 100.15x - 329.43$
	0.4M	$y = 71.916x - 257.67$	$y = 121.54x - 398.71$
	0.5M	$y = 87.998x - 344.38$	$y = 133.85x - 385.7$
	1.0M	$y = 134.34x - 447.12$	$y = 234.73x - 724.74$
H2SO4	0.1M	$y = 87.593x - 438.25$	$y = 88.4x - 240.9$
	0.2M	$y = 132.88x - 415.22$	$y = 163.57x - 498.93$
	0.3M	$y = 200.38x - 561.83$	$y = 310.47x - 952.58$
	0.4M	$y = 251.46x - 817.78$	$y = 369.48x - 1094.8$
	0.5M	$y = 370.9x - 1086.6$	$y = 425.05x - 1244$
	1.0M	$y = 472.76x - 1432.4$	$y = 624.61x - 1854.6$

### Industrial Electrolyser Decomposition Voltages

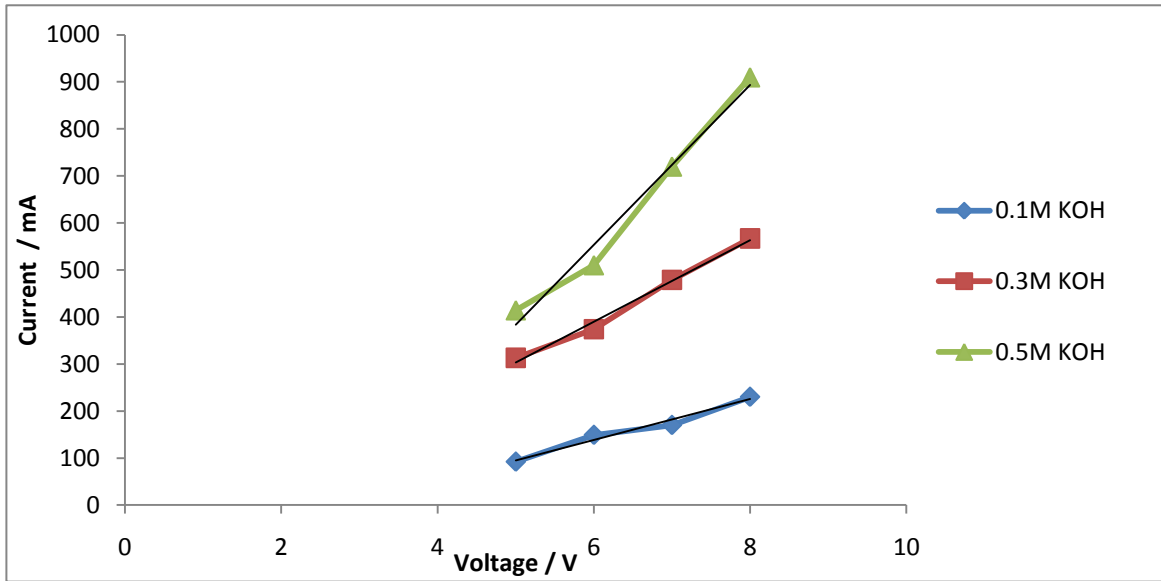

Straight Line equations to calculated Decomposition Voltages i.e. when  $y=0$

Electrolyte & Concentration		Equation
KOH	0.1M	$y = 43.5x - 122.5$
	0.3M	$y = 86.7x - 130.3$
	0.5M	$y = 169.8x - 465.2$

## 7.4 Appendix IV - Ultrasound Power Data Tables

Temperature (K)		Amplitude				
Time (seconds)		20	25	30	35	40
Water	0	297.8	297.9	297.8	297.9	298
	5	298.1	298.2	298.5	298.5	298.8
	10	298.1	298.3	298.3	298.3	298.5
	15	298	298.4	298.3	298.3	298.4
	20	298.2	298.6	298.4	298.4	298.4
	25	298.3	298.5	298.6	298.6	298.5
	30	298.2	298.6	298.5	298.5	298.6
NaOH	0	294.1	294.4	294.4	294.5	294.6
	5	294.2	294.5	294.6	294.7	294.8
	10	294.3	294.5	294.7	294.7	294.9
	15	294.3	294.5	294.7	294.7	294.9
	20	294.3	294.6	294.8	294.7	294.9
	25	294.3	294.4	294.8	294.8	294.9
	30	294.4	294.5	294.8	294.8	295.2
NaCl	0	294.2	294.5	294.9	295.2	295.3
	5	294.3	294.6	295	295.3	295.4
	10	294.4	294.8	295.1	295.4	295.4
	15	294.4	294.6	295.1	295.4	295.5
	20	294.4	294.7	295.1	295.5	295.4
	25	294.4	294.7	295.1	295.5	295.5
	30	294.4	294.7	295.1	295.5	295.5
H <sub>2</sub> SO <sub>4</sub>	0	291.5	291.6	291.8	292	292.1
	5	291.8	291.8	292	292.3	292.5
	10	292	291.9	292.2	292.4	292.6
	15	291.9	291.9	292.3	292.5	292.7
	20	291.8	292	292.3	292.5	292.6
	25	291.9	292.1	292.3	292.6	292.7
	30	291.8	292.1	292.4	292.5	292.7

Figure 117: Temperature variance table for each electrolyte at varying ultrasonic powers

	Temperature Gradient (dT/dt)				
	20	25	30	35	40
Water	0.08	0.12	0.2	0.16	0.24
NaOH	0.023	0.08	0.06	0.066	0.04
NaCl	0.02	0.048	0.02	0.032	0.03
H <sub>2</sub> SO <sub>4</sub>	0.066	0.08	0.06	0.1	0.14

Figure 118: dT/dt gradients calculated for each electrolyte

Amplitude	Ultrasound Power (W)				
	20	25	30	35	40
Water	334.4	501.6	836.0	668.8	1003.2
NaOH	76.8	267.0	200.3	220.3	133.5
NaCl	79.9	191.6	79.9	127.8	119.8
H <sub>2</sub> SO <sub>4</sub>	94.1	114.1	85.6	142.6	199.7

Figure 119: Ultrasound Power Table



## **7.5 Appendix V - Health & Safety**

### ***Appendix Vi - COSHH Forms***





***Appendix VII - Risk Assessment Form***

## **7.6 Appendix VI – Conferences Attended & Posters Presented**

Poster Presented on next page was presented at the following Conferences.

- 6<sup>th</sup> International Conference in HFC, NEC, Birmingham, 25<sup>th</sup> March 25<sup>th</sup> March 2010
- MEG Annual Meeting, Leicester University, April 2010
- Sustainability Conference, NEC, Birmingham, May 2010

