

CoA/N-25

College Note No. 25

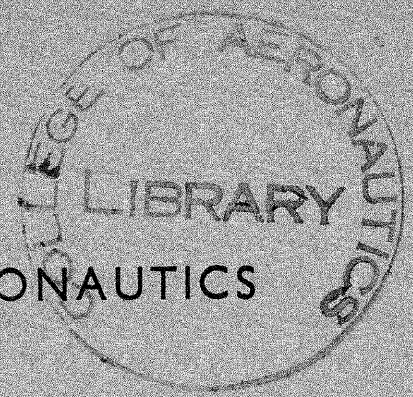

THE COLLEGE OF AERONAUTICS  
CRANFIELD

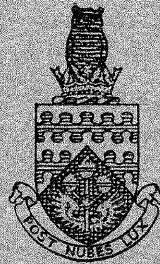

REPORT ON THE MACHINABILITY OF AIRCRAFT  
STEEL D.T.D. 331 (B.S.S. 99) USING H.S.S. TOOLS

by  
J. CHERRY

Q13,27083



3 8006 10057 5722

COLLEGE NOTE No. 25  
APRIL, 1955.

THE COLLEGE OF AERONAUTICS  
CRANFIELD

Report on the Machinability of Aircraft Steel

D. T. D. 331 (B. S. S. 99) Using H. S. S. Tools

- by -

J. Cherry, A. M. I. Mech. E., A. M. I. Prod. E., A. M. I. I. A.

SUMMARY

In all the tests conducted the results obtained were reasonably consistent. High Speed Steel Tools containing 18% Tungsten and 5% Cobalt were used throughout. The same tool was used as far as possible to minimise the variables entering the tool life tests. Basic tests were conducted on a Centre Lathe and the results of these are as follows:-  
Best True Rake Angle = 15°

Feed	Ratio	Speed for one hour tool life Feet/Min.	Surface Finish C. L. A. Microinches
.0025	1 (Datum)	70	120
.005	1.72	60	140
.010	2.57	43	250
.015	3.15	35	450
.020	3.44	29	520

Volume revolvable/Horse Power/minute	= 1.1 cub. inches
Horsepower to remove 1 cubic inch	= 0.91
Vertical Pressure on Tool, P	= 360,000 df. d = depth f = feed
Brinell Hardness	= 402 Bhn
Meyer Hardenability Index 'n'	= 2.18

Tests were conducted to seek a relationship for applying the basic life tests to cylindrical milling. When the maximum undeformed chip thickness was taken as the equivalent of the feed per revolution in turning, the life values showed close agreement.

C O R R I G E N D A

The College of Aeronautics Note No. 25

REPORT ON THE MACHINABILITY OF AIRCRAFT STEEL D. T. D. 331  
(B. S. S. 99) USING H. S. S. TOOLS, by J. CHERRY

FIG 9 ' Maximum deformed chip' should read 'Maximum undeformed chip'

FIG 16 . 070 should read . 010

## CONTENTS

1. Introduction.
2. Experimental Procedure.
3. Discussion of Results.
4. Recommendations.
5. Appendix of Results.

## 1. Introduction.

As a consequence of the greater use of high strength steel components in modern aircraft, machining difficulties have considerably increased. Most materials will yield to machining by tungsten carbide tools where such tools can be employed, as in the case of turning or face milling; however, there are many operations where, owing to the limitations of power or rigidity of existing machines, it is not practical to apply these tools. (The presence of stocks of high speed steel tools may also be an influencing factor in the economics of tool selection.)

It is therefore apparent that data on machining high strength steel with high-speed steel tools should be useful to the aircraft industry.

The investigations to be described were conducted at the suggestion of Messrs. Vickers Armstrongs Supermarine Limited, South Marston, near Swindon, who kindly supplied the material.

The material investigated was a Nickel Chrome Steel of 80/90 tons tensile strength to Ministry of Aircraft Production Specification D. T. D. 331 (B. S. S. 99).

Basic tests to determine tool shape and tool life were conducted on a centre lathe, followed by comparative tests on cylindrical milling to test their validity for this operation.

## 2. Experimental Procedure.

Before commencing the tool life tests it is necessary to determine the optimum tool shape; hence this feature took precedence.

### 2.1 Tool Shape

Only the True Rake angle was the subject of experimentation, being the angle of prime importance. This angle is defined as the angle along which the chip flows, and since side cutting tools were used as illustrated in Figs. 2 and 3 the True Rake angle for these tests is co-incident with the Side Rake angle.

Should the practical application permit the use of a Plan Approach angle, this is recommended, as the distribution of the cutting load over the longer cutting edge increases tool life.

A radius of  $1/32''$  was arbitrarily chosen as being the minimum radius likely to be permitted in aircraft practice; larger radii should give slightly increased tool life.

Two experimental techniques were employed in determining the most suitable True Rake angle, by:-

2. 11 Measuring Cutting Loads on the Tool

2. 12 Measuring Tool Life

2. 11 Measuring Cutting Loads on the Tool

In this method the vertical and horizontal cutting loads on the tool are measured on a dynamometer as shown in Fig. 1.

A series of tools of  $\frac{1}{2}''$  square section with varying True Rake angle as shown in Fig. 2 was used and the Vertical and Horizontal loads on the tools recorded.

Figs. 11 and 12 show the curves plotted from these results.

Inspection of the curves by an experienced observer enables a close approximation to the optimum angle to be made.

This technique should only be regarded as a first approximation; however, it has the advantage of quickly providing a close answer, it is also economical in the consumption of material and is non-destructive to the tool.

2. 12 Measuring Tool Life.

In this method, tools as similar as possible (except for varying True Rake angle) were subjected to identical cutting conditions and the time taken to destruction was recorded.

To reduce the error arising when different tools are used the type of tool chosen had four cutting edges as shown in Fig. 3. Each edge had a different True Rake angle. These tools were used in a Clamp-Tip holder as shown in Fig. 4.

When more than one tool was required these were selected from the same length of tool bit thus minimising differences in material and heat treatment.

Fig. 13 shows the type of curve obtained from the results of this test.

Choice of True Rake angle is conclusive from these results.

## 2. 2. Tool Life Tests

Tests were conducted with the objective of determining the relationship between Tool Life and Cutting Speed at different rates of feed.

F. W. Taylor found the approximate relationship of these factors could be expressed in the form

$$VT^a = C$$

where V = Speed (F. P. M.) Surface feet per minute  
T = Life (Min.)  
C = Constant (dependent on material and conditions)  
a = Exponent (dependent on material and conditions)

The results obtained were reasonably in accordance with this formula.

Bearing in mind that one of the principal applications of the results of this investigation would be to the milling process, two criteria for the determination of tool life were chosen, these were:-

2. 21 Width of Flank Wearland

2. 22 Depth of Crater on Top Face, as illustrated in Fig. 5.

2. 21 Width of Flank Wearland

The maximum width of flank wearland permitted was 0.030".

Owing to the work hardening induced in the material by a blunt tool very little increase of flank wearland above 0.030" could be tolerated without the complete breakdown of the cutting edge.

Measurement of Flank Wearland was made on a Toolmakers microscope as shown in Fig. 7.

2. 22 Depth of Crater

The maximum depth of crater permitted was 0.005".

In a milling application where some eccentricity is inevitable it is possible that although the average crater would be 0.005" deep a high tooth may have as much as 0.007" wear. To regrind such a cutter would require at least 0.010" to be removed from the face and this is considered a reasonable amount to compromise between cutting time, tool life and grinding time.

The life of the tool was taken as the lesser time to reach one or the other of the foregoing criteria.

In the event of these criteria being exceeded a correction was made pro-rata, experiment having shown that wear was roughly proportional to time under constant conditions.

Measurement of the depth of crater was made on the Taylor Hobson Talysurf Surface Recorder.

Figs. 14 and 15 show the Tool Life Curves plotted from the results obtained.

### 2. 23 Application to Cylindrical Milling

To check the validity of the results obtained in turning when applied to cylindrical milling, tests were made on a horizontal milling machine using a fly cutter of the approved shape mounted in a cutter body as illustrated in Fig. 6.

A series of cuts was taken along the test piece under similar conditions to those employed in the turning tests, and the length of metal machined up to tool failure was calculated. This value was converted to the equivalent life in minutes for continuous cutting and compared with the relative life for turning.

A relationship was found between the tool life for cylindrical milling and turning when the maximum chip thickness was compared with the rate of feed in turning. This statement is amplified in the discussion of the results.

### 2. 3 Horsepower Requirements

To give guidance to estimators regarding power consumption a series of turning tests was conducted to measure the cutting loads at different rates of feed and depths of cut.

The law relating these to the vertical load on the tool is of the form

$$P = Kd^x f^y$$

where P = Vertical load  
d = depth of cut  
f = rate of feed  
K = constant (for material and conditions)  
x and y = exponents (for material and conditions)

Fig. 16 shows the results obtained.



## 2.4 Surface Finish

The surface finished obtained when using the rates of feed employed in the tests were recorded for guidance when this measurement has to be considered.

The Talysurf was used for this and examples are shown in Fig. 8.

## 2.5 Hardness Tests

Hardness was measured by the Brinell test using a 10 mm. ball with a 3,000 Kg. load. The Meyer hardenability index was also determined. The latter value gives a measure of the strain hardenability characteristic of the material and is determined from the relationship

$$L = ad^n \quad \text{where} \quad \begin{array}{l} L = \text{load} \\ d = \text{diameter of impression} \\ a = \text{constant} \\ n = \text{Meyer exponent} \end{array}$$

## 3. Discussion of Results

### 3.1. Determination of True Rake Angle

In the tests on which the time taken to destruction was the criterion, a true rake angle of  $15^\circ$  gave the longest life. Table 2 shows the results obtained which are plotted on Fig. 13. Two rates of feed, 0.005 and 0.020" were chosen for these tests, and since both indicated that a true rake angle of  $15^\circ$  gave the longest life, further tests on the intermediate feed rates of 0.010 and 0.015" were deemed unnecessary.

As with all comparative experiments the same tool was used for each set of tests.

Table 1 gives the Results of the measurement of Vertical and Horizontal loads on the cutting tool for various true rake angles. The vertical loads are plotted on Fig. 11 and the horizontal on Fig. 12.

Inspection of these curves reveals a considerable reduction in the load on the tool as the true rake angle increases up to  $20^\circ$ .

The curves for the 0.015" rate of feed show an increase in load when  $20^\circ$  is exceeded. This is probably due to the early breakdown of the cutting edge and gives warning of tool weakness, hence for prolonged use even a tool with  $20^\circ$  would be suspect, therefore one would be inclined to choose  $15^\circ$ .

Examination of the Vertical load curve for 0.005" rate of feed shows 15° to be satisfactory for this case also. Since there is little reduction in load on tools with angles of 15°, 20°, 25°, the longest life would be expected from the tool with the greatest volume to dissipate heat. The above reasoning is merely stated to show that, although not conclusive, cutting load measurements, when interpreted with caution, can speedily provide a first approximation to optimum tool geometry.

### 3.2 Tool Life Tests

This series of tests was conducted to establish the speed and life relationship for a preferred range of feed rates, thus permitting optimum cutting conditions to be selected for a useful range of common feeds.

As previously mentioned the criterion chosen was 0.030" flank wearland or 0.005" crater whichever occurred first. Depth of crater was measured on a Talysurf surface roughness recorder and a sample trace is shown in Fig. 10.

The results of these tests are shown in Table III and the curves plotted on Fig. 14.

Fig. 15 shows the curves plotted on a log-log scale and extrapolated to a 60 minute tool life. Since the slope of the curves is parallel for the different feed rates it was only necessary to establish one slope accurately then determine the displacements of the other feed rates. This economises on material. Providing material and time are available, it is preferable, of course, to conduct tests in the region of 30 minutes for each series.

Examination of Fig. 14 enables an economical analysis to be made in the selection of the cutting speed, when considered in relation to tool changing time.

In selecting speeds from the curve it is recommended that the lower values in the band are taken.

It will be noted that the tool life values for tools 'X' and 'Y' fall within the same band for 0.005" feed/rev. although these tools made a depth of cut of 0.10" compared with 0.050" depth for tools 'Z' and 'W'. This appears to indicate that, providing there are adequate facilities for heat dissipation, tool life was unaffected by depth of cut.

Fig. 17 is plotted from the values shown in Fig. 14 and enables speeds to be selected for a given tool life for intermediate rates of feed.

Fig. 18 shows the rate of metal removal for one hour's tool life at various rates of feed and indicates that a feed rate of 0.020" is the most efficient, providing surface finish is not a criterion. Surface Finish results are dealt with under section 3.4.

All tests were made with an Eclipse brand H. 3 H. S. S. tool containing 18% Tungsten and 5% Cobalt, Hardness, Rockwell 'c' Scale 65/67, hence if tools of lesser quality are used, speeds will have to be reduced for a given tool life and vice versa. Also the coolant used was soluble oil at 10/1 dilution applied in an overhead stream at approximately 1 gallon per minute and any variation from this will require the appropriate compensation in selecting the speed from the chart.

### 3.21 Application to Milling

Tools with the shape corresponding to that used in the turning tests were applied to horizontal milling as shown in Fig. 9.

Two test runs were made at 0.056" feed per rev. and one at 0.040". Results are shown in Table IV.

The depth of cut was 0.10" and the width of cut 0.050". In Test 1 using 0.056" feed/rev. 17 passes of 12" long were made before tool failure. Nineteen passes were made in Test 2 using 0.040" feed/rev.

Shown in the table is the total length of metal passing the tool, also the equivalent tool life when converted to continuous cutting as in turning.

When the maximum undeformed chip thickness is chosen as the criterion there is found to be reasonable agreement with the results from the turning tests, as shown on Fig. 14.

The procedure for selecting a speed for horizontal cylindrical milling would be as follows:-

1. Select cutter life required.
2. Determine life per tooth (equivalent continuous cutting time)
3. Determine maximum undeformed chip thickness.
4. Select Speed for the selected tool life.

### Example

1. Assume one shift between regrinds, say 8 hours
2. Assume a cylindrical cutter 4" dia. with 10 teeth taking 0.1 depth of cut at 0.010" feed per tooth.

$$\text{Ratio } \frac{\text{Cutting time per tooth}}{\text{Cutting time for cutter}} = \frac{\text{length of engagement 'l'}}{\text{circumference}} = 0.05$$

Equivalent continuous Cutting time per tooth =  $0.05 \times 8 \times 60 = 24$  minutes  
(From Fig. 19)

3. Determine maximum undeformed chip thickness.  
This is obtained from Fig. 20 and in the example chosen the value is 0.003" approx.
4. Using Fig. s 14 or 17 select speed to give 24 minutes tool life at 0.003" feed per rev. = 90 feet/minute.

### 3.3 Horsepower Tests

These tests were conducted on a Centre Lathe and the results apply to turning and boring operations. Table V shows the results obtained which are plotted on Fig. 16. The exponentials  $x$  and  $y$  for depth of cut and rate of feed respectively were both found to have values of 1.

Since the horsepower required increases with the wear of the tool a test was made when the wearland equalled 0.030" and the results of this are quoted as being of more practical value.

### 3.4. Surface Finish Tests

To give guidance with regard to the surface finish produced by the various rates of feed used in the experiments, these were measured on a Taylor, Taylor and Hobson Talysurf recorder and the results are shown in Table VI. The surface contours at a vertical magnification of 1,000 and a horizontal magnification of 100 are shown in Fig. 8.

### 3.5. Hardness Tests

The Brinell hardness result of 402 Bhn showed the material was up to standard giving an approximate tensile strength of 88 tons/square inch.

The Meyer exponent 'n' of 2.18 indicates that the material is not excessively prone to strain hardening.

#### 4. Recommendations

4. 1. A True Rake angle of  $15^{\circ}$  should be used. This gave best results in the basic turning tests and the cylindrical milling tests showed reasonable agreement with the results obtained.

4. 2. Figs. 14 and 17 should be used for selecting the speed for a given tool life and feed rate.

Adjustments should be made if the tool differs substantially from the test tool, also if the coolant is materially altered.

4. 3. Adequate coolant should be supplied, preferably of an E. P. ( Extreme Pressure) type.

4. 4. Figs. 19 and 20 should be used to enable Figs. 14 and 17 to be applied to cylindrical milling.

4. 5. Feed per tooth should be as great as possible (within the limitation of surface finish and tool strength), to minimise rubbing of the cutting edge.

5. Results

5.1 Determination of True Rake Angle

5.11 Measurement of Cutting Loads on Tool

Equipment

Machine - Centre Lathe, No coolant used, Depth of Cut 0.10",  
Cutting Speed 35 F. P. M.

Work Material - D. T. D. 331

Tool - 18% Tungsten 5% Cobalt H. S. S. 'Eclipse' brand H. 3  
Hardness, Rockwell 'C' Scale 65/67,  
Top Rake = 0°, Plan Angle = 0°, Clearance Angle = 6°,  
Nose Radius =  $\frac{1}{32}$  "

Feed /Rev.	0.005"		0.008"		0.010"		0.015"		
	Vert.	Hor.	LOADS IN POUNDS						
True	5°	180	118	325	170	400	248	550	308
		152	113	305	160	395	210	470	248
Rake	15°	152	100	285	120	350	200	455	214
		151	91	275	115	278	135	364	157
Angle	25°	150	90	270	103	273	95	443	176
				260	95				

TABLE I. Vertical and Horizontal loads on tool for varying True Rake angles.

### 5.12 Life Measurement of Tool Angle

#### Equipment

Machine - Centre Lathe. Depth of cut 0.050". Cutting Speed 130 F. P. M.  
No coolant used.  
Material - D. T. D. 331  
Tool - 18% Tungsten 5% Cobalt H. S. S. 'Eclipse' brand H. 3.  
Hardness, Rockwell 'C' Scale 65/67, mounted in Clamp-tip  
Toolholder (See Fig. 4.)  
Top Rake = 0°, Plan Angle = 20°, Clearance Angle = 6°  
Nose Radius =  $\frac{1}{32}$ "

Feed /Rev.		0.005	0.020
		Life (Mins.)	
True Rake Angles	5°	1.65	1.25
	10°	2.12	1.50
	15°	2.6	2.1
	20°	0.9	.1

TABLE II. Tool Life in minutes for varying True Rake Angles

5. 2 Tool Life Tests

5. 21 Centre Lathe Tests

Equipment

Machine - Centre Lathe

Material - D. T. D. 331

Tool - H. S. S. "Eclipse" brand H. 3 Hardness Rockwell 'C' Scale 65/67  
 Mounted on Clamp-tip Toolholder (See Fig. 4)  
 Top Rake 0°, Plan Angle 20°, Side Rake 15°, Clearance  
 angles 6°, Nose radius  $\frac{1}{32}$ "

Soluble Oil - Shell Mex M. 3, dilution 1/10

Toolmaker's Microscope - Taylor Hobson Talysurf.

Tool	Rate of Feed	Depth of Cut	Speed	Flank Wear-land	Top Wear-land	Depth of Crater	Life mins. .030" Flank Wear-land or .005 depth of crater
Z	.005	.050	135	Failed	-	-	1.72
Z	.005	.050	100	.034	-	-	9.7
Z	.005	.050	90	.032	.036	.002	12.8
W	.005	.050	135	Failed	-	-	2.5
W	.005	.050	115	Failed	-	-	7
W	.005	.050	100	Failed	-	-	13.2
P	.005	.050	65	.031	.046	-	41.5
V	.010	.050	112	Failed	-	-	1
V	.010	.050	106	Failed	-	-	2.7
V	.010	.050	83	.029	.062	.007	7.3
T	.020	.050	80	Failed	-	-	1.7
T	.020	.050	73	Failed	-	-	2.25
T	.020	.050	63	.016	.070	.004	5
A	.0025	.050	144	.030	-	-	2.15
A	.0025	.050	133	.032	-	-	6.6
A	.0025	.050	118	.030	-	-	9.1
X	.005	.10	135	Failed	-	-	0.97
X	.005	.10	99	.030	-	-	10.9
X	.005	.10	90	.030	-	-	15
Y	.005	.10	127	Failed	-	-	2.5
Y	.005	.10	109	Failed	-	-	6.0

TABLE III. Tool Life for Various Speeds and Rates of Feed.

Values in Formula  $VT^a = C$

a = 0.317, Feed/Rev. 0.0025" C = 230, Feed/Rev. 0.005" C = 200,  
 Feed/Rev. 0.010" C = 150, Feed/Rev. 0.020" C = 100



5. 22 Milling Tests.

Equipment

Machine - Horizontal Miller as illustrated in Fig. 9

Material - D. T. D. 331

Tool - H. S. S. 'Eclipse' H. 3 Hardness Rockwell 'C' Scale 65/67  
mounted in Cutter Body as shown in Fig. 6.

True Rake angle  $15^{\circ}$ , Clearance Angles  $6^{\circ}$ , Nose radius  $\frac{1}{32}$ "

Coolant Soluble Oil

	Test 1	Test 2	Test 3
Feed per Rev.	0.056	0.040	.026
Radius of Cutter	2.75	2.75	2.25
R. P. M.	60	60	60
Cutting Speed F.P.M.	86.5	86.5	70
Depth of Cut	0.1	0.1	0.1
Width of Cut	0.05	0.05	0.05
Total Length L	12"	12"	12"
No. of Passes	17	19	41
Chip Length 'l'	.77	.77	.71
Total metal passing tool	$\frac{12}{.056} \times .77 \times 17$ = 2880"	$\frac{12}{.040} \times .77 \times 19$ = 4380"	$\frac{12}{.026} \times .71 \times 41$ = 13,400
Equivalent life for continuous cutting	$\frac{2880}{86.5 \times 12}$ = 2.7 mins.	$\frac{4380}{86.5 \times 12}$ = 4.2 mins.	$\frac{13400}{70 \times 12}$ = 16 mins.
Maximum chip thickness	0.015"	0.011"	0.08"

TABLE IV. Horizontal Milling Results

For calculations for maximum chip thickness and chip length see Fig. 9.

5. 3 Horsepower Tests  
Equipment.

Machine - Centre Lathe

Material - D. T. D. 331

Tool - H. S. S. 'Eclipse' H. 3

True Rake  $15^{\circ}$ , Cutting Speed 50 F. P. M. Clearance Angles  $6^{\circ}$   
Dynamometer

Depth of Cut	Rate of Feed	Vert. Load	Horizontal Load
.050	.0025	30	35
.050	.005	75	50
.050	.010	160	90
.050	.020	300	125
.10	.010	295	
Values when above tool has .030" wearland			
.10	.010	360	

TABLE V. Loads on Tool at various Rates of Feed.

Numerical Values in Formula  $P = Kd^x f^y$

From experimental results  $x = 1$ ,  $y = 1$ ,  $K = 360,000$ ,  $P = 360,000df$ .

Where  $P$  = Vertical Load on tool

$d$  = depth of cut

$f$  = feed rate

The above relationship applied to the Vertical load on the tool when the wearland has reached 0.030".

Under this condition

the Volume/Horse Power/minute = 1.1 cubic inches

Horsepower to remove 1 cubic inch = 0.91

#### 5.4 Surface Finish Tests

##### Equipment

Machine - Centre Lathe  
Tool - H. S. S. 'Eclipse' H, 3 mounted in Clamp tip toothholder  
True Rake Angle  $15^{\circ}$ , Nose radius  $1/32''$ , Flan angle  $20^{\circ}$   
Clearance Angles  $6^{\circ}$ , Depth of cut  $0.050''$   
Speed 90 F. P. M.  
Coolant - Soluble Oil 1/10

Feed	.0025	.005	.010	.015	.020
Surface Finish					
C. L. A.	120	140	250	450	520

TABLE VI. Surface Finish in C. L. A. microinches for various rates of feed.

#### 5.5. Hardness Tests.

Brinell Hardness number = 402  
Meyer Strain Hardenability exponent 'n' = 2.18

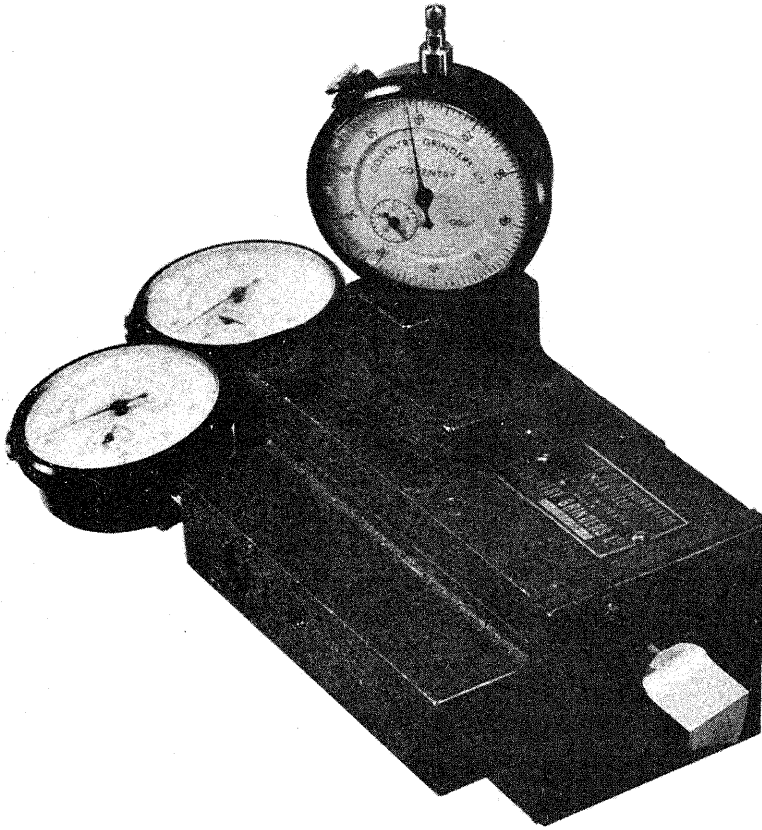

DYNAMOMETER

FIG. 1.

BY COURTESY OF COVENTRY  
GRINDERS LTD.,

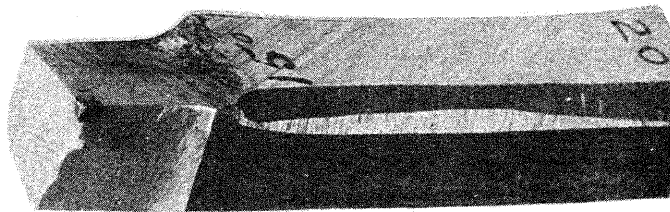
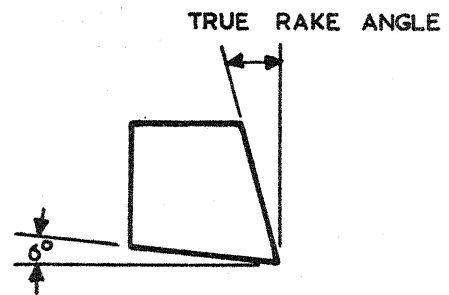
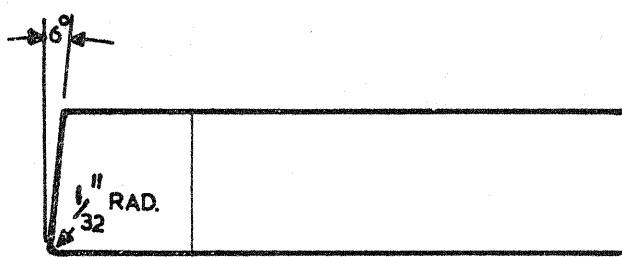

H.S.S. TOOL FOR USE IN DYNAMOMETER.

FIG. 2.

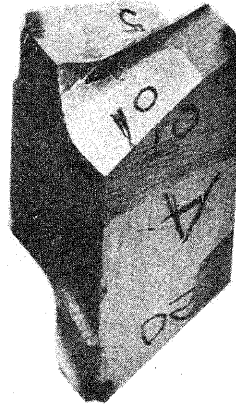
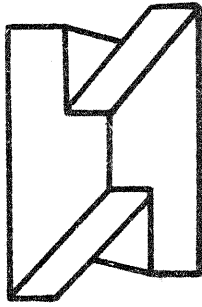

H.S.S. TOOL FOR LIFE TESTS. USED IN CLAMP TIP HOLDER.

FIG. 3.

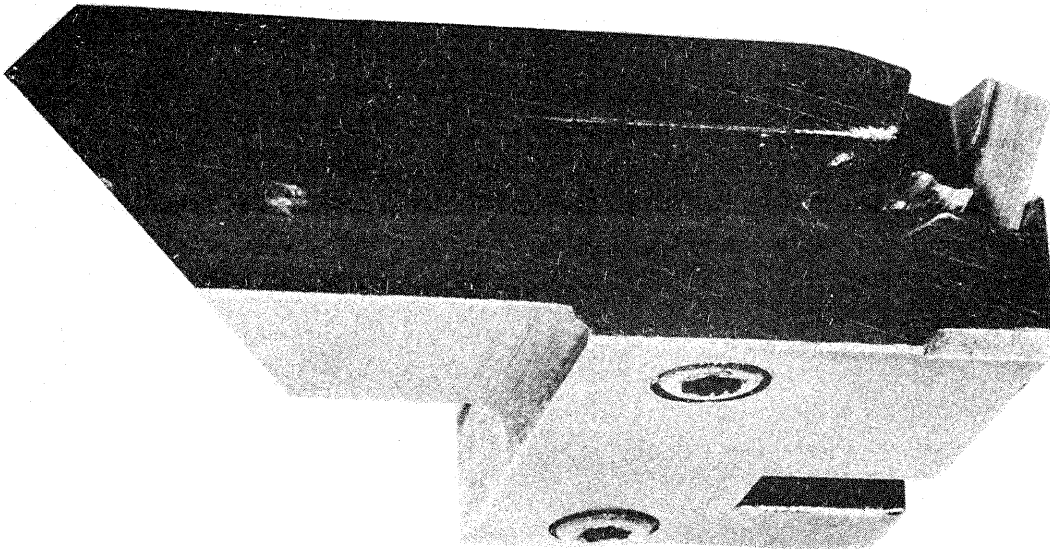

CLAMP TIP HOLDER

FIG. 4.

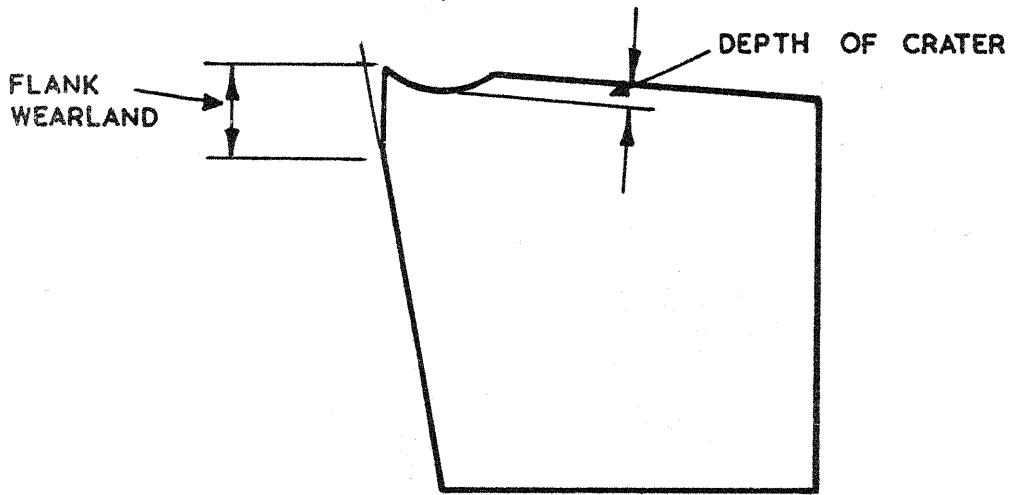

FIG. 5.

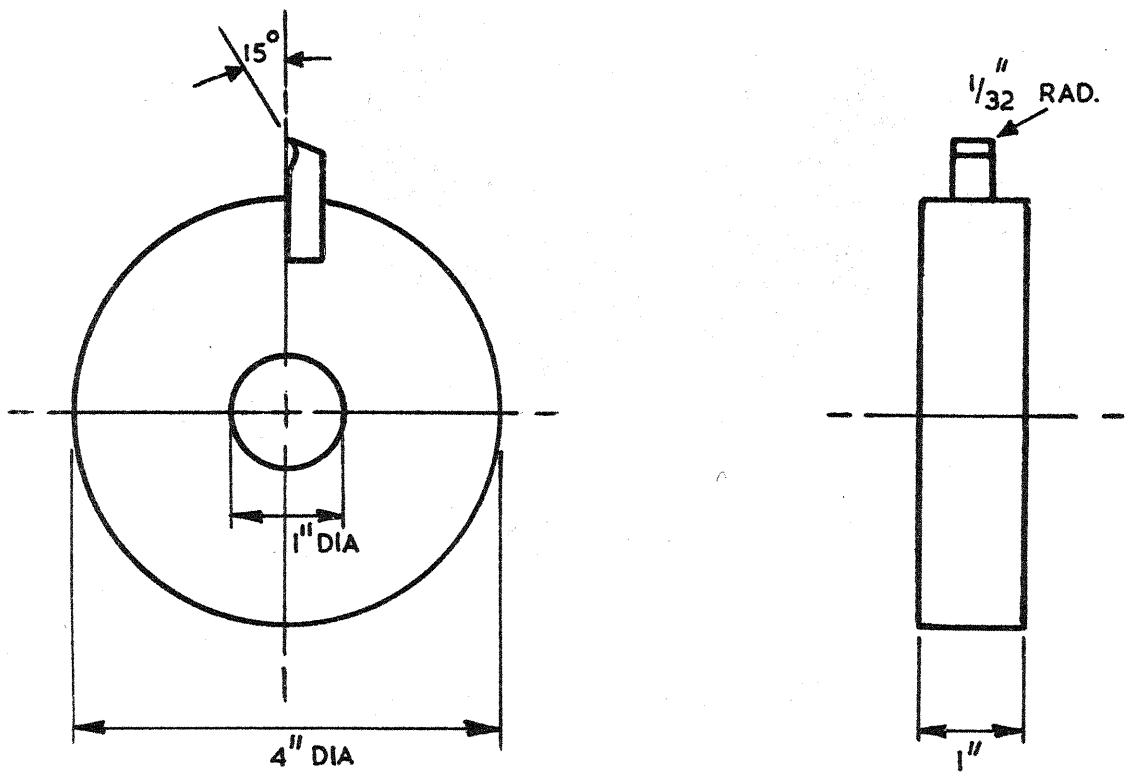
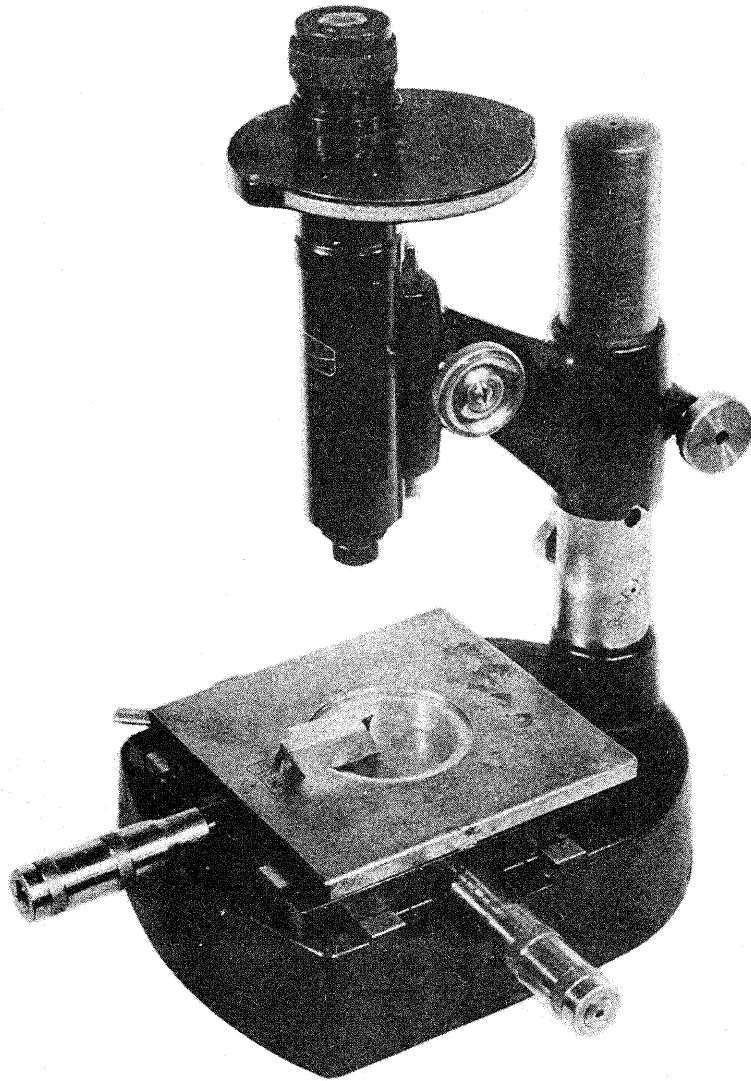
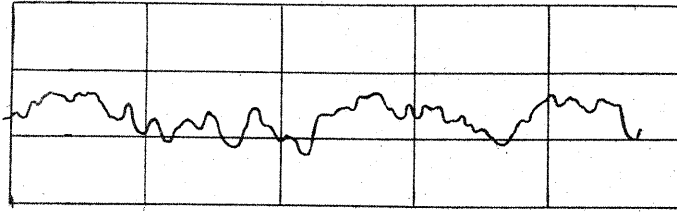

FIG. 6.



TOOLMAKERS MICROSCOPE

FIG. 7



D.T.D. 331 ·0025" FEED  
 $\frac{1}{32}$ " RAD ·050" DEPTH

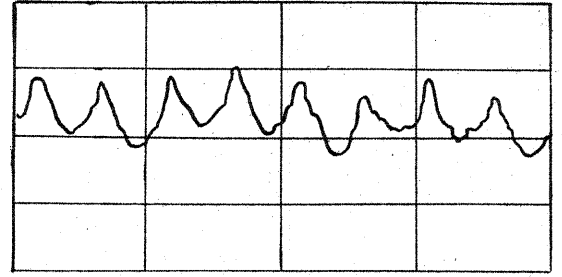

D.T.D. 331 ·005" FEED  
 $\frac{1}{32}$ " RAD ·050" DEPTH

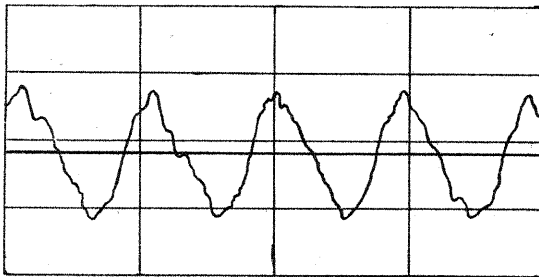

D.T.D. 331 ·010" FEED  
 $\frac{1}{32}$ " RAD ·050" DEPTH

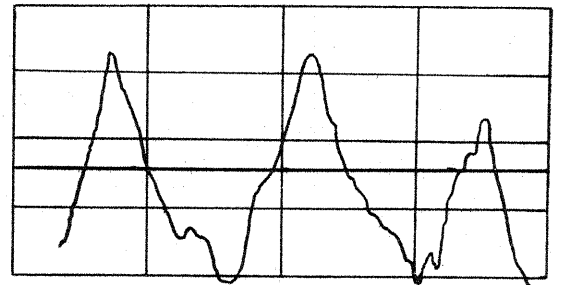

D.T.D. 331 ·015" FEED  
 $\frac{1}{32}$ " RAD ·050" DEPTH

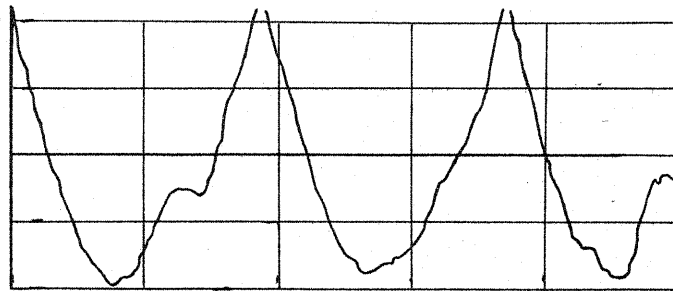

D.T.D. 331 ·020" FEED  
 $\frac{1}{32}$ " RAD ·050" DEPTH

**SURFACE FINISH DIAGRAMS**

**FIG. 8.**



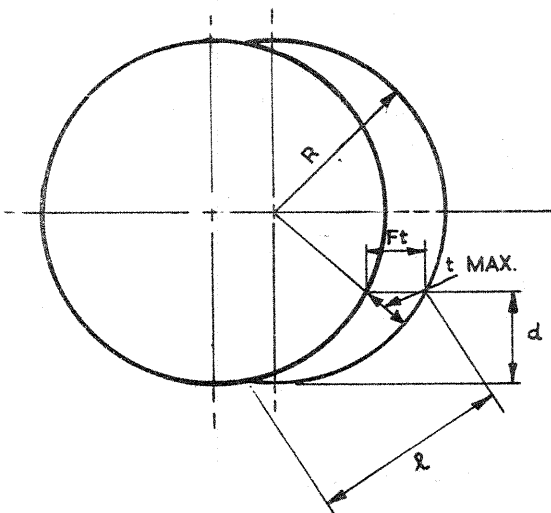
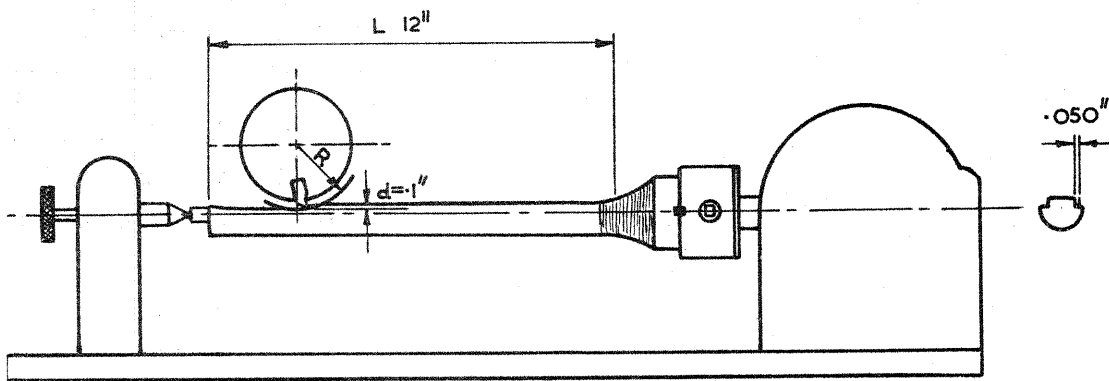
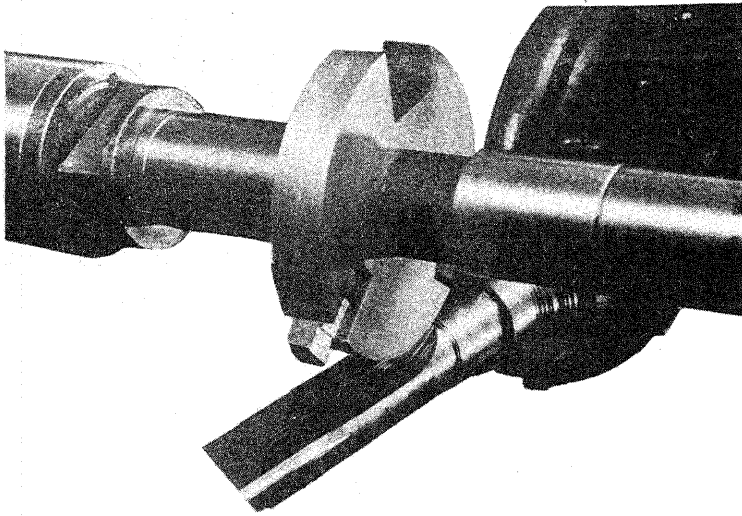

CHIP LENGTH  $l = \frac{\pi}{180} R \cos^{-1} \left( \frac{R-d}{R} \right) + \frac{Fr}{2\pi R} \sqrt{2Rd-d^2}$

MAXIMUM DEFORMED CHIP THICKNESS.

$$t \text{ MAX.} = Ft \sqrt{\frac{d(2R-d)}{(R+r)^2 - 2rd}}$$

WHERE  $Fr = \text{FEED / REV.}$

$$r = \frac{Fr}{2\pi}$$

$Ft = \text{FEED / TOOTH}$

HORIZONTAL MILLER.

FIG. 9.

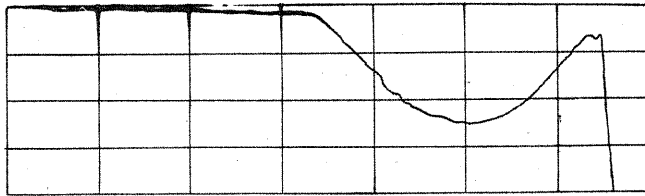

D.T.D. 331.  $.0011''$  FEED.  
 $\frac{1}{32}''$  RAD.  $.050''$  DEPTH.

TALYSURF RECORD OF CRATER.

FIG. 10.

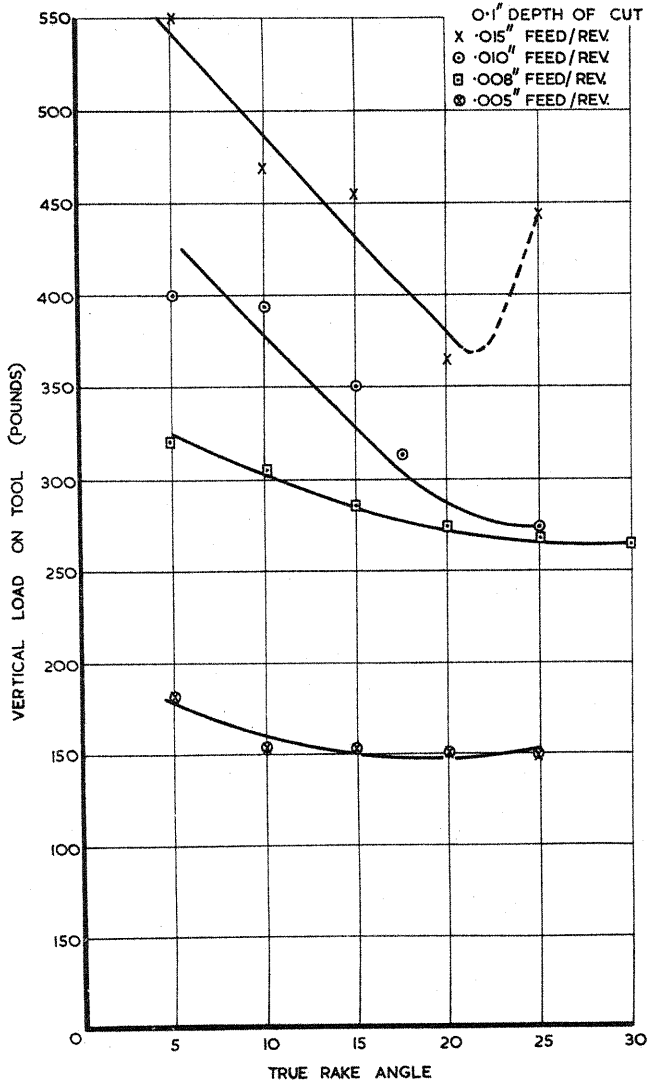

VERTICAL LOAD  $V_s$  TRUE RAKE ANGLE.  
 MATERIAL D.T.D. 331.

FIG. 11.

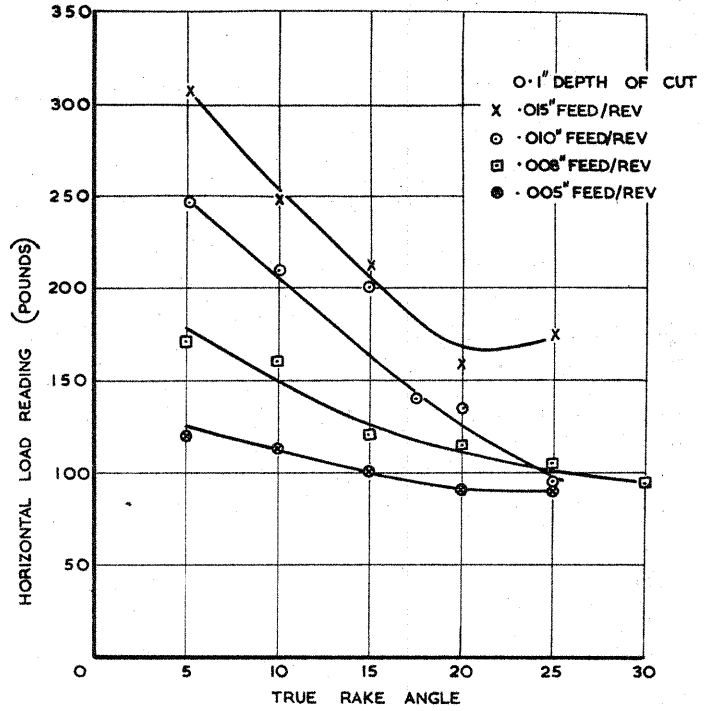

HORIZONTAL LOAD  $V_s$  TRUE RAKE ANGLE.  
 MATERIAL D.T.D. 331.

FIG. 12.

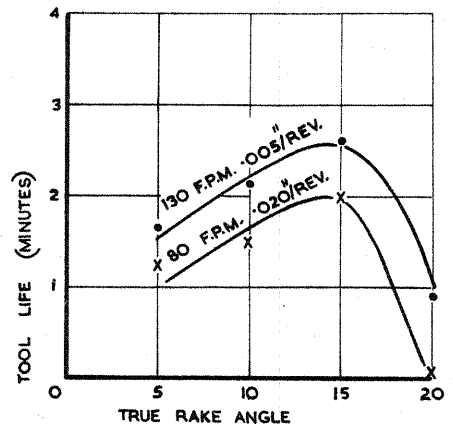

TOOL LIFE TESTS FOR TRUE RAKE ANGLE

FIG. 13.

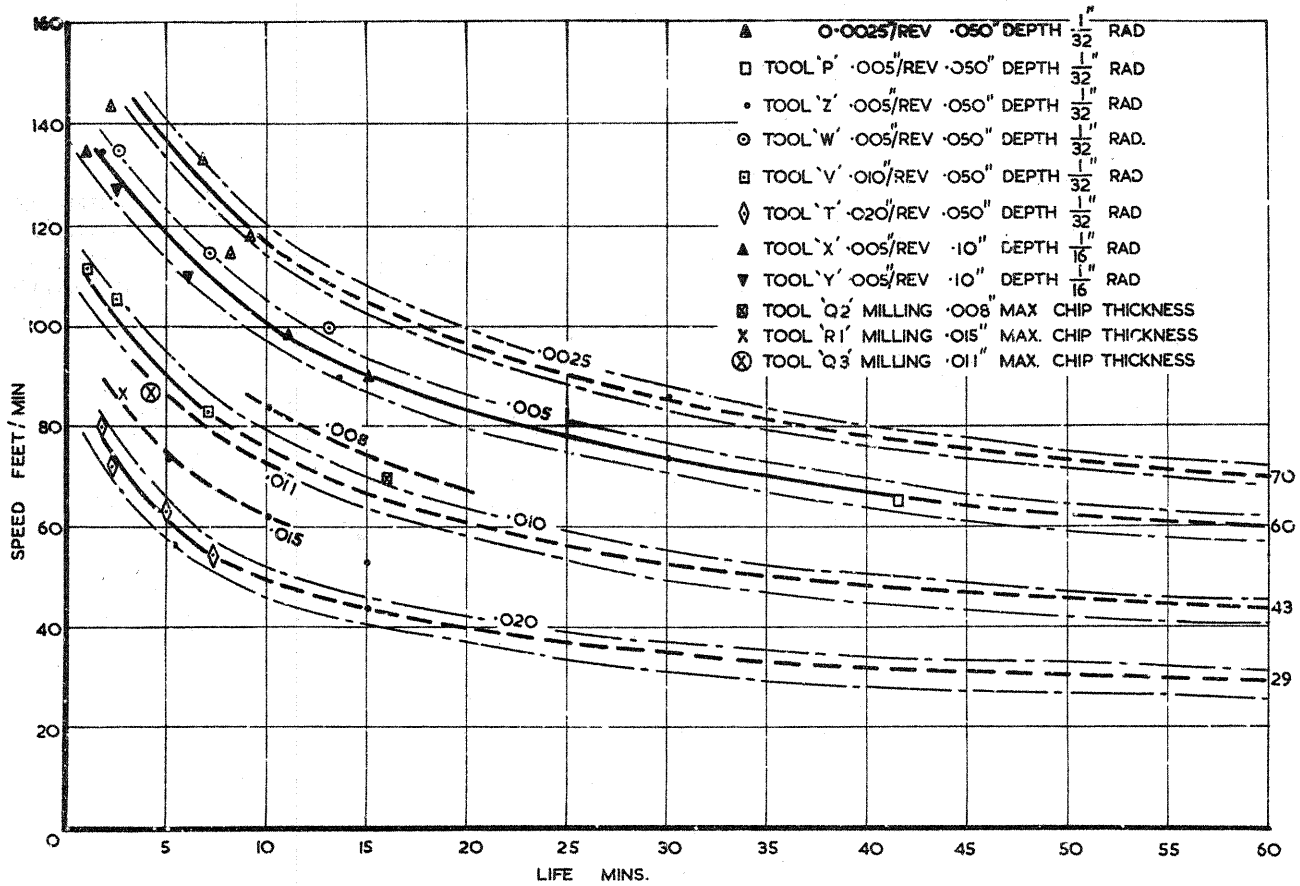

D.T.D. 331. TOOL LIFE CURVES SPEED/LIFE (MINS)

FIG. 14.

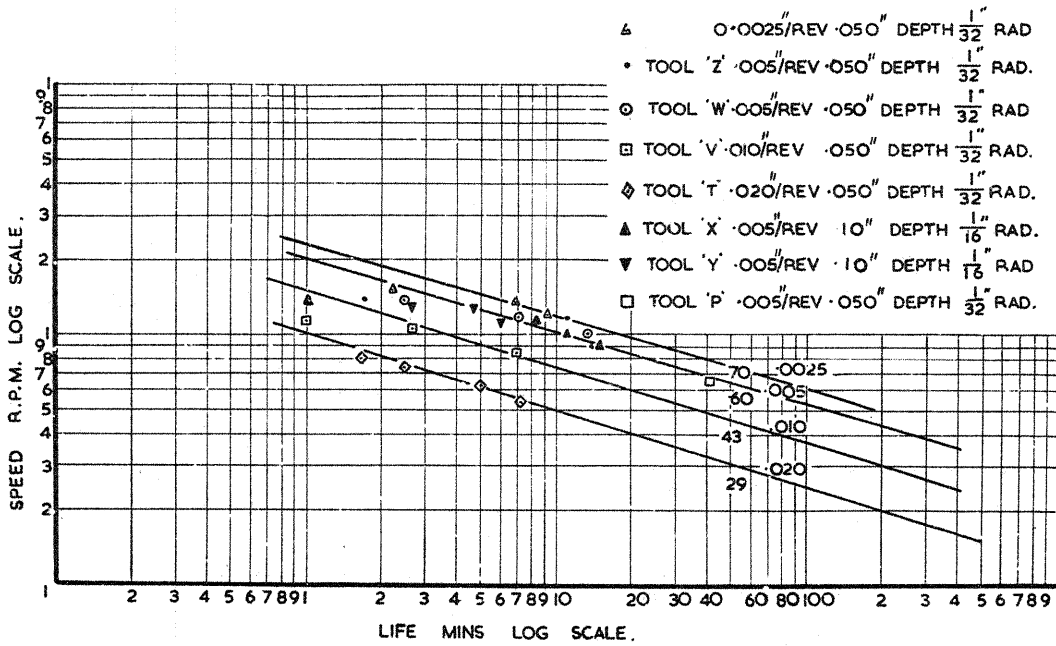
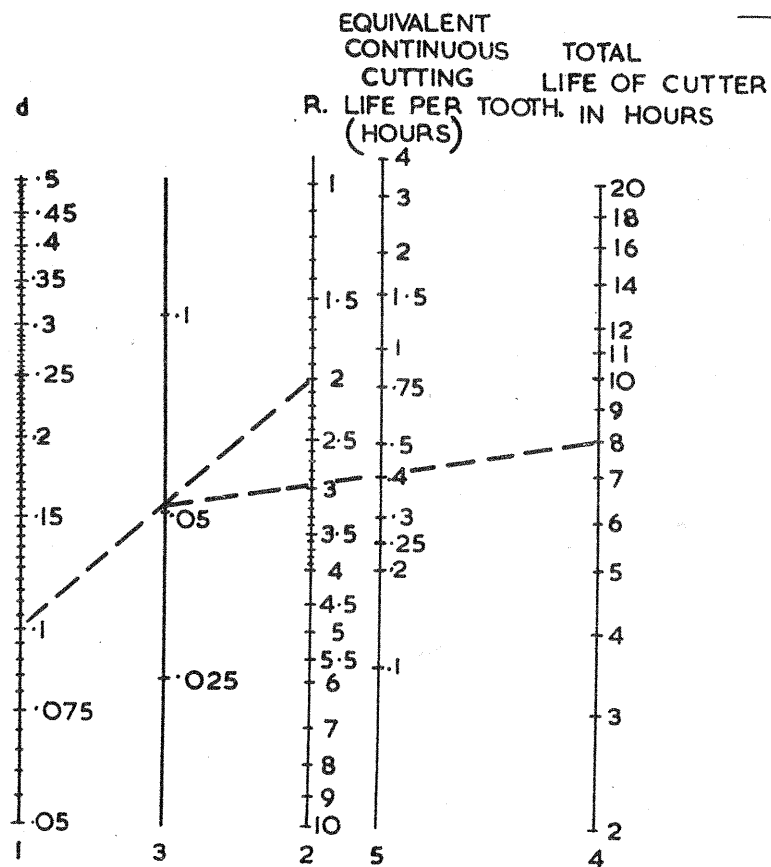
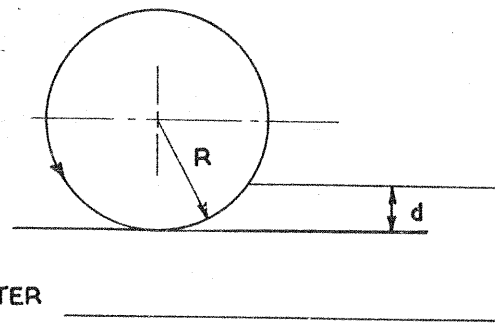

FIG. 15.



**PROCEDURE**

1. SELECT DEPTH OF CUT 'd' ON LINE (1)
2. JOIN WITH RADIUS OF CUTTER 'R' ON LINE (2)
3. MARK INTERSECTION POINT ON LINE (3)
4. JOIN INTERSECTION POINT WITH TOTAL LIFE SELECTED FOR CUTTER ON LINE (4)
5. READ OFF INTERSECTION POINT ON LINE (5)

TO DETERMINE EQUIVALENT CONTINUOUS CUTTING TIME PER. TOOTH.

FIG. 19.

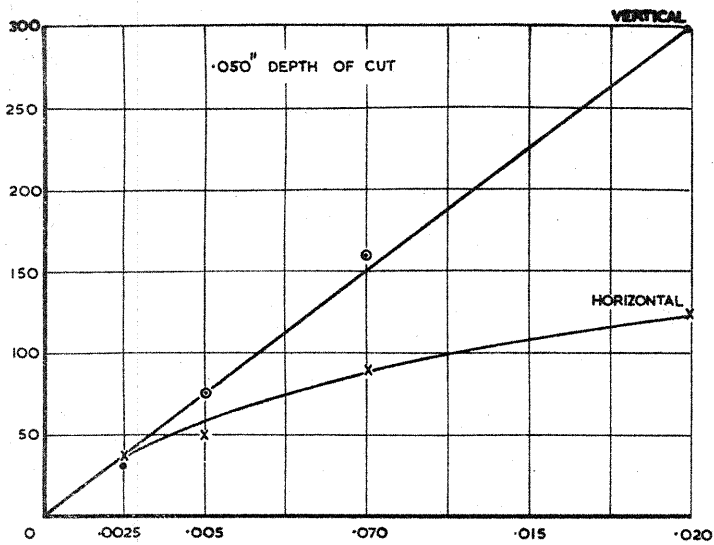

CUTTING FORCES  $V_s$  FEED RATE  
D.T.D. 331.

FIG. 16.

SPEED FOR A GIVEN TOOL LIFE  
AT VARIOUS RATES OF FEED.

FIG. 17.

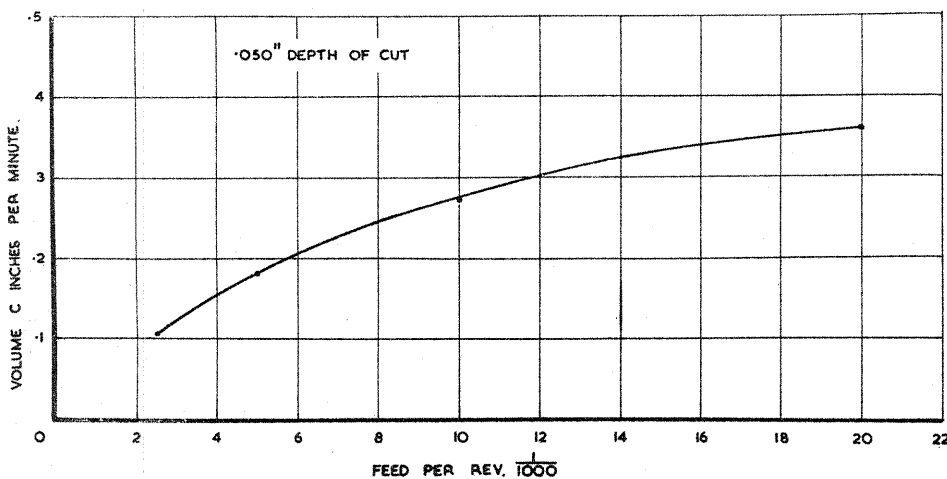
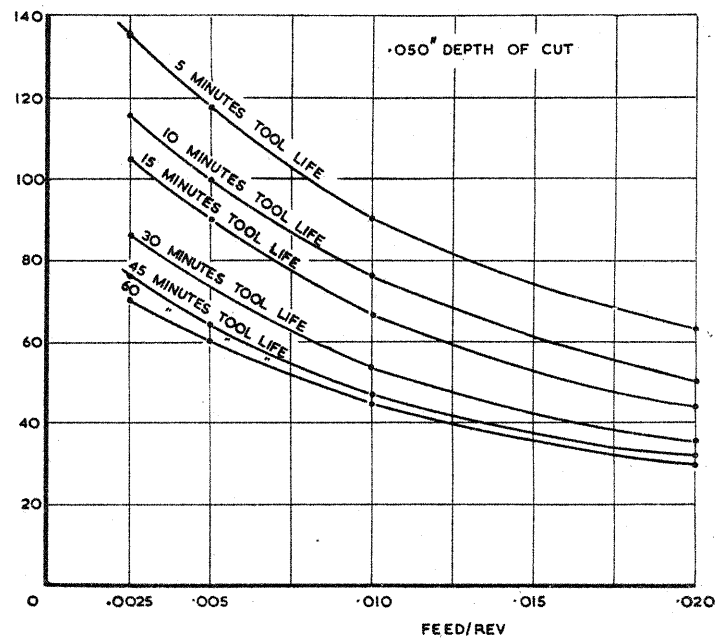

RATE OF METAL REMOVED FOR  
1 HOUR TOOL LIFE  
AT VARIOUS FEED RATES.

FIG. 18.

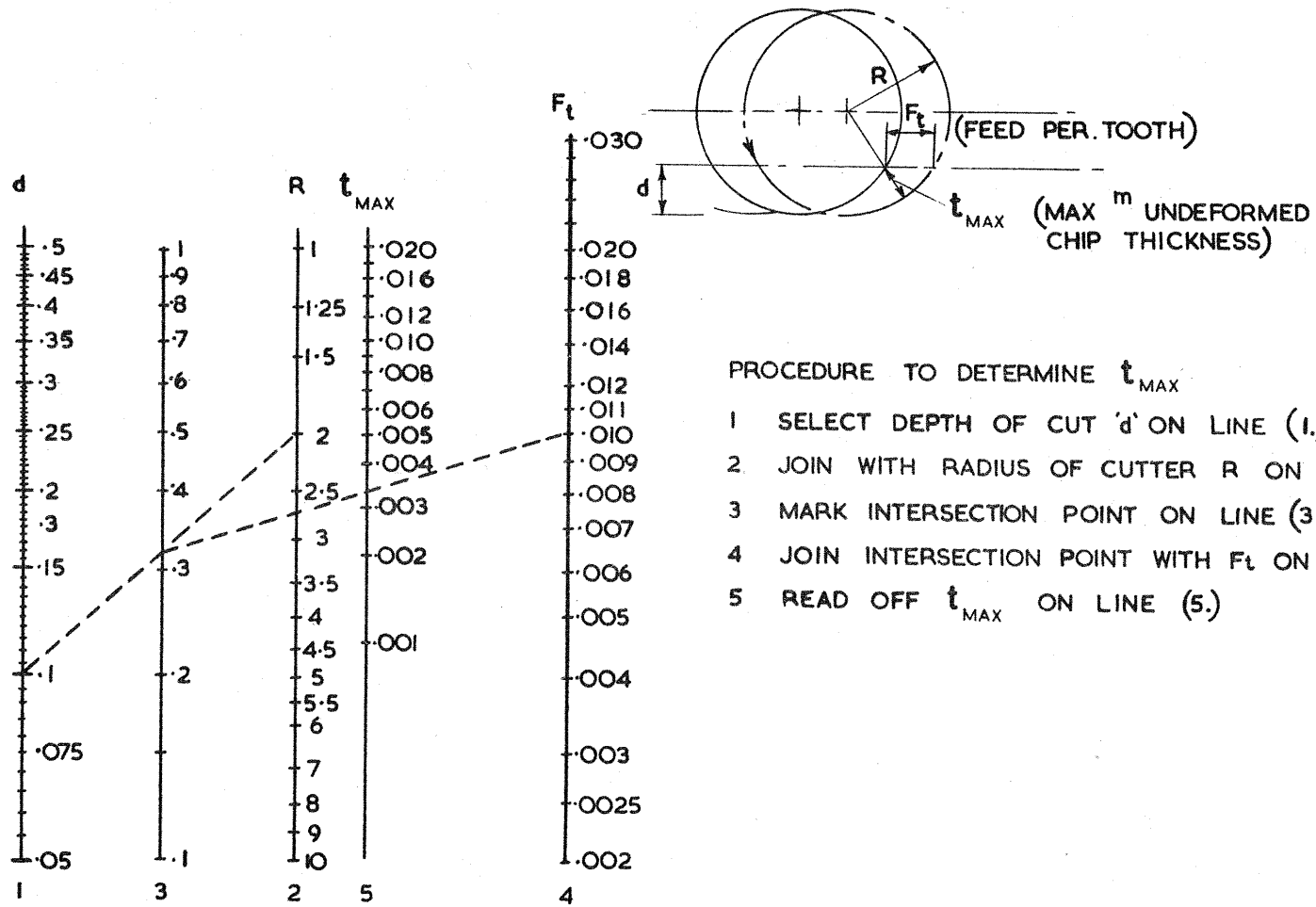

TO DETERMINE  $t_{MAX}$  (MAXIMUM UNDEFORMED CHIP THICKNESS.)

FIG. 20.