

# A novel accelerometer based feedback concept for improving machine dynamic performance

Jonathan Abir\* Paul Morantz\* Stefano Longo\*\* Paul Shore\*\*\*

\*Precision Engineering Institute, Cranfield University, Cranfield, MK43 0AL, UK, (j.h.abir@cranfield.ac.uk)

\*\*Centre for Automotive Engineering and Technology, Cranfield University, Cranfield, MK43 0AL, UK

\*\*\* National Physical Laboratory, Teddington, TW11 0LW, UK

---

**Abstract:** Small size ultra-precision Computer Numerical Control (CNC) machines require high dynamic performance. Flexible frame phenomena can limit the machine dynamic performance, particularly in small size machines. A novel accelerometer based feedback concept for improving machine dynamic performance was developed and realised, a virtual metrology frame. It expands the limited techniques for improving dynamic performance of a small size machine by measuring the flexible frame displacement, and feeding it into the controller. The concept was implemented in a simplified linear motion system, and showed a 12dB reduction in the magnitude of the first resonance in the plant frequency response function. This allowed improving the servo bandwidth by 58% based on a PID controller. A new technique for real-time dynamic displacement measurements using accelerometer was developed. It shows a low sensor noise  $\sigma < 30$  nm; thus, accelerometers are used as a displacement sensor in a control system.

**Keywords:** Accelerometers, CNC, digital filter, flexible frame, noise, ultra-precision, virtual metrology frame.

---

## 1. INTRODUCTION

In recent decades, numerous research efforts to develop machine tools with positioning performances at the nanometre level or better have been undertaken (Eijk 2008). Achieving such performance creates challenges for the metrology systems (sensors systems), with semiconductor patterning and inspection machines setting these high demands. Most breakthroughs have been achieved by separating metrology from the moving elements.

Many consumer products have seen significant miniaturization, especially in the IT industry, which brings higher demands for ultra-precision manufacturing capabilities. In contrast, many ultra-precision production machines have not seen a significant size reduction although numerous research efforts have been made. An ultra-precision production machine requires high machine accuracy, low motion errors, and high damping or dynamic stiffness. The existing solution for these requirements, as were developed in the semiconductor industry, is often antagonistic to the compact size constraint.

The  $\mu 4$  is a small size Computer Numerical Control (CNC) machine with 6 motion axes (Shore et al. 2013). It was developed by Cranfield University and Loxham Precision. Its specification in terms of machining accuracy was set around feature tolerance capability of  $< 1$   $\mu\text{m}$  and form accuracy of  $< 0.1$   $\mu\text{m}$ , which requires position accuracy in the nanometre scale and servo bandwidth of  $> 50$  Hz.

There are four important dynamic effects which influence machine dynamics (Coelingh et al. 2002): actuator flexibility,

guiding system flexibility, flexible frame, and backlash and friction. In a direct drive system with air-bearings the backlash and friction effect is negligible, even though there is (a small value of) friction due to cables. Actuator flexibility occurs when there is compliance between the motor and the load, typically where there is a gear in the system. Guiding system flexibility is a dynamic phenomenon where there is a limited stiffness of the guiding system combined with a driving force applied not at the centre of gravity. Flexible frame occur when the reaction forces effect on the machine dynamic, due to servo driving forces, are not negligible. It stimulates the machine frame resonances due to low stiffness of the frame.

A small size machine, equipped with high stiffness air-bearings, was identified as having flexible frame phenomena (Abir, Morantz, et al. 2015). Thus, the limiting dynamic effect to the machine performance is flexible frame, and not guiding system flexibility.

This article presents an accelerometer based feedback concept, a virtual metrology frame, allowing high-end metrology system consistent with the compact size constraint. The developed concept was demonstrated on a simplified linear motion system; a module of a small size CNC machine -  $\mu 4$ . In Section 2, various concepts of machine frame are introduced, and the effect of reaction force on a machine performance is analysed. In Section 3, the virtual metrology frame concept is presented. In Section 4, the acceleration based dynamic displacement measurement technique is described. The experimental setup and experimental results

are presented in Section 5 and Section 6 respectively. Finally, on Section 7 the paper is concluded.

## 2. MACHINE FRAME

A machine frame has two main functions (Soemers 2011): transfer of forces and position reference. Acceleration forces to the floor and process forces between the tool and fixture are transferred via the machine frame. The geometrical accuracy of the machine is maintained using the frame as a position reference to machine sub-systems.

In a servo system, a force  $F$  is applied to achieve the required position  $X$  of the carriage relative to the frame. There are three main concepts meeting the two required functions (Fig. 1). In the traditional concept (a), one frame structure is used for both functions. Reaction of the servo forces can excite the machine frame which will affect its performance. Thus, two concepts can be realised: Balancing Mass (BM) and metrology frame. The balancing mass compensates for the servo forces (b). Metrology frame is realised by separating the two functions, and having two frames – force frame and an unstressed metrology frame. The BM and metrology frame concepts can be combined to achieve superior performance (d), which is implemented in semiconductor lithography tools (Butler 2011). The metrology frame has its own vibration isolation system to prevent floor vibrations and servo reaction forces. However, the implementation of concepts other than the traditional one in a small size machine is difficult.

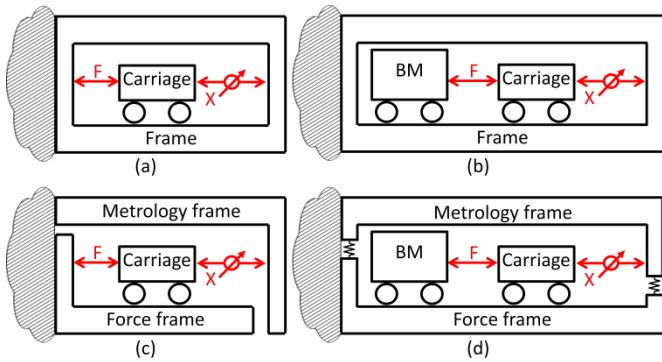

Fig. 1. Machine frame concepts. Traditional (a), balancing mass (b), metrology frame (c), and combined concept (d).

Based on the traditional design, the effect of reaction force on the machine performance can be analysed. Consider a linear direct drive machine with limited mass and stiffness (Fig. 2). There are two possible Transfer Functions (TFs) for the system depending on the reference system used to measure carriage position (Rankers & van Eijk 1994):  $TF_{fw}$  (1) the carriage position relative to a “fixed world”, and  $TF_c$  (2) the carriage position relative to the machine frame. The TFs are given below.

$$TF_{fw}(s) = \frac{x_{fw}(s)}{F(s)} = \frac{1}{m_c s^2} \quad (1)$$

$$TF_c(s) = \frac{x(s)}{F(s)} = \frac{1}{m_c s^2} + \frac{1}{m_f s^2 + k_f} \quad (2)$$

$TF_{fw}$  is an “ideal” TF, while  $TF_c$  is the practical TF which can be observed in any system.

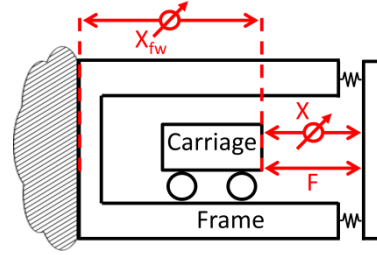

Fig. 2. Machine with linear direct drive and limited frame stiffness.

The  $TF_c$  consist of two modes: carriage rigid body mode and flexible frame mode. In the  $TF_{fw}$ , there is only carriage rigid body mode. In case of infinite frame stiffness (or mass) or in the case of separate metrology system, the flexible frame mode is negligible and  $TF_c \approx TF_{fw}$ . The Bode diagram of the TFs is shown in Fig. 3. The  $TF_{fw}$  is a double integrator type while  $TF_c$  is Antiresonance-Resonance (AR) type.

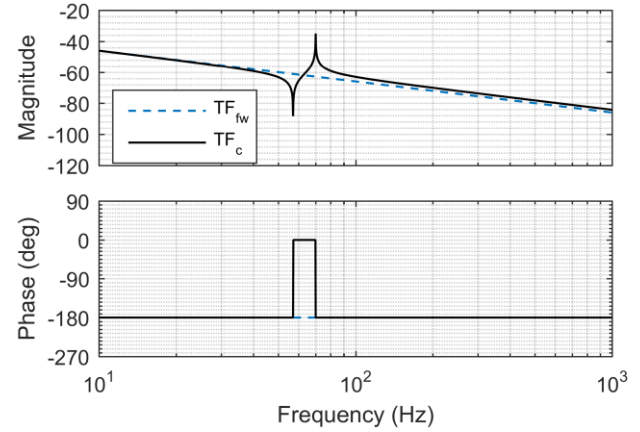

Fig. 3. Theoretical plant transfer function of a direct drive system with limited frame stiffness.

The dynamic properties of the machine are directly affected by the stiffness of the frame, and its reference system (Abir et al. 2016). Thus, by having an unstressed metrology frame the machine TF is as if it is  $TF_{fw}$ . Hence, superior dynamic capabilities can be achieved. Thus, a novel concept is required for allowing small size machine the capability of metrology frame without conflicting with its size constraint.

## 3. VIRTUAL METROLOGY FRAME

The *Virtual Metrology Frame* (VMF) concept solves the problem of the antagonistic requirements of small size machine and a metrology frame. The concept does not require the need of physical components associated with metrology frame, while the expected performance as if the machine has a separate metrology frame. The concept is realised (Fig. 4a) by distinguishing between the carriage position in respect to the stressed frame  $X_c$  and the frame displacement due to flexible modes  $X_f$ . Thus, unperturbed

position signal  $X_{vmf}$  can be obtained in the presence of frame flexible modes.

A typical control structure can be applied using the VMF (Fig. 4b). A reference position signal  $X_{set}$  is fed into the controller C, and its output is a control signal  $u$ . The plant P is the system to be controlled, it has input  $u$ , and output  $X_c$ . The difference to the control structure is that there is a second output to the plant  $X_f$ , the frame displacement, which is then fused with  $X_c$  inside the controller. Thus, the controlled signal is the sum of the position measurement signals  $X_{vmf}$ .

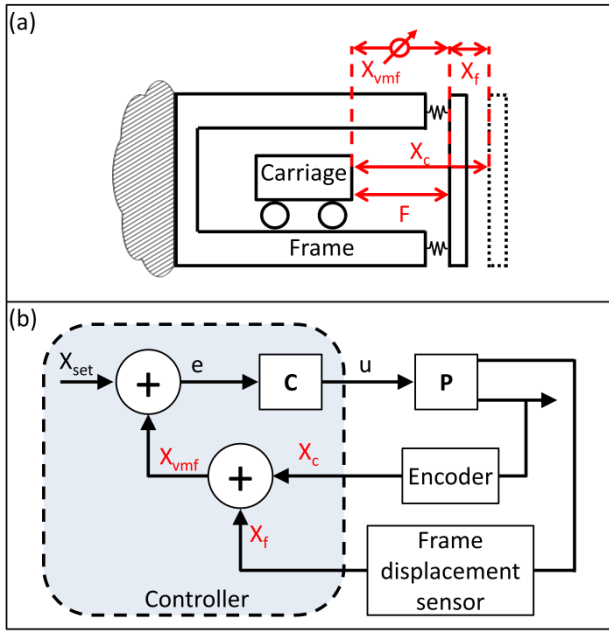

Fig. 4. Virtual metrology frame concept. Positioning concept (a), control concept (b).

The novelty of the VMF concept relies on real-time measurement technique of the frame displacement. Common techniques for precision displacement sensors require a fixed reference system, second frame, which is not feasible. However, using accelerometers for measuring the frame displacement offers a superior solution. The accelerometer measures the acceleration of a point without a fixed reference system. Using double integration, frame displacement can be obtained from the acceleration signal; thus, frame displacement can be estimated.

#### 4. ACCELERATION BASED DYNAMIC DISPLACEMENT MEASUREMENT TECHNIQUE

An accelerometer can be regarded as a single-degree-of-freedom (SDOF) mechanical system, with a simple mass, spring, and damper (Levinzon 2015). Its output signal can be represented (Zhu & Lamarche 2007):

$$a(t) = k_a \ddot{x}(t) + w(t) + w_0 \quad (3)$$

where  $k_a$  is the accelerometer gain,  $\ddot{x}(t)$  is the acceleration acting on the accelerometer,  $w(t)$  is the noise and disturbance effect, and  $w_0$  is the 0g-offset.

Double integration of a signal is a straightforward task. However, integrating noise leads to an output that has a root mean square value that increases with integration time (Thong et al. 2004). This can be a problem even in the absence of any motion of the accelerometer due to the 0g-offset.

Real-time implementation of acceleration based displacement measurement in a control system has two main conflicting requirements: low phase delay and low sensor noise. Thus, it is rarely reported (Celik et al. 2013), especially for long term (>10 s) and accurate (<0.1 $\mu$ m) measurements (Spiewak et al. 2013). Due to the low sensor noise requirements, Integrated Electronics PiezoElectric (IEPE) accelerometers are used. It offers low noise, wide dynamic bandwidth, and high sensitivity (Levinzon 2015).

A heave filter was chosen as the displacement estimator (Godhaven 1998). It is a combination of a High Pass Filter (HPF), and double integrator. A heave filter was used for estimating the heave position of a ship due to sea waves (Richter et al. 2014), and for compensating the structural vibration in large telescopes (Keck 2014). However, since minimal phase delay is required a pole-zero placement filter was added to correct phase delay as if the estimator is an ideal double integrator (4); however, the magnitude was influenced.

$$H = \frac{s^2}{(s^2 + 2\zeta\omega_c + \omega_c^2)^2} \cdot K \frac{s-z}{s-p} \quad (4)$$

where  $s$  is the Laplace variable,  $\zeta$  the damping coefficient, and  $\omega_c$  the filter cut-off frequency. The pole-zero placement,  $p$  and  $z$  respectively, and  $K$  the gain parameter.

The estimator was constrained to measure dynamic displacement of the machine frame that occurs at flexible resonances frequencies (>60Hz); thus, the HPF removes low frequency noise (<60Hz) which allows dynamic displacement estimation in the nanometre range.

A multi-objective genetic algorithm (Mathworks 2015) was used to optimize the estimator. There are various optimization techniques which can be used; however genetic algorithm was shown to be suitable for complex mechatronics problems (Van Brussel et al. 2001) and for multi-objectives problems (Coello et al. 2007). The optimization problem can be formally defined as: find the vector  $\vec{x} = [\vec{x}_1, \vec{x}_2, \dots, \vec{x}_n]^T$ , which satisfies  $n$  constrains

$$g_i(\vec{x}) \geq 0 \quad i = 1, \dots, n, \quad (5)$$

and optimize the vector function

$$\vec{J}(\vec{x}) = [\vec{J}_\sigma(\vec{x}), \vec{J}_M(\vec{x}), \vec{J}_P(\vec{x})]^T, \quad (6)$$

where  $\vec{x}$  is the estimator parameters vector that simultaneously minimizes the three error functions: displacement noise error function  $J_\sigma$ , magnitude error function  $J_M$ , and phase error function  $J_P$ .

The goals for the noise and phase errors were set due to system requirements. The displacement noise level is required to be comparable to the linear encoder noise (7), and the phase error is required to be smaller than the servo update rate (8). The magnitude error was set empirically (9).

$$J_{\sigma} < 30nm, \quad (7)$$

$$J_p < 62.5\mu s, \quad (8)$$

$$J_M < 2.5dB. \quad (9)$$

The frame displacement sensor (Fig. 4b) was realised using a real-time target machine (Speedgoat). It allows acquisition of the acceleration signal, and output of the estimated displacement signal. The signal processing algorithm, an optimised heave filter, was implemented in the target machine using Matlab/Simulink.

## 5. EXPERIMENTAL SETUP

A simplified linear motion system (Abir, Shore, et al. 2015) was used to validate the developed concept. It represents one of the  $\mu 4$  machine motion modules, and it has a flexible frame dynamic effect. The linear motion system consists of (Fig. 5): frame, air bearings and guideways, linear motor, encoder and carriage.

A software-based machine controller (Aerotech A3200) was used to control the motion system with a linear digital amplifier (Aerotech Ndrive ML). The digital servo amplifier has a servo loop update rate of 8 kHz, and a Proportional-Integral-Derivative (PID) digital control loop.

The VMF concept was realised by connecting the frame displacement sensor output to the linear motion system controller. In the controller, the frame displacement signal,  $X_f$ , and the encoder signal,  $X_c$ , were fused at the servo update rate, while the update rate of the target machine was 54 kHz.

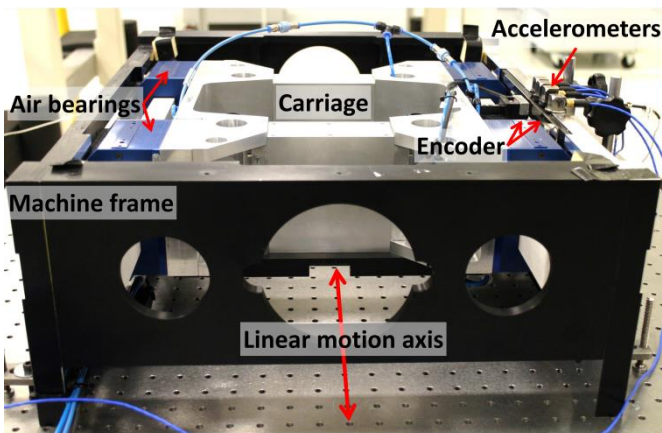

Fig. 5. Simplified linear motion system.

## 6. RESULTS

This section shows the experimental results validating the acceleration based dynamic displacement measurement technique, and the VMF concept.

### 6.1 Validation of the acceleration based dynamic displacement measurement technique

Validating the measurement technique was made by long term measurement, and by comparing the estimated displacement with laser interferometer measurement.

The long term measurement was made by mounting four tri-axial accelerometers (PCB 356A025) to a vibration isolation table, and acquiring the signal at 54 kHz for 600 seconds. The measured displacement noise was  $\sigma = 27.6 \pm 2.3 nm$ , which meets the requirement (7). Fig. 6 shows the estimated displacement at 0g-motion, i.e. the displacement noise, of one typical accelerometer.

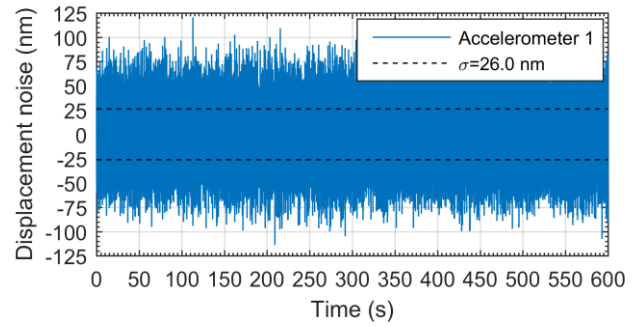

Fig. 6. Frame displacement sensor long term noise measurement.

Laser interferometer (Renishaw ML10 Gold Standard) was used to validate the estimated displacement. The laser light is split into two paths by a beam splitter, one that is reflected by a “dynamic” retroreflector and another reflected by a “stationary” retroreflector. The dynamic retroreflector was mounted to the machine frame, and an accelerometer mounted to the retroreflector (Fig. 7). The stationary retroreflector was fixed using an optics holder.

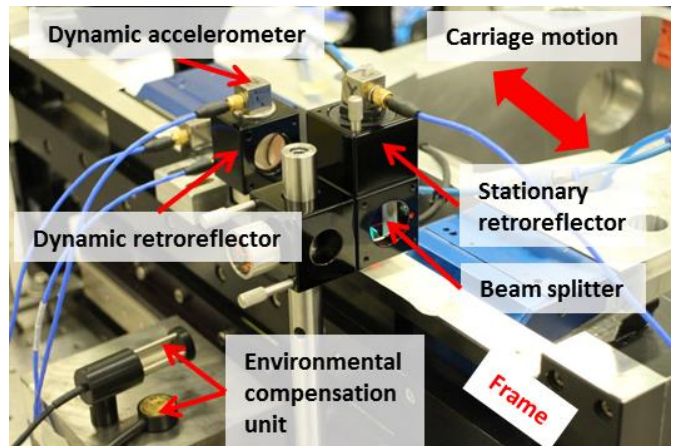

Fig. 7. Setup of the displacement validation experiment.

The frame was excited using an oscillating position command generated by the linear motion controller,  $X_{set} = A_i \sin(\omega_i \cdot t)$ , at various frequencies  $\omega_i$  and amplitudes  $A_i$ . The displacement amplitude measured by the laser interferometer and the acceleration based displacement

technique were calculated using a Fast Fourier Transform (Fig. 8). The discrepancy between the measurements meets the requirement (9).

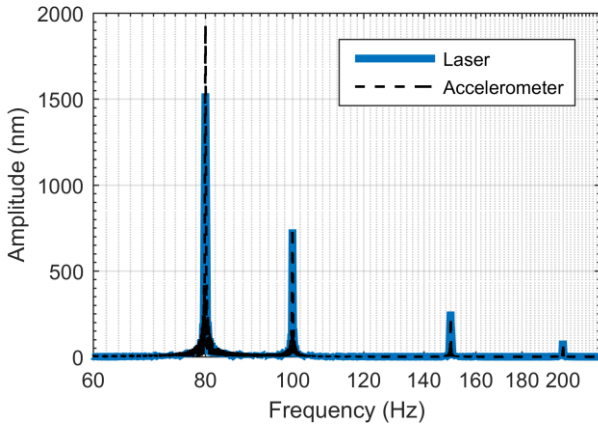

Fig. 8. Displacement amplitude measured by laser interferometer and the acceleration based displacement.

### 6.2 Validation of the virtual metrology frame concept

The VMF concept was realised by connecting the target machine output  $X_f$  to the machine controller. Fusing the two signals in the controller was setup to be at the maximal update rate – the servo update rate of 8 kHz. Then, using sinusoidal excitation the machine plant TF was measured. Comparison of the plant TF with and without the VMF is shown in Fig. 9. A significant magnitude reduction of 12dB in the frame resonance can be observed.

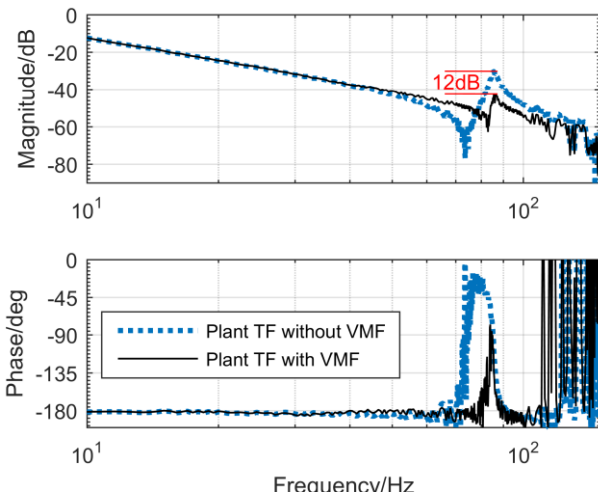

Fig. 9. Comparison of plant Transfer Function (TF) with and without the Virtual Metrology Frame (VMF) concept.

Based on the PID algorithm implemented in the controller, the servo bandwidth was improved by 58% (Fig. 10) due to the significant reduction in the frame resonance, while the overshoot was reduced, and the stability margin remains the same.

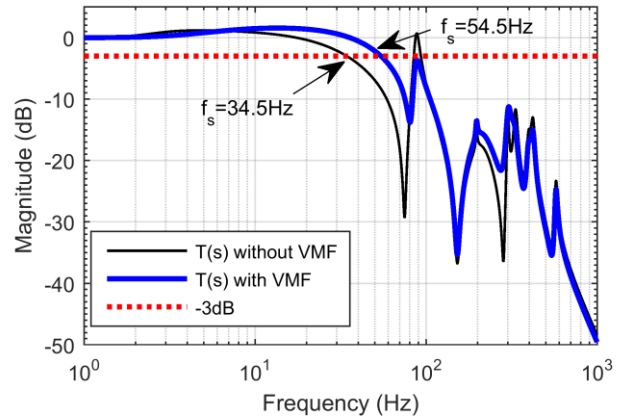

Fig. 10. Comparison of closed loop  $T(s)$  with and without the Virtual Metrology Frame (VMF) concept.  $f_s$  is the closed loop bandwidth.

## 7. CONCLUSIONS

The virtual metrology frame is a novel mechatronic concept for improving machine dynamic performance with a flexible frame. Thus, it offers an optimal solution of having high-end metrology system and small size constraint. The flexible frame resonance affecting the machine performance was reduced significantly, but not completely. The concept allows a significant improvement to the dynamic performance without affecting overshoot and stability margins.

In a control system, acceleration based displacement measurement is rarely used due to the practical problems of phase delay and noise removal. However, a new measurement technique was developed based on accelerometers. It allows significant noise reduction by measuring only in the machine frame resonances bandwidth. Thus, accelerometers can be used in a control system as a precision dynamic displacement sensor in the nanometre range.

Further research is being carried out by reducing the errors and increasing the bandwidth of the developed measurement technique. Furthermore, the improvement to the servo bandwidth is being assessed.

**ACKNOWLEDGMENTS:** This work was supported by the UK EPSRC under grant EP/I033491/1 and the centre for innovative manufacturing in ultra-precision. J. Abir is grateful to the McKeown Precision Engineering and Nanotechnology foundation at Cranfield University, and B'nai B'rith Leo Baeck (London) for their financial support.

## REFERENCES

- Abir, J. et al., 2016. Feedback based technique for improving dynamic performance of a small size machine tool. In *ASPE Spring Topical Meeting on Precision Mechatronic System Design and Control*. pp. 58–61.
- Abir, J., Morantz, P. & Shore, P., 2015. Position errors due to structural flexible modes. In *Proceedings of the 15th international conference of the European society for precision engineering and nanotechnology*. pp. 219–

- Abir, J., Shore, P. & Morantz, P., 2015. Influence of temperature changes on a linear motion system. In *Lamdamap (Laser Metrology, Machine Tool, CMM & Robotic Performance) XI*. pp. 126–135.
- Van Brussel, H. et al., 2001. Towards a mechatronic compiler. *IEEE/ASME Transactions on Mechatronics*, 6(1), pp.90–105.
- Butler, H., 2011. Position control in lithographic equipment. *IEEE Control Systems Magazine*, 31(5), pp.28–47.
- Celik, O., Gilbert, H.B. & O'Malley, M.K., 2013. Dynamic displacement sensing, system identification, and control of a speaker-based tendon vibrator via accelerometers. *IEEE/ASME Transactions on Mechatronics*, 18(2), pp.812–817.
- Coelingh, E., De Vries, T.J. A & Koster, R., 2002. Assessment of mechatronic system performance at an early design stage. *IEEE/ASME Transactions on Mechatronics*, 7(3), pp.269–279.
- Coello, C.C., Lamont, G.B. & Veldhuizen, D.A. Van, 2007. *Evolutionary Algorithms for Solving Multi-Objective Problems*, Springer Science & Business Media.
- Eijk, J. Van, 2008. METROLOGY AND MOTION. In *Precision Mechanical Design and Mechatronics for Sub-50nm Semiconductor Equipment*. Berkeley, California: ASPE, pp. 3–5.
- Godhaven, J.-M., 1998. Adaptive tuning of heave filter in motion sensor. In *IEEE Oceanic Engineering Society. OCEANS'98. Conference Proceedings*. IEEE, pp. 174–178.
- Keck, A., 2014. Accelerometer-based online reconstruction of vibrations in extremely large telescopes. In *the International Federation of Automatic Control (IFAC) World Congress*. pp. 7467–7473.
- Levinzon, F., 2015. *Piezoelectric Accelerometers with Integral Electronics*, Springer.
- Mathworks, 2015. *Global optimization toolbox, User's guide Version 3*, Mathworks.
- Rankers, A.M. & Van Eijk, J., 1994. The influence of reaction forces on the behaviour of high performance motion systems. In *Proc. of the Second International Conference on Motion and Vibration Control, Yokohama*. pp. 711–716.
- Richter, M. et al., 2014. Real-Time Heave Motion Estimation Using Adaptive Filtering Techniques. In *the International Federation of Automatic Control (IFAC) World Congress*. pp. 10119–10125.
- Shore, P., Morantz, P. & Read, R., 2013. Design overview of the  $\mu 4$  Compact 6 axes ultra precision diamond machining centre. In *10th International Conference and Exhibition on Laser Metrology, Machine Tool, CMM & Robotic Performance*. euspen.
- Soemers, H., 2011. *Design Principles: For Precision Mechanisms*, T-Pointprint.
- Speedgoat, speedgoat performance real-time target machine. Available at: <https://www.speedgoat.ch/Products/Real-timetargetmachines-Performance/Default.aspx> [Accessed January 1, 2016].
- Spiewak, S., Zaiss, C. & Ludwick, S.J., 2013. High Accuracy, Low-Invasive Displacement Sensor (HALIDS). In *Proceedings of the ASME 2013 International Mechanical Engineering Congress and Exposition*. ASME, p. 77.
- Thong, Y.K. et al., 2004. Numerical double integration of acceleration measurements in noise. *Measurement: Journal of the International Measurement Confederation*, 36(1), pp.73–92.
- Zhu, W.-H. & Lamarche, T., 2007. Velocity estimation by using position and acceleration sensors. *Industrial Electronics, IEEE Transactions on*, 54(5), pp.2706–2715.