

COA/M/ASAE - 76

ST. NO. R 31075  
U.D.C.  
AITH.

ASAE Memo No. 76

ADVANCED SCHOOL OF AUTOMOBILE ENGINEERING  
CRANFIELD

A review of data analysis systems

- by -

G.D. Whitehead



R 31075



ASAE Memo No. 76

September, 1965

ADVANCED SCHOOL OF AUTOMOBILE ENGINEERING

A review of data analysis systems

- by -

G.D. Whitehead



S U M M A R Y

This review gives an appraisal of 8 Automatic Time history record analysis systems.

The appraisal indicates the analytical capabilities, analysis flexibility and the cost involved in performing the analysis.

It is suggested that in choosing such a system for an educational institution, some analysis speed and automation should be sacrificed for computational flexibility and operational adaptability.

The review does not indicate that a specific machine be considered, but rather that an analysis system be built from a number of manufacturing sources.

## Table of Contents

		<u>Page No.</u>
1.0	Introduction	1
	List of systems reviewed	2
1.1	Summary of main conclusions	3
	The choice of a system	5
2.0	Definition of the true mathematical functions for which measured estimates are desired	7
2.1	Mathematical functions for periodic data	7
2.2	Mathematical functions for weakly stationary random data	7
2.21	Simple statistics of random data	8
2.22	Description in the amplitude domain	8
2.23	Description in the time domain	9
2.24	Description in the frequency domain	9
2.3	Joint properties of a pair of weakly stationary random records	10
2.31	Joint description in the amplitude domain	10
2.32	Joint description in the time domain	11
2.33	Joint description in the frequency domain	11
2.4	Mathematical properties of stochastic processes	12
2.41	Statistical description of weakly stationary processes	12
2.411	Simple statistics of processes	13
2.412	Description of stochastic processes in the time domain	13
2.413	Description of stochastic processes in the amplitude domain	14
2.42	Joint properties of a pair of weakly stationary stochastic processes	14
2.421	Joint description of processes in : amplitude domain	14
2.422	: time domain	15
2.43	Statistical description of non-stationary stochastic processes	15
2.44	Description of weakly stationary and non- stationary stochastic process in frequency domain	17
2.441	- Weakly stationary processes	17
2.442	- Non-stationary processes	18
2.5	Input/Output relationships for constant parameter linear systems - weakly stationary excitation	19
2.51	- Frequency response function	19
2.52	- Transfer function	20
2.6	Motion/Force relationships for physical systems	21
3.0	Appraisal of the systems	22
3.1	Objectives of the systems	22

3.2	Separation and allocation of Man/Machine functions in the realisation of system objectives	24
3.3	Specification of the hardware	31
3.4	Design of the hardware	31
3.5	The man/machine interface	34
3.6	Job aids for the data analyst	36
3.7	System integration	36
3.8	System evaluation	37
3.81	Ad-Yu	37
3.82	Fenlow	37
3.83	Gulton	38
3.84	Honeywell	38
3.85	Noratom	39
3.86	Spectral Dynamics Corporation	40
3.87	Technical Measurement Corporation	40
3.88	Technical Products Company	40
4.0	Physical and Practical considerations in the measurement analysis of time history records	41
4.1	Periodic time history records	41
4.11	Measurement analysis accuracy	41
4.12	Measurement resolution	42
4.13	Length of time history record	42
4.14	Averaging time	42
4.15	Sweep on scan rate	42
4.16	Analysis time	43
4.2	Random time history records that are weakly stationary	43
4.21	Analysis accuracy	43
4.22	Amplitude domain	43
4.221	Statistical uncertainty in amplitude domain	44
4.222	Measurement resolution	45
4.223	Length of record	45
4.224	Averaging time	45
4.225	Scan rate	46
4.226	Analysis time	46
4.23	Time domain	46
4.24	Frequency domain	48
4.3	Description of a pair of random time history records	50
4.31	Amplitude domain	50
4.32	Time domain	51
4.33	Frequency domain	51
4.4	Discussion of considerations for processes and non-stationary data	52
	Appendix 1	
	Tables	
	Figures	

## 1.0 Introduction

This review gives an appraisal of a number of currently available statistical analysis systems.

The objects of the review were as follows:

1. To study the analytical capabilities of the systems in the light of defined mathematical functions.
2. To determine the degree of flexibility in computation.
3. To ascertain the means provided for the control of:

Measurement Resolution  
Statistical Uncertainty.

4. To determine the cost of performing an analysis in relation to the degree of automation and flexibility.
5. To draw some broad conclusions regarding the suitability of the system to the analysis of automobile dynamic data, and to provide guidelines for the specification of a subsequent system.

After defining the true mathematical functions (for which measured estimates are desired) in section 2, an appraisal of the system is given in section 3. The appraisal in section 3, is largely summarised in tables I and II. An analysis of the cost involved in the computation is given, where possible, in table III. This table shows what it would cost to perform the individual computations using the minimum amount of equipment. Table IV gives a breakdown of price in terms of the degree of automation, for systems which may be bought in functional 'building blocks'. It also indicates the functional capabilities of the machine at that price.

It is important in these analyses to be able to control the measurement resolution and the degree of statistical uncertainty in the measurements. In section 4, the meaning of these terms is explained in relation to the type of analysis envisaged. Table V gives a summary of these considerations. Table II which deals with the machine specifications has been stratified into those specification items which influence operation and performance and those which limit the measurement accuracy, resolution and statistical uncertainty. Table II therefore, if used in conjunction with table V indicates how well a system could meet the desired accuracies.

No attempt has been made to specify the system required by the A.S.A.E.

The systems under review are as follows:-

1. Ad Yu Automatic Analysis System type 1010.

Makers: Ad Yu Electronics INC.,  
249-259 Terhune Ave.,  
Passiac,  
New Jersey, U.S.A.

2. Fenlow Spectrum Analyser.

Makers: Fenlow Electronics Ltd.,  
Weybridge,  
Surrey, England.

3. Gulton Modular Spectrum Analysers

Type OR-WA/1  
OTP-1  
OF-3.

Makers: Gulton Industries,  
Ortholog Division,  
4054 Quaker Bridge Road,  
Trenton,  
New Jersey, U.S.A.

4. Honeywell Series 9300 A and B Spectrum Analyser and  
Honeywell Series 9410 Time delay Correlator.

Makers: Honeywell,  
Denver Division,  
4800 East Dry Creek Road,  
Denven,  
Colorado, U.S.A.

5. Noratom: Instrument for Statistical Analogue Computations.

Makers: Noratom AS.  
Holmenveien 20,  
Oslo 3, Norway.

6. S.D.C. 101 - 1002 Automatic Analysis Systems.

Makers: Spectral Dynamics Corporation of San Diego,  
8159 Engineer Road,  
San Diego  
California, U.S.A.

7. T.M.C. Computer of Average Transients.

Makers: Technical Measurement Corporation,  
Mnemotron Division,  
202 Mamoroneck Ave.,  
White Plains, New York, U.S.A.

## 8. TP.625 Wave Analyser Systems.

Makers: Technical Products Company,  
Instrument Division,  
6670 Lexington Ave.,  
Los Angeles 38,  
California, U.S.A.

Apart from the Fenlow Analyser (which was included to demonstrate our present analysis capabilities) the systems in this review were chosen for their suitability in the analysis of low frequency signals (below 60 c/s) and because they are multi purpose machines with a high degree of automation. The review is not claimed to be exhaustive, it leaves out a host of single purpose instruments such as statistical level counters, variable head displacement tape recorders, etc. The digital computer, of course, is capable of computing all of the defined mathematical functions. The areas of analysis best left to the digital computer are indicated in table 1.

To evaluate a system properly, its operation must first be learnt by the data analyst and the system then evaluated to see how well it achieves its stated objectives. In this review no such evaluation was possible, although a number of the machines have been seen in operation. It must therefore be stressed that the evaluation of these systems was largely carried out from sales literature and discussion with designers. The limitations of the review should therefore be appreciated.

### 1.1 Summary of main conclusions

Of the 8 systems reviewed the TPC system could compute the most functions, followed by the Honeywell and Gulston systems.

The Honeywell series 9300B system was the system capable of the highest degree of statistical accuracy. It was also the fastest analyser in the frequency domain and the simplest to operate. The Honeywell system was the one most recently put on the market.

The most flexible system in terms of computation and adaptation was the TPC 625 Wave Analyser.

Three of the manufacturers in this review offer a full motion/force analysis system. No specification or price details, unfortunately, were available at the time of review for the TPC system. Of the remaining two the Ad Yu system is thought to be most accurate but is rather undeveloped as a power spectrum analyser. The Spectral Dynamics system was slightly less accurate than the Ad Yu, but more highly developed to perform other analyses such as power spectrum analysis.

Each of the systems reviewed here, could claim some unique features not found elsewhere. These are summarised below:

Ad Yu:

Heart of the Ad Yu system was a phase angle computer capable of  $\pm 1/4$  degree relative phase angle accuracy and  $\pm 1^\circ$  absolute accuracy.

Fenlow:

Capable of the highest degree of spectral resolution with a filter bandwidth of 0.06 c/s and frequency scan rate as low as  $9.05 \cdot 10^{-5}$  c/s/s.

Gulton:

Largest choice of filter bandwidths from 0.4 c/s - 500 c/s.  
Programming facility for: filter bandwidths, averaging time constants and frequency sweep periods. Frequency axis calibration marker.

Honeywell:

A unique automatic input voltage monitoring system (gain sensing) for switching the input amplifier gain and re-calibrating the output voltage.

A unique stepped mode of operation permitting the highest statistical accuracy and fast analysis.

Integrator controlled record length.  
Highest filter shape factor 10:1.

Noratom:

The only fully integrated system with its own 3 channel tape recorder/ reproducer having a speed up ratio of 1024:1 and time delay mechanism.

The only machine capable of analysing in all three domains.

Spectral Dynamics Corporation:

The provision of a tracking frequency multiplier which converts a periodic signal to a sine wave and frequency multiplies the sine wave in the range 0.1 - 150.

The provision of several plug in units for controlling the motion of a shaker.

Technical Measurement Corporation:

The only instrument capable of analysing an ensemble of records.

The only instrument capable of ON-LINE analyses.

Technical Products Company:

The only system to offer a fully operational range of functional units. The systems offer a unique amplitude probability analyser and multiplier/divider.



The choice of a system

In this the reviewer believes that some sacrifice in analysis speed and automation should be made for flexibility and adaptability of operation.

In industry where answers mean production, speed and accuracy would surely lead to the choice of the Honeywell 9300B system, for frequency analysis, the TMC C.A.T. for time analysis and the TPC. Probability Analyser for amplitude analysis.

In an educational institute of which this is one, if the machine is to fulfil the needs of teaching as well as research, a more flexible machine is needed where the effect of changing analysis parameters can be more readily demonstrated to students. This facility must not of course make analysis unreasonably time consuming.

Bearing in mind these suggestions, as well as cost, it is suggested that the following combination of systems be considered.

1. Technical Products system

Comprising: (See Table IV 3rd System)

- 1 - Probability Analyser
- 2 - Frequency Analysers
- 1 - Sweep Oscillator
- 1 - Multiplier
- 1 - Potentiometer
- 1 - XY Plotter

plus

Technical Measurement Corporation

Computer of Average transients

Price £12,370.

In this suggested system the Spectral Dynamics analyser and Sweep Oscillator may be substituted for the TPC versions. This decision would be based on the relative importance of the S.D.C. tracking frequency multiplier to the TPC range of plug-in detector units. The substitution would not substantially effect the price.

System 1 would allow single channel frequency analysis and ensemble frequency and amplitude analysis. Time analysis could be added at an extra £3500 with either the TMC correlator or Noratom tape deck.

2. Spectral Dynamics Corporation

(See table IV 1st system)

- 1 - Mechanical Impedance Analyser

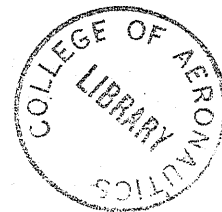

- 1 - Dynamic Analyser tuner (Sweep Oscillator)
- 1 - Linear/log sweep generator
- 2 - Multi-channel averagers
- 2 - XY recorders

plus

Technical Products Company

Amplitude Probability Analyser

Price £13,940.

System 2 would be capable of single channel amplitude analysis motion/force analysis twin channel frequency analysis and shaker control.

3. Gulton Industries

OF-3 Analyser system with a single multiplier and signal detector,

plus

Technical Products Company

Amplitude probability analyser

Price £10,700.

System 3 would be capable of single channel amplitude analysis, twin channel frequency analysis.

4. Noratom - I.S.A.C.

Price £5637

System 4 is capable of single channel amplitude analysis, and frequency analysis with twin channel time analysis.

The above 4 systems apart from the Noratom, have a frequency range between 3 - 25,000 c/s. The Noratom is restricted to the frequency range 0 - 200 c/s.

In the case of systems 1, 2 and 3 amplitude analysis and frequency analysis can be performed simultaneously.

The Noratom analysis is serial.

2.0 Definition of the True Mathematical Functions for which measured estimates are desired.

2.1 Mathematical Functions for Periodic Data

The following descriptive functions apply to a time history record  $x(t)$  of length  $T$  seconds for which a fundamental time period,  $T_p$  seconds, exists.

2.1.1 Mean Value

$$\bar{x} = \frac{1}{T_p} \int_0^{T_p} x(t) dt \quad (1)$$

Variance Value

$$\sigma_x^2 = \frac{1}{T_p} \int_0^{T_p} (x(t) - \bar{x})^2 dt \quad (2)$$

Mean Square Value

$$\overline{x^2} = \frac{1}{T_p} \int_0^{T_p} x^2(t) dt \quad (3)$$

The mean value, variance value and mean square value are related by:

$$\overline{x^2} = \sigma_x^2 + (\bar{x})^2 \quad (4)$$

2.1.2 A periodic time history record may be expressed by a Fourier Series. The amplitude form of the time history record  $x(t)$  is here considered compounded from an amplitude component at zero frequency (DC component) plus an infinitude of sinusoidal components having amplitudes  $c_n$  and phase angles  $\phi_n$  at frequencies  $nf_1$ .  $f_1$  is the fundamental frequency.

$$x(t) = C_0 + \sum_{n=1}^{\infty} c_n \text{Cos} (2\pi n f_1 t + \phi_n) \quad (5)$$

2.2 Mathematical Functions for Random Data

The following descriptive functions are for time history records  $x(t)$  which are random. The time history records are each of length  $T$  seconds and must be weakly stationary. The records may or may not belong to a stochastic process.

2.21 Mean Value

$$\bar{x} = \lim_{T \rightarrow \infty} \frac{1}{T} \int_0^T x(t) dt \quad (6)$$

Variance Value

$$\sigma_x^2 = \lim_{T \rightarrow \infty} \frac{1}{T} \int_0^T [x(t) - \bar{x}]^2 dt \quad (7)$$

Mean Square Value

$$\overline{x^2} = \lim_{T \rightarrow \infty} \frac{1}{T} \int_0^T x^2(t) dt \quad (8)$$

the mean, variance and mean square as defined above are related by equation (4).

2.22 Description in the Amplitude Domain

1st Order Probability Density Functions

The probability that  $x(t)$  assumes particular amplitude values between  $x$  and  $x + \Delta x$  is given by:

$$P[x < x(t) \leq x + \Delta x] = \lim_{T \rightarrow \infty} \frac{1}{T} \sum_{i=1}^n t_i(x, x+\Delta x) \quad (9)$$

Equation (9) is the (cumulative) probability distribution function.  $t_i$  is the time spent by  $x(t)$  in the range  $x$  to  $x+\Delta x$  during its  $i$ th entry into the range. If  $x$  is a particular value of  $x(t)$  and  $\Delta x$  is very small the first order probability density function is given by  $p(x)$ .

$$P[x < x(t) \leq x+\Delta x] = \lim_{\Delta x \rightarrow 0} \Delta x p(x)$$

$$\therefore p(x) = \lim_{\Delta x \rightarrow 0} \frac{1}{\Delta x} p[x < x(t) \leq x+\Delta x]$$

and

$$p(x) = \lim_{\Delta x \rightarrow 0} \lim_{T \rightarrow \infty} \frac{1}{T \Delta x} \sum_{i=1}^n t_i(x, x+\Delta x) \quad (10)$$

The Rayleigh Probability density function is given by:

$$p\left(\frac{x_o}{x_r}\right) = \left(\frac{x_o}{x_r}\right) \text{Exp.} \left[ \frac{-(x_o/x_r)^2}{2} \right] \quad (11)$$

$x_o/x_r$  being the ratio of peak to RMS amplitude.

### 2.23 Description in the Time Domain, Autocorrelation Function

For a time delay or lag of  $\tau$  seconds within  $x(t)$  the autocorrelation function is defined as:

$$R_x(\tau) = \lim_{T \rightarrow \infty} \frac{1}{T} \int_0^T x(t)x(t+\tau)dt \quad (12)$$

The autocorrelation function is a real valued even function which may be positive or negative.

Note that the autocorrelation function is derived from the auto-covariance function

$$\rho_x(\tau) = \lim_{T \rightarrow \infty} \frac{1}{T} \int_0^T [x(t) - \bar{x}(t)] [x(t+\tau) - \bar{x}(t+\tau)] dt \quad (13)$$

for the case where the mean values  $\bar{x}(t)$  and  $\bar{x}(t+\tau)$  are zero.

Note also the relationship:

$$\rho_x(\tau) = R_x(\tau) - (\bar{x})^2 \quad (14)$$

### Correlation Coefficient

$$\Gamma_x(\tau) = \frac{R_x(\tau)}{R_o(\tau)} \quad (15)$$

$\Gamma_x(\tau)$  lies between  $\pm 1$ .

### 2.24 Description in the Frequency Domain. Mean Square Spectral Density Function

For an ideal noise bandwidth of  $B$  c/s where  $B$  is small the mean square spectral density function is given by:

$$G_x(f) = \lim_{T \rightarrow \infty} \lim_{B \rightarrow \infty} \frac{1}{TB} \int_0^T x_B^2(f,t) dt \quad (16)$$

where  $f$  is the centre frequency of the narrow frequency band  $B$  c/s.  $x_B^2(f,t)$  is the filter of width  $B$  c/s and centre frequency  $f$  c/s.

$G_x(f)$  is a real valued function which is always positive.

The true mathematical definition of the mean square spectral density function involves both positive and negative frequencies.  $S_x(f)$  is the true function and is related to  $G_x(f)$  by:

$$G_x(f) = 2S_x(f) \quad (17)$$

for  $0 < f \leq \infty$

$G_x(f)$  is the physically realisable mean square spectral density function.

### 2.3 Joint Properties of a pair of random time history records

The following descriptive functions are for a pair of time history records  $x(t)$  and  $y(t)$  each of length  $T$  seconds, both of which are random. Both records must be weakly stationary and may or may not belong to a stochastic process.

#### 2.31 Joint Description in the Amplitude Domain.

##### Joint Amplitude Probability Density Function

The probability that  $x(t)$  and  $y(t)$  simultaneously take amplitude values within the ranges  $x$  to  $x+\Delta x$  and  $y$  to  $y+\Delta y$  is given by

$$\begin{aligned} & p[x < x(t) \leq x+\Delta x; y < y(t) \leq y+\Delta y] \\ & = \lim_{T \rightarrow \infty} \frac{1}{T} \sum_{i=1}^n t_i(x, x+\Delta x; y, y+\Delta y) \end{aligned} \quad (18)$$

$t_i$  is the time spent by  $x(t)$  and  $y(t)$  whilst they are simultaneously in the range  $x$  to  $x+\Delta x$  and  $y$  to  $y+\Delta y$  during the  $i$ th simultaneous entry into the ranges.

The joint amplitude probability density function is  $p(x,y)$  where:

$$\begin{aligned} & p[x < x(t) \leq x+\Delta x; y < y(t) \leq y+\Delta y] = \\ & = \lim_{\Delta x \rightarrow 0} \lim_{\Delta y \rightarrow 0} \Delta x \Delta y p(x,y) \end{aligned} \quad (19)$$

$$\therefore p(x,y) = \lim_{\Delta x \rightarrow 0} \lim_{\Delta y \rightarrow 0} \frac{1}{\Delta x \Delta y} p[x < x(t) \leq x+\Delta x; y < y(t) \leq y+\Delta y]$$

$$\text{or } p(x,y) = \lim_{\Delta x \rightarrow 0} \lim_{\Delta y \rightarrow 0} \lim_{T \rightarrow \infty}$$

$$\frac{1}{T\Delta x\Delta y} \sum_{i=1}^n t_i(x, x+\Delta x; y, y+\Delta y) \quad (20)$$

### 2.32 Joint Description in the Time Domain

#### Cross Correlation Function

For a time delay or lag of  $\tau$  seconds between  $x(t)$  and  $y(t)$  the cross correlation function is defined as:

$$R_{xy}(\tau) = \lim_{T \rightarrow \infty} \frac{1}{T} \int_0^T x(t) x(t+\tau) dt \quad (21)$$

$R_{xy}(\tau)$  is an odd function which may be positive or negative.

$$\left. \begin{array}{l} \text{i.e. } R_{xy}(\tau) \neq R_{xy}(-\tau) \\ \text{but } R_{xy}(\tau) = R_{yx}(-\tau) \end{array} \right\} \quad (22)$$

#### Cross Correlation Coefficient

$$\Gamma_{xy}(\tau) = \frac{R_{xy}(\tau)}{[R_{xx}(0)R_{yy}(0)]^{1/2}} \quad (23)$$

$\Gamma_{xy}(\tau)$  takes values in the range  $\pm 1$ .

### 2.33 Joint Description in the Frequency Domain.

#### Cross Spectral Density Function

For an ideal noise bandwidth of  $B$  c/s, where  $B$  is small and  $f$  c/s is the centre frequency of the narrow frequency band  $B$  c/s, the cross spectral density function is defined as:

$$G_{xy}(f) = C_{xy}(f) - jQ_{xy}(f) \quad (24)$$

i.e.  $G_{xy}(f)$  is a complex valued quantity having a real part  $C_{xy}(f)$  called the Co-Spectrum and imaginary part  $Q_{xy}(f)$  called the Quadrature Spectrum.

$$\text{where } C_{xy}(f) = \lim_{T \rightarrow \infty} \lim_{B \rightarrow 0} \frac{1}{TB} \int_0^T x_B(f,t) y_B(f,t) dt \quad (25)$$

and

$$Q_{xy}(f) = \lim_{T \rightarrow \infty} \lim_{B \rightarrow 0} \frac{1}{TB} \int_0^T x_B(f,t) \cdot y_B(f,t) dt \quad (26)$$

$x_B(f,t)$  is the amplitude passed by the narrow filter of equivalent ideal noise bandwidth  $B$  c/s and centre frequency  $f$  c/s.  $y_B(f,t)$  is the amplitude passed by a identical narrow filter also of width  $B$  c/s and centre frequency  $f$  c/s.

$\tilde{x}_B(f,t)$  has the same amplitude value as  $x_B(f,t)$  but is displaced  $90^\circ$  out of phase with  $y_B(f,t)$ .

$G_{xy}(f)$  may alternatively be expressed in complex polar co-ordinate form i.e.

$$G_{xy}(f) = |G_{xy}(f)| \text{Exp } j\theta_{xy}(f) \quad (27)$$

where  $|G_{xy}(f)|$  is the modulus or magnitude of  $G_{xy}(f)$  and is given by:

$$|G_{xy}(f)| = \left( C_{xy}^2(f) + Q_{xy}^2(f) \right)^{\frac{1}{2}} \quad (28)$$

and  $\theta_{xy}(f)$  is the phase factor of  $G_{xy}(f)$

$$\text{i.e. } \theta_{xy}(f) = \tan^{-1} \frac{-Q_{xy}(f)}{C_{xy}(f)} \quad (29)$$

#### Coherence function

$$\gamma_{xy}^2(f) = \frac{G_{xy}(f) \cdot G_{yx}(f)}{G_x(f) G_y(f)}$$

or

$$\gamma_{xy}^2(f) = \frac{|G_{xy}(f)|^2}{G_x(f) G_y(f)} \quad (30)$$

Note that  $\gamma_{xy}^2(f)$  takes values in the range  $\pm 1$ .

### 2.4 The mathematical properties of Stochastic Processes

#### 2.4.1 Statistical description of Stochastic processes which are weakly stationary

In virtue of their weak stationarity the following properties are true for all time.



For an ensemble of random time history records or sample functions  $\{x(\alpha, t)\}$  where each sample function is of length  $T$  seconds and a member of the stochastic process the following properties exist.

2.411 Ensemble Mean Value

$$\mu_x = E_{\alpha} \{x(\alpha, t)\} \quad (31)$$

the mathematical expectancy  $E$  is a limiting process, involving an infinitude of sample functions  $x(\alpha, t)$ .

i.e. 
$$E_{\alpha} \{x(\alpha, t)\} = \lim_{\alpha \rightarrow \infty} \frac{1}{\alpha} \sum_{\alpha=1}^{\infty} x(\alpha, t) \quad (32)$$

Ensemble Variance Value

$$\sigma_x^2 = E_{\alpha} \{[x(\alpha, t) - \mu_x]^2\} \quad (33)$$

Ensemble Mean Square Value

$$\mu_x^2 = E_{\alpha} \{x^2(\alpha, t)\} \quad (34)$$

Note that the following relationship exists

$$\mu_x^2 = \sigma_x^2 + (\mu_x)^2 \quad (35)$$

2.412 Description of Stochastic processes in the time Domain

Covariance Function

$$\rho_x(\tau) = E_{\alpha} \{[x(\alpha, t) - \mu_x][x(\alpha, t+\tau) - \mu_x(t+\tau)]\} \quad (36)$$

the covariance function is computed across the ensemble of sample functions at times  $t_1$  and  $t_2$  where the difference  $t_2 - t_1 = \tau$ .

Auto Correlation Function

If the mean values  $\mu_x$  and  $\mu_x(t+\tau)$  are zero in the covariance function,

or can be subtracted out, the covariance function reduces to the auto-correlation function.

$$\text{i.e. } R_x(\tau) = E_{\alpha} \left\{ [x(\alpha, t) \cdot x(\alpha, t+\tau)] \right\} \quad (37)$$

Note the relationship between the covariance and auto-correlation function

$$\rho_x(\tau) = R_x(\tau) - \mu_x^2 \quad (38)$$

### 2.413 Description of a Stochastic Processes in the Amplitude Domain

#### First order amplitude probability density function

The probability that  $\{x(\alpha, t)\}$  assumes a particular amplitude value between  $x$  and  $x+\Delta x$  at some time  $t$  is given by:-

$$\begin{aligned} P[x < \{x(\alpha, t)\} \leq x+\Delta x] \\ = \lim_{\alpha \rightarrow \infty} \frac{1}{\alpha} N(x, x+\Delta x) \end{aligned} \quad (39)$$

where  $N(x, x+\Delta x)$  is the number of times that the amplitude value of the sample functions falls in the range  $x$  to  $x+\Delta x$ .

If  $\Delta x$  is very small the first order probability density function is given by  $p(x)$ .

$$\text{i.e. } p(x) = \lim_{\alpha \rightarrow \infty} \lim_{\Delta x \rightarrow 0} \frac{1}{\alpha \Delta x} N(x, x+\Delta x) \quad (40)$$

### 2.42 Joint properties of a pair of weakly stationary Stochastic processes

For a pair of weakly stationary stochastic process  $\{x(\alpha, t)\}$  and  $\{y(\alpha, t)\}$  joint properties in the amplitude domain are as follows:

#### 2.421 Joint Amplitude probability density function

The probability that  $\{x(\alpha, t)\}$  and  $\{y(\alpha, t)\}$  assume particular amplitude values in the ranges  $x$  to  $x+\Delta x$  and  $y$  to  $y+\Delta y$  simultaneously, is given by:

$$\begin{aligned} p[x < \{x(\alpha, t)\} \leq x+\Delta x; y < \{y(\alpha, t)\} \leq y+\Delta y] \\ = \lim_{\alpha \rightarrow \infty} \frac{1}{\alpha} N(x, x+\Delta x; y, y+\Delta y) \end{aligned} \quad (41)$$

$N(x, x+\Delta x; y, y+\Delta y)$  is the number of times that the amplitude value of sample functions simultaneously fall in the range  $x$  to  $x+\Delta x$  and  $y$  to  $y+\Delta y$ .

If  $\Delta x$  and  $\Delta y$  are very small the second order amplitude probability density function is given by:  $p(x, y)$

$$\text{i.e. } p(x, y) = \lim_{\alpha \rightarrow \infty} \lim_{\Delta x \rightarrow 0} \lim_{\Delta y \rightarrow 0} \frac{1}{\alpha \Delta x \Delta y} N(x, x+\Delta x; y, y+\Delta y) \quad (42)$$

## 2.422 Joint Description in the Time Domain

### Cross Covariance function

$$\rho_{xy}(\tau) = E_{\alpha} \left\{ [x(\alpha, t) - \mu_x][y(\alpha, t+\tau) - \mu_y(t+\tau)] \right\} \quad (43)$$

$\tau$  is the time displacement on lag between the two processes  $\{x(\alpha, t)\}$  and  $\{y(\alpha, t)\}$  and  $\mu_x$  and  $\mu_y$  are their mean values respectively.

If  $\mu_x$  and  $\mu_y$  are zero  $\rho_{xy}(\tau)$  reduces to the cross correlation function.

### Cross Correlation Function

$$R_{xy}(\tau) = E_{\alpha} \left\{ x(\alpha, t)y(\alpha, t+\tau) \right\}$$

Note that  $R_{xy}(\tau)$  is an odd function and may be either positive or negative.

## 2.43 Statistical Description of Stochastic processes which are Non-stationary

For the case of non stationary stochastic processes, the ensemble averages in general will be a function of the particular time and for joint properties of the particular times at which they are computed.

The equivalent non stationary descriptions for the above mentioned singular and joint properties are as follows.

### Ensemble Mean Value

$$\mu_x(t) = E_{\alpha} \left\{ x(\alpha, t) \right\} \quad (45)$$

$$\mu_x(t_1) \neq \mu_x(t_2) \quad (46)$$

Ensemble Variance Value

$$\sigma_x^2(t) = E_{\alpha} \left\{ [x(\alpha, t) - \mu_x(t)]^2 \right\} \quad (47)$$

$$\sigma_x^2(t_1) \neq \sigma_x^2(t_2) \quad (48)$$

Ensemble Mean Square Value

$$\mu_x^2(t) = E_{\alpha} \left\{ x^2(\alpha, t) \right\} \quad (49)$$

$$\mu_x^2(t_1) \neq \mu_x^2(t_2) \quad (50)$$

Covariance Function

$$\rho_x(t_1, t_2) = E_{\alpha} \left\{ [x(\alpha, t_1) - \mu_x(t_1)][x(\alpha, t_2) - \mu_x(t_2)] \right\} \quad (51)$$

Cross Covariance Function

$$\rho_{xy}(t_1, t_2) = E_{\alpha} \left\{ [x(\alpha, t_1) - \mu_x(t_2)][y(\alpha, t_2) - \mu_y(t_2)] \right\} \quad (52)$$

Auto-correlation Function

$$R_x(t_1, t_2) = E_{\alpha} \left\{ x(\alpha, t_1)x(\alpha, t_2) \right\} \quad (53)$$

Cross Correlation Function

$$R_{xy}(t_1, t_2) = E_{\alpha} \left\{ x(\alpha, t_1)y(\alpha, t_2) \right\} \quad (54)$$

First Order Amplitude Probability Density Function

$$p(x, t) = \lim_{\alpha \rightarrow \infty} \lim_{\Delta x \rightarrow 0} \frac{1}{\alpha \Delta x} N(x, x+\Delta x) \quad (55)$$

Second Order Amplitude Probability Density Function

$$p(x, y, t) = \lim_{\alpha \rightarrow \infty} \lim_{\Delta x \rightarrow 0} \lim_{\Delta y \rightarrow 0} \frac{1}{\alpha \Delta x \Delta y} N(x, x+\Delta x; y, y+\Delta y) \quad (56)$$

2.44 Description of Weakly Stationary and Non Stationary Stochastic processes in the Frequency Domain

2.441 In a weakly stationary stochastic process the mean square spectral density function is interpreted as the ensemble average of the mean square spectral density functions for the individual sample functions. Each sample function being of length T seconds.

$$\text{i.e. } G_X(f) = E_{\alpha} \left\{ G_X(\alpha, f) \right\} \quad (57)$$

$$\text{where } G_X(\alpha, f) = \lim_{T \rightarrow \infty} \lim_{B \rightarrow 0} \frac{1}{BT} \int_0^T x_B^2(\alpha, t) dt \quad (58)$$

$\alpha$  denotes functional dependence of  $G_X(f)$  on a particular sample function from the stochastic process.

For weakly stationary stochastic processes, the auto-correlation function and mean square spectral density function are Fourier Transform pairs.

$$\text{i.e. } G_X(f) = 4 \int_0^{\infty} R_X(\tau) e^{-j2\pi f\tau} d\tau \quad (59)$$

$$= 4 \int_0^{\infty} R_X(\tau) \cos 2\pi f\tau d\tau \quad (60)$$

$$\text{and } R_X(\tau) = \int_0^{\infty} G_X(f) e^{j2\pi f\tau} df \quad (61)$$

$$= \int_0^{\infty} G_X(f) \cos 2\pi f\tau df \quad (62)$$

where  $R_X(\tau)$  and  $G_X(f)$  are defined by the ensemble averages in equations (37) and (57) respectively.

Similar Transform pairs, also exist for the Cross Spectral Density function and Cross Correlation function, they are:-

$$G_{xy}(f) = 4 \int_0^{\infty} R_{xy}(\tau) e^{-j2\pi f\tau} d\tau \quad (63)$$

$$= 4 \int_0^{\infty} R_{xy}(\tau) \cos 2\pi f\tau d\tau \quad (64)$$

and 
$$R_{xy}(\tau) = \int_0^{\infty} G_{xy}(f) e^{j2\pi f\tau} df \quad (65)$$

$$= \int_0^{\infty} G_{xy}(f) \cos 2\pi f\tau df \quad (66)$$

here  $G_{xy}(f)$  and  $R_{xy}(\tau)$  are obtained from ensemble averaging the individual sample functions.

i.e. 
$$G_{xy}(f) = E_{\alpha} \left\{ G_{xy}(\alpha, f) \right\} \quad (67)$$

and  $R_{xy}(\tau)$  is given by equation (44).

#### 2.442 The Mean Square Spectral Density Function for Non Stationary Stochastic Processes

For the stationary case, the mean square spectral density function is a function of the centre frequency only of a narrow equivalent ideal noise bandwidth B c/s.

i.e.  $B = f_2 - f_1.$

and  $f = \frac{f_2 + f_1}{2}$

For the non stationary case the MSSD function is a function of the two ideal cut off frequencies  $f_1$  and  $f_2$ .

Using again the Fourier Transform concept, the Generalised Non Stationary Mean Square Spectral Density Function is given by:

$$S_x(f_1, f_2) = \int_{-\infty}^{\infty} \int_{-\infty}^{\infty} R_x(t_1, t_2) e^{j2\pi(f_1 t_1 - f_2 t_2)} dt_1 dt_2 \quad (68)$$

$R_x(t_1, t_2)$  is the non stationary auto-correlation function given in equation (53).

Note that  $G_x(f_1, f_2) = 16 S_x(f_1, f_2)$  for  $0 < f \leq \infty$  (69)

also 
$$R_x(t_1, t_2) = \int_{-\infty}^{\infty} \int_{-\infty}^{\infty} S_x(f_1, f_2) e^{-j2\pi(f_1 t_1 - f_2 t_2)} df_1 df_2 \quad (70)$$

The generalised non stationary Cross Spectral Density Function is given by:

$$S_{xy}(f_1, f_2) = \int_{-\infty}^{\infty} \int_{-\infty}^{\infty} R_{xy}(t_1, t_2) e^{j2\pi(f_1 t_1 - f_2 t_2)} dt_1 dt_2 \quad (71)$$

and 
$$R_{xy}(t_1, t_2) = \int_{-\infty}^{\infty} \int_{-\infty}^{\infty} S_{xy}(f_1, f_2) e^{-j2\pi(f_1 t_1 - f_2 t_2)} df_1 df_2 \quad (72)$$

again  $G_{xy}(f_1, f_2) = 16 S_{xy}(f_1, f_2)$

for  $0 < f \leq \infty$

where  $R_{xy}(t_1, t_2)$  is the non stationary cross correlation function for a stochastic process given in equation (54).

## 2.5 Input/Output Relationships for Constant parameter Linear Systems subject to weakly stationary Random Excitation

### 2.5.1 Frequency Response Function

The complex Frequency response function  $H(f)$  may be written as a complex number in the form:

$$H(f) = \text{Re}[H(f)] + j\text{Im}[H(f)] \quad (73)$$

The real part of  $H(f)$  is known as the modulus, gain or transmissibility factor. The imaginary part of  $H(f)$  is the phase factor.  $H(f)$  may also be written in complex polar notation:

$$H(f) = |H(f)| e^{j\phi(f)} \quad (74)$$

where  $|H(f)|$  is the gain factor and  $\phi(f)$  is the phase factor.

For weakly stationary random excitation of a constant parameter linear system having a linear frequency response function  $H(f)$ , the input/output relationship is given by the ratio of output MSSD to Input MSSD

i.e. 
$$\frac{G_y(f)}{G_x(f)} = |H(f)|^2 \quad (75)$$

$G_y(f)$  is the output and response spectrum

$G_x(f)$  the input or excitation spectrum and  $|H(f)|$  the gain factor of the frequency response function.

Other Input/Output relationships for the Frequency Response Function

From the cross spectral density function

$$G_{xy}(f) = H(f)G_x(f) \quad (76)$$

which reduces to

$$|G_{xy}(f)| = |H(f)|G_x(f) \quad (77)$$

from:

$$|G_{xy}(f)| e^{j\theta_{xy}(f)} = |H(f)| e^{j\phi(f)} G_x(f) \quad (78)$$

$\theta_{xy}(f)$  is the phase factor for the cross spectral density function,  
 $\phi(f)$  is the phase factor for the frequency response function.

Note that  $\theta_{xy}(f) = \phi(f)$ .

Time delay and phase angle are related by the expression

$$\tau_{xy}(f) = \frac{\theta_{xy}(f)}{2\pi f} = \frac{\phi(f)}{2\pi f} \quad (79)$$

From the coherence function the gain factor of the Frequency response function is given by:

$$|H(f)| = \frac{\gamma_{xy}(f) \cdot G_y(f)}{G_x(f)} \quad (80)$$

2.52 Transfer Function

This is defined as the ratio of

$$H(s) = \frac{y(s)}{x(s)} \quad (81)$$

where  $H(s)$  is the transfer function

$y(s)$  is the Laplace Transform of the output variable

$x(s)$  is the Laplace Transform of the input variable

and  $s$  is a complex quantity of the form

$$S = \xi + j\omega \quad (82)$$

In complex polar notation:

$$H(s) = |H(s)| e^{st} \quad (83)$$



For steady state motion  $\xi = 0$  in  $s$

$\therefore s = j\omega$

the transfer function then reduces to the frequency response function given by equation (74).

## 2.6 Motion/Force relationships for physical systems

### 2.6.1 Mechanical Impedance

Mechanical impedance is a complex quantity relating the force to the velocity at a point in a physical system.

$$z(f) = \operatorname{Re}[z(f)] + j\operatorname{Im}[z(f)] \quad (84)$$

and  $z(f) = |z(f)| e^{j\phi_z(f)} \quad (85)$

$$|z(f)| = \frac{F}{\dot{x}} \quad (86)$$

Other Motion/Force relationships are

$$\text{Mobility} = \frac{\dot{x}}{F} = \frac{1}{z} \quad (87)$$

$$\text{Compliance} = \frac{x}{F} \quad (88)$$

$$\text{Inertance} = \frac{\ddot{x}}{F} \quad (89)$$

$$\text{Apparent Mass} = \frac{F}{\ddot{x}} \quad (90)$$

$$\text{Apparent or Dynamic Stiffness} = \frac{F}{x} \quad (91)$$

### 3.0 Appraisal of the Systems

#### 3.1 Objectives of the Systems

Table I shows for each system, which of the functions of interest, it is capable of plotting automatically.

##### 3.1.1 Ad-Yu Type 1010 Automatic Analysis System

1. To plot automatically, mechanical impedance, power spectral density, and complex frequency response for a pair of time history records.
2. To provide a control signal and power amplification for a shaker.

##### 3.1.2 Fenlow Spectrum Analyser with Automatic Attachment

To plot automatically the power spectral density function for a single record.

##### 3.1.3 Gultom Industries Automatic Spectrum Analyser Systems

###### Type OR-WA/1 Wave Analyser

To plot automatically, power spectral density, amplitude spectral density, Fourier series and Fourier integrals. To record the peak amplitude of a single time history record.

###### Type OIP/1 Transmissibility ratio plotter

To plot automatically for a pair of records, the non-complex frequency response function and amplitude spectral density. To record the peak amplitude value for each record.

###### Type OF/3 Transfer Function Analyser

To plot automatically the Co-Spectrum and Quad Spectrum, the complex frequency response function, the non-complex frequency response function and the power spectral and amplitude spectral density function for a pair of records. To record the peak amplitude of each record.

##### 3.1.4 Honeywell Series 9300 (A and B) Automatic Spectrum Analyser

###### Honeywell 9410 Time Delay Correlator

9300 To plot automatically:

Fourier Series  
Fourier Integral  
Power Spectral Density  
Peak Amplitude v Frequency

Non Complex Frequency Response  
Complex Frequency Response  
Amplitude or Amplitude Squared v Frequency for a pair of records.

9410 To plot automatically Auto and Cross Correlation of a single or pair of records.

### 3.1.5 Noratom: Instrument for Statistical Analogue Computations

To plot automatically, for a single or pair of records:

1st Order Amplitude Probability Distribution.  
Auto and Cross Correlation  
Power and amplitude spectral density.

### 3.1.6 Spectral Dynamics Corporation

To plot automatically mechanical impedance and other force/motion relationships.

To provide a shaker with a control signal.

To plot automatically power spectral density for a pair of records.

To plot automatically the non-complex frequency response function.

### 3.1.7 Technical Measurement Corporation

Computer of Average Transients and Correlation Computer

To compute automatically and ON-LINE for an ensemble of time history records, the mean value, amplitude probability density, amplitude probability distribution and peak amplitude value.

To compute automatically and ON-LINE the Auto correlation and Cross correlation for a single or pair of time history records.

### 3.1.8 Technical Products Company

TP 625 Wave Analyser Systems

To compute automatically the functions shown in table 1. To provide a shaker with a control signal.

### 3.2 Separation and allocation of Man/Machine functions in the realisation of System Objectives

#### 3.2.1 Ad-Yu

Machine Functions. See Fig. 1.

In addition to the functions shown in Fig. 1 the system monitors the input voltages and indicates the instantaneous R.M.S. level. It automatically cancels the mass of the impedance head.

Man Functions

Control the Start and Stop of Analysis.

Monitor input voltage levels on an R.M.S. meter.

Adjust the input gain and note the effect of this on the system calibration

Calibrate the scales of the strip-chart records.

Select:

Record length  
Averaging time  
Averaging time constant  
Filter Bandwidth  
Frequency Scan Rate.

Operate strip-chart recorders.

#### 3.2.2 Fenlow

Machine Functions

Amplifies or Attenuates the input signal voltage.

Frequency filters the input signal by means of an active low pass filter.

Squares the filter output voltage using square-law thermocouples.

Averages the squared filtered signal.

Plots automatically P.S.D. and Frequency on an XY recorder.

Man Functions

Control Start and Stop of Analysis.

Monitor the level of the input signal.

Adjust the input gain control and note its effects on the system calibration.

Select and alter the analysis frequency range.

Select:

- Record length
- Averaging time
- Averaging time constant
- Filter bandwidth
- Frequency scan rate.

Calibrate scales on the XY recorder.

Perform division of the plotted power spectral density curve by the filter bandwidth.

3.2.3 Gulton Systems

Machine Functions - See Fig. 4.

In addition to the functions shown in Fig. 4 the Gulton systems have:

- Automatic Frequency range programming
- Automatic bandwidth switching
- Automatic calibration of the frequency axis.

Man Functions

Control Start of Analysis.

Monitor the input signal level.

Adjust the input gain control.

Note effect of this on the system calibration.

Select:

- Mode of detection
  - Linear
  - Square law
  - Peak amplitude



Frequency range and programme.  
Record length.  
Averaging time.  
Type of Averaging.  
Averaging time constant.  
Filter bandwidth (s)  
Frequency scan rate.

Calibrate the scales on the Y axis only of the XY recorder.

### 3.2.4 Honeywell

Machine Functions - see Figs. 6, 7, 8 and 9.

#### Man Functions

Control Start and Stop of Analysis.

Monitor input signal level.

Adjust input amplifier gain control.

Note the input gain and its effect on the output voltage calibration.

Select:

Record length.  
Averaging time.  
Averaging time constant.  
Filter bandwidth.  
Frequency scan rate.

Calibrate the scales on the X and Y axis of the recorder.

#### 9300B System

Apply input voltage.

Programme the:

Filter Bandwidths  
Frequency Range  
Frequency Scan Rate.

Select:

Mode of operation.  
Step or Sweep.  
Mode of scan  
Linear or ramp.

Type of Averaging  
Integration or RC.  
Integration time or Averaging time.  
(Select RC Averaging time constant)  
Mode of detection  
Linear  
Square  
Peak.  
Control Start of Analysis.

9410 System

Apply input voltage.  
Start and Stop Analysis.  
Monitor input voltage level.

Note the effect of any change in the input gain on the output voltage calibration.

Select:

Time delay range.  
Time delay sweep rate.  
Averaging time.  
Record length.

Calibrate the scales of the XY recorder.

3.2.5 Noratom - I.S.A.C.

Machine Functions - See Fig. 11.

In addition to the functions shown in Fig. 11, ISAC has its own self contained magnetic tape reproducer/recorder and is capable of a wide range of tape speed

Man Functions

Record the electrical analogue voltage on to the appropriate magnetic tape channel.

Monitor the input voltage level.

Adjust the input amplifier gain control.

Note what effect the input gain control has on the output voltage calibration.

Initiate the Start of Analysis.

Select:

Appropriate Recording Speed.  
Integration time for Correlation.  
Frequency Sweep Rate  
Mode of Detection  
    Square  
    Linear  
Mode of Analysis:  
    - Amplitude  
    - Time  
    - Frequency.

Calibrate the axis of the XY recorder for each of the three functions computed.

### 3.2.6 Spectral Dynamics Corporation

Machine Functions - See Fig. 14

In addition to the machine functions shown in Fig. 14 the S.D.C. system provides a unique tracking frequency multiplier. This unit accepts any periodic input signal which it converts to a sine wave of the same frequency. This frequency can then be multiplied over an infinitely variable range from 0.1 - 150. This multiplied frequency signal is then used to tune the centre frequency of a tracking filter.

The machine also performs automatic bandwidth switching.

Man Functions

Control the start and stop of analysis.

Monitor the input signal voltage.

Adjust the input gain control.

Note effect of any change in the input gain on the output voltage calibration.

Select:

Record length.  
Filter bandwidth(s)  
Mode of frequency scan  
    - linear  
    - log  
Frequency scan rate.  
Averaging time.



Programme:

Filter bandwidths.  
Frequency range.

Calibrate the scales of the XY recorder.

### 3.2.7 Technical Measurement Corporation

C.A.T. of COR Computers

Machine Functions - See Fig. 16.

Man Functions

C.A.T. Control Start of Analysis.

Select:

No. of records  
Pre analysis delay.  
Analysis time.  
Mode of computation:  
- Add  
- Subtract  
Mode of Output:  
- Analogue  
- Digital.

Control the oscilloscope display.

C.A.T. and C.O.R.

As from the C.A.T. plus:

Section of:

Mode of Operation  
- Auto-correlation  
- Cross-correlation  
Time delay increment  
Analysis time.

Calibrate the axis of an XY recorder.

### 3.2.8 Technical Products Company

TP 625 Wave Analyser System

Machine Function - See Fig. 18

In addition to the functions shown in Fig. 18, as with the S.D.C. system, the T.P.C. analyser can take any periodic input signal and convert it to a sine wave of the same frequency. It can then use this sine wave as a tracking signal.

Man Functions

Control the start of analysis.

Monitor the input signal voltage.

Adjust input gain control.

Note setting of the gain control and its effect upon the output voltage calibration.

Select:

- Record length.
- Filter bandwidth.
- Bandwidth division.
- Mode of detection
  - Peak
  - Peak Squared
  - Mean
  - Mean Squared.
- Type of Averaging
  - True integration
  - R.C. Averaging
- Average time.
- Averaging time constant.
- Mode of Multiplication
  - Multiplication
  - Division
- Frequency Range.
- Frequency Scan Rate.
- Mode of Probability Analysis
  - Distribution
  - Density
  - Rayleigh
  - Joint
- No. of amplitude increments.
- Amplitude range.

Calibrate the scales of the XY recorder.

### 3.3 Specification of the Hardware.

See table II.

### 3.4 Design of the Hardware

#### 3.4.1 Ad-Yu

10 functional units are housed in a single desk-like cabinet, see Fig. 1. The units are as follows:

- 2 - channel input amplifiers
- 2 - channel frequency filter
- Sweep oscillator
- Integrating Amplifier
- 3- strip chart recorders
- Phase computer
- Power supply unit
- 50 watt power amplifier.

Although each functional unit of the Ad-Yu system requires a separate power supply it should be possible to use the units separately if so desired.

#### 3.4.2 Fenlow.

The Fenlow Spectrum Analyser is housed in a single cabinet  $16\frac{1}{2}''$  x  $19\frac{1}{2}''$  x  $10''$ . The analyser is a single function unit. The Automatic plotter attachment is in the form of an XY recorder. The automatic frequency scan is performed by a servo motor rotating a frequency calibrated dial.

The XY recorder would not be considered suitable as a general purpose instrument.

The system as a whole is semi portable.

#### 3.4.3 Gulton Systems (See Fig. 3)

##### Type OR-WA/1 Wave Analyser

8 functional units are rack mounted as shown in Fig. 3. They include:

- 1 - Pre-amplifier filter
- 1 - Modulator
- 1 - Detector Averager
- 1 - Oscillator
- 1 - Sweep Generator
- 1 - Power Control Panel
- 1 - Power supplies
- 1 - XY Recorder.

Optional extras are:-

Peak detector  
Automatic programmer

Type OTP-1 Transmissibility Ratio Plotter

As for the OR-WA/1 plus the following additional units:

1 - Pre-amplifier filter  
1 - Modulator/divider  
1 - Detector averager  
1 - Control unit.

Optional extras as before.

Type OF-3 Transfer Function Analyser

As for the CTP-1 plus:

1 - Pre-amplifier filter  
1 - Modulator divider  
1 - Detector averager  
1 - Two phase oscillator  
2 - Multiplier - dividers.

Extras as before.

With extras the OF-3 comprises 18 functional units. Although each functional unit requires a separate power supply, it should be possible to withdraw any unit from the system and use it individually.

3.4.4 Honeywell

9300 A and B Systems. See Fig. 6.

Both systems are fully transistorised. Individual functional units are rack mounted.

System complexity can be easily expanded by the addition of optional functional units.

The separate functional units could not be used away from the module.

9410 System. See Fig. 5.

A single purpose instrument individually housed in box  $16\frac{3}{4} \times 10\frac{1}{4} \times 7\frac{1}{2}$  inches.

3.4.5 Noratom - I.S.A.C.

See Figures 10 and 12. ISAC is built in 3 units plus an XY plotter.

Although weighty the system is regarded as transportable.

It would not be possible to withdraw a functional unit from ISAC and use it individually.

#### 3.4.6 Spectral Dynamics Corporation See Fig. 13.

S.D.C. build two basic functional units: A frequency tracking filter and tracking filter tuner.

These two units are fully self contained and designed for rack mounting. Each unit has associated with it a number of plug in adaptors.

The tracking filter unit has been designed so that additional filter units can be slaved to it. These slave units are built in pairs and rack mounted.

#### 3.4.7 Technical Measurement Corporation

C.A.T. and C.O.R. Computers. See Fig. 15.

The T.M.C. computer of average transients is a single functional unit to which a number of other units such as a correlator and amplitude probability discriminator may be slaved.

The C.A.T. and C.O.R. are both about the size of a large oscilloscope and are easily portable.

#### 3.4.8 Technical Products Company

TPC625 Wave Analyser System. See Fig. 17.

The TPC 625 wave analyser system is comprised of 6 functional units:

- 1 Oscillator - Sweep
- 2 Analyser with filters
- 3 Power integration
- 4 Multiplier
- 5 Probability analyser
- 6 Voltage controlled heterodyne oscillator,

any number of these units may be connected in a variety of ways to build up a system.

Each unit is fully self contained and can itself perform a variety of functions.

The units are designed for standard 19" rack mounting.

### 3.5 The Man/Machine Interface

#### 3.5.1 Ad-Yu

The available data on this system does not allow a critical appraisal.

#### 3.5.2 Fenlow

3 indicating meters are provided. A monitor meter for the input voltage level with a two-way switch for monitoring the signal before and after pre-filtering. A main meter indicating the machine output voltage - calibrated in units of power density. A meter for monitoring the in-phase and out of phase components of the filtered signal.

#### Controls

- Main ON/OFF switch.
- Pre-amplifier coarse gain.
- Pre-amplifier fine gain
- Frequency range
- Filter bandwidth
- Power sensitivity
- Averaging time
- Frequency tuning dial.

The machine output is also displayed on the XY recorder.

The input voltage monitor is barely adequate for the function it performs. It has no graduations to suggest a safe working range.

The machine output meter is useful only for very coarse qualitative assessments of power density.

The main filter monitor, it is thought, provides only redundant information.

#### 3.5.3 Gulton Systems

From the available data on these systems no critical assessment could be made. The controls of the machine seem, (from the illustration of the equipment figure 3) very complicated with no thought for hierarchy of position.

#### 3.5.4 Honeywell Systems

9300 For the degree of complexity the interface of the Honeywell 9300 analyser is notably simple and functional.

In the stepped mode of operation, the 9300 B system has a digital frequency display. The controls are as shown in Fig. 6. Machine output may be displayed either on an XY recorder or on a teleprinter.

9410

No input monitor is provided on this instrument.

Time delay is displayed on a circular dial.

Output of the machine is displayed on a centre zero meter or on an XY plotter.

The instrument controls are as shown in Fig. 9.

### 3.5.5 Noratom ISAC

The machine provides a magic-eye input voltage monitor for each input channel. These are graduated up to  $\pm 2.5V$ , are well situated and easy to use. The general control layout of ISAC is neat but the control knobs are cramped and sometimes difficult to operate. See Figs. 10 and 12.

Time delay is indicated on (not directly) a scale by the displacement of one replay head.

No indication is given for analysis frequency or amplitude discrimination level.

### 3.5.6 Spectral Dynamics Corporation

On the tracking filter unit an input voltage monitor and a filter output voltage monitor is provided.

On the tracking filter tuning unit a five digit frequency indicator is provided which will also read the order of frequency multiplication when the unit is used as a tracking frequency multiplier.

The machine controls can be seen in Fig. 13. The controls are generally uncramped and well marked.

### 3.5.7 Technical Measurement Corporation

C.A.T. and C.O.R. See Fig. 15.

The interface of these units are fairly simple, the controls are rather cramped but well marked and neat.

The output from the C.A.T. and C.O.R. may be displayed on the oscilloscope provided, or printed on a teleprinter on XY plotter.

No indication of time delay is needed on the C.O.R. since the machine computes all points on the correlogram simultaneously.

### 3.5.8 Technical Products Company

TP 625 Wave Analyser System See Fig. 17.

On the two system oscillators, analysis frequency is indicated on dials. On the sweep oscillator the frequency sweep rate is indicated on a meter. On the voltage controlled heterodyne oscillator it is displayed on a dial.

The input voltage monitor is provided on the Analyser in the form of a meter.

Output of the multiplier is displayed on a centre zero meter and reads in % of  $\pm 45$  volts.

The probability analyser has two meters indicating standard deviation and probability.

The controls of all these units can be seen in Fig. 17. They are very well marked and easy to operate.

### 3.6 Job Aids for the Data Analyst

All systems reviewed are supplied with a full instruction manual. The Fenlow and Spectral Dynamics Corporation analysers are supplied with calibrated graph paper for use on their XY recorders. Gulston, Honeywell, SDC, TMC and TPC include in the price of the analyser a period of training in its use. The Honeywell and TPC system included a special quick look mode of analysis for optimising the system parameters for statistical uncertainty.

The TPC system was the only system supplied with full calibration curves.

### 3.7 System Integration

All systems reviewed, apart from the Noratom, require the addition of a magnetic tape reproducer with loop adaptor and speed up facilities and signal conditioning equipment before they can be integrated.

Other exceptions are in the analysis of mechanical impedance. Here the Ad-Yu and Spectral Dynamics systems are fully integrated and ON-LINE when coupled to a shaker and force/acceleration transducer.

The T.M.C. Computer of Average transients being a digital computer operates in a fundamentally different way to the analogue systems. This machine does not require a magnetic tape reproducer. It is sold as a fully integrated ON-LINE system.



### 3.8 System Evaluation

The table below indicates the number of functions, out of the 56 listed in table 1, that the systems are capable of computing automatically or with the addition of some manual work.

System	Functions plotted automatically	Functions plotted with some manual work
Ad Yu	8	3
Fenlow	1	2
Gulston		
OR-WA/1	9	4
OTP-1	10	3
OF-3	16	5
Honeywell		
9300	18	7
9410	2	2
Noratom	7	3
S.D.C.	13	3
T.M.C.	14	4
T.P.C.	26	9

#### 3.8.1 Ad Yu

The Ad Yu system is primarily a mechanical impedance analyser and not a statistical analyser. As a mechanical impedance analyser it must be amongst the most accurate. Noteworthy in this respect is the Ad Yu reputation for accurate phase measurement. As a statistical analyser in the frequency domain it lacks the flexibility needed to control statistical uncertainty. Namely a good range of filter bandwidths and averaging time constants.

In its specification some notable points are the wide input voltage range of 5 $\mu$ V - 50V RMS, the dynamic range 140 db. Poor in its specification is the frequency range 5 - 10,000 c/s and scan rate 0.925 - 27.8 c/s/s.

No provision is made in the Ad Yu for the programming of filter bandwidths or frequency range.

#### 3.8.2 Fenlow Analyser

As a frequency filter the present brand of Fenlow analyser has some important virtues. Most important is its low frequency capability of 0.3 c/s and narrow bandwidth of 0.06 c/s. This low frequency capability means that

analysis of signals as low as 0.1 c/s require only a modest tape speed up. Coupled with the very narrow filter bandwidth there is a very slow frequency scan rate of  $9.06 \cdot 10^{-5}$  c/s/s. This gives the Fenlow a unique resolution capability.

Major drawback of the instrument is the need to switch the frequency range at 1.5 c/s, 7.5 c/s, 37.5 c/s and 187.5 c/s. A fixed detector circuit (square law and averaging) makes the instrument inflexible in this sense. Other drawbacks are:

- A low upper frequency limit.
- A slow upper scan rate limit.
- A poor range of averaging time constants.

Based on passed experience with the Fenlow and on its specification it is felt that the Fenlow in its present form should be reserved for those analyses requiring a high degree of spectral resolution or a quick-look.

### 3.8.3 Gulton Systems

Common to all the Gulton systems is a high degree of spectral resolution and a fairly high degree of computational flexibility. A wide data frequency range 3 - 30,000 c/s, a wide choice of filter bandwidths, the option of true averaging or RC averaging and a very high upper frequency scan rate of 3,000 c/s/s.

Two of the type OF-3 systems are currently in use in this country. The English Electric Co. Ltd., Whetstone have some three years experience with their system. E.E. have rebuilt their system so that each functional unit is self contained and capable of independent operation.

The most complex functions have been computed on this system with good results. Speed of analysis was stated as possibly the greatest virtue of this system. This to a large extent derives from the high scan rates available coupled with provision of a filter bandwidth and frequency range programming facility.

### 3.8.4. Honeywell Series 9300 B

The Honeywell Series 9300 B system is undoubtedly capable of the highest degree of statistical accuracy in computation. It is also the fastest analyser reviewed, and the simplest to operate.

The 9300 B achieves optimum statistical accuracy through the use of a stepped mode of operation. In this mode the centre frequency of the band pass filter is stepped on one bandwidth per record length. True integration is used to average in this mode and permits analysis at 4 times the speed of RC averaging. Two integrators are used, one integrating whilst the other is being read out and discharged. Record length on a magnetic tape loop can

be controlled from the integrators and can be adjusted to miss out that section of tape containing the tape splice. In this way errors due to bad tape slicing are avoided. Other noteworthy features are an automatic input voltage monitoring system, which automatically amplifies and attenuates the input signals if they become too large or too small. This it achieves through the use of a second set of bandpass filters in each input channel.

These filters are identical with the data filters. Their centre frequency being tuned are bandwidth higher than the data filters. In this way the machine is able to predict the voltages that the analyser filter is going to experience in the future and automatically adjusts the input gain accordingly. The true signal is re-established at the output recorder by adding the logarithm of the gain setting to the logarithm of the output voltage.

Automatic programming of frequency range, filter bandwidth and frequency scan rate are also provided on the 9300 B.

The frequency sweep generator is provided with a ramp mode of operation. In this mode the rate of change of scanning rate may be controlled manually or automatically.

The overall lack of compromise in this system indicates that the Honeywell 9300 B must give a very close approximation to the true mathematical functions it is designed to compute.

#### 9410 Time delay correlator system

Designed mainly for the analysis of signals above 50 c/s, the 9410 correlator is not considered suitable for the analysis of low frequency signals.

#### 3.8.5 Noratom - I.S.A.C.

An advantage of this instrument is its completeness. The price includes a specially designed tape recorder/reproducer and signal conditioning input filters. The tape reproducer has a maximum speed up ratio of 1024:1. The recorder can record for 4 hours 16 minutes.

Although ISAC can analyse in all three fundamental 'domains', it lacks flexibility in them all. In particular, in the frequency domain, Noratom have compromised to the extent of providing only one filter bandwidth of 1.5 c/s. This compromise places a very high restriction indeed upon the statistical uncertainty capabilities of the machine.

The machine can analyse 240 amplitude steps in 16 minutes, 400 time delay steps in 100 minutes and a 200 c/s bandwidth in 3 minutes 20 seconds. All of these analysis times are considered acceptable; the time delay channel being on the slow side.

### 3.8.6 Spectral Dynamics Corporation

The S.D.C. Mechanical Impedance System and Power Spectral density system are built from functional units which can all perform their individual functions away from the system.

Of the two systems the Mechanical Impedance system is the most highly developed. Both systems have been seen in operation and work fast and accurately. The initial setting up of the Mechanical Impedance system for a particular analysis took a great deal of time.

The sweep oscillator (Dynamic Analyser Timer) used in these systems has the unique facility of a tracking frequency multiplier and would be particularly useful in the harmonic analysis of engine excited vehicle vibrations.

Good specification points are a wide frequency range 2 - 25,000 c/s, a wide frequency sweep rate range 0.055 c/s/s - 20,000 c/s/s, a wide input signal range 1 mV - 1000V, the choice of a linear or logarithmic frequency sweep mode and the facility for slaving many additional filters to a single master filter. Automatic bandwidth switching is provided by the machine.

### 3.8.7 Technical Measurement Corporation

#### C.A.T. and C.O.R. Computers

The T.M.C. C.A.T. is unique in that it can compute the statistical properties of an ensemble of records at different times. Being a digital computer its accuracy is known, (8 bits) and its speed of computation is very high.

The C.A.T. coupled with the correlation computer performs a real time auto or cross correlation analysis with respect to time.

As a correlation computer the T.M.C. system is by far the most superior in terms of speed, it has a good time delay range, 163.84 seconds and a good range of delay increments 2.5 - 640 ms. Its frequency range is from 0 - 100 c/s making it an ideal correlator for the analysis of mechanical and bio-mechanical systems.

The sampling frequency of the C.A.T. can be varied in the range 0 - 100 c/s, the C.A.T. making 4 samples per cycle.

### 3.8.8 Technical Products Company

#### TP 625 Wave Analyser System

The TP 625 Wave Analyser system is by far the most flexible system in computation and adaptation. It is comprised of 6 basic functional units

each of which is fully self contained and capable of separate operation. Each of the 6 basic units can perform a wide range of functions.

Unique to TDL is a very flexible amplitude probability analyser, a number of units of which may be slaved together to perform higher order amplitude probability computations.

Although the TPC system lacks some of the refinements of other systems such as automatic bandwidth switching and frequency range programming, this is not regarded as a drawback.

Notable specification highlights are a wide frequency range, 2 - 30,000 c/s for frequency analysis, 0 - 9,000 c/s for amplitude analysis, a wide range of amplitude and frequency filters, the option of linear or logarithmic sweep rates with an infinitely variable scan rate range from 0.2 -  $20.10^9$  c/s/s, the option of true integration on RC averaging with a wide range of averaging time constants 0.1 - 100 seconds, a high dynamic range - 80 db crest signal to r.m.s. noise.

#### 4.0 Physical and Practical Considerations for the measurement analysis of time history records. (see table V).

##### 4.1 Description of Periodic Time history records

A time history record having a fundamental period of repetition may be completely described by amplitude, frequency and phase data. Equations (1) - (5) are the descriptive functions. Equation (5) may be approximated by discrete frequency spectrum analysis. The amplitude of the Fourier components defined in equation (5) may be detected by passing the periodic signal through a single filter heterodyne analyser or a contiguous filter analyser. In the case of the heterodyne analyser, the single filter is either stepped or swept through the frequency range of the Fourier components. The considerations to follow will apply only to the heterodyne analyser. The contiguous filter analyser is here ignored on the basis of capital cost and restricted application.

The amplitude domain of the discrete frequency spectrum may be described by the peak amplitude of the filter output, for sinusoidal Fourier components or by any one of the functions in equations (1) - (4).

##### 4.1.1 Measurement Analysis Accuracy

The accuracy with which periodic records may be described is as high as the basic measurement and calibration accuracy of the analysis equipment. With periodic records there is no further uncertainty with regard to statistical accuracy of the description since the waveform is deterministic.

#### 4.1.2 Measurement Resolution

Resolution is a direct function of the equivalent ideal noise bandwidth of the single heterodyne filter. A resolution criterion is given by the minimum bandwidth

$$B < \frac{1}{T_p} \text{ c/s} \quad T_p \text{ being the fundamental time period of the record.}$$

This criterion is based on the requirement that the analyser must be capable of detecting adjacent Fourier frequency components.

#### 4.1.3 Length of Time history record

A periodic time history record is completely described by the data contained in a record length of one time period.

##### Record looping

In the case of heterodyne discrete frequency spectrum analysers, the time history record may be made into a loop. Looping however may produce a false time period and introduce false frequency components unless the exact length of the loop is an even multiple of the record time period. This effect becomes insignificant if the loop length is greater than ten time periods.

∴ length criterion

$$T > 10.T_p.$$

#### 4.1.4 Averaging time

For average value detection of the signal after filtering, a true integrating circuit may be employed or a rectifying and smoothing circuit.

For the latter the R.C. time constant of the smoothing low pass filter must be greater than the time period of the record.

∴ minimum time constant  $K > T_p$ .

#### 4.1.5 Sweep as Scan Rate

There are two criteria for scan rate:

1) Scan rate based upon analyser filter response time,

i.e.  $S.R. < B^2 \text{ cps/sec.}$

i.e. the response time of a narrow band pass filter is generally less than

$1/B$  secs.  $B$  is the equivalent ideal noise bandwidth of the filter.

2. Scan rate based upon R.C. time constant of low pass filter.

$$SR < \frac{B}{4K} \text{ cps/sec.}$$

i.e. 98% of the steady state amplitude of a low pass filter is reached in the space of 4 time constants.

#### 4.1.6 Analysis Time

$$\text{Analysis time} = \frac{\text{Frequency range}}{\text{Scan rate}}$$

$$= \frac{F}{B^2} \text{ secs.}$$

$$\text{or} = \frac{4FK}{B} \text{ secs.}$$

### 4.2 Description of Weakly Stationary Random Time History Records

#### 4.2.1 Analysis accuracy

The functions which describe random time history records all involve a limiting process of integration as time (record length) approaches infinity. In the case of the amplitude domain a second limit is required as the amplitude window approaches zero. In the frequency domain the second limit is that the bandwidth should approach zero.

Real time history records are finite in length and real amplitude and frequency analysers have finite parameters. It is therefore only physically realisable to obtain measured estimates of the true descriptive functions defined by equation (6) onwards.

The difference in magnitude between the true (population) description of a random record and the measured estimate is the statistical uncertainty; a measure of which is given by the standard error  $\epsilon$ . (see Appendix 1).

Analysis accuracy for random records is still as high as the basic measurement and calibration accuracy of the analyser but has associated with it a statistical uncertainty due to a finite record length, amplitude window and filter bandwidth. Statistical uncertainty is conceptually different to measurement and calibration error.

#### 4.2.2 Description of a single random record in the amplitude domain

##### First order amplitude probability density function

An estimate of the true function given by equation (10) is obtained from:

$$\hat{P}(x) = \frac{1}{TW} \int_0^T tw \, dt \quad (92)$$

$t_w$  is the time spent in the amplitude window of width  $w$  volts.  $T$  is the record length in seconds.

The cap above  $p(x)$  denotes that  $p(x)$  is a measured estimate.

#### 4.2.2.1 Statistical uncertainty in first order A.P.D. measurements

For signals having a low frequency content where the bandwidth is narrow, the expected normalised variance in an A.P.D. measurement is given by:

$$\epsilon^2 = \frac{0.068}{\hat{p}(x) WT \overline{v}_0} \quad (93)$$

For signals having narrow bandwidths and a high centre frequency

$$\epsilon^2 = \frac{0.028}{\hat{p}(x) WB} \quad (94)$$

where  $\hat{p}(x)$  is the measured A.P.D.

$w$  is the amplitude gate width

$B$  is the equivalent ideal noise bandwidth of the record

$\overline{v}_0$  is the expected number of zero crossings per second.

$\overline{v}_0$  is a function of the mean square spectral density function  $G_x(f)$

$$\text{i.e.} \quad \overline{v}_0 = 2 \left\{ \frac{\int_0^\infty f^2 G_x(f) df}{\int_0^\infty G_x(f) df} \right\}^{\frac{1}{2}} \quad (95)$$

If the M.S.S.D. function is uniform between  $f_a$  and  $f_b$

$$\overline{v}_0 = 2 \left\{ \frac{fa^2 + fafb + fb^2}{3} \right\}^{\frac{1}{2}} \quad (96)$$

If the M.S.S.D. function is uniform down to zero frequency

$$\overline{v}_0 = 1.15 fb = 1.15B \quad (97)$$

For an M.S.S.D. function having a sharp peak at some centre frequency  $f_c$

$$\overline{v}_0 = 2fc \quad (98)$$



In general a good approximation to  $\epsilon^2$  for most records is given by:

$$\epsilon^2 = \frac{0.04}{\hat{p}(x)NBT} \quad (99)$$

Considering equation (99); for a given WBT value the normalised variance in an APD measurement varies according to the amplitude being measured, i.e. the value of  $\hat{p}(x)$  depends upon the value of the amplitudes being measured at any instant.

#### 4.2.2.2 Measurement resolution

Resolution is the ability of the analyser to properly define peaks in the amplitude probability density function.

Measurement resolution is proportional to amplitude gate width. Reducing the gate width increases resolution and increases the statistical uncertainty in the measurement. Amplitude gate width is therefore a compromise between:

- a) resolution
- b) statistical uncertainty.

#### Criterion for resolution

$$W < \frac{1}{4} x_{RMS}$$

$x_{RMS}$  is the R.M.S. value of the time history record.

#### 4.2.2.3 Length of record

The length of record limits the statistical accuracy of the measurement.

In order to limit statistical uncertainty to a pre-determined level the record length must first be defined to ensure that the sample time history record is sufficiently long.

#### 4.2.2.4 Averaging time

Two types of averaging are commonly used:

- a) Linear or true integration
- b) Low pass filter smoothing or R.C. averaging.

The first type of averaging gives a single estimate of the A.P.D. function at the end of the averaging or integration time  $T_a$ . R.C. averaging, however, gives a continuous measure of the A.P.D. function if the R.C. time constant is short compared to the record length  $T$ .

For the highest statistical accuracy  $T_a$  should be as long as  $T$ . If  $T_a$  is shorter than  $T$  the statistical uncertainty will increase.

For R.C. Averaging minimum statistical uncertainty is only achieved by making R.C. very long. In making R.C. =  $K$ , very long, however, the scan rate is reduced and the analysis time increased. A compromise between uncertainty and analysis time is given when  $K = T$ .

When  $K = T$  the continuous estimate of the A.P.D. function, at any time, will have approximately a standard error within  $\pm 4\%$  of that attainable from equation (99).

#### 4.2.2.5 Scan rate

In an A.P.D. analyser having a single amplitude gate the amplitude range of interest must be stepped or scanned.

For an analyser performing true integration:

$$SR < \frac{W}{T_a} \dots \frac{\text{volts}}{\text{sec.}}$$

where  $w$  is the amplitude gate width.

For an analyser having an R.C. averaging network, with a time constant  $K$  seconds

$$SR < \frac{W}{4K} \dots \frac{\text{volts}}{\text{sec.}}$$

#### 4.2.2.6 Analysis time

If  $A$  is the amplitude range of interest for an analyser performing true integration.

$$\text{Analysis time} = \frac{T_a \cdot A}{W} \text{ secs.}$$

For an R.C. averaging analyser

$$\text{Analysis time} = \frac{4KA}{W} \text{ secs.}$$

### 4.2.3 Description of a single random record in the time domain

#### Autocorrelation analysis

An estimate of the true autocorrelation function can be obtained from:

$$R_x^{\wedge}(\tau) = \frac{1}{T} \int_0^T x(t)x(t+\tau)dt \quad (100)$$

$\tau$  is the time delay between the record and a reproduction of itself.  
 $\tau$  is varied from zero to some upper limit and need not be negative.

#### 4.2.3.1 Statistical uncertainty

In terms of  $\epsilon$  the expected normalised variance in a measured estimate of  $R_X^{\wedge}(\tau)$  is given by:

$$\epsilon^2 = \frac{1}{BT} \quad (101)$$

this relationship holds only for values of  $\tau$  very much smaller than  $T$  and a  $B.T.$  product greater than an equal to ten.  $B$  is the equivalent ideal noise bandwidth of the record.

#### 4.2.3.2 Measurement resolution

The resolution of an autocorrelation analyser is defined by the interval between lag times. For a swept or stepping delay system the criterion for resolution based on practical considerations is:

$$h < \frac{1}{4B} \text{ secs.}$$

where  $h$  is the time interval between lag times and  $B$  is the equivalent ideal noise bandwidth of the record.

#### 4.2.3.3 Length of record

The record length is dictated by the allowable standard error in the measured estimate and is found from equation (101).

#### 4.2.3.4 Averaging time

For an analyser having a true integrating circuit, for the highest statistical accuracy in the measurement, the averaging time should equal the record length. Where R.C. averaging is employed, to compromise between statistical accuracy and analysis time, the R.C. time constant should be as long as the record length.

#### 4.2.3.5 Scan rate

In order to cover the range of lag times of interest the lag time must be swept or stepped.

In an analyser having a true integrating circuit:-

$$SR < \frac{1}{4BT_a} \text{ secs/sec.}$$

B is the equivalent ideal noise bandwidth of the record.

For analysers employing R.C. Averaging networks the

$$SR < \frac{1}{16BK} \text{ secs/sec.}$$

#### 4.2.3.6 Analysis time

If the maximum lag time is  $\tau_m$  seconds the analysis time for true integrating analysers and R.C. Averaging analysers respectively is given by:-

$$\text{Analysis time} = 4BT_a\tau_m$$

$$\text{and Analysis time} = 16BK\tau_m$$

#### 4.2.4 Description of a single random time history record in the frequency domain

An estimate of the true mean square spectral density function is given by:

$$G_x^{\wedge}(f) = \frac{1}{BT} \int_0^T x_B^2(t) dt \quad (102)$$

##### 4.2.4.1 Statistical uncertainty

In terms of the standard error  $\epsilon$  the expected normalised variance in a measured M.S.S.D. estimate is given by:

$$\epsilon^2 = \frac{1}{BT} \quad (103)$$

where B is the equivalent ideal noise bandwidth of the narrow bandpass filter or more precisely for that portion of the record spectrum within the frequency range of the bandpass filter. For an interpretation of  $\epsilon$  see Appendix 1.

##### 4.2.4.2 Measurement resolution

The resolution of an M.S.S.D. analyser is defined by its ability to detect sharp peaks in the spectrum of the input record. Resolution is proportional to filter bandwidth. Statistical uncertainty however is inversely proportional to filter bandwidth. A compromise for a resolution criterion is given by:

$$BW < \frac{1}{4}(f_2 - f_1) \text{ c/s.}$$

where  $(f_2 - f_1)$  is the bandwidth between the half power points (3db) of a power spectral density peak.

#### 4.2.4.3 Length of record

Record length is dictated by the allowable normalised variance in the measured estimate of the M.S.S.D. function and is computed from equation (103).

#### 4.2.4.4 Averaging time

As for autocorrelation analysis.

#### 4.2.4.5 Scan rate

The scan rate for M.S.S.D. analysers to cover the total frequency range of interest will depend upon the response time of the narrow bandpass filter. Scan rate is also dependent upon the averaging time. Too fast a scan rate could increase the statistical uncertainty in the measurement. To maintain the highest statistical accuracy the bandpass filter must not move its centre frequency faster than one filter bandwidth per record length. The scan rate for true integrating analysers and R.C. Averaging analysers based upon the two above considerations is therefore:

$$SR < \begin{cases} \frac{B}{T_a} \\ \frac{B^2}{8} \end{cases} \quad \text{whichever is the smaller..}$$

$$SR < \begin{cases} \frac{B}{4FK} \\ \frac{B^2}{8} \end{cases} \quad \text{whichever is the smaller}$$

#### 4.2.4.6 Analysis time

If the total frequency range of interest is  $F$  c/s, the analysis time for true integrating analysers and R.C. Averaging analysers is given by:-

$$\text{Analysis time} = \begin{cases} \frac{F T_a}{B} \\ \frac{8F}{B^2} \end{cases} \quad \text{whichever is the longer}$$

$$\text{Analysis time} = \begin{cases} \frac{4FK}{B} \\ \frac{8F}{B^2} \end{cases} \quad \text{whichever is the longer.}$$

#### 4.3 Description of a pair of random time history records

##### 4.3.1 Description in the amplitude domain

###### Joint amplitude probability density function

An estimate of the true joint A.P.D. function defined in equation (20) is given by:

$$\begin{aligned} p(\hat{x}, y) &= \frac{1}{T\Delta x\Delta y} \int_0^T t(x, x+\Delta x; y, y+\Delta y) dt \\ &= \frac{tw_x ; tw_y}{w_x w_y} \end{aligned} \quad (104)$$

##### 4.3.1.2 Statistical uncertainty

A relationship for the expected normalised variance in a measured estimate of the joint A.P.D. has not been evaluated. It can be said, however, that the value of  $\epsilon$  would be much greater for the joint A.P.D. than for the first order A.P.D.

##### 4.3.1.3 Measurement resolution. Length of Record. Averaging time.

These considerations are identical with those for the 1st order A.P.D.

##### 4.3.1.4 Scan rate

The scan rate for the joint A.P.D. analyser is the same as that for the single A.P.D. analyser except that the amplitude range of the one channel must be scanned for all the levels of amplitude of the other channel.

$$\therefore \text{SR} < \frac{W_x}{T_a} \quad \text{for } W_y \text{ fixed at } y \text{ volts.}$$

(True Int)

$$\text{or } \text{SR} < \frac{W}{4K} \quad \text{for } W_y \text{ fixed at } y \text{ volts.}$$

(RC Av.)

##### 4.3.1.5 Analysis time

If the maximum amplitude of interest in record x is  $A_x$  and in record y  $A_y$ .

$$\text{Analysis time} = \frac{T A_x A_y}{w_x w_y}$$

(True int.)

or

$$\text{Analysis time} = \frac{4K A_x A_y}{w_x w_y}$$

#### 4.3.2 Joint description in the time domain

##### Cross correlation analysis

An estimate of the true cross correlation function given in equation (21) is given by:

$$R_{xy}^{\wedge}(\tau) = \frac{1}{T} \int_0^T x(t)y(t+\tau)dt \quad (105)$$

##### 4.3.2.1 Statistical uncertainty

If the records  $x(t)$  and  $y(t)$  have nominally the same equivalent ideal noise bandwidth  $B$  c/s the expected normalised variance in a cross correlation measurement, in terms of  $\epsilon$  is given by:

$$\epsilon^2 = \frac{1}{BT}$$

For record pairs  $x(t)$  and  $y(t)$  having widely different equivalent ideal noise bandwidths the above relationship no longer applies. No uncertainty relationship for this case has been evaluated to date.

4.3.2.2 For considerations of resolution, record length, averaging time, scan rate and analysis time refer to the considerations for auto-correlation analysis.

#### 4.3.3 Joint description in the frequency domain

##### Cross spectral density analysis

An estimate of the true C.S.D. function defined in equations (24), (25) and (26) is given by:

$$G_{xy}^{\wedge}(f) = C_{xy}^{\wedge}(f) - jQ_{xy}^{\wedge}(f) \quad (106)$$

$$C_{xy}^{\wedge}(f) = \frac{1}{BT} \int_0^T x_B(f,t)y_B(f,t)dt \quad (107)$$

$$Q_{xy}^{\wedge}(f) = \frac{1}{BT} \int_0^T x_B(f,t)y_B(f,t)dt \quad (108)$$

B is the equivalent ideal noise bandwidth of that part of the records  $x(t)$  and  $y(t)$  passed by the pair of narrow bandpass filters of centre frequency  $f$  c/s.

#### 4.3.3.1 Statistical uncertainty

The individual standard errors associated with the real and imaginary parts of the C.S.D. function are approximately the same as that for M.S.S.D. analysis, i.e.

$$\epsilon^2 = \frac{1}{BT}$$

4.3.3.2 For considerations of resolution, record length, averaging time, scan rate and analysis time refer to section 4.2.4.



Appendix 1

Interpretation of  $\epsilon$

Consider a stationary random time history record having a true first order amplitude probability density function  $p(x)$ . If this time history record is sampled at different times and an estimate  $\hat{p}(x)$  computed for each sample it can be said that for 68% of the estimates obtained the difference between  $\hat{p}(x)$  and  $p(x)$  will be less than  $\pm \epsilon \hat{p}(x)$ . Stated conversely, we are 68% confident that the true value  $p(x)$  will be in the range  $(1 \pm \epsilon) \hat{p}(x)$ .

This concept of statistical uncertainty has the same interpretation for all descriptive functions of a random time history record.

For Auto-correlation functions if  $\epsilon$  is less than 0.30 there is 68% confidence that the true value of the auto-correlation function lies in the range  $(1 \pm \epsilon) R_x^{\wedge}(\tau)$ .

Table IV

Breakdown of price and functional capability for the TPC system of functional units

	<u>1st System</u>	<u>2nd System</u>
System complexity	Most complex system	
System price	£21,955 £25,811 with Noratom	£14,055
List of functional units required	3 - Probability analysers 2 - Analysers (frequency) 1 - Sweep oscillator 5 - Multipliers 1 - Potentiometer 2 - XY Plotters	2 - Probability analysers 2 - Frequency analysers 1 - Sweep oscillator 2 - Multipliers 1 - Potentiometer 2 - YX Plotters
List of functions plotted automatically (See Table 1)	A/1,3,5,6,7 B/1,2,4,5,6,7,8,11,12. C/1,2,3,4,7,8,9. D/3,4 E/1.	A/1,3,5,6,7. B/1,2,4,5,6,7,8,11,12 C/1,2,3,4,7,8,9. D/3
List of functions that can be manually plotted	A/2,4. B/3, C/10 F/1	A/2,4. B/3, C/10, D/4 F/1
List of functions that could be plotted with the addition of equipment manufactured by other concerns.	Add Noratom Tape Deck at £3,916 B/9,10. C/5,6.	

Table IV (Continued)

Breakdown of price and functional capability for the TPC system of functional units

<u>System complexity</u>	<u>3rd System</u>	<u>4th System</u>
<u>System price</u>	<u>£8,605</u>	<u>£5,865</u>
<u>List of functional units required</u>	1 - Probability analyser 2 - Frequency analysers 1 - Sweep oscillator 1 - Multiplier 1 - Potentiometer 1 - XY recorder	2 - Frequency analysers 1 - Sweep oscillator 1 - Multiplier 1 - Potentiometer 1 - XY recorder
<u>List of functions plotted automatically (see Table 1)</u>	A/1,3,5,6,7. B/1,2,4,5,6,7,8,11,12. D/3.	A/1,3,5,6,7. B/1,2,4,11,12. D/3.
<u>List of functions that can be manually plotted</u>	A/2,4. B/3. C/7,8,9,10. D/4. F/1.	A/2,4. B/3. C/7,8,9,10. D/4. F/1.

Table IV (Continued)

Breakdown of price and functional capability for the TPC system of functional units

System complexity	5th System	Least complex system
Price	£5,955	£3,215
List of functional units required	1 - Probability analyser 1 - Frequency analyser 1 - Sweep oscillator 1 - Potentiometer 1 - XY recorder	1 - Frequency analyser 1 - Sweep oscillator 1 - Potentiometer 1 - XY recorder
List of functions plotted automatically (see Table 1)	A/1,3,5,6,7. B/1,2,4,5,6,7,8,11,12	A/1,3,5,6,7. B/1,2,4,11,12.
List of functions that can be manually plotted	A/2,4. B/3. D/3.	A/2,4. B/3. D/3.

Table IV (Continued)

Spectral Dynamics Corporation

System complexity	Least complex system
System Price	£4,500
List of functional units required	1 - Frequency analyser 4 - Crystal filters 1 - Dynamic analyser tuner 1 - Lin/Lag sweep generator 1 - Averager 1 - XY plotter
List of functions plotted automatically	A/1,3,6,7. B/2,4,11,12.
List of functions that can be plotted manually	A/2,4. B/3. D/3.

Table IV (Continued)

Spectral Dynamics Corporation

System complexity	Most complex system	2nd system	3rd system
System price	£11,200	£9,055	£7,325
List of functional units required	1 - Mech. Imp. analyser 1 - Dynamic analyser tuner 1 - Lin/log sweep generator 2 - Multi-channel averagers 2 - XY recorders	1 - Mech. Imp. analyser 1 - XY recorder	2 - Frequency analysers 1 - Dynamic analyser tuner 1 - Lin/lag sweep generator 2 - Multi-channel XY recorders 8 - Crystal filters
List of functions plotted automatically (see table 1)	A/1,3,6,7. B/2,4,11,12. C/7. D/3,4. J/1,2.		A/1,3,6,7. B/2,4,11,12.
List of functions that can be plotted manually	A/2,4. B/3.	A/6,7. D/3,4. J/1,2.	A/2,4. B/3. D/3.



TABLE II  
LIST OF MAIN SPECIFICATIONS

DOMAIN	INFLUENCE CLASSIFICATION	SPECIFICATION ITEM	AD-TV AUTOMATIC MECHANICAL IMPEDANCE ANALYSER TYPE 1010	FENLOW AUTOMATIC ANALYSER	CULACH INDUSTRIES WAVE ANALYSER TYPE GR - 14/4	CULACH INDUSTRIES TRANSMISSIBILITY RATIO PLOTTER, TYPE GP - 1	CULACH INDUSTRIES TRANSFER FUNCTION ANALYSER TYPE GP - 3	HENYRELL 9300 SERIES SPECTRUM ANALYSER AND 9410 CORRELATOR	ROKACOM - INSTRUMENT FOR STATISTICAL ANALOGUE COMPUTATIONS	SPECTRAL DYNAMICS CORPORATION - ANALYSERS	TECHNICAL BRASHERS/ CORPORATION - C.L.T.	TECHNICAL PRODUCTS COMPANY - 603 WAVE ANALYSER SYSTEM	
Amplitude	Performance and Operation	Function(s) computed							1st order amplitude probability distribution		1st order amplitude prob. distribution and amplitude prob. density	Probability density, probability distribution, Rayleigh distribution.	
		Mode of computation							Off-line, analogue		On-line digital	Off-line analogue/digital	
		Input signal range							± 2.5 V		+ 10 V	Nominally 1 V R.M.S.	
		Pre-amplifier gain							Not known		Not known	Amplified signals below 0.02 V R.M.S. (not known)	
		Input impedance							1 meg OHM		33,000 OHMS	100 K OHMS	
		Data frequency range							0 - 200 cps		0 - 100 cps	0 - 5 K cps	
		Number of amplitude filters							60 or 240		200 pW - 10 V indefinitely variable	50	
		Amplitude range							Not known		Not known	± 5 sigma, adjustable to ± 1 sigma	
	Output type							Analogue voltage to X.Y. plotter		Not known		Read out meters plus analogue and digital output channels	
	Measurement accuracy, resolution and statistical uncertainty.	Measurement accuracy							Better than 1%		± 1 in 512 (8 bits)	Not known	
		Gate width or amplitude resolution							0.0202 V or 0.0832 V		Infinitely variable	Minimum 0.33 sigma Maximum 0.023 sigma	
		Averaging type							True integral		True average	True integral or RT averaging	
		Averaging time constant							Not known RC = 1.32 secs.		Not known	Integrator constant 10 <sup>3</sup> secs. RC = 0.1 - 100 secs.	
		Averaging time							Maximum 4 hours		Not restricted	Not restricted	
		Amplitude range swept or stepped.							Stepped		Manually stepped	Stepped	
		Record length control							Provided on the magnetic tape loop		Not known	Externally by magnetic tape loop	
		Step or sweep rates							One window per 4 or 14 secs.				Step controlled
		Time	Performance and Operation	Function computed						True auto and cross correlation function	True auto and cross correlation function	ensemble auto and cross correlation function	
Mode of computation									Off-line analogue	Off-line analogue	On-line digital		
Input signal range								± 16 V	± 2.5 V		+ 5 V with respect to common conductor. + 500 V DC		
Pre-amplifier gain								None	Not known		None		
Input impedance								500 K OHM shunted 100pF	1 meg OHM		20 K OHM		
Data frequency range								50 - 250 K cps	0 - 200 cps		0 - 100 cps		
Number of correlation points								Infinitely variable	100 or 400		32 - 256		
Time delay range								47 ns	337.68 secs		163.44 secs		
Output type							Meter for correlation coefficients + X.Y. plotter	Analogue X.Y. plotter voltages		Digital/analog, X.Y. plotter & punched tape outputs.			
Measurement accuracy, resolution and statistical uncertainty	Measurement accuracy							2%	Better than 1%		Better than 0.1%		
	Delay increments (τ)							Swept	0.80 ms - 3475.8 ms		2.3 ms - 640 ms		
	Averaging type							R.C. averaging	True integral		True average		
	Averaging time						Maximum 20 secs.	Up to 4 hours		Not restricted			
Averaging time constant						0.2, 1.0, 5, 20 secs	Not known (RC = 1.32)		None				
Step or sweep?						Sweep or manual step	Step		Continuous real time				
Step or sweep rate						17 ms/min - 17ms/200 min.	One correlation point per 15 secs.		Not known				
Record length control						External on magnetic tape.	Provided on magnetic tape loop		By phase locked starting pulse.				



**TABLE III**  
Showing the Minimum Cost to perform Individual Analyses

Descriptive Function	Designate	Ad-Yu	Fenlow	Gulton I	Gulton II	Gulton III	Honeywell	Noratom	Spec.Dynam.	T.M.C.	T.P.C.
Mean Value	A1			£5000		£10-12,000	£15000app.		£233	£4466	£3215
Variance Value	A2										£3215
Mean square value	A3			£5000		£10-12,000	£15000app.				£3215
R.M.S.Value	A4								Not Known		£3215
Peak value	A5			£5000	£9000	£10-12,000	£15000app.			£4580	£3215
Fourier Series	A6		£1600	£5000	£9000	£10-12,000	£15000app	£4446	£4280		£3215
Fourier Integral	A7		£1600	£5000	£9000	£10-12,000	£15000app	£4446	£4280		£3215
Peak Value	B1			£5000	£9000	£10-12,000	£15000app			£4580	£3215
Mean value estimate	B2			£5000		£10-12,000	£15000app		£4280	£4466	£3215
Variance value estimate	B3										£3215
Mean square value estimate	B4		£1600	£5000		£10-12,000	£15000app	£4446	£4280		£3215
1st Order Amp.Prob. Dist.	B5									£4580	£3730
1st Order Amp. Prob. Density	B6							£4028		£4617	£3730
Rayleigh Distribution	B7										£5860
Normalised Amp. Prob. Functions	B8									£4580	£3730
Autocorrelation Function	B9										
Correlation Coefficient	B10						£2078	£4237		£7495	£2710+delay
Mean square spectral function	B11	£4500 app		£5000		£10-12,000	£2078	£4237		£7495	£2710+delay
Unnormalised M.S.S.D. function	B12		£1600					£4446	£5430		£3215
2nd Order Amp. Prob. Dist.	C1										£6470
2nd Order Amp. Prob. Density	C2										£6470
2nd Order Rayleigh Distribution	C3										£9415
2nd Order Normalised functions	C4										£6470, 9415
Cross Correlation function	C5						£2078	£4237		£7495	£2710+delay
Cross Correlation Coefficient	C6						£2078	£4237		£7495	£2710+delay
Cross M.S.S.D. function	C7					£10-12,000	£15-18,000		£8350		£6975
----- Co Spectrum	C8	£4500 app				£10-12,000	£15-18,000		£8350		£4265
----- Quad Spectrum	C9	£4500 app				£10-12,000	£15-18,000		£8350		£4265
Coherence function	C10					£10-12,000					£13,735
Non Complex Transfer function	D1										-----
Complex Transfer function	D2										-----
Non Complex Frequency Response	D3	£4500 app.	£1600 +	£5000	£9000	£10-12000	£15-18000	£5637 +	£8350 +		£3215
Complex Frequency Response	D4	£4500 app.			£9000	£10-12000	£15-18000		£8350 +		£4265
3rd & higher Amp. Prob.functions	E1										£9210
3rd & higher Order Correl.funcs.	E2										
Multiple Coherence functions	F1					£10-12000					£4265 +
Multiple Correlation functions	F2										
Ensemble Mean value	G1									£4466	
Ensemble variance value	G2										
Ensemble Mean Square value	G3										
Ensemble 1st Ord.Amp. Prob.Dist.	G4									£4580	
Ensemble 1st Ord. Amp.Prob.Dens.	G5									£4617	
Ensemble 1st Order Rayleigh Dist	G6										
Ensemble 1st Ord.Norm.Dist.	G7										
Ensemble Covariance function	G8										
Ensemble Autocorrelation function	G9										
Ensemble Correlation Coefficient	G10										
Ensemble M.S.S.D. function	G11										
2nd Order Prob Functions	H1										
Cross Covariance & Correl.funcs.	H2										
Cross Spectral function	H3										
N.S. Amp. Prob. Functions	I1									£4617	
N.S. Correlation Functions	I2										
N.S. Spectral Density Functions	I3										
Mechanical Impedance	J1	£4500 app							£9050		Not known
Mobility etc.	J2	£4500 app							£9050		Not known

Note, Cost includes X Y Plotters or Teleprinters

Table V

Summary of practical considerations for the measurement analysis of time history records

Descriptive Functions Considerations	Periodic Data Fourier Analysis etc.	Weakly Stationary Random Time History Records (length of record(s) = T secs.)					
		Single time history record			Pair of time history records		
		D O M A I N			D O M A I N		
		Amplitude	Time	Frequency	Amplitude	Time	Frequency
1st Order Amp. Prob. Density Function	Auto-correlation Function	Mean Square Spectral Density Function	Joint Amplitude Probability Density Function	Cross Correlation Function	Cross Spectral Density Function		
Measurement analysis Accuracy (Errors)	Basic Measurement + Calibration Errors	Basic Measurement + Calibration Errors	Basic Measurement + Calibration Errors	Basic Measurement + Calibration Errors	Basic Measurement + Calibration Errors	Basic Measurement + Calibration Errors	Basic Measurement + Calibration Errors
Statistical Uncertainty (ε)	None	$\epsilon^2 = \frac{0.068}{\hat{p}(x)WBT}$ or $\epsilon^2 = \frac{0.028}{\hat{p}(x)WBT}$	$\epsilon^2 = \frac{1}{BT}$ B is record noise BW	$\epsilon^2 = \frac{1}{BT}$ B is filter noise BW	Not evaluated. Very much greater than $\epsilon^2 = \frac{0.04}{\hat{p}(x)WBT}$	For x(t) and y(t) both having record noise BW = B c/s $\epsilon^2 = 1/BT$ not evaluated for other cases	The individual uncertainties of $\hat{C}_{xy}(f)$ and $\hat{Q}_{xy}(f)$ are $\epsilon^2 = 1/BT$
Measurement Resolution Criterion	Filter Bandwidth $B < \frac{1}{T_p}$ c/s	Amplitude Filter $W < \frac{1}{4} x_{rms}$	Time Delay h secs. $h < \frac{1}{4B}$ secs. B is record noise BW	Filter Bandwidth $B_y < \frac{1}{4}(f_2 - f_1)$ ( $f_2 - f_1$ ) is spectral peak	Amplitude Filters $W_x < \frac{1}{4} x_{rms}$ $W_y < \frac{1}{4} y_{rms}$	Time Delay $h < \frac{1}{4B}$ secs. whichever BW is the smaller	Filter Bandwidth $B_{wx} = B_{wy} < \frac{1}{4}(f_2 - f_1)$
Length of Record	$T > 10T_p$	From $\epsilon^2 = \frac{0.04}{\hat{p}(x)WBT}$	From $\epsilon^2 = \frac{1}{BT}$	From $\epsilon^2 = \frac{1}{BT}$	Not exactly calculable. Much greater than from: $\epsilon^2 = \frac{0.04}{\hat{p}(x)WBT}$	From $\epsilon^2 = 1/BT$ for equal bandwidths. Not calculable for other cases.	From $\epsilon^2 = \frac{1}{BT}$
Averaging Time	For RC Averaging $K > T_p$	For true Int. $T_a = T$ For RC Averaging $K = T$	For true Int. $T_a = T$ For RC Averaging $K = T$	For true Int. $T_a = T$ For RC Averaging $K = T$	For true Int. $T_a = T$ For RC Averaging $K = T$	For true Int. $T_a = T$ For RC Averaging $K = T$	For true Int. $T_a = T$ For RC Averaging $K = T$
Sweep or Scan Rate	$SR < B^2 \frac{g/s}{sec.}$ or $SR < \frac{B}{4K} \frac{c/s}{sec.}$	$SR < \frac{W}{T_a} \frac{volts}{sec.}$ or $SR < \frac{W}{4K} \frac{volts}{sec.}$	$SR < \frac{1}{4BT_a} \frac{sec}{sec}$ or $SR < \frac{1}{16BK} \frac{sec}{sec}$	$SR < \begin{cases} B/T_a \\ B^2/8 \end{cases}$ whichever is the smaller or $SR < \begin{cases} B/4K \\ B^2/8 \end{cases}$	$SR < \frac{W_x}{T_a}$ with $W_y$ fixed at y volts or $SR < \frac{W_y}{4K}$ with $W_x$ fixed at x volts	$SR < \frac{1}{4BT_a} \frac{sec}{sec.}$ or $SR < \frac{1}{16BK} \frac{sec}{sec.}$ whichever BW is smaller	$SR < \begin{cases} B/T_a \\ B^2/8 \end{cases}$ whichever is the smaller or $SR < \begin{cases} B/4K \\ B^2/8 \end{cases}$
Analysis Time	$t = \frac{F}{B^2} \text{ secs.}$ or $t = \frac{4FK}{B} \text{ secs.}$	$t = \frac{T_a A}{W} \text{ secs.}$ or $t = \frac{4KA}{W} \text{ secs.}$	$t = 4BT_a T_m \text{ secs.}$ or $t = 16BK T_m \text{ secs.}$	$t = \begin{cases} \frac{FT_a}{B} \\ \frac{4FK}{B^2} \end{cases}$ whichever is the larger or $t = \begin{cases} \frac{4KA}{W} \\ \frac{4FK}{B^2} \end{cases}$	$t = \frac{T_a A X Y}{W_x W_y}$ or $t = \frac{4KA X Y}{W W_y}$	$t = 4BT_a T_m \text{ secs.}$ or $t = 16BK T_m \text{ secs.}$	$t = \begin{cases} \frac{FT_a}{B} \\ \frac{4FK}{B^2} \end{cases}$ whichever is the larger or $t = \begin{cases} \frac{4KA}{W} \\ \frac{4FK}{B^2} \end{cases}$

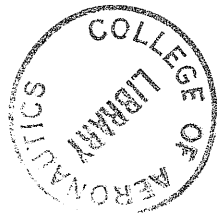

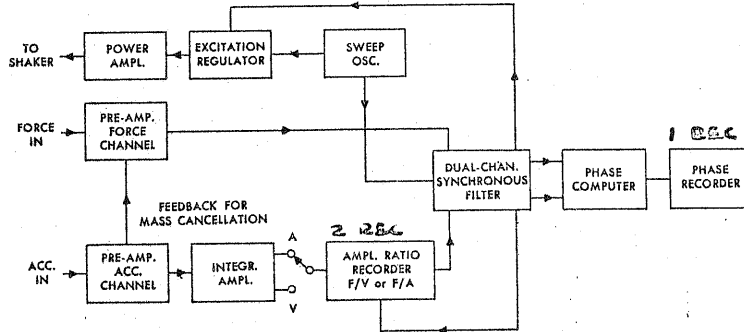

—Arrangement of Type 1010 System for measuring mechanical impedance. Two curves are automatically plotted by the system, one for mechanical admittance  $V/F$  or apparent phase  $A/F$ , and the other for phase angle between  $V$  and  $F$  or  $A$  and  $F$  as the frequency sweeps from 10 cps to 10 kc.

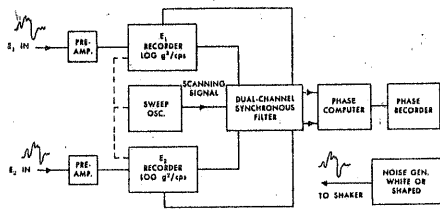

—Arrangement for dual-channel spectral density analysis.

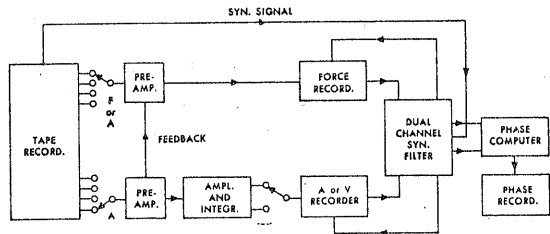

—Analyzing data recorded on tape for acceleration, force, vibration, etc.

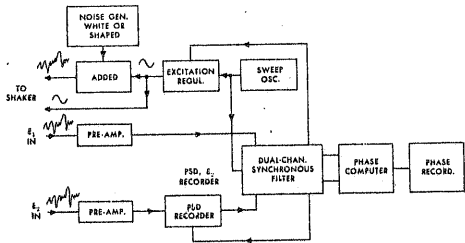

—Recording  $\text{LOG } g^2/\text{eps}$  curve with sinusoidal excitation, or mixed signal excitation.

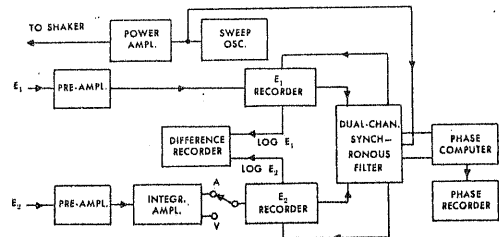

—Plotting complex ratio, transfer function, or correlation between  $E_1$  and  $E_2$ .

**FIG. 1. AD YU TYPE 1010 AUTOMATIC ANALYSIS SYSTEM.**

TABLE II CONTINUED

Frequency	Performance and operation	Functions computed	Mean square spectral density function for two time records	Mean square spectral density function for a single time record	Mean square spectral density function for a single time record	-----	Mean square spectral density function for two time records	Mean Square Spectral density function for two time records	Mean square spectral density function for a single record.	Measure spectral density function for a single record.	Mean square spectral density function for two time records.	
		Functions computed	Dual channel phase data			Non complex frequency response function (transmissibility)	Co-spectrum Quad spectrum Coherence function	Co-spectrum Quad. spectrum.			Co-spectrum Quad. spectrum Coherence function.	
		Mode of computation	Off-line analogue	Off-line analogue	Off-line analogue	Off-line analogue	Off-line analogue	Off-line analogue.	Off-line analogue	Off-line analogue	Off-line analogue	
		Input signal range	5 micro V - 50 V R.M.S.	$\pm 1$ V - $\pm 50$ V	0.036 - 36 V R.M.S.	0.036 - 36 V R.M.S.	0.036 - 36 V R.M.S.	100mV - 10V R.M.S. full scale	$\pm 2.5$ V	1mV - 1000V	0.1V - 10V R.M.S.	
		Pre-amplifier gain	60 db, 40 db, 20 db for both channels	0.5 - 4.0	Not known	Not known	Not known	Not known	Not known	Not known	10db steps from 0.1V - 10V R.M.S.	
		Input impedance	Not known	100 K OHM	1 meg OHM	1 meg OHM	1 meg OHM	100K OHM shunted 100pF	1 meg OHM	1 meg OHM	1 meg OHM in parallel with 100pF	
		Data frequency range	50/s - 10,000 c/s	0.3 c/s - 1K c/s	3 - 30,000 c/s	3 - 30,000 c/s	3 - 30,000 c/s	2 - 40,000 c/s	0 - 200 c/s	2 - 25,000 c/s	2 - 30,000 c/s	
		Number of channels	2	1	1	2	3	2	3	Not restricted	Not restricted	
		Dynamic range	80 db, 10 c/s - 10 Kc/s	not known	60 db	60 db	60 db for Co & Quad spectrum.	60db	Not known	60db	80db crest signal to R.M.S. noise ratio.	
		Crest factor	Not known	Not known	Not known	Not known	Not known	10 db	not known	4 to 1 at full input	Can be calibrated for any signal crest factor.	
		Output type	Strip chart recorders	On meter and X Y recorder	On X Y recorder, 0 - 100V	On X Y recorder $\pm 50$ V single ended	On X Y recorders $\pm 100$ V single ended	On X Y recorder	On X Y recorder	On X Y recorder 0 - 1.0V into 100K OHM	On X Y recorder digital outputs also provided.	
	Measurement accuracy, Resolution and Statistical uncertainty.	Measurement accuracy	Better than 1%	Not known	$\pm 2\%$ , 3 - 30,000 c/s	$\pm 2\%$ , 3 - 30,000 c/s	$\pm 2\%$ , 3 - 30,000 c/s	5% of reading $\pm 0.05\%$ of full scale	Better than 1%	Not known	Within 5% from 2 - 30,00 c/s	
		Filter type	Not known	Low pass active, zero i.f.	Low pass active, zero i.f.	Low pass active, zero i.f.	Low pass active, zero i.f.	Crystal band pass	Mechanical band pass	Crystal band pass	Quartz crystal lattice band pass	
		Filter Bandwidth (s)	-3db-- 2.0, 5.0, 10.0, & 50.0 c/s	-3db-- 0.06, 0.3, 1.5, 7.5 & 37.5 c/s	-3db-- 0.4, 0.5, 1.0, 2.0, 5.0, 10, 20, 25, 50, 75, 100, 150 c/s	As per OR-WA/1 analyser	As per OR-WA/1 analyser	1.0, 2.5, 10, 20 & 100 c/s	1.5c/s	2.0, 5, 10, 20 & 50 c/s	1.0, 2.5, 5, 10, 25, 50, 85, & 100 c/s (not -3db bandwidth)	
		Filter shape factor	Not known	Not known	Greater than 2.8	Greater than 2.8	Greater than 2.8	Better than 10 to 1	Not known	Nominally 4 to 1	Better than 4 to 1	
		Filter amplitude match (for cross spectrum analysers)	$\pm \frac{1}{2}$ db over 80 db range	None	$\pm 1$ db	$\pm 1$ db	$\pm 1$ db	Not known	None	Not known	Within 5%, 2 - 30,000 c/s	
		Filter phase match	$\pm \frac{1}{2}$ degree relative $\pm 1$ degree absolute	None	Within $\pm 1$ degree.	Within $\pm 1$ degree.	Within $\pm 1$ degree.	Not known	None	Not known	Within 1 degree 2 - 30,000 c/s	
		Filter time constant	Not known	Not known	Not known	Not known	Not known	Not known	Not known	Not known	Not known	
		Averaging type	Not known	RC averaging	True integral or RC averaging	True integral or RC averaging	True integral or RC averaging	True integration or RC averaging	RC averaging	True integration or Artificial integration using logarithms.	True integration or RC averaging	
		Averaging time	Not known	Not restricted	Not restricted	Not restricted	Not restricted	Not restricted	Up to 4 hours	Not known	Not restricted	
		Averaging time constant	Not known	2 & 15 secs	0.1, 0.2, 0.5, 1.0, 2.0, 5, 10, 20, 25, 50 or 100 seconds	As per OR-WA/1	As per OR-WA/1	Not known	2, 5, 10, 20 secs	Not known	0.1 - 100 secs infinitely variable	
		Step or sweep?	Sweep	Sweep	Sweep	Sweep	Sweep	Step or sweep	Sweep	Sweep	Sweep	
		Sweep rate range	0.925 - 27.8 c/s/s	$9.06 \times 10^{-3} - 1.42$ c/s/s	Linear rate 12.5 c/s/s - 3000 c/s/s	Linear rate 12.5 c/s/s - 3000 c/s/s	Linear rate 12.5 c/s/s - 3000 c/s/s	Not restricted 40 - 4000 c/s/s	0.05, 0.1, 0.2, 0.5, 1.0 c/s/s	Linear or log rate 0.05 - 20,000 c/s/s	Linear or log rate 0.2 - $20 \times 10^3$ c/s/s	
		Record length control	Externally on magnetic tape	Externally on magnetic tape	Externally on magnetic tape	Externally on magnetic tape	Externally on magnetic tape	Externally on magnetic tape or by integrator control	Provided on magnetic tape loop	Externally on magnetic tape	Externally on magnetic tape	
		Tape speed up ratio needed to analyse signals down to 0.1 c/s	50 - 100:1	3:1	30:1	30:1	30:1	20:1	None	20:1 for frequency analysis	None or amplitude analysis. 20:1 for frequency analysis	
Notion/Force Analysis	Performance and Operation	Frequency range	5 - 10,000 c/s							10 - 10,000 c/s		
		Dynamic range	80db unswitched 140db switched							140db		
		Amplitude response time	Not known							60db/sec		
		Impedance head mass cancellation?	Yes							Yes		
		Input signal range	5 micro V - 50 V R.M.S.							1 mV - 3.16 V R.M.S. 100 mV - 316 V R.M.S.		
		Input impedance	Not known							11 meg OHM		
		Filter type and bandwidth	Not known 2, 5, 10, 50 c/s							Crystal bandpass 2, 5, 20, 50, 100 c/s		
		Phase range	0 - 359.5°							0 - 360°		
		Phase accuracy	$\pm \frac{1}{2}$ ° relative $\pm 1$ ° absolute							$\pm 2\%$ over full dynamic range & frequency range		
		MAKER	Ad To Automatic analyser Type 1010	Penlow Automatic spectrum analyser	Gulton Industries Wave analyser OR-WA/1	Gulton Industries Transmissibility analyser GP-1	Gulton Industries Transfer function analyser GP-3	Honeywell Series 9300 automatic spectrum analyser	Norton - Instrument for statistical analogue computations	Spectral dynamics Corporation analysers	Technical measurement Corporation Series 625 C.A.T. & C.O.R.	Technical Products Company Series 625 Wave analyser system

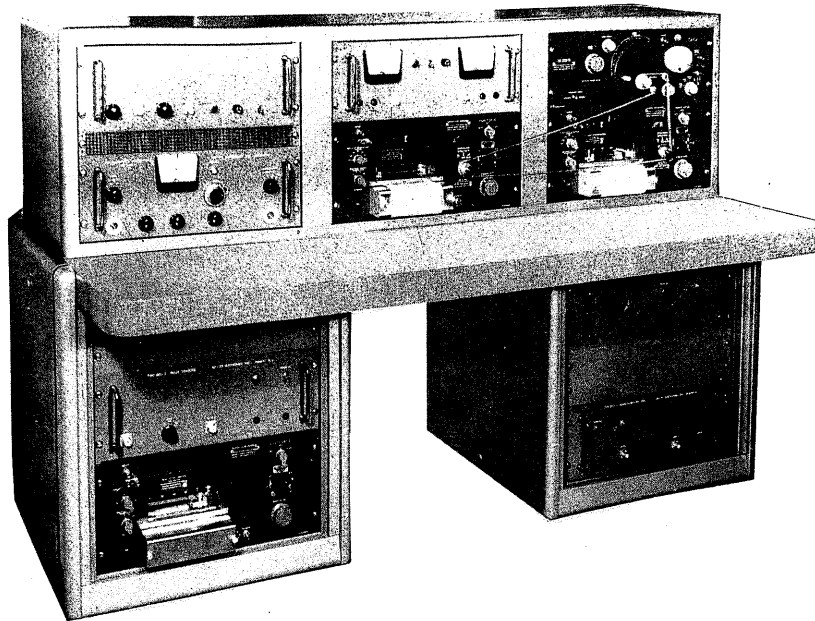

FIG 1 AD YU TYPE 1010 SYSTEM.

L.F. SPECTRUM ANALYSER  
0.3 c/s-1K/c/s

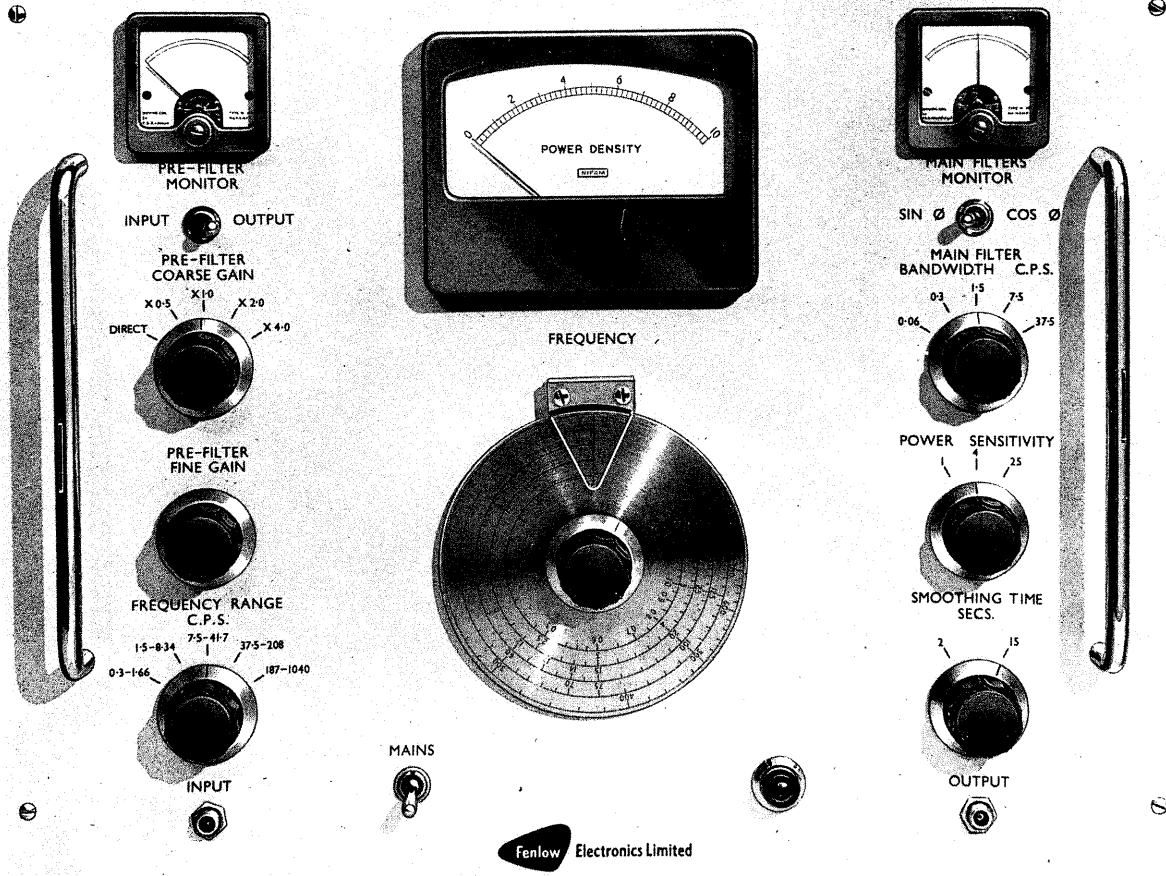

FIG 2 FENLOW ANALYSER.

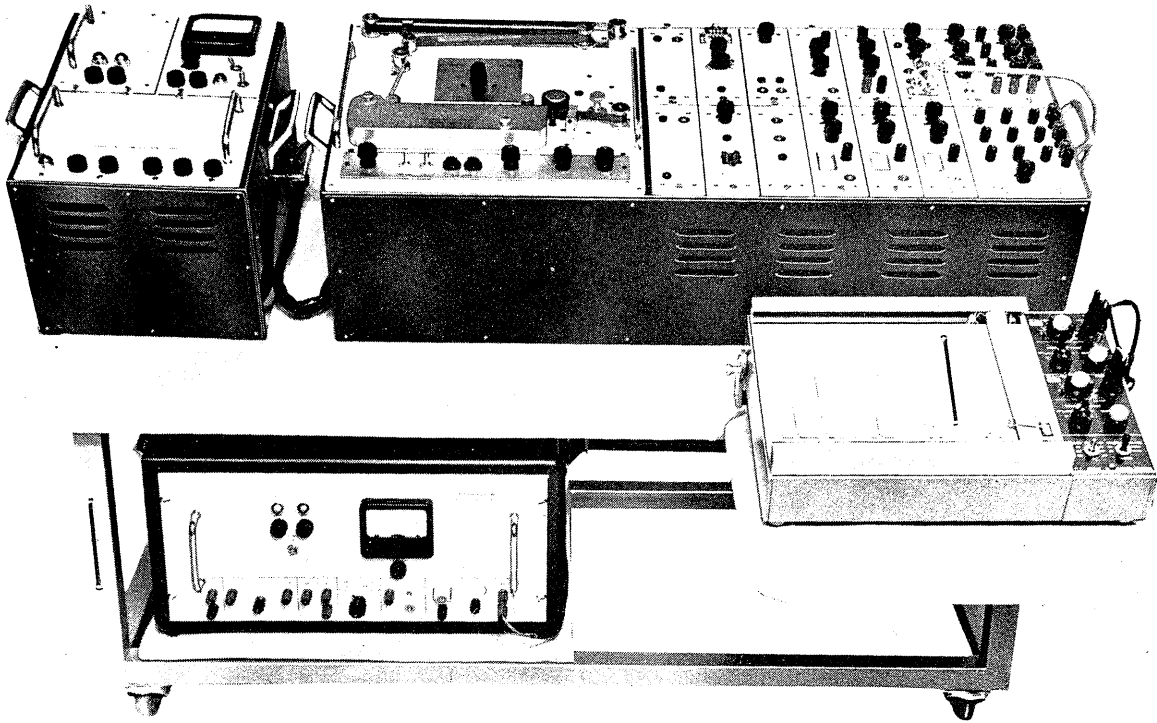

FIG 10 NORATOM I.S.A.C.

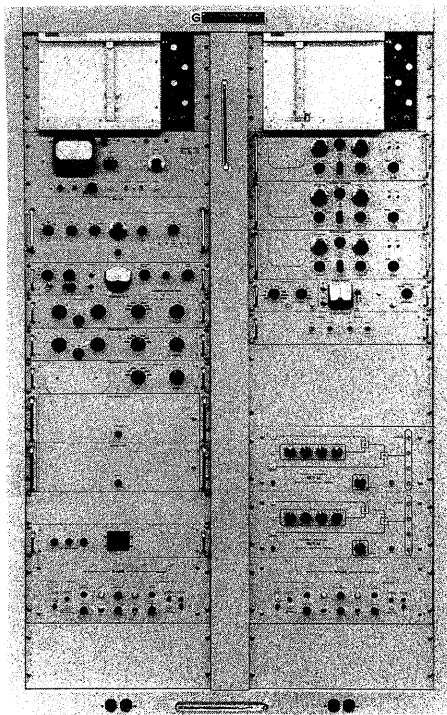
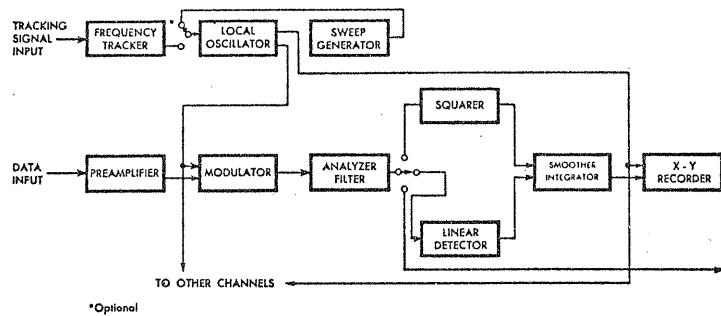
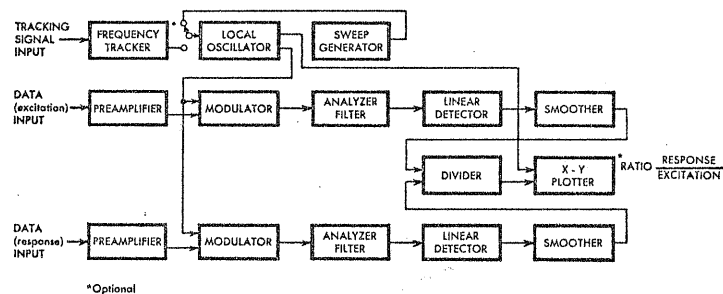

FIG 3 GULTON OF-3  
TRANSFER FUNCTION ANALYSER.



GENERAL ORTHOLOG MODEL OR-WA/1 WAVE ANALYZER SYSTEM



ORTHOLOG MODEL OTP/1 TRANSMISSIBILITY RATIO PLOTTER SYSTEM

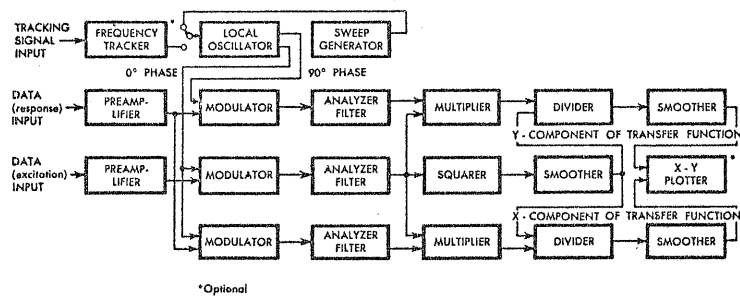

ORTHOLOG MODEL OF-3 TRANSFER FUNCTION ANALYZER SYSTEM

**FIG. 4 GULTON INDUSTRIES ORTHOLOG SYSTEM.**

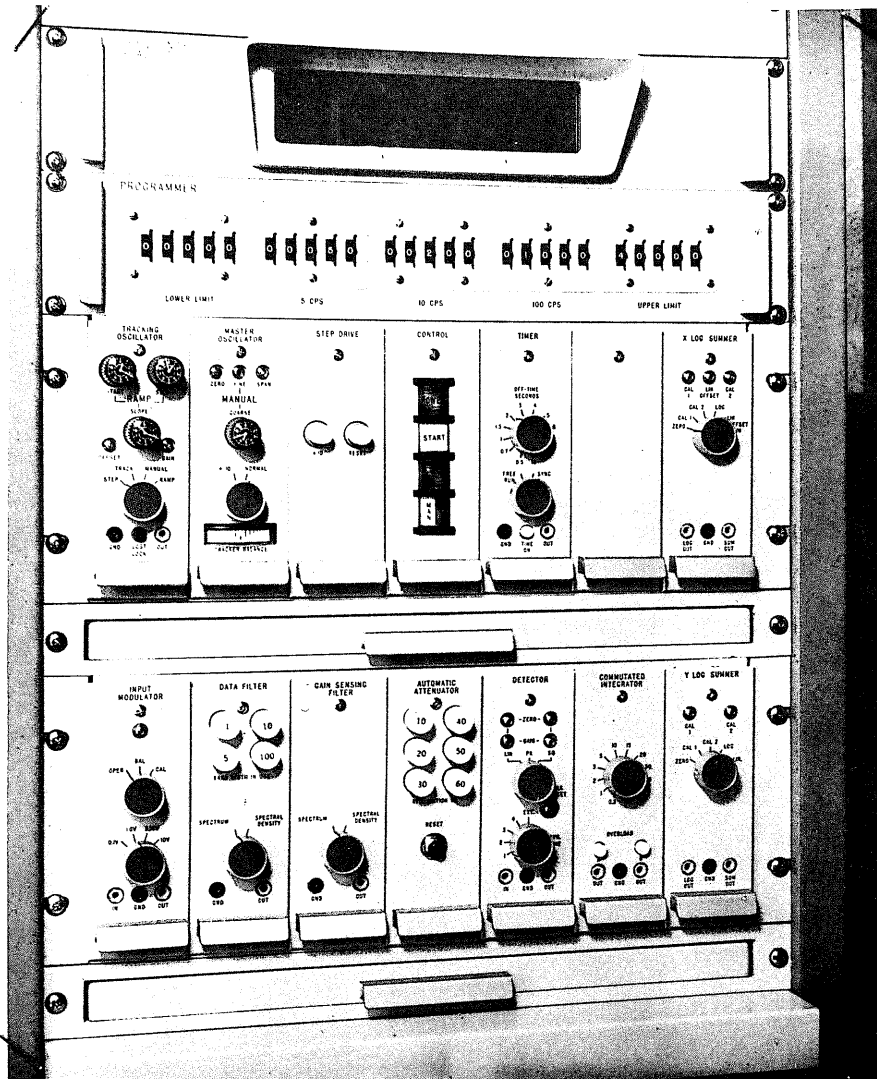

FIG 6 HONEYWELL 9300 B SYSTEM.

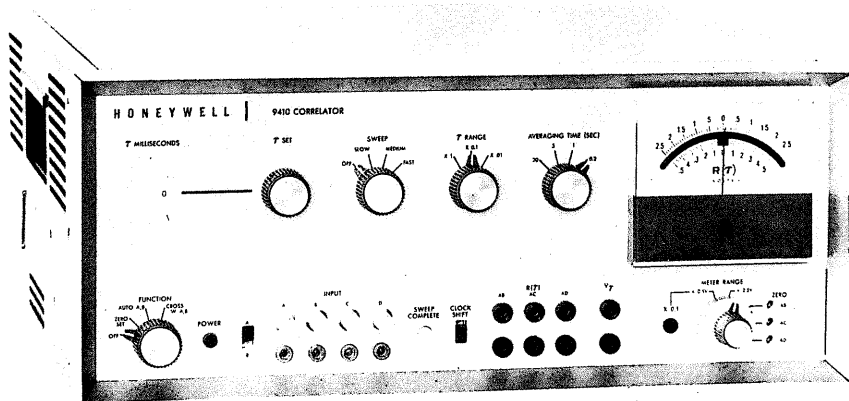
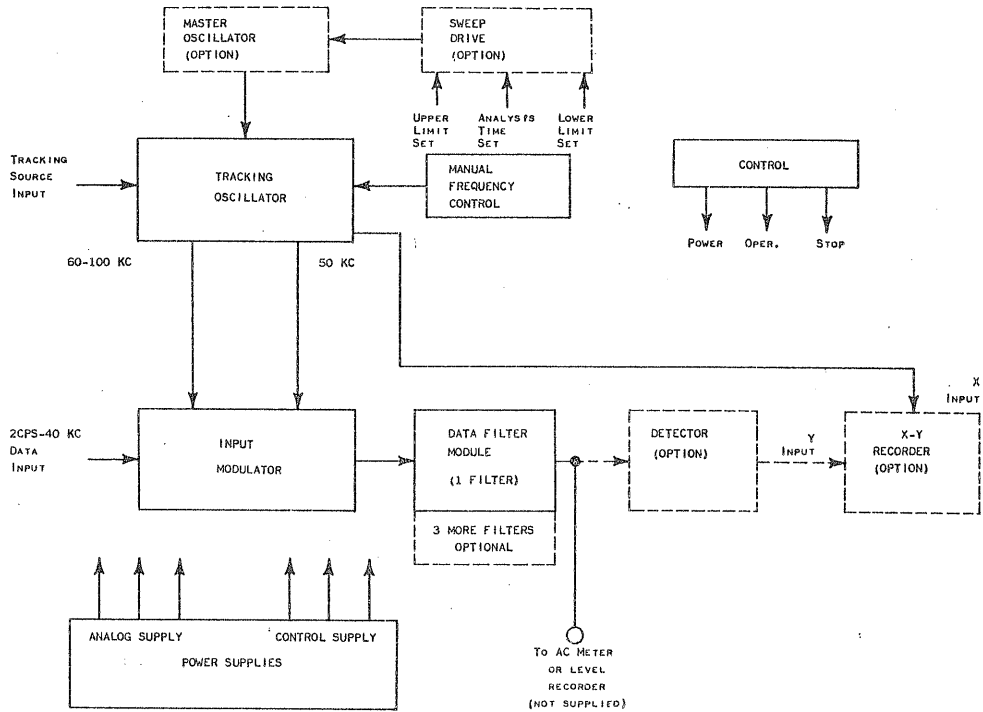
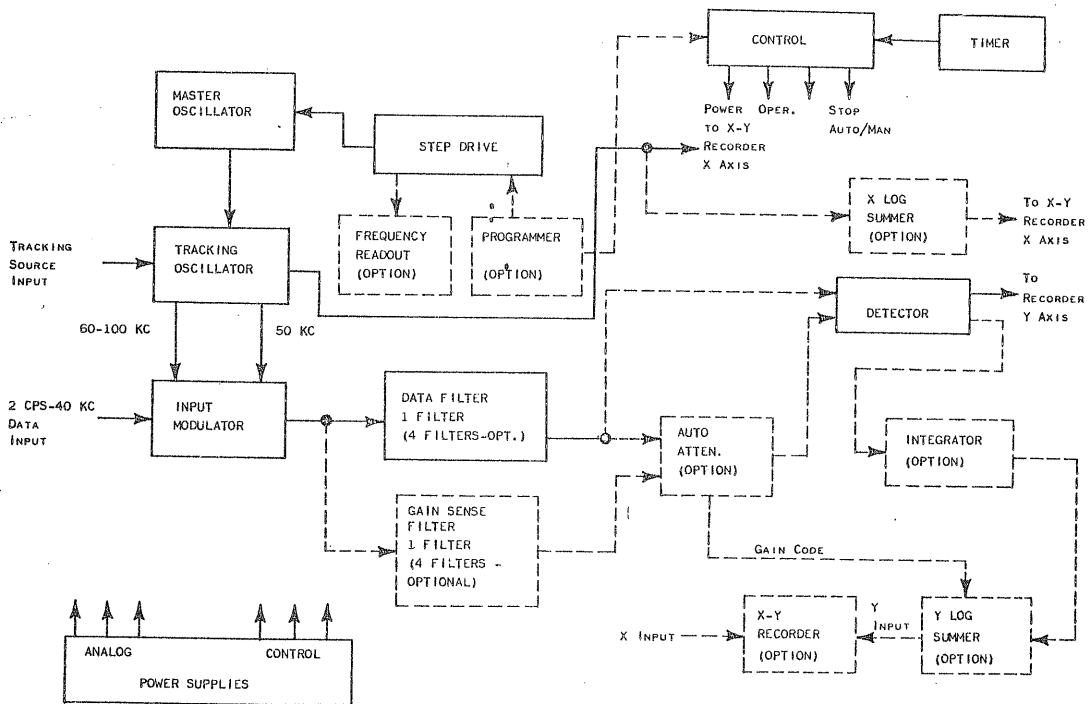

FIG 5 HONEYWELL 9410 CORRELATOR.





TYPICAL 9300 A BLOCK DIAGRAM



TYPICAL 9300 B BLOCK DIAGRAM

FIG. 6 & 7. HONEYWELL SERIES 9300 ANALYSERS.

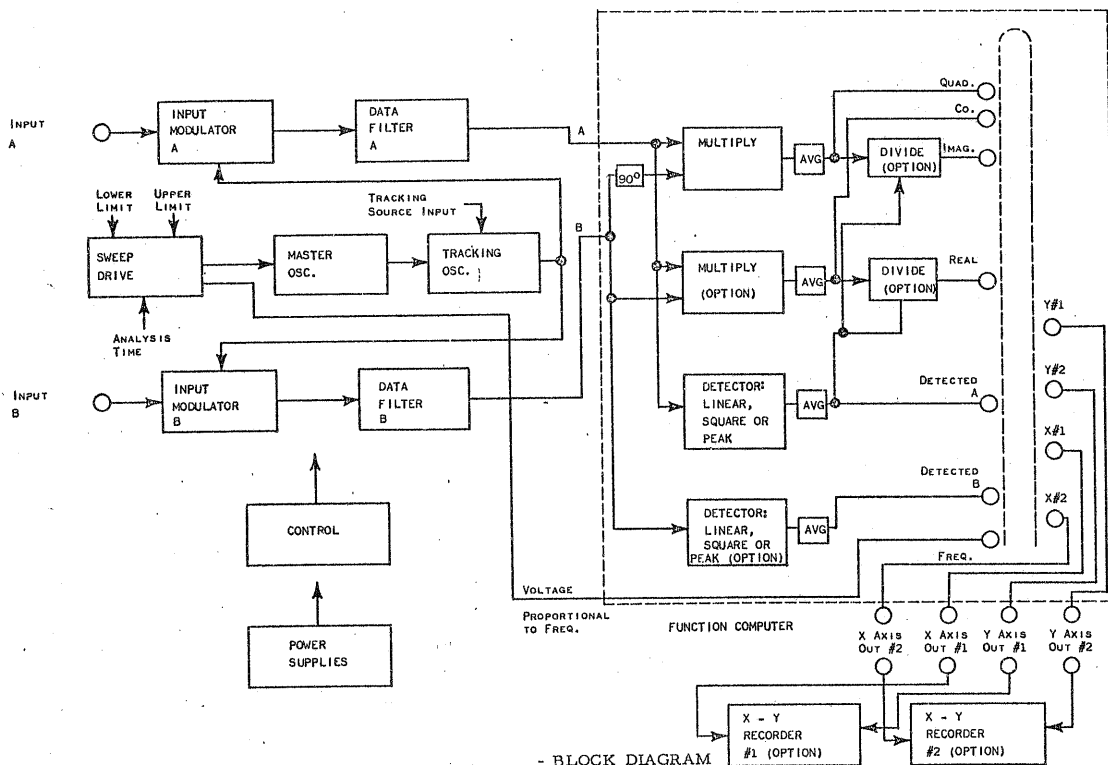

- BLOCK DIAGRAM  
TYPICAL COMPLEX TRANSFER FUNCTION ANALYZER  
USING 9300 A CONFIGURATION

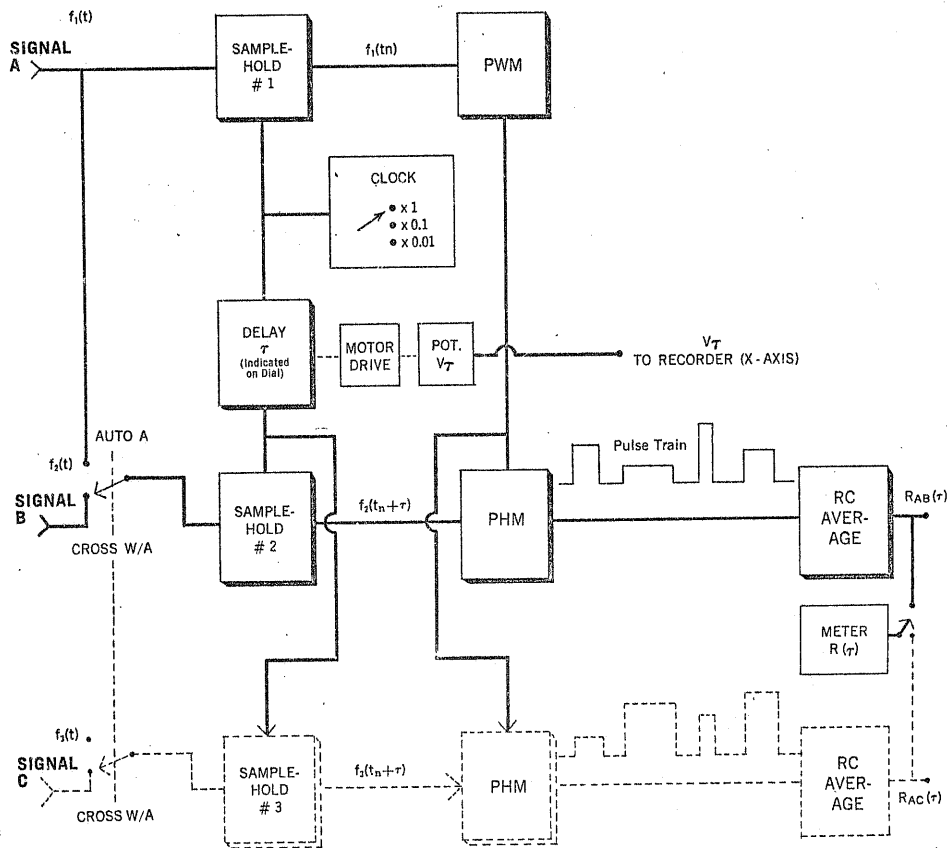

Model 9410 Time Delay Correlator - Simplified Diagram

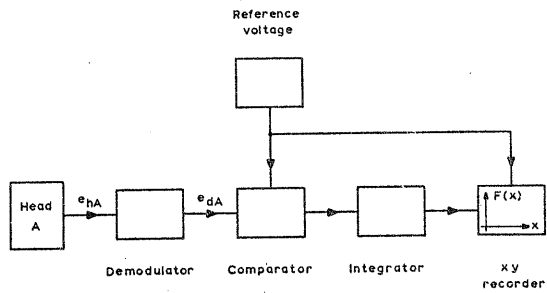
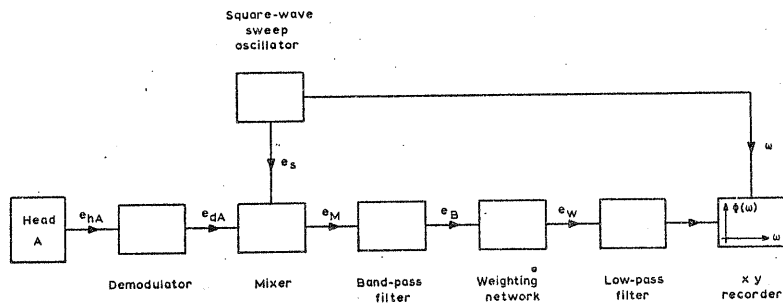
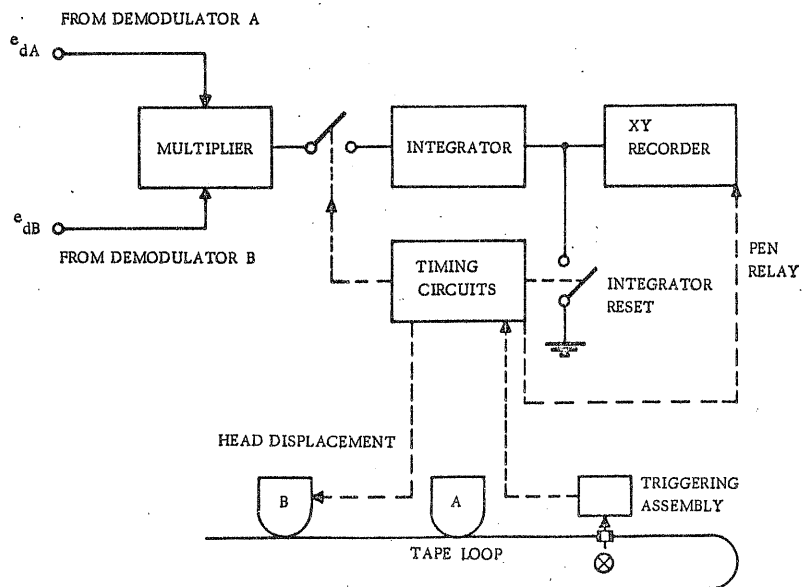

Fig. C-2. Simplified block diagram of distribution function section.



Simplified block diagram of power spectrum section.



Schematic block diagram of the correlator section.

FIG. 11.

NORATOM I.S.A.C.

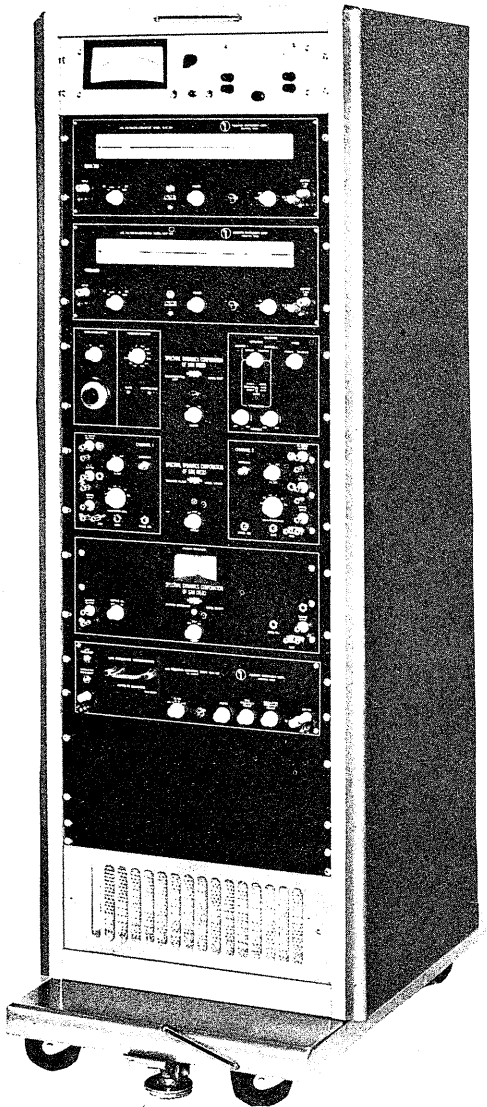

SD 1002A MOTION/ FORCE ANALYSER.

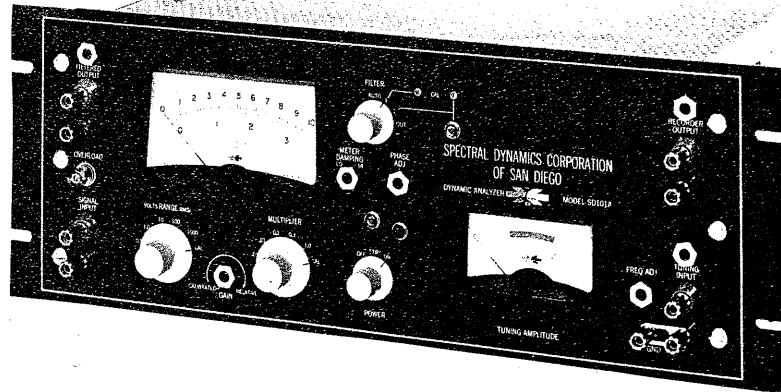

SD 101A DYNAMIC ANALYSER.

SD 102 DYNAMIC ANALYSER TUNER.



FIG 13 SPECTRAL DYNAMICS CORPORATION SYSTEM.

Figure 14A

SPECTRAL DYNAMICS CORPORATION

Mechanical Impedance Block Diagram

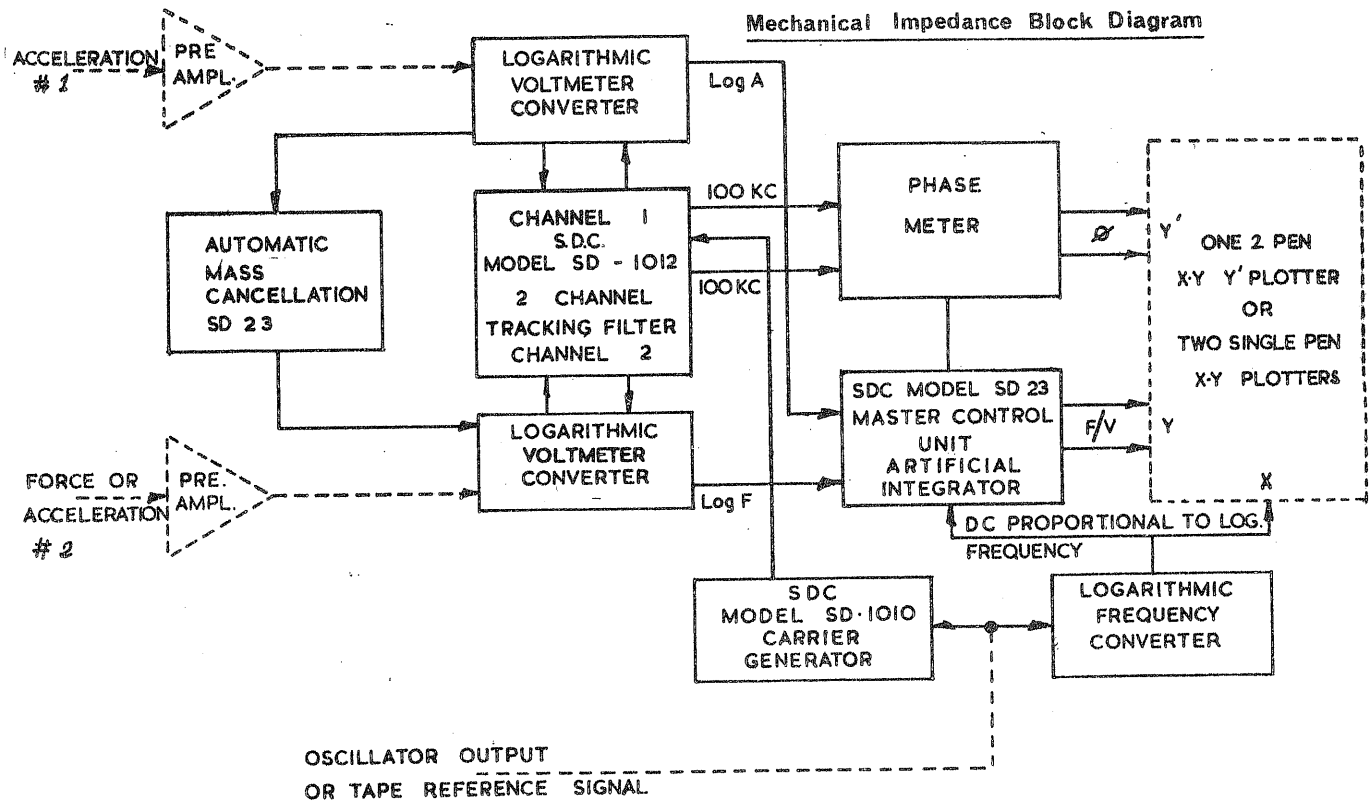
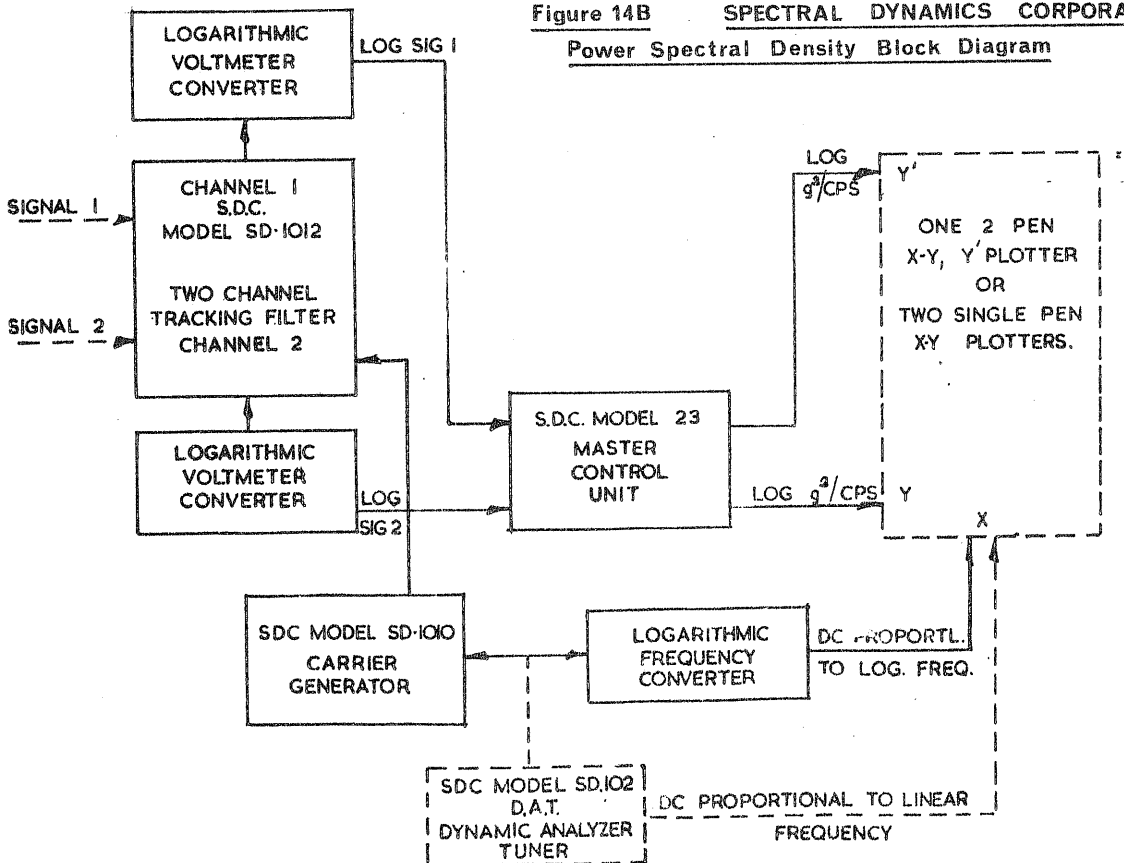
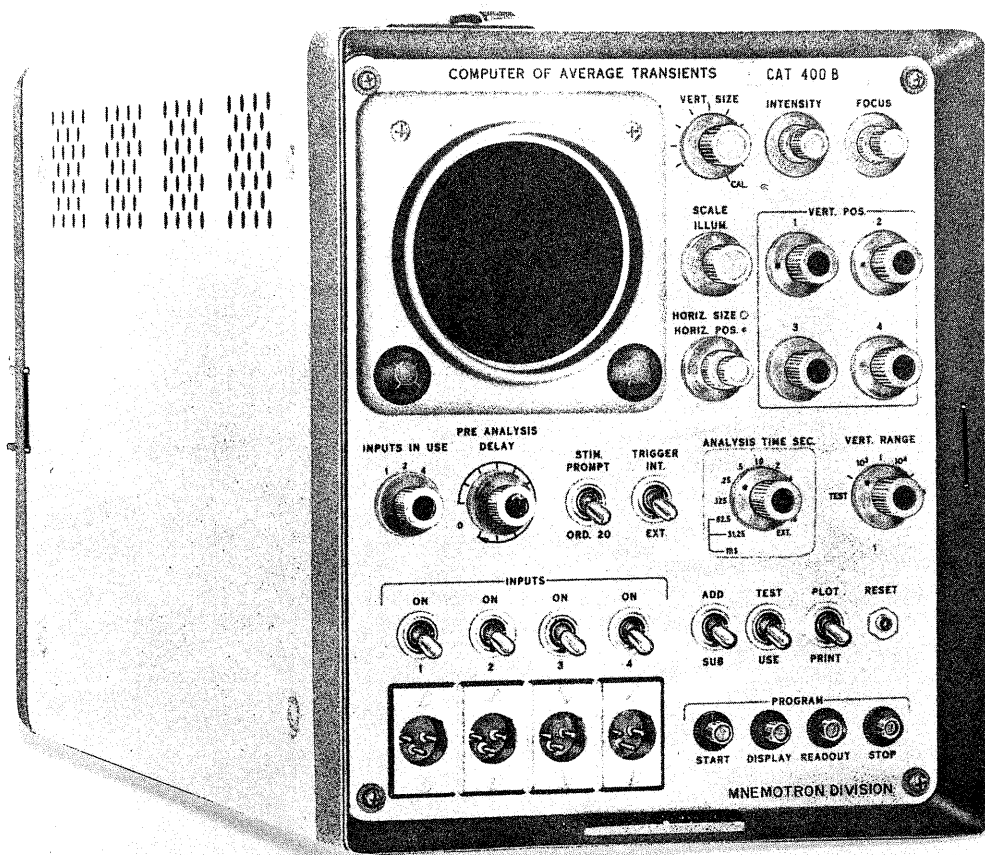

Figure 14B

SPECTRAL DYNAMICS CORPORATION

Power Spectral Density Block Diagram





TMC COMPUTER OF AVERAGE TRANSIENTS.

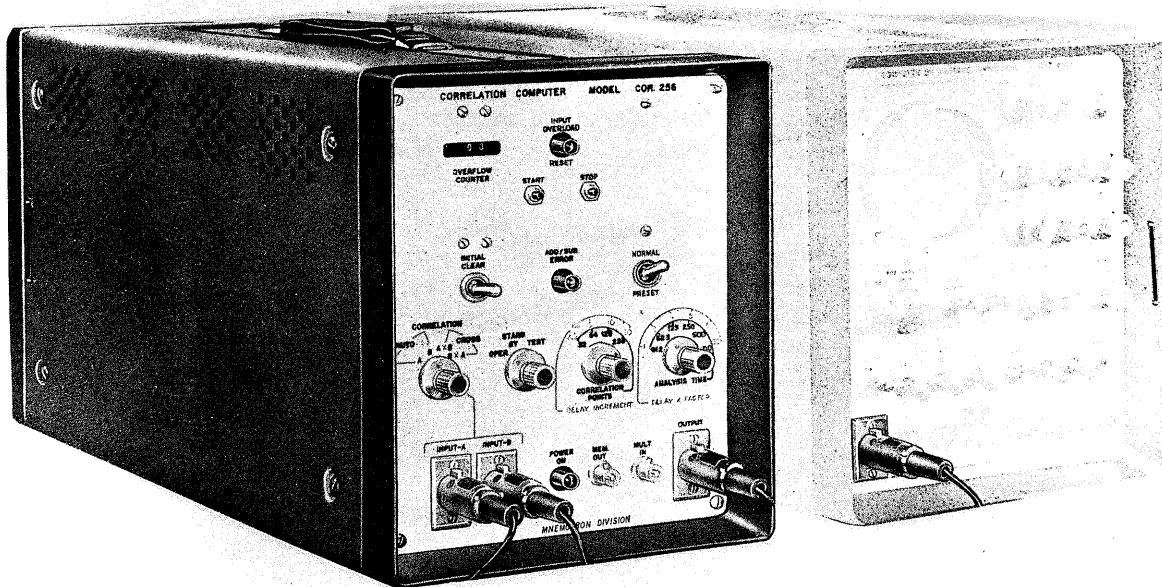
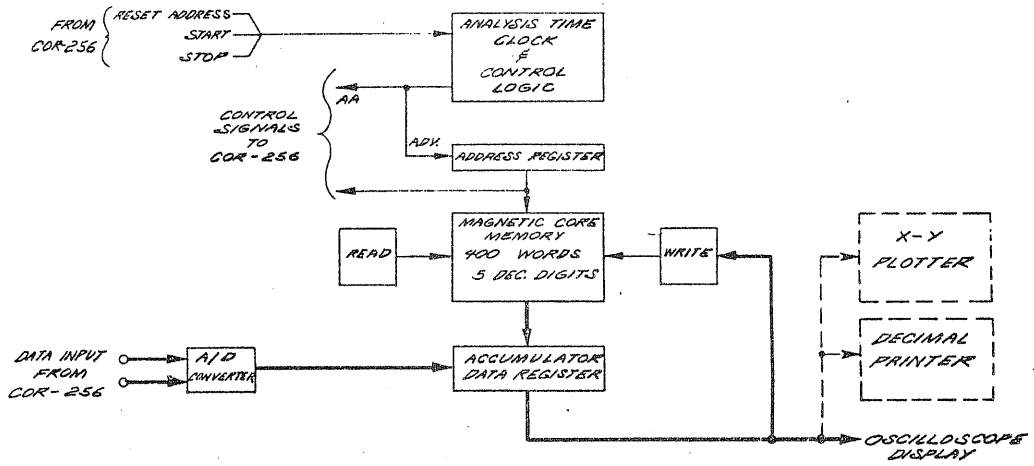
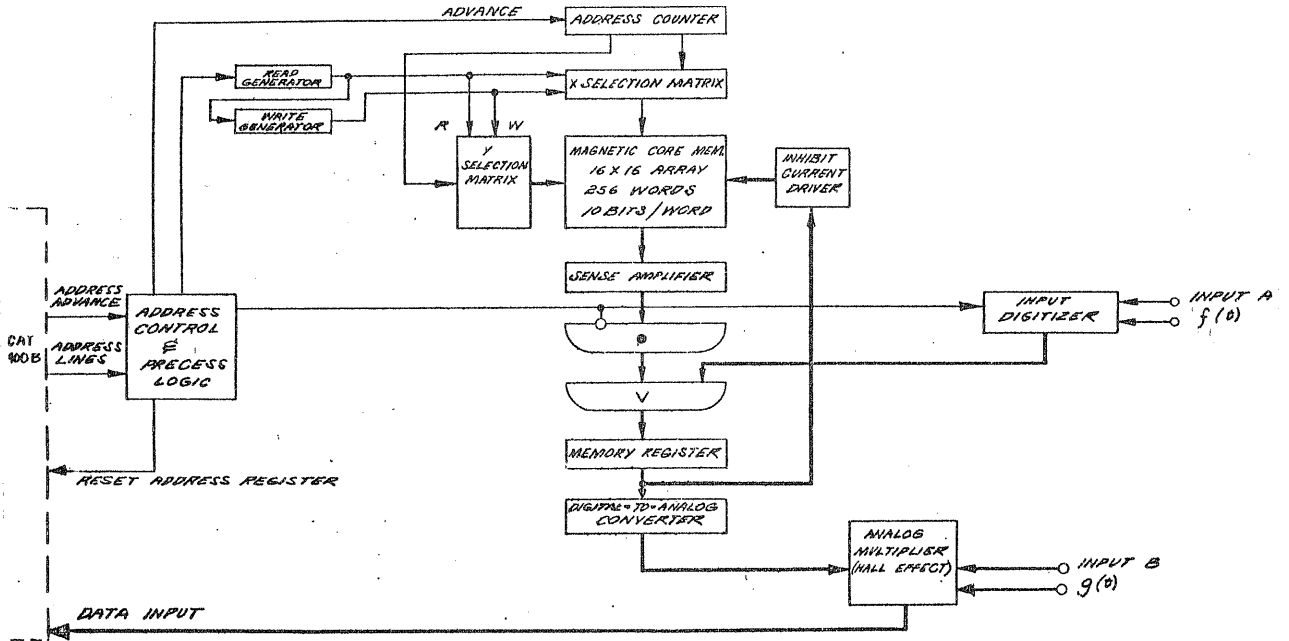

FIG 15 C.A.T. & CORRELATION COMPUTERS.



Block Diagram of CAT



Logic Diagram for Correlator

**FIG. 16. TECHNICAL MEASUREMENT CORPORATION C.A.T. & C.O.R. COMPUTERS.**

TP 626 T OSCILLATOR.

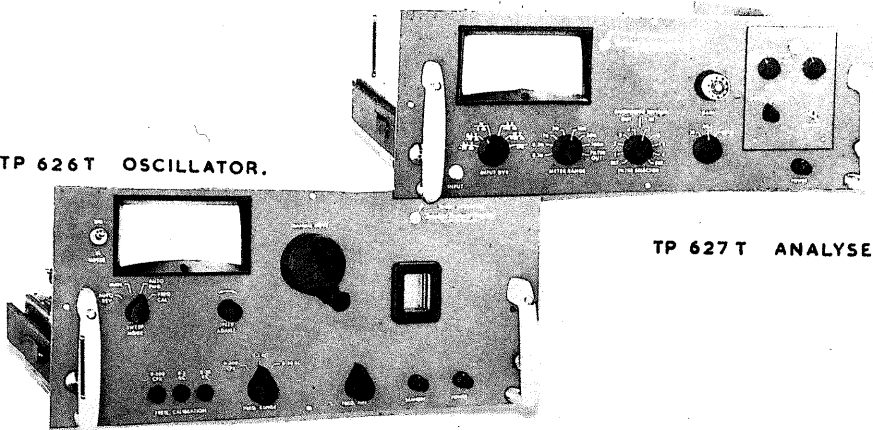

TP 627 T ANALYSER.

TP 644 OSCILATOR.



TP 645 MULTIPLIER.

FIG 17

TECHNICAL PRODUCTS  
COMPANY 625 WAVE  
ANALYSER SYSTEM.



TP 647 PROBABILITY  
ANALYSER.



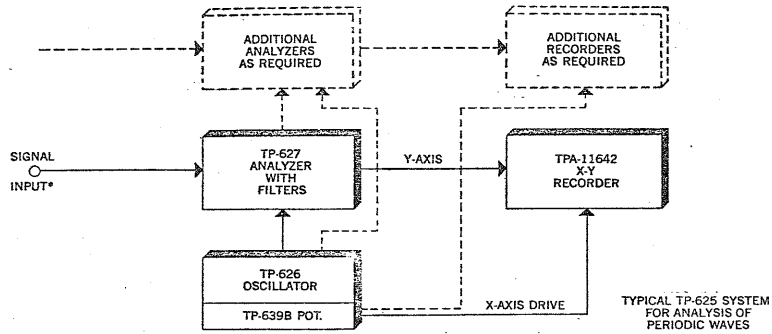

\*OFTEN A MAGNETIC LOOP REPRODUCER.

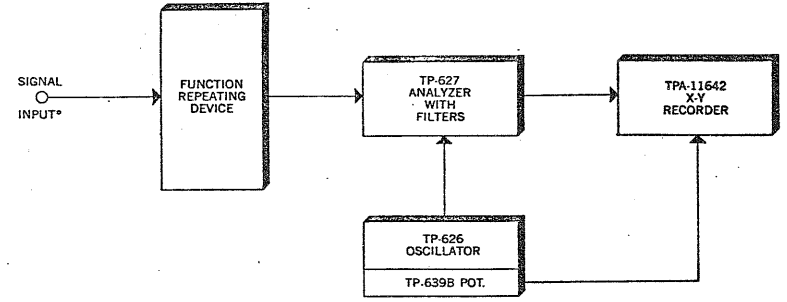

\*OFTEN A REEL-TO-REEL MAGNETIC TAPE REPRODUCER.

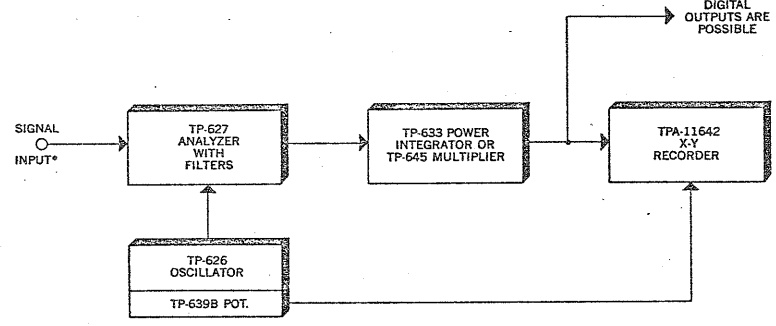

\*USUALLY A MAGNETIC TAPE REPRODUCER.

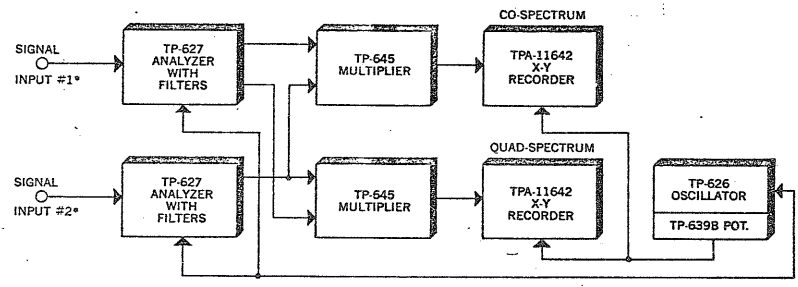

\*USUALLY A MAGNETIC TAPE REPRODUCER.

\*USUALLY A MAGNETIC TAPE REPRODUCER.

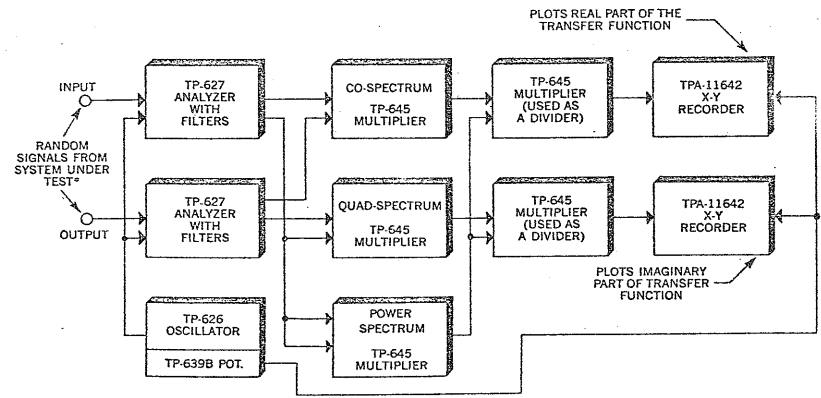

\*USUALLY ON MAGNETIC TAPE.

TP-625 TRANSFER FUNCTION ANALYZER

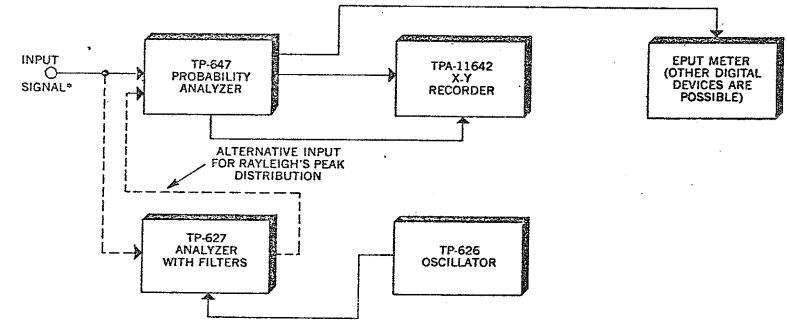

\*OFTEN A MAGNETIC TAPE LOOP

\*OFTEN A MAGNETIC TAPE LOOP

FIG. 18. TECHNICAL PRODUCTS COMPANY 625 WAVE ANALYSER SYSTEM.

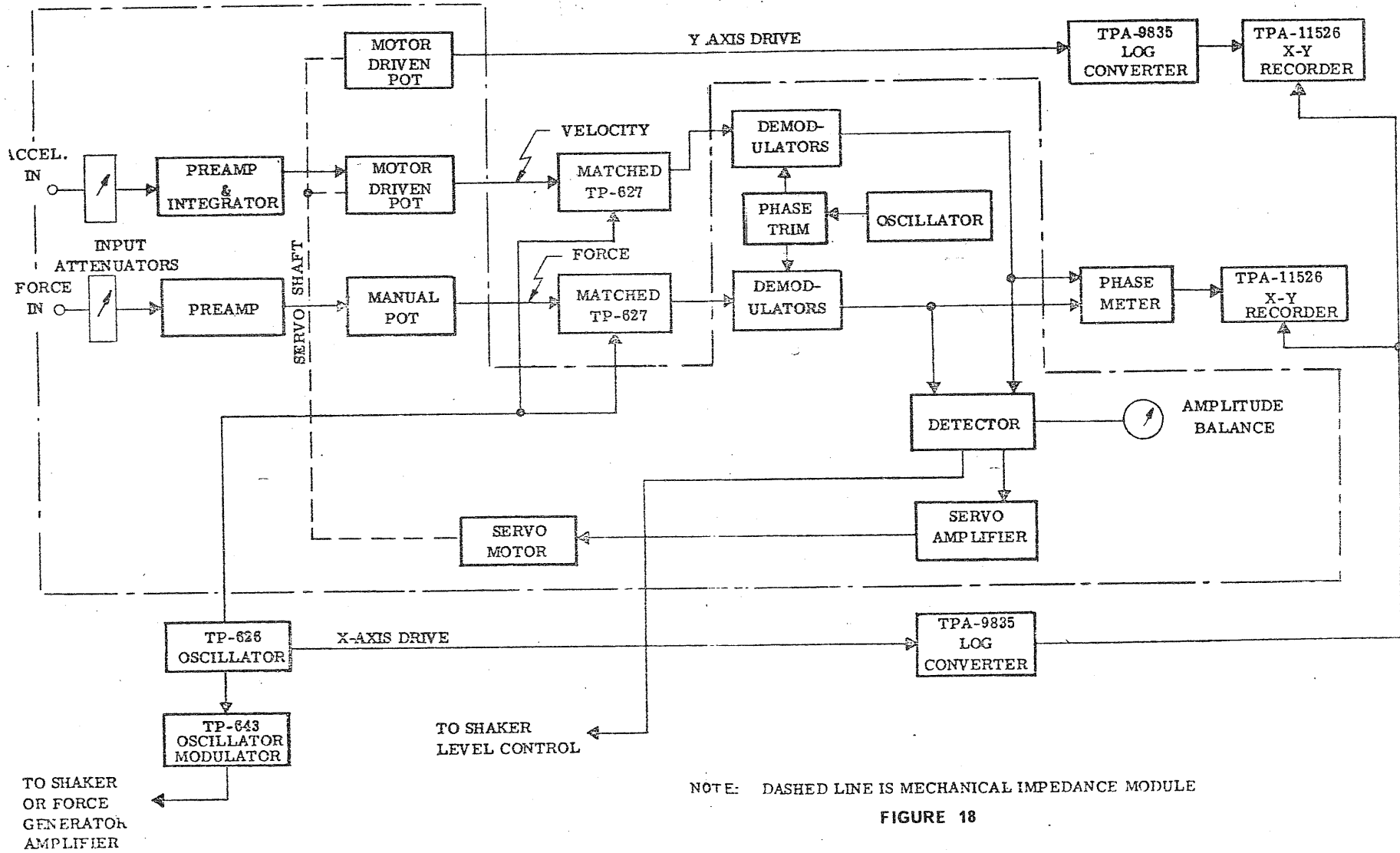
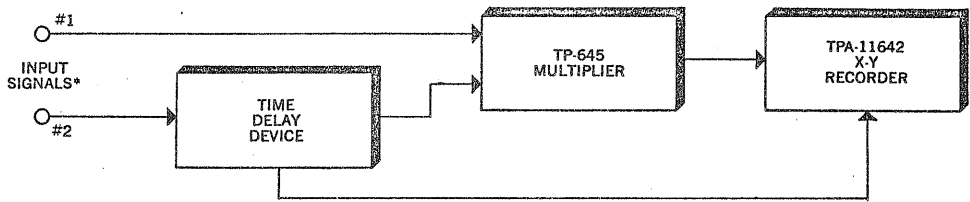
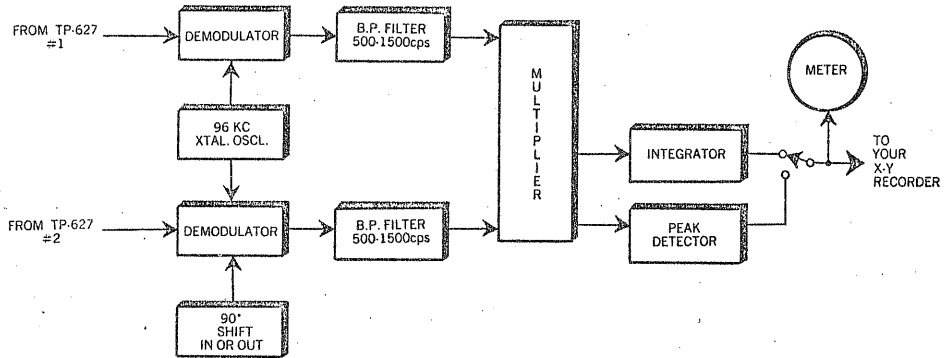

FIGURE 18



\*USUALLY ON MAGNETIC TAPE.

TYPICAL TP-625 SYSTEM FOR THE MEASUREMENT OF CORRELATION FUNCTIONS



TP-645  
FUNCTION  
DIAGRAM

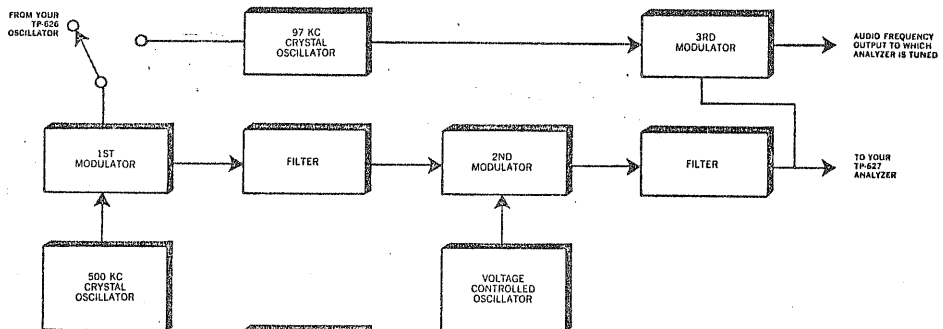

TP-644  
FUNCTION  
DIAGRAM

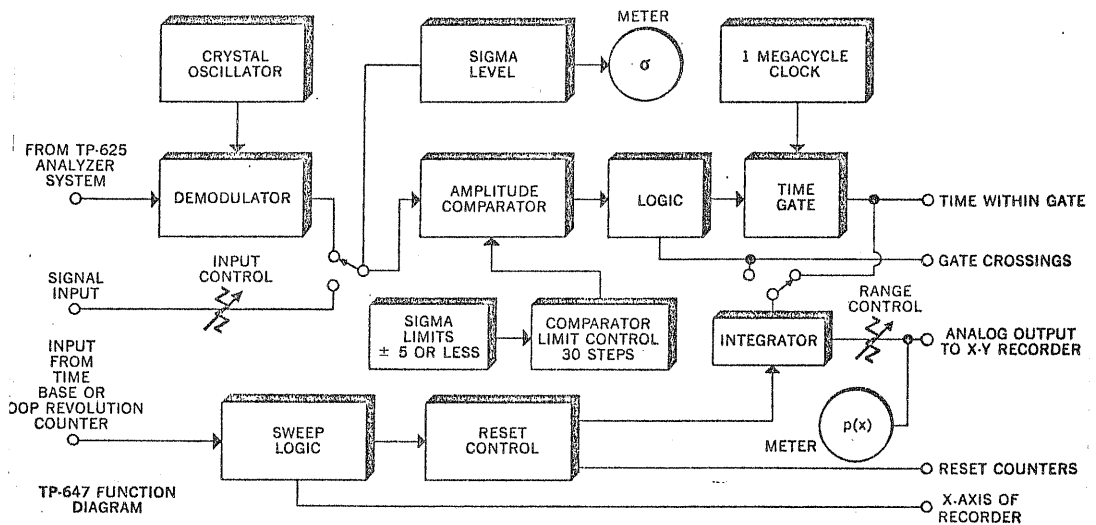

TP-647 FUNCTION  
DIAGRAM

FIG. 18. CONTINUED.