



## Local Storage Meets Local Demand: A Technical Solution to Future Power Distribution System

Zhou, B., & Littler, T. (2016). Local Storage Meets Local Demand: A Technical Solution to Future Power Distribution System. IET Generation, Transmission and Distribution, 10(3), 704-711. DOI: 10.1049/iet-gtd.2015.0442

### Published in:

IET Generation, Transmission and Distribution

### Document Version:

Peer reviewed version

### Queen's University Belfast - Research Portal:

[Link to publication record in Queen's University Belfast Research Portal](#)

### Publisher rights

Copyright 2016 IET.

This paper is a postprint of a paper submitted to and accepted for publication in IET Generation, Transmission & Distribution and is subject to Institution of Engineering and Technology Copyright. The copy of record is available at IET Digital Library.

### General rights

Copyright for the publications made accessible via the Queen's University Belfast Research Portal is retained by the author(s) and / or other copyright owners and it is a condition of accessing these publications that users recognise and abide by the legal requirements associated with these rights.

### Take down policy

The Research Portal is Queen's institutional repository that provides access to Queen's research output. Every effort has been made to ensure that content in the Research Portal does not infringe any person's rights, or applicable UK laws. If you discover content in the Research Portal that you believe breaches copyright or violates any law, please contact [openaccess@qub.ac.uk](mailto:openaccess@qub.ac.uk).

# Local Storage Meets Local Demand: A Technical Solution to Future Power Distribution System

Bowen Zhou<sup>\*</sup>, Tim Littler

School of Electronics, Electric Engineering and Computer Science, Queen's University Belfast, Queen's University Belfast, Belfast, BT9 5AH, UK

[\\*bruce233x@gmail.com](mailto:bruce233x@gmail.com)

**Abstract: Future power systems are expected to integrate large-scale stochastic and intermittent generation and load due to reduced use of fossil fuel resources, including renewable energy sources (RES) and electric vehicles (EV). Inclusion of such resources poses challenges for the dynamic stability of synchronous transmission and distribution networks, not least in terms of generation where system inertia may not be wholly governed by large-scale generation but displaced by small-scale and localised generation. Energy storage systems (ESS) can limit the impact of dispersed and distributed generation by offering supporting reserve while accommodating large-scale EV connection; the latter (load) also participating in storage provision. In this paper, a local energy storage system (LESS) is proposed. The structure, requirement and optimal sizing of the LESS are discussed. Three operating modes are detailed, including: 1) storage pack management; 2) normal operation; and 3) contingency operation. The proposed LESS scheme is evaluated using simulation studies based on data obtained from the Northern Ireland regional and residential network.**

## 1. Introduction

Global reduction of fossil fuel reliance alongside carbon dioxide emission reduction has promoted greater integration of renewable energy sources (RES) to meet demand targets and support changes in electric power systems. One major area of development directly affecting power systems is transportation electrification, which includes electric and hybrid road vehicles. It has been determined that in the UK, by 2020, there will be a total power demand of 35.3 GW with a planned installation of 17.9 GW of RES [1]. By the same year, it has also been estimated that in the UK there will be approximately 1.2 million battery electric vehicles (BEV) and 0.35 million plug-in hybrid electric vehicles (PHEV) [2]. It can be concluded that future UK power systems will require extensive integration of RES with conventional generation to support normal domestic, commercial and industrial loads in addition to capacity for stochastic loads, especially electric vehicles (EVs) and infrastructure, including energy storage.

Large-scale RES and large-scale EV can put pressure on transmission systems due to stochastic and intermittent connection characteristics. RES generation power is obtained from natural resources, which is of low controllability. On the contrary, EV charging and discharging power can be managed to meet certain objectives such as load levelling, RES support, and emergency power supply. This is of significant value for UK local distribution systems. More than 75% of the claimed RES by 2020 will be from centralized or large power plants [1] while distributed generation (DG) (from embedded wind and solar

plant) will be less. For a small distribution network, the distributed RES capability cannot usually meet local demand, especially if there is no external power supplier. Moreover, by taking into consideration EV provision, the capacity situation is further aggravated.

Energy storage systems (ESS) facilitate control of power system stability [3], [4], power and energy balancing [4]-[6] and RES provision [6], [7]. Due to the cost, lifetime, efficiency and variation in ESSs, they are mainly installed at transmission level. However, if it is assumed that in the future these constraints will be advanced or minimised, technical solutions for distribution level will emerge, thus providing local storage to meet local demand. In other words, with RES and ESS provision, local solutions for local problems will be feasible. This is of particular importance to EVs.

For a simple two terminal system, an ESS is conventionally installed at the sending end (feeder) to stabilise output. This is the most likely choice for system operators at present because the system load, showing a periodic feature, can be predicted accurately and maturely, and the only task is to control the generation alongside load. However, future power systems will typically be defined by integration of large-scale EV numbers and, to date, a viable solution to accurately predict EV charging demand has not yet been proposed.

If ESS installation is considered at the receiving (load) end, both the stochastic feeder output and demand can be omitted. Moreover, an ESS can also supply battery charging for EVs and emergency power for local demand during contingency and preserve transmission and protection constraints.

In this paper, and with respect to EV charging and energy consuming processes, a local energy storage system (LESS) is proposed. Section II firstly introduces the typical structure of LESS, and then proposes the requirements and optimal sizing of the LESS. The optimal daily benefits of the LESS are also discussed. Section III discusses three operating modes of the LESS scheme which are storage pack management of the LESS, normal operation and contingency operation. The proposed LESS solution is evaluated in the Northern Ireland power distribution network in Section IV, where a loss-of-load evaluation is also proposed.

## **2. A LESS solution**

The principle of a LESS solution is that local storage meets local demand. The basic concept is that the original structure of the distribution grid remains the same while an ESS is added as the energy supplier for EV charging as well as the emergency power supplier during contingencies. Detailed information of the LESS solution is discussed as follow.

### *2.1 LESS Structure*

There are three major parts in a LESS as shown briefly in Fig. 1. A LESS consists of ESS and local RES and is divided into two levels.

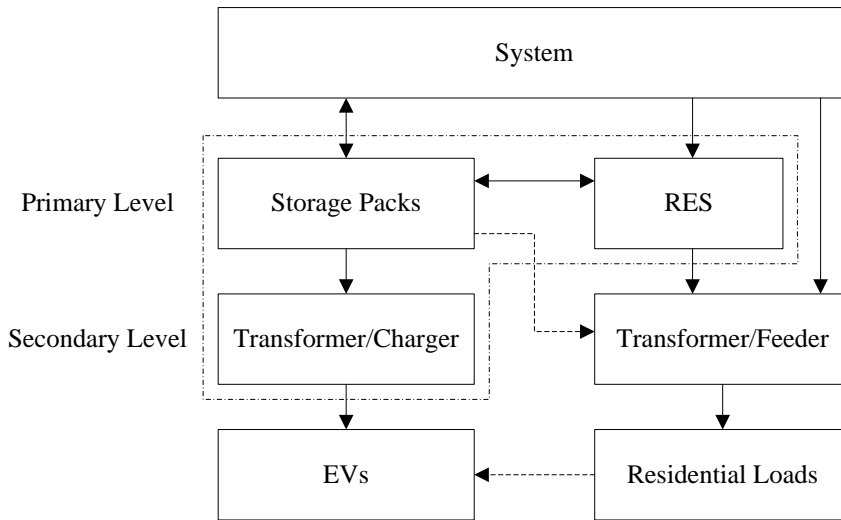

Fig. 1. Structure of the LESS solution

The primary level is connected directly with the system and it refers to the unit storage packs and RES. There will be more than 2 packs in a single ESS. When one pack is being replenished (with charge) by the system, the other packs can provide a non-interruptible charging service to local EVs.

The secondary level consists of the necessary support infrastructure, including transformers and chargers to maintain the voltage level suitable for EV charging. In this paper, the EV discharging process is neglected.

When the local distribution grid is disconnected from the power system during certain contingencies, local storage and RES can still provide power and energy supply to local residential loads. Moreover, EVs can also be charged at home through residential sockets.

## 2.2 Requirements for LESS

The requirements for LESS come from ESS itself, EVs RES and local residential loads.

2.2.1 Requirements from ESS: Currently there are six major types of ESSs widely used in power systems, which are listed in Table 1 [4], [5].

Table 1 Type of ESSs

Type	Example
Gravitational	Pump hydro storage (PHS)

Spatial	Compressed air energy storage (CAES)
Kinetic	Flywheel energy storage (FES)
Electric	Capacity energy storage (CES)
Electromagnetic	Superconducting magnetic energy storage (SMES)
Electrochemical	Battery energy storage systems (BESS)

PHS, CAES and FES use mechanical subassemblies. During energy charging and discharging, this kind of ESS is more severely limited by the upper and lower ramping limits [7]. In comparison with BESS, CES and SMES both have lower energy density [4]. The advantages of BESS for applications are: high energy density, high energy capability, round trip efficiency, cycling capability, life span, and initial cost [4], [8]. Thus, BESS is a good option for the LESS scheme.

If  $P_c$  and  $P_d$  are the rated charging and discharging power of the storage packs, then the power capacity of the storage packs can be expressed as

$$P_{ESS} = \max\{P_c, P_d\} \quad (1)$$

In this paper, power losses in the storage packs are neglected. It is also assumed that the charging duration is usually longer than the discharging duration,

$$P_d = \eta P_c \quad (2)$$

where,  $\eta$  is a coefficient and  $\eta > 1$ .

The rated energy capacity of the ESS  $E_{ESS}$  is

$$E_{ESS} = \sigma_{ESS} N_{ESS} P_{ESS} T_{ESS} \quad (3)$$

where  $\sigma_{ESS}$  is the energy capacity margin coefficient,  $N_{ESS}$  is the numbers of the storage pack and  $T_{ESS}$  is the charging duration. Usually  $E_{ESS}$  will be several times larger than  $N_{ESS} P_{ESS} T_{ESS}$  since the batteries cannot be fully discharged and there is a minimal level of the depth-of-discharge (DoD).

*2.2.2 Requirements form EVs:* EV charging demand is stochastic and intermittent. However, with practical EV charging capacity forecasting, EV charging demand during each time interval can be obtained [6], [9]. The capacity of each unit storage pack should be larger than the maximum EV charging demand, which is shown in (4).

$$P_d \geq \max\{P_{EV}(l)\} \quad (4)$$

where  $P_{EV}(l)$  is the EV charging power at time  $l$ .

*2.2.3 Requirements from RES:* The net load of power systems increases significantly during the peak load period when RES penetration decreases, which will cause a power shortage in power systems. Moreover, abundant RES generation in valley load period can lead to a serious conflict with traditional generation [2], [7]. A BESS has a rapid response speed and can relieve such problems. By taking into account disconnected operation with the bulk power systems, the capacity of each unit storage pack should be larger than the maximum RES generation power, which is shown in (5).

$$P_c \geq \max \{P_{RES}(l) - P_L(l)\} \quad (5)$$

where,  $P_{RES}(l)$  is the RES generation power at time  $l$  and  $P_L(l)$  is the load power at time  $l$ .

*2.2.4 Requirements from Local Residential Loads:* In the most severe condition, the local distribution grid is disconnected to the power system due to a contingency. However, the LESS should be able to supply power to the whole residential loads as well as EVs. Thus, the sum of the capacity of the LESS and the RES power should be larger than the sum of the maximum EV charging demand and the peak of residential loads during LESS discharging, which is shown in (6). And the capacity of the LESS should be larger than the net generation power when RES power is abundant and LESS is under a charging mode, which is shown in (7). However, due to financial constraints, the energy capacity of the LESS will not be designed to cover 24-hour disconnected operation, which is limited by  $T_{ESS}$ .

$$P_d + \max \{P_{RES}(l)\} \geq \max \{P_{EV}(l) + P_L(l)\} \quad (6)$$

$$P_c \geq \max \{P_{RES}(l) - P_{EV}(l) - P_L(l)\} \quad (7)$$

Taken into account (2) and the power flow constraints  $P_{PF}$ , (4) - (7) can be rewritten as

$$\max \left\{ \begin{array}{l} \max \{P_{RES}(l) - P_{EV}(l) - P_L(l)\}, \\ \frac{1}{\eta} \max \{P_{EV}(l)\}, \\ \frac{1}{\eta} (\max \{P_{EV}(l) + P_L(l)\} - \max \{P_{RES}(l)\}) \end{array} \right\} \leq P_c \leq \min P_{PF} \quad (8)$$

### 2.3 Optimal Sizing of LESS

The rated power and capacity are the most important parameters for an ESS facility planning as they directly influence system operation and consequently profit. In this paper, an economic cost-benefit model is proposed to obtain the optimal sizing of a potential LESS scheme.

*2.3.1 Object Function:* The total cost includes the financial investment of ESS  $S_{c\_ESS}$ , RES  $S_{c\_RES}$ , transformers and chargers  $S_{c\_T}$  and other necessary equipment  $S_{c\_O}$  and the operation and maintenance cost

$S_{c\_M}$ . The benefits include the operation income of the ESS  $S_{b\_ESS}$  and power supply income of the RES  $S_{b\_RES}$ . Thus, the daily benefit of the LESS scheme,  $S$  can be obtained as follows,

$$\begin{aligned} S &= S_b - S_c \\ &= S_{b\_ESS} + S_{b\_RES} - (S_{c\_ESS} + S_{c\_RES} + S_{c\_T} + S_{c\_O} + S_{c\_M}) \end{aligned} \quad (9)$$

where,

$$\begin{aligned} S_{b\_ESS} &= h_d \sum_l P_d(l) \frac{24}{N} - h_c \sum_l P_c(l) \frac{24}{N} \\ S_{b\_RES} &= h_{RES\_o} \sum_l P_{RES}(l) \frac{24}{N} \\ S_{c\_ESS} &= h_{ESS\_p} P_{ESS} + h_{ESS\_e} E_{ESS} \\ S_{c\_RES} &= h_{RES\_i} P_{RES\_i} \\ S_{c\_T} &= h_T P_{ESS} \\ S_{c\_O} &= h_O P_{ESS} \\ S_{c\_M} &= h_M P_{ESS} \end{aligned} \quad (10)$$

and where  $N$  is the number of discrete time intervals;  $h_d$  and  $h_c$  are the electricity selling price during discharging and electricity purchasing price during charging of the ESS;  $h_{RES\_o}$  is the electricity selling price of the RES;  $h_{ESS\_p}$  is the daily investment cost per unit power of the ESS;  $h_{ESS\_e}$  is the daily investment cost per unit energy capacity of the ESS;  $h_{RES\_i}$  is the daily investment cost per unit power of the RES and  $P_{RES\_i}$  is the total installed capacity of the RES;  $h_T$  is the daily investment cost of the transformers and chargers in the LESS;  $h_o$  is the daily investment cost of other necessary equipment in the LESS; and  $h_M$  is the daily operation and maintenance cost of the LESS.

**2.3.2 Discussion of Daily Benefits:** In (10),  $S_{c\_RES}$  can be regarded as a constant if  $P_{RES\_i}$  is fixed.  $S_{b\_RES}$  is determined by the RES prediction or by records. Its value varies significantly, according to different prediction methods. However, taking into account a static RES generation profile,  $S_{b\_RES}$  is determined by the electricity selling prices in different time periods.  $S_{b\_RES}$  is also fixed if the electricity tariff is fixed. The other parameters can be simplified as a linear term of  $P_c$  or  $P_d$  if  $T_{ESS}$  is a constant. Thus, the object function can be rewritten as,

$$S = DP_c + C \quad (11)$$

where

$$\begin{aligned} DP_c &= S_{b\_ESS} - (S_{c\_ESS} + S_{c\_T} + S_{c\_O} + S_{c\_M}) \\ C &= S_{b\_RES} - S_{c\_RES} \end{aligned} \quad (12)$$

and where  $C$  and  $D$  are the coefficients.

In (10), when  $S > 0$ , the LESS scheme is considered economically beneficial, and when  $S < 0$ , it is considered that the LESS scheme is not worthy to be constructed. From (10)-(12) it can be concluded that the daily benefit of the LESS scheme is mainly affected by the electricity tariff, EV charging profile and the capacity of the ESS element used in the LESS scheme.

When the electricity tariff is high and the purchasing price low, the daily benefit is effectively higher and thus *beneficial*; when the LESS capacity is small the total cost is also smaller, which is also beneficial; the EV charging profile is obtained by capacity forecasting and the requirements for the LESS have to be considered.

### 3. LESS operation

The proposed LESS will operate within three modes: 1) storage pack management; 2) normal operation with the system connected; and 3) contingency operation with the system disconnected.

#### 3.1 Storage Pack Management

Fig. 2 shows the flow chart of the storage pack management.

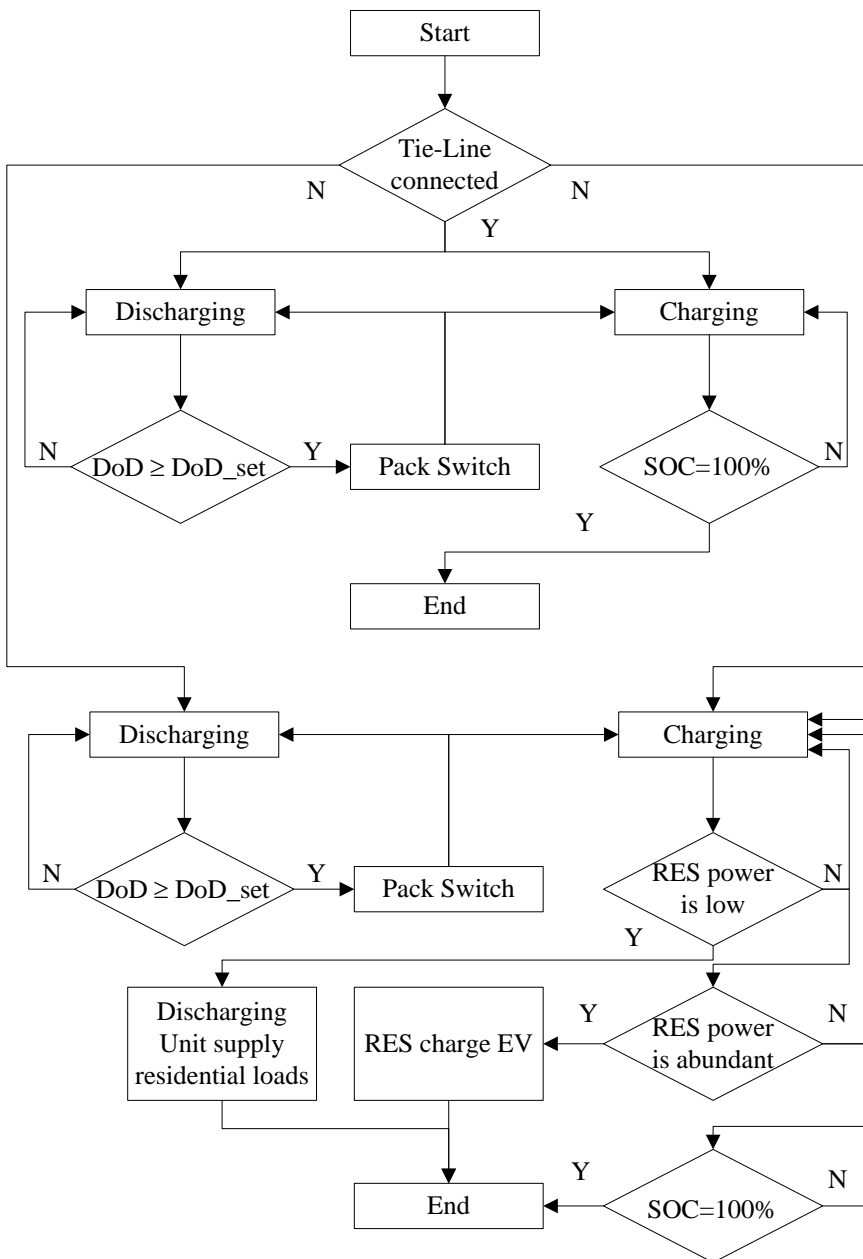



Fig. 2. Flow chart of the storage pack management

The storage pack management has two parts: normal operation and contingency operation. When the LESS is under normal operation mode, if DoD is smaller than the setting value, the discharging unit and the charging unit will be switched. When the LESS is under contingency mode, the RES power should be examined. When the RES power is low, the discharging unit should supply power to the residential loads, which can be seen in (6). When the RES power is abundant, RES should be able to charge EVs, which can also be seen in (7). After the charging unit is fully charged, it is ready to be switched to discharge.

### 3.2 Normal Operation Mode

When the LESS is connected to a bulk power system through a tie-line, the power direction will either be from the LESS or to the LESS. Thus, the optimal object of the EV demand profile is tie-line regulation. By considering the general model for EV capacity forecasting in [10], the transferred power through the tie-line can be expressed as,

$$\begin{aligned}
 P_s(t) &= P_c(t) + P_t(t) + P_{EV}(t) - P_d(t) \\
 \min z &= \frac{1}{N_d} \sum_{t=1}^{N_d} (P_s(t) - \bar{P}_s)^2 \\
 \min z &= \sum_{t=1}^{N_d} P_s(t)^2 \\
 \text{s.t.} &\begin{cases} \sum f(t) + \sum g(t) = 1 \\ f(t) \geq 0, g(t) \geq 0, \forall t \in [1, N_d] \end{cases}
 \end{aligned} \tag{13}$$

where  $P_t(t)$  is the tie-line transferred power without EVs or LESS at time  $t$ .  $\bar{P}_s$  is the mean level.  $z$  is the objective function and  $f(t)$  and  $g(t)$  are the decision variables.

By considering (8), (9) and (13), the optimal size of the LESS, the daily benefit and EV charging profile can be obtained.

### 3.3 Contingency Operation Mode

When the LESS is islanded, the prime task of the LESS is to maintain power supply and the second task is to reduce RES power curtailment. Thus, the objective function is

$$\begin{aligned}
 P_s(t) &= P_c(t) + P_L(t) - P_{RES}(t) + P_{EV}(t) - P_d(t) \\
 \min z &= \frac{1}{N_d} \sum_{t=1}^{N_d} (P_s(t) - \bar{P}_s)^2 \\
 \min z &= \sum_{t=1}^{N_d} P_s(t)^2 \\
 \text{s.t.} &\begin{cases} \sum f(t) + \sum g(t) = 1 \\ f(t) \geq 0, g(t) \geq 0, \forall t \in [1, N_d] \end{cases}
 \end{aligned} \tag{14}$$

where,  $P_L(l)$  is the gross demand without EVs at time  $l$ .

## 4. Case study

### 4.1 Parameters

Lisburn is the third largest city in Northern Ireland (N.I.) which is 9 miles away from Belfast city centre. Many residents in Lisburn travel to Belfast during the Monday-Friday workdays making this city a useful example to study large-scale EV usage and integration.

Based on the population and total EV numbers in the U.K., it is supposed that there will be 2280 BEVs and 660 PHEVs in Lisburn in 2020 [2]. Thus the charging power level is set to 7 kW for standard charging [11]. The wind energy capacity is set to 20 MVA [1]. The power network structure of Lisburn area is shown in Fig. 3.

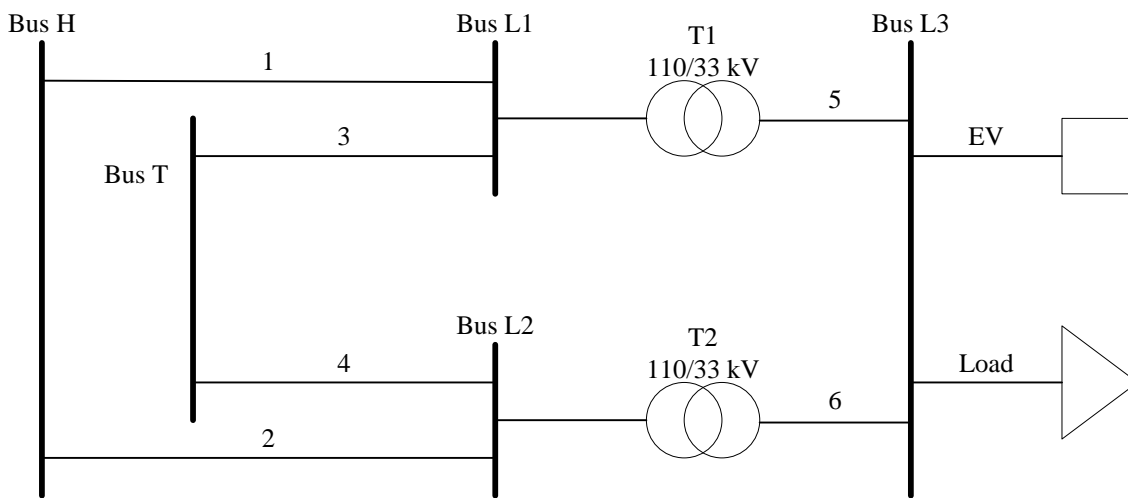

Fig. 3. The power network structure of Lisburn area

Based on historical data [12] and by taking into account improvements in energy efficiency and ‘Gone-Green’ scenarios [13], the projected daily winter load demand profile and the wind generation power profile in Lisburn in 2020 are shown in Fig. 4

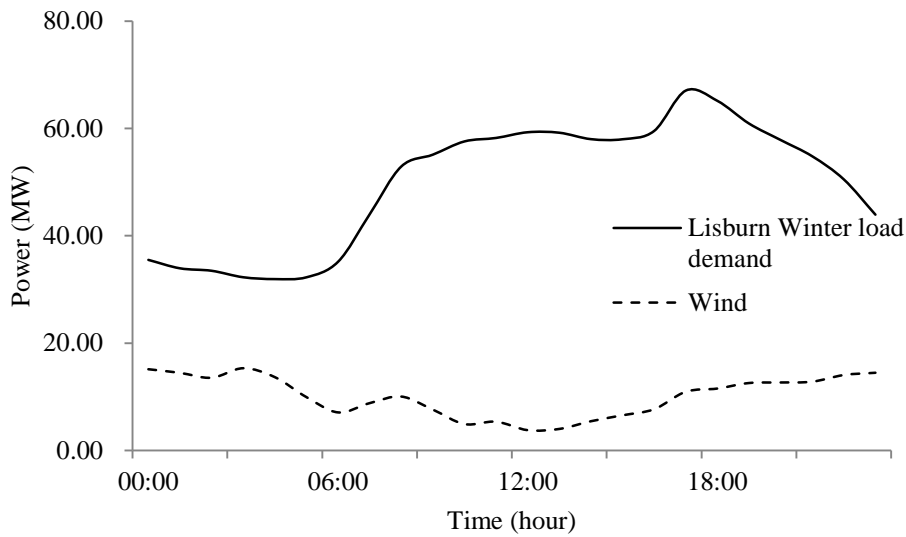

Fig.4. Lisburn winter load demand

Parameters for LESS sizing are listed in Table 2 and Table 3 [7], [14].

Table 2 Parameters of LESS

Symbol	Value	Symbol	Value
$\eta$	2	$\sigma_{ESS}$	1.5
$N_{ESS}$	2	$N$	24
$T_{ESS}$	8	$h_{ESS\_p}$	25p/kW-d
$h_{ESS\_e}$	82p/MWh-d	$h_{RES\_i}$	11p/kVA-d
$h_T$	7 p/kW-d	$h_O$	5 p/kW-d
$h_M$	8 p/kW-d		

Table 3 Electricity tariff in different time periods

	Time period	Price (p/kWh)
$h_1$	22:00-06:00	11
$h_2$	06:00-08:00	13
$h_3$	08:00-10:00, 18:00-21:00	17
$h_4$	10:00-18:00, 21:00-22:00	14
$h_{RES\_o}$	All day	15

#### 4.2 Normal Operation Mode

The calculation results are shown in Fig. 5. The optimal sizing results are  $P_{ESS} = 24\text{MW}$  and  $E_{ESS} = 576\text{MWh}$ . The daily benefit of the LESS  $s$  is £-4,185.

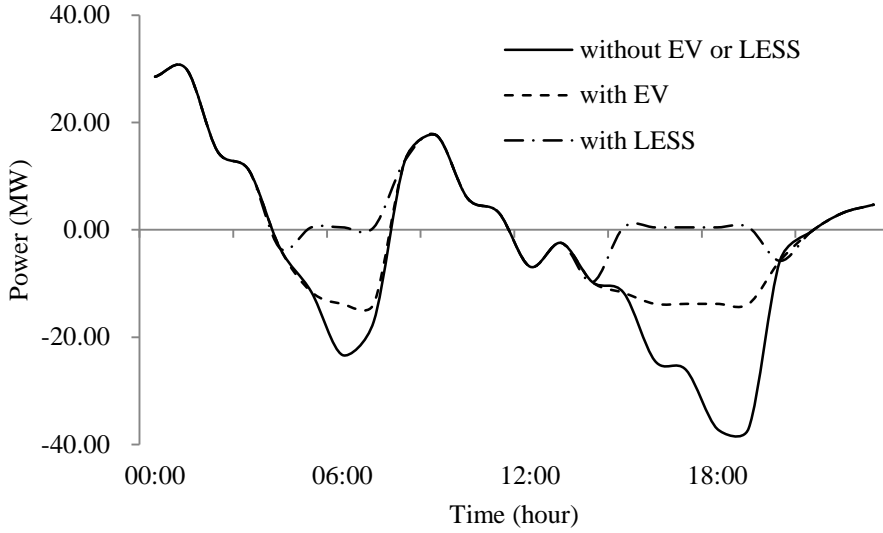

Fig. 5. Simulation results under normal operation mode

In this mode, LESS discharging is considered to supply EV battery charging or local residential loads only. Thus, only the negative part in Fig. 5 is optimised. From Fig. 5 it can be obtained that with EV optimal charging, the deviation of the transferred power in the tie-line is reduced from 67MW to 44MW. Inclusion of the LESS scheme improves local supply with a further reduction of 4MW; however there are still fluctuations due to charging duration limit of the ESS.

The daily benefit is negative, meaning that under this condition or market circumstance, the LESS scheme is not economically beneficial. There are two reasons. The first is that the incomes of RES generation and ESS discharging are not too much and the ESS charging periods are mostly in the high electricity price periods. In this study, electricity selling price is set as a constant. If it is also considered as different in different time periods, the incomes might increase. The second reason is that the size of the ESS is rather big.

#### 4.3 Contingency Operation Mode

The optimal sizing results are  $P_{ESS} = 57\text{MW}$  and  $E_{ESS} = 1368\text{MWh}$ . The daily benefit  $s$  is £-31,324. This is an unacceptable size for the ESS. The size is very large because of (6), using LESS to meet the requirement from local residential loads.

Ignoring (6), the optimal results are  $P_{ESS} = 25\text{MW}$  and  $E_{ESS} = 600\text{MWh}$ . This is comparatively close to the results for normal operation mode. The daily benefit  $s$  in this condition is £5,465. The calculation results are shown in Fig. 6.

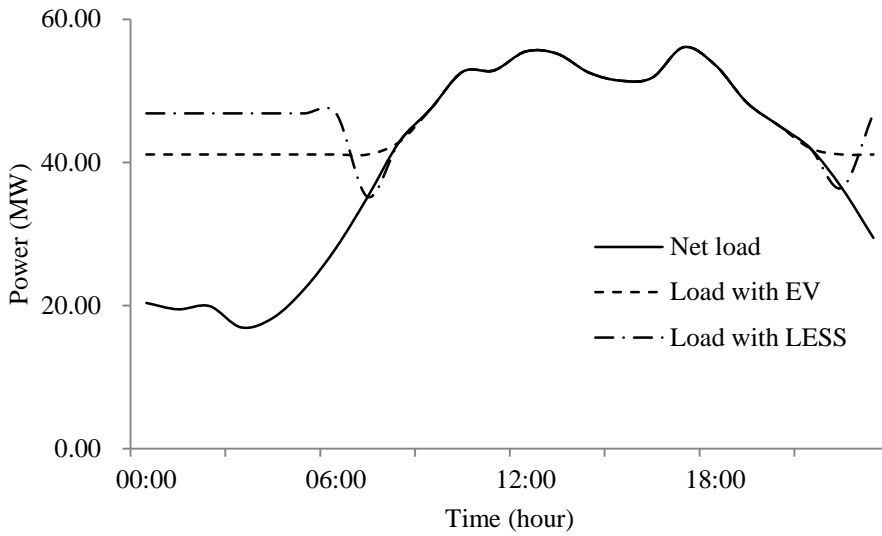

**Fig. 6.** Simulation results under contingency operation mode

From Fig. 6 it can be seen that the RES can be supported by EV. There are two apparent fluctuations in this figure due to limited charging duration of the ESS. The size of the ESS is larger than that in Part 4.2 but the daily benefit is positive. This is because the charging units are charging during a low electricity price period from 23:00-07:00, which reduces cost.

By comparing the above two operating modes, it can be concluded that the LESS is not quite useful during normal operation (connected to the system) since it is not beneficial. As long as the LESS is operating, there will be a daily cost of £4,185. The LESS will be reasonably beneficial with a daily economic benefit of £5,465 during islanding with some loss-of-load which is discussed as follows.

#### 4.4 Loss-of-load Evaluation

In normal operation and without the LESS scheme, the tie-line power fluctuation can be reduced by EV charging and the demand can be met by the bulk power system. However, with respect to the RES deployment in N.I. in 2020, the RES is fixed [1] while the ESS capacity can be minimised. Moreover, the ESS size can be modified separately in this case if the electricity tariff is affected by broader circumstances. Fig. 7 provides the curve of daily benefit to ESS size.

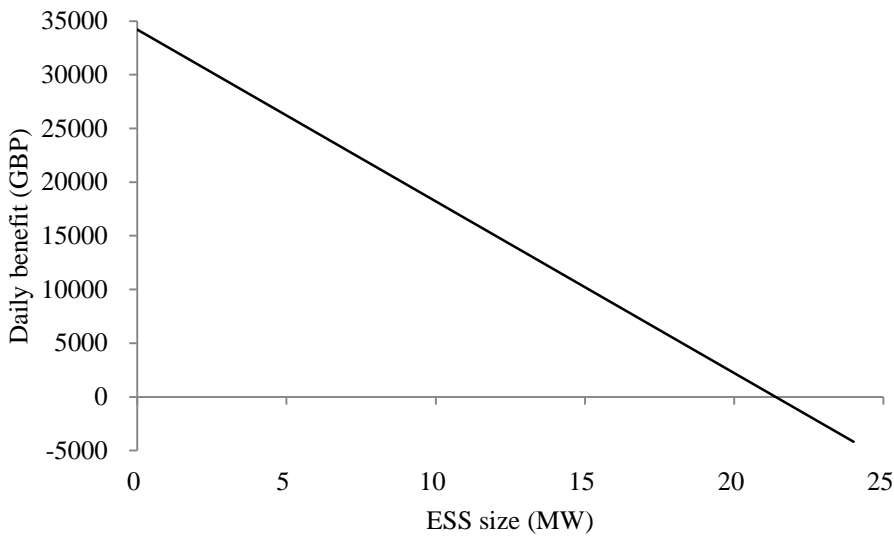

**Fig. 7.** Curve of daily benefit to ESS size

This curve is a straight line showing downward trend since the daily benefit can be derived as a linear equation of ESS size, as shown in (11) when the RES supply income is supposed to be a constant due to certain generation profile. When there is no ESS, all the benefit comes from the electricity selling income from RES. When the ESS size is smaller than 21MW, the LESS is beneficial with a minimum daily income of £614.

In contingency operation mode, the power sources are RES and ESS and the power demand are residential loads and EV charging demand. Fig. 8 provides the curve of loss-of-load to ESS size. In Fig. 8, the lost power in the most severe condition is considered.

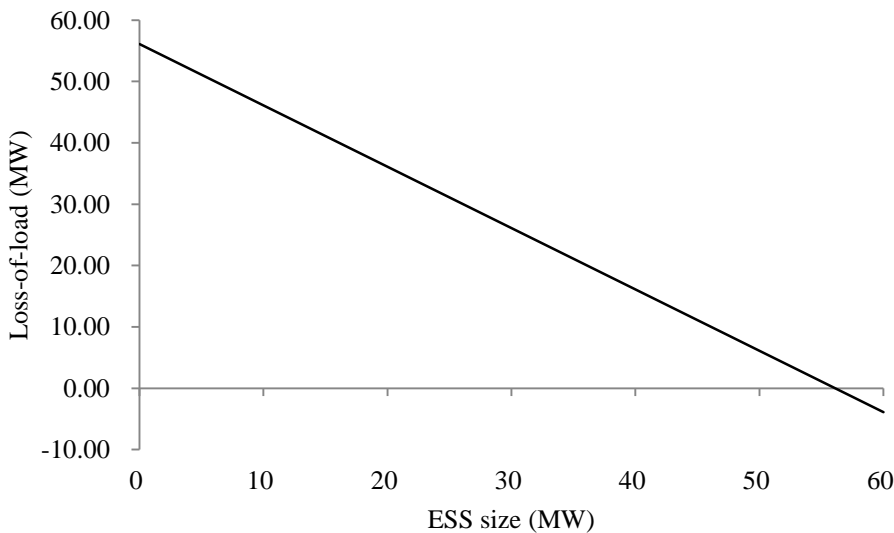
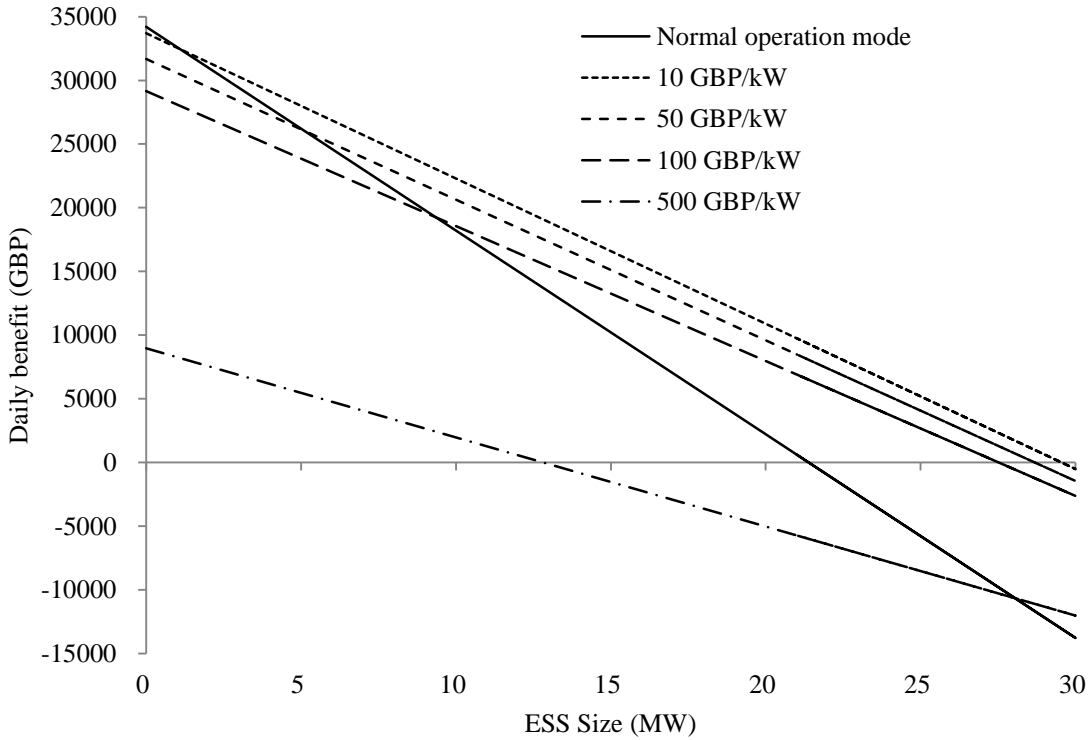

**Fig. 8.** Curve of loss-of-load to ESS size

As the discussion in Part 4.4 and from Fig. 8, when the ESS size is smaller than 57MW, there is loss-of-load. Therefore local supply cannot meet local demand since the generation in this network is relatively small-scale. However, taking into account the daily benefit in both operating modes and the loss-of-load, from (9) it can be derived that

$$S_{tot} = S - h_{tot} P_{tot} \quad (15)$$

where,  $S_{tot}$  is the total daily benefit;  $h_{tot}$  is the value of lost load (VoLL) [15], and  $P_{tot}$  is the loss-of-load expectation (LOLE) [16], [17]. Fig. 9 provides the total daily benefit with different ESS sizes under different levels of loss-of-load cost.



**Fig. 9.** Total daily benefit with different ESS sizes under different levels of VoLL

It can be obtained from Fig. 9 that under different loss-of-load cost levels, the optimal LESS sizes to make it sufficient for both operation modes are different. The crossing points in Fig. 9 refer to such sizes. The critical point, which makes the total daily benefit positive, is close to the zero axis with the LESS size to be  $P_{ESS} = 21\text{MW}$  and  $E_{ESS} = 504\text{MWh}$ , and the VoLL is £318/kW. The total benefit is £19 and the LESS is sufficient to charge all EVs. With higher VoLL and larger LESS size, the total benefit per day will be less.

However, based on the UK VoLL statistics [15], the VoLL is usually £10-20/kW, which is much lower than the VoLL at the critical point. Taking into account such amount of VoLL, the optimal sizes of LESS are listed in Table 4.

**Table 4** LESS optimisation results under different levels of VoLL

VoLL (£/kW)	$P_{ESS}$ (MW)	$E_{ESS}$ (MWh)	Daily benefit (£)	EV support capability
10	1.1	26.4	32,448	<18.0%
20	2.16	51.84	30,753	<35.3%

From Table 4 it can be concluded that with smaller VoLL, the optimal size of ESS is smaller and the total daily benefit is higher. The daily benefit mainly comes from the RES electricity sale income. However, with smaller ESS size, EVs cannot be sufficiently charged by the proposed LESS solution. The maximum percentages are about 18.0% under £10/kW VoLL and 35.3% under £20/kW VoLL.

## 5. Conclusions

This paper proposes ESS installation in the distribution system on the demand side in order to make local supply provision to meet local demand. A technical solution, called LESS, is proposed and the structure, requirements and optimal sizing of LESS have been presented. There are three operating modes for the LESS solution: 1) storage pack management, 2) normal operation mode, and 3) contingency operation mode. In the first mode, a flow chart of the storage pack management is provided. Tie-line regulation and emergency power supply as well as RES support are respected for normal operation and contingency operation, respectively. The proposed LESS is examined in real power distribution networks in N.I. and a future scenario in 2020 is considered. The loss-of-load evaluation is also presented.

In the paper, it is demonstrated that local storage could practically meet local demand in any perceived situation. During normal operation when the LESS is connected to the bulk power system, the power fluctuation in the tie line can be reduced. During contingency operation when the LESS is disconnected, the LESS is still powerful enough to support wind generation provision. Moreover, using the LESS in a practical context for EV road vehicles, charging provision for intermittent and stochastic connection (and disconnection) of vehicles is adequate without adverse impact on existing load. An optimal LESS size for a local (city) distribution network has been presented with  $P_{ESS} = 21\text{MW}$  and  $E_{ESS} = 504\text{MWh}$  when the VoLL is £318/kW, and the total benefit is £19. With lower VoLL and smaller



LESS, the total benefit will increase. By considering an actual value of VoLL in the UK, the optimal size of LESS is about 1.1-2.16 MW while the maximum EV support capability is about 18.0-35.3%.

The economic benefits of the proposed LESS scheme vary, as presented in this case study. Three areas of work in particular impact on the viability of the proposed scheme and are subject to ongoing and further research: 1) different electricity selling tariff in different time periods, 2) LESS charging duration, and 3) LESS sizes. The concept of a local storage scheme meeting local demand is better expressed during islanding since it is economically beneficial under this condition. However, this may not be the case when the local distribution system is connected to a bulk (transmission) power system. The LESS scheme is proposed as a viable and effective scheme for future networks where a flexible electricity market will operate using a purchase tariff that is available to a broad base of consumers.

This paper was supported by the Engineering and Physical Sciences Research Council (EPSRC) UK-China joint research consortium (EP/F061242/1), the Science Bridge Award (EP/G042594/1), Chinese Scholarship Council (CSC) and Queen's University Belfast, UK.

## 6. References

- [1] 'Renewable Energy Roadmap UK Update 2013', [https://www.gov.uk/government/uploads/system/uploads/attachment\\_data/file/255182/UK\\_Renewable\\_Energy\\_Roadmap\\_-\\_5\\_November\\_-\\_FINAL\\_DOCUMENT\\_FOR\\_PUBLICATION\\_.pdf](https://www.gov.uk/government/uploads/system/uploads/attachment_data/file/255182/UK_Renewable_Energy_Roadmap_-_5_November_-_FINAL_DOCUMENT_FOR_PUBLICATION_.pdf), accessed 22 January 2015
- [2] Zhou, B.W., Littler, T., and Wang, H.F.: 'The impact of vehicle-to-grid on electric power systems: a review', IET Renewable Power Generation Conference 2013, Beijing, China, September 2013, pp. 1-4
- [3] Du, W., Wang, H.F., Cheng, S., Wen, J.Y., and Dunn, R.: 'Robustness of damping control implemented by Energy Storage Systems installed in power systems', Int. J. Electr. Power Energy Syst., 2011, **33**, (1), pp. 35-42
- [4] Ribeiro, P. F., Johnson, B. K., Crow, M. L., Arsoy, A. and Liu, Y.: 'Energy storage systems for advanced power applications', Proc. IEEE, 2001, **89**, (12), pp. 1744-1756
- [5] Ter-Gazarian, A. G.: 'Energy Storage for Power Systems'(IET Power and Energy Series 63, 2011, 2 edn. )
- [6] Cai, H., Du, W., Yu, X. P., *et al.*: 'Day-ahead Optimal Charging/Discharging Scheduling for Electric Vehicles in Micro-Grids', IET Renewable Power Generation Conference 2013, Beijing, China, September 2013, pp. 1-4
- [7] Wang, S.Y., and Yu, J.L.: 'Optimal sizing of the CAES system in a power system with high wind power penetration', Int. J. Electr. Power Energy Syst., 2012, **37**, (1), pp. 117-125
- [8] Divya, K. C., and Østergaard, J.: 'Battery energy storage technology for power systems—An overview', Electric Power Systems Research, 2009, **79**, (3), pp. 511-520
- [9] Qian, K., Zhou, C., Allan, M., and Yuan, Y.: 'Modeling of load demand due to EV battery charging in distribution systems', IEEE Trans. Power Syst., 2011, **26**, (2), pp. 802-810

- [10] Zhou, B.W., Littler, T., and Foley, A.: 'Electric Vehicle Capacity Forecasting Model with Application to Load Levelling', IEEE PES General Meeting 2015, Denver, CO, July 2015, pp. 1-5
- [11] IEC 62196-2: 'Plugs, socket-outlets, vehicle connectors and vehicle inlets - Conductive charging of electric vehicles - Part 2: Dimensional compatibility and interchangeability requirements for a.c. pin and contact-tube accessories', 2011
- [12] 'System Demand', <http://www.eirgrid.com/operations/systemperformancedata/systemdemand/>, accessed 22 January 2015
- [13] 'Electricity Capacity Assessment Report 2013', <https://www.ofgem.gov.uk/ofgem-publications/75232/electricity-capacity-assessment-report-2013.pdf>, accessed 22 January 2015
- [14] Liu, Z., Wen, F., and Ledwich, G.: 'Optimal planning of electric-vehicle charging station in distribution systems', IEEE Trans. Power Del., 2013, **28**, (1), pp. 102-110
- [15] 'The Value of Lost Load (VoLL) for Electricity in Great Britain', [https://www.gov.uk/government/uploads/system/uploads/attachment\\_data/file/224028/value\\_lost\\_load\\_electricity\\_gb.pdf](https://www.gov.uk/government/uploads/system/uploads/attachment_data/file/224028/value_lost_load_electricity_gb.pdf), accessed 22 January 2015
- [16] Van Schijndel, A., Wetzer, J.M., Wouters, P.A.A.F.: 'Forecasting Transformer Reliability', 2006 IEEE Conference on Electrical Insulation and Dielectric Phenomena, Kansas City, MO, October 2008, pp. 577-582
- [17] Feng, D.: 'Life Expectancy Investigation of Transmission Power Transformers', Ph.D. thesis, University of Manchester, 2013