

Parametric CAD model based shape optimization using adjoint functions

Agarwal, D., Kapellos, C., Robinson, T. T., & Armstrong, C. G. (2016). Parametric CAD model based shape optimization using adjoint functions. 11th ASMO UK/ISSMO/NOED2016: International Conference on Numerical Optimisation Methods for Engineering Design, Munich, Germany.

Queen's University Belfast - Research Portal:

[Link to publication record in Queen's University Belfast Research Portal](#)

Publisher rights

Copyright 2016 The Authors

General rights

Copyright for the publications made accessible via the Queen's University Belfast Research Portal is retained by the author(s) and / or other copyright owners and it is a condition of accessing these publications that users recognise and abide by the legal requirements associated with these rights.

Take down policy

The Research Portal is Queen's institutional repository that provides access to Queen's research output. Every effort has been made to ensure that content in the Research Portal does not infringe any person's rights, or applicable UK laws. If you discover content in the Research Portal that you believe breaches copyright or violates any law, please contact openaccess@qub.ac.uk.

Parametric CAD model based shape optimization using adjoint functions

11th ASMO UK / NOED2016 / ISSMO Conference

[Dheeraj Agarwal](#)
d.agarwal@qub.ac.uk

Christos Kapellos
christos.kapellos@volkswagen.de

Trevor T. Robinson
t.robinson@qub.ac.uk

Cecil G. Armstrong
c.armstrong@qub.ac.uk



Contents

- Motivation
- CAD parameterisation
- Design Velocity
- Optimization results
- Conclusions

Motivation

- To enable the use of parameters which define the shape in a feature-based CAD model as optimization variables.
- To present an efficient methodology for the calculation of gradients for CAD based design variables.
- To present an efficient approach for gradient based optimization using adjoint functions and CAD variables in presence of constraints.

Parametric CAD model (S-bend)

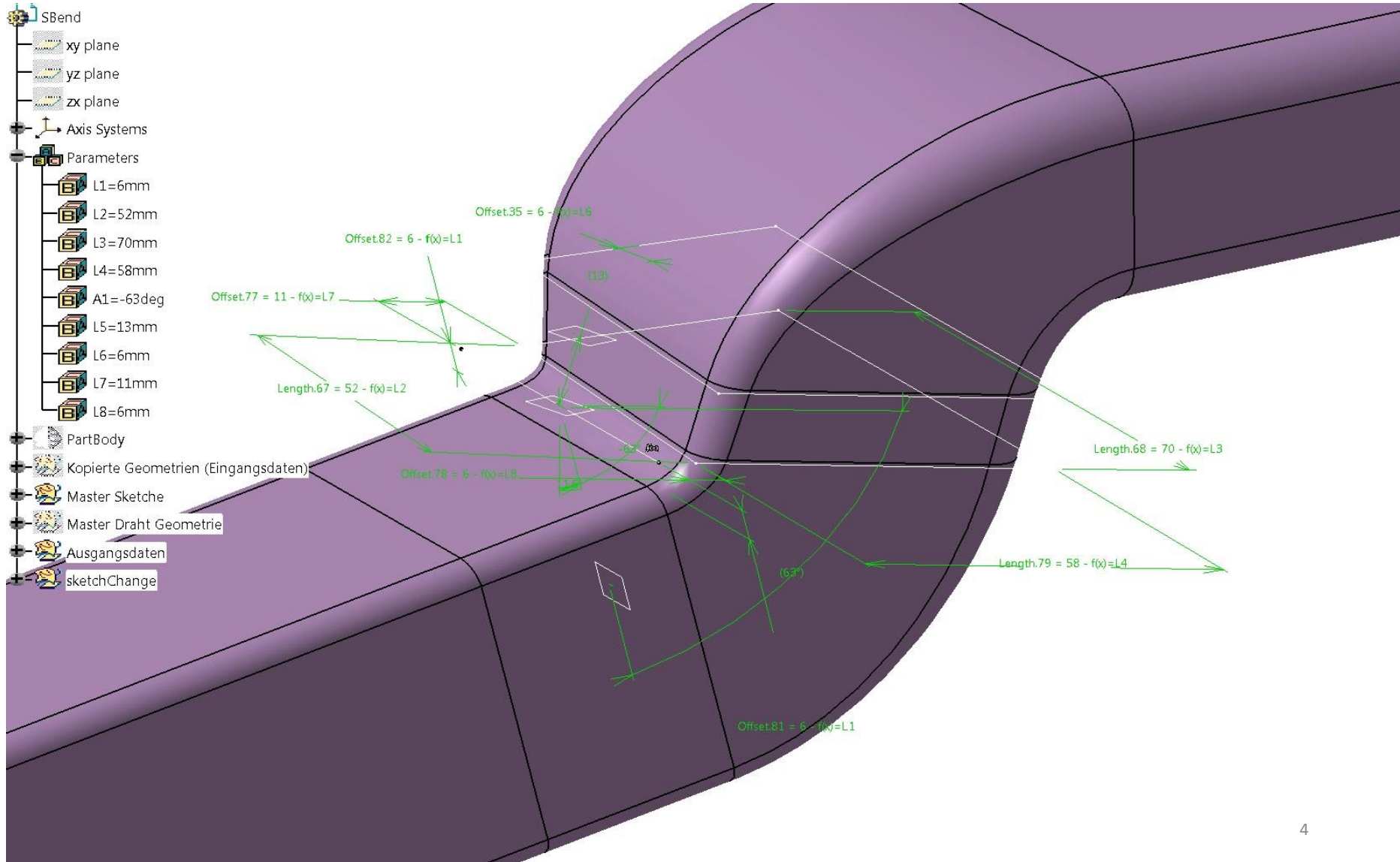

Parametric CAD model (wing)

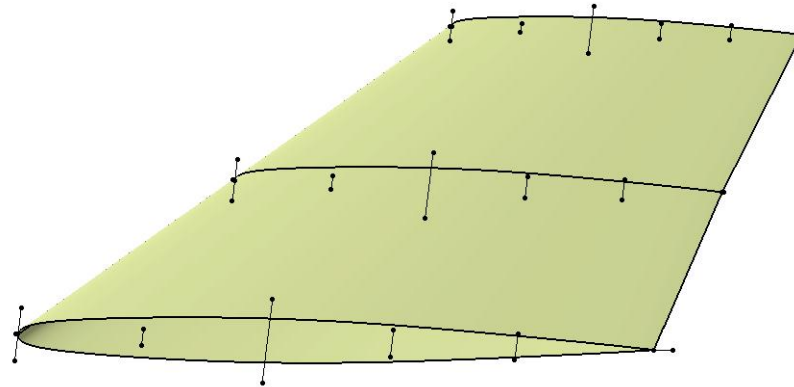
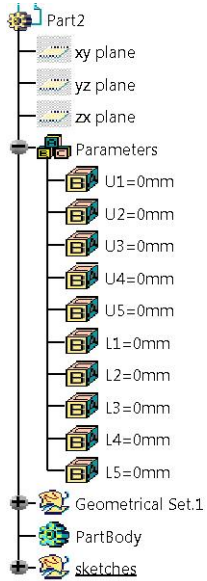

Bezier curve

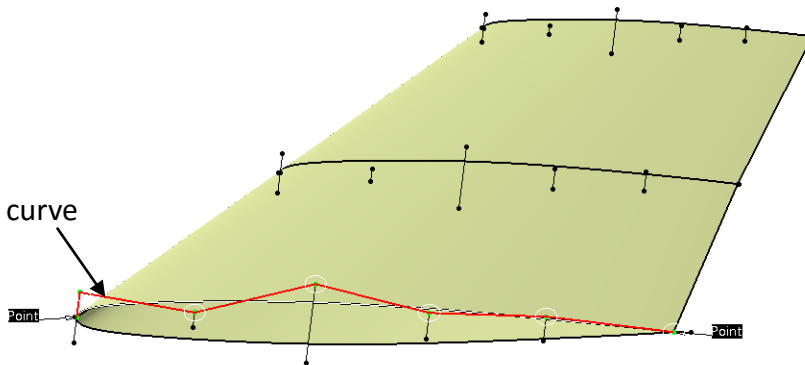

Gradient Computation

$$\underbrace{\begin{Bmatrix} \frac{\partial J}{\partial A_1} \\ \frac{\partial J}{\partial A_2} \\ \vdots \\ \frac{\partial J}{\partial A_n} \end{Bmatrix}}_{\text{Gradients}} = \underbrace{\begin{bmatrix} \frac{\partial x}{\partial A_1} & \cdots & \frac{\partial x_m}{\partial A_1} \\ \vdots & \ddots & \vdots \\ \frac{\partial x_1}{\partial A_n} & \cdots & \frac{\partial x_m}{\partial A_n} \end{bmatrix}}_{\text{Design Velocities}} \underbrace{\begin{Bmatrix} \frac{\partial J}{\partial x_1} \\ \frac{\partial J}{\partial x_2} \\ \vdots \\ \frac{\partial J}{\partial x_m} \end{Bmatrix}}_{\text{Surface sensitivities}}$$

- $\frac{\partial J}{\partial A_i}$ - **Gradients**
- $\frac{\partial x_j}{\partial A_i}$ - **Design Velocities**
- $\frac{\partial J}{\partial x_j}$ - **Surface sensitivities**

Gradient Computation

$$\left\{ \begin{array}{c} \frac{\partial J}{\partial A_1} \\ \frac{\partial J}{\partial A_2} \\ \vdots \\ \frac{\partial J}{\partial A_n} \end{array} \right\} = \begin{bmatrix} \frac{\partial x}{\partial A_1} & \dots & \frac{\partial x_m}{\partial A_1} \\ \vdots & \ddots & \vdots \\ \frac{\partial x_1}{\partial A_n} & \dots & \frac{\partial x_m}{\partial A_n} \end{bmatrix} \left\{ \begin{array}{c} \frac{\partial J}{\partial x_1} \\ \frac{\partial J}{\partial x_2} \\ \vdots \\ \frac{\partial J}{\partial x_m} \end{array} \right\}$$

Surface sensitivities

- $\frac{\partial J}{\partial A_i}$ - **Gradients**
- $\frac{\partial x_j}{\partial A_i}$ - **Design Velocities**
- $\frac{\partial J}{\partial x_j}$ - **Surface sensitivities**

Adjoint Sensitivity

- Adjoint surface sensitivity represents the derivative of the objective function with respect to surface perturbation at each mesh node.

$$\phi = \frac{dJ}{dX_s}$$

- The adjoint sensitivity map is provided as values of ϕ on a mesh of the boundary of the model.

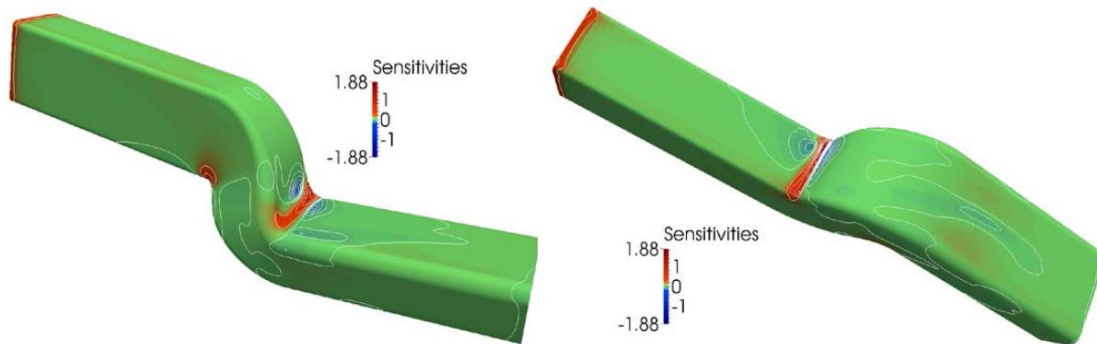

Adjoint sensitivities contour. To minimize the objective function (dissipated power) the surface has to be pulled out at positive values (warm colours) or pushed in (cold colours). Areas coloured green have practically no impact on the objective function

Gradient Computation

$$\left\{ \begin{array}{c} \frac{\partial J}{\partial A_1} \\ \frac{\partial J}{\partial A_2} \\ \vdots \\ \frac{\partial J}{\partial A_n} \end{array} \right\} = \underbrace{\left[\begin{array}{ccc} \frac{\partial x}{\partial A_1} & \cdots & \frac{\partial x_m}{\partial A_1} \\ \vdots & \ddots & \vdots \\ \frac{\partial x_1}{\partial A_n} & \cdots & \frac{\partial x_m}{\partial A_n} \end{array} \right]}_{\text{Design Velocities}} \left\{ \begin{array}{c} \frac{\partial J}{\partial x_1} \\ \frac{\partial J}{\partial x_2} \\ \vdots \\ \frac{\partial J}{\partial x_m} \end{array} \right\}$$

- $\frac{\partial J}{\partial A_i}$ - **Gradients**
- $\frac{\partial x_j}{\partial A_i}$ - **Design Velocities**
- $\frac{\partial J}{\partial x_j}$ - **Surface sensitivities**

Design Velocity

- Measure of geometric shape change in response to a parameter change.
- Design velocity can be defined as the normal component of shape displacement on the boundary of the model.

$$V_n = \delta X_s \cdot \hat{n},$$

where δX_s is the movement of surface nodes and \hat{n} is the outward unit normal.

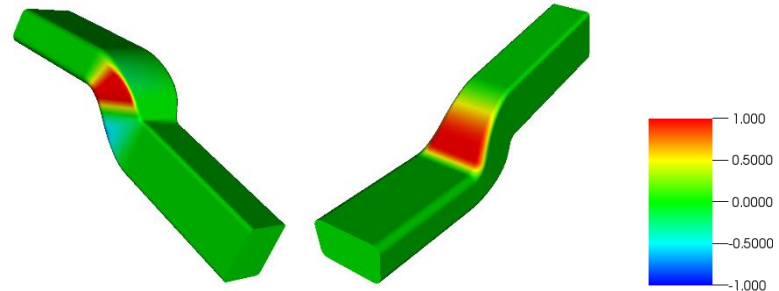
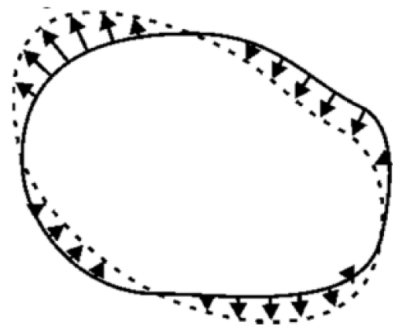

Design Velocity Calculation

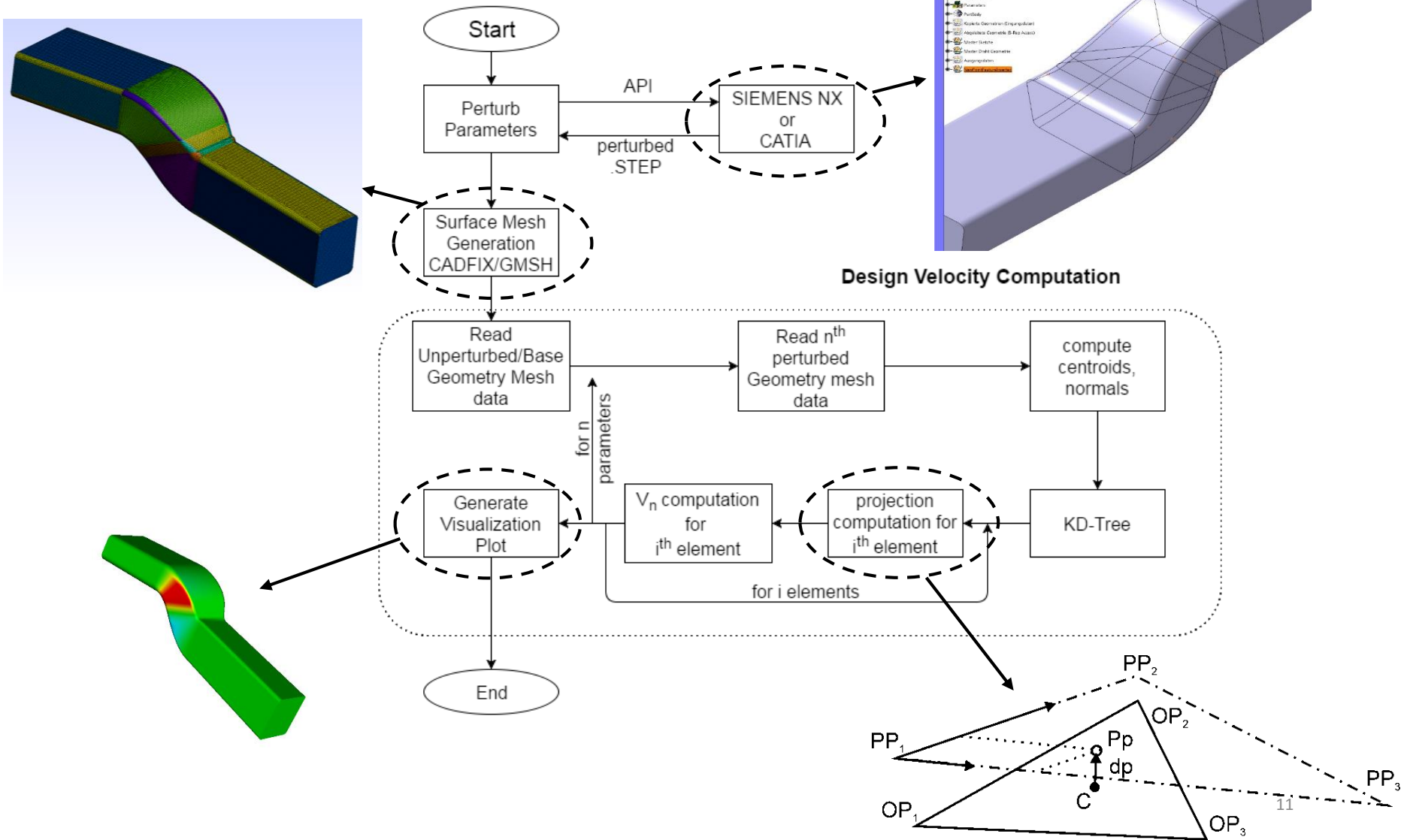
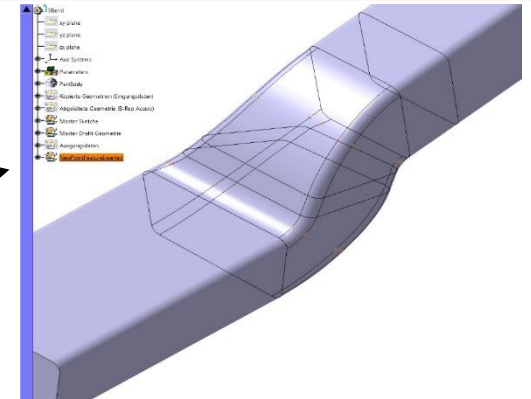
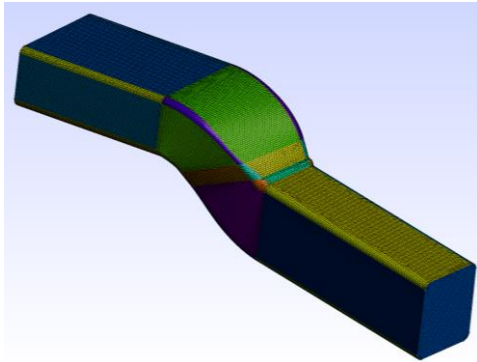

Design Velocity Validation

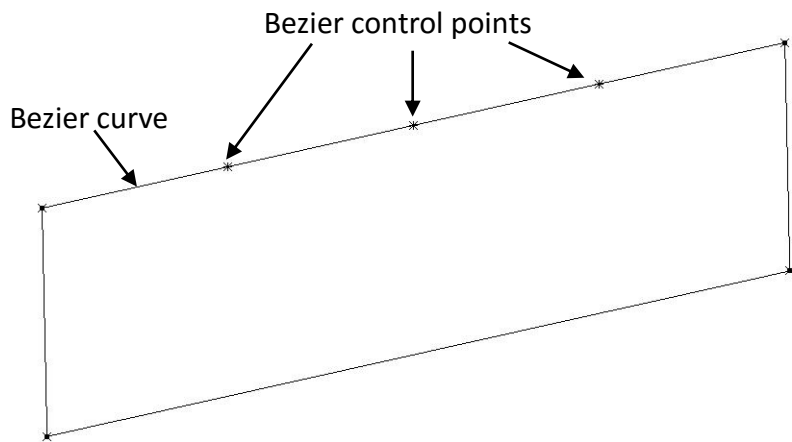
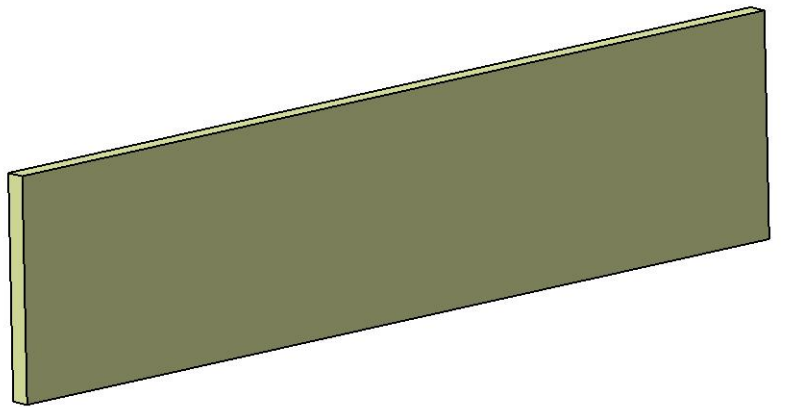

$$X(t) = \sum_{i=0}^n P_i B_{in}(t)$$

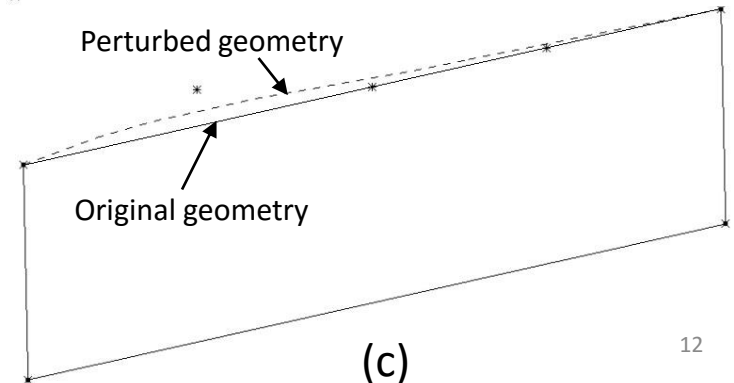
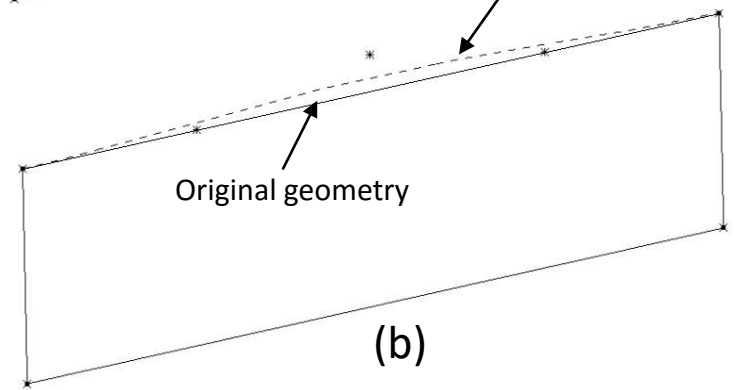
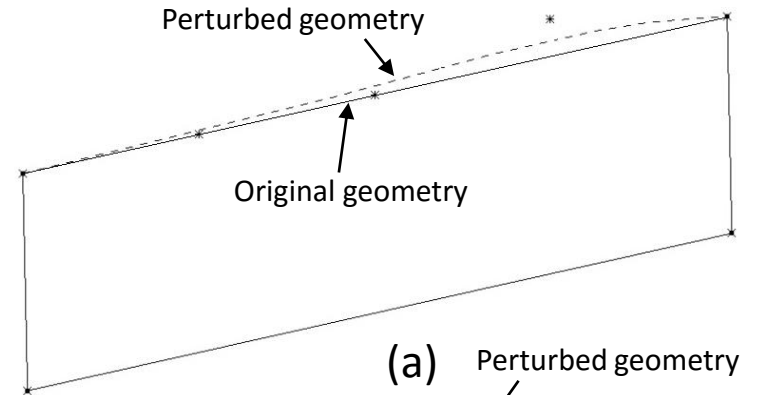

Design Velocity Validation

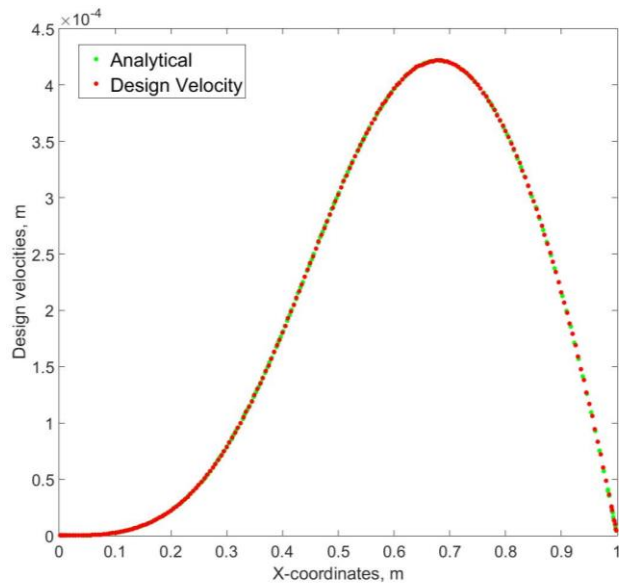

(a)

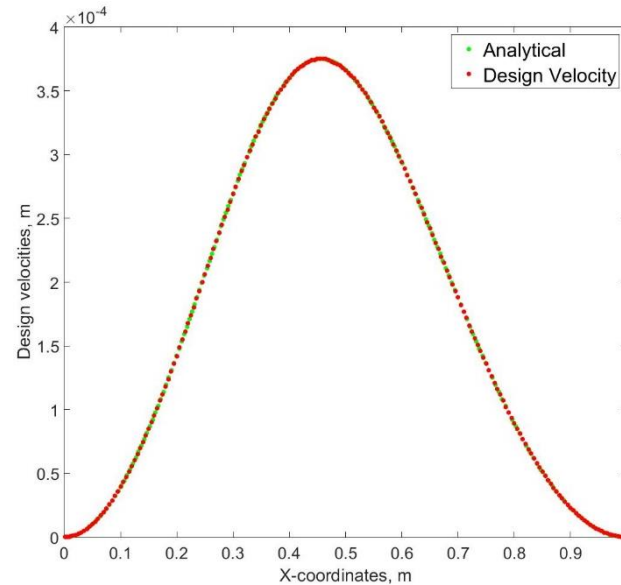

(b)

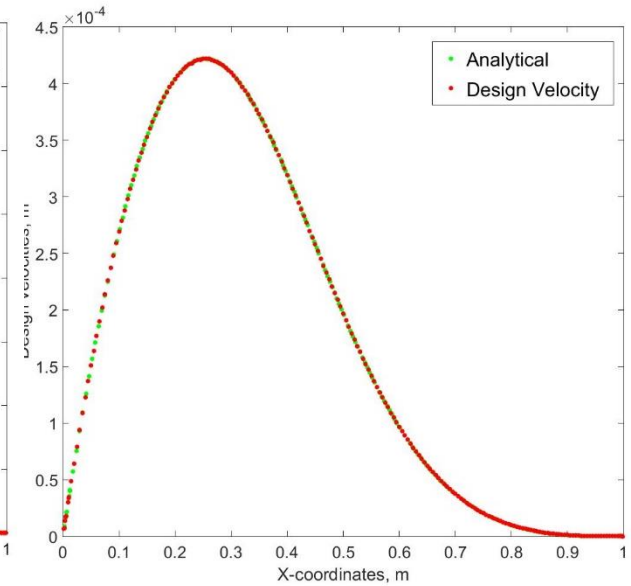

(c)

For perturbation of 10^{-3} m the maximum error is of the order of 10^{-7} m

Design Velocity contours (wing)

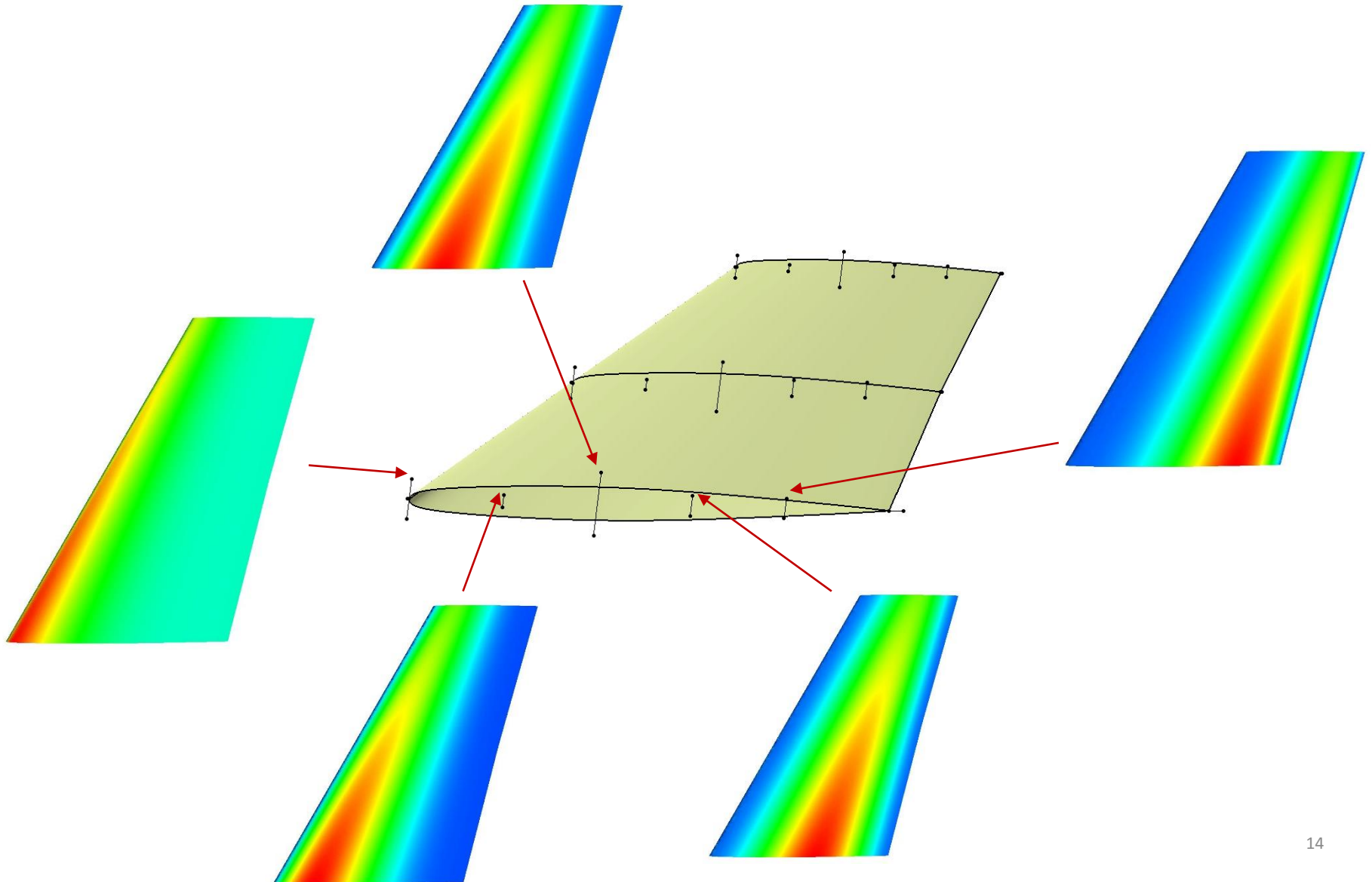

Design Velocity (S-Bend)

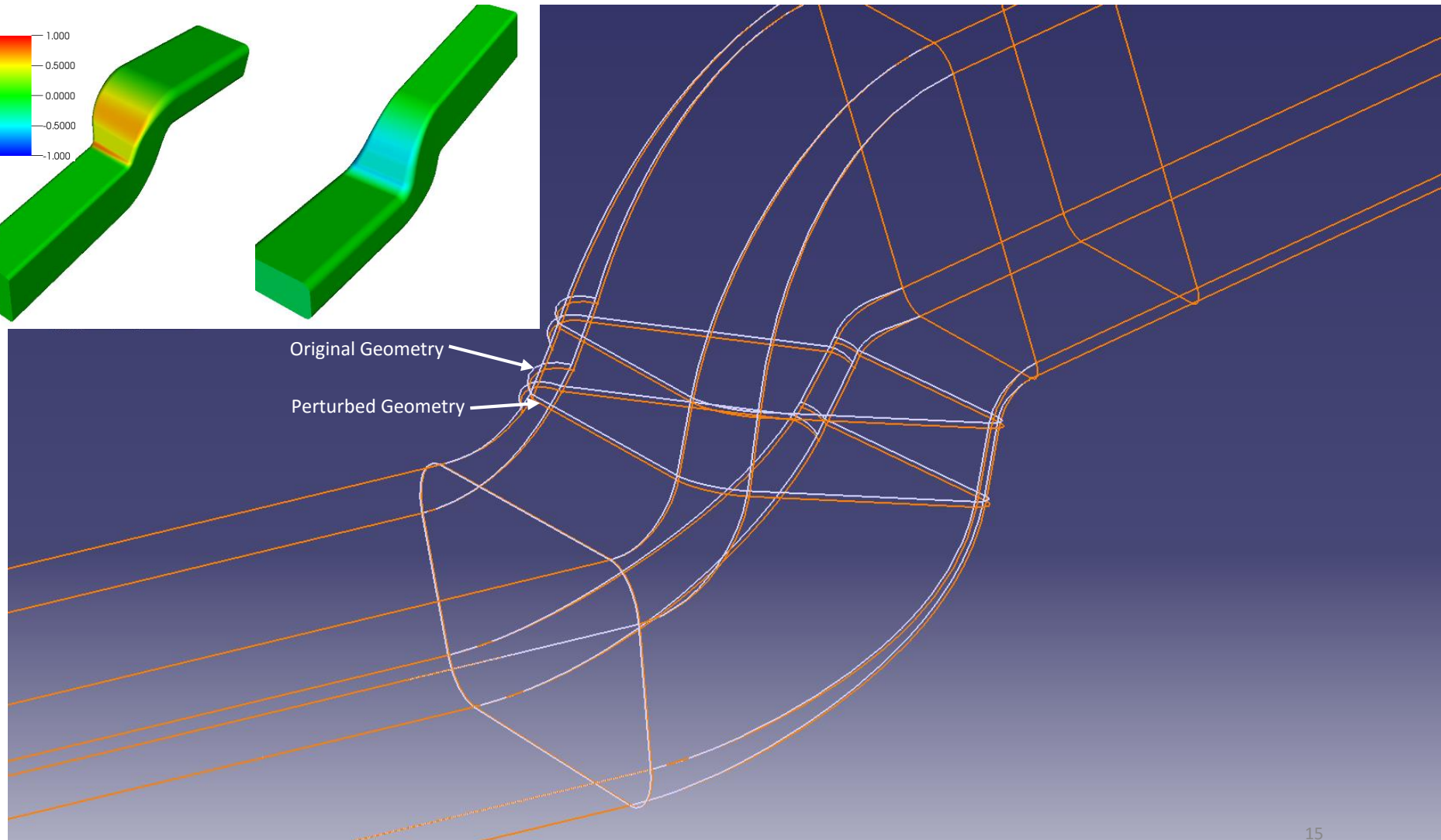
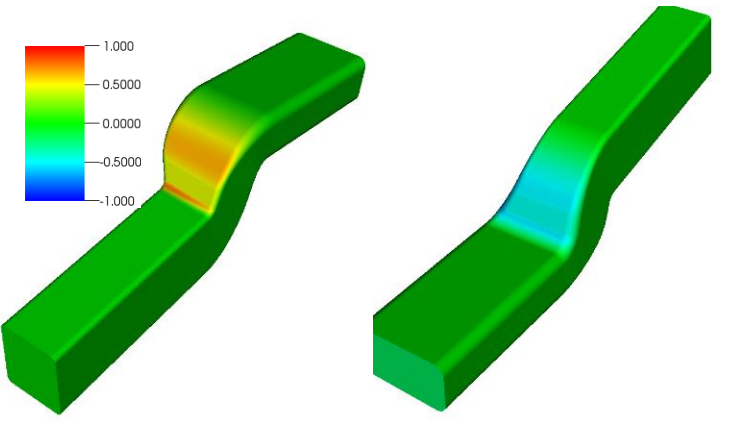

CAD based Optimization

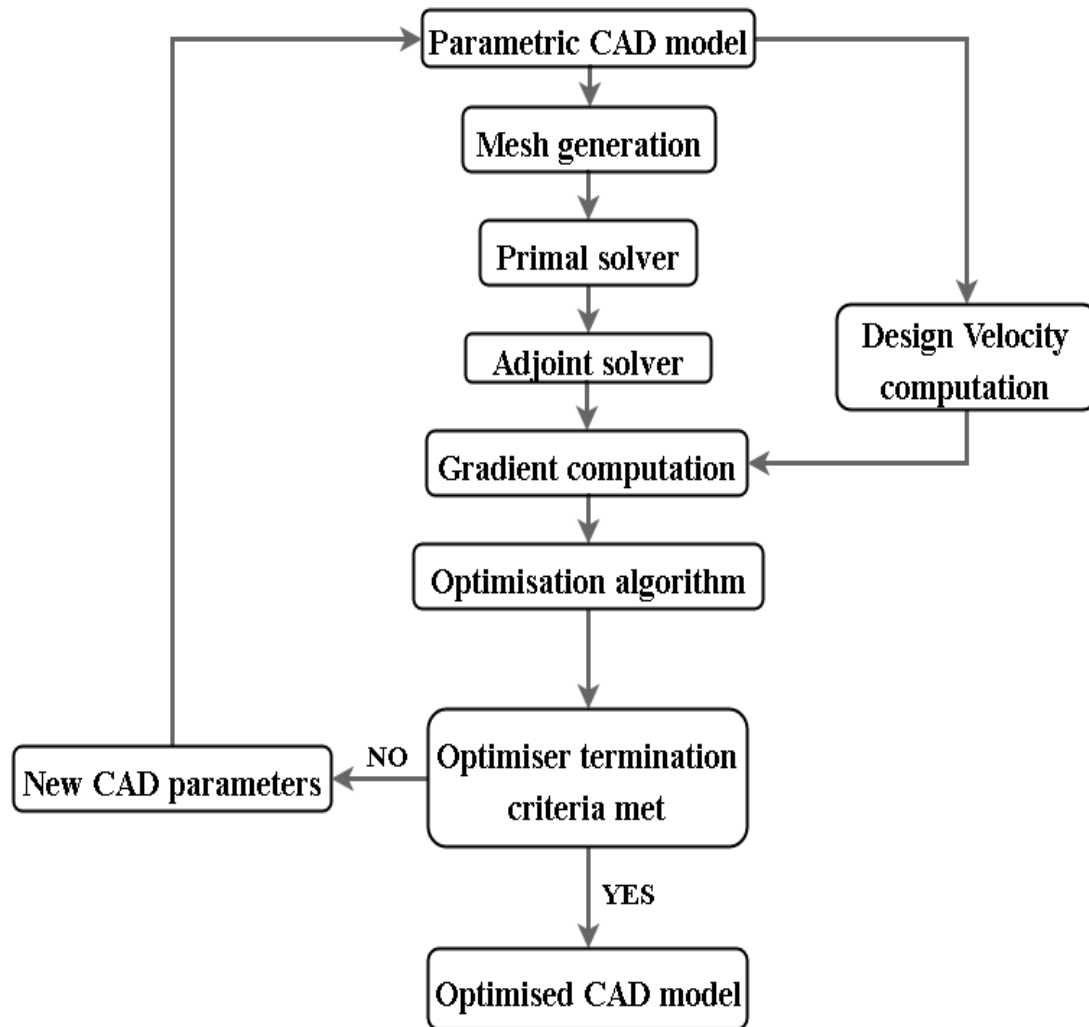

Problem Formulation

Objective Functions :

1) dissipated power $J = \int_S \psi \left(p + \frac{1}{2} v^2 \right) dS$

2) uniformity at the outlet $J = \int_{outlet} (v - v_{mean})^2 dS$

Flow conditions

- Laminar flow, Re=350
- Inlet velocity $u=0.1\text{m/s}$
- Structured mesh, 710,000 cells

Design Variables

9 design parameters created in CATIA V5 controlling the S-bend portion of the duct.

Validation

- Predictions of change in objective function against CFD analysis computations
- Slope of linear approximation reflects the over prediction of the method (~ 1.4)

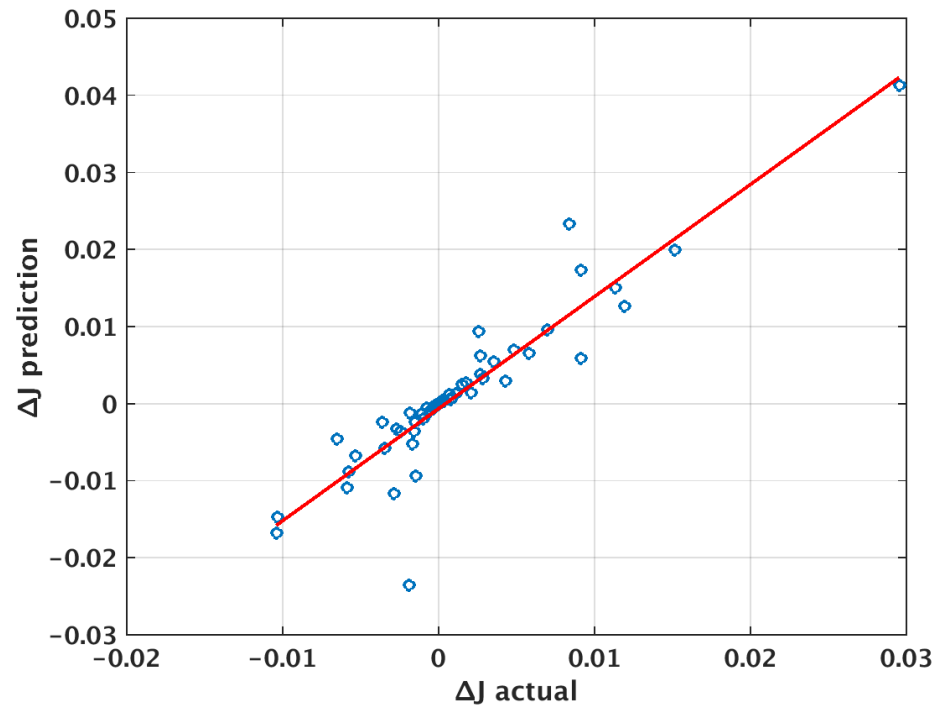

Unconstrained Optimization

Targeting at dissipated power minimisation

- BFGS algorithm
- 5.1% reduction of objective function

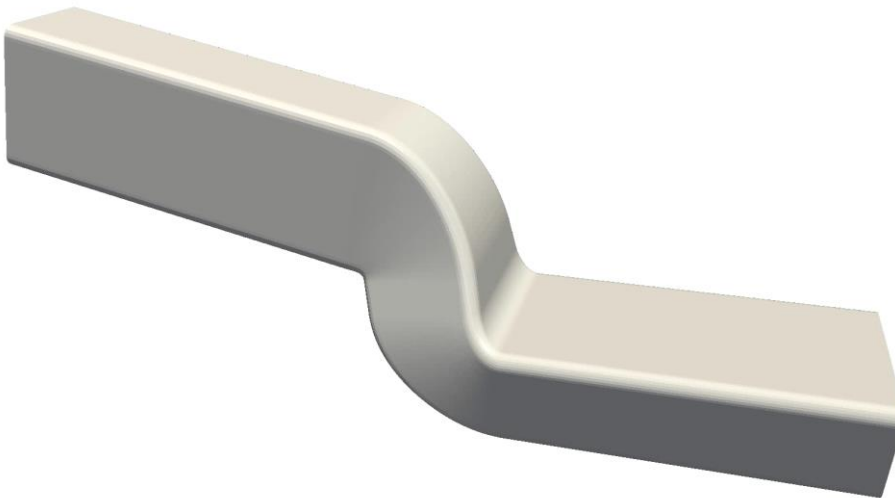

Geometry during the optimisation cycles

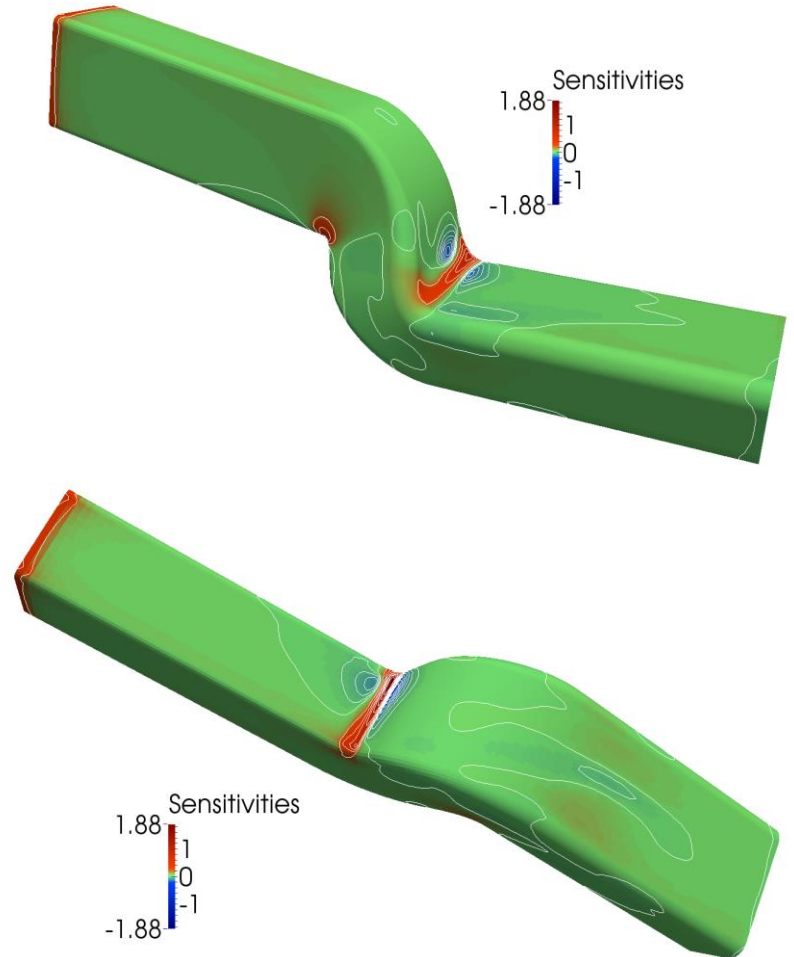

Adjoint sensitivities: Pull out red areas, push in blue areas

Unconstrained Optimization

Targeting at outlet uniformity maximisation

- BFGS algorithm
- 2% reduction of objective function
- Further reduction constrained by parameters limits

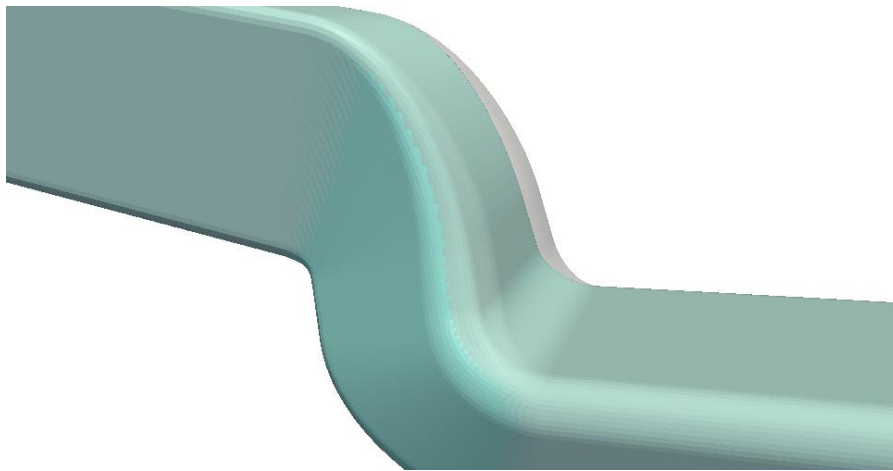

Comparison between starting geometry (transparent) and optimised geometry (cyan)

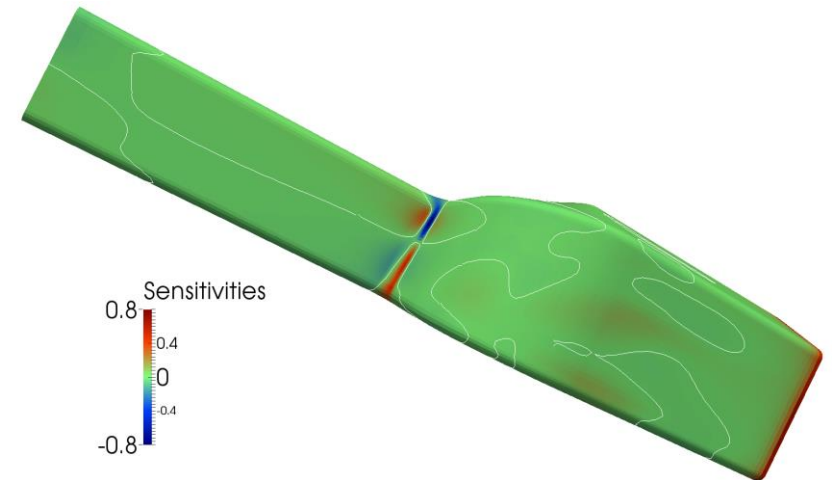
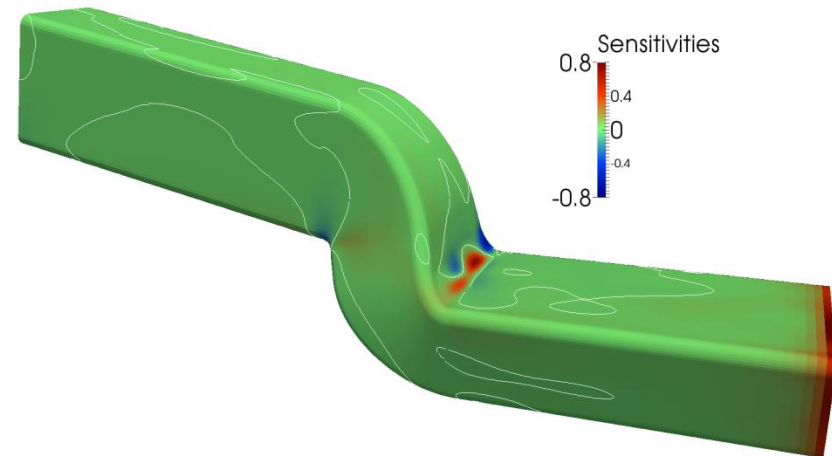

Adjoint sensitivities: Pull out red areas, push in blue areas

Constrained Optimization

Targeting at outlet uniformity maximisation
with fixed power dissipation losses

- 5% Reduction in objective function
- Constraint imposed with the Augmented Lagrangian Method using in-house code

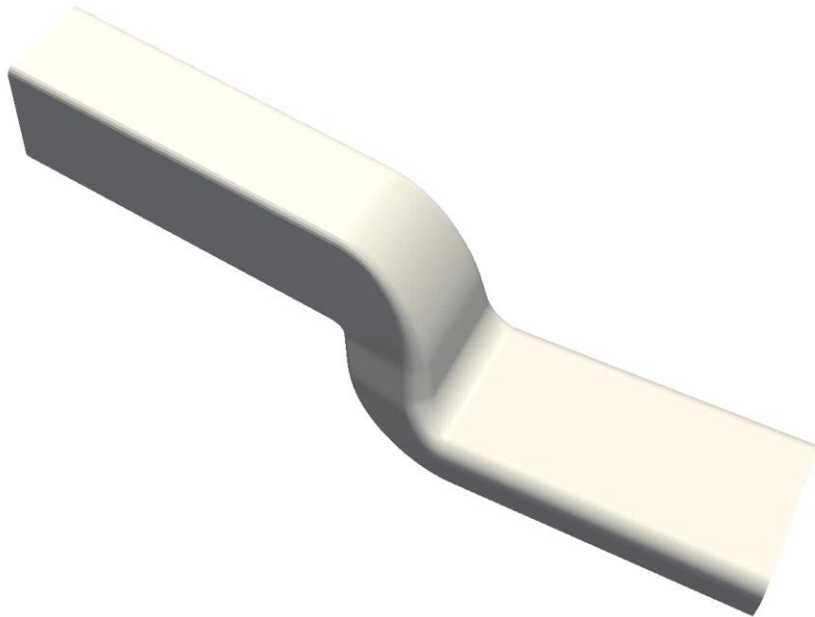

Geometry during the optimisation cycles

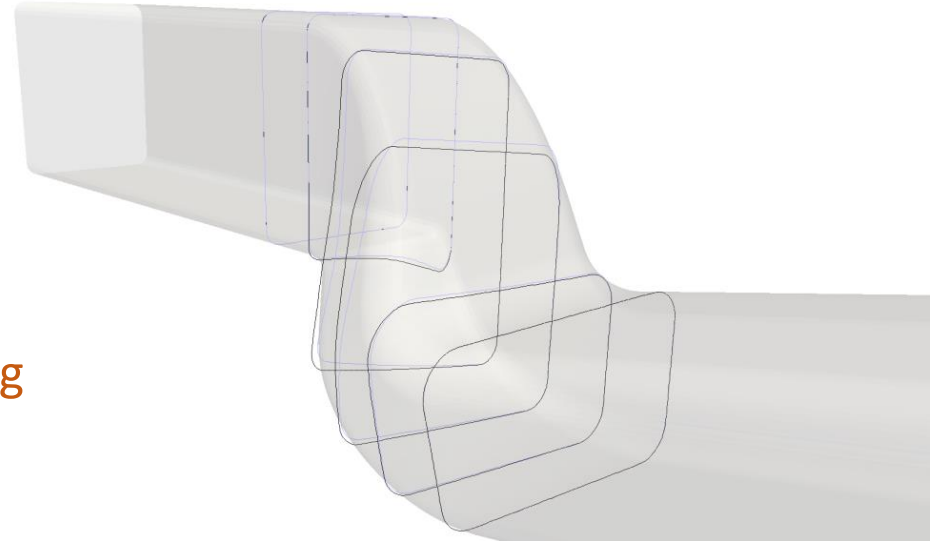

Comparison of the optimised geometries derived by the unconstrained (transparent, magenta lines) and constrained (black lines) optimisation

Conclusion

- An efficient and robust method has been developed for calculating geometrical movements or design velocities for different CAD parameters.
- The developed approach is linked with adjoint sensitivities to use CAD parameters directly in the optimization loop.
- Optimization of S-Bend duct using parameters defined in CATIA V5 have been shown.
- The optimization for two different objective functions i.e. minimizing power dissipation and maximizing flow uniformity at the outlet is achieved.
- Implementation of flow constraints have been shown using Augmented Lagrangian method.

Future Works

- Formulate methodologies which can be used to automatically parameterize the CAD model using existing feature free.
- Automatically adding the optimum new CAD features to CAD model in order to improve the manner in which the shape can update.
- To rate the effectiveness of CAD parameters and find the most effective parameter set to be used in optimization.
- Consider the constraints imposed on a design from adjacent components in the product assembly, which are currently not robustly defined.

Acknowledgement

This work has been conducted within the **IODA** project on
“Industrial Optimal Design using Adjoint CFD”

<http://ioda.sems.qmul.ac.uk/>

IODA has received funding from
the European Union’s HORIZON
2020 Framework Programme for
Research and Innovation under
Grant Agreement No. 642959.

