

Maximizing Profit in Reverse Supply Chain

Ehsan Khansalar¹, Mahmood Lari Dashte Bayaz¹ & Reza Safari²

¹ Kingston Business School, Kingston University, London, UK

³ Department of Accounting and Economics, Islamic Azad University, Qaenat Branch, Birjand, Iran

Correspondence: Ehsan Khansalar, Kingston Business School, Kingston University, London, UK. E-mail: khansalarehsan@yahoo.com

Received: August 17, 2015

Accepted: September 7, 2015

Online Published: October 26, 2015

doi:10.5539/ibr.v8n11p4111

URL: <http://dx.doi.org/10.5539/ibr.v8n11p111>

Abstract

We try to find a linear analytical model to evaluate cost maximization using reverse logistics network in recycle industry, which reduces total cost of reverse logistics. In industries that production costs or percentage of recurred goods are significantly high, reverse logistics is so important. The purpose of this research is presenting a reverse logistics model and also a mathematical model to minimize costs and maximize benefits in recycle industry. Presented model in this research is a multi-variable system which has some constraints. This model helps organizations to use appropriate production strategies.

Keywords: supply chain, reverse logistics, garbage, recycle

1. Introduction

Today, environment and its maintenance have become the most vital challenge for people, so, one of the most important citizenship problems is growing garbage production trend. It should be find a cure to solve this problem and take action by using appropriate ways for returning these materials to production cycle, otherwise in near future, we will face to environmental problems (Tabriz et al., 1390).

One the modern interests in logistics management is recycling products. In this procedure, products approaching to their useful life will be purchased from final consumers and after assembly, recyclable parts will be returned to life cycle (Altipamack et al., 2009). Reverse logistics network part of supply chain-is “exact, correct transport of useful and usefulness products from last consumers to appropriate unit by means of supply chain”, it can be said that, reverse logistics is movement and transport of products which are not returnable to supply chain. Designing and implementation of reverse logistics network for returned products not only reduce transportation costs but also increase customers loyalty (Lee et al., 2009).

Reverse logistics and recursive process management is among topics discussed in logistics and supply chain management of different industries; which was not considered in our country. During last two decades, many companies and industries in developed countries initiated analysis in this domain, and considered reverse logistics an important process in their supply chain. Recently, some of developed countries has received ISO license for recursive processes. Today, industrial, governmental, economical and service organizations in developed countries have focused on reverse logistics and supply chain, this trend improves real economical costs and supports environmental concerns. This focus is growing in all markets like industrial, high technological units and products. In classical product flow, industrial managers focus on control and management of direct or forward flow of material and products, which mostly moves from suppliers to producers, distributors, retailers and at last to consumers. But in many industries, there is another important flow in supply chain, which is reverse, in this flow, products are returned from low levels to high levels. Reverse logistics attempts to evaluate reverse or backward flows in supply chains (Noori et al., 1388).

Reverse logistics management and supply chains of closed rings are most vital aspects of each business, which require production, service distribution, and support of any product. Life cycle of products is short, so return products strategies with fast providing services to consumers are defined and most focuses are on recursive management, modification and restocking. Governmental green laws which are associated with returning and removing electronic wastes and hazardous materials force managers to look more exactly at reverse logisticsprocess (Noori et al., 1388).

Although many activities can be considered in reverse logistics, but some of the most important activities in reverse logistics include; repair, replacement, renewal, reconstruction, recycle and repurchasing. Reverse logistics is not limited to recycle, it also includes redesigning packages in order to use less material or decrease energy and pollution of transporting products, this domain is called “green logistics” (Sirostova, 2008).

In order to understand the significance of reverse logistics in reducing cost prices of products, analyses conducted in USA can be mentioned. These analyses show that about 4% of logistics costs in each company is paid for reverse logistics, this percentage is high in companies or industries which their products have low quality (Low, 2007).

It should be mentioned that reverse logistics depends on industry nature; but its costs are so high. Generally reverse logistics is very important in industries which their product costs of recessives are high. Analyses show that 50% of products should be duplicated or reformed during construction process. These total recessives result in significant costs. By knowing that, costs of a recessive can be more than 2-3 times more than its external transportation cost, necessity to consider reverse logistics in industries becomes obvious for us (Altıparmak et al., 2009).

Flishman et al. (2001) expanded general model to a multi-product, multi-capacity reverse distribution network with uncertainty for demand conditions, they found that most suggested models are case based, so they cannot be generalized. Flishman et al. (2001) analyzed general reverse logistics network, in this network capacity limitations, multi-product management uncertainty for product demands and recessives have been considered, they developed a mixed integer formulation.

Lee and Dung (2009) designed a general reverse logistics network to expand Flishman et al. (2000) suggested model by integration recovery options like repair and reconstruction, they presented a MILP model. Zhu and Dung (2008) developed a random model to design multi-layer, multi-period reverse-forward logistics network, their purpose was maximization total expected profit. In this article, a decision making simple mixed integer linear programming (SMILP) will be presented, which is a random multi-step planning. Alseyd et al. (2010) presented a scenario based random optimization to consider uncertainties in designing integrated reverse-forward logistics network. This network is a closed-loop integrated reverse-forward logistics network that is presented to minimize total cost by means of a SMILP model. Pishvayi et al. (2009) developed a two-purpose MINLP model to minimize total cost and maximize logistics network responding, they also suggested an algorithm based heuristic to solve the model.

Min et al. (2005) developed a multi-product, multi-layer model which is based on “lagrangean relaxation”. Min et al. (2006) presented a mixed integer linear programming model to minimize costs. They used a binary genetic algorithm to solve this model.

Kim et al. (2006) developed a general framework for reconstruction, the aim of this framework was to help suggested mathematical model to make decision about the number of pieces should be purchased from supplier and number of products should be used in each production center.

During few last years, interests to account environmental concerns and growth of opportunities for saving costs and sources or revenue improvement from recessives, have encouraged researchers to evaluate reverse logistics. Several works have been done to design logistics networks which include different models of optimization and positioning facilities based on integer programming. Model suggested in this research attempts to determine how can design a model using reverse logistics to maximize profit?

Related Research

- 1-Making a reverse logistics model to minimize costs and maximize profit in recycle.
- 2-Suggesting a mathematical model to minimize costs and maximize profit in recycle.

2. Method

This research is an applied one and its nature is descriptive, because describes conditions and relations, also it studies current situation of discussed topics.

For theoretical part, data has been collected literarily and for other parts, this has been done by field research. Computation has been done by suggested model and reverse logistics.

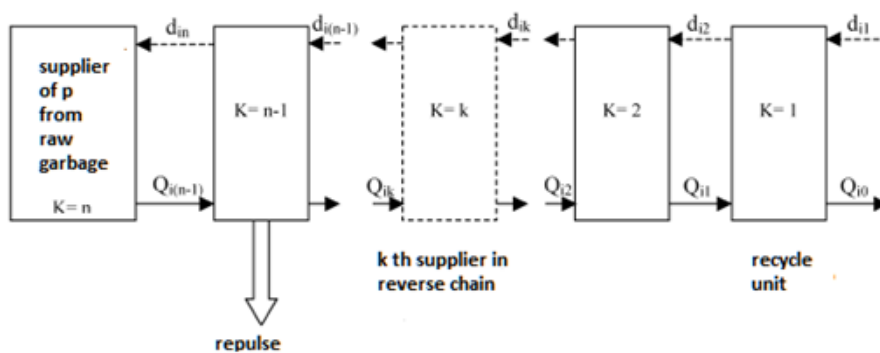

Figure 1. Conceptual reverse logistics model for garbage recycle (Rooyesh et al., 2000)

Mathematical model:

$$\begin{aligned}
 & [T_3 \times l_3 \times \sum_{i=1}^3 Q_{i3} + \sum_{i=1}^2 S_i \times Q_{i3} + \sum_{i=1}^2 h_{i3} \times \{b_{i3}(0) + Q_{i3} - Q_{i2}\}] + D \times \left\{ \sum_{i=1}^3 Q_{i3} - \sum_{i=1}^2 Q_{i3} \right\} \\
 & + \left[\sum_{i=1}^2 t_{i2} \times l_2 \times Q_{i2} + \sum_{i=1}^2 h_{i2} \times \{b_{i2}(0) + Q_{i2} - Q_{i1}\} \right] \\
 & + \left[\sum_{i=1}^{i=T} t^{i7} \times l^7 \times \delta^{i7} + \sum_{i=1}^{i=T} C^{int} \times \delta^{i0} + \sum_{i=1}^{i=T} y^{i7} \times \{p^{i7}(0) + \delta^{i7} - \delta^{i0}\} \right]
 \end{aligned}$$

Model evaluation: This model is based on transportation of different collected garbage and their total demand between all steps from k = 1 to k = n. This figure shows material and their data (demand) movement pathway. First step, k = nth includes accumulators and sends garbage to meet all demands. So there is no calculation in this step because it's the first step. This model talks about collected raw garbage transporting from k = nth to k = n-1, which is the separation and repulse of adverse garbage step, we call this model RRLS (Recycle Reverse Logistics System). This model attempts to evaluate garbage-recycle system and optimize total cost.

To simplify the formulation of suggested model, consider following hypotheses:

- 1-Initial inventories and maximum capacity for each kinds of collected garbage in reverse logistics system, should be considered.
- 2-Demand for each garbage and final product in all steps is clear. Practically, demands can be measured based on inputs in each steps of recycle.
- 3-Initial distribution cost is low, so entering cost of collection is considered in this model.
- 4-None of garbage is missed in reverse supply chain, it means that all entered garbage is recycled to another product.
- 5-Demand for recycled products is enough so product is piled in stock.
- 6-At k = n, there is enough garbage, so the amount of garbage in k = nth equals to k = n.

We have used an analytical linear model to reduce reverse logistics cost. RRLS model includes linear objective function (equation 1) with some limitations (equation 2-7). These limitations show applied conditions of our model in searching practical solution for decision making variables.

Mathematical formulation of suggested model is discussed as following. We can see variables in Table 1. Aim of this model is decreasing total costs of reverse logistics in a period for all steps between k = 1 and k = (n-1) (separation step).

Total cost of reverse logistics includes:

- Total collection cost between initial collecting and before separation (n = 1 to k = (n-1)).
- Total separation cost in k = (n-1)
- Total separation cost between other supplier step to final step (recycle step)
- Total inventory costs in all steps

- Total recycle cost

Table 1. Variables

Variable	Meaning
K	Shows level in reverse cycle
i	Raw garbage movement between cycles
n	Levels or cycles in reverse cycle
p	Initial collected garbage in k = nth
P'	Amount of garbage exchanging in cycle after separation step
(p-p')	Kinds which should be repulsed after separation
Q _{ik}	Amount of ith raw garbage which is transporting from (k+1) th to kth
d _{ik}	Demand for ith raw garbage from kth to (k-1) th
Q _{i0}	Amount of ith recycled garbage which is transporting from recycle unit to market (oth)
Q _{i1}	Entering amount of ith raw garbage which is transporting from second level to recycle unit
Q _{i2}	Entering amount of ith raw garbage transporting from third to second level
Q _{i3}	Entering amount of ith raw garbage transporting from fourth to third level
Q _{i(n-1)}	Entering amount of ith raw garbage transporting from nth to (n-1) level
d _{i1}	Demand for ith final product from recycle unit to market
d _{i2}	Demand for ith garbage from second level to garbage unit
d _{i3}	Demand for ith garbage from third to second level
d _{i4}	Demand for ith garbage from fourth to third level
d _{i(n-1)}	Demand for ith garbage from k = (n-1) to k = (n-2)
T _(n-1)	Total transportation cost from all p form collected raw garbage before separation and transportation from nth to n-1 th level
l _k	Total carrying distance of raw garbage between kth or k = 1 th level
S _i	Separation cost of each units of required ith raw garbage in (n-1)th level
D	Cost of repulsing in each unit of harmful garbage (p-p') and repulsed p form collected garbage
t _{ik}	Cost of carrying in each unit of recycled ith garbage after repulsing and entering from (k-1) to ith level

L _(n-1)	Total distance between nth to n-1 level
h _{ik}	Inventory carrying costs in each unit of ith raw garbage which is collected in kth level
b _{ik(0)}	Initial inventory in t = 0 for ith raw garbage which is collected in kth level
Q _{i(k-1)}	Amount of ith input raw garbage transported from kth to k-1 th level
C _{mi}	Recycle cost of each unit from ith form in recycle unit (k = 1)
B _{ik}	Storage capacity for ith form in kth level
B _{K,max}	Minimum/maximum storage capacity in kth level according to all inventories
W	Part of adverse garbage among collected garbage before separation

So objective function is:

$$T_{(n-1)} \times l_{(n-1)} \times \sum_{i=1}^p Q_{i(n-1)} + \sum_{i=1}^{p'} S_i \times Q_{i(n-1)} + D \times \left[\sum_{i=1}^p Q_{i(n-1)} - \sum_{i=1}^{p'} S_i Q_{i(n-1)} \right] + \sum_{k=1}^{n-2} \sum_{i=1}^{p'} (t_{ik} \times l_k \times Q_{ik}) + \sum_{k=1}^{n-1} \sum_{i=1}^{p'} h_{ik} \times \{b_{ik}(0) + Q_{ik} - Q_{i(k-1)}\} + \sum_{i=1}^{p'} C_{mi} Q_{i0} \tag{1}$$

Where Q_{ik} or decision variable is determined by means of linear analytical model in objective function. Conditions of this function are

$$Q_{ik} + b_{ik}(0) \geq d_{ik} \quad \forall i = 1, 2, \dots, p' \text{ and } k = 1, 2, \dots, (n-1) \tag{2}$$

$$b_{ik}(0) + Q_{ik} - Q_{i(k-1)} \leq B_{ik} \quad \forall i = 1, 2, \dots, p' \text{ and } k = 1, 2, \dots, (n-1) \tag{3}$$

$$\sum_{i=1}^{p'} B_{ki} \leq B_{k,max} \quad \forall k = 1, 2, \dots, (n-1) \tag{4}$$

$$\sum_{i=p'+1}^p Q_{i(n-1)} \leq W \times \sum_{i=1}^p Q_{i(n-1)} \tag{5}$$

$$Q_{i0} \geq d_{i1} \quad \forall i = 1, 2, \dots, p' \tag{6}$$

$$Q_{ik} \geq 0 \quad \forall i = 1, 2, \dots, p', \dots, p' \tag{7}$$

$$k = 1, 2, \dots (n - 1)$$

Second equation shows the lower limit of collected raw garbage and initial inventories, in this equation these conditions reduce total costs of recycle logistics chain. So it can be considered a limitation to optimize all variables which are associated with raw garbage entered in each step.

Third equation shows the limitation relates to separation storage, it means that all storage capacity for all raw garbage in each step should be considered. Total storage capacity limitation as has been shown in equation 4, assure us that safety of this RRLS is satisfying.

Equation 5 is for adverse garbage entering before separation. So it can be treated as limitation for amount of garbage repulse.

We hypothesized that a part of adverse garbage is not more than W% of total collected garbage. According to limitation discussed above, equation 6 shows that demand for all products in recycle unit is satisfying, equation 7 calculates decision variables. All calculations are in non-negative domain.

Sometimes, cost of each recycle unit is more than the other recycle unit, it is due to increased transportation/separation cost or other factors relate to cost. Therefore this model helps recycle industrialists to choose an alternative among optimum reverse supply chain costs. This replacement should be done along with maximization of reverse supply chain profit and minimization of each unit cost. After this decision, all parts will be aware about the amount of materials should be transported inside the centers, this can help them to program their inventories and use their capacities efficiently. According to data collected from above model, in all conditions, industrialists and reverse supply chain workers can compare their profits and costs to final production by common sources. This differential comparison can show the future of their business.

We test this model for a 4-step reverse logistics system in recycle industry. For example, we select paper as dry garbage. Therefore, we have three steps, $i = 1, 2, 3$, which are raw paper garbage between supplier X and repulse.

In repulse step, in order to remove adverse garbage, separation process will be done. In this situation we have two forms of I, $I = 1$ and $I = 2$, while $I = 3$ is the adverse garbage that should be repulsed.

These interested raw garbage will be entered to other inventory. It means that, supplier Y is located before recycle unit. Recycle unit, recycles garbage and sends recycled products immediately to market.

Following figure shows the steps.

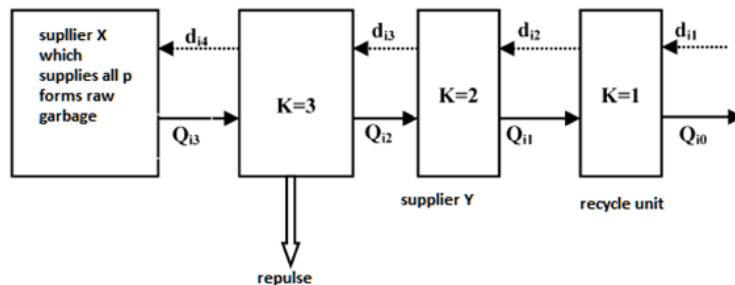

Figure 2. Four step reverse logistics system for garbage

Here we want to measure total cost of system.

Total cost of system includes recycle unit, supplier X and repulse step costs, we introduce equation 8:

Total cost = ([repulse cost in repulse step (DC3) + separation cost in repulse step (SC3) + carrying cost in repulse step of adverse garbage (CC3) + cost of collecting from supplier X to repulse unit (IC3)] + [cost of carrying from repulse step to supplier Y (CC2) + carrying cost from supplier Y (IC2)] + [carrying cost from supplier Y to

recycle unit (CC1) + carrying cost in recycle unit (IC1) + recycle cost in recycle unit (RC21)]).

So we have:

$$CC_3 = T_3 \times I_3 \times \sum_{i=1}^3 Q_{i3} \tag{9}$$

$$IC_3 = \sum_{i=1}^2 h_{i3} \times \{b_{i3}(0) + Q_{i3} - Q_{i2}\} \tag{10}$$

$$-SC_3 = \sum_{i=1}^2 S_i \times Q_{i3} \tag{11}$$

$$-DC_3 = D \times \{\sum_{i=1}^3 Q_{i3} - \sum_{i=1}^2 Q_{i3}\} \tag{12}$$

$$-CC_2 = \sum_{i=1}^2 T_{i2} \times I_2 \times Q_{i3} \tag{13}$$

$$-IC_2 = \sum_{i=1}^2 h_{i2} \times \{b_{i2}(0) + Q_{i2} - Q_{i1}\} \tag{14}$$

$$-CC_1 = \sum_{i=1}^2 t_{i1} \times l_1 \times Q_{i1} \tag{15}$$

$$-IC_1 = \sum_{i=1}^2 h_{i1} \times \{b_{i1}(0) + Q_{i1} - Q_{i0}\} \tag{16}$$

$$-RC_1 = \sum_{i=1}^2 C_{mi} \times Q_{i0} \tag{17}$$

According to above costs in reverse logistics of recycle garbage and our purpose which is reduction of costs, and maximization of profit, analytical linear objective function is:

$$\begin{aligned} & [T_3 \times I_3 \times \sum_{i=1}^3 Q_{i3} + \sum_{i=1}^2 S_i \times Q_{i3} + \sum_{i=1}^2 h_{i3} \times \{b_{i3}(0) + Q_{i3} - Q_{i2}\}] + D \times \left[\sum_{i=1}^3 Q_{i3} - \sum_{i=1}^2 Q_{i3} \right] \\ & + \left[\sum_{i=1}^2 t_{i2} \times I_2 \times Q_{i2} + \sum_{i=1}^2 h_{i2} \times \{b_{i2}(0) + Q_{i2} - Q_{i1}\} \right] \\ & + \left[\sum_{i=1}^2 t_{i1} \times l_1 \times Q_{i1} + \sum_{i=1}^2 C_{mi} \times Q_{i0} + \sum_{i=1}^2 h_{i1} \times \{b_{i1}(0) + Q_{i1} - Q_{i0}\} \right] \end{aligned} \tag{18}$$

Where:

$$-Q_{ik} + b_{ik}(0) \geq d_{ik} \quad \forall i = 1,2 \quad \text{and} \quad k = 1,2,3 \tag{19}$$

$$-b_{ik}(0) + Q_{ik} - Q_{i(k-1)} \leq B_{ik} \quad \forall i = 1,2 \quad \text{and} \quad k = 1,2,3 \tag{20}$$

$$-\sum_{i=1}^2 B_{ik} \leq B_{k,max} \quad \forall k = 1,2,3 \tag{21}$$

$$-Q_{33} \leq w \times \sum_{i=1}^3 Q_{i3} \tag{22}$$

$$-Q_{i0} \geq d_{i1} \quad \forall i = 1,2 \tag{23}$$

$$-Q_{ik} \geq 0 \quad \forall i = 1,2, \quad k = 1,2,3$$

It should be mentioned that repulse unit has to accept goods that contain at least 25% of adverse garbage, by doing so, cost will be compensated. Repulse cost of one ton garbage is 9800 toomans. Carrying cost to repulse site for one ton per 1 km is 150 tomans. Another parameters are constant. These constants calculated in above equation (18-24) can be seen in Table 2.

We calculated optimum amount of entered garbage to three step recycle unit (recycle supplier X, burying units) by Lindo software, these are shown in Table 3. Therefore, recycle cost in our reverse logistics system is 111922552 toomans.

Table 2. Calculated parameters in calculation model

Parameter	Symbol	Recycle unit(k = 1)		Supplier Y step(k = 2)		Repulse step(k = 3)	
Carrying distance(km)	lkm	800		1000		700	
Maximum capacity of storage garbage	Bk, max (ton)	600		750		950	
	Variety	i = 1	i = 2	i = 1	i = 2	i = 1	i = 2
carrying cost (tooman/ton)	Hik (R/ton)	5600	11200	8400	15400	9800	16800
Transporting cost of each unit of recycle garbage (tooman/ton)	Tik (0) (ton)	150	150	150	150	-	-
Initial inventory	Bik (0) (ton)	150	100	220	200	250	230
Storage capacity	Bik (ton)	155	120	235	236	260	280
Separation cost of each raw garbage unit (tooman/ton)	Si (Rs/ton)	-	-	-	-	4200	5600
Separation cost of each garbage unit at recycle unit (tooman/ton)	Cm (Rs/ton)	8400	12320	-	-	-	-
Demand for final product	Dik (ton)	200	175	250	265	325	450

Table 3. Optimum inputs related to considered costs in ton

Q10	Q20	Q11	Q21	Q12	Q22	Q13	Q23	Q33
<i>200</i>	<i>175</i>	<i>50</i>	<i>134</i>	<i>65</i>	<i>170</i>	<i>75</i>	<i>220</i>	<i>98.34</i>

Q_{ik}	Amount of ith raw garbage which is transporting from (k+1) th to kth
d_{ik}	Demand for ith raw garbage from kth to (k-1)th
Q_{i0}	Amount of ith recycled garbage which is transporting from recycle unit to market (oth)
Q_{i1}	Entering amount of ith raw garbage which is transporting from second level to recycle unit
Q_{i2}	Entering amount of ith raw garbage transporting from third to second level
Q_{i2}	Entering amount of ith raw garbage transporting from third to second level
Q_{i3}	Entering amount of ith raw garbage transporting from fourth to third level
$Q_{i(n-1)}$	Entering amount of ith raw garbage transporting from nth to (n-1) level

3. Conclusions

In this research, an optimization model for costs or a cost maximization model for garbage recycle reverse logistics has been developed. We called this model RRLS. We proposed a linear analytical model which reduces total cost of reverse logistics, this system is a kind of multi-variable system with some limitations. We considered several internal and external factors influencing on system. Internal factors are: carrying cost in each unit, initial inventories capacity, construction cost of each unit. External factors are demand, distance, transport cost of units between levels and cycles. This model helps organizations to use appropriate strategy.

Recycle industrialists can use this model to determine required capacity for outputs or required efficiency. Carrying cost is the crucial factor to choose the site of recycle factory. This model (reverse logistics system) results in cost reduction and helps organization to determine the location of their inventory, therefore total cost of supply chain can be reduced.

This research is a kind of model to reduce cost in a multi-variable system which increases profits by decreasing costs. We have proposed a linear analytical function by recognizing critical activities and requirements of each cyclic process in reverse logistics.

Suggested model is better than other models, because this model considers environmental problems by means of a systematic management strategy.

A supply chain or reverse logistics manager of recycle garbage factory can use this model to calculate the amount of collected garbage demand for each unit in supply chain in responding to garbage demand for different kinds of recycled products. So, total cost of reverse logistics can be reduced.

Managers can use sensitivity analysis to determine the influence of changing in initial inventory level $\{(0)bik\}$, inventory capacity (bik) , demand (dik) .

Suggested model in this research can help organizations to recognize whether being in this industry. Organizations can do it by comparison recycling costs with common sources. This can help organizations to use appropriate strategy in constructing products. Many units will be established after comparing different scenario costs. This model can help inventory manager to consider future works for purchasing materials. In order to understand the significance of reverse logistics in reducing cost prices of products, analyses conducted in USA can be mentioned. These analyses show that about 4% of logistics costs in each company is paid for reverse logistics, this percentage is high in companies or industries which their products have low quality (Low, 2007).

It should be mentioned that reverse logistics depends on industry nature; but its costs are so high. Generally reverse logistics is very important in industries which their product costs of recessives are high. Analyses show that 50% of products should be duplicated or reformed during construction process. These total recessives result in significant costs. By knowing that, costs of a recessive can be more than 2-3 times more than its external transportation cost, necessity to consider reverse logistics in industries becomes obvious for us (Altıparmak et al., 2009).

4. Suggestions

It is recommended to conduct some researches on cost optimization model, in this model, effects of governmental laws on recycle industry should be considered.

References

- Tabriz, A. A., Roghanian, E., & Hossein, N. M. (1390). *Design and optimization of reverse logistics network using genetic algorithm*. Management: Industrial management background: Summer 1390-No. 90-2.61.
- Noori, I., & Jamshid, N. A. S. (1388). A mathematical programming model for reconstruction system in reverse logistics environment. *Rooyesh Journal*, (118), 50-46.
- Altiparmak, F., Gen, M., Lin, L., & Karaoglan, I. (2009). A steady-state genetic algorithm for multi-product supply chain network design. *Computers & Industrial Engineering*, 56, 521-537. <http://dx.doi.org/10.1016/j.cie.2007.05.012>
- Cruz-Rivera, R., & Ertel, J. (2009). Reverse logistics network design for the collection of End-of-Life Vehicles in Mexico. *European Journal of Operational Research*, 196, 930-939. <http://dx.doi.org/10.1016/j.ejor.2008.04.041>
- El-Sayed, M., Afia N., & El-Kharbotly, A. (2010). A stochastic model for forward-reverse logistics network design under risk. *Computers and Industrial Engineering*, 58(3). <http://dx.doi.org/10.1016/j.cie.2008.09.040>
- Fleischmann, M., Beullens, P., Bloemhof-Ruwaard, J. M., & Wassenhove, L. (2001). The impact of product recovery on logistics network design. *Production and Operations Management*, 10. <http://dx.doi.org/10.1111/j.1937-5956.2001.tb00076.x>
- Kim, K., Song, I., Kim, J., & Jeong, B. (2006). Supply planning model for remanufacturing system in reverse logistics environment. *Computers & Industrial Engineering*, 51(2), 279-287. <http://dx.doi.org/10.1016/j.cie.2006.02.008>
- Lee, J., Gen, M., & Rhee, K. (2009). Network model and optimization of reverse logistics by hybrid genetic algorithm. *Computers & Industrial Engineering*, 56, 951-946. <http://dx.doi.org/10.1016/j.cie.2008.09.021>
- Lee, D., & Dong, M., (2008). A heuristic approach to logistics network design for end-of lease computer products recovery. *Transportation Research-Part E*, 44. <http://dx.doi.org/10.1016/j.tre.2006.11.003>
- Lu, Z., & Bostel, N. (2007). A facility location model for logistics systems including reverse flows: The case of remanufacturing activities. *Computers & Operations Research*, 34, 299-323. <http://dx.doi.org/10.1016/j.cor.2005.03.002>
- Min, H., Ko, H. J., & Park, B. I. (2005). A lagrangian relaxation heuristic for solving the multi-echelon, multi-commodity, closed-loop supply chain network design problem. *International Journal of Logistics Systems and Management*, 1(4), 382-404. <http://dx.doi.org/10.1504/IJLSM.2005.006292>

Copyrights

Copyright for this article is retained by the author(s), with first publication rights granted to the journal.

This is an open-access article distributed under the terms and conditions of the Creative Commons Attribution license (<http://creativecommons.org/licenses/by/3.0/>).