

# Northumbria Research Link

Citation: Abderezzak, Belkallouche, Busawon, Krishna and Binns, Richard (2017) Flows consumption assessment study for fuel cell vehicles: Towards a popularization of FCVs technology. *International Journal of Hydrogen Energy*, 42 (17). pp. 12905-12911. ISSN 0360-3199

Published by: Elsevier

URL: <http://dx.doi.org/10.1016/j.ijhydene.2016.12.152>  
<<http://dx.doi.org/10.1016/j.ijhydene.2016.12.152>>

This version was downloaded from Northumbria Research Link:  
<http://nrl.northumbria.ac.uk/29521/>

Northumbria University has developed Northumbria Research Link (NRL) to enable users to access the University's research output. Copyright © and moral rights for items on NRL are retained by the individual author(s) and/or other copyright owners. Single copies of full items can be reproduced, displayed or performed, and given to third parties in any format or medium for personal research or study, educational, or not-for-profit purposes without prior permission or charge, provided the authors, title and full bibliographic details are given, as well as a hyperlink and/or URL to the original metadata page. The content must not be changed in any way. Full items must not be sold commercially in any format or medium without formal permission of the copyright holder. The full policy is available online: <http://nrl.northumbria.ac.uk/policies.html>

This document may differ from the final, published version of the research and has been made available online in accordance with publisher policies. To read and/or cite from the published version of the research, please visit the publisher's website (a subscription may be required.)

[www.northumbria.ac.uk/nrl](http://www.northumbria.ac.uk/nrl)





ELSEVIER

Available online at [www.sciencedirect.com](http://www.sciencedirect.com)

ScienceDirect

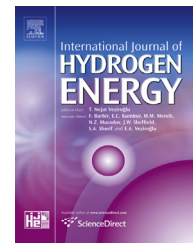
journal homepage: [www.elsevier.com/locate/ijhydene](http://www.elsevier.com/locate/ijhydene)

# Flows consumption assessment study for fuel cell vehicles: Towards a popularization of FGVs technology

B. Abderezzak <sup>a,\*</sup>, K. Busawon <sup>b</sup>, R. Binns <sup>b</sup>

<sup>a</sup> Faculty of Science and Technology, University of Khemis Miliana, Road of Theniet El Had, 44225, Khemis Miliana, Algeria

<sup>b</sup> Faculty of Engineering and Environment, Northumbria University, Ellison Building, NE1 8ST Newcastle upon Tyne, United Kingdom

## ARTICLE INFO

### Article history:

Received 12 July 2016

Received in revised form

19 December 2016

Accepted 30 December 2016

Available online xxx

### Keywords:

Fuel cell vehicles

Energy management

Hydrogen consumption

Car autonomy

Road profile

## ABSTRACT

Climate change can be caused by a major part from the high fossil fuel usage and consumption in transportation field. It contributes to the increase of pollutant emissions, which lead to serious problems on human health in addition to the environmental degradation phenomena. Hydrogen fuel cell vehicles (FCVs) are expected to have a significant impact in meeting both energy security and environmental concerns globally. Starting for the premise that public acceptance and attitudes studies were generally positive towards hydrogen and fuel cells vehicles, even if the public knows few things about this technology; authors then got the idea to present a simplified scientific work dealing with the description of the energy management and flows calculations on board FCVs. This work aims not only to the popularization of this technology but also to outreach people about its sustainable character. A variable driving profile is adopted with a total distance of 1 km with duration of 60 s. The total hydrogen amount consumed is 1,34 g km<sup>-1</sup>. Under pressure, only 5 kg of hydrogen give optimal autonomy of 700 km, which is really competitive to the conventional gasoline cars. A nice advantage is yet observed and its concerns the environmental profits.

Crown Copyright © 2017 Published by Elsevier Ltd on behalf of Hydrogen Energy Publications LLC. All rights reserved.

## Introduction

Fossil fuels used in transportation for our daily life are not only going to be depleted, but also they are highly polluting. This pollution has obviously very bad impacts on human health. Against this serious problem, some industrial

countries are encouraging electrical vehicles under the slogan of zero emission cars. Unfortunately, these Electrical cars present some technological drawbacks which are summed up on the long charging time and the autonomy.

A comprehensive and sustainable solution of the issues of climate change, urban air pollution and oil dependence, can be found by using hydrogen energy and fuel cells technology

\* Corresponding author.

E-mail addresses: [b.abderezzak@univ-dbk.m.dz](mailto:b.abderezzak@univ-dbk.m.dz) (B. Abderezzak), [krishna.busawon@northumbria.ac.uk](mailto:krishna.busawon@northumbria.ac.uk) (K. Busawon), [richard.binns@northumbria.ac.uk](mailto:richard.binns@northumbria.ac.uk) (R. Binns).

<http://dx.doi.org/10.1016/j.ijhydene.2016.12.152>

0360-3199/Crown Copyright © 2017 Published by Elsevier Ltd on behalf of Hydrogen Energy Publications LLC. All rights reserved.

**Nomenclature**

$C_p$	Heat capacity, $J\ kg^{-1}\ K^{-1}$
$C_r$	Car rolling coefficient
$C_x$	Air penetration coefficient
$d$	Difference (dv/dt), $m^2\ s^{-1}$
$g$	Gravity, $m\ s^{-2}$
$M_v$	Car Weight, kg
$N_{cell}$	Cell number, cells
$P$	Power, W
$P_0$	Atmospheric Pressure, atm
$P_{syst}$	System Pressure, atm
$q$	Reactants and products flows, $kg\ s^{-1}$
$S$	Frontal car surface, $m^2$
$t$	Time, s
$T_e$	Temperature of air, K
$v$	Car Speed, $km\ h^{-1}$
$V_c$	Cell Voltage, V

*Greek letters*

$\alpha$	car angle with horizon
$\eta$	Efficiency
$\rho$	Density, $kg\ m^{-3}$
$\nu$	Air stoichiometric rate
$\gamma$	Air isentropic coefficient

*Superscripts and subscripts*

<i>aux</i>	auxiliaries
<i>c</i>	compressor, efficiency
<i>comp</i>	compressor
<i>m</i>	mechanical
<i>m</i>	moto compressor, efficiency
<i>net</i>	net, power
<i>t</i>	traction, efficiency

on board cars, which lead to the expression of Fuel Cell Vehicles (FCVs) or even Fuel Cell Electrical Vehicles (FCEVs). In fact, the Polymer Electrolyte Membrane Fuel Cells PEMFCs uses hydrogen to produce power, heat and water. The power is instantly produced while hydrogen feed the PEMFC [1]. Significant advantages are obtained from this relatively expensive technology. The hydrogen feeding the PEMFC can be produced using a renewable energy source; some experimental works at the laboratory scale demonstrated the possibility to produce hydrogen from water electrolysis using Solar Photovoltaic Panels [2]. This step is considered as an environment protection action.

FCVs have the highest potential efficiencies and lowest potential emissions of any vehicular power source. Current researches are dealing with the improvement of FCVs performance, durability and cost of fuel cell technology. Component degradation and durability is anticipated to be a critical issue for the practical use of fuel cells. Component development is also a key issue for the development of FCVs; Dawei et al. [3] proposed in their works an interleaved step – up/step – down converter for fuel cell vehicle applications.

An environmental analysis of the impact of FCVs is a popular topic for research, and has appeared frequently in recent literature. Fletcher et al. [4] have even discussed the energy management strategy to optimize both fuel

consumption and PEM fuel cell lifetime in a hybrid vehicle. Mebarki et al. [5] have studied a hybrid power system composed of a PEM fuel cell and a battery storage system to supply an electric vehicle.

Furthermore, vehicular fuel cell stacks are expected to have a nominal lifetime of at least 5000 h, which is equivalent to 150,000 mile at 30 mile per hour [6].

A good review was conducted by Al Amin et al. [7] on the public acceptance and attitudes for hydrogen Fuel cell vehicles. This review was very important to influence the consumer behavior towards environmental benefits.

Henceforth, it is acknowledge that public acceptance and attitudes studies were generally positive towards hydrogen and fuel cells vehicles, even if the public knows few things about this technology [8]. Starting from this premise, authors got the idea to present a simplified scientific work dealing with the technology of Fuel Cell Vehicles FCV's.

This work aims not only to the popularization of this technology but also to outreach people about its sustainable character.

The different flows (reacted, consumed and produced) are illustrated based on a variable and comprehensive driving profile achieving a distance of 1 km in one minute. This work will help young researchers and interested public to get a clear idea about the real challenge of this environment friendly technology.

This work can also be coupled with an environmental and economic analysis to obtain a realistic indication of the viability of an FCV market such as in the work of Veziroglu et al. 2011 [6].

## Fuel cell vehicle technology description and state of the art

The PEMFC is known to produce power with an efficiency of 55% for the stack. It is very suitable for vehicles as it can offer efficient energy conversion in a compact and robust package. Its significant features in generating reliable and efficient electrical power at steady state condition, with higher power density and lower operation temperature, are considered as the prime candidate for vehicular applications [9].

The average fuel efficiency of new cars is between 20 and 30 mpg (miles per gallon), which is equivalent to a range starting from 8.5 to 12.75  $km\ l^{-1}$ , (kilometer per liter).

Current vehicles hold 10 to 16 gallons of gasoline, or 30–45 L of space. Since hydrogen has twice the efficiency of gasoline vehicles, they would store between 5 and 8 kg of hydrogen, which is equivalent to between 200 and 400 L, which is a sizable reduction in the space needed for fuel. Liquid hydrogen tanks are also less bulky and can also be used in the vehicle to feed the PEMFC Stack, but they must be stored at extremely low temperatures [10].

The four major subsystems of any hydrogen fuel cell system are the fuel cell stack, air supply, hydrogen supply, and water and thermal management. A good illustration of this system is presented in Fig. 1.

However, the net power delivered by a PEMFC stack can be limited to 65%, while air circuit need 25%, humidification circuit need 5%, the cooling circuit need 3% and 2% of the total

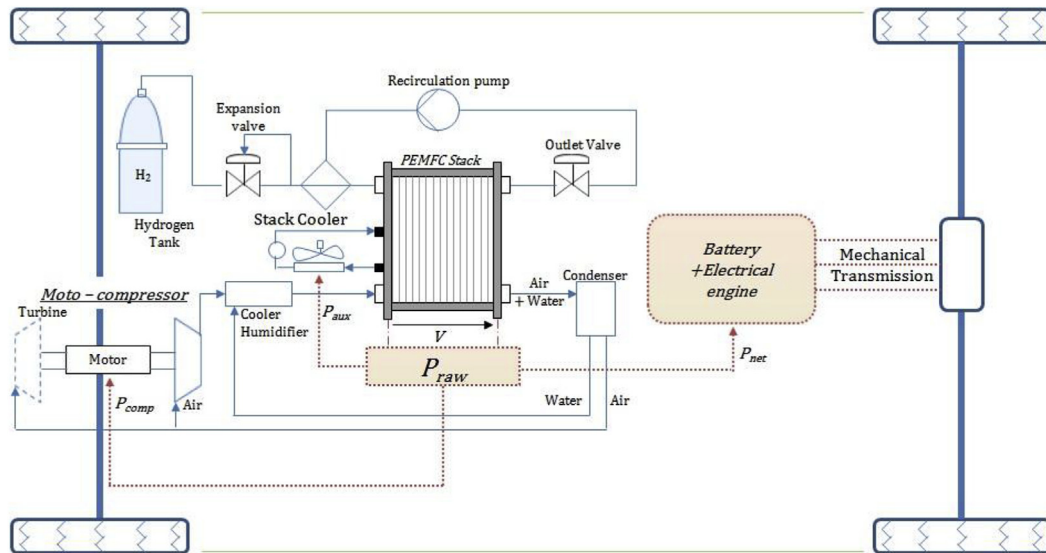

Fig. 1 – Fuel cell vehicles technology demonstration.

delivered power dedicated to the hydrogen circuit. Fig. 2 summarizes these data.

Hydrogen is produced and stored in the refueling station. An approximate refueling time of three minutes is needed. Hydrogen then is stored in the compressed tank on board FCVs. It should be noted that there is an influence of the initial tank temperature on the evolution of the internal gas temperature during the refueling of on-board hydrogen tanks [11].

In literature, we can also find a hazards assessment and associated risks of a hydrogen leakage accident in the work of Choi et al. [12].

Many other research efforts strengthen and ensure the hydrogen and fuel cells field like the study of dynamic modeling of a cell system on bicycle in the work of Kheirandish et al. 2016 [13].

Some new concept of extended range Electric Vehicle (EREV) can be revisited in the literature following the work of Fernandez et al. [14].

In the work of Benyahia et al. [15], a good modeling approach of the FCVs using an interleaving technique is presented in order to increase the accurate modeling of the power source, the power converter and the load to evaluate the full system performances since the simulation step. In

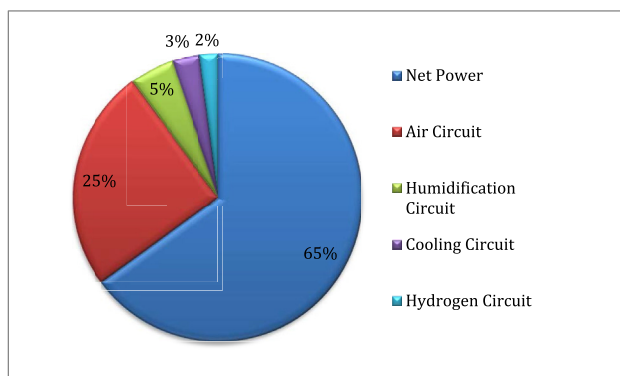

Fig. 2 – Energy consumption rates on board FCVs.

this study, a super capacitor is associated as an auxiliary device with the fuel cell to ensure the power reversibility in the drive train. The fuel cell and the supercapacitor are connected to the dc bus throughout an interleaved boost converter and an interleaved buck-boost converter respectively. The control of the proposed system is designed using the discrete proportional integral (PI) controllers and the digital width pulse modulation (DPWM). The proposed controller improves the dynamic performance of the converters by achieving a robust bus voltage and inputs currents against load disturbances.

## Energy and flows calculations

In this part, authors tried to study the energy and flows changes for a given driving profile, presented in Fig. 3, running a distance of 1 km in 60 s. All data related to the PEMFC stack and other conditions are presented in Table 1.

The power delivered by the fuel cell is used for both electric motor for vehicle traction and for auxiliaries (Air compressor, water pump and air fan for stack cooling).

The vehicle mechanical power based on the variation of the car speed and friction (air and soil), is calculated thanks to Equation (1); all the following equations are taken from Ref. [16]:

$$P_m = v \left( M_v \frac{dv}{dt} + \frac{1}{2} \rho_{air} v^2 S C_x + M_v g \sin \alpha + M_v g C_r \cos \alpha \right) \quad (1)$$

The net power useful for the vehicle traction is then calculated with consideration to the traction – electric motor efficiency as presented in Equation (2):

$$P_{net} = \frac{P_m}{\eta_t} \quad (2)$$

The embedded hydrogen tank is usually under the pressure of 300 atm, an expansion valve is used to get an appropriate pressure of 3 atm, at the entrance of the PEMFC stack.

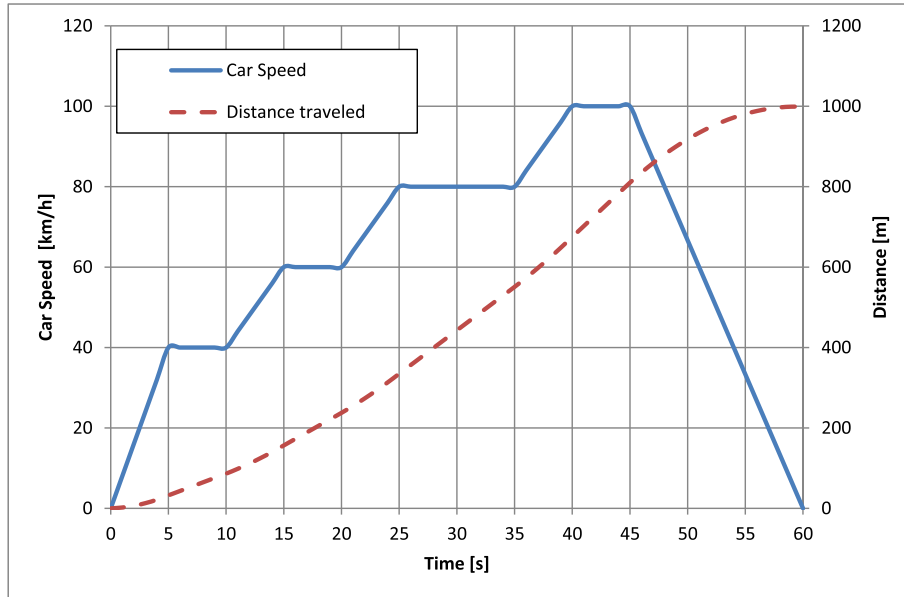

Fig. 3 – The adopted driving profile and the traveled distance.

Table 1 – The data input of the PEMC and vehicle.

Parameters	Units	Values
$T_e$	K	293,15
$\alpha$	–	0
$\eta_t - \eta_c - \eta_m$	–	0,9 - 0,7 - 0,9
$\gamma$	–	1,4
$\nu$	–	2
$P_{syst}/P_0$	atm	3/1
$C_p$	J kg <sup>-1</sup> K <sup>-1</sup>	1004
$C_r/C_x$	–	0,01/0,3
$M_v$	kg	1200
$S$	m <sup>2</sup>	2,5
$g$	m s <sup>-2</sup>	9,81
$P_{stack}/V_c/N_{cell}$	kW/V/cells	50/0,69/900

For the air supply system, we need an air compressor to achieve the working pressure and to recover the pressure drop all over the stack. The compressor electrical power depends on the air flow needed by the stack; they are summarized in Equations (3) and (4).

$$P_{comp} = \frac{q_{air} T_e C_p}{\eta_c \eta_m} \left( \left( \frac{P_{syst}}{P_0} \right)^{\frac{\gamma-1}{\gamma}} - 1 \right) \tag{3}$$

And for the air flow expressed in [kg s<sup>-1</sup>], we have:

$$q_{air} = 3,57 \times 10^{-7} \nu \frac{P_{raw}}{V_c} \tag{4}$$

We can then calculate the amount of residual air called “dry outlet air” by removing the reacted oxygen as well as described in Equation (5):

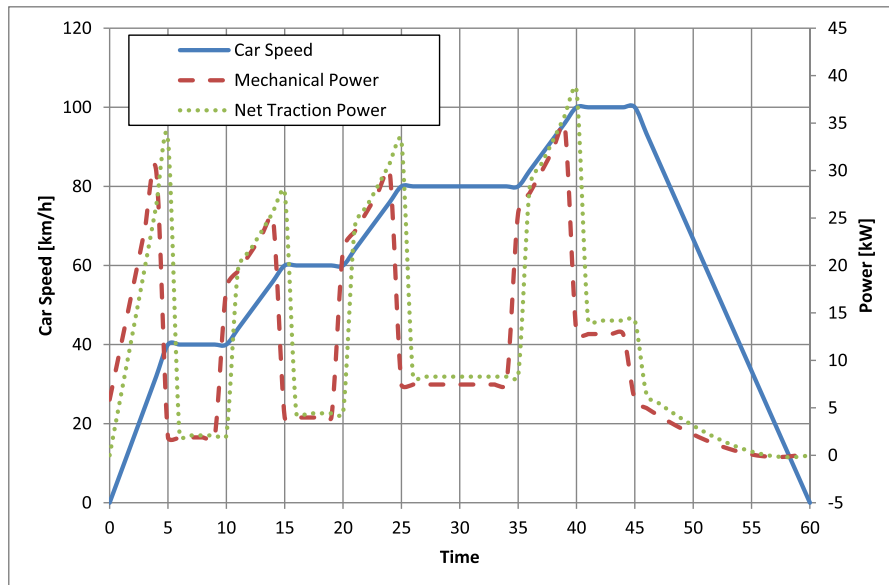

Fig. 4 – Relationship between car speed, mechanical power and net traction power.

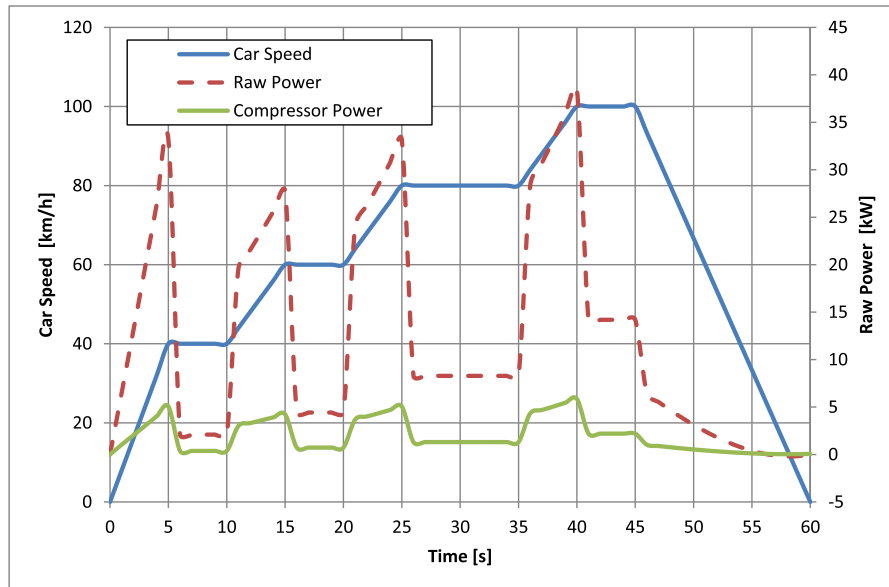

Fig. 5 – Relationship between car speed, raw power and compressor power.

$$q_{air,dry,out} = ((3,57 \times 10^{-7}v) - 8,29 \times 10^{-8}) \frac{P_{raw}}{V_c} \quad (5)$$

And for the reacted oxygen:

$$q_{O_2} = 8,29 \times 10^{-8} \frac{P_{raw}}{V_c} \quad (6)$$

Simplified equations found in Ref. [13] permit to calculate the amount of reacted hydrogen and the amount of the water produced, they are illustrated respectively in Equations (7) and (8):

$$q_{H_2} = 1,05 \times 10^{-8} \frac{P_{raw}}{V_c} \quad (7)$$

And for water:

$$q_{H_2O} = 9,34 \times 10^{-8} \frac{P_{raw}}{V_c} \quad (8)$$

The raw power is simply the sum of the net power delivered for traction, the compressor power and the auxiliaries power estimated in general cases at 400 W. It is expressed as in Equation (9):

$$P_{raw} = P_{net} + P_{comp} + P_{aux} \quad (9)$$

## Results and discussion

The first results show that there is a close relationship between the acceleration presented previously in Fig. 3, and the

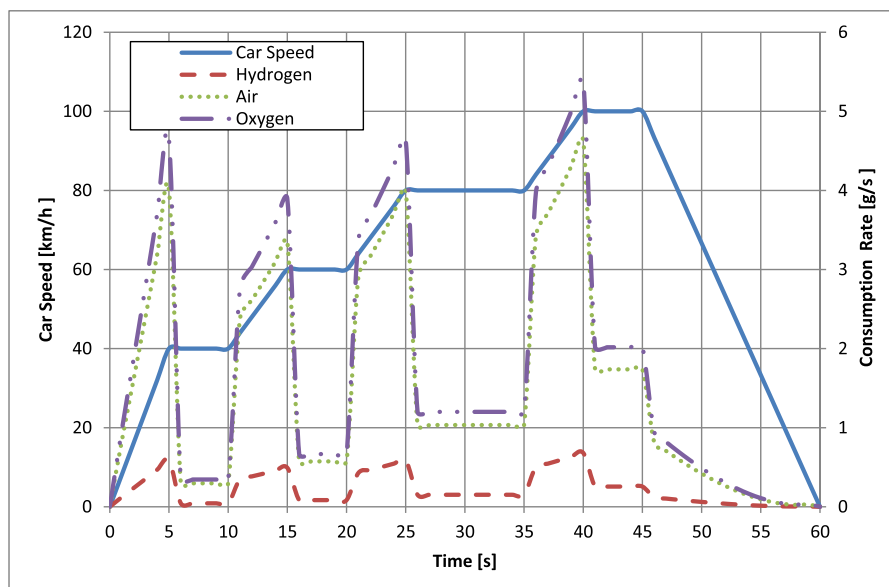

Fig. 6 – Reactant consumption rates during the driving profile.



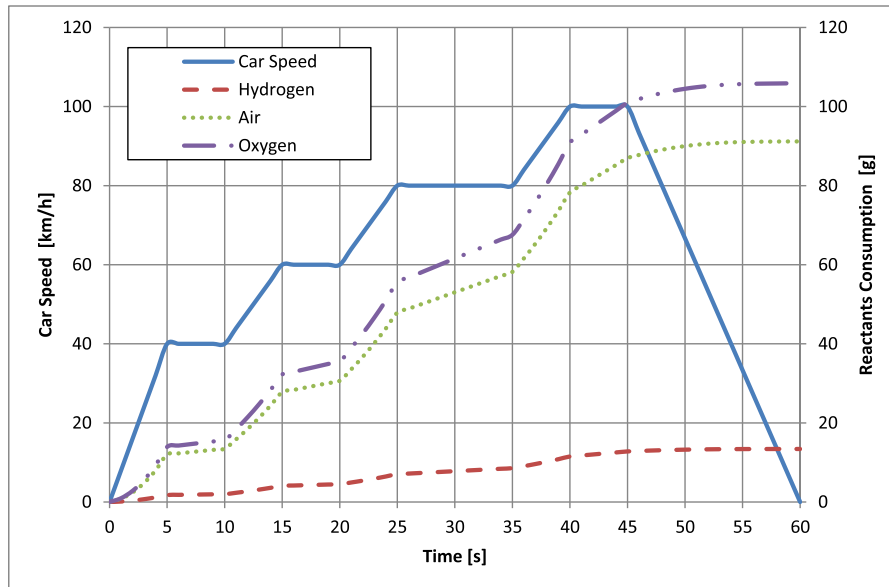

Fig. 7 – Reactant consumption amounts for a distance of 1 km.

different kind of powers cited before. From Fig. 4, we can observe that the traction power is following the car speed profile. A greater value of about 39 kW is registered at time 40 s at a speed of 100 km h<sup>-1</sup>.

We can observe from Fig. 5 that the compressor maximum power is also at time 40 s, with a value of 5,8 kW which represents an average of 14,5% of the raw power.

The consumption rates of each reactant species are presented in Fig. 6. We can observe the each reactant follow the power demand. The total amounts of reactants are presented in Fig. 7.

For hydrogen, the reacted rate keep increasing for accelerations period [0–5; 10–15; 20–25; 35–40] to get the maximum value of 0,68 g s<sup>-1</sup> at time 40 s. Otherwise, at levels period [5–10; 15–20; 25–35; 40–45], a maximum value is about

0,25 g s<sup>-1</sup>. The total amount of hydrogen consumption during this driving profile of 1 km is 1,34 g.

For air, the reacted rate also keep increasing for accelerations period to get the maximum value of 4,63 g s<sup>-1</sup> at time 40 s. Otherwise, at levels period, a maximum value is about 1,73 g s<sup>-1</sup>. The total amount of air consumption during this driving profile of 1 km is 91,1 g.

For oxygen, the reacted rate also keep increasing for accelerations period to get the maximum value of 5,37 g s<sup>-1</sup> at time 40 s. Otherwise, at levels period, a maximum value is about 2,01 g s<sup>-1</sup>. The total amount of oxygen consumption during this driving profile of 1 km is 105 g.

For water, Figs. 8 and 9 represent respectively the water rate according to the car speed change, and total amount of the produced water.

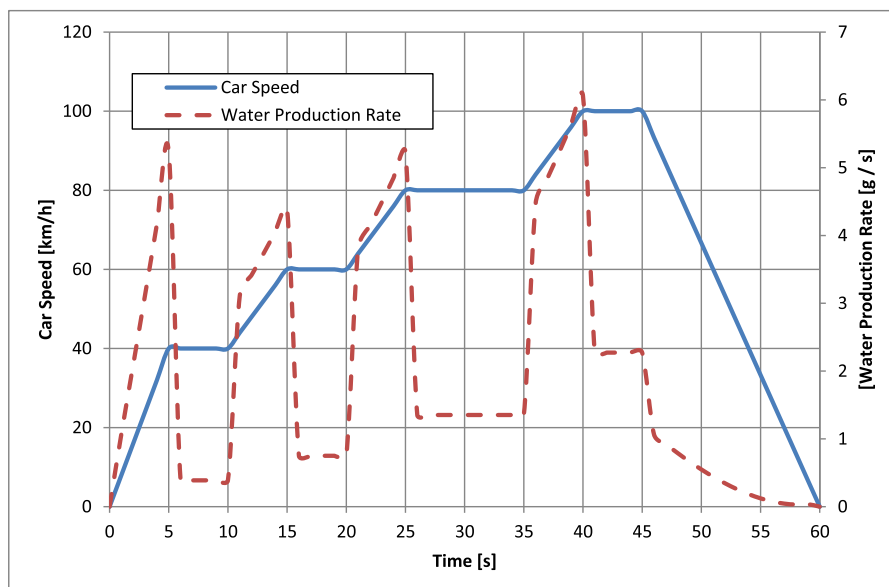

Fig. 8 – Water production rate during the driving profile.

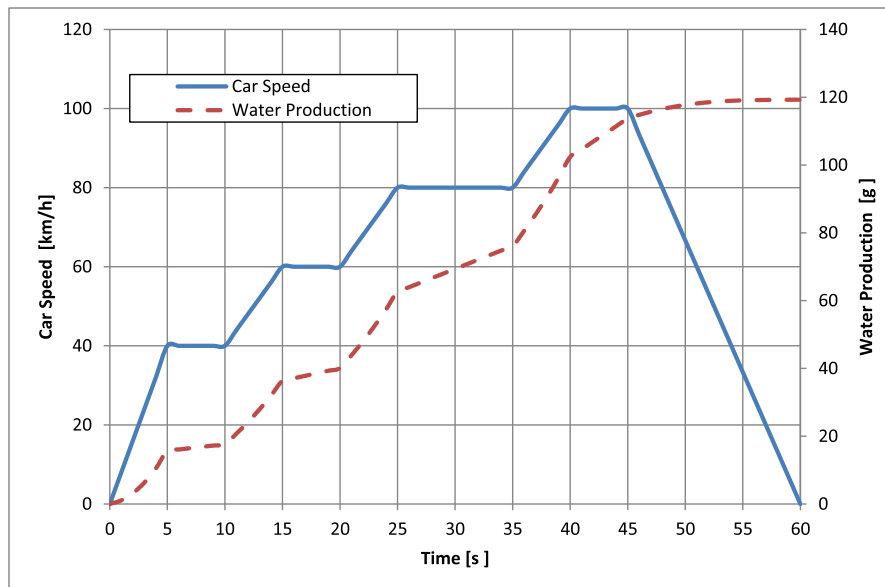

Fig. 9 – Water production amount for a distance of 1 km.

the product rate increase during accelerations period to get the maximum value of  $6,05 \text{ g s}^{-1}$  at time 40 s. Otherwise, at levels period, a maximum value is about  $2,27 \text{ g s}^{-1}$ . The total amount of water production during this driving profile of 1 km is 120 g.

## Conclusion and future works

This work is a simplified study to understand the behavior of the different flows (reactants and products) in the Fuel Cell Vehicles. A variable driving profile is adopted with a total distance of 1 km with duration of 60 s. The results can be generalized and should be used as standard theoretical values. The total hydrogen amount consumed is  $1,34 \text{ g km}^{-1}$ , and it can be considerably optimized using controllers. If we consider a hydrogen tank with the mean capacity of 5 kg under 300 atm, we can then get an optimal case of 700 km of autonomy, which is really competitive to the conventional gasoline cars. A nice advantage is yet observed and its concerns the environmental profits.

Authors are now motivated in their future works by studying the economical issues of the FCVs.

## REFERENCES

- [1] Abderezzak B, Khelidj B, Tahar Abbes M. Performances prediction study for proton exchange membrane fuel cells. *Int J Hydrogen Energy* 2014;39(27):15206–14.
- [2] Abderezzak B, Khelidj B, Tahar Abbes M. Modeling charge transfer in a PEM fuel cell using solar hydrogen. *Int J Hydrogen Energy* 2014;39(3):1593–603.
- [3] Dawei G, Zhenhua J, Jiexun L, Minggao O. An interleaved step-up/step-down converter for fuel cell vehicle applications. *Int J Hydrogen Energy* 2016;41(47):22422–32.
- [4] Fletcher T, Thring R, Watkinson M. An Energy Management Strategy to concurrently optimise fuel consumption & PEM fuel cell lifetime in a hybrid vehicle. *Int J Hydrogen Energy* 2016;41(46):21503–15.
- [5] Mebarki N, Rekioua T, Mokrani Z, Rekioua D, Bacha S. PEM fuel cell/battery storage system supplying electric vehicle. *Int J Hydrogen Energy* 2016;41(45):20993–1005.
- [6] Veziroglu A, Macario R. Fuel Cell Vehicles; State of the art with economic and environmental concerns. *Int J Hydrogen Energy* 2011;36(1):25–34.
- [7] Al –Amin A, Angelina FA, Masud MM, Nurul Azam M. People Purchase intention towards hydrogen fuel cell vehicles: an experiential enquiry in Malaysia. *Int J Hydrogen Energy* 2016;41(4):2117–27.
- [8] Hardman S, Chandan A, Shiu E, Steinberger-Wilckens R. Consumer attitudes to fuel cell vehicles post trial in the United Kingdom. *Int J Hydrogen Energy* 2016;41(15):6171–9.
- [9] Rajabzadeh M, Taghi Bathaee SM, Golkar MA. Dynamic modeling and nonlinear control of cell vehicles with different hybrid power sources. *Int J Hydrogen Energy* 2016;41(4):3185–98.
- [10] Dalvi A, Guay M. Control and real-time optimization of an automotive hybrid fuel cell power system. *Control Eng Pract* 2009;17(8):924–38.
- [11] De Miguel N, Acosta B, Baraldi D, Melideo R, Ortiz Cebolla R, Moretto P. The role of initial tank temperature on refueling of on-board hydrogen tanks. *Int J Hydrogen Energy* 2016;41(20):8606–15.
- [12] Choi J, Hur N, Kang S, Lee ED, Lee KB. A CFD simulation of hydrogen dispersion for the hydrogen leakage from a fuel cell vehicle in a underground parking garage. *Int J Hydrogen Energy* 2013;38(19):8084–91.
- [13] Kheirandish A, Motlagh F, Shafiabadi N, Dahari M. Dynamic modeling of PEM fuel cell of Power electric bicycle system. *Int J Hydrogen Energy* 2016;41(22):10228–38.
- [14] Fernandez RA, Cilleruello FB, Martinez IV. A new Approach to battery powered electric vehicles: a hydrogen fuel-cell-based range extender system. *Int J Hydrogen Energy* 2016;41(8):4808–19.
- [15] Benyahia N, Denoun H, Zaouia M, Rekioua T, Benamrouche N. Power systems simulation of fuel cell and supercapacitor based electric vehicle using an interleaving technique. *Int J Hydrogen Energy* 2015;40(45):15806–14.
- [16] Blunier B, Miraoui A. Piles à Combustible. 1st ed. Paris, France: Technosup Génie Énergétique; 2007.