

Non Isolated and Non-Inverting Cockcroft-Walton Multiplier Based Hybrid 2Nx Interleaved Boost Converter for Renewable Energy Applications

M.S. Bhaskar¹, P. Sanjeevikumar^{2*}, F. Blaabjerg³, V. Fedák⁴, M. Cernat⁵, R.M. Kulkarni¹

¹Department of Electrical & Electronics Engineering, Marathwada Institute of Technology, Aurangabad, India.

²Department of Electrical & Electronics Engineering, University of Johannesburg, Auckland Park, South Africa.

³Center for Reliable Power Electronics (CORPE), Department of Energy Technology, Aalborg University, Aalborg, Denmark.

⁴Department of Electrical Engineering & Mechatronics, Technical University of Košice, Košice, Slovak Republic.

⁵Department of Electrical Engineering, Transilvania University of Brasov, Brasov, Romania.

* Corresponding Author Email: sanjeevi_12@yahoo.co.in

Abstract—In this paper hybrid non isolated and non-inverting Cockcroft-Walton multiplier based 2Nx Interleaved Boost converter (2Nx IBC) for renewable energy applications is presented. The presented hybrid boost converter topology is derived from non-inverting Nx Multilevel Boost Converter (Nx MBC) and inverting Nx Multilevel Boost Converter (Nx MBC). In renewable energy applications, generated voltage needs to be stepped up with high conversion ratio using a DC-DC converter at voltage levels as per the application requirement. The advantages of the presented topology of interleaved converter are high voltage conversion ratio, reduce ripple, low voltage stress, non-inverting output voltage without utilizing the high duty cycle, coupled inductors and transformer. The main advantage of presented topology consists in increasing voltage gain by adding capacitor and diode into circuitry without disturbing the main circuit. Moreover, the presented topology is compared with several recent non isolated high gain DC-DC converters. The proposed topology is simulated in MATLAB/SIMULATION and obtained results verify the validity of the design and operation of converter.

Index Terms—Non isolated; Non-inverting; Interleaved boost converter; High Conversion; Renewable Energy.

I. INTRODUCTION

Most of current world energy is generated through exhaustible sources. Hence all the power electronics researchers are observing a paradigm shift towards use of renewable energy sources in power generation. Renewable sources include but are not limited to solar, wind, geothermal and tidal energies. On a comparative note, solar energy is the cleanest and the most abundant source; and is observing huge advances with constantly developing highly efficient photovoltaic cells. Nowadays, increasing amount of these renewable sources is being utilised using technologies like fuel cell stacks and solar arrays which power front-end DC/DC applications [1]-[4]. In order to connect these non-conventional energy based power generation systems, high gain DC-DC converters are utilised which step up the output voltage to sync the system with the grid or inverter.

The low voltage generated from solar array is needed to be stepped up before connecting to the end applications. Boost converters prove to be useful in these scenarios to fulfil application requirements [1]-[14]. Design constraints make it

difficult for conventional boost converters to work with high duty cycles. This problem is overcome by employing cascade boost converters, [2]. Cascading of the converters leads to non-uniform voltage stresses across switches, which reduces the efficiency of converter with increase in the stages owing to the insertion loss. This is overcome using isolated boost converters in [2]. But, when it comes to isolated converters with transformers we observe a problem of saturation of transformer along with fluctuation in output from the desired value which produces ripples in output along with making the circuit bulky. The gain can be increased in the most economically manageable way by using voltage multipliers. This concept is demonstrated in [14] by employing various non-inverting and inverting boost converter topologies supported by voltage multipliers. These multiplier boost converter topologies give comfortable solutions for achieving high conversion ratio. The proposed circuit deploys a Cockcroft-Walton voltage multiplier which proves to be a feasible solution for gain intensification.

The function-ability of the converter is highly influenced by passive elements used in the converter and also by its operating frequency. Low values of the reactive components when used with high frequency switches produce acceptable magnitude of output voltage, but have a drawback of high ripple production [2]. In order to get over with the problem of current ripple across inductor, the value of inductance is increased which in turn increases the cost and size of converter with improvement in transient response time [14]. To minimise the current ripple, interleaved structure is employed in high current applications. The interleaved structure presents basically the same converter connected in parallel to the circuit in existence. This, along with reduction in output distortion, also reduces the current rating of the components. Various recent DC-DC converters derived from boost converter (light yellow colour) and buck boost converter (light blue colour) to boost the output voltage with high conversion ratio are illustrated in Fig.1 (a)-(l) with description of the gain formulation in Table I.

This paper presents a non isolated and non-inverting Cockcroft-Walton multiplier based hybrid 2Nx interleaved boost converter for renewable energy applications (where N is number of voltage levels).

The paper is organized as follows: The circuit description and working modes of non isolated and non inverting Cockcroft-Walton multiplier based on hybrid 2Nx interleaved boost converter are provided in their section II. In the section III the presented topology is compared with recent high step up converter. MATLAB simulation results of the presented topology are provided in IV. Finally, conclusion is provided in the section V.

II. NON ISOLATED AND NON-INVERTING COCKCROFT-WALTON MULTIPLIER BASED HYBRID 2NX INTERLEAVED BOOST CONVERTER

A. Power Circuit Description

The power circuit of a non isolated and non-isolated 2Nx interleaved boost converter is depicted in the Fig2(a). Presented 2Nx Interleaved Boost Converter circuit is derived from combination of non-inverting Nx Multilevel Boost Converter (Nx MBC) and inverting Nx Multilevel Boost Converter (Nx MBC) as shown in Fig2(a).

2Nx interleaved boost converter required $4N-1$ capacitors, $4N-1$ diodes along with 2 identical inductor and 2 switches. More number of levels can be increased by adding capacitor and diode circuitry into the present topology in order to increase the voltage gain without disturbing the main circuit.



Fig.1(a) Conventional Boost Converter; (b) Switched Inductor (SI) Boost Converter[2]; (c) Single switch Quadratic Boost Converter (QBC) [2],[4] (d) Conventional Three Level Boost Converter [2],[6]; (e) Quadratic Three Level Boost Converter [5]; (f) Converters using bootstrap capacitors and boost inductors; (g) Switched Capacitor Based Boost Converter [7]; (h) Two-phase quadrupled interleaved boost converter [8]; (i) High-voltage gain two-phase interleaved boost converter using one VMC[9]; (j) Extra high voltage (HV) DC-DC converter [10]-[13]; (k) Nx Multilevel Boost Converter (MBC) [14]; (l) inverting Nx Multilevel BuckBoost Converter (MBBC) [14].

$$V_o = V_{op} + V_{op}'(1)$$

$$V_o = VC_{P1} + VC_{P'1} + VC_{P2} + VC_{P'2} + \dots + VC_{P2N-1} + VC_{P'2N-1}(2)$$

$$V_o = 2N \times VC_{P'1} = 2N \times VC_{P2} = \dots = 2N \times VC_{P2N-1} = 2N \times VC_{P'2N-1}(3)$$

TABLE I. VOLTAGE GAIN OF RECENT DC DC CONVERTERS

Converter Topology	Voltage Conversion Ratio, $D = \text{Duty Cycle}$
Conventional Boost Converter	$1/(1-D)$
Switched Inductor (SI) Boost Converter	$1+D/(1-D)$
Single switch Quadratic Boost Converter	$1/(1-D)^2$
Conventional Three Level Boost Converter	$2/(1-D)$
Quadratic Three Level Boost Converter	$1/(1-D)^2$
Converters using bootstrap capacitors and boost inductors	$3+D/1-D$
Switched Capacitor Based Boost Converter	$1+D/1-D$
Two-phase quadrupled interleaved boost converter	$4/(1-D)$
High-voltage gain two-phase interleaved boost converter using one VMC	$((VMC + 1)/1 - D)$
Extra high voltage (HV) DC-DC converter	$4/(1-D)$
Nx Multilevel Boost Converter (MBC)	$N/(1-D)$
Nx Multilevel Buck Boost Converter (MBBC)	$-N/(1-D)$

B. Operation modes:

To explain the operation modes of the present topology the 6x interleaved boost converter is analysed with assuming ideal components and the capacitors that are large enough, and the circuits operate in continuous conduction mode. The proposed converter can exercise in four modes of operations as given below:

1) Mode 1: When switch S_P and $S_{P'}$ are ON

When both the switches (S_P and $S_{P'}$) are conducting (ON) both inductors L_P and $L_{P'}$ are charged with source voltage V_{in} . The load side capacitors C_{P1} , C_{P3} and C_{P5} are discharged through the load. The potential across the capacitors make the diodes D_{P2} , D_{P4} forward biased and the load side capacitors C_{P1} and C_{P3} discharges through the path of diodes to the charge capacitors C_{P2} and C_{P4} . The potential across the capacitors $C_{P'}$, $C_{P'2}$ and $C_{P'4}$ make the diodes $D_{P'1}$, $D_{P'3}$ and $D_{P'5}$ forward biased. The capacitors $C_{P'}$, $C_{P'2}$ and $C_{P'4}$ discharges through the path of diodes to charge the capacitors $C_{P'1}$, $C_{P'3}$ and $C_{P'5}$.

Fig. 2(b) shows the equivalent circuit when both switches S_P and $S_{P'}$ are conducting (ON). In this mode of operation the diodes D_{P1} , D_{P3} , D_{P5} , D , $D_{P'2}$ and $D_{P'4}$ are reversed biased.

$$VL_P = VL_{P'} = V_{in}(4)$$

$$VC_{P2} = VC_{P1}(5)$$

$$VC_{P2} + VC_{P4} = VC_{P1} + VC_{P3}(6)$$

$$VC_{P'1} = VC_{P'}(7)$$

$$VC_{P'1} + VC_{P'3} = VC_{P'} + VC_{P'2}(8)$$

$$VC_{P'1} + VC_{P'3} + VC_{P'5} = VC_{P'} + VC_{P'2} + VC_{P'4}(9)$$

$$V_o = VC_{P1} + VC_{P3} + VC_{P5} + VC_{P'1} + VC_{P'3} + VC_{P'5}(10)$$

2) Mode 2: When switch S_P is ON and switch $S_{P'}$ is OFF

The equivalent circuit of the proposed converter when switch S_P is conducting (ON) and switch $S_{P'}$ is not conducting (OFF) is given in Fig. 2(C). The inductor L_P gets charged with source voltage V_{in} and the load side capacitors C_{P1} , C_{P3} and C_{P5} are discharged through the load. Also, the load side capacitors C_{P1} and C_{P3} discharges through the diodes D_{P2} , D_{P4} to charge the capacitors C_{P2} and C_{P4} . The capacitors $C_{P'1}$, $C_{P'3}$ and $C_{P'5}$ discharges through the path V_{in} , inductor $L_{P'}$ the diodes D , $D_{P'2}$ and $D_{P'4}$ to charge the capacitors $C_{P'}$, $C_{P'2}$ and $C_{P'4}$. In this mode the diode D_{P2} , D_{P4} , D , $D_{P'2}$ and $D_{P'4}$ are forward biased and the diodes D_{P1} , D_{P3} , D_{P5} , $D_{P'1}$, $D_{P'3}$ and $D_{P'5}$ are reversed biased.

$$VL_P = V_{in}(11)$$

$$VC_{P2} = VC_{P1}(12)$$

$$VC_{P2} + VC_{P4} = VC_{P1} + VC_{P3}(13)$$

$$VC_{P'} = V_{in} - VL_{P'}(14)$$

$$VC_{P'} + VC_{P'2} = V_{in} - VL_{P'} + VC_{P'1}(15)$$

$$VC_{P'} + VC_{P'2} + VC_{P'4} = V_{in} - VL_{P'} + VC_{P'1} + VC_{P'3}(16)$$

3) Mode 1: When S_P and $S_{P'}$ are OFF

The equivalent circuit of the proposed converter when both switch S_P and $S_{P'}$ are not conducting (OFF) is given in Fig. 2(d). In this mode inductors L_P and $L_{P'}$ gets discharged. The capacitors C_{P1} , C_{P3} and C_{P5} are charged by series combination V_{in} , L_P , C_{P2} and C_{P4} . The capacitors $C_{P'1}$, $C_{P'3}$ and $C_{P'5}$ discharge through the path V_{in} , inductor $L_{P'}$ diodes D , $D_{P'2}$ and $D_{P'4}$ to charge the capacitors $C_{P'}$, $C_{P'2}$ and $C_{P'4}$. The diodes D_{P1} , D_{P3} , D_{P5} , D , $D_{P'2}$ and $D_{P'4}$ are forward biased and the diodes D_{P2} , D_{P4} , $D_{P'1}$, $D_{P'3}$ and $D_{P'5}$ are reversed biased.

$$VC_{P1} = V_{in} - L_P(17)$$

$$VC_{P1} + VC_{P3} = V_{in} - L_P + VC_{P2}(18)$$

$$VC_{P1} + VC_{P3} + VC_{P5} = V_{in} - L_P + VC_{P2} + VC_{P4}(19)$$

$$VC_{P'} = V_{in} - VL_{P'}(20)$$

$$VC_{P'} + VC_{P'2} = V_{in} - VL_{P'} + VC_{P'1}(21)$$

$$VC_{P'} + VC_{P'2} + VC_{P'4} = V_{in} - VL_{P'} + VC_{P'1} + VC_{P'3}(22)$$

4) Mode 4: When S_P is OFF and $S_{P'}$ is ON

The equivalent circuit of the proposed converter when switch S_P is not conducting (OFF) and switch $S_{P'}$ is conducting (ON) is given in Fig. 2(e). In this mode inductors L_P gets discharged. The capacitors C_{P1} , C_{P3} and C_{P5} are charged by series combination V_{in} , L_P , C_{P2} and C_{P4} . Voltage of the capacitors $C_{P'}$, $C_{P'2}$ and $C_{P'4}$ make the diodes $D_{P'1}$, $D_{P'3}$ and $D_{P'5}$ forward biased. The capacitors $C_{P'}$, $C_{P'2}$ and $C_{P'4}$ discharge through the path of diodes to charge the capacitors $C_{P'1}$, $C_{P'3}$ and $C_{P'5}$. In this mode the diodes D_{P1} , D_{P3} , D_{P5} , $D_{P'1}$, $D_{P'3}$ and $D_{P'5}$ are forward biased and the diodes D_{P2} , D_{P4} , D , $D_{P'2}$ and $D_{P'4}$ are reversed biased.

$$VC_{P1} = V_{in} - L_P(23)$$

$$VC_{P1} + VC_{P3} = V_{in} - L_P + VC_{P2}(24)$$

$$VC_{P1} + VC_{P3} + VC_{P5} = V_{in} - L_P + VC_{P2} + VC_{P4}(25)$$

$$VC_{P'} = VC_{P'}(26)$$

$$VC_{P'1} + VC_{P'3} = VC_{P'} + VC_{P'2}(27)$$

$$VC_{P'1} + VC_{P'3} + VC_{P'5} = VC_{P'} + VC_{P'2} + VC_{P'4}(28)$$

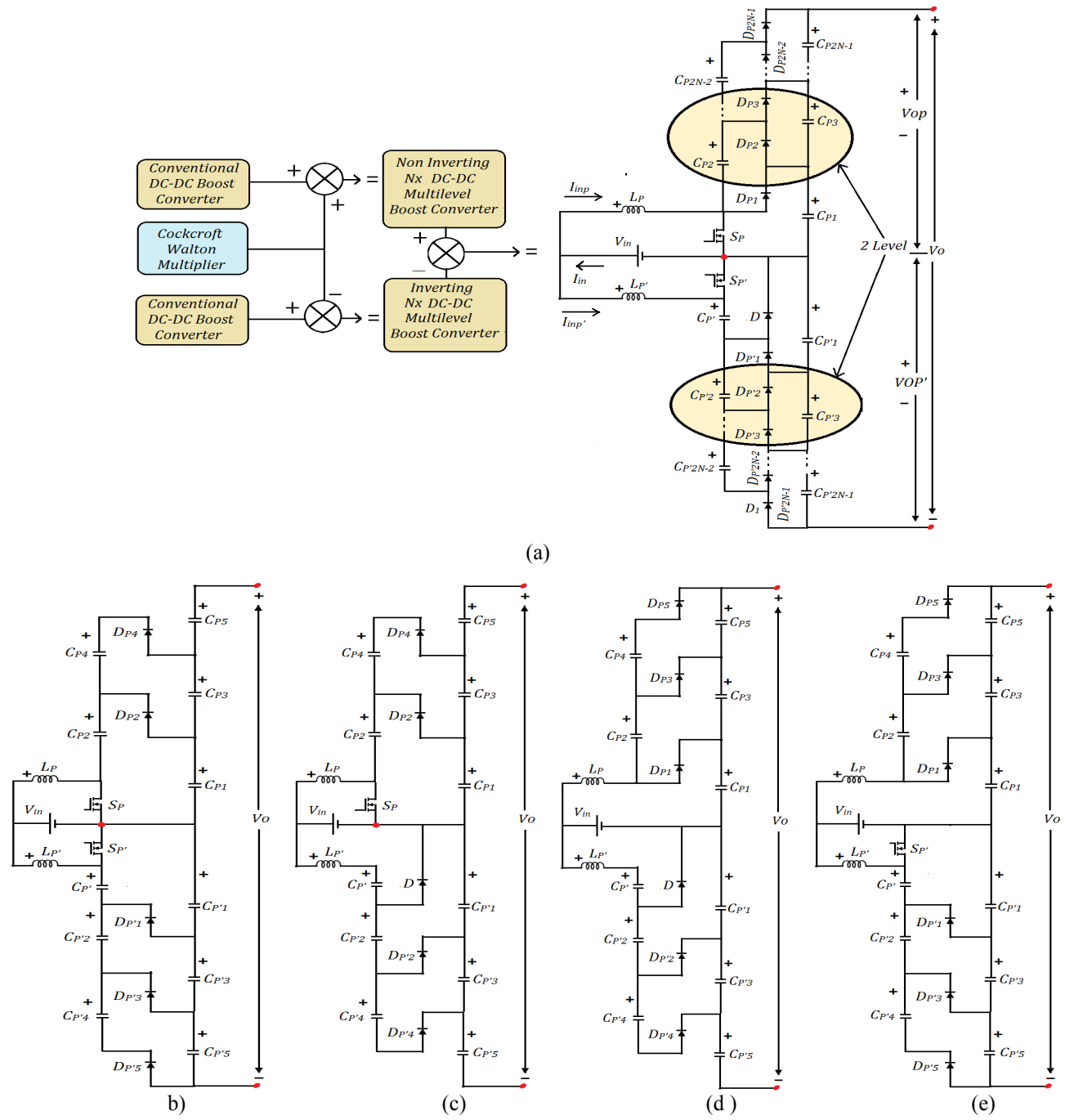

Fig. 2 (a) Presented $2N_x$ Interleaved Boost Converter (b) Equivalent circuit when both switches S_p and $S_{p'}$ are ON (c) Equivalent circuit when switch S_p is ON and switch $S_{p'}$ is OFF (d) Equivalent circuit when both switches S_p and $S_{p'}$ are OFF (e) Equivalent circuit when switch S_p is OFF and switch $S_{p'}$ is ON.

III. COMPARISON OF INTERLEAVED BOOST DC-DC CONVERTER WITH EXISTING HIGH GAIN CONVERTERS

The presented interleaved converter topology was compared with several existing non-isolated DC-DC boost converter topologies and it was examined that the $6x$ interleaved converter has higher gain than the existing non-isolated DC-DC converter at given duty cycle. Graph of voltage gain versus duty cycle for all DC-DC converters discussed in this paper is shown in Fig. 3. Thus the presented converter topology provides a viable solution to boost the voltage with high conversion ratio for renewable energy applications. In Table III a potential difference

between drain and source (V_{DS}) terminal of switch in the presented interleaved converter is compared with recent DC-DC converter. It is observed that in the presented interleaved DC-DC converter the potential difference between the drain and source (V_{DS}) terminal of the switch is very low. Thus low rating components are suitable to design the presented interleaved converter.

IV. NUMERICAL SIMULATION, RESULTS AND DISCUSSION

The interleaved converter for three levels ($6x$ Interleaved Boost Converter) has been simulated in MATLAB with designed parameters given in Table IV. Time courses of output voltage, load current and power are shown in Fig. 4(a).

TABLE II. COMPARISON OF VOLTAGE GAIN AT VARIOUS DUTY CYCLE.

Converter Type	Voltage Gain of Converter at Various Duty Cycle								
	0.1	0.2	0.3	0.4	0.5	0.6	0.7	0.8	0.9
Conventional Boost Converter	1.11	1.25	1.43	1.67	2.00	2.50	3.33	5.00	10.00
Switched Inductor (SI) Boost Converter	1.22	1.50	1.86	2.33	3.00	4.00	5.67	9.00	19.00
Single switch Quadratic Boost Converter	1.23	1.56	2.04	2.78	4.00	6.25	11.11	25.00	100.00
Conventional Three Level Boost Converter	2.22	2.50	2.86	3.33	4.00	5.00	6.67	10.00	20.00
Quadratic Three Level Boost Converter	1.23	1.56	2.04	2.78	4.00	6.25	11.11	25.00	100.00
Converters using bootstrap capacitors and boost inductors	3.44	4.00	4.71	5.67	7.00	9.00	12.33	19.00	39.00
Switched Capacitor Based Boost Converter	1.22	1.50	1.86	2.33	3.00	4.00	5.67	9.00	19.00
Two-phase quadrupled interleaved Boost Converter	4.44	5.00	5.71	6.67	8.00	10.00	13.33	20.00	40.00
High-voltage gain two-phase interleaved Boost Converter using one VMC	2.22	2.50	2.86	3.33	4.00	5.00	6.67	10.00	20.00
Extra High Voltage (HV) DC-DC Converter	4.44	5.00	5.71	6.67	8.00	10.00	13.33	20.00	40.00
4x Multilevel Boost Converter (MBC)	4.44	5.00	5.71	6.67	8.00	10.00	13.33	20.00	40.00
4x Multilevel BuckBoost Converter (MBBC)	3.44	4.00	4.71	5.67	7.00	9.00	12.33	19.00	39.00
6x interleaved Boost Converter	6.66	7.5	8.57	10	12	15	20	30	60

TABLE III. TABULATION OF VOLTAGE STRESS ACROSS SWITCHES.

Converter Type	Voltage Stress
Conventional Boost Converter	V_o
Switched Inductor (SI) Boost Converter	V_o
Single switch Quadratic Boost Converter	V_o
Conventional Three Level Boost Converter	$V_o/2$
Quadratic Three Level Boost Converter	$V_o(1-D)$, $V_o - V_o(1-D)$
Converters using bootstrap capacitors and boost inductors	V_o
Switched Capacitor Based Boost Converter	$V_o/(1-D)$
Two-phase quadrupler interleaved boost converter	$V_o/4$
High-voltage gain two-phase interleaved boost converter using one VMC	$V_o/2$
Extra high voltage (HV) DC-DC converter	$V_o/4$
4x Multilevel Boost Converter (MBC)	$V_o/4$ or $V_{in}/(1-D)$
4x Multilevel BuckBoost Converter (MBBC)	$V_{in}D/(1-D)$
6x interleaved boost converter (presented Topology)	$V_o/6$ or $V_{in}/(1-D)$

It is observed that the required 150 V output voltage is obtained at the required output power 100 W for a duty cycle of 0.60. Fig. 4(b) shows the output voltage ripple across load and it is observed that the voltage ripple is 0.6 V. Load current ripple across load is shown in Fig. 4(b). It is also observed that 2.5 mA ripple is present in the load current. The voltage stress across switch S_p and $S_{p'}$ is shown in Fig. 4(c). It is noted that the voltage stress of switches S_p and $S_{p'}$ is equal to $V_o/6$ i.e. 25V. For N level presented topology voltage stress across switch is $V_o/2N$ volts. The voltage at different output level is shown in Fig. 4(d). It is observed that voltage at first, second and third level is 50 V, 100 V and 150 V, respectively. Hence each level contributes by the same voltage which is equal to 50 V. For the N level presented topology each level contributes to voltage by V_o/N volts. The voltage distribution across all upper capacitors (C_{P1} , C_{P2} , C_{P3} , C_{P4} and C_{P5}) is shown in Fig. 4(e) and the voltage distribution across all capacitors is the same and equal to 25 V. The voltage

TABLE IV. MAIN PARAMETER OF NUMERICAL SIMULATION TEST.

Input Voltage	10 V
Output Voltage	150V
Power, Load	100W, 225 Ohm
Inductance, Capacitance	150uH, 220uF
Duty Cycle	60%
Switching frequency	50kHz

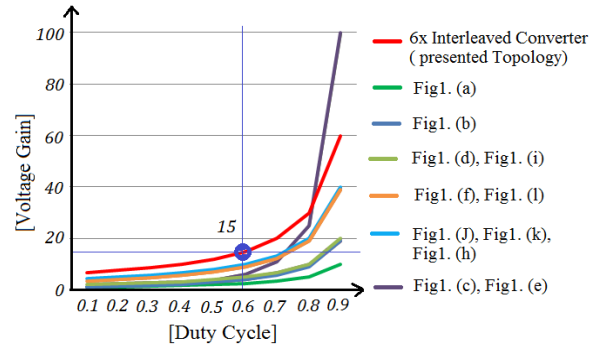

Fig. 3. Voltage gain versus duty cycle

distribution across all lower capacitors ($C_P, C_{P'1}, C_{P'2}, C_{P'3}, C_{P'4}$ and $C_{P'5}$) is shown in Fig. 4(f) and the voltage distribution across all capacitors is same and equal to 25 V. The voltage distribution across all multiplier capacitors shows that the converter performs satisfactorily. The proposed $2N_x$ interleaved converter is highly desired in renewable energy generation systems because of a low ripple and high conversion ratio.

V. CONCLUSIONS

Hybrid non isolated and non-inverting Cockcroft-Walton multiplier based $2N_x$ Interleaved Boost Converter ($2N_x$ IBC) presented with working modes which offers a viable solution for renewable energy applications. The presented $2N_x$ interleaved boost converter circuit is a combination of a non-inverting N_x multilevel boost converter and inverting N_x

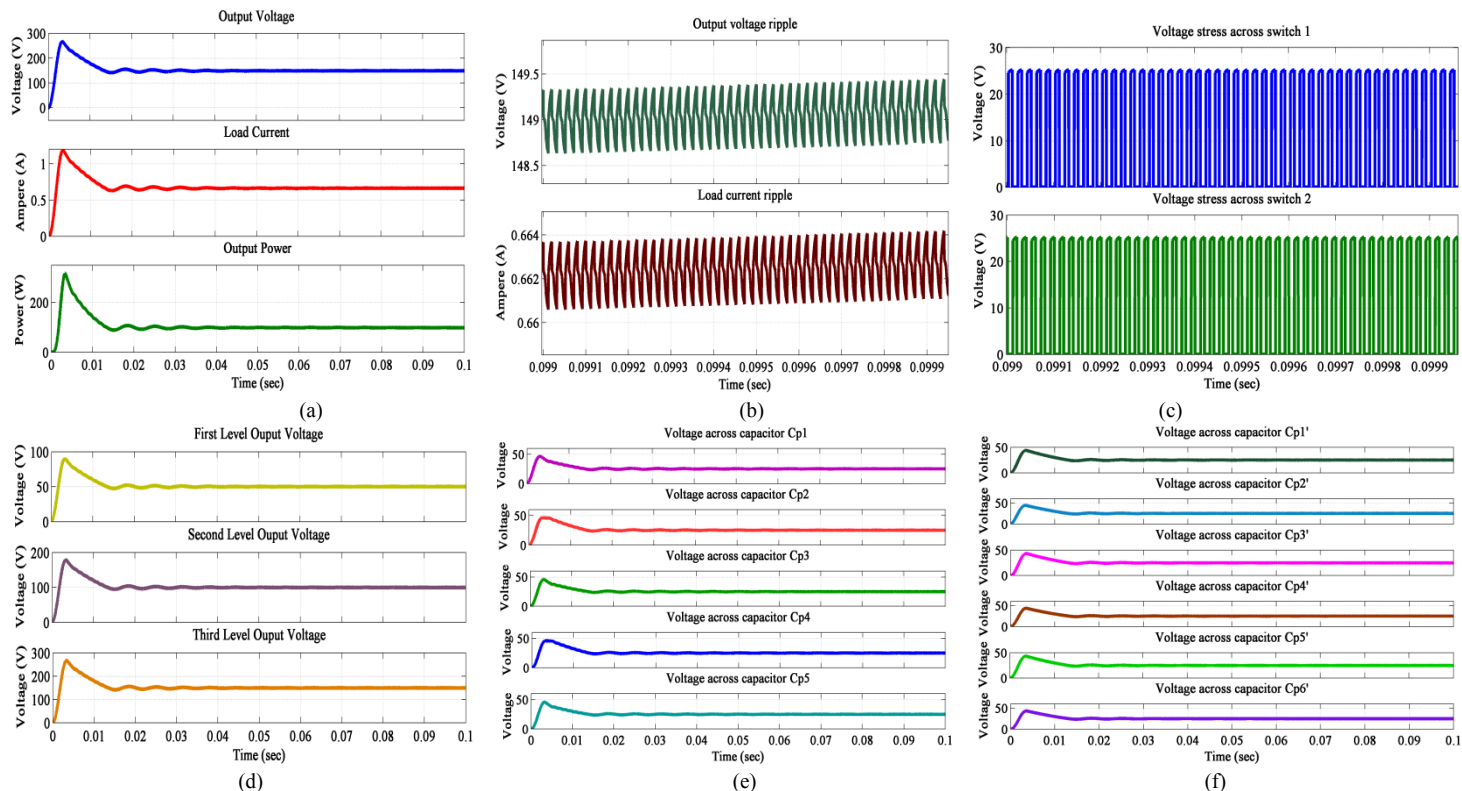

Fig.4.Simulation Results of presented topology for input voltage 10 V, power 100W,output voltage 150 V, duty cycle 60 %, switching frequency 50 kHz. 225 Ohm load (a) output voltage, load current and power (b) output voltage ripple and load current ripple. (c)voltage stress across switch S_P and S_P (d)voltage at different output level (e) voltage distribution across upper capacitors (C_{P1} , C_{P2} , C_{P3} , C_{P4} and C_{P5}) (f) voltage distribution across lower capacitors (C_P , C_{P1} , C_{P2} , C_{P3} , C_{P4} and C_{P5}).

Multilevel Boost Converter. The presented converter is compared with recent non isolated DC-DC converter and it has a low voltage stress across switching devices and high conversion ratio compared to recent derived non isolated converter for the same duty ratio. Reliability of the converter is higher in comparison with converters having several synchronized switches. It is possible to increase the conversion ratio by adding capacitor and diode circuitry without disturbing the main circuit. Based on simulation results it is possible to conclude that it is a promising topology for renewable energy applications like automotive renewable appliances and electrical vehicles.

ACKNOWLEDGMENT

This work was supported by the Scientific Grant Agency of the Slovak Republic under the Contract no. VEGA 1/0464/15.

REFERENCES

- [1] W. Li, X. He, "Review of non-isolated high step-up dc/dc converters in photovoltaic grid-connected applications", *IEEE Trans. Ind. Electron*, vol. 58, no. 4, pp. 1239-1250, Apr. 2011.
- [2] F.L.Tofoli, P.Dênis de Castro, W.Josias de Paula, O.J.Demercil de Sousa, "Survey on non-isolated high-voltage step-updc-dc topologies based on the boost converter", *IET Power Electron.*, pp. 1-14, July 2015.
- [3] L.S. Yang, T. J. Liang, J. F. Chen, "Transformerless dc-dc converters with high step-up voltage gain", *IEEE Trans. Ind. Electron*, vol. 56, no. 8, pp. 3144-3152, Aug. 2009.
- [4] J.P.M.Figueiredo, F.L.Tofoli, R.L.Alves, "Comparison of nonisolated dc-dcconverters from the efficiency point of view", *Proc. Brazilian Power Electronics Conf.*, pp. 14-19, 2011.
- [5] Y.R. de Novaes, A.Rufer, I.Barbi, "A new quadratic, three-level, dc/dc converter suitable for fuel cell applications", *Proc. Power Conversion Conf.*, pp. 601-607, 2007.
- [6] B.R.Lin, L.Hsin-Hung, "Single-phase three-level PWM rectifier", *Proc. IEEE Int. Conf. on Power Electronics and Drive Systems*, pp. 63-68, 1999.
- [7] B.Axelrod, Y.Berkovich, A.Ioinovici, "Transformerless dc-dc converters with a very high dc line-to-load voltage ratio", *Proc. Int. Symp. on Circuits and Systems*, pp. III-435-III-438, 2003.
- [8] C.T.Chuang, C.F. Chu, "A novel transformer-less adaptable voltage quadrupler dc converter with low switch voltage stress", *IEEE Trans. Power Electron.*, vol. 29, no. 9, pp. 4787-4796, 2014.
- [9] R.Gules, L.L.Pfiftcher, L.C.Franco, "An interleaved boost dc-dc converter with large conversion ratio", *Proc. IEEE Int. Symp. on Industrial Electronics*, pp. 411-416, 2003.
- [10] P.Sanjeevikumar, A.Iqbal, H.Abu-Rub, "Implementation and control of extra high voltage dc-dc boost converter", *The 7th IET Intl. Conf. on Sustainable Energy and Intelligent Systems, IET-SEISCON'14*, Chennai (India), 12-14 Dec. 2013.
- [11] P.Sanjeevikumar, E.Kabalcı, A.Iqbal, H.Abu-Rub, O.Ojo, "Control Strategy and Hardware Implementation for DC-DC Boost Power Conversion Based on Proportional-Integral Compensator for High Voltage Application", *Engg.Science and Tech.: An Intl. J. (JESTECH).Elsevier J. Pub.*, vol. 18, no. 2, pp. 163-170, 25 Nov. 2014.
- [12] P.Sanjeevikumar, K.Rajambal, "Extra high voltage DC-DC boost converters with simplified control strategy", *Intl. J. of Modeling and Simulation, Hindawi Pub. Corp.*, US, vol. 2008, Article ID 593042, 8 pages, Jan. 2008.
- [13] P.Sanjeevikumar, G.Grandi, P.WWheeler, F.Blaabjerg, J.Loncarski, "A Simple MPPT Algorithm for Novel PV Power Generation system by High Output Voltage DC-DC Boost Converter", *Conf. Proc., 24th IEEE International Symposium on Industrial Electronics, IEEE-ISIE '15*, Rio de Janeiro (Brazil), pp. 214-220, 3-5 Jun. 2015.
- [14] J.C.Rosas-Caro, J.C.Mayo-Maldonado, R.S.Cabrera, A.G.Rodriguez, S.C.Eduardo Nacu, R.Castillo-Ibarra "A Family of DC-DC Multiplier Converters", *Advance online publication*: 10 Feb. 2011.