

MODELLING AND ANALYSIS OF A RADIO FREQUENCY DIELECTRIC HEATING FOR DEFATTED SOY FLOUR

HP van der Walt, BS Paul and DV Nicolae

Electrical and Electronic Engineering Technology Department, University of Johannesburg, South Africa

ABSTRACT

In this paper a Radio Frequency (RF) method for drying defeated soy flower is developed using a class E amplifier. The raw and uncooked soy flour contains a few undesirable inherent soybean enzymes. Minimizing the content and effect of these enzymes usually is done through “drying/heating” methods. The method used in this study is “RF dielectric heating”.

Modelling, simulation and implementation results complete the paper.

KEY WORDS

Dielectric heating, Modelling and simulation, Class E amplifier

1. Introduction

Soya beans are an important component of the earth’s food supply, and much interest is manifest in their processing for human consumption. The raw and uncooked soy flour contains a few undesirable inherent soybean enzymes, such as:

- Lipoxygenase: an enzyme that catalyses the oxidation of polyunsaturated fatty acids to form a peroxide of the acid [1] [2].
- Trypsin inhibitor [2] [8]: small protein synthesized in the exocrine pancreas which prevents conversion of trypsinogen to trypsin, so protecting itself against trypsin digestion. Pancreatic trypsin inhibitor competitively binds to the active site of trypsin and inactivates it at a very low concentration. The binding is amongst the strongest noncovalent associations, but only a fraction of the potential trypsin is so inhibited [8].
- Urease: an enzyme that catalyses the decomposition of urea to ammonia and carbon dioxide [9].

Fortunately, these enzymes can be deactivated by either moist or dry heat [10]. The former is more effective but requires further costly drying steps.

The reduction in the activity of these enzymes can easily be measured in a laboratory. Urease requires a longer heat treatment than trypsin inhibitor to be deactivated [8] [10]. Therefore, many laboratories use the urease test to monitor the destruction of the other harmful enzymes [1, 2, 3, 8, 9, 10].

Minimizing the content and effect of these enzymes usually is done through “drying/heating” methods. There are several methods in use to dry grain products, for example:

- Hot-air drying process, it is when food is dried, hot dry air comes into contact with the grain, the hot air removes the moisture from the grain products, and during the process the new hot air will continue until all the moisture is removed [10].
- Resistive/ohmic heating (sometimes also referred to as Joule heating, electrical resistance heating, direct electrical resistance heating, electro heating, and electro-conductive heating) is defined as a process wherein (primarily alternating) electric currents are passed through foods or other materials with the primary purpose of heating them. The heating occurs in the form of internal energy generation within the material [10, 11].
- Infrared heating: infrared energy is simply absorbed and converted to heat to the extent of heating by radiant energy and depends on surface characteristics and colour of food and used to alter the eating qualities by changing the surface colour, flavour and aroma.
- Radio-frequency (RF) dielectric heating or microwave dielectric heating, induces molecular friction in mater molecules to produce heat, is determined in part by the moisture content of food [4, 5, 10, 12]. The basic arrangement for a dielectric heating system is that of a capacitor in which the material to be heated due to the dielectric stress. The heat generated in the material is proportional to the loss factor, which is the product of the dielectric constant and the power factor. The power factor of most dielectric materials is quite low at low frequencies therefore the range of frequencies employed for dielectric heating extends from a few MHz to a few GHz [5, 6, 7]. More specific, in [4], The US Federal Communications Commission (FCC), has allocated some frequencies for industrial applications 13.56 MHz, 27.12 MHz and 40.68 MHz and.

Further, in second section, this paper analyses soy flour as a dielectric under high frequency electromagnetic field. Chapter 3 analyses RF method for drying defeated soy flower is developed using a class E amplifier followed by modelling and simulation. Experimental model implementation and practical results complete the paper.

2. Problem definition

2.1 Soy flour as dielectric

From electric point of view, soy flower is a dielectric. The term dielectric comes from dia- (“through”) + electric [7]. The term “isolator” means that the material will have a

very low electrical conduction whereas the term “dielectric” is used to describe materials with very high polarization ability, which sometimes is called the dielectric constant of a material. A good example of a dielectric is the insulating material between the two metal plates of a capacitor. In this study, a cylindrical capacitor filled with soy flower was built for measurements and tests.

Most food, grain and soy products behave like capacitors with loss dielectrics, the fact that it can store electrical energy when subjected to an electric field make them behave like capacitors and dissipate electrical energy in the form of heat like resistors do. The ability to dissipate electrical energy and store energy can be linked to the dielectric properties of the dielectric material that depend on the electric field frequency.

The dielectric properties of a material can be described in terms of the complex permittivity:

$$\varepsilon^* = \varepsilon' - j\varepsilon'' \quad (1)$$

The real part ε' of the relative permittivity, also known as the relative dielectric complex constant and it refers to the ability of the dielectric material to store energy in the presence of an electric field. The relative permittivity $\varepsilon' = 1$ and is constant for hundreds of MHz [13] [17]. The imaginary part ε'' , also known as the relative electric loss factor and it refers to the ability of the dielectric material to store energy when an electric field is connected, which results in heat generation. The dielectric constant and loss factor of biological materials are dependent on the following factors: temperature, frequency and composition. A too high loss factor would result in small penetration depths, which cause skin heating and if the loss factor is low the material is transparent to the electromagnetic wave [13-17].

$$\varepsilon'' = \varepsilon_d'' + j\varepsilon_\sigma'' = \varepsilon_d'' + \frac{\sigma}{2\pi f \varepsilon_0} \quad (2)$$

where, subscripts d and σ stand for dipole rotation and ionic conduction (S/m); f is the frequency of the electromagnetic wave in Hz, ε_0 is the permittivity of free space ($8,842 \cdot 10^{-12}$ F/m). The dielectric loss factor ε'' can be expressed as:

$$\varepsilon'' = \varepsilon' \tan \delta = \varepsilon' \tan \left(\frac{\sigma}{2\pi f \varepsilon_0} \right) \quad (3)$$

Where $\tan \delta$ is an indication of the power loss in a dielectric material and it called the loss angle of the dielectric material. When the loss angle is greater than 10 the material is then called a good conductor and when it is smaller than 1 it is referred to as a good insulator [16].

When an electromagnetic waveform is connected to a biological material, part of the electromagnetic energy is absorbed by the material and converted into heat. The power absorbed in a dielectric material depends on the dielectric properties (loss factor), frequency and electric field strength of the electromagnetic wave connected to the material.

$$P = 2 \cdot \pi \cdot f \cdot \varepsilon_0 \cdot \varepsilon' \cdot \tan \delta \cdot E^2 \quad (4)$$

where, P is the power per unit volume in W/m^3 , E is the electric field strength in V/m . The typical loss factor is between 2 and 100, to evaporate the moisture content in a material it will be find that the energy processes have to include the latent heat component in the formula [5] [6].

2.2 Analysis of soy dielectric constant at high frequency

As presented before, any dielectric (soy flower in this case) has permittivity (ε) depending on frequency. The test cylindrical capacitor/canister filled with soy flower was connected to an impedance meter TE 1000 in order to determine the electrical parameters in the megahertz range (Figure 1). The results are presented in Figure 2, 3, 4 and Table 1.

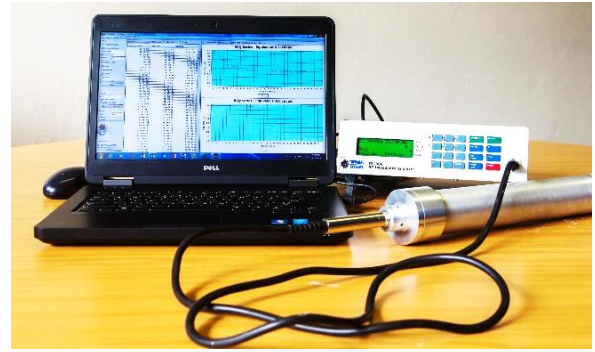

Figure 1. Testing system

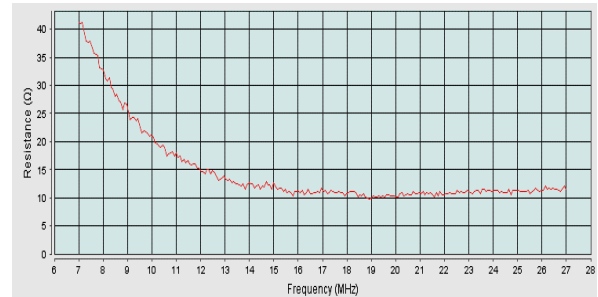

Figure 2. Equivalent series resistance versus frequency

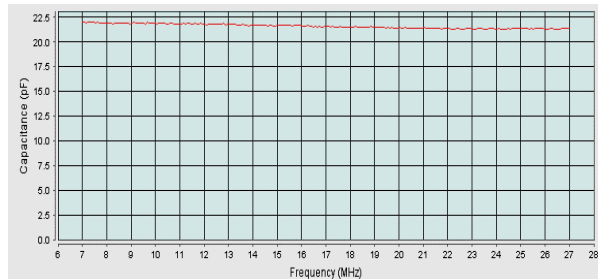

Figure 3. Capacitance versus frequency

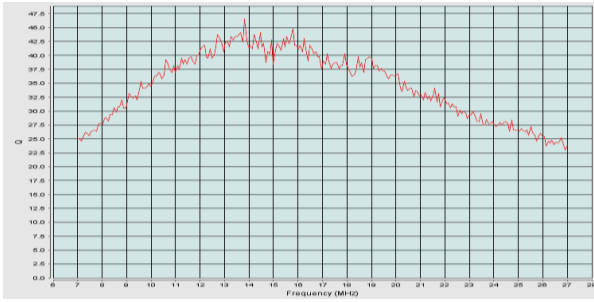

Figure 4. Quality versus frequency

Table 1. Soy Flour equivalent parameters for some recommended frequencies

Frequency (MHz)	Series Resistance (Ω)	Capacitance (pF)	Reactance (Ω)	Quality Factor	Relative Permittivity
9.04	25.2	22.1	-802	31.2	2.47
13.56	12.3	21.8	-539	43.7	2.47
27.12	11.7	20.9	-276	22.5	2.47

For this application the recommended frequency of 13.56 MHz was used.

2.3 Finite Elements Analysis

Further and assuming that we can generate an electromagnetic field of 200 V peak value at 13.56 MHz, Finite Elements Analysis (QuickField) was used to determine the electromagnetic field distribution into the soy flour in the testing device. Figures 5 and 6 show the radial distribution of main electromagnetic parameters.

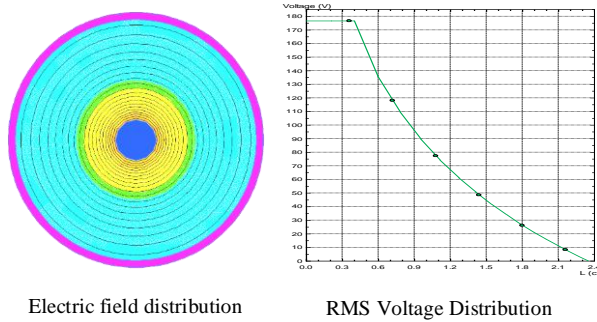

Figure 5: Electric field distribution

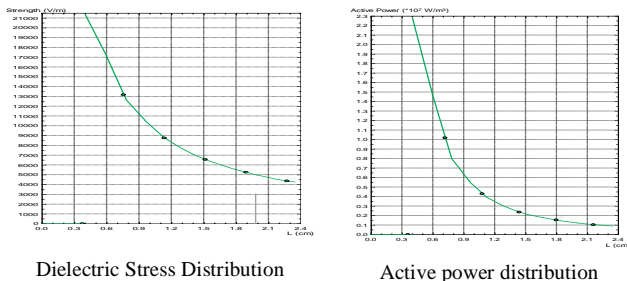

Figure 6: Stress parameters

3. Radio Frequency Generator

As mentioned before [4, 5, 6, 7], the method of dielectric heating implies applying a high frequency electric field upon the soy flour. The power dissipated in the soy flour depends not only on the frequency but also the level of electric field density E see eq. (4); the higher E is more power is dissipated. The high level of E is obtained using a radio frequency generator coupled with an RF amplifier. The amplifier could be linear [18] or class E [19-22] or class C-E [19].

3.1 Class E Amplifier

Figure 7 shows a Class E amplifier slightly modified; the resistive load R_L from the classis topology was removed and entire power to be dissipated on internal R_s resistance of the soy flour.

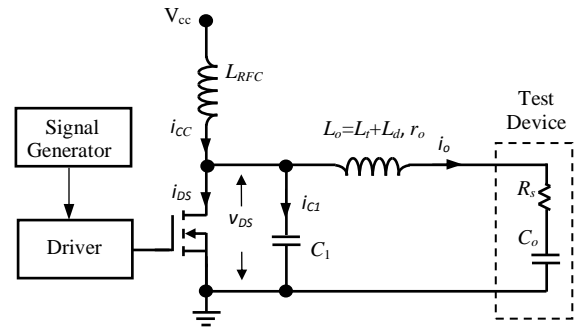

Figure 7. Class E Simplified diagram

3.2 Frequency domain analysis

To find the values of the parameters of this amplifier, we analyse the model in frequency domain. During this analysis were used measured parameters as recommended from [12], [20]: operating frequency of 13.56 MHz, quality factor of the test sample of 43.7 and equivalent impedance of: $Z_{eq} = 12.3 - j539 \Omega$

Series inductor L_o in our diagram is formed from the tuning inductor L_t and a virtual “detuning” inductor L_d [12], [20]:

$$L_o = L_t + L_d \quad (5)$$

The value of tuning inductor is given from the resonant condition with capacitive reactance:

$$\omega L_t = X_{C-o} = 539 \quad (6)$$

$$L_t = \frac{899}{2 \times \pi \times 9.04 \times 10^6} = 6.33 \mu H \quad (7)$$

Detuning inductor could be determined as [12], [20] taking its quality factor of 10:

$$\omega L_d = \frac{1.11 \times Q \times R_s}{Q - 0.67} = \frac{1.11 \times 10 \times 12.3}{10 - 0.67} = 14.36 \ \Omega \quad (8)$$

$$L_d = \frac{14.63}{2 \times \pi \times 13.56} 10^{-6} = 0.17 \ \mu H \quad (9)$$

Hence:

$$L_o = L_t + L_d = 6.5 \ \mu H \quad (10)$$

Loaded quality factor Q_L :

$$Q_L = \frac{2 \cdot \pi \cdot f_o \cdot L_o}{R_s} = 45 \quad (11)$$

Now, the value of the capacitor C_1 together with output capacitance of the switch/mosfet, used in our application (ARF446_ $C_{oss} = 90$ pF), could be determined [12], [20]:

$$\omega(C_1 + C_{oss}) = \frac{0.1836}{R_s} \left(1 + \frac{0.81 Q_L}{Q_L^2 + 4} \right) = 0.0152 \ \Omega \quad (12)$$

$$C_1 = \frac{0.0152}{2 \times \pi \times 13.56 \times 10^6} - 90 \times 10^{-12} = 88 \ \text{pF} \quad (13)$$

According to [20], [21], [22] the value of L_{FRC} should be “large enough”; for this application we chose:

$$L_{FRC} = 120 \ \mu H \quad (14)$$

3.3 Simulation validation

The results-value of critical components obtained during frequency analysis have been included into a “SIMetrix” model (see Figure 9) supplied from a 12 V power supply.

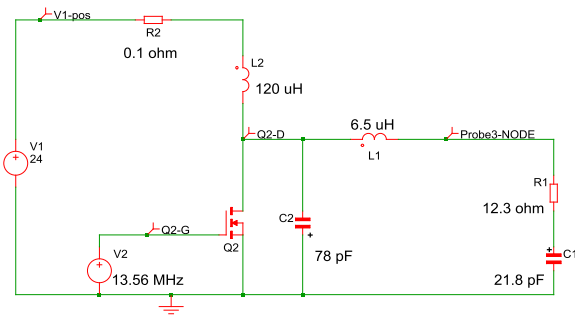

Figure 9. Simulation model

Signal generator provided a $5V_{pp}$, 13.56 MHz with 50% duty cycle to drive the switch/mosfet. The parameters monitored were the voltage across “canister test” $R_s C_o$, drain voltage, supply current shown in Figures 9, 10 and 11.

From Figure 12 one can observe $V_{out-rms} = 384$ V, $I_{out-rms} = 0.689$ A and that the average-active power (brown trace) into resistive part of the test device is 6.38 W which results in power factor of $\cos \varphi = 0.024$ leading. This

value is in concordance with the measurements done for soy flour parameters at 13.56 MHz:

$$Z_{eq} = 12.3 - j539 = 539.1 \angle -88.69^\circ \ \Omega$$

Which gives:

$$\cos(88.69^\circ) = 0.0229$$

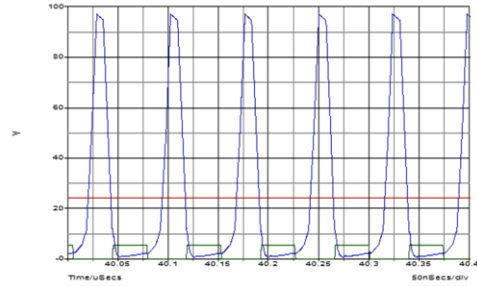

Figure 10 Drain-source voltage (blue), input signal (green) and supply voltage (red)

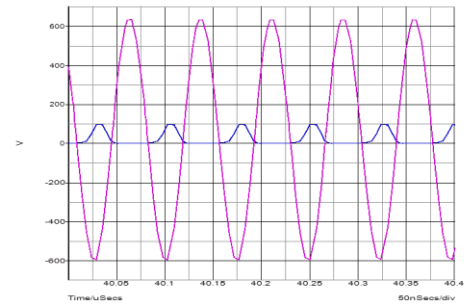

Figure 11 Drain-source voltage (blue) and output voltage (pink)

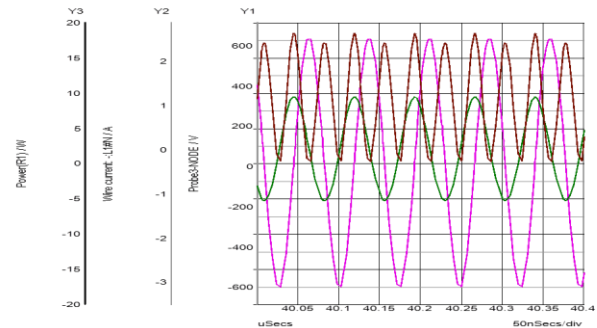

Figure 12 Output parameters: voltage (pink), current (green) and power (brown)

4. Experimental Validation

Figure 13 shows experimental setup. For measurement, Tektronix DS5104 oscilloscope has been used. The parameters examined were main switch (Figure 14), drain-source voltage and output voltage (Figure 15) and output parameters: voltage (pink) and current (green) (Figure 16).



Figure 13. Experimental set up.

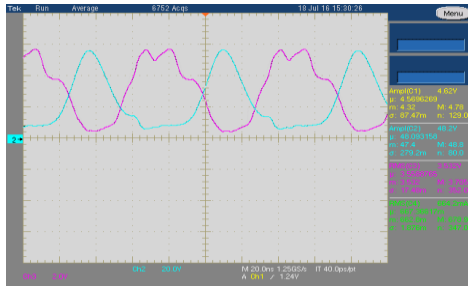

Figure 14. Switch parameters: gate (pink) drain-source voltage (blue)

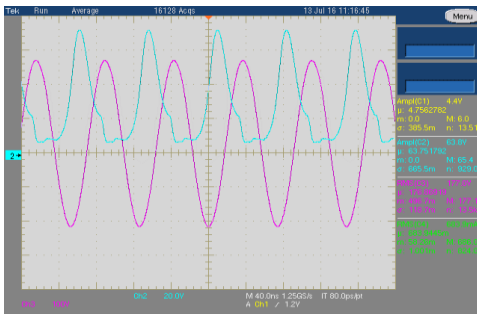

Figure 15. Output voltage (pink) and drain-source voltage (blue)

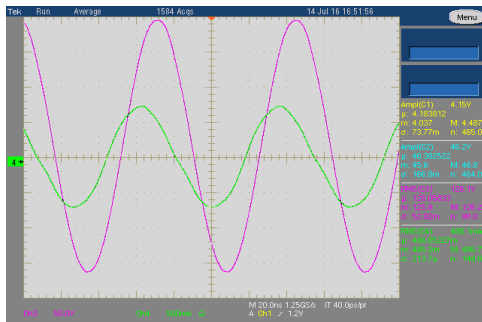

Figure 16 Output parameters: voltage (pink) and current (green)

After settling the tuning of the RF Heater on 13.56 MHz and running for about 30 minutes, the temperature distribution was firstly evaluated with thermal camera ESAIR-0 and the result could be observed in Figure 17.

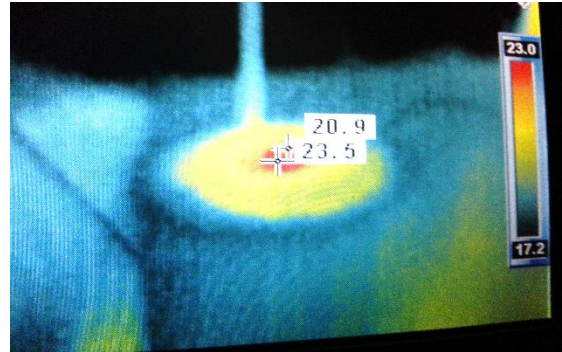

Figure 17 Apparent temperature distribution

The testing device is thermal isolated and the reading of thermal camera appears on the top disc and central copper rod. From this picture could be seen a non-uniform radial temperature distribution as was foreseen during the finite elements analysis (see Figure 6 about active power distribution).

Then a thermocouple probe was introduced into the soy flour and the reading of the temperature can be observed in Figure 18. There is some uncertainty about this result due to the fact that the position of the probe was not very well defined.



Figure 18 Soy flour temperature after 30 minutes

5. Conclusions

This paper presented design, simulation and implementation of radiofrequency generator based on class E amplifier. The experimental results resemble simulation even with some differences; simulation model could not take effect of too many parasitic elements present in the experimental model.

The temperature induced into soy flour is significant as could be seen in Figure 18.

All these results validate the concept of RF heating using this cost effective generator described, designed and implemented in this study.

REFERENCES

- [1] E. Danielson, Addition of Soybean Lipoxigenase to All-Purpose Flour and Its Effect on Dough Gluten Strength and Bread Quality, Thesis-Master of Science, 2007, Virginia Polytechnic Institute
- [2] W.J. Wolf, Soybean Proteins: Their Functional, Chemical and Physical Properties, Journal for Agricultural Food Chemistry, Vol. 18, No: 6, pp: 969-976, 1970
- [3] E.D. Rodda, M.P. Steinberg and L.S. Wei, Soybean Damage Protection and Evaluation For Food Use, Trans, Amer. Agric. Eng., Vol 16, No: 2, pp: 365-373, 1973
- [4] Y. Wang, Y. Li, S. Wang and Li Zhang, Review of dielectric drying of foods and agricultural products, International Journal for Agric. & Bio. Eng. Vol. 4, no: 1, pp. 1-19, 2011
- [5] S.O. Nelson, Review and Assessment of Radio-Frequency and Microwave Energy for Stored-Grain Insect Control, Transactions of the ASAE, Vol. 39, pp: 1475-1484, 1996
- [6] S.O. Nelson, Agricultural Applications of Dielectric Measurements, IEEE Trans. On Dielectric and Electrical Insulations, Vol. 13, No. 4, pp. 688-702, Aug. 2006
- [7] Wang S; Tang J; Johnson J A; Mitcham E; Hansen J D; Hallman G; Drake S R; Wang Y, DIELECTRIC PROPERTIES OF FRUITS AND INSECT PESTS AS RELATED TO RADIO FREQUENCY AND MICROWAVE TREATMENTS, Bio-systems Engineering (2003) 85 (2), 201-212
- [8] D.L. Hwang, D.E. Foard, and C.H. Wei. (1977), A Soybean Tripsin Inhibitor. The Journal of Biological Chemistry. Vol. 252, No. 3, pp: 1099-1107, 1977
- [9] J. Kirk, The Concentration of Soy Bean Urease- A New Method for the Purification of Enzymes, *The Journal of Biological Chemistry*, Vol. C, No. 3, 667-677, 1933
- [10] A.K. Smith and S.J. Circle, Soybeans: *Chemistry and Technology*, Westport, Connecticut: AVI Publishing Co. 1972
- [11] M. Adonis and MTE Khan, Combined Convective and Infrared Drying Model for Food Applications, 7th AFRICON Conference in Africa, Vol. 2, pp. 1049-1052, Botswana, Gaborone 15-17 Sept. 2004
- [12] HC van Zyl Pienaar (November 2002). Design and Development of a Class E Dielectric Blood Heater, Doctoral Thesis, 2010, Vaal University of Technology.
- [13] S. O. Nelson, Fundamentals of Dielectric Properties, Journal of Microwave Power and Electromagnetic Energy, Vol. 44, No. 2, pp: 99-109, Jan. 2010
- [14] S. L. Wang, On the Relationship between Dielectric Dissipation-Factor and Angular Frequency, Proceedings of the 3rd International Conference on Properties and Applications of Dielectric Materials, pp. 1080-1082, 1991
- [15] S. Ryyanen, A Review Of The Basic Principles, Journal of The Electromagnetic Properties of Food, Food Engineering, pp. 409-429, 1995
- [16] P. Lorrain, DR Corson and F. Lorrain F, Electromagnetic Fields and Waves, New York 1988, NY: W.H. Freeman and Company, New York, NY, H. Freeman and Company.
- [17] G.G. Raju, *Dielectrics in Fields*, ISBN: 0824708644, Marcel Dekker, New York Basel, 2003
- [18] P.B. Kenington and A. Bateman, RF Linear Amplifier Design, *Conf. Proc. RF Expo West*, pp. 223-232, March 1994, San Jose.
- [19] MK Kazimierczuk and W.A. Tabiz, Class C-E High Efficiency Tuned Power Amplifier, *IEEE Trans. On Circuits and Systems*, Vol. 36, No.3, pp. 421-428, March 1989
- [20] N.O. Sokal, Class-E High-Efficiency Power Amplifiers, From HF to Microwave, *Proceedings of the IEEE International Microwave Symposium*, Baltimore June 1998, pp.1112
- [21] H.L. Krauss, C.W. Bostian and F. H. Raab, Solid State Radio Engineering, pp. 335, 1980 (ISBN 0-471-03018-X), New York: John Wiley
- [22] T. Suetsugu and M.K. Kazimierczuk, Design Procedure of Class-E Amplifier for Off-Nominal Operation at 50 % Duty Ratio, *IEEE Trans. On Circuits and Systems*, Vol. 53, No. 7, pp. 1468-1476, July 2006