

*Proceedings of the 2016 International Conference on Industrial Engineering and Operations Management
Detroit, Michigan, USA, September 23-25, 2016*

Design of a mechanical cleaning device P.I.G (pipeline intervention gadget) connecting two transfer lines in Zimbabwe

Tawanda Mushiri

Department of Mechanical Engineering
University of Johannesburg
P.O Box APK 524
Johannesburg
South Africa

tawandanda.mushiri@gmail.com, tawandamushiri123@hotmail.com

Stephen Ndlovu

Department of Mechanical Engineering
University of Zimbabwe
P.O Box MP167
Mt Pleasant
Harare
Zimbabwe

ndlovustephenm@gmail.com

Charles Mbohwa

Faculty of Engineering and the Built Environment
University of Johannesburg
P.O Box APK 524
Johannesburg
South Africa

cmbohwa@uj.ac.za

Abstract

In the Oil and Gas Industry, maintenance is done using a device or tool called a pig, chiefly to remove solids, dirt, and liquids from the pipelines. The aim of this work is to design and retrofit a pig which will clean 3 identical underground transfer pipelines linking 2 depots. The movement of this tool is basically through the action of the fluid in the pipeline pushing it along as it is pumped from one point to another, hence no external power is needed in the device to help in its movement. Calculation based model analysis of the tool together with Solidworks simulations and results are included in detail, with all assumptions and limitations clearly stated and listed. The results show that the pig will move inside the pipe at a lower speed than the mean flow velocity which is good for the performance of the electronic systems installed on its body for pipeline inspection. Bypass hole is added on the central part of the pig body to control the speed as well as keep the cleaned dirt stirred and moving, being pushed by the pig as it performs its cleaning process.

Keywords

Pipeline Intervention Gadget, pipeline, design, transfer lines, maintenance

1. Introduction

Petroleum as a source of energy powers a vast number of vehicles as well as railway locomotives, aircraft and ships. This means it is highly valuable hence its demand in the global market is very high regardless of it being a non-

renewable energy resource. In Zimbabwe this demand as in other countries keeps increasing and hence the need for careful transportation since it is an imported product is also crucial. The fuel is transported in a pipeline system which runs all the way from the Beira port in. To the engineers the challenge is in the servicing and maintenance of the underground pipelines without disrupting or stopping the flow of the product. According to the ILS Standards use of pipeline pigs as maintenance tools is the solution to tackling these problems. To define pigging, it is a process in which a properly sized device, be it spherical or cylindrical is propelled through a pipeline by manipulating the pressure and flow of the existing media (fluid or gas) with the specific purpose of cleaning, inspecting, distributing an inhibitor and or as a plug to isolate a section of the pipeline (Varghese, 2011). A pig now can be defined as a device (or gadget) that moves through the inside of a pipeline for the purpose of cleaning, dimensioning, or inspecting (Girard Industries, 2015) .

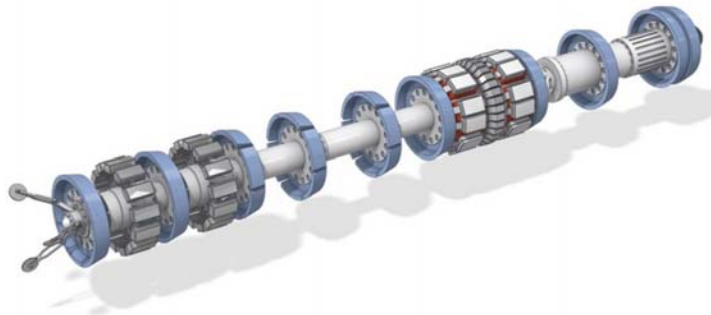

Figure 1. A modern smart/intelligent pig

A pig can be used in various pipeline industries such as gas or other related fields depending on the nature of job requirements, for example; Utility pigs, Inline Inspection tools, gel pigs and plugs. Due to technological advancements pig improvement led to the design of smart pigs, also known as, inline inspection (ILI) tools or intelligent pigs which are basically electronic devices designed to flow inside of a gas/liquid transmission pipelines, usually while the line is in service, to inspect a pipeline so as to reduce the risk of pipeline failure (Nagaraj, 7-9 July 2015).

1.1 Background

Ever since the breakthrough in the Petroleum industry in the 19th century, it has grown to successfully dominate the global economic market. Engineers in this particular field have had to deal with several challenges so as to optimize costs and at the same time maximize production and distribution. The use of pipeline technology led to problems which resulted in the invention of Pigs. The term Pig has never had a satisfactory explanation as to why it was termed that way although it is believed it came from the loud, screeching pig-like sounds as the early pigs went through a pipeline. On the other hand a theory claims its stands for Pipeline Intervention Gadget. Historically pigging applications were mainly focused in cleaning of pipelines in order to maximize the flow conditions and were basically crude in nature. However in the modern world these applications have spread throughout due to various reasons and the equipment for pigging is designed by Engineers so as to perform particular functions efficiently, reducing cost as much as possible. Also International standards such as the Indian Regulations and API 1163 have been adopted for performance checks such as servicing and deciding life span of a pipeline as well as other applications. There is need for a mechanism or device to remove dirt accumulating in the interior of the underground pipelines as well as detect corrosion, without stopping or interrupting the transfer flow.

2. Literature review

2.1 Pigs and their classification

Pigs can be classified into different categories according to their manner of job requirement or operations. These operations include removal of debris, cleaning of wax, rust and dirt, tasks such as dewatering prior to

commissioning, flooding a pipeline for hydrotest, detecting anomalies and leakages as well as other physical damages as a form of inspection. The pigs can then be grouped into 3 categories;

- Utility pigs
- In-line Inspection Tools
- Gel pigs

Utility Pigs

These pigs are basically for cleaning and sealing pipelines, hence, they can be divided into 2 categories.

1. Cleaning pigs – these are equipped with brushes or blades to remove the dirt which accumulate in the interior walls of the pipeline. The dirt can be in form of debris, wax from mainly crude products and so on. In gas pipelines, solvents in the inhibitors evaporate and form solids on pipeline walls which are removed by these cleaning pigs. Cleaning pigs can also be used in conjunction with chemical treating of lines to disturb corrosion sites and products, microbes and remove water as well as food for the microbes.
2. Sealing pigs – these may be spheres, solid cast polyurethane or mandrel type pigs used during hydrostatic testing of pipelines. They are also used in separating dissimilar products from a products pipeline and also remove water among other applications. The sealing elements are usually elastomer cups or discs used as a combination of both sealing and cleaning elements to remove soft deposits.



Figure 2. Utility pigs

In-line Inspection Tools

Also called 'intelligent' or 'smart' pigs as they provide information about the conditions as well as the extent and location of the pipeline problems, which then is used for rehabilitation by the operator and means for regular examination to maintain a pipeline in good condition. In this paper we shall mainly focus on this type of pigging together with existing technologies for the case study and design.

ILI technologies include the 2 most preferred methods for detecting and measuring metal loss; *magnetic-flux leakage* (MFL) and the *ultrasonics* (U/S).

1. Magnetic-flux leakage ILI tools – the basic principle of this type of technology is by using a sensor to record variations or leakages of the flux path as the pig travels through the steel pipeline. A permanent magnet with two poles is fitted on the pig such that its magnetic field is induced in the pipeline wall and a flux path recorded. The sensor is then placed between the two poles and detect leakages which are directly related to the wall thickness i.e. areas of metal loss. Sufficient flux density is required to be induced in the pipeline wall meaning very powerful and often large magnets are used, this limits the use of MFL tools to thin walled pipelines i.e. in gas pipelines.
2. Ultrasonics ILI tools – its operation principle is basically the measurement of the time taken by an echo to travel to and fro through the pipeline wall, which is directly related to the wall thickness. A transducer is used to emit a pulse of ultrasonic sound which travels at a known speed through the pipeline. U/S tools have a limitation that

is opposite to that of MFL tools as they have a minimum thickness for accurate recordings hence they mainly apply ultrasonic technology in liquid pipelines.

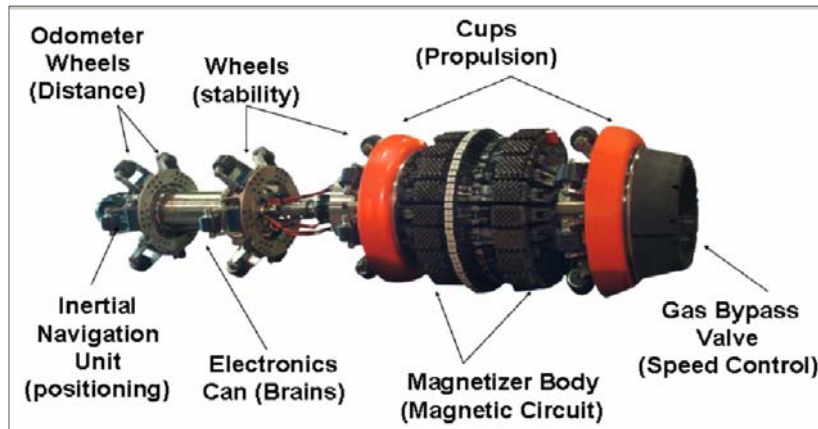

Figure 3. Intelligent pig using MFL technology

Gel pigs

These are basically a series of gelled liquid systems, developed to be used in pipeline operations as mechanical pigs. The gel pigs can either work in conjunction with the mechanical pigs for better performance or can be pumped into any pipeline capable of accepting liquids. There are 3 main types of gel pigs;

1. High-viscosity sealing gels – these are visco-elastic and self-healing gels designed for downhole fracturing techniques with strong cohesive attraction, and used mainly in situations where contamination of the product or pipeline wall is not important.
2. Commissioning cleaning gel systems – these gels have a high yield strength, visco-elastic and plastic flow properties which ensures that the debris remains suspended even if the gel is static for long periods. Cleaning gel pigs are prepared from fresh water or sea water gelled with a biodegradable polymer.
3. Hydrocarbon gels – They are used in operational oil or gas pipelines where aqueous systems are unacceptable, either with a mechanical pig or run alone. Gelled hydrocarbons can be mixed as base fluid, giving the high sealing efficiency characteristic of gel pigs.

Launching

The following procedure to be described is a general guide to pipeline pigging as they vary depending on the pipeline setup as well as the operation procedures. In some cases or companies, the pig launcher might be left on stream and in some, it is isolated after the pig has been run.

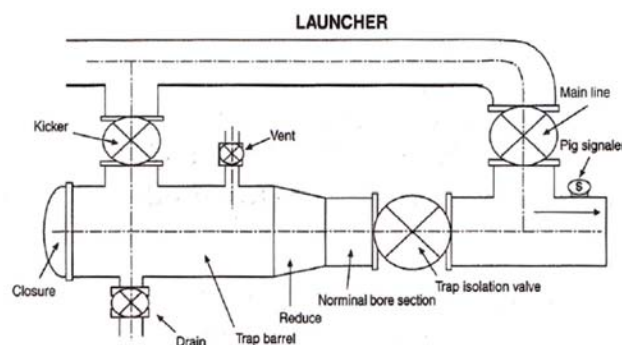

Figure 4. Typical pig launcher

The launcher setup has 3 major valves; kicker valve, trap isolation valve and the main line valve. The other 2 valves, the drain and the vent are fitted on the trap barrel for emptying and pressure balance respectively. The sequence for liquid systems is described as follows;

1. The isolation valve and the kicker valve are closed.
2. The drain valve is opened and air allowed to displace the liquid by opening the vent valve.
3. When the pig launcher is completely drained (0 Pa), with the vent and drain valves still open, the trap (closure) door is opened.
4. The pig is installed with the nose firmly in contact with the reducer between the barrel and the nominal bore section of the launcher.
5. The closure seal and other sealing surfaces are cleaned, lubricated if necessary, and the closure door closed and secured.
6. The drain valve is then closed. By gradually opening the kicker valve and venting through the vent valve, the trap is slowly filled.
7. When filling is complete, the vent valve is closed to allow pressure to equalize across the isolation valve.
8. The isolation valve is opened as the pig is ready for launching.
9. The main line valve is partially closed, thus increasing the flow through the kicker valve and behind the pig. Continue to close the main line valve until the pig leaves the trap into the main line as indicated by the pig signaler.
10. After the pig leaves the trap and enters the main line, the main line valve is fully opened and both the isolation valve and the kicker valve closed.
11. The pig launching is complete.

Receiving

Again the pig receiver, just like the launcher might either be left on stream or isolated as according to the company policies and operation procedures.

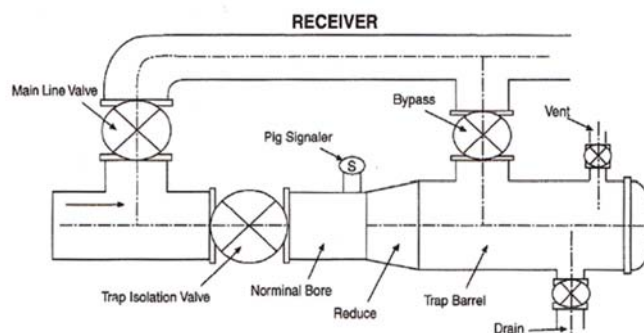

Figure 5. Typical pig receiver

In this case, the kicker valve is replaced by the bypass valve and the rest of the setup remains unchanged except the procedure is reverse as compared to the launching.

3. Methodology

To summarize the methodology, the 1st step will be data compilation as the pigging procedure involves, the study of the pipeline to be pigged by critical qualitative analysis prior to design. Once this information about the pipeline is obtained, a field survey is carried out for the launching and retrieval setup sites along the pipeline, thus the quantitative data. Data sheets and schematic drawings of the pipeline are then produced and the pig designed based on this information. The pig design involves prototype drawing and testing using CAD, thus theoretical calculations produced need to be compared with those produced by the computer so as to optimize and size a final solution which will be the last step in the design procedure.

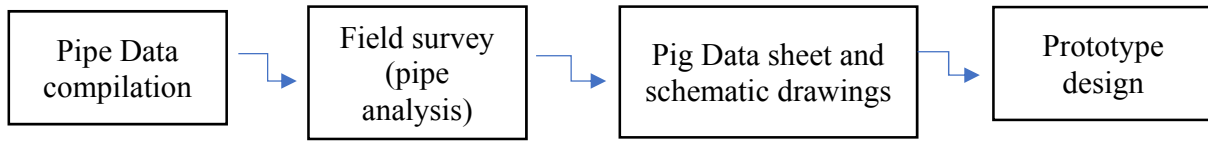

Figure 6. Process flow

The data sheet compiled below is a result of the qualitative collection of pipe information gathered during the visit to the 2 depots under the study. The information contained will be used for calculations and prototype design of chapter 6 and it is specifically for the section of the pipeline to be monitored and cleaned.

Table 1. Pipe Input Data

PARAMETERS	VALUE
Flow-rate(s)	Depot 1 – Depot 2 = 300 000 l/hr Depot 2 – Depot 1 = 150 000 l/hr
Length of pipeline, L	3200 m
Outside diameter, D	300 mm
Thickness, t	5 mm
Pipe depth from the ground	Average of 3 m
Pipe bends	5D bends
Pipe valves	none
Interior condition	smooth
Pipe material	Carbon steel
System pressure, P	60 bars

4. Results and discussion

4.1 Design

NDT technology is currently being utilized in the Pipeline industry through the use of electronic surveying robots commonly known as intelligent or smart pigs. These metal loss or corrosion detecting techniques through long distance pipelines has been made possible due to advances in microprocessor technology. In this section, a detailed design of an intelligent pig which utilizes ultrasonic technology will be designed, based on the 12 inch pipelines which transfer petroleum products between two depots. The PIG will not only perform metal loss detection, but also clean the pipelines as defined by the project aims and objectives. This means the design will be carried out in 2 steps, firstly the mechanical aspect i.e. the pig components sizing and retrofit and then the ultrasonic transducers selected and installed on the pig designed.

Custom sizes and thicknesses in inches and pounds for pig components are tabulated below;

Table 2. Components custom sizes

Pipe Size	Type	A	B	C	Approx. Weight
		OD	Thickness	Center Hole	
	Guide disc	12.0’’	1.0’’	1 1/16’’	5.0 lbs

12''	Sealing disc	12 3/4''	5/8''	1 1/16''	3.5 lbs
	Spacer disc	7.0''	5/8''	1 1/16''	1.4 lbs
	Brushes	12 3/4''	1.0''	1 1/16''	5.0 lbs

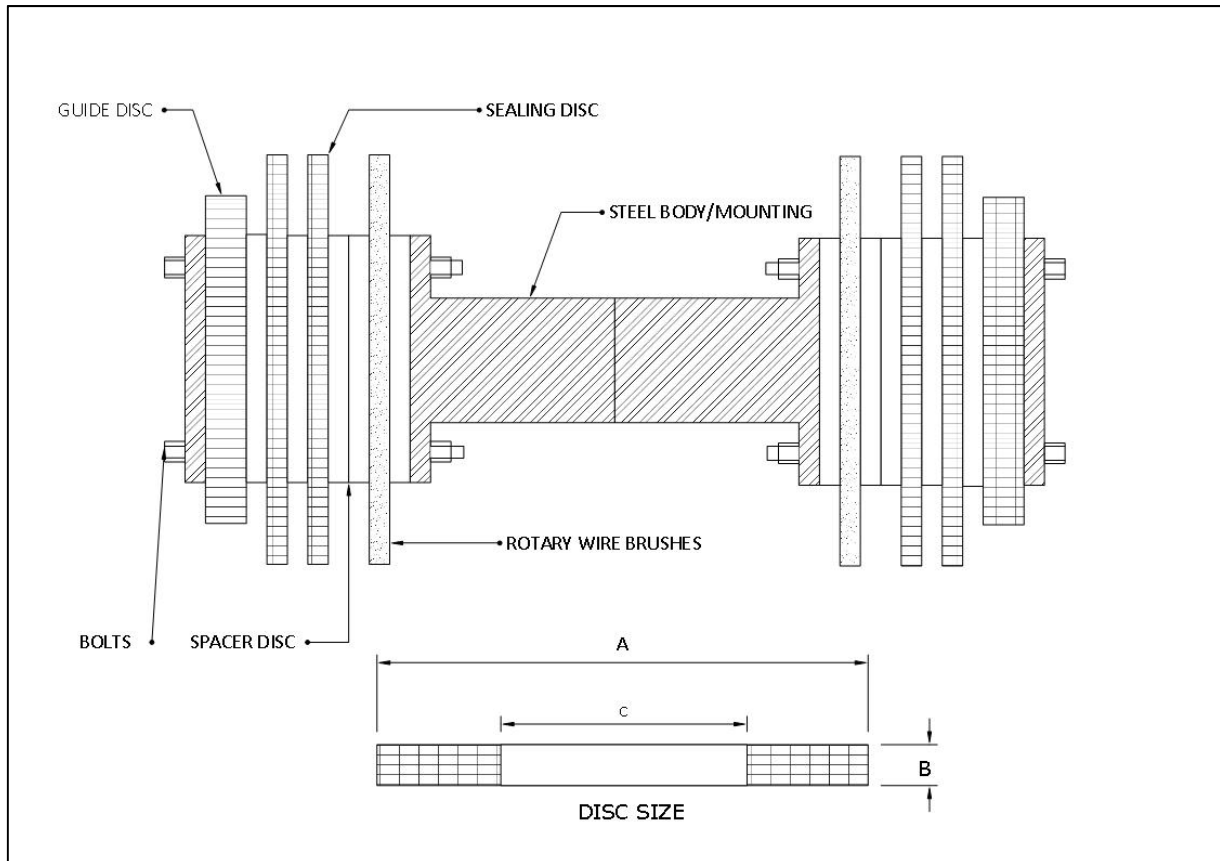

Figure 7. Pig design model (not up to scale) in relation to table 2

Bolt sizes are 12 mm to 14 mm and the pitch circle diameter for the bolt is 145 mm according to the manufacturer standards. For bi-directional pigs, the pig can be launched or propelled in either direction inside the pipe hence, one side is a mirror image of another. This means that the pig design will contain on each side; 1 guide disc, 2 sealing discs, 6 spacer disc c and 1 rotary wire brush.

4.2 Pig motion analysis

Behavior of the bidirectional pig model in steady state motion is analyzed. The working assumptions are listed as following;

- i. Most friction is due to the sliding contact of the seals and the pipe wall, as most of the pig weight is directed to the seal discs (only true for new pigs when wear is negligible).
- ii. The analysis is treated as an axi-symmetrical problem i.e., centerline of the pig matches that of the pipeline resulting in uniform distribution of wear, leakage and friction around the seal circumference (in reality weight causes friction to be greater at the bottom).
- iii. The pressure drop across the bi-di pig is assumed constant and that pressure drop across seals is equal.

- iv. The wall force is assumed to be related to real oversize of the sealing and not guide discs as their design offers zero or little resistance to the flow.

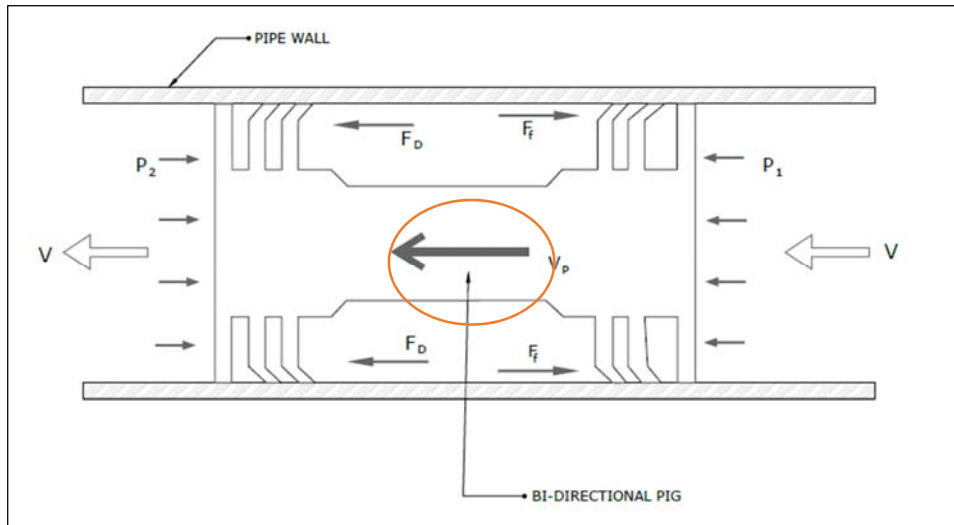

Figure 7. Pig Motion Analysis

It should be noted that the sealing discs are oversized hence when the pig is moving inside the pipeline, they will bend in contact with the pipe wall as indicated by a circle. Flow-rates show that, when fuel is being transferred, due to gravitational aid, the flow-rate is greater than the opposite hence for our design, a greater value mean flow will be used for safety. Also greater values of density will be considered for the design i.e. density of diesel at 20° as given by the company Gasoil specification sheet of October 2015.

Q will be taken as 300 000 l/hr \approx 0.083333 m³/s, Density of diesel; $\rho = 0.8656$ kg/l \approx 865.6 kg/m³, Internal diameter of pipeline; $d = 295$ mm = 0.295m; Contact friction coefficient between polyurethane seals and a steel pipeline is given by; $\eta = 0.6$. Leakage flow for pigs is found to be greater than 0.95, hence for this design; $k_d = 0.98$ will be selected.

Using above figures for pig motion analysis, magnitude of forces, velocities and differential pressure can be calculated as follows;

Drag coefficient of the pig, C_D

$$\begin{aligned} \text{Using the Kogusi equation; } C_D &= 4(k_d)^4 / (1 - k_d^2)^2 &= 4 \times (0.98)^4 / (1 - 0.98^2)^2 \\ &= 2352.739924 &= \mathbf{2353} \end{aligned}$$

Cross-sectional area of the pipe, A

$$\begin{aligned} \text{Using the internal diameter; } A &= \pi \times \left(\frac{d}{2}\right)^2 &= \pi \times (0.1475)^2 \\ &= 0.068349 &= \mathbf{0.0684m^2} \end{aligned}$$

With the drag coefficient of the pig and the cross-sectional area of the pipe both having been determined, the drag force, F_D on the pig created by the flow can now be calculated.

$$\text{Drag force on the pig, } F_D = A \times C_D = 0.0684 \times 2353 = 160.8258 = \mathbf{161N}$$

During steady state motion, the drag force as calculated above is equal in magnitude but opposite direction to the contact friction force, F_f .

Contact friction force, $F_f = \eta \times N = 161$, $N = 161 / 0.6 = 268.0431 = \underline{268N}$

Where, **N is the total normal force that the pig exerts on the pipe wall** in the radial direction and can be considered as the weight of the pig. Using this result, the mass of the pig can then be calculated as follows; $N = mg$, $m = 268 / 9.81, = 27.3235, = \underline{27.32kg}$

Inside the pipe line, the pig moves with a constant velocity, V_p which is less than the mean flow, V due to existence of contact friction as observed from the above calculations. The difference between these two velocities is equal to an amount V_d i.e. $V_p = V - V_d$.

$$V_d = \sqrt{\frac{2\eta N}{Cd\rho A}} = \sqrt{\frac{2 \times 0.6 \times 268}{2353 \times 865.6 \times 0.0683}} = 0.048081 = \underline{0.0481 \text{ m/s}}$$

Since the mean flow-rate is $0.0833 \text{ m}^3/\text{s}$ the corresponding mean velocity, $V = 1.219 \text{ m/s}$. using the above result for V_d , the pig velocity can then be calculated.

Pig velocity in the pipeline, $V_p = V - V_d = 1.219 - 0.0481 = 1.170918 = \underline{1.171 \text{ m/s}}$

Pressure difference across the pig can then be calculated, having obtained the velocity of the pig as well as the drag coefficient.

Pressure difference across the pig, ΔP

$$\Delta P = (C_D \times \rho \times V_d^2) / 2 = (2353 \times 865.6 \times 0.0481^2) / 2 = 2352.7399 = \underline{2353 \text{ N/m}^2}$$

Compiling all calculations and tabulating them to form a design specification sheet.

Table 3. Technical Data Sheet

PARAMETERS	VALUE
Guide disc x2	D = 305 mm (t = 25.4 mm)
Sealing disc x4	D = 324 mm (t = 16 mm)
Spacer disc x12	D = 178 mm (t = 16 mm)
Brushes x2	D = 324 mm (t = 25.4 mm)
Mounting/Pig body diameter	110 mm
By-pass nose diameter	66 mm
Mass (weight) of pig, m	27.32 kg (268N)
Overall length of pig, L	800 mm
Length of pig body	400 mm
Pig velocity, V_p	1.711 m/s
Pig differential pressure, ΔP	2353 N/mm ²
By-pass %	5%
Leakage flow-rate	3.94%

4.3 Design of the ultrasonic pig

This part of the design focuses on utilizing UT technology for metal loss detection. The sensors to be selected in the following section will be installed on the cleaning pig body already designed. After this selection is complete, the two pigs will then be joined together using the universal coupling to form one intelligent and multitasking pig. This

will mean the dimensions of the UT pig and the cleaning pig will be the same, only component arrangement and selection will be rearranged, thus behavior in the pipeline will be identical.

4.3.1 Sensor probe selection

The ultrasonic transducer to be selected should satisfy the following standard operations for a 12 inch liquid pipeline;

- Transducer frequency = 3.5 MHz
- Transducer focus = 165 mm
- Minimum measurable thickness = 3 mm
- Maximum measurable thickness = >1 m
- Inspection sensitivity = ± 0.1 mm

Performance requirements for the transducer are as follows;

- Inspection capacity = 10 hours
- Axial sampling distance = 2 mm
- General metal loss depth at POD of 90% = 0.1 mm
- Depth sizing accuracy at 80% certainty = ± 0.2 mm
- Width sizing accuracy at 80% certainty = ± 0.2 mm
- Length sizing accuracy at 80% certainty = ± 0.2 mm

From the local Zimbabwean market, the transducer that best suit the above requirements is found to be UM30 Ultrasonic Transducer. Since the transducer focus is 165 mm, arranging 4 of them in a circular manner on the pig body will provide a wider and more accurate setup. Battery selection is dependent on the selected sensor as well as the inspection capacity. Since the pig travels at a constant speed of 1.171 m/s, this means it will take approximately 2733 seconds to move inside the pipe from point of launch X to retrieval Y identified as possible launch and retrieval sites. A rechargeable battery which lasts for more than 10 hours with a supply voltage enough to power both the sensor and data recording equipment will be the best recommendation. These are available and purchased together with the UM30 UT selected above.

5. Recommendations and conclusions.

A number of improvements can be made on this device, hence the recommendations will fall into 4 categories;

- Improvements on the Ultrasonic pig

The model designed in this document needs further improvements such as addition of the odometers for online tracking in the pipeline as this will make it easier to track the pig in the event of failure. For future work this automation aspect will be very necessary and economic, hence need to be looked at.

- Further research on the seal deformation and its calculations

The sliding contact analysis is a very important aspect of the design as the rubber seals are the ones which provide significant direct contact between the pipe and the pig, hence it has to be very accurate. More research using FEA has to be done and calculations on the pig motion improved.

- Modelling and testing a physical prototype

Having acquired necessary information through simulations and calculations, a need for a workshop made prototype is needed so as to run physical tests and results observed before the final product to be used by the company is manufactured. This will help identify more loop holes prone to making the pig fail, hence improving the design project.

- Design the launch and retrieval stations

Further research or even a separate design project on the launch and retrieval stations would be necessary requirement for the completion of this work. The company should take this as final piece to add on the work done in this project since the only way to access the pipeline for a successful pigging maintenance is through these 2 stations.

5.3 Conclusion.

The use of pipeline pigging as a maintenance tool serves a great purpose in increasing the life span of the highly pressurized pipelines as well as saving costs and maintenance time. The design of such a device when implemented will help in meeting the demands for an efficient production as the fuel uses in the country keeps on increasing.

Acknowledgements

I would like to thank the company that I worked with for data gathering.

References

- A. Barbian, M. Beller, S. Hartmann, U. Schneider, 2011. High Resolution Ultrasonic In-Line Inspection: Added Value and Special Applications. *Pipeline Technology Conference*, I(6), p. 15.
- Ali M. Sadeghioon, Nicole Metje, David N. Chapman and Carl J. Anthony, 2014. SmartPipes: Smart Wireless Sensor Networks for Leak Detection in Water Pipelines. *Journal of Sensor and Actuator Networks*, I(1), p. 15.
- Alyeska Pipeline, 2016. *Alyeska Pipeline*. [Online]
Available at: <http://www.alyeska-pipe.com>
[Accessed 13 October 2015].
- Antaki, G. A., 2003. *Piping and Pipeline Engineering*. 1st ed. Aiken, South Carolina: Marcel Dekker, Inc.
- BLUCK, M., 2013. How to develop and deliver thick wall multi-diameter offshore inspection solutions: A case study. *Technology Insights*, I(1), p. 7.
- Brossia, S., 2012. *PIG MOUNTED TRIALS FOR INTERNAL CORROSION MONITORING FLUIDIZED SENSORS*, DET NORSE VERITAS: MATERIALS AND CORROSION TECHNOLOGY CENTER.
- Camp, H.-J. d. I., 2010. High Precision With Ultrasonic Pigging. *Pipeline and Gas Journal*, 237(8), p. 10.
- Circor Energy, 2016. *Circor Energy Pipeline Engineering*. [Online]
Available at: <http://www.circorenergy.com>
[Accessed 28 April 2016].
- Dacon Inspection Services, 2016. *Dacon Inspection Services*. [Online]
Available at: <http://www.dacon-inspection.com/resources/downloads/>
[Accessed 06 May 2016].
- Dawson, K., 2008. Factors Affecting the Design and Selection of Pigging Tools For Multi-diameter Pipelines - Multi-diameter Pigging. *Pipeline Engineering*, p. 10.
- Eric Quick, Martin Bluck, Justin Pearce, Jeff Sutherland, Andrew Bain, 2009. Specifications and Requirements for Intelligent pig Inspection of Pipelines. *Pipeline Operators Forum*, p. 38.
- Halima Hadžiahmetović, Ejub Džaferović, 2010. PIGGING SYSTEM. *Trends in the Development of Machinery and Associated Technology*, 11-18 September, p. 4.
- Hashem, D. A.-A., n.d. Oil and Gas Pipeline Design, Maintenance and Repair. *Instrumentation and Pigging*, Volume 7, p. 60.
- HEARN, E. J., 2000. *MECHANICS OF MATERIALS I*. 3rd ed. Oxford: BUTTERWORTH-HEINEMANN.
- Liu, H., 2005. PIG MOTION ANALYSIS. In: T. & F. e-Library, ed. *Pipeline Engineering*. Florida: LEWIS PUBLISHERS, pp. 313 - 315.
- Nagaraj, J., 7-9 July 2015. Smart pigging in high pressure gas pipeline practical problems and solutions- a case study. *3rd International Symposium on Energy Challenges and Mechanics - towards a big picture*, 1(1), p. 1.
- NDT Resource Center, 2016. *NDT Resource Center*. [Online]
Available at: <https://www.nde->

Proceedings of the 2016 International Conference on Industrial Engineering and Operations Management Detroit, Michigan, USA, September 23-25, 2016

O'Donoghue, A. F., 1996. On The Steady State Motion of Conventional Pipeline Pigs Using Incompressible Drive Media. *PHD THESIS*, I(1), p. 247.

Peter Holstein, Hans-Joachim Münch, Santer zur Horst-Meyer, 2010. ULTRASONIC PIG DETECTION AT PIPELINES. I(1), p. 12.

Pigging Products and Services Association, 2016. *Pigging Products and Services Association*. [Online] Available at: <http://www.ppsa-online.com/> [Accessed 06 May 2016].

Pirtle, L., 2013. An Update of ILI Tools & Other Industry Technologies For the Oklahoma Gas Association. *Pipeline Performance*, 1(1), p. 69.

Pople, D. A., 2003. Magnetic Flux Leakage Pigs or Ultrasonic Pigs? The Case for Combined Intelligent Pig Inspections. *6th International Conference, Pipeline Rehabilitation and Maintenance*, 6-10 October, Issue 6, p. 13.

R.S KHURMI, J.K GUPTA, 2005. *A TEXTBOOK OF MACHINE DESIGN*. 1 ed. NEW DELHI: EURASIA PUBLISHING HOUSE (PVT.) LTD..

Ranjbar, M. J., 2015. Pig Running. *Advanced Corrosion, Course Presentation*, 1(1), p. 18.

Sasidharan Adiyodi Kenoth, Ali Al Matar, D. K. Gupta, 2015. Effectiveness of Bypass-Pigging Solutions in Multiphase-Flow Pipelines With Waxy Crude Oil: Evaluation and Innovative Solution. *Oil and Gas Facilities*, I(1), p. 15.

Silowash, B., 2010. *Piping Systems Manual*. New York: The McGraw-Hill Companies.

T.C. Pharris and R.L. Kolpa, 2007. *Overview of the Design, Construction, and Operation of Interstate Liquid Petroleum Pipelines*, Chicago: Argonne National Laboratory.

Tan Tien Nguyeo, Sang Bong Kim, Hui Ryong Yoo, Yong Woo Rho, 2001. Modeling and Simulation for PIG with Bypass Flow Control in Natural Gas Pipeline. *KSME International Journal*, 15(9), p. 9.

Tiratsoo, J., 1992. *Pipeline Pigging Technology*. 2nd ed. Houston, TX: Gulf Professional Publishing.

Varghese, C., 2011. Intelligent pig technology for inline inspection of pipelines and indigenous capabilities development. *IndianOil Corporation Limited*, 1(1), p. 37.

Winters, B., 2016. Cleaning Pig Designs and Applications. *Nace Central Area Conference*, Volume 1, p. 24.

Yan Shi, Chao Zhang, Rui Li, Maolin Cai and Guanwei Jia , 2015. Theory and Application of Magnetic Flux Leakage Pipeline Detection. *Sensors*, 10 December.

Biography

Tawanda Mushiri is a PhD student at the University of Johannesburg in the field of fuzzy logic systems and maintenance, is a Lecturer at the University of Zimbabwe teaching Machine Dynamics, Solid Mechanics and Machine Design. His research activities and interests are in Artificial intelligence, Automation, Design and Maintenance engineering Contacted at tawanda.mushiri@gmail.com / tawandamushiri123@hotmail.com

Stephen Ndlovu is a Mechanical Engineering student at the University of Zimbabwe (2016). Contacted at ndlovustephenm@gmail.com

Charles Mbohwa is currently a Full Professor of Sustainability Engineering and Engineering Management at the University of Johannesburg, South Africa. Contacted at cmbohwa@uj.ac.za