

SME Competitiveness through Online Brand Communities: an Exploration of Brand Loyalty

Mojtaba Poor Rezaei, PhD Student, University of Salford

Room 926 – Maxwell Building – University of Salford – M5 4WT – T: 0161 29 55024 – e:
s.m.poorrezaei@edu.salford.ac.uk

Dr. Aleksej Heinze, Senior Lecturer, University of Salford

Keywords: SME competitiveness, Consumer engagement, brand loyalty, social influence theory, online brand community, Elaboration Likelihood Model

Objectives

This paper examines one aspect of online brand communities - that of brand loyalty. In particular, it explores how the online strategies of Small and Medium Sized Enterprise's (SME) could be operationalised. The paper aims to address the need for further empirical research into consumer behaviour in online brand communities, as suggested by De Valck et al. (2009), Brodie et al. (2013) and Wirtz et al. (2013).

Prior work

SMEs are the largest type of company under-utilising online brand communities on social media (Aaltonen et al., 2013). A number of them see social media as a major challenge and many simply do not recognise the value in developing social media based brand communities (Heinze et al. 2013).

Approach

In this study, an online survey of 110 participants is used to explore their behaviour in online brand communities and to identify drivers for consumer engagement as well as the effects of consumer engagement strategies on brand loyalty. The data was analysed using the Structural Equation Model (SEM). The elements of the proposed model are based on an in-depth literature review of social influence theory and online consumer behaviour. The primary data collection is achieved using Amazon Mechanical Turk surveying members of online brand communities across different product categories.

Results

This work recommends that in order to positively influence online brand loyalty, an organisation has to focus on a) information quality b) social influence theory variables and c) customer engagement. It also highlights the increasing importance of relationship marketing for SMEs in an online environment.

Implications

For practitioners, the findings suggest that when small firms are considering developing their social media strategy, they need to address the following issues: a) **quality of information** shared in online brand communities; b) **"closeness" of online brand community members** and c) their **sustainable long term community engagement strategy**.

Value

This paper's findings indicate the importance of understanding how customers engage in online brand communities. As a consequence of engagement the paper highlights increasing brand loyalty. This study also proposes and tests a theoretical model for future studies in this area.

SME Competitiveness through Online Brand Communities: an Exploration of Brand Loyalty

Objectives

This paper examines one aspect of online brand communities - that of brand loyalty. In particular, it explores how the online strategies of Small and Medium Sized Enterprise's (SME) could be operationalised. The paper aims to address the need for further empirical research into consumer behaviour in online brand communities, as suggested by De Valck et al. (2009), Brodie et al. (2013) and Wirtz et al. (2013).

Prior work

SMEs are the largest type of company under-utilising online brand communities on social media (Aaltonen et al., 2013). A number of them see social media as a major challenge and many simply do not recognise the value in developing social media based brand communities (Heinze et al. 2013).

Approach

In this study, an online survey of 110 participants is used to explore their behaviour in online brand communities and to identify drivers for consumer engagement as well as the effects of consumer engagement strategies on brand loyalty. The data was analysed using the Structural Equation Model (SEM). The elements of the proposed model are based on an in-depth literature review of social influence theory and online consumer behaviour. The primary data collection is achieved using Amazon Mechanical Turk surveying members of online brand communities across different product categories.

Results

This work recommends that in order to positively influence online brand loyalty, an organisation has to focus on a) information quality b) social influence theory variables and c) customer engagement. It also highlights the increasing importance of relationship marketing for SMEs in an online environment.

Implications

For practitioners, the findings suggest that when small firms are considering developing their social media strategy, they need to address the following issues: a) **quality of information** shared in online brand communities; b) **"closeness" of online brand community members** and c) their **sustainable long term community engagement strategy**.

Value

This paper's findings indicate the importance of understanding how customers engage in online brand communities. As a consequence of engagement the paper highlights increasing brand loyalty. This study also proposes and tests a theoretical model for future studies in this area.

Introduction

The challenge of not knowing how best to engage or interact on social media is one of the reasons SMEs ignore it. However, by not engaging with online brand communities a business is gambling with its reputation and does not benefit from the positive views of loyal brand advocates which could be amplified if a business were aware of them. Brand loyalty is used in this study to refer to the repeat custom of consumers who on a regular basis patronise a certain brand. The customer lifetime value varies according to industry, but even those businesses that rely on a single transaction can capitalise on positive reviews from their customers who are essentially their brand advocates.

Engagement on social media for a small and medium sized enterprise (SME) is becoming paramount for business survival (Michaelidou 2011) and growth (Aaltonen et al 2013). Social media channels offer a place for developing online brand communities, which in turn provide a space for companies and customers to interact and learn from one another. However, companies that do not engage in these online brand communities risk their customers taking charge and shaping opinions about the company that may not always be favourable (Hackett, 2012).

In their basic form online brand communities are places that facilitate communication between individuals who have an association with a certain organisation or its product or service. A small coffee shop can have a Facebook page where it posts regular updates on its offerings, a florist can notify its community members about the latest flowers it has in store, recent wedding flowers or arrangements it has created. Keeping in close contact with those interested in hearing about a particular business and sharing news and feedback about the latest developments offers an on-going dialogue between a brand and its customers.

Online brand communities in their basic form can be hosted on an existing social network such as a Facebook group, LinkedIn group or by Twitter hash tag. Organisations that do take charge of online brand communities develop their sophisticated brand name related blogging platforms or discussion forums, which are integrated into the overall marketing communications mix.

The skill of planning a strategy for an online brand community, developing an engagement plan and operationalizing these communities is a challenge faced by many businesses. This is not made easy with the constant stream of new social networks and technological advances which facilitate yet another set of challenges. For example, it is not always clear which networks should be used to engage with customers and how a business should behave on these communities as well as how to adapt to the fickle nature of the internet where one platform's preference is often replaced by another.

On the other hand, we know that it is the customers and IT suppliers who are considered to be the main drivers for the adoption of The Internet technologies by small firms, not the competition or government policy Beckinsale (2006). It is therefore these loyal brand advocates that we need to identify and engage with in the most effective way in order to sustain online brand communities. Therefore, the aim of this paper is to explore brand loyalty as a consequence of online brand community engagement. This is followed up by a description of the data collection method and a discussion of results and recommendations.

By understanding how best to engage with loyal brand customers we are able to develop a long term social media strategy for an SME. The paper is structured as follows: First of all we examine the existing studies looking at consumer engagement in online communities, we then examine the consequences of consumer engagement in an online brand community by building a model to study engagement.

Consumer engagement in an online community

There is no agreement amongst researchers on a definition of the concept of engagement in an online brand community. In this section the different uses of this notion are compared and then the working definition of this paper is presented.

It is important to highlight the different terms that are interchangeably used in order to clarify what we mean by "consumer engagement". The terms "involvement", "participation" and "interaction" are similar words to "engagement" and have been used in marketing literature to address the same concept although these are not completely the same in meaning. Dholakia et al. (2004) define "participation" in a virtual community as a product of the frequency and duration of community visits while "engagement" extends beyond mere participation. The difference between "involvement" and "engagement" is highlighted in the study of Mollen

and Wilson (2010). They suggest that “engagement” involves instrumental value and also the individual’s perceived experiential value that is obtained from interaction with a specific brand. Consequently, the authors define a consumer’s brand engagement as

“a cognitive and affective commitment to an active relationship with the brand as personified by the website or other computer-mediated entities design to communicate brand value” (Mollen and Wilson, 2010: P.152).

The other term “interaction” is discussed in the studies of Hollebeek (2011) and Kuo and Feng (2013). The authors scrutinise how the concept of “engagement” differs from “interaction”. Hollebeek (2011) cites that “engagement” encompasses the levels of cognitive and emotional rather than merely behavioural activity in a brand community. So, Hollebeek (2011) defines “consumer brand engagement” as

“the level of a consumer’s motivational, brand-related and context-dependent state of mind characterised by specific levels of cognitive, emotional and behavioural activity in brand interactions” (Hollebeek, 2011: P.24).

A working Definition

This paper adopts a working definition of “engagement” by Brodie et al. (2013). They suggest:

“Consumer engagement in a virtual brand community involves specific interactive experiences between consumers and the brand, and/or other members of the community. Consumer engagement is a context dependent, psychological state characterised by fluctuating intensity levels that occur within dynamic, iterative engagement processes. Consumer engagement is a multidimensional concept comprising cognitive, emotional, and/or behavioural dimensions, and plays a central role in the process of relational exchange where other relational concepts are engagement antecedents and/or consequences in iterative engagement process within the brand community” (Brodie, 2013: P.108).

There are three main reasons to adopt this working definition. Firstly, the definition matches with the other definitions by Van Doorn et al. (2010), Hollebeek (2011), Mollen and Wilson (2010) and De Valck et al. (2009). Secondly, the definition investigates the consumer engagement in the online brand community, which is directly related to the research setting of this paper. This definition shows the importance of consumer engagement in a virtual brand community and goes beyond the other similar terms. Importantly, the definition provides a good source from which to develop items in order to measure the consumer engagement concept in online brand community that is used in the model of this study.

The approach of this paper to measuring engagement

This paper adopts the dynamic conceptual model of the consumer engagement process in a virtual brand community as proposed by the research of Brodie et al. (2013a). The research has identified that consumer engagement includes five sub-processes Figure 1: learning, sharing, co-developing, advocating, and socialising.

The sub-process of learning “characterises the vicarious acquisition of cognitive competencies that consumer apply to purchase and consumption decision-making” (Brodie et al., 2013a). This step is similar to what De Valck et al. (2009) call “retrieving information” as a form of participation in virtual communities. In this stage, consumers share their questions with others in order to be informed about their issue by other consumers.

The other sub-process of consumer engagement is known as the sharing stage. It includes the “sharing of personal relevant information, knowledge and experiences through the process of active contributions to the co-creation of knowledge within the online community” (Brodie et al., 2013a). The behavioural and cognitive dimension of consumer engagement is reflected in this stage. One similar variable of consumer engagement measurement in the study of De Valck et al. (2009) is “supplying information”.

When consumers actively encourage other members to buy a specific brand and recommend a service or product to them, this is known as the advocating stage. Brodie et al. (2013a) suggest that “advocating is an expression of consumer engagement”.

Socialising is the other sub-process of consumer engagement which is defined by Brodie et al. (2013a) as “two-way, non-functional interaction through which consumers acquire and/or develop attitudes, norms and/or community language”. The other similar variable that De Valck et al. (2009) have mentioned to indicate the total level of engagement is “discussing”.

Finally, co-developing is “a process where consumers contribute to organisations and/or organisational performance by assisting in the development of new products, services, brand or brand meaning” (Brodie et al., 2013a). In the research of Brodie et al. (2013a) on a community involved in “health and fitness”, the author shows how consumers contribute to the development of a new product through the engagement process.

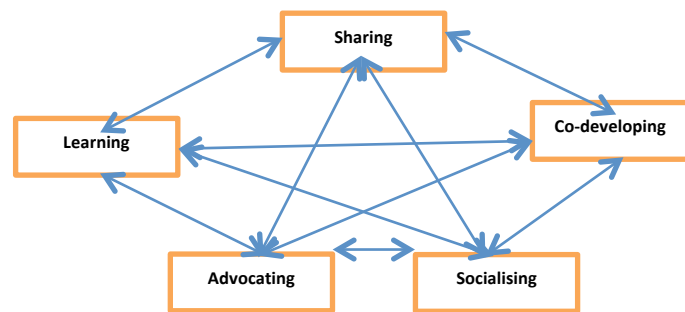

Figure 1 the five sub-process of consumer engagement in online brand community adapted from Brodie et al. (2013)

In order to develop items for measuring consumer engagement, the related items of each sub-process are adopted from the study of Brodie et al. (2013a) and De Valck et al. (2009). By identifying the level of consumers’ activity regarding these measures, the more insight in engagement behaviour in a community is obtained. The adopted items of the construct of consumer engagement are presented in the appendix as well as the other constructs in the model.

Elaboration Likelihood Model (ELM)

Indications of influence and the importance of the influence process in modelling an individual’s attitude and behaviour have been explored by extent dual-process theories in the field of social psychology. One of the best known of such theories regarding social information-processing phenomena is the Elaboration Likelihood Model (ELM). ELM is a theory of persuasion and explains the influence processes, which lead to attitude change. Petty and Wegener (1999) suggest that ELM provides a comprehensive framework for understanding how individuals process information (Jones et al., 2006).

This model posits that two “routes” of influence cause attitude change and consequent behaviour change among individuals. According to this model, there are two distinct routes of persuasion: the Central Route and the Peripheral Route. “Central-route attitude changes are those that are based on relatively extensive and effortful information-processing activity, in contrast peripheral-route attitude changes are based on a variety of attitude change processes that typically require less cognitive effort” (Petty and Wegener, 1999). The influence process happens through central routes when a person examines the issue-relevant considerations thoughtfully. When individuals use some simple decision rule in order to form and change their attitude however, the influence process happens through a peripheral route. For example, in message-based communication, argument quality and source expertise are considered as constructs of central and peripheral route respectively.

Motivation and the ability to think carefully are two main conditions that identify which route the influence process happens through. These conditions will determine how individuals deal with different persuasive appeal. The central route of persuasion occurs when one is highly motivated and involved with the topic of communication and has a high degree of ability to process the argument. However, when one’s information-processing capability and involvement is limited, the peripheral route of persuasion occurs. Factors that influence an individual’s attitude under the peripheral route are called “peripheral cues” and those factors that cause a change in one’s attitude via the central route are called “central cues”.

Proposed model

This paper's conceptual framework (Figure 2) explicates the motivations and consequences of the consumer engagement in an online brand community. The framework draws on marketing studies of OBC, a social influence model of participation and a model of persuasion. Therefore, social influence variables (group norm, community identification and brand identification) and also information quality as the main variables of the ELM are adopted for this study as antecedents in shaping engagement behaviour in online brand community. Therefore, this study adopts the Elaboration Likelihood Model (ELM) of Persuasion as the theoretical model to explain an individual's influence process of engagement in an online brand community and the impact of consumer engagement on brand loyalty.

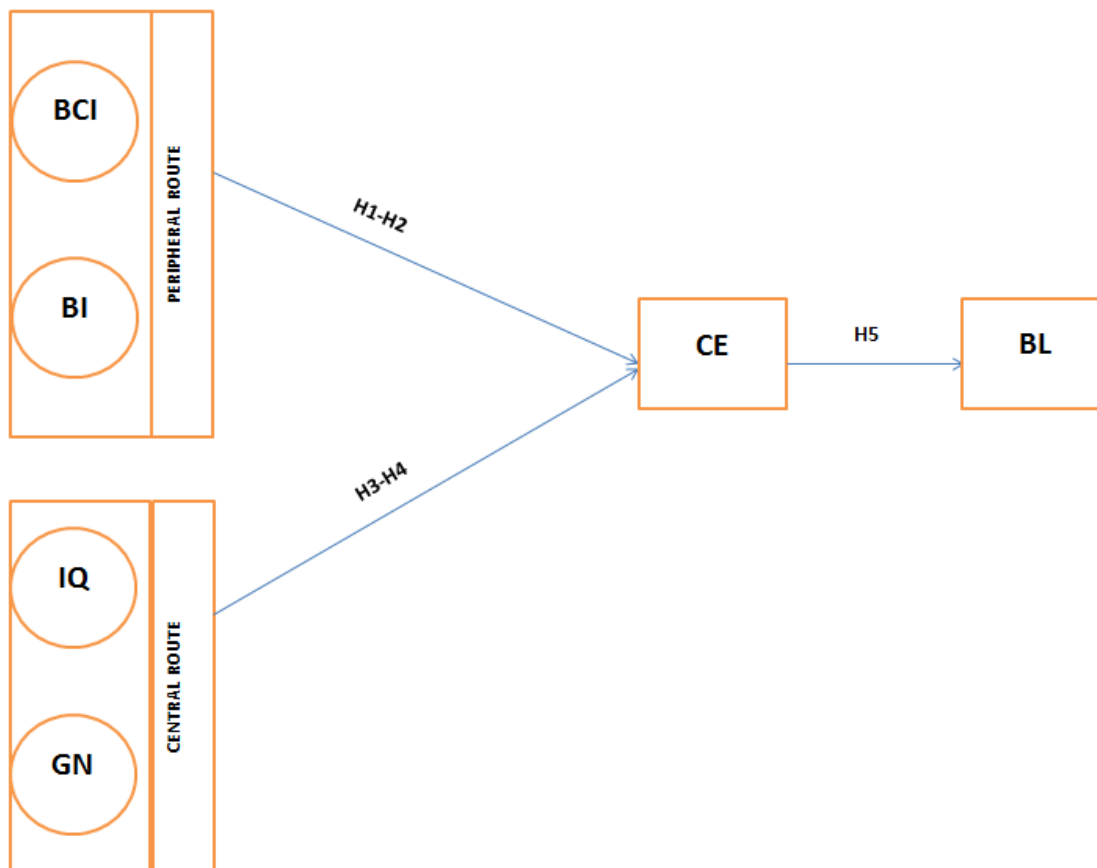

Figure 2 Consumer engagement persuasion process in Online Brand Community. BCI = Brand Community Identification, BI = Brand Identification, IQ = Information Quality, GN = Group Norm, CE = Consumer Engagement, BL = Brand Loyalty

Central Cues

Information Quality. OBC enables communication and interactive learning for consumers. Consumers join an OBC to access high quality of information regarding a brand's products and services. The information provided to the OBC helps consumers during the decision making process. Therefore, the quality of information is important for OBC members and Dholakia et al. (2009) suggest information quality as a key factor and one that consumers define as a perceived benefit. However, Nelson et al. (2005) define the dimensions of information quality as including: Accuracy, completeness, currency and format while Zhou (2012) suggests relevancy and sufficiency instead of completeness and format.

The significant relationship of information quality with initial trust in mobile banking (Zhou, 2012), online shopping (Yang et al., 2006), learning in problem solving virtual communities (Dholakia et al., 2009) and

membership satisfaction in online community (Lin, 2008) are explored. In addition, Wirtz et al. (2013) categorise information quality as a functional driver of consumer engagement in an OBC and Lin (2008) suggests it as a key success of an online community and put it in system characteristics. In addition, Zhou (2012) and Yang et al. (2006) have reported information quality as central cues. Therefore, this paper proposes the following hypothesis:

H1: Higher levels of information quality lead to greater level of engagement regarding the online brand community.

Internalisation. Internalisation is one of the processes of social influence that is operationalized as a group norm. Several studies have investigated the impact of group norms on attitude and behaviour of group members. The research shows that members of a group construct a common behavioural frame or as Knippenberg (2008) s “a shared judgmental frame of reference” that guides members’ behaviour and judgment. Therefore, group norm refers to the commitment of group members to the shared goals and values, which are made known during socialisation with other members of group. Actually, Dholakia et al. (2004) identify other ways than socialisation that group norms may become known to group members. One happens when new members are interested in joining the group and actively seek out the conventions and goals of group. The other possibility is when individuals learn the group goals beforehand and then join the group because they find out that the group values are similar to their own. The purpose of this paper by group norm is what members discover through participation in the community.

As discussed, a group norm affects the attitude and consequent behaviour of group members. Group norms are relevant to online communities and researchers investigate the role of group norms in an online context. The significant relationship of group norms and a desire to participate (Dholakia et al., 2004, Shen et al., 2009) and product-attitude change (Kate, 2010) were studied. Also, group norm influences through the central route as Knippenberg (2008) and Hamilton (1999) suggest that norm-induced influence is based on “the systematic processing of norm-representing communications”. The systematic processing occurs in central route. Therefore, this paper proposes the following hypothesis:

H2: Stronger group norms lead to a greater level of engagement regarding the online brand community.

Peripheral cues

Identification with brand community. Algesheimer et al. (2005) characterize “brand community identification” as being the strength of relationship between consumers and the brand community, whereby individuals construe themselves to be a member of the brand community. This collective identity is what Dholakia et al. (2004) have used in their study to explain the term “belonging” to a community and incorporates ideas from social identity theory. The theory of social identity has been widely used to study the attachment of an individual to a group, organisation and brand. Social identity includes two affective (a sense of attachment and emotional involvement) and cognitive (the sense of self-awareness that individual forms it in community) components. A cognitive component is related to when individuals see similarities with other members of the brand community and non-similarities with those who are not the community members. The affective component has been characterised as “kinship between members” in brand community research (McAlexander and Schouten, 1998).

Some studies conceptualise identification with only one component that is cognitive (Ashforth et al., 2008) while some other studies include an evaluative component (sense of self-worth) as well (Lam et al., 2010, Dholakia et al., 2004). In response to the first group, Epstein (1980) states that “self-related attitude is closely associated with the emotion” and the important aspect of relationship marketing is about emotion (Bagozzi, 1995). However, reviewing the second group of studies shows that they could not find any significant relationship between evaluative and participation in an online community. Therefore, this paper in line with the research by Algesheimer et al. (2005) conceptualises the identification with cognitive and affective components.

There are many positive consequences for a consumer in identifying with a community such as the study of Muniz and O’Guinn (2001) which shows that the members of a Mac community help each other by sharing information about increasing the performance of their computers. Also, according to social influence, an

individual identifies with a group in order to maintain a satisfying self-defining relationship to the other (Shen et al., 2009). Therefore, consumers who are interested in establishing a relationship with other consumers to gain mentioned benefits are more likely to engage in an online brand community.

The significant relationship of brand community identification with the desire for participation (Dholakia et al., 2004) and offline-community engagement (Alghesheimer et al., 2005) are explored. In the terminology of ELM, shared characteristics such as social identity always play the role of peripheral cues (Fleming and Petty, 2008) and this is similar to a study by Hamilton (1999) that considers identification as a peripheral cue. Therefore, this paper proposes the following hypothesis:

H3: A stronger identification with the community leads to higher levels of engagement in the online brand community.

Identification with brand. Similarly to the previous discussion about identification with the community, the other aspect of identification could be with the brand. Lam et al. (2010) define Consumer Brand Identification (CBI) as “a consumer’s psychological state of perceiving, feeling and valuing his or her belongingness with the brand.” Carlson et al. (2008) examine the relationship between brand identification and brand commitment and Lam et al. (2010) explore its association with the resistance to switching to another brand. As explained about the relationship between identification with community and engagement, the following hypothesis is suggested regarding the relationship between identification with the brand and engagement:

H4: A stronger identification with the brand leads to higher levels of engagement in the online brand community.

Consequence of consumer engagement processes

Brand Loyalty. Hollebeek (2011) have found a relationship between brand community engagement and the consumer’s brand-related behaviours such as brand loyalty. It can be explained that if engaging with a community leads to perceived value, consequently consumer satisfaction and loyalty will be increased. The investigation into anonline brand community in the study of Brodie et al. (2013a) shows that consumers express their loyalty to a brand by recommending the preferred brand to others.

In this paper, it is expected that engagement in an online brand community leads to stronger brand loyalty since an important result of membership in a community is continuing purchase and use of the brand (Alghesheimer et al., 2005). Therefore, this paper proposes the following hypothesis:

H5: greater levels of engagement have a positive effect on brand loyalty.

Measures

The multi-item-scales are used to measure the constructs that are adopted from pre-validated measures in prior related studies (see Table 1). All items are modified by the authors for use with online brand community members. A pilot test was conducted to ensure the questions were understandable and easy to follow. The items used for the main study are provided in the Appendix.

Table 1 Measures of constructs in the proposed model

Constructs	Operational Definition	Number of Measures	Source of Measurement Items
Information Quality	The degree to which the provided information is perceived as being accurate, up to date and complete	4	Zhou (2012), Lin (2008) and Dholakia et al. (2009).
Group Norm	The degree to which the value of the group in term of engagement is internalised.	2	Dholakia et al. (2004), Shen et al. (2009) and (Zhou, 2011).
Brand Identification	The degree to which individuals see themselves as being attached to the brand.	5	Bagozzi and Dholakia (2006), Lam et al. (2010), Hughes, Ahearne (2010) and Carlson et al. (2008).
Community Identification	The degree to which individuals see themselves as being attached to the community.	5	Shen et al. (2009), Carlson et al. (2008) and Lam et al. (2010).
Consumer Engagement	The degree to which one engages in community regarding sharing, advocating, co-developing, socialising and learning.	5	De Valck et al. (2009) and Brodie et al. (2013) and the Authors.
Brand Loyalty	The degree to which one tends to continue purchasing the brand and recommends it to others.	4	Hollebeek (2011), Gummerus et al. (2012) and Nam et al. (2011).

Data Collection Method

A questionnaire was designed using the Bristol Online Survey (BOS via the link <http://www.survey.bris.ac.uk>). The features of OBS enable the author to make an easy-to-read, well-structured and clear questionnaire that minimises respondents' confusion. The questionnaire was used to collect data from 110 respondents who are members of different online brand communities. The Amazon Mechanical Turk (AMT) was used as a tool for conducting the online survey.

Amazon Mechanical Turk

Amazon Mechanical Turk could be considered as an online brand community in its own right. Paolacci et al. (2010) describe AMT as "a crowdsourcing web service that co-ordinates the supply and the demand of tasks that require human intelligence to complete" and in particular, "it is an online labour market where employees (called workers) are recruited by employers (called requesters) for the execution of tasks (called HITs, acronym for Human Intelligence Tasks) in exchange for a wage (called a reward)." In AMT, the workers and requesters are both anonymous but each worker has a unique ID that is provided by Amazon. Requesters post the tasks (HIT) and can also define the criteria so that only those workers who can meet them have access to this task. The criteria include country of residence or the degree of accuracy that is based on previous completed tasks. The workers can find these tasks on their own page and they choose tasks based on the criteria and the time needed to complete the task as well as the reward. It is possible for requesters who are not happy with a worker who has done the tasks poorly, to punish them by refusing payment or alternatively to can give a bonus to good workers.

The AMT has three main advantages which is outlined as follows (Mason and Suri, 2012):

Subject pool access: this is one of the main features of AMT and is also the main reason for conducting this study via the AMT. Access to the research objectives, as well as to the large pool of the members of the OBC is needed for conducting the survey and for data collection. The AMT offers such access to “a large, stable pool of people willing to participate” in the questionnaire for relatively low pay (Mason and Suri, 2012).

Subject pool diversity: the other feature of the AMT that makes it a great tool for research is the diversity of subject pool. The workers in the AMT are from a wide range of backgrounds, ethnicities, first languages and etc.

Low cost and built-in payment mechanism: Another advantage of the AMT is about being low cost for conducting a study. Importantly, the built-in payment mechanism rather than a third-party payment mechanism reduces the difficulties for paying workers for their participation in the study.

There is a growing body of research that discusses data quality and validity of conducting studies on AMT. Mason and Suri (2012) highlight the unique advantages of AMT for conducting behavioural research. In addition, Paolacci et al. (2010) suggest that AMT is a powerful tool that should be considered as a viable one for data collection. Importantly, Paolacci et al. (2010) addresses the concerns regarding the validity and generalizability of data collected in their study.

Surveys on Mechanical Turk

Building the online survey on AMT can be done in two ways. First AMT provide a template to help with the construction of surveys. It needs to use standard HTML to put the questions in the template. After completing the questionnaire, AMT record the collected data from workers and the results can be exported in a column-separated file (.csv). The other way is to use an external HIT that means a survey designed by an outside service. Then the link of the survey can be embedded in AMT and can be accessed by the participants. The latter method is used for this study due to its benefits. These benefits include: an “increased control over the content and aesthetics of the survey” (Mason and Suri, 2012). Also, there is more control regarding the structure of survey such as having multiple pages for it. Finally, in this way the data is more secure as it is not stored on AMT. However, conducting the survey on AMT has the same advantages and disadvantages as any online survey.

Data

Of the 120 online brand community members that participated in the questionnaire, a total of 110 completed the survey and their responses were useful for analysis. The demographics of the sample are as follows: There were 65 male (59.1 %) and 45 female (40.9) who participated in the survey. The majority of respondents belonged to the age group of 25-34 (54.5%) followed by the age groups of 18-24 and 35-44 (respectively 21.8% and 18.2%). By education, the most represented education level in the sample was higher education (76%). By duration of membership, 35.5% (n = 39) had belonged to their online brand community between one and three years and 32% (n=29.1) had belonged between 6 months and a year, and 21.8% (n=24) had belonged less than 6 months and 13.6% (n = 15) had belonged more than three years.

Analyses and Results

Reliability. SPSS 20.0 was used to assess the reliability. Table 15 illustrates the result of the internal consistency that is assessed by Cronbach's alpha, which is also known as coefficient alpha. The internal consistency reliability is “the degree to which responses are consistent across the items within a measure” (Netemeyer et al., 2003). The acceptable value for Cronbach's alpha is 0.7 or above (Hair et al., 2010). The reliability coefficients around 0.9 are considered “excellent” and the reliability values around 0.7 are “acceptable” and lower than 0.7 is considered as “poor” coefficient reliability (Kline, 2011). As Table 2 shows, all values indicate acceptable construct reliability.

Table 2 Means, Standard Deviations, Reliability statistics for construct measures

Construct	Mean	Standard Deviation	Cronbach's alpha
Information Quality	5.54	1.13	0.85
Group Norm	5.10	1.18	0.71
Brand Identification	5.18	1.62	0.89
Community Identification	5.02	1.30	0.91
Consumer Engagement	4.85	1.29	0.79
Brand Loyalty	5.30	1.18	0.80

Convergent validity. This study used Exploratory Factor Analysis (EFA) in order to assess the factor loadings of the measurement items of all constructs. The range of factor loadings was from 0.780 to 0.954. As Fornell and Larcker (1981) suggested the measures of AVE (Average Variance Extraction) for convergent validity, this study assessed the AVE which is shown in Table 3. AVE estimates the amount of variance captured by a construct's measure relative to random measurement error (Alegheisheimer and et al. 2005). When the value of AVE is greater than .50 this is considered as acceptable convergent validity. The values are shown in Table 3 and are significantly greater than .50 thus the convergent validity is supported.

Discriminant validity. The Confirmatory Factor Analysis (CFA) model was built by Amos 20.0 with 6 constructs and 25 measures. The statistics of goodness-of-fit (GOF) show that the model fits the data very well. The results are as follows: $\chi^2(260) = 559.957$, Probability Level = .000, RMSEA = .07, CMIN = .2 and CFI = .96. Also, As Table 3 shows, all correlation among the constructs are significantly less than one. It is necessary to assess the square root of correlations between constructs and compare these to the value of AVE. The measurement model achieves discriminant validity when the value of AVE of each construct is greater than squared correlations of the construct and the rest of constructs. As Table 3 shows, all AVE values are greater than the squared inter-constructs correlations. The column labelled AVE is the AVE to the second power in order to compare with other columns that are the correlation between the construct and the rest of constructs. The AVE of each construct is bold in the table.

Table 3 Correlation matrix of latent constructs for full sample and Average Variance Extraction (AVE) for discriminant and convergent validity

	AVE	BI	CI	IQ	CE	GN	BL
BI	0.644	0.803					
CI	0.680	0.456	0.824				
IQ	0.605	0.384	0.545	0.778			
CE	0.655	0.607	0.524	0.442	0.675		
GN	0.608	0.610	0.680	0.458	0.638	0.780	
BL	0.524	0.531	0.615	0.548	0.625	0.343	0.724

Structural Model Estimation

The model fit statistics indicates a good model fit. All statistics are within the acceptable range: $\chi^2(260) = 420.450$, Probability Level = .000, RMSEA = .07, CMIN = .2 and CFI = .92. According to the Structural Equation Modelling (SEM), all hypothetical paths which are shown in Figure 3 are statistically significant. The result shows a strong and positive impact of information quality on consumer engagement ($b = .85$, standard error (s.e.) = .02), therefore H1 is supported. In support of H2, there is a significant and positive impact of group norm on consumer engagement ($b = .32$, s.e. = .21). In addition, as we suggested, the impact of identification with brand on consumer engagement is positive and therefore the H3 is supported ($b = .95$, s.e. = .01). In support of H4, a significant and positive impact of identification with community and consumer engagement is found ($b = 1.21$, s.e. = .02). Finally, the impact of consumer engagement on brand loyalty is

addressed in H5. The result shows that our prediction is supported. Thus, the impact of consumer engagement on brand loyalty is positive and significant ($b = .84$, $s.e. = .03$).

Figure 3 the SEM analysis of proposed model, * $p < .01$, ** $p < .001$

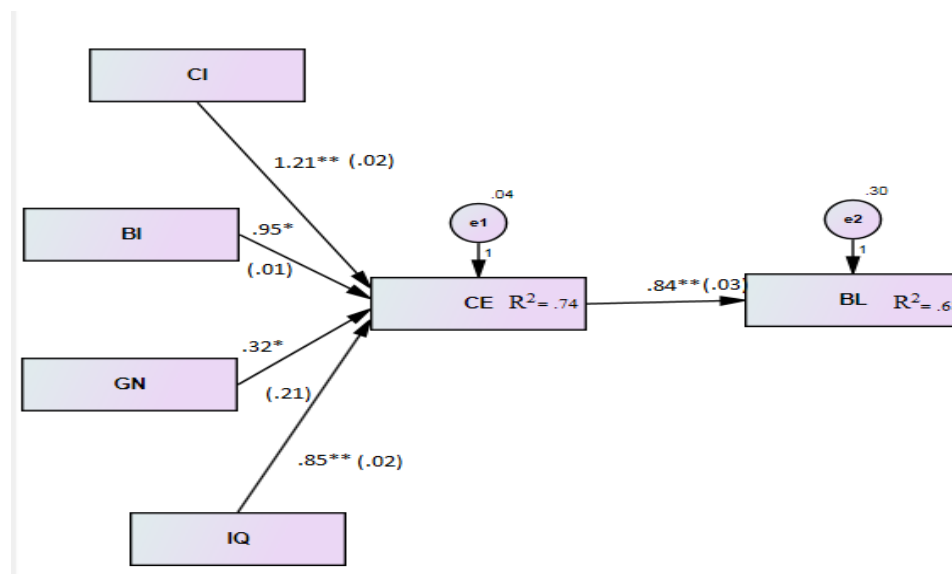

Discussion and Managerial Implications

In the current research, we explored the social influence of online brand communities as well as quality of information on consumer engagement. According to the data analysis, our conceptual model was supported in a rather large sample of different online brand community members. The following are the main findings and recommendations to SMEs who are planning or reviewing their online brand community strategies:

Quality of information

This study emphasizes the importance of managing and controlling interaction among consumers and also providing high quality information that leads to higher consumer engagement. This means that in practical terms an SME with limited resources should focus its attention on the quality of information that it provides to the online brand community. Brand advocates would be more likely to engage with information that discusses an in-depth view of how your product or a service is evolving. Whilst brands have also to entertain community members (Heinze et al 2013), the main emphasis should be placed on producing quality material instead of quantity. For example, tweeting for tweeting's sake or posting messages just to post something is not a useful application of resources.

“Closeness” of online brand community members

In contrast to the quality of the information, the online brand community organisers should consider how the community members could be brought closer to one another. Closeness relies on individuals knowing about each other. Therefore, an online brand community that offers its brand advocate members an opportunity to personalise their profiles and talk about some “off topic” points can have positive value – since it is creating a closeness between members. This study supports earlier work where the idea of social capital accumulation was proposed as a means for development of community structure (Heinze et al 2013).

In practical terms, the ability to bring about closeness of dedicated brand advocate members could be created by bringing these brand advocates together to a face-to-face event. This could be dedicated to the most influential brand advocates who would also be prepared to travel long distances and engage with the brand.

Sustainable long-term community engagement strategy

Developing an online brand community is a resource intensive exercise. Any SME that is relying on a number of individuals to fulfil multiple roles will need to consider how a role is created in order to make the sustainability of online communities work. This paper argues that brand loyalty plays an important part in keeping online brand communities alive.

Identifying loyal brand advocates and continually engaging with them over the long term is an important activity for any SME. The lessons from face to face community-building can apply here. For example, having a chat with a loyal customer about their views of the products and services is a good strategy to develop their level of engagement. Hearing their views and taking into account their opinions can help to refine the product and services offerings.

In addition, our study explores the influence of consumer engagement on brand loyalty as one of the key roles in business success.

From a managerial perspective, the findings of this study demonstrate the importance of consumer engagement in an online brand community for companies aiming to establish and maintain a competitive advantage. The findings also highlight three practical task and theoretical constructs to achieve brand loyalty via developing and managing online brand community for marketers and businesses.

References:

- Aaltonen , S, Kakderi, C, Hausmann, V and Heinze , A (2013) Social media in Europe: Lessons from an online survey, in: 18th UKAIS Annual Conference: Social Information Systems, 19-20 March 2013, Worcester College, Oxford, UK.
- Alghesheimer, R., Dholakia, U.M. & Herrmann, A. (2005) The Social Influence of Brand Community: Evidence from European Car Clubs. *Journal of Marketing*. 6919–34.
- Brodie, R.J., Illic, A., Juric, B. & Hollebeek, L. (2013) Consumer engagement in a virtual brand community: An exploratory analysis. *Journal of Business Research*. 66105–114.
- Carlson, B.D., Suter, T. a. & Brown, T.J. (2008) Social versus psychological brand community: The role of psychological sense of brand community. *Journal of Business Research*. [Online] 61 (4), 284–291. Available from: doi:10.1016/j.jbusres.2007.06.022 [Accessed: 26 February 2014].
- Davis, F.D., Bagozzi, R.P. & Warshaw, P.R. (1989) User Acceptance of Computer Technology: A Comparison of Two Theoretical Models. *Management Science*. 35 (8), 982–1003.
- Dholakia, U.M., Bagozzi, R.P. & Pearo, L.K. (2004) A social influence model of consumer participation in network- and small-group-based virtual communities. *International Journal of Research in Marketing*. [Online] 21 (3), 241–263. Available from: doi:10.1016/j.ijresmar.2003.12.004 [Accessed: 20 February 2014].
- Van Doorn, J., Lemon, K.N., Mittal, V., Nass, S., et al. (2010) Customer Engagement Behavior: Theoretical Foundations and Research Directions. *Journal of Service Research*. [Online] 13 (3), 253–266. Available from: doi:10.1177/1094670510375599 [Accessed: 24 February 2014].
- Hamilton, V.L. (1999) *Identification as a Challenge to Dual- Process Theories of Persuasion*. 65–76.
- Heinze, A, Ferneley, E and Child, P 2013, 'Ideal participants in online market research: Lessons from closed communities' , *International Journal of Market Research*, 55 (6) , pp. 769-789.

- Hoffman, D.L. & Novak, T.P. (2000) *Marketing in Hypermedia Computer-Mediated Environments : Conceptual Foundations * Marketing in Hypermedia Computer-Mediated Environments : Conceptual Foundations*. 60 (1), 261–290.
- Hollebeek, L.D. (2011) Demystifying customer brand engagement: Exploring the loyalty nexus. *Journal of Marketing Management*. [Online] 27 (7-8), 785–807. Available from: doi:10.1080/0267257X.2010.500132 [Accessed: 25 February 2014].
- Jones, D.A., Shultz, J.W. & Chapman, D.S. (2006) Recruiting through job advertisements: The effects of cognitive elaboration on decision making. *International Journal of Selection and Assessment*. 14 (2), 87–191.
- Kelman, H.C. (1974) Social influence and linkages between the individual and the social system: Further thoughts on the processes of compliance, identification, and internalization. In J. Tedeschi (Ed.), *Perspectives on social power* . pp.125–171.
- Kuo, Y.-F. & Feng, L.-H. (2013) Relationships among community interaction characteristics, perceived benefits, community commitment, and oppositional brand loyalty in online brand communities. *International Journal of Information Management*. [Online] 33 (6), 948–962. Available from: doi:10.1016/j.ijinfomgt.2013.08.005 [Accessed: 21 January 2014].
- Li, C.-Y. (2013) Persuasive messages on information system acceptance: A theoretical extension of elaboration likelihood model and social influence theory. *Computers in Human Behavior*. [Online] 29 (1), 264–275. Available from: doi:10.1016/j.chb.2012.09.003 [Accessed: 24 February 2014].
- Manchanda, P., Packard, G. & Pattabhiramaiah, A. (2012) *Social Dollars : The Economic Impact of Customer Participation in a Firm-sponsored Online Community*. pp.11–115.
- Marge, M., Banerjee, S. & Rudnicky, A. (2010) Using the Amazon Mechanical Turk for transcription of spoken language. In: *Acoustics Speech and Signal Processing (ICASSP)*. 2010 Dallas, TX, 2010 IEEE. pp. 5270–5273.
- Mason, W. & Suri, S. (2012) Conducting behavioral research on Amazon’s Mechanical Turk. *Behavior research methods*. [Online] 44 (1), 1–23. Available from: doi:10.3758/s13428-011-0124-6 [Accessed: 23 February 2014].
- Mollen, A. & Wilson, H. (2010) Engagement, telepresence and interactivity in online consumer experience: Reconciling scholastic and managerial perspectives. *Journal of Business Research*. [Online] 63 (9-10), 919–925. Available from: doi:10.1016/j.jbusres.2009.05.014 [Accessed: 21 January 2014].
- MSI - Marketing Science Institute (2010) *2010-2012 research priorities*. [Online]. 2010. MSI. Available from: http://www.msi.org/pdf/MSI_RP10-12.pdf. [Accessed: 25 February 2014].
- Muniz, A.M. & O’Gunin C, T. (2001) Brand Community. *Journal of Consumer Research*. 27 (4), 412–432.
- Petty, R.E. & Cacioppo T., J. (1986) *Communication and persuasion: Central and peripheral routes to attitude change*. New York, Springer-Verlag.
- Petty, R.E. & Wegener, D. (1999) The Elaboration Likelihood Model: Current Status and Controversies. In: Yaacov Trope (ed.). *Dual Process Theories in Social Psychology*. Guilford Press.
- Shen, A.X.L., Lee, M.K.O., Cheung, C.M.K. & Wang, W. (2011) We-Intention to Use Instant Messaging for Collaboration□: A Social Influence Model. In: *11th Pacific-Asia Conference on Information Systems*. 2011

- Snow, R., Connor, B.O., Jurafsky, D., Ng, A.Y., et al. (2008) Cheap and Fast — But is it Good? Evaluating Non-Expert Annotations for Natural Language Tasks. In: *Emperical Methods in Natural Language Processing*. 2008 New York, ACM. pp. 254–263.
- De Valck, K., Bruggen H. van, G. & Wierenga, B. (2009) Virtual Communities: A marketing perspective. *Desicion Support System*. 47185–203.
- Wirtz, J., Ambtman, A. Den, Bloemer, J., Horváth, C., et al. (2013) Managing brands and customer engagement in online brand communities. *Journal of Service Management*. [Online] 24 (3), 223–244. Available from: doi:10.1108/09564231311326978 [Accessed: 22 February 2014].
- Yu, J., Jiang, Z. & Chan Chuan, H. (2007) A Model of Identity Credibility in Virtual Communities: An Elaboration Likelihood Model Perspective. *The 13th Americas Conference on Information Systems (AMCIS)*.
- Zhou, T. (2012) Understanding users' initial trust in mobile banking: An elaboration likelihood perspective. *Computers in Human Behavior*. [Online] 28 (4), 1518–1525. Available from: doi:10.1016/j.chb.2012.03.021 [Accessed: 25 February 2014].

Appendix

Constructs	Measures
Information Quality	<ol style="list-style-type: none"> 1. The information provided in the OBC is accurate. 2. The OBC provides me with a complete set of information. 3. The information from the OBC is always up to date. 4. The OBC provides me with all the information I need.
Group Norm	<p>It was requested the respondent to consider the engagement in OBC as a goal. The respondents were asked to estimate the strength to which each holds the goal:</p> <ol style="list-style-type: none"> 1. Strength of the goal by yourself. 2. Average of the strength of the goal by other members.
Brand Community Identification	<ol style="list-style-type: none"> 1. I am very attached to the brand community. 2. I see myself as a part of the brand community. 3. I am an important member of the brand community. 4. I am a valuable member of the brand community. 5. I see myself as belonging to the brand community.
Brand Identification	<ol style="list-style-type: none"> 1. To what extent does your perception of who you are (i.e., your personal identity) overlaps with your perception of what brand represents (i.e., brand identity)? 2. When someone praises the brand, it feels like a personal compliment. 3. I believe others respect me for my association with the brand. 4. I consider myself a valuable partner of the brand. 5. I feel like I am personally connected to the brand.
Consumer Engagement	<ol style="list-style-type: none"> 1. I regularly provide new information about the brand to other community members. 2. I am motivated to participate in the OBC because I am able to satisfy my personal goals. 3. I am motivated to participate in the OBC because I am able to support others. 4. I am motivated to participate in the OBC because I am able to socialize with other community members. 5. I am motivated to participate in the OBC because I am able to help company to provide better products and services.
Brand Loyalty	<ol style="list-style-type: none"> 1. I encourage relatives and friends to buy the products and services of the brand. 2. I consider the brand as my number one choice. 3. It is very important for me to buy the products and services of this particular brand rather than other brands. 4. I intend to buy the other products of this brand in future.