



# Research and Development in the field of Energy Conservation and Renewable Energy in Thailand

[Link to publication record in Manchester Research Explorer](#)

## Citation for published version (APA):

Thalang, T. N., Sangmahachai, K., Sathitkunarath, S., Hitachad, A., Lorsong, R., & Pongsatittham, P. (2013). *Research and Development in the field of Energy Conservation and Renewable Energy in Thailand*. (1 ed.) Department of alternative energy development and efficiency.

## Citing this paper

Please note that where the full-text provided on Manchester Research Explorer is the Author Accepted Manuscript or Proof version this may differ from the final Published version. If citing, it is advised that you check and use the publisher's definitive version.

## General rights

Copyright and moral rights for the publications made accessible in the Research Explorer are retained by the authors and/or other copyright owners and it is a condition of accessing publications that users recognise and abide by the legal requirements associated with these rights.

## Takedown policy

If you believe that this document breaches copyright please refer to the University of Manchester's Takedown Procedures [<http://man.ac.uk/04Y6Bo>] or contact [uml.scholarlycommunications@manchester.ac.uk](mailto:uml.scholarlycommunications@manchester.ac.uk) providing relevant details, so we can investigate your claim.





Department of Alternative  
Energy Development and Efficiency  
**MINISTRY OF ENERGY**

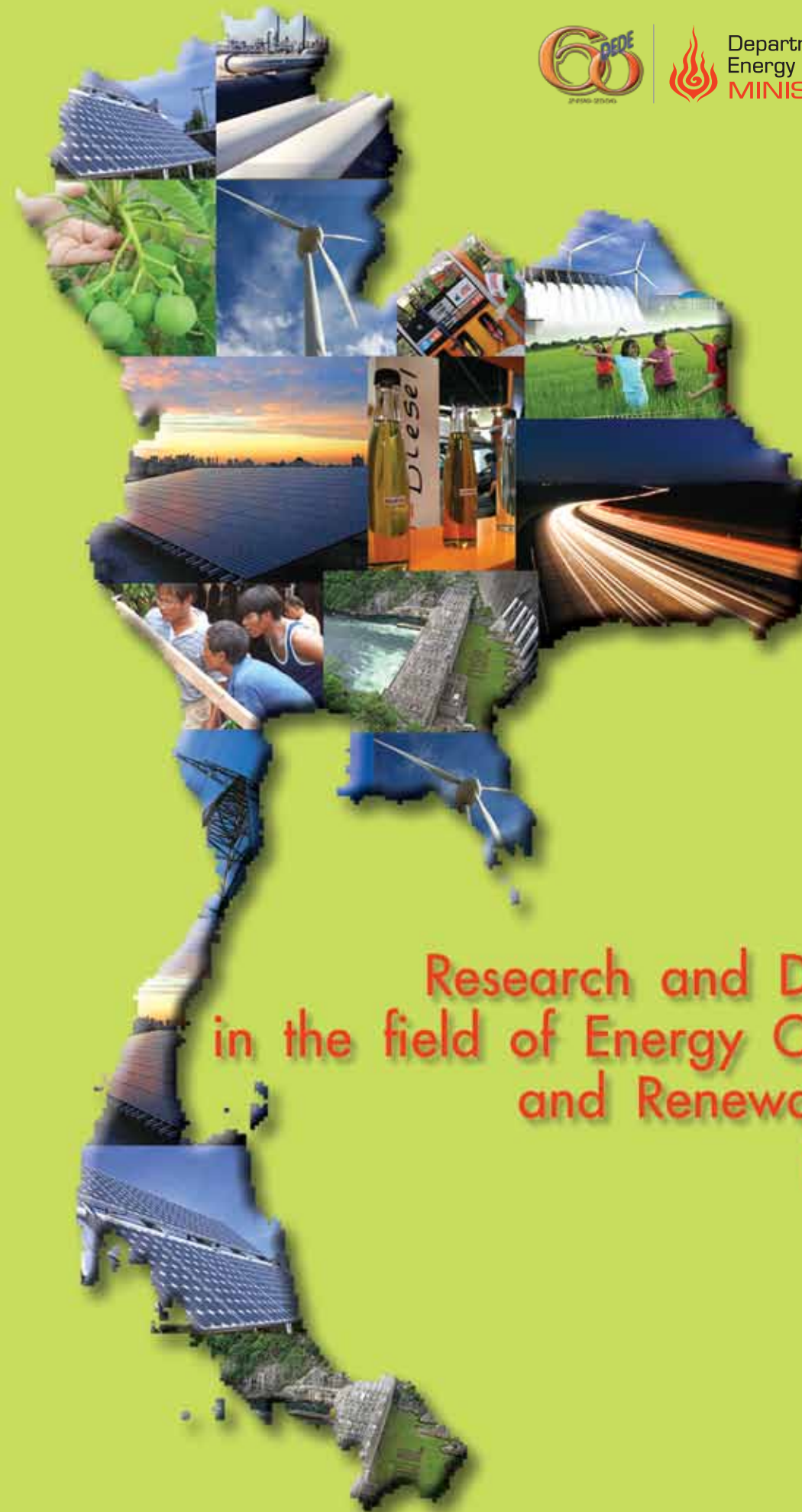

## Research and Development in the field of Energy Conservation and Renewable Energy in Thailand



Department of Alternative Energy Development and Efficiency (DEDE)

Research and Development in the field of Energy Conservation and Renewable Energy in Thailand

Department of Alternative Energy Development and Efficiency (DEDE)  
Ministry of Energy

17 Rama 1 Rd, Kasatsuk Bridge, Pathumwan, Bangkok 10330.

Tel. 0 2223 2593-5, 0 2222 4102-9 Fax. 0 2225 3785

[www.dede.go.th](http://www.dede.go.th)

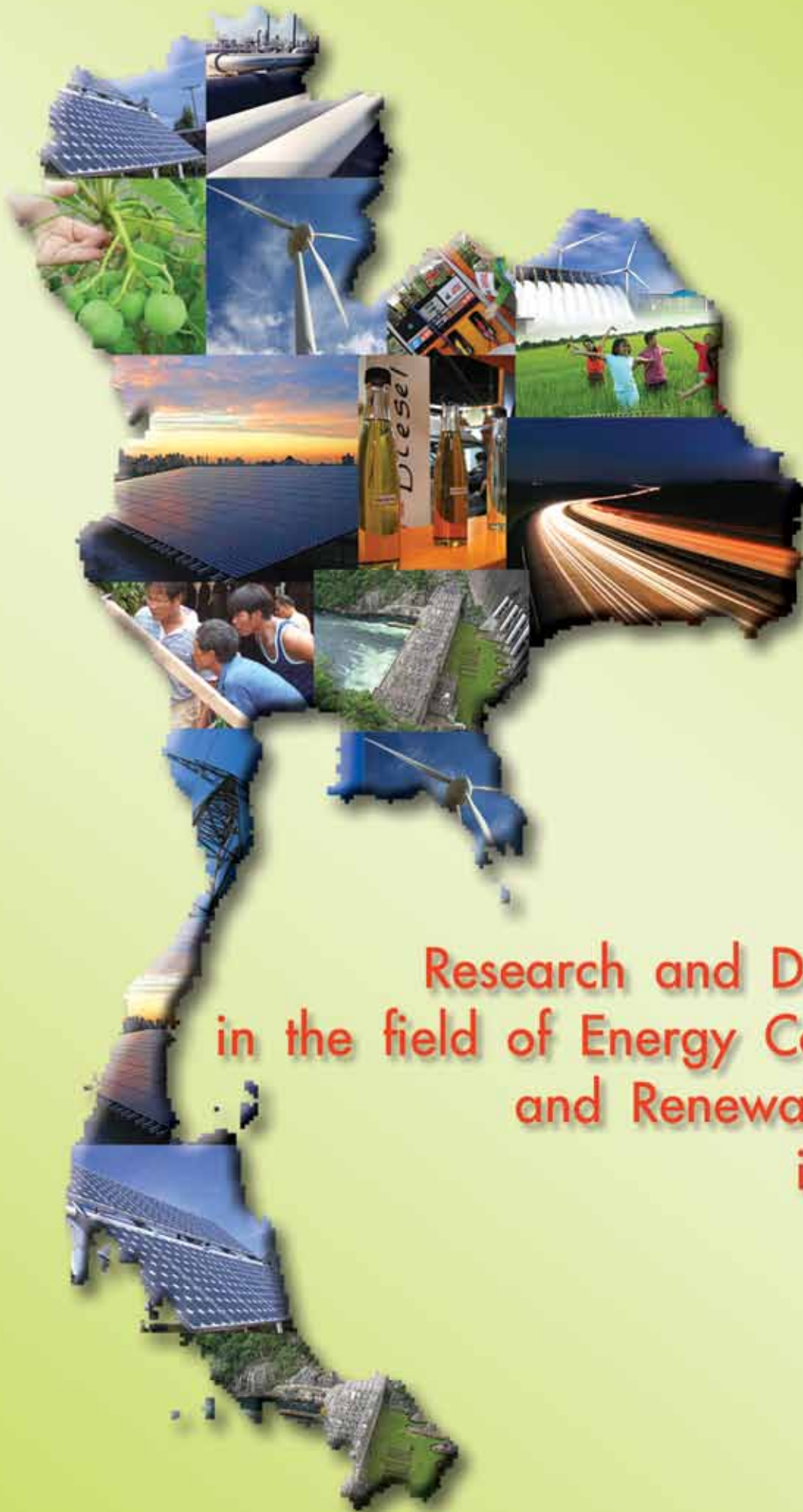

Research and Development  
in the field of Energy Conservation  
and Renewable Energy  
in Thailand

# Preface

**T**he Department of Alternative Energy Development and Efficiency (DEDE) has functions to develop, promote and support the production and use of clean energy and energy conservation, leading the country towards the energy knowledge-based society for economic prosperity, social sustainability and people well-beings. To achieve this inspiration mission, alternative energy has been undoubtedly brought into the concept for petroleum replacement together with energy conservation development to help decrease imported energy.

From the vision to become the renewable energy and energy conservation knowledge-based, and low-carbon society, “the 10-Year Alternative Energy Development Plan” was set up, aiming to reach 25,000 ktoes of renewable energy consumption, or 25% of the total energy consumption. Moreover, the Ministry of Energy has set up the 20-Year Energy Efficiency Development Plan (2011-2030), targeting to reduce the energy intensity by 25% in 2030, or not over 11.7 ktoe/billion Baht of GDP. These two major plans, however, will be successfully implemented by the following strategic actions under the authority of DEDE: revision of rules and regulations that favor alternative energy development, incentive support and promotion, awareness campaign, behavioral change, government decentralization on energy efficiency promotion to government and private agencies that are in readiness of resources and expertise.



Apart from those measures and strategies, DEDE is now ready to step forward into the knowledge-based society with the new vision to promote sustainable renewable energy and energy conservation through the knowledge-based organization. In light of this vision many projects have been initiated and implemented aiming to achieve AEDP and EEDP's goals. Ongoing projects also aim to promote and provide the right direction for energy research & development, which is vital for creating the knowledge-based society.

On the occasion of DEDE's 60th Anniversary in 2013, DEDE has prepared this publication compiling many research and development projects related to renewable energy and energy conservation in Thailand. The primary objective of this publication is to update research and development related to energy technology, its recent innovation as well as other interesting information to the public and those who are interested. It is expected that this publication will be beneficial and valuable to all agencies, individuals and other interested parties.

December 2012



# Contents

<b>Research and Development in the field of Energy Conservation</b>	<b>7</b>
<b>Energy Conservation Technology in the Industrial Sector</b>	<b>9</b>
<b>Cross-cutting Technology</b>	<b>11</b>
● Electric Motor	11
● Boiler	14
● Chiller	16
<b>Industry-specific Technology</b>	<b>17</b>
● Non-metal Industry	17
● Food and Beverage Industry	19
● Chemical Industry	20
● Textile Industry	20
● Metal Product Industry	21
● Paper Industry	22
<b>Research on Energy Conservation Technology in Commercial Building and Residential Sectors</b>	<b>24</b>
<b>Building Envelope</b>	<b>28</b>
● Insulation	28
● Glass	30
● Building Design and Appropriate Technology	31
<b>Air-conditioning and Ventilation System</b>	<b>32</b>
● Conventional Air-conditioning system	32
● Alternative Air-conditioning System	33
● Solar Cooling	33
● Desiccant Air-conditioning	34
● Radiant Cooling	34
● Thermal Comfort	34

<b>Illumination in Buildings</b>	<b>35</b>
● Lighting System	35
● Lighting Equipment	35
● Design and Its Appropriate Technology	36
● Daylighting Application	36
● Amount of Daylight and Sky Luminance Distribution	37
● Daylighting Technology	37
<b>Water Heating</b>	<b>38</b>
<b>Research on Energy Conservation in Transport Sector</b>	<b>39</b>
<b>Research and Development in the field of Renewable Energy</b>	<b>48</b>
Solar Energy And Related Technologies	53
Wind power and Related Technologies	64
Hydro Power and Related Technologies	70
Waste and Related Technologies	74
Biomass and Related Technologies	77
Biogas and Related Technologies	81
Ethanol and Related Technologies	85
Biodiesel and Related Technologies	91
<b>Conclusion</b>	<b>96</b>
<b>References</b>	<b>103</b>







# Research and Development in the field of Energy Conservation





## Research and Development in the field of Energy Conservation

**T**his report is basically a compilation of 279 pieces of research work in Thailand during the year 1996-2012 focusing mainly on the energy efficient technology and energy efficiency which can be categorized into such economic sectors as industries, buildings, residents and transport. Of all these researches, energy efficiency had 54.48% relating to commercial buildings, 24.01% to industries and 8.60% to transport. Meanwhile, 8.24%, and 4.66% have been related to economics & policy, and households respectively. The illustration of the research work is shown in Figure 1.

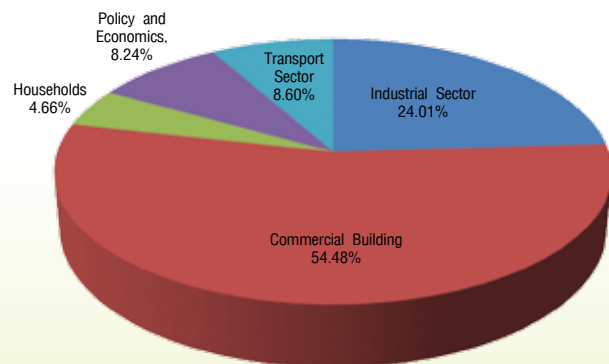

Figure1 : Energy Conservation Research Proportion Categorized by Economic Sectors during 1996-2012

# Energy Conservation Technology in the Industrial Sector

Energy usage in the industrial sector accounts for 36% of the country's final energy consumption. It is in the forms of heat and electricity accounting for 80% and 20% respectively. It is estimated that high energy efficient technologies for heat and electricity would have potential more than 22% at the business as usual. They are essentially identified as follows;

**1. Cross-cutting technology** can be classified as motor, electric motor drive system (pump, fan, compressor), boiler/steam system and chiller which can generally be found in most industries. Many countries have tremendously gone far for their research and development of these technologies such as the development of high efficiency motor, the development of variable frequency drive, the composition of various energy efficiency technologies for super boiler. Likewise, the water chiller has also been developed to consume less energy in the system. Some of them, however, are at the stage of research and demonstration, while the others have been placed in the market.

**2. Industrial-specific technology** includes; glass recycling, high efficiency cement kiln, efficient ceramic and brick kiln, high efficiency/low NOx burner, membrane technology, high capacity aluminum melt furnace and energy efficient textile finishing process. In Thailand, they are usually found in the industries with high energy demand.



**Table 1 Energy Conservation Technologies (3)**

<b>Industries</b>	<b>Specific-Technologies</b>	<b>Cross-cutting Technologies</b>
1. Non-metal (cement, glass, ceramic)	<ul style="list-style-type: none"> <li>• High efficient burner</li> <li>• Glass recycling</li> <li>• High efficient cement kiln/brick/ceramic</li> <li>• Roller kiln</li> </ul>	<ul style="list-style-type: none"> <li>• Motor and electric motor drive system for pump/fan/compressor</li> <li>• Boiler</li> <li>• Chiller</li> <li>• Waste heat recovery</li> <li>• CHP</li> </ul>
2. Food and beverage	<ul style="list-style-type: none"> <li>• Membrane</li> </ul>	
3. Chemicals	<ul style="list-style-type: none"> <li>• Membrane</li> <li>• Gasification technology</li> </ul>	
4. Primary metal	<ul style="list-style-type: none"> <li>• Smelt/reduction process</li> <li>• Near net shape/Strip casting</li> </ul>	
5 Paper and paper pulp	<ul style="list-style-type: none"> <li>• Energy efficient drying</li> <li>• Black Liquor Gasification</li> </ul>	

Combined heat and power or “CHP” is the technology to increase energy efficiency with the combined system working together between heat and electricity production and CHP. The technology has 2 main components; power generator and heat recovery system. It offers higher efficiency than separated power and heat generation technology. The CHP can be found in several technologies such as steam turbine, gas turbine, gas engine, stirling engine, and fuel cell, while waste heat recovery and efficiency improvement of the heating and cooling process are considered to be prioritized.



## Cross-cutting Technology

There are many cross-cutting technologies in the industrial production process. “The Motor” is an example that has commonly been used with other devices with many functions i.e. driving a pump for liquid transfer, a belt to haul up materials and installing with trucks or wheeled vehicles to transport equipment/machineries. “The Boiler”, is another technology that is very important and used for heating process in industries. “The Boiler”, with its functions to change fuels to heat process, ranges from less-required temperature dryer to very high temperature-needed steam turbine. These well-known and commonly-used devices reflect the result of their development which have vastly contributed to energy efficiency potential and, consequently, create more opportunity for further design and manufacturing in the country than any other technologies (3).

## Electric Motor

The electric motor is a basic tool used in many industries. Generally, motors sold in a market have 2-7% efficiency lower than high efficiency motors, depending on their size. The efficiency of motors will be decreased by 1-5% per year and by 20% when its life time is more than 15 years. Of all the motors being installed in the country, 95% of them are low efficient - as commonly known as “standard motors, merely 5% of them are high efficient but have to be imported with the price of 30-50% higher than the standard motors. It could generally be figured out that, if the standard motors could be replaced by the high efficient ones, the energy would be save by 3%, and by 2030 an accumulated energy saving would reach by 1,157 ktoe.

Currently, both phase one and phase three induction motors have been tremendously used in Thailand to drive pumps, fans, and compressors. However, many countries like Japan and the United States of America have used brushless DC motors for compressors and permanent magnetic synchronous motors for pumps and blowers, since these two types of motors have higher efficiency, and to some extent, more advantages in their small size and light weight than induction motors. An electric motor has several kinds of techniques, to be cited here are “variable frequency method”, designed for speed control in induction motor that links with variable torques in pumps and fans. This method, known by the industries as Variable Frequency Drive (VFD), somehow, cannot be applied for other types of motors except for those previously mentioned.



**Electricity saving in the electric motor drive system, especially in pumps, fans, electric motors and compressors can be implemented by the following 2 categories;**

(1) Select various devices in the system for more efficient use i.e. electric converter circuits, electric motors, fan pumps or compressors. Their research would be concentrated on materials used in the devices or high efficient techniques applied in other equipment.

(2) Modify the operation process of pumps, fans and compressors. Since these devices are mostly operated in the Thai industries by switching on motors all the time or by the on-off control, resulting in the full-ranged electric power use, and therefore, requiring more electric power than necessary. This consequently leads to the huge amount of energy loss. In order to save energy, the devices should be modified with efficient variable-speed control so that electric power can be reduced. The method is aligned with the theory of the affinity law of fans/pumps that electric motor power is variable to the cube of motor speed. In other words, electric power can be reduced when electric motor speed is proportionally adjusted in the process. Besides, the high inrush current occurs with the direct turn-on of motor at the value of 4-6 times of the current rating. But this case can be eliminated by VFD.

The induction motor is one of the most commonly used equipment nowadays. There are many kinds of induction motors such as, first phase and three phase with various capacity of power rating, except for the very big ones. The reasons of their popularity are due to the directly connected potential with alternating current, easy purchasing, cost effectiveness, and easy speed motor modifying methods. The efficiency of induction motor at 1-4 horsepower rate can make 80% of power value and will increase up to 93% if the high horsepower rate increases by 125. Therefore, the high efficient induction motor has been promoted for industrial operation since it has 3% (average at some horsepower rate) efficiency higher than the induction motor. This higher efficiency resulted from; reducing losses from coil wiring, the magnet made from good metal quality, the motor dynamic improvement and motor spare parts error correction. The high efficient motor has 5 different types and is 20% more expensive than the induction motor. However, there is a need for the motor to be further developed and studied in order to increase efficiency, reliability and commercial purpose.

(1) **The superconductor motor** has been designed to replace the copper coil with the high temperature super conductor (HTS) to create higher power of electromagnetic when the temperature is very low. HTS has no copper losses and works at the temperature of -173



to -195 degree Celsius. It is highly efficient, compact, safe and suitable for big motors (1,000-7,000 horsepower)

(2) **The permanent magnet motor** generates a magnet field from the permanent magnet in motors to replace a field coil. Some examples are; DC servo motor, stepping motor, brush DC motor or Permanent-magnet synchronous motor. At present, the phase three permanent synchronous motor and brushless DC motor have been widely used in foreign countries, mostly in the forms of pumps, fans, and compressor, but not much popularly used in Thailand.

(3) **The copper-rotor motor** has been introduced with the aluminum made for 6-7 years. Now it is made of copper and has 60% higher potential to induce current than aluminum, consequently accelerate efficiency. However its casting is not well installed and needs more research and development.

(4) **The switched reluctance motor (SRM)** has both stator and rotor with the salient pole characteristic. The stator has only concentrated winding. SRM does not require permanent magnet nor carbon. It includes many phases i.e. 3-phase, 4-phase or 5-phase. Configuration of stator and rotor is not yet up to the standard and depends on manufacturers and designers. Though SRM has long been developed, it has not been commonly used due to the limited low speed rolling and less reliability. The modified high speed equipment such as vacuum cleaner, driving system in military work, power generation, motor/pump of airplanes use SRM which is quite expensive.

(5) **Written Pole (WP)** is a motor modified from a single-phase induction motor with the patent registered by Precision Power Corporation. It is configured by increasing coil to create magnetic pole at rotor skin made from magnetic material. WP has good characteristics in helping motor start by reducing inrush current, thereby, increases efficiency. At present, WP has limited size at 15-75 hp and is being used in irrigation water pumping, belt motor, water pump, etc.

More than half of the electrical equipment have been configured by motors such as air-compressors, pumps and fans. However, they still face some hindrances in having their sizes bigger than necessary, resulting in a low efficient system. It is found that air-compressors, fans and pumps are widely used in the country. Most of them are designed and made in Thailand, but are not somewhat aligned with a turbo-machine which may cause low efficiency comparing to those made abroad.



- **Air Compressor**

The newly developed technology to increase efficiency in air compressor is “advanced compressor control” which makes the air compressor work harmoniously and nearly to the most efficient point. The advanced compressor with VFD can work with low speed drive instead of the high speed one as in the case of general steam compressor. The electric power reduction can be 35% at the maximum.

- **Pump**

The pump is designed for high efficiency under the turbo-machines theory. Key factors effecting the pump’s efficiency is the design of pump entry, liquid flow rate, pump impeller design, liquid property, and variable speed drive control. The selection of suitable high-efficient pump and VFD installation can also help reduce electric power.

- **Fan**

The fan is the industrial device available in many types and sizes. The fan efficiency improvement can be done not only by applying the high efficient motor and installing variable speed drive but also by other techniques such as the design of blade and casting shape, a control of variable speed drive and cross-section of the air flow.

## Boiler

The boiler is one of the most important equipment which has been used across the process industries. The average of the boiler’s efficiency in developing countries is 65%. The measures and methods of the boilers’ improvement can made simple with less cost but result in energy saving ranging from 10 to 20%, possibly without changing the new boiler. In the United States of America, the research was focused on high efficient boiler development, termed as “Super Boiler”. It is a new type of boiler that has been continuously developed. At the beginning of the research, the boiler could gain high efficiency up to 92% with low NO<sub>x</sub> emission. The super boiler has two components, boiler and heat recovery, being configured with new innovation i.e. Transport Membrane (TM) Condenser, Compact Air Heat for eliminating Sensible and Latent Heat from exhaust and stage/intercooler combustion. The energy efficiency and steam production rate can be increased accordingly. (See Figure 2 and 3).



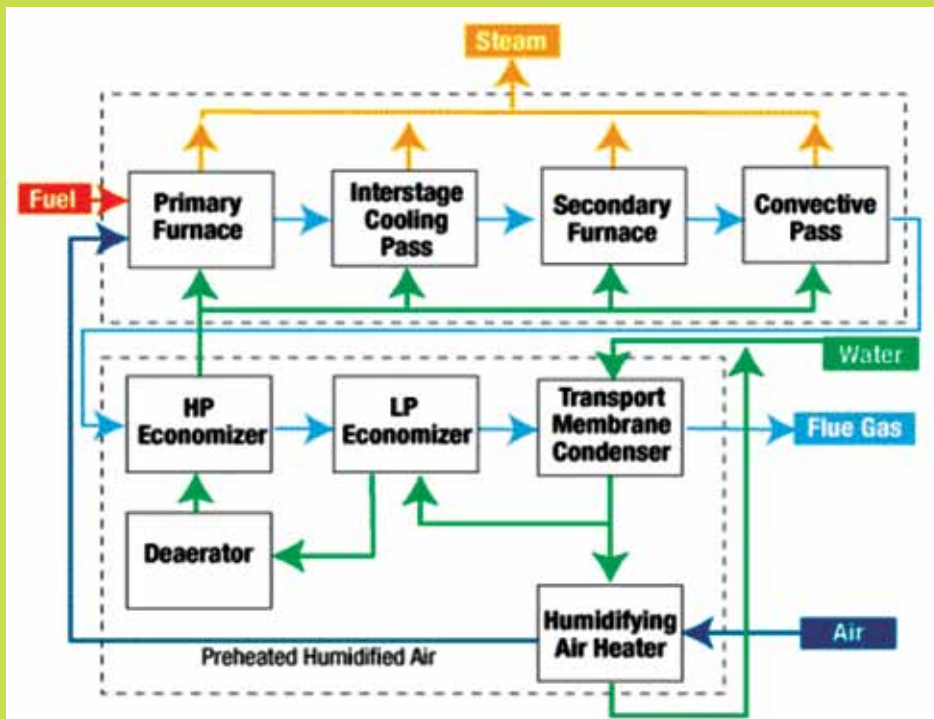

Figure 2: Two-stage Super Boiler [4]



ပုံ ၃ Two-stage Super Boiler [5]



From the current country's perspective, if existing boilers have been replaced by super boilers, the energy saving would be 16%, or 9,495 ktoe of accumulated energy saving within 2030. It is estimated that the price of the super boiler would be 5-20% higher than the normal boiler which costs approximately 700,000 Baht/ton boiler, while super boiler would cost approximately 1,000,000 Baht/ton boiler, making approximate price differentiation at 640 Baht/HP. It was found from the cost effectiveness evaluation that investing in the super boiler to replace the ordinary one would result in minus net expense/year since energy saving value is higher than the capital when calculated from expense per year.

## Chiller

The chiller is one of the most widely used equipment in industries with the objectives to adjust the air-conditioning and cool water maker. It is regarded as one among the very first devices of industrial machines which consumes high energy. Manufacturers put much effort to develop and improve the chiller to be more efficient with less consumed energy. Chillers prevailing in Thailand generally consume 7% of the total electricity usage. [5]

The high efficient chiller differs from other chillers because it has been designed with better control system and improved condenser, while having compressor without frictional force but high efficiency. Magnetic bearing in chiller works together with the control system. The ARI standard testing on 150 tons chiller with magnetic compressor showed that the chiller's efficiency would be as high as 0.629 kW/ton (COP = 5.6) at full load and 0.375 kW/ton (COP = 9.4) at 60% of chilled condition. At present, large scale manufacturers have to continue developing the high efficiency chiller, aiming to improve its efficiency to reach the target of 0.50 kW/ton of electricity usage for the whole system.



## Industry-specific Technology

Apart from cross-cutting technologies, the industry-specific technologies have also been developed in the industrial sector in order to reduce energy consumption in its production process. These technologies will be varied depending on each industrial sector. It is to be noted here that some technologies are still as yet to be in the process of research and development or demonstration for the commercial purpose in the next 20-30 years.

### Non-metal Industry

Major types of the non-metal industry in Thailand are cement, ceramic and glass. The energy efficient specific technologies of each industry can be highlighted as follows;

#### Efficiency Low NO<sub>x</sub> Burner

At present, gas and oil burner give low luminosity and unstable heat flux transfer, therefore, create hot spots therein and consequently affect the burned products.

High efficiency low NO<sub>x</sub> (HELN) which uses O<sub>2</sub> and has a heat transfer system to fuels can reduce NO<sub>x</sub> by 50% when used in glass burning, while heat efficiency will be 20% higher than the original performance. Currently, the oxy-fuel burner has been brought to operate in various industries such as glass, ceramic and steel.

#### Glass Recycling

Glass recycling has been used for glass packaging process totaling 70% in the United States, while 80% used in Europe. The energy consumption reduction can be done by using flue-gas from the combustion of burner to preheat glass particles with the high temperature of 300-540 degree Celsius. These glass particles can be brought for ceramic production with more energy saving in the production process. Burning of raw materials to make ceramic normally needs temperature at 1,200 degree Celsius, but burning glass particles to make ceramic can use temperature only at 760 degree Celsius, which can help reduce energy consumption by 50%.



## High-efficiency Cement, Ceramic and Brick Burning

Most of ceramic and brick manufacturing in Thailand are SMEs. They use the intermittent kiln that consumes high power. Such high power is brought to heat the kiln wall. The whole loss of heat goes in the air after finishing the burn. Loss of heat from the kiln wall, while being burned, is somewhat very high. The process also takes a lot of time.

**Energy efficiency can be increased with continuing burning process without heat loss while heating or cooling the kiln wall.**

- The low thermal mass tunnel kiln is the continuing burning technology where objects can be put through a tunnel. High efficiency will be derived from using elevated flame burner and ceramic-fiber insulation. The ceramic-fiber burner takes about an hour to increase heat at the working temperature, while the original one uses 24 hours. It creates high efficiency, and can save natural gas by 35% comparing to the original tunnel.

- The high efficiency cement-kiln is for cement production. The small kilns can be found in developing countries while the big sizes with high efficiency are common in developed countries. As the production process of portland cement-clinkers is a dry process that yields high energy efficiency, it is brought for the replacement of wet process in Europe. The portland cement production requires 3.7 GW/ton cement while the wet kiln needs energy more than 5.3-7.1 GW/ton. Another method to improve the rotary kiln's efficiency is to add cyclone preheaters from 4 to 6, resulting in fuel reduction by 10%.

- The new clinker design, so called the dry rotary kiln, is the most modern design for now. With an averaged high efficiency, the kiln consumes 3.0 GJ/ton of energy. However, attempts were made to develop other new technologies such as fluidized bed technology which has efficiency a little higher than the dry rotary kiln. Therefore, this proven dry rotary kiln will most probably be an appropriate technology for use for many years.

- The cement milling is the cement production process consuming highest energy. Today, the most modern milling technology is the use of the roller process and high-efficiency classifiers. However, it has efficiency only 5-10%. The rest of energy will be loosen through heat.

- An alternative fuels are found possible to replace fossil fuels for emission reduction. This includes biomass (wood chips and bark), tires, plastic, chemicals and waste. Industries in Belgium, France, Germany and Switzerland have utilized such alternative fuels to replace fossil fuels by 35-70%, or even 100% in some factories. But the use of large amount of



alternative fuel from waste requires the control system and needs appropriate property's improvement. For example, before utilizing waste, its property should be improved normally an gas emission should be taken out of cement kiln carefully. Cement industry in USA used about 56 million tires for fuels. It is estimated that biomass and wastes are used for cement production at the large amount of 112 PJ to 34 PJ respectively.

- The study also found that other materials are possible for substitution of clinker cement which consumes a lot of energy. In the future, there will be further development of new cement types without using limestone but new geopolymers instead.

## Food and Beverage Industry

### Membrane

This technology is important for acceleration of energy efficiency in food and chemical industries. It is used for separating one substance or more from liquid or gas which consumed high energy.

Membrane is made of organic or non-organic substances or both. Organic membrane forms the processed temperature lower than 100 degree Celsius, while non-organic membrane needs 500-800 degree Celsius. Metal membrane process requires temperature at 1,000 degree Celsius. But if the process temperature is higher than 1,000 degree Celsius, ceramic membrane can, then, be applied. Membrane works by separating the feed with one that can pass through the process called permeate and another called retentate which cannot pass through. Pressure or voltage is the driving force for mass transfer. Membrane uses low energy because there is no change of phase during the separation process.

There are various types of separation process, for example microfiltration or MF, ultrafiltration or UF, nanofiltration or NF, reverse osmosis or RO, electrodialysis or ED and gas separation. These processes have been comprehensively developed to the level of being applied across the country. Other membrane processes, however, are still being developed such as membrane contactor or MC or pervaporation being designed for water separation from alcohol. But, major technical problems still exist. At present, membrane technology is commonly operated in many areas such as clean water production from briny water, sea water and water treatment in many industries. Besides, food and beverage industries, chemicals, petro chemicals are also in operation with this technology.



In terms of energy efficiency, a food industry report from Canada indicated that the concentrated apple juice production by UF and RO together could gain energy saving by 60% comparing to an evaporation process. The same is in the olive oil industry which is reported that the application of UF and RO in waste water treatment could reduce energy cost by 30% comparing to biomass method.

## Chemical Industry

### Membrane

The membrane process in chemical industries is mostly used in petro chemical industries when, for example, applied as part of the production of polypropylene, polyethylene and vinyl acetate monomer. Natural gas industries also use the membrane process for CO<sub>2</sub> and H<sub>2</sub>S separation. So the same as the refinery industries that use membrane process to separate H<sub>2</sub> and reversed LPG. This technology also uses for the distillation of liquid membrane or liquid-liquid extraction, though not prevailing as yet. Generally, the membrane process could gain energy saving by 20% depending on the efficiency of each process, while the pay back period could be 5-10 years due to high investment and maintenance cost.

### Gasification

In the refinery process, where the production of lighter fraction such as gasoline is to be increased, a lot of heavy fraction and waste water come out. But they can be processed for fuel gasification, making more efficient use of energy. There is a lot of demand of hydrogen in the industrial process, part of it will be separated for other purposes and the rest will be used in the IGCC for power generation. The gasification can be seen from gas turbine operation where turbine's heated gas produces steam which is reused again in steam turbine or in other heating processes.

## Textile Industry

### Energy Efficient Fabric Finishing Process

Textile industries consume most energy and water in its finishing process where fabric passes through a substance container (diluted by water) and enters the step of pressing machine and vacuum dehumidification to take water out and finally sent into the dryer by



heat air so that the fabric's humidity will be decreased by 40-60%. This new technology dilutes substance with air instead of water. Fabric is then put in the mixed-air substance foam to make 20-25% of fabric's humidity. With this process, energy consumption is reduced without having the pressing machine and vacuum dehumidification in the system.

## Metal Product Industry

### High capacity aluminium melt furnace

The high capacity aluminum melt furnace needs high temperature and energy demand. The development of this technology has to be made for increasing energy efficiency. The original melting aluminum furnace transferred heat to the objects by electromagnetic wave radiation, making them received the heat only in the radiation direction. A new design is developed by transferring heat through convection at high temperature and make aluminum casting covered wholly by heat. Energy usage then is reduced by 0.5 kW/ton aluminum comparing to the original system.

### Smelt Reduction

The advanced blast furnace with high efficiency usually comes in large size, but its medium and small size can also reduce energy with smelt reduction. The steel production process consumes high energy when in the process of coke and ore preparation. In order to save energy, new system called "COREX" was developed and has been, later on, expanded for even higher efficient process, so called "FINEX". Apart from these technologies, hismelt process has also been introduced by using the same principle as smelt reduction.

Steel production with smelt reduction process not only uses lower efficiency than blast furnace, but heated gas from the production process having high energy of 9 GJ/ton of steel produced can be brought for direct steel blast. This results in the very high efficiency using energy only 10.7 GJ/ ton of steel produced, while blast furnace can uses high energy up to 17 GJ/ton of steel produced.

### Near Net Shape/Strip Casting

At present, metals have been casted into ingots or slabs by reheating them in the pressing process to be shaped out.

The near net shape (casting near and to the real) and strip casting are newly developed technologies with variety of product shaping as required. In the case of flat-plate product,



the casting will be made with 1.1mm thick and, after that, will be casted in the thick one with 120-130 mm thick. This way can save a lot of energy.

This technology has the advantages as it can reduce cost and has high volume of production and integrate are processes into one. It was firstly operated in the stainless steel production, and, later on, has been further applied for carbon steel by two manufacturers. Technologies that have been commercially introduced at the beginning are;

- **Castrip** – a technology developed by the cooperation between Australian and Japanese private sectors,
- **Eurostrip** – a technology developed by European countries which are Austria, France and Germany,
- **Nippon/Mitsubishi,**

Further research and development are, at present, as yet to be conducted in the scope of technology's quality through modification of production and casting process control. As a result, more product designs and large scale production can be extended. (Now, this technology has the production capacity only 500,000 tons/year).

In conclusion, using near net shape/strip casting essentially leads to energy saving, and investment cost comparing to other existing technologies. Energy saving from the technology can reach by 90% and the cost will be reduced by 30-60% due to the reduction of cast heating process.

## Paper Industry

### Energy Efficient Paper Drying Technology

Paper production process is divided into 4 steps which are stock preparation, sheet formation, dryer section and finishing products.

Dryer section is the high energy-consumed process. In order to reduce energy in such process, new technology will be applied to combine two processes together – stock preparation and sheet formation. This is designed specifically for long-nip or shoe press processes which are regarded as the most efficient advanced technology.

Condebelt is the drying technology where the paper continuously connects with heat iron surface making the drying rate increased by 5-15 times when compared to the old technologies.





Impulse drying is the sheet forming process technology with hot surface metals at high pressure. It has been continuously developed, and if achieved, is expected to reduce a large amount of energy. Technology of paper making has also focused further on dewatering to save energy in the sheet formation process. Therefore, the overall production process consumes less energy but still increase efficiency.

## Black Liquor Gasification

Black liquor is the waste resulting from the extraction of lignin from pulp wood in the paper making process. It is normally burned in the boiler for electricity and heat generation and brought for use again in the paper making process. But, due to its high liquid volume (only 65-75% of solid), the gasification efficiency is still low.

The gasification process of solid fuels can help black liquor more energy efficient. Black liquor can be processed into such gas fuels as carbon monoxide and hydrogen. These fuels, after passing purification process, will be used in gas turbines for power generation where waste gas will be brought for steaming. The system so called Black Liquor Gasification combined Cycle-BLGCC, can be useful not only for the efficient use of black liquor but also for other wastes from paper making process i.e. bark and chip wood. Another potential of fuels gas derived from black liquor is the production of chemicals and liquid fuels for transport. With the EU policy to increase biomass consumption in transport sector, there is an interest to create dimethylether (DME) for dieselsubstitute. Therefore, black liquor gasification development is not as yet up to the commercial scale, and required more research and development for the better system and more reliability.

In USA and Europe, there has been a huge investment of BLGCC installation which is 60-90% more than that of the boilers. An internal rate of return is assessed to have the value of 16-17% with the electricity sale price of 4 cents/kWh. In the case of USA, black liquor in paper making industries could generate electricity by 39.4 TWh in 2002, but if applied with BGLCC, electricity generation would be additionally increased by 50.2 TWh or 127%. It is expected from BLGCC development in terms of technology price and potential of energy consumption reduction in paper industries that the simple payback period of BLGCC investment will be 1.5 years.



# Research on Energy Conservation Technology in Commercial Building and Residential Sectors

Commercial and residential sectors consume energy by 8 and 15% of the total energy consumption respectively or 23% all together. Major energy consumption of these sectors is electricity. It is founded, when recursive calculated to be the primary energy that energy consumption of these sectors is as high as 30% of the total primary energy consumption (1.3). Electricity in building is used by 60% of air-conditioning and 20% of lighting. Electricity is also consumed in such appliances as refrigerator, fan, communication devices which are dramatically playing their roles in this era where information and communication technologies are increasingly important and widely applicable.

Major measures for supporting energy efficiency buildings are to set up the building energy code of new buildings and old buildings that are timely to be retrofitted as prescribed by the laws, and to promote development of higher energy performance standards or HEPS. These standard criteria include; building envelopes to reduce cooling load in air-conditioning system, energy efficiency of air-conditioning and lighting system. In Thailand, an average of energy consumption per unit area in big buildings is as high as 220 kWh/m<sup>2</sup>-year. But the buildings that fall under the building energy code and high efficient ones use energy only 175 and 55 kWh/m<sup>2</sup>-year respectively. This reflects a big room for improving energy efficiency. As a matter of fact, if buildings have been designed since the beginning with advanced energy saving concept and built with high efficient technology and equipment, energy consumption would be reduced to near net-zero or about 25-50 kWh/m<sup>2</sup>-year. At present, many demonstration buildings have been constructed even in Malaysia and Singapore. Further development is still moving on to make the technology cheaper. With regard to small commercial buildings and households, energy saving potential depends on high efficient electric equipment and appliances, especially an air-conditioner and cooking stove. For the building designs that reduce air-condition work load will be potentially last for long but has to be designed a long the line with the tropical whether. The study of 20-Year Energy Efficiency Development Plan (6) found that small commercial buildings and households can save energy by 20-25% of the total energy consumption at a business as usual in 2030 (5).

The following table is the examples of technology that should be developed and applied in buildings.



Table 2 Energy conservation technologies in commercial buildings and households (3)

<b>Energy Conservation Technologies in Commercial Buildings and Households</b>	
1. Building envelope and design	1.1 Wall materials and glass 1.2 Insulated envelope – can optimize natural light and make thermal comfort in the building 1.3 Envelope design to make use of daylight
2. Air conditioning and ventilation and thermal comfort	2.1 High efficient air-conditioner 2.2 Options for cooling i.e. solar cooling, passive cooling and hybrid system for thermal comfort in the building in thailand
3. Use of daylight and light innovation	3.1 High efficient lamps (and their components) i.e. LED 3.2 Daylight innovation and its integration with artificial light (lighting) 3.3 Illuminating design innovation
4. Equipment and appliances in building	4.1 Refrigerator and cooling retention 4.2 Air-condition 4.3 Cooking stove 4.4 General electric appliance i.e. fan, water pump 4.5 Electric appliance using low interrupt power supply
5. Controlling system and building management	5.1 Methods and procedures to follow up and control energy use for activities in particular area such as tasked lighting 5.2 Methods and procedures for energy management with building automation system or BAS
6. Cogeneration (CHP) and district cooling	6.1 Combined heat and power system by using clean energy i.e. natural gas , including district cooling 6.2 Absorption cooling using waste heat



The commercial building and household technology have specific features and differ from other technologies. The working system of building has been linked with and highly influenced by geographical areas where buildings are situated. It also depends on other external factors (sun radiation, daylight, wind, temperature, humidity etc.) which vary at all time and by seasonal change. The potential of energy use and conservation therefore face complexity and do not depend on the technologies themselves but on how technologies can be applied. The results of the research work on specific surroundings and geographical spot are then very necessary to be reviewed and evaluated if it need be applied in other distinct areas (7).

Buildings have various systems working in harmony to provide services and facilities therein. The building envelope, lighting and air-conditioning systems are 3 main building systems that consume energy up to 70-80% of the total energy consumption in the buildings. Moreover, there are other energy-used equipment in the building i.e. elevator, pump, office supplies etc. (8). Mr.Surapong Jiratananont and the group (7) gave some conclusions on the research work on energy conservation technologies in commercial buildings and households as follows;

- **Building envelope:** In the tropical region, efficient building envelopes help reduce cooling load in the air-conditioning system. A research was conducted on a new insulation design focusing on high thermal resistance and less space requirement. An application of insulation with high efficient roof can reduce refrigeration. However, using insulation with walls can have both advantages and disadvantages, depending on the building's utility. A good quality of building envelope would bring a large amount of daylight into the building. Glass is also developed for better heat protection, while more daylight can be easily passed through. Sun shading being installed on the window can be a very effective way to protect direct sun radiation, without blocking daylight coming in. This is clearly indicated that research works are necessary for the development of materials and designs with correct understanding to make the building envelope more efficient.

- **Air-conditioning system:** The research on conventional air-conditioning system has been focused on technologies for power reduction per thermodynamic cooling capacity. Examples are; increasing compressor efficiency, the use of variable speed drives, electronic thermostats, and controlling an equipment operation in the system. For the ventilation

system that works jointly with air conditioning system, the ventilated air volume control can be applied to reduce air conditioning load. Alternative air-conditioning system i.e. the radiant cooling system is the real sample being installed in the building and can reduce energy consumption by 30%. Right now, the solar cooling system has been accepted widely and continuously. The alternative air-conditioning system has to be studied simultaneously with the thermal comfort due to their different methodology from other normal practice.

- **Lighting system:** The study focuses on increasing efficiency of such equipment as; an increase of light bulb efficacy, LED development, reflect lamp, high efficient ballast and dimming-control technology. As electricity demand in the lighting system decreases, cooling load in the air-conditioning system will also be decreased. Daylight is very important due to its high potential in energy consumption reduction of lighting system in the entire building. Using daylight in buildings appropriately will help reduce the heat load of air-conditioning system.

- **Other energy equipment and systems:** This includes, among other, controlling heating and cooling by the heat pump, solar water heater and the development of solar hot water panel system as part of building integrated solar water heater, the development to help reduce energy consumption in such electric appliances as refrigerator, television, radio, computer, and 1W power standby technology.

- **Power generation system:** Power generation technology for energy supply in the building is also included as part of the development. Obviously seen is the case of the photovoltaic cells technology. Energy production for its use in the building can help the building sustainable in terms of both energy and environmental factors. Energy production system will be a supportive mechanism to low efficient technology, making the building become a Net-Zero Energy Building.



## Building Envelope

The building envelope is designed to reduce building load. If a window and wall are made of appropriate material and designed in compatible with weather conditions and the building's objectives, the building envelope then creates high energy efficiency, being able to reduce much load of air-conditioning and lighting system. The building envelope plays an important part of setting the energy usage level in buildings. The research on this technology correlates with the development and material usage such as insulator and glass as well as appropriate wall design including wall and glass shaping etc.

## Insulation

The insulation can be installed with a blank wall to reduce heat transfer between the building and environment. In the temperate countries, the insulation is used to protect heat waste passing out of the wall, while in the tropical countries, it will reduce heat transfer from outside which will help the cooling load in the air-conditioning system. At present, there are few studies on insulation usage for the building in the tropical countries. Normally, heat can be reduced through wall passing and it is necessary for the wall to be added with thick insulation. But the thick insulator make building space narrow and inconvenient to be transported, making it widely unacceptable. Part of the research has recently been focused on developing new materials that make thermal conduction at lower U-value and convenient for work. The insulation technology can be classified into traditional insulation, state-of-the-art insulation and possible future insulation.

Nowadays, the insulation application has been variously classified. The research of this type of insulation emphasizes its appropriate application with building walls, potential analysis of energy consumption in the building and the internal rate of return. The research found different situations depending on the weather conditions, communities' context/locations and building use. In some cases the studies show that the misuse of insulation can affect higher energy consumption in the building. Types of insulation under this categories are:

- Fiber glass is in the plate and flat sheet shape, lightweighted. It can be cut or installed with the blank wall or roof, having about 30-40 mW/(m.K) of thermal conduction (U-Value). Since it can preserve humidity, the thermal resistance property will be lost (high thermal conduction).
- Expanded polystyrene and extruded polystyrene have the same thermal conduction as fiber glass.



- Polyurethane has 20-30 mW/(m.K) thermal conduction which is lower than that of fiber glass, but has a disadvantage of being flammable and poison gas.
- Cellulose and cork have thermal conduction ranging from 40-50 mW/(m.K)

The most advanced insulation is grouped as the lowest thermal conduction and is expensive. The research of this technology cover the development of mathematical model; thermal bridge; other properties such as thermal conduction, air leak ageing and humidity, its life cycle and deterioration, quality control, its application with building envelope and the internal rate of return (in the future). It includes the followings;

- Vacuum insulation panel (VIP) comprises the perforated panel structure wrapped by polymer, with the thermal conduction ranging from 3-4 mW/(m.K). Its U-Value is higher if the time cycle is higher too. For example, the thermal conduction would account for 8 mW/(m.K) with 25 operating years. Due to the water diffusion and the building having the same heat resistance value, VIP insulation will be very thin compared to traditional insulation. But, it has disadvantage also in its application that cannot be cut or perforated or adjusted to the required location as other insulation.

- Gas-filled panel (GFP) is the technology similar to VIP but has less thermal conduction performance due to its perforated panel being filled with noble gas to maintain its property on thermal conduction. It cannot be cut nor holed. In conclusion, GFP has, either today or in the future, more inferior properties than other types of insulation.

- Aerogel is an interesting material and very likely to be brought for use in the near future. Although its thermal conduction is 13-14 mW/(m.K), its capital cost is very high. The advantage of this material can be made: for more options such as in opaque, translucent and transparent forms.

- Phase change material (PCM) is not the insulation but can change substance status with the ability to absorb and release heat, hence, can help keep temperature in building. The appropriate phase change depends on local weather conditions, cooling temperature. The PCM has low thermal conduction such as parafin.

Type of insulation being on the research and development with possible high potential in the future can be grouped as follows:

- Vacuum insulation material (VIM) is the material structured with small holes having vacuum inside. Its thermal conduction is 4 mW/(m.K). This material, unlike VIP, can be cut without losing thermal conduction properties.



- Gas insulation material (GIM) has the same structure as VIM but is filled by noble gas inside the hole.

- Nano insulation material (NIM) is a porous structure but much smaller than that of VIM and GIM. There is no need to prevent NIM from air leakage and humidity for its life time which lasts about a hundred year. NIM comprises not more than  $4 \text{ mW}/(\text{m}\cdot\text{K})$  of thermal condition.

- Dynamic insulation material has the property to control thermal conduction as and when required.

In order to drive all the mentioned development towards the real application, it is necessary that such major properties of insulation be considered as strength, load bearing, perforation, life time, installation and price. An indication from the previous studies shows that there is no all-in-one insulation to meet the whole requirement.

The research on applying the insulation with the building wall is also conducted such as the study on the selection for use of insulation available in the market, the research on improving the advanced insulation that is in the market to be more upgraded, and a research on finding the higher efficient insulation materials.

## Glass

The glass window has inevitably affected energy use of the building. Heat transfer between building and the outer environment through windows has a very high rate compared to a blank wall. In the tropical countries, the glass should have low thermal transfer value to in order not to allow heat into the building, while the light transfer value is high, allowing more natural light into the building.

### Current usage of energy efficient glass

- Multi glazing is generally the system with three panes, each of which is filled by inert gas. It is coated with a special metal which can reflect low infrared portion of the solar spectrum. Its thermal transfer value is approximately  $0.5\text{W}/\text{m}^2\cdot\text{k}$ . while the light transfer value is approximately 0.7 and 0.4 respectively, therefore, allowing more into the building.

- Suspended film glazing has several layers of film and polymer that withstand sunlight and put together in the middle of glazing. The inert gas is filled in each cavity of layers. It is thinner than other types of glazing and has low light transfer value, therefore, making the glaze low potential in daylight use.





- Vacuum glazing has two-panes having vacuum filled in between the cavity. It may be coated with radiant substance. It is thinner than other several panes having the same properties.

- Low emissivity coated glazing has low thermal conduction and low radiation.

- Smart window has long been studied over a decade, but just recently been placed in the market. Its properties can be changeable through light transmission.

- Solar cell glazing is the technology that stores solar power can in a transparent glaze silicon coated on the glass surface. However, its thermal conduction is higher than those of several panes glazing.

- Aerogel is a new type of glass. There is only one company trying to produce transparent and translucent glazing from aerogel.

- Gas-filled glazing

Apart from developing glass and coating film, other related component parts have also been undertaken as follows;

- Spacer works as a baffle between each glazing. The research was conducted, trying to make a lower rate of thermal by using foam spacer, thermo plastic spacer or metal-based spacer. The result found that thermal conduction of spacer would be made lower by 17-26 W/m.K while aluminum value would be as high as 200 W/m.K.

- Envelope structure has been tried to be made of non-metals such as using PVC with insulation, resulting in making co-heat thermal condition of window lower than 0.8 W/m<sub>2</sub>.K.

## Building Design and Appropriate Technology

In Thailand, energy consumption in buildings is influenced by various factors which, apart from what earlier mentioned, also include; building design, proportion of blank wall and glazing windows, building model. Properly designed sunshade equipment can create energy potential of the envelope. It can help prevent heat from direct sun radiation, thereby, is able to reduce cooling load. It also allows daylight in the building and makes reduced electricity demand in the lighting system.

In designing the buildings, many factors have to be brought for consideration. Regardless of climate conditions, building feature can be taken into account for the study which found for the tropical countries that buildings with installed insulation walls and air-conditioning



operated at night will consume higher energy than those with the un-installed insulation. This is because heat from the sun radiation that gets into the building during the day time cannot pass out of the building at night time. This means that the design and proper selection of envelope materials need more in-depth and all-side study to ensure its preciseness and reliable results. Besides, cost benefit analysis should be taken into account as part of the research.

The research as such has to rely on analysis tools so as to face with every condition occurring all year round. These tools include EnergyPlus, TRNSYS) and optimization techniques (Genetic Algorithm, the Particle Swarm Algorithm and Sequential Search Algorithm).

## Air-conditioning and Ventilation System

Air conditioning system in buildings prevails in many forms and can be divided into 2 groups: conventional air-conditioning system and alternative air-conditioning system.

### Conventional air-conditioning system

Conventional air-condition is an electrically operated system with vapor compression working as the cooling process. The cooled air which is rotated by air handling unit will then transmit the heat out of the building.

**Research on increasing efficiency of this system involved in improving small parts of procedures in the cooling process to create better performance of entire cooling process by using the following techniques and equipment;**

- Increasing performance in the vapor compression process i.e. use of multi stage compressors with inter-cooling of refrigerant in order that electricity demand can be reduced.
- Increasing performance of heat rejection process of condenser i.e. increasing condenser heat transfer surface and reducing condensing temperature by water or heat ventilation instead of air.
- Using other cooling substances such as CO<sub>2</sub> to replace vapor compression system.

Energy consumption in the air-conditioning system can be reduced not only by the equipment efficiency but also by controlling the system operation appropriately. Part of this research involves the development of cooling performance analysis process under the cooling load and other environments, and controlling the entire equipment operation system.



## Alternative Air- conditioning System

Alternative air-conditioning system being different from the conventional one, uses thermally driven system as an energy source like solar cooling of which a lot of studies have been made.

Another group of alternative air-conditioning uses different concept such as desiccant dehumidification and radiant cooling. The research of this systems also links with thermal comfort.

## Solar Cooling

The system is an alternative air-conditioning technology in buildings operated by using delivered heat from chiller process (both absorption and adsorption). Heat temperature will stipulate types of a chiller and its entire efficiency.

The solar cooling in buildings has such basic equipment as solar collector which is the thermal energy storage performing as the heat storage from solar collectors, and absorption and adsorption chiller to cool water when transferring heat from thermal energy storage at the working temperature.

Currently, industries have applied this technology by using waste heat as an energy source. But when applied with the buildings by using solar radiation as the heat source and with lower temperature, the technology has to be further developed. The research review conducted through solar cooling system covering both experimental research, simulation and modeling to make an analysis on its performance and potential found that the system efficiency is still based on local weather condition and design of various components of the system. Hence, the research covers issues ranging from the development of high efficient equipment technology, design and system control to be suitable for each locality.

Types of solar collectors working in compatible with solar cooling are many. It is found from the research that the flat plate collector and evacuated tube collector in the system need a lot of space (10-12m<sup>2</sup>/Ton), therefore, are suitable for low cooling load as in households. However, it may not be suitable for buildings where there is high cooling load and may need to be operated with conventional air-conditioning. For air cooling demand at night time when heat cannot be generated, solar collectors have to be installed with thermal energy storage. The solar collectors then have to be designed to be big enough for the performance during the non-solar radiation time.

The heating generation system may be in a hybrid, having 2 heat sources; one from solar with gas which need boiler installation, the other from solar with biomass.



## Desiccant Air-conditioning

Desiccant air-conditioning is the method of using sun radiation. Many countries in temperate zone have conducted the research on this technology for use in buildings. The system uses hydrometeor as refrigerant with desiccant, either solid or liquid, to exchange sensible heat and latent heat between two air streams. At the first air stream, the air outside the building will be dehumidified and passed through several steps to reduce temperature before being dispersed into the building, while another air stream (waste air or outside air) will be heated by solar for dehumidification stored in desiccant. This system is suitable for temperate countries with moderate humidity.

For the tropical countries with high humidity, there is a lot of use of energy to make reduced the humidity. However, desiccant can be used for air dehumidification before being transmitted into the buildings. It is expected that there is a potential of desiccant air-conditioning in tropical countries due to a large amount of sun radiation.

## Radiant Cooling

Radiant heating is the method generally found for use in the temperate countries, meanwhile radiant cooling has also increasingly by well recognized. Because it is believed to create more thermal comfort and efficient air-conditioning in building. Heat Transmission of 50% of the radiant process can be applied in this method.

This system is now in the step of research and development that need understanding in its design and control. Since the air-conditioning methodology is different from the normal approach, the study then interrelates with thermal comfort analysis.

## Thermal Comfort

Using energy in building is due partly to make thermal comfort for dwellers. “Thermal comfort” is defined from the research on buildings as the balance of the body without adaptation to the environment or is the condition of mind that express satisfaction with the thermal environment. Thermal comfort has somehow linked with body and mind. It has broad meaning and does not imply to any particular condition nor particular feeling.

Under the same basic environment, warm and cool feeling of human beings vary and not the same as the case of measurement tools. In making analysis on factors or variables effecting the thermal comfort, It is necessary to be relied on the real human beings. As seen



from the past study, 4 physical variables effected the thermal comfort: air temperature, humidity, velocity and mean radiant temperature. The other two factors relate to si.e. clothes wearing and activities.

Energy conservation is to keep thermal comfort in building for dwellers. The past research on this subject covered the mathematical model development and indicator from real experimental areas as well as the development of thermal comfort standard and its assessment.

## Illumination in Buildings

A research work concerning Illumination in building is focused on the lighting electrical system to ensure that it performs up to the standard. The energy proportion used for the system is 20-40% of the total electricity in the building. Selection of appropriate use of the efficient technology and design can reduce more than 50% of electricity demand on the lighting system.

A part from the lighting electrical system, daylight application is another research subject found to relate with accelerating energy efficiency. Daylight use can reduce electricity from artificial lamp by 75% while keeping the same lighting standard.

## Lighting System

Today, efficient lighting devices are available in the market. Taking into consideration the cost for its whole life-cycle, efficient lighting equipment is worthwhile compared to lighting system and method used nowadays.

## Lighting Equipment

At present, more efficient lighting in buildings can be increased. The life-cycle of lighting equipment is shorter than air-conditioning equipment and envelope materials, consequently has a chance to change to higher energy efficient equipment.

Almost all the buildings have installed T8 fluorescent lamps together with magnetic ballast, though T5 lamps with electronic ballast which consumes low electricity by 40% still find available in the market now.



LED bulb development has been dramatically growing. There is a report indicating that LED's efficacy has very high rate of 100lm/W. It is forecasted that by 2035 the major application of bulbs will be changed to LEDs.

Ballast is the electric device connected with bulbs, consuming 10-20% of the current entire lighting system in Europe. As stated in the Ballast Directive 2000/55/EC, the low efficient ballast could sell in the market at the end of 2005, only low-loss ballast and electronic ballast would be allowed.

Light lamp is another equipment that can increase light efficacy in the system and bring the light to the working area. The research and development of this device concluded that efficient light lamp with switching light bulb control can reduce 40% of the total energy consumption of the lighting system.

There are various devices for controlling the lighting system and reducing energy use. In daily life, light bulbs can be turned on at all time even no one nearby uses them. As such, the light bulb switching control has been designed for a variety of purposes, depending on the objectives and opportunity. Timer is a good, simple and easy-to-use device. Intelligent and complicated equipment like remote sensing can make the switch turn on/off automatically. Diming device also helps connect the lighting system with daylight technology. All can find in the market now.

## Design and Its Appropriate Technology

Task lighting system is designed to distinct between light for work and light for beauty. It has been used since the 20<sup>th</sup> century when there was an energy shortage. The design generates the light level of 50-200 lux for usual tasks and of 500 lux for the specific task area. Use of daylight can also help reduce a lot more illumination. Lighting quality however should be concluded as part of the research.

## Daylighting Application

Daylighting has higher light efficacy than artificial light. If it is brought for use in the building, the total energy consumption of the lighting and air-conditioning systems will be reduced.



## Amount of Daylight and Sky Luminance Distribution

In bringing daylight for use in energy conservation in the building, it is necessary to understand the sky conditions and daylight in such locations. In this connection, a daylight measuring station should be established to collect data and study daylight luminance behavior. In 1971, Europe and all over the world promoted the study of daylighting by setting up the International Daylight Measurement Program: IDMP). Now that it is over 20 years, there still remains the effective station providing all important sources of information on daylighting technology development.

The measurement of only daylighting value is not enough for the technological development. The study of sky luminance distribution is the key element of the information base for calculating the amount of daylight in the buildings. Usually, daylight in the building is only part of luminance passing through the sky.

## Daylighting Technology

Daylighting technology is tremendous. Now, its technique and materials are continuously developed. Meanwhile, it is also to understand the daylight features of each location (local daylight and climate) and the building's daylight application before appropriately choosing and designing its technology.

Window and roof aperture are the basic tools to bring daylight for use. But if the daylight is allowed into the building more than necessary, it will affect the energy use in the building as there is more heat coming in.

Shading devices (both inside and outside the building) with suitable shape and sizes can prevent the building from direct sunlight, but still allow sky diffused light into it. Part of the devices can also help reflect or diffuse direct sunlight and prevent glare in the building. Other groups of shading put different emphasis on light refraction from direct sunlight.

Another daylight technology does not use shading devices, but get the light refraction technique to change the direction of outside daylight to be used in the area far from the window or aperture. This technology can be sub-divided in accordance with the feature and daylight input method.



## Water Heating

Hot water is necessary for use in many types of buildings. Generally, water heating in buildings uses various fuels sources such as oil, natural gas, liquefied petroleum gas or electricity. But the study has been specifically focused on developing water heating for buildings through the process of heat pump and solar water heating.

The research on equipment and material technologies relating to solar water heating has been conducted such as solar collectors - flat-plate collectors, evacuated- tube solar collectors, integral collector-storage system, the development of building integrated solar water heater which is expected to reduce capital cost. The development also includes solar water heating system standard, a guideline for installing the system to conform with climate conditions and a system design.





# Research and Development in the field of Energy Conservation in Transport Sector

The energy consumption in transport sector accounts for 37% of the total energy consumption(2), which is due mainly to the reliance of road transport which requires 95% of energy consumption of all transport modes. An assessment on energy efficiency potential in the sector found that with the technology and supportive measures to increase vehicle efficiency and transport system as well as driving behavior, the energy saving would go up to 40% of the total energy consumption in transport sector in 2030 under the business as usual (6). Major high-energy efficient technologies are highlighted in Table 3.



Technologies for accelerating energy efficiency in transport sector	
1. Vehicles	1.1. high-efficient benzene and diesel engine 1.2. hybrid car, plug-in-hybrid and sky train 1.3 high efficient motorcycles and electric bicycles 1.4 technologies supporting eco-driving
2. Rail transport	2.1 mass transit electric rails 2.2 high speed electric trains
3. Water transport	3.1 high efficient motor boats, and electric boats for canals/rivers
4. Transport and traffic system management	4.1 technology supporting transport and traffic management especially intelligent transport system (ITS) 4.2 technology supporting fleet management

Table 3 Technologies for Energy Conservation in Transport Sector (3)



The concept of “A-S-I-F”, which stands for; Avoid (A)commuting, modal shifting (S), improve energy efficiency (I) and fuel switching (F), was brought to study factors and ways to reduce energy consumption and green house gas emission in the transport sector (10 ).

- Avoid commuting (A) means to descend travelling and transport or avoid commuting from motorized mode. The measures supporting the avoidance of travelling and transport can be implemented by “Travel Demand Management-TDM” such as road pricing, odd/even driving bans, compressed work schedule, promoting the use of communication technology and the working-at-home program etc.

- Modal shift (S) means to change modes of travelling and transport to a more energy efficient ones i.e. changing travelling by private vehicles to non-motorized mode or public vehicles, changing goods transport by trucks to rails or water transport etc.

- Improve energy efficiency (I) means to increase energy efficiency technology used in transport and travelling which generally implies as road transport. To improve high energy efficiency in vehicles, it is to promote new vehicle development i.e. hybrid electric vehicles: HEV, and change behavior from driving old vehicles to eco-driving.

- Fuels switching (S) means to change commonly used fossil fuels (benzene and diesel) to a low rate of green house gas emission fuels i.e. natural gas, biofuels etc. or fuels mix. It also means changing energy types used in transport sector from liquid fossil fuels to electricity i.e. electric vehicles: EV.



## Factors effecting energy consumption and green house gas emission in transport sector

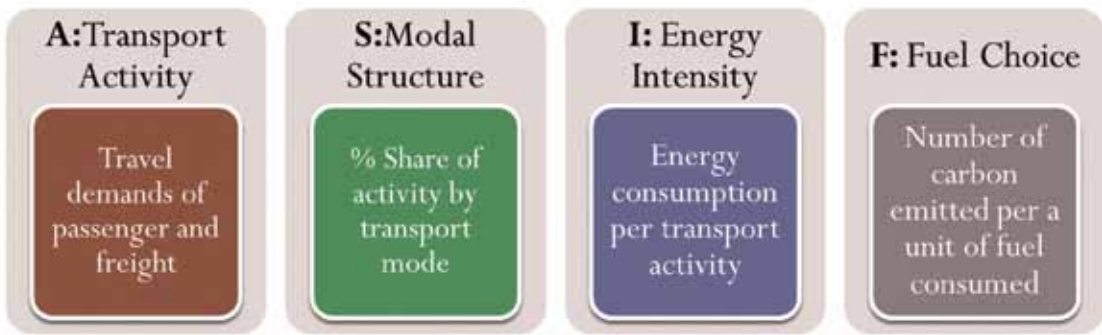

## Approaches for energy saving and green house gas emission reduction in transport sector

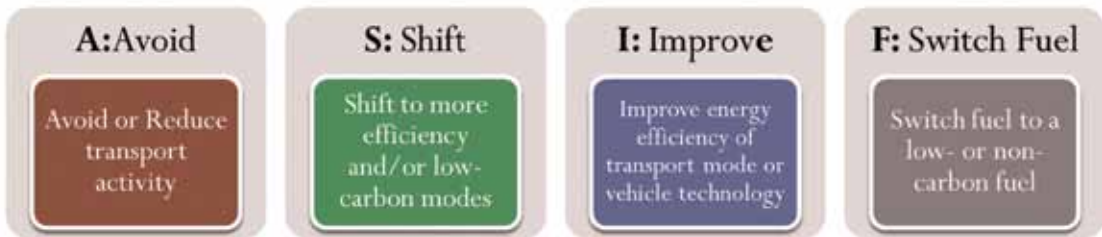

Figure 4 : Factors and Approaches for Energy Consumption Reduction and Amount of Green House Gas Emission in Transport Sector (11)

## Avoidance of Travelling and Transport

The key technology that relates to an avoidance of travelling and transport is an information technology. This technology can be applied together with the measure of traveling demand management or TDM which aims to change traveling behavior of commuters in such a way that energy efficiency in transport sector can be accelerated. TDM consists of 3 measures (1) incentive measure or create more barriers to reduce travelling amount (2) promotional measure on other optional activities to replace the travelling and (3) city planning and land use measure. Each group is described as follows;



- **Incentive measures or accelerating hurdles to reduce travelling**
  - Road pricing in traffic congested areas
  - Limitation of a parking lot or vehicle fee charge at high price in urban areas
  - Vehicle taxation that is aligned with its useful life/year
  - Compulsory measure to enforce vehicles to be used according to license numbers
- **Measures to promote other options to replace traveling and transportation**
  - Encourage the use of information technology to support work without travelling
  - Set up city planning to shorten the travelling i.e. decentralization

The study on formulating the 20 Year Energy Efficiency Development Plan (6) made an analysis on energy efficiency potential of transport sector based on the hypothesis that TDM and city planning could gain energy saving in transport sector approximately 1,010 ktoe in 2030. Overall measures and technologies related to energy conservation for travelling avoidance and energy saving potential in 2030 is shown in Figure 5.

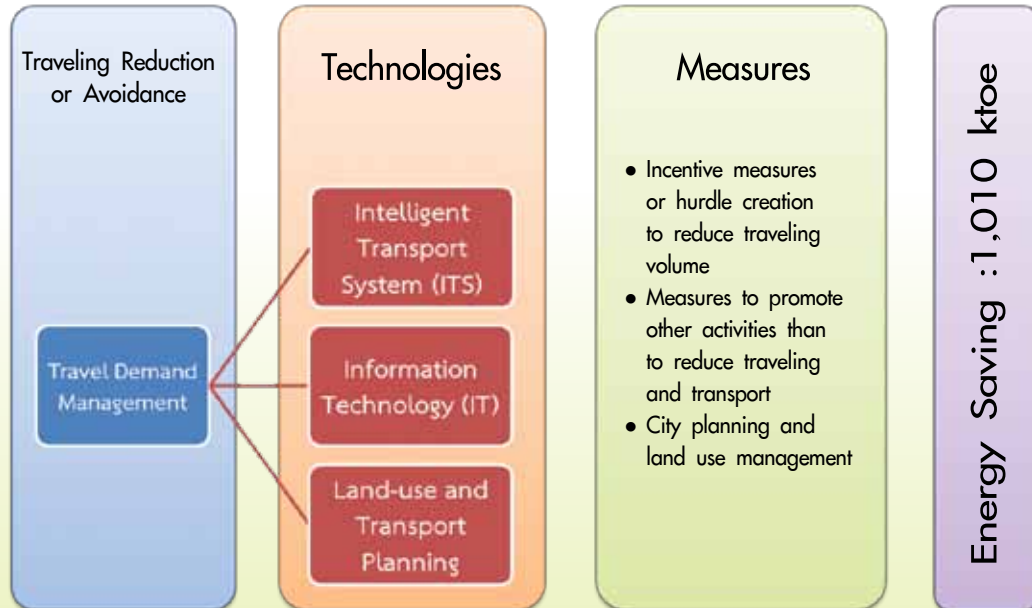

Figure 5 Technologies and Measures for Energy Conservation to avoid travelling in 2030 (11)

## Changing Mode of Travelling and Transport

Public transport has been recognized as one of the most efficient passenger urban transport due mainly to several advantages such as time shortage, transport investment cost reduction, less energy consumption and green house gas emission reduction. Many modes of public transport have been implemented now such as busway, bus rapid transit-BRT, light-rail transit, elevated or subway electric train. Each system efficiency is different in terms of passenger transport and investment of infrastructural systems as well as vehicle technologies. Rail and public transport systems are more efficient than other modes of transport, and are the major systems in big cities in every country nowadays, since they use electricity which is regarded as the most efficient energy use and highest capacity of transporting passengers.

However, establishing transport system infrastructure alone cannot make change of travelling modes. There should be other support mechanisms that help the change. Here it comes to TDM – a tool that helps accelerate the change thorough such several measures as road pricing charge in the congested traffic urban area, restriction of a car parking lot, and high rate fee of car parking in urban areas, park and ride areas, and precise time table information on mass transit system to be published in the website or via mobile phones.

An estimation from the 20 Year EEDP found that, the travelling ratio by the public transit system will be higher if there is an implementation of infrastructural development of mass transit system in the cities in accordance with various plans set by the Office of the Transport and Traffic Policy and Planning, Ministry of Transport i.e. the Study on Urban Rail Transport Master Plan in Bangkok and Surrounding Areas, Bus Rapid Transit System Network Integration Project in Bangkok and Surrounding Areas, including the construction of public rapid transit system in city regions, such as Chiang Mai which is under the Mass Transit System and Design Master Plan. In 2030, with the high travelling rate on mass rapid transit system, the energy consumption can be reduced to 342 ktoe.

Goods transport modal shift is one of the key approach towards energy conservation in transport sector. According to the 20 Year EEDP, an analysis was made on the potential of energy consumption reduction received from changing inter-city mode of goods transport through the TTPPO's action plans such as the Report on the Study on Factors Affecting the Change of Suitable Models of Travelling and Transport by Roads to Rail and Water, the Report on the Development of Multimodal Transport and Logistics Management in Transforming



Plans into Actions. The analysis found that if there is an implementation as planned, the increasing rate of goods transport by rails will be 17% by 2030 resulting in an increase in energy saving by 2,770 ktoe.

Overall Technology and Measures Related to Energy Conservation as a Result of Changing Modes of Goods and Passengers Transport in 2030 is shown in Figure 6

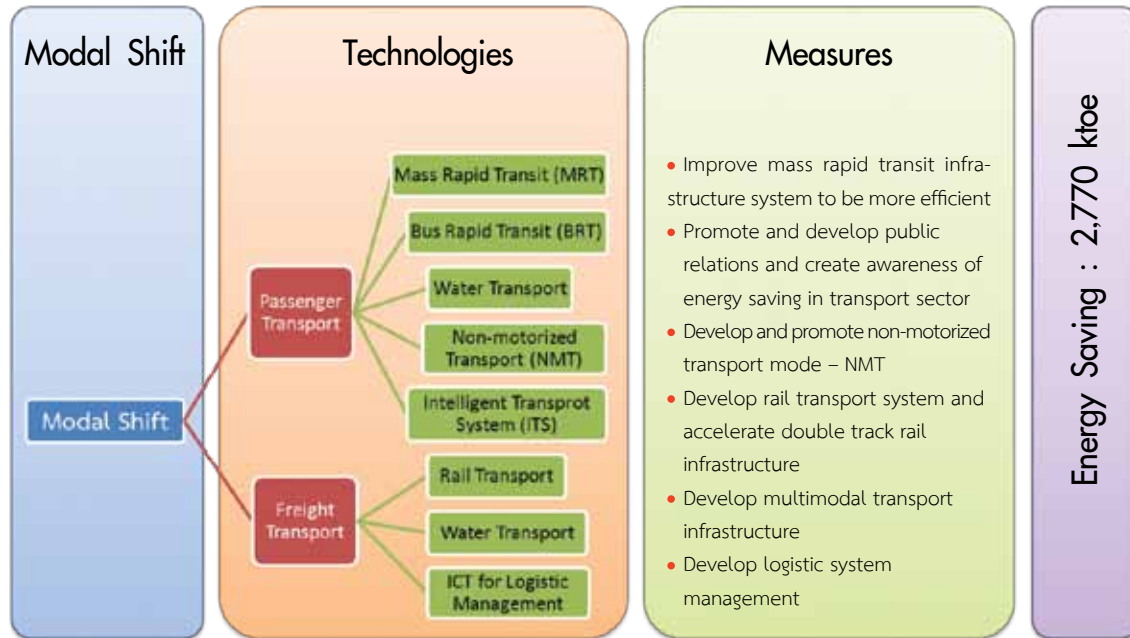

Figure 6 Technologies and Measures for Energy Conservation in Transport Avoidance and the Energy Saving Potential in 2030 (11)

## Energy Efficiency Improvement

There are two groups of technologies/measures related to an acceleration of energy efficiency in vehicles. The first one is the vehicle technology with high energy efficiency being developed to replace the old one. The second one, with the objective to increase energy efficiency in old vehicles within the transport system, will help promote driving behavioral change to eco-driving. Details of technologies and measures as such are as follows;



## New Automobiles

Vehicle technology has now been continuously improved for higher energy efficiency. Emphasis on such development has been made. The first part has been concentrated on reducing factors affecting energy consumption in vehicles i.e. vehicle weight decreasing, developing aerodynamics of the vehicle. The second part has been focused on accelerating advantageous factors for energy consumption i.e. fuel use efficiency improvement through modified transmission system, fuel injection development and changing vehicle engine to higher efficient ones such as hybrid drive and electric drive engines etc.

Such high efficient vehicles as seen at present are eco-cars, hybrid electric vehicles, plug-in hybrid electric vehicles and electric vehicles. The measures to promote these types of vehicles can be classified into 2 options. The first one is the promotional measures and information provision i.e. car labeling promotion. The second one is high efficient labeling standard measure on energy performance in vehicles i.e. minimum energy performance standards (MEPS).

Car labeling is an essential tool of high energy efficiency policy in transport sector that can provide information on fuel economy (CO<sub>2</sub> emission reduction) for consumers for their optimal choices of purchasing.

MEPS is another important standard measure being used by many developed countries to increase energy efficiency in new groups of automobiles. However, different countries have different parameter of efficiency and standard test measures and also different in their enforcement. Efficiency parameter has two characteristics - fuel economy and emission. They have been used by countries differently i.e. U.S, CAFÉ, EU-NEDC, Japan 10-15 etc. The enforcement as such with automobile companies of each country is also varied, either mandatorily or voluntarily.

An essential hypothesis was evaluated on energy conservation potential to be accelerated in new automobiles under the study of 20 Year EEDP included 1) over all types of existing vehicles in the country – private cars, private vans, regular and non-regular buses, trucks 2) fuel economy of current vehicles and future change (that might refer to Japan's fuel economy). Based on this hypothesis, fuel economy would be better improved by 20% in 2030, electric bikes would be increasingly distributed by 70 of the total new motor bikes in 2030 which would make it increased by 60% of the total motor bikes in the same year or



equivalent to those currently available in China – the Country that has the highest rate of motor bikes used in the world. The analysis showed that the related technologies and measures would result in the energy consumption reduction in transport sector by 8,420 ktoe. in 2030.

## Existing Automobiles in Transport Sector

Changing driving behavior to eco-driving can be a method to encourage energy efficiency in transport sector. This can be conducted through; driving with smooth acceleration and deceleration speed, appropriate and stable velocity while driving, turn the engine off while parking, as well as regular engine and vehicle maintenance i.e. tire checking with appropriate air pressure etc.

At present, technologies can even further help change driving behavior to eco-driving through the supporting equipment that inspects and assesses technical information of automobiles to calculate driving efficiency and show the date to drivers so that they can automatically change to the eco-driving conditions. Such equipment is; eco-driving monitoring technology, speed limit, idling stop equipment. They collect technical information of vehicles through data logger and computerized system indicating the energy efficiency while driving. They can be installed in all types of vehicles, either private cars, trucks or buses and can help check the drivers' behavior and reduce energy cost in companies accordingly.

The 20 Year EEDP assessed the energy conservation potential in the transport sector by accelerating energy efficiency in 5 types of existing vehicles, taking them for the implementation of the measures stated in the previous paragraph. The same assessment was also done with the new types of vehicles based on an essential hypothesis that eco-driving will result in increasing 10% energy efficiency in vehicles (IEA study is about 5-10% (11)). These technologies and measures can, help reduce energy consumption in transport sector to 4,050 ktoe. in 2030.





Overall Technology and Measures Related to Energy Conservation as a Result of energy efficiency improvement in vehicles and energy saving potential in 2030 is shown in Figure 7

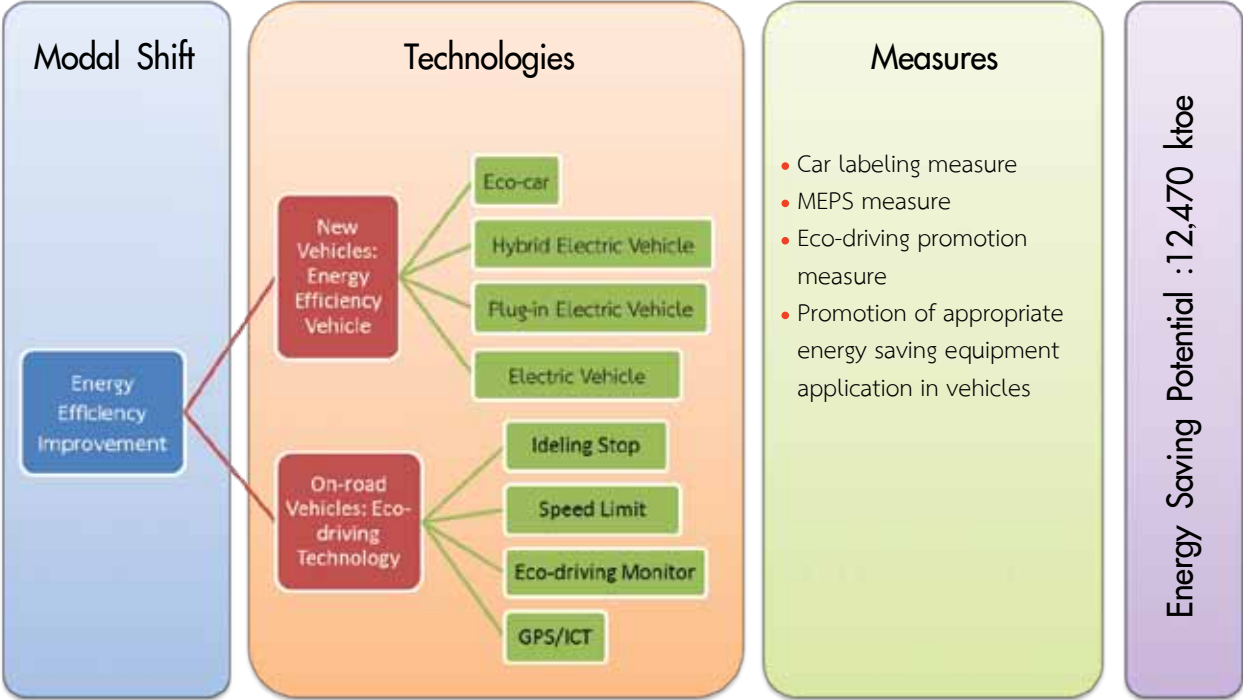

Figure 7 Technologies and Measures for Energy Conservation in Transport Avoidance and the Energy Saving Potential in 2030 (11)



# Research and Development in the field of Renewable Energy







## Research and Development in the field of Renewable Energies

From a review of 1,406 pieces of research on renewable energies between 1996 – 2012, it is discovered that during the past 15 years in Thailand researches are focused on 5 renewable technologies, namely solar, ethanol, bio-diesel, biomass, and biogas. There are 1,311 pieces of research on these 5 technologies, accounting for over 90% of all the research reviewed. Among them research on solar has the highest share, accounting for 30%, followed by ethanol for 22%, bio-diesel for 20%, biomass for 12%, and biogas for 9.5% as shown in Figure 8.

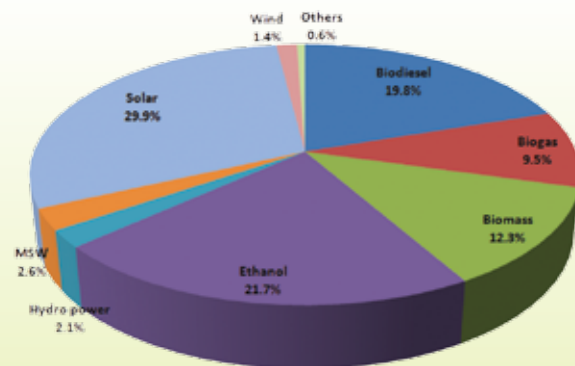

Figure 8 Share of Research on Renewable Energy Technologies Conducted Between 1996-2012



**Figure 9** presents the number of research per renewable energy technology. From the analysis, it is discovered that each technology requires different expertise. When the main 5 renewable energy technologies, namely solar, ethanol, bio-diesel, biomass, and biogas are considered, the institutions which have the top-two highest shares of number of research for each technology are as followed.

- **Solar** : King Mongkut’s University of Technology Thonburi (KMUTT) and Naresuan University (NU) have by far the higher share of research on solar technology than other institutions, since they have their own specific laboratories and experienced researchers. The 2 institutions conducted 268 pieces of research (144 by KMUTT and 124 by NU), accounting for 67% of all research. Chulalongkorn University is the institution which produced the third highest number of research, accounting for 11% of all research on solar technology.

- **Ethanol** : Chulalongkorn University is the most prominent institution with regard to research on ethanol. The University has conducted 119 pieces of research, accounting for 39% of all research on ethanol. The institution with the second highest number of research is Khon Kaen University which is an institution with close proximity to the planting areas of energy crops for ethanol production, including sugar cane and cassava. Khon Kaen University conducted 24% of all research on ethanol (74 pieces of research), while Chiang Mai University accounts for 15% (46 pieces of research).

- **Bio-diesel** : The source of primary raw material for bio-diesel is, for example, palm oil which is located in the South of Thailand. Prince of Songkla University is the most prominent institution with research on bio-diesel. From the review, Prince of Songkla University has conducted 81 pieces of research, or 29% of all research on bio-diesel. Other prominent institutions include Chulalongkorn University and Kasetsart University, with 53 and 34 pieces of research, accounting for 19% and 12% of all research on bio-diesel respectively.

- **Biomass** : It is discovered from the research review that the research on biomass technology is scattered in institutions across regions, with no institution particularly prominent. Nevertheless, the 4 institutions with a number of research around 30-32 pieces include King Mongkut’s University of Technology Thonburi, Naresuan University, Kasetsart University, and Chulalongkorn University.

- **Biogas** : Chiang Mai University is the institution with the highest number of research related to biogas technology, as there is a dedicated biogas research body in the University. There has been 39 pieces of research conducted (accounting for 29% of the 134 pieces of research conducted on biogas). Other prominent institutions include Kasetsart University and Mongkut’s University of Technology Thonburi with 21 and 17 pieces of research respectively.



### Shares of Research on Renewable Technologies

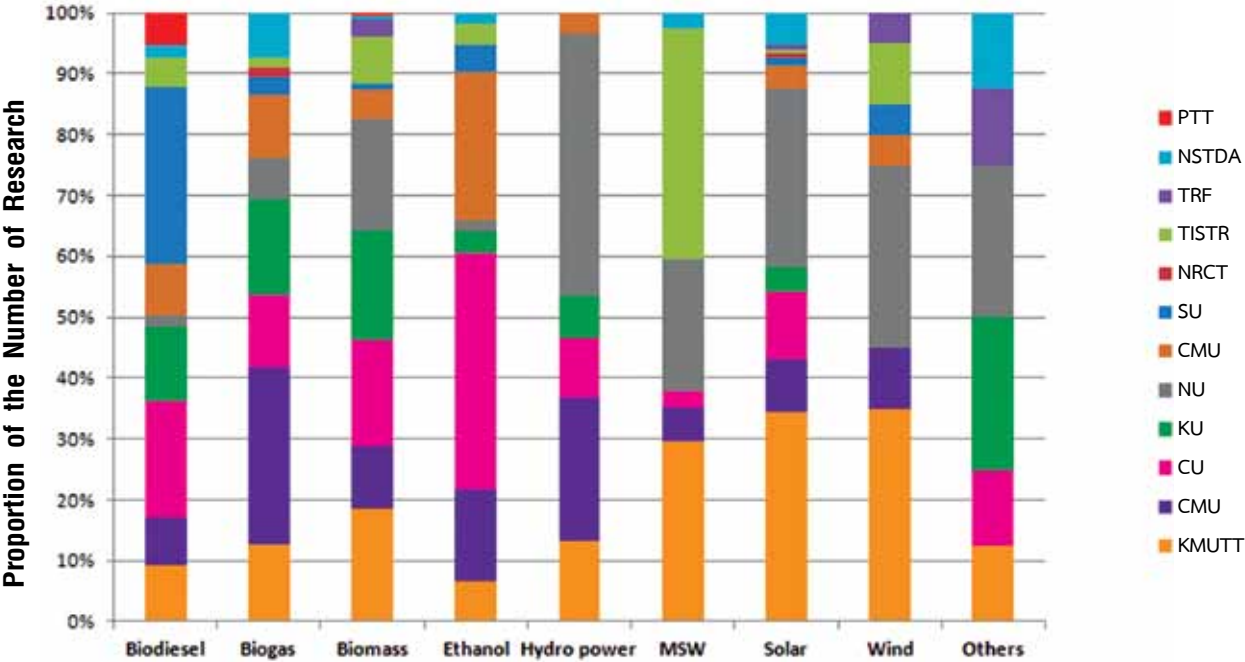

Figure 9 Shares of Research on Renewable Technologies by Institutions





## Solar Energy And Related Technologies

### Solar Cell Technology

Between 1980 – late 2009, there was an installation of solar cell system with the accumulated capacity of 40  $WM_p$  in Thailand. Nearly 70% of this capacity is off-grid systems, almost all of which were installed with government budget. A rapid expansion of solar technology was brought about by a project to provide electricity with Solar Home Systems (SHS) for households in remote areas not connected to electricity grid. The country's overall solar capacity was increased over 26  $WM_p$ . The project also contributed to the expansion of solar cell market in Thailand. However, there was a lack of clear policy in terms of short-term and long-term action plans. There was also a lack of continuity of government support. As a result, the solar cell market in Thailand has not yet grown large enough, with only 11- $WM_p$  grid-connected systems (this includes rooftop installation and solar farms). Moreover, in 2007, the Ministry of Energy announced the 15-year Alternative Energy Development Plan (2008-2022) plus the measures to set up “A dder” and revise rules and regulations on power purchase of the Electricity distributors, and the measures on investment promotions and incentives of the Thailand Board of Investment, this has led to a considerable increase in the number of request for solar farm construction (with an expression of intent to sell electricity of around 2,341  $MW_p$  as of March 2010, which is higher than the 15-year Plan target of 500  $MW_p$ ).



The consideration and analysis of solar cell technology can be divided into 2 parts, namely solar cell technology and the solar cell system technology.

## Technologies and Status of Research on Solar Cell Efficiency

Of all the solar cell technology, crystalline silicon solar cell technology is still the most efficient when compared to thin film technology, not including concentrator type. See Figure 10.

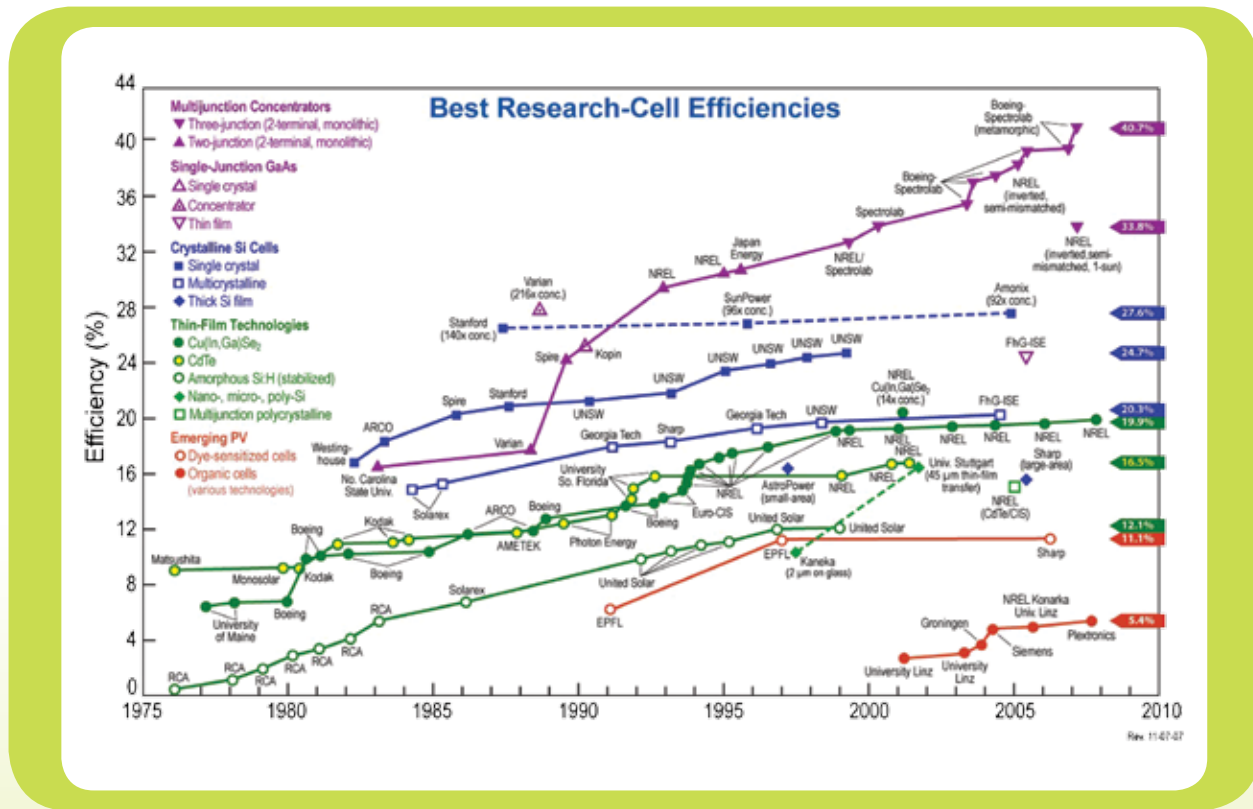

Figure 10 Technologies and Status of Research on the Efficiency of Solar Cell





**Status of solar cell technology:** there are 5 groups of solar technologies as presented in Figure 2.

**1. Crystalline silicon technology** (c-Si or wafer based c-Si) includes single or mono crystalline (sc-Si) silicon, and multi or poly crystalline silicon (mc-Si). The sc-Si has conversion efficiency of around 14-20%, and mc-Si of 13-15%. This technology currently has a market share in commercial production of around 85-90%.

**2. Thin film technology** includes (a) amorphous silicon (a-Si) and micromorph silicon (a-Si/c-Si) with conversion efficiency of around 6-9%, (b) Cadmium-Telluride (CdTe) with conversion efficiency of around 9-11%, and (c) Copper-Indium-Diselenide (CIS) and Copper-Indium-Gallium-Diselenide (CIGS) with conversion efficiency of around 10-12% which accounts for a combined market share of 10-15%.

**3. Emerging technology** includes advanced thin films and organic cells. The prototypes of these technologies are being developed for operation testing, but has not been widely used for commercial purpose. installation, such as dye-sensitized solar cells.

**4. Concentrator technology (CPV)** uses optical concentrator system together with small high-efficiency cell. These technologies are under development and being tested overseas. They are expensive and have to be used with solar tracking system. These technologies are suitable for areas with a high level of average daily solar direct radiation.

**5. Novel PV concept** is the research on highly efficient solar cell technology or new materials. The research is still in fundamental stage, such as Quantum Dot, Thermo-photovoltaic, and Intermediate band gaps.

As for the trend in global market share, crystalline silicon technology still has the largest market share. However, the thin film technology has a rapid technological development and is likely to gain more market share quickly, depending on the improved longevity, costs, and efficiency.



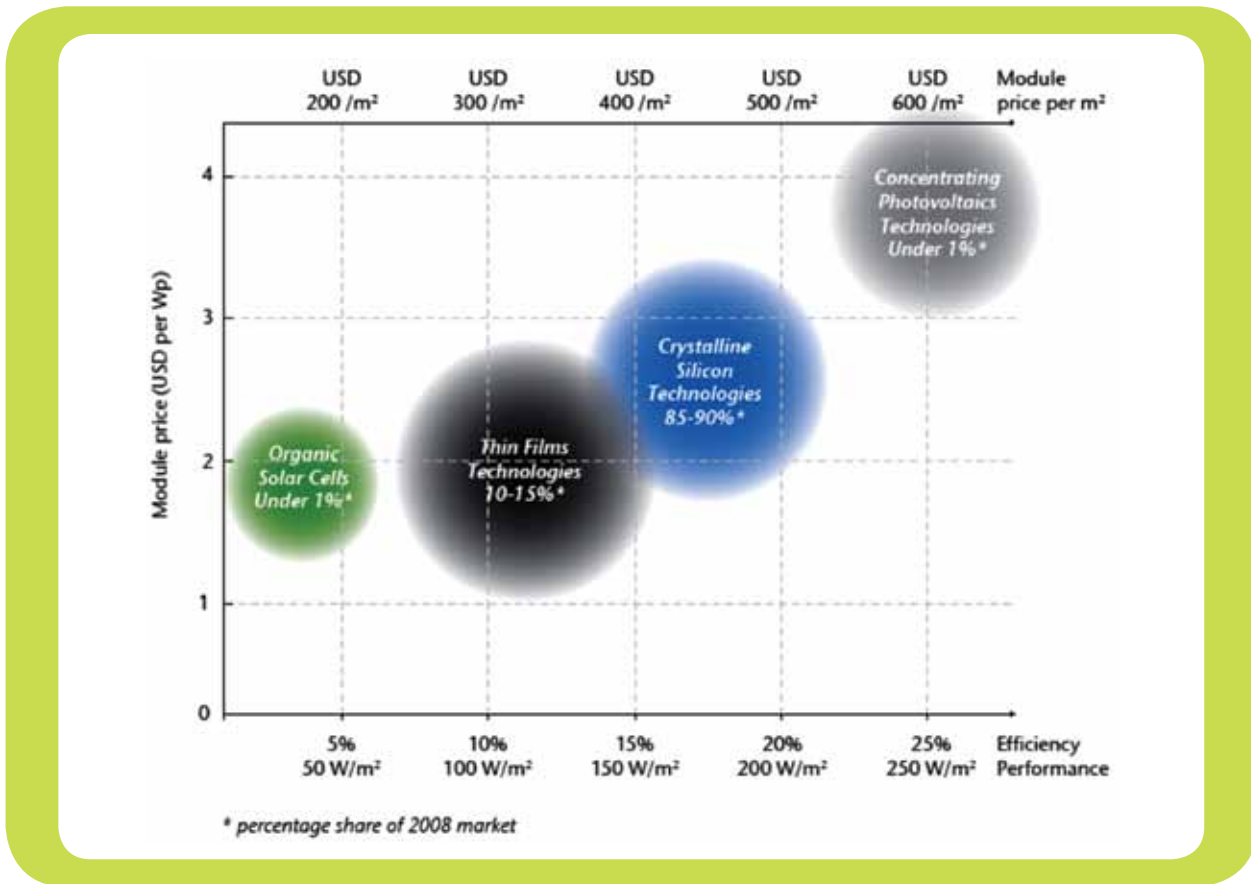

Figure 11 Efficiency of Solar Cells Compared to Price as of 2008 [15]

## Research and Development in the field of Solar Cell Technology in Thailand

For the technologies group (1) and (2) which are commercially viable, the research and development are in industrial level with the aim to reduce production costs (materials and process), to improve efficiency, and to develop quality, durability, and longevity.

- **Technology group (1)** : this technology has long been commercially available, with established confidence in its quality. As a result, there are limited development gaps among countries. There are rooms for development in cost reduction and quality improvement in the industrial production process.

- **Technology group (2)** : thin films Si has been produced and developed to some extent in Thailand. Nevertheless, there remains considerable gaps for development choices. As for CdTe and CIS/CIGS, they are technologies which deserve interest. CdTe is likely to be the technology with the lowest cost per Watt at present. But there are a limited number of producers and Thailand lacks dedicated researchers on this technology (there may be some institutions giving interests in research on materials, but not in solar cell development).

CIS/CIGS are cited in the articles of researchers or in the industrial circle as a low-cost technology comparable to CdTe. The industrial production process in Thailand is also comparable to that of the crystalline silicon technology. There are some Thai educational and research institutions who follow this technology. Nevertheless, a gap of 10-20 years exists in terms of technological development for Thailand to compete industrially with international producers (there is a huge difference in the academic capability from industrial competitiveness).

- **Technology group (3)** still requires prototype development and demonstration of solar cells. There should be a close monitoring of this technology so that Thai researchers can stay current and informed about the choices of technology in the future.

- **Technology group (4)** may have been tested and demonstrated. However, there are obstacles in terms of costs, technological complexity and the pattern of solar radiation in most areas of Thailand.

- **Technology group (5)** is the group which deserves to be promoted so that Thai researchers develop their knowledge and stay current with the international progress. There are institutions which have sound basic knowledge and are up-to-date with the technology.

Considering the research and development infrastructure for solar cell technology and the industrial development in Thailand, it is founded that technology group (1) Crystalline silicon and group (2) silicon thin film have the highest technological potential for industrial development both in terms of efficiency and production process improvement. This may help lowering the production cost of solar cell, increasing the efficiency of cells and cell systems, and improving longevity. On the other hand, considering the fierce global commercial competition from producers in China, India, or Western producers who have established production bases in neighboring countries such as Malaysia, it is essential to consider the potential in terms of investment, and commercial and cost competitiveness. This means that support is required not only in the research and development of technology, but also the development in industrial investment and marketing both locally and internationally.

On the other hand, the technology group (2) non-silicon thin film, such as CdTe and CIS/CIGS, is still not industrially deployed in Thailand. There is also no industrial-orientated research and development, with only research in some institutions' laboratory. Whereas technology group (3) emerging technology, such as dye sensitized, begins to have laboratory-level research and to build some prototypes of solar cells and solar cell system. But 10-15 years of development is still needed for deployment in industrial production. Thailand needs to undertake research and development to stay current with technology group (2) non-silicon and emerging technology, and to participate in setting industrial standards to ensure fairness in access to technology and to protect domestic consumers. This will also help prepare Thailand to adopt new technology which will be produced and deployed domestically in the near future (it should be less than 10 years for foreign technology), depending on the investment policy and incentives.



## Solar Cell System Technology

The solar cell system has been dramatically deployed in Thailand, including solar battery charging station (SBSC), solar system for IT system, stand alone PV systems, solar home systems (SHS), PV grid connected systems in forms of rooftop building integrated PV systems and PV power plants. According to the IEA-PVPS report, solar systems can be divided into 4 groups, namely off-grid domestic systems, off-grid non-domestic systems, on-grid distributed systems, and on-grid centralized systems.

Considering the power producing technologies with solar cell, solar system technology in Thailand in the past focused on off-grid technologies. The main equipment for the solar systems (apart from PV) consists of battery charge controller, maximum power point tracking charge controller (MPPT), and stand-alone inverter. Later on, hybrid electricity-generating systems were developed, alongside mini grid systems and inter-system communication for PV systems located in remote areas.

Now with a more clear policy on electricity purchasing from solar systems, there is an increase of development and deployment of grid-connected inverters, consisting of inverters for small distributed generation (DG) systems with capacity from lower than 5kVA up to 30kVA, and those for centralized systems or PV power plants with the capacity from 100 kVA to MVA. Thai entrepreneurs are now able to develop more advanced products. But further development is still required in terms of efficiency, size, and longevity, as well as systems to prevent affected grid distribution, and a study to reduce the impacts on stability and security of the grid system. Moreover, there should also be a development of energy storage technology for power generation, as well as PV Digital Surface Models (DSM).

## Research and Development on Solar System Technology in Thailand

Thailand's electronic industry has a strong competitiveness and a firm ability in research and development of equipment (balance of systems), both off-grid and on-grid. Still, there have been a limited number of entrepreneurs in the solar system business. Therefore, the new entrepreneurs will require some time to develop technology and to establish confidence of their products. Those entrepreneurs who have continued the business for some time are able to develop their products and gain acceptance both locally and abroad,



With the solar policy support from the Thai government and foreign countries, these policies have brought about a rapid growth of on-grid solar systems in the form of megawatt-level power plants, and an increasing deployment of 100s-kVA on-grid inverters. The equipment is also required to be manufactured in a manner that meets the standards of the Metropolitan Electricity Authority.

Apart from the development of equipment for solar systems, Thai researchers also have the capacity and the commitment to undertake research on solar system technology, such as research on the impact of connecting solar systems to power grid, the engineering design of solar systems, standards testing for solar products and systems. Research on these subjects will need to be undertaken over time. The status of solar technology is demonstrated in Figure 12.

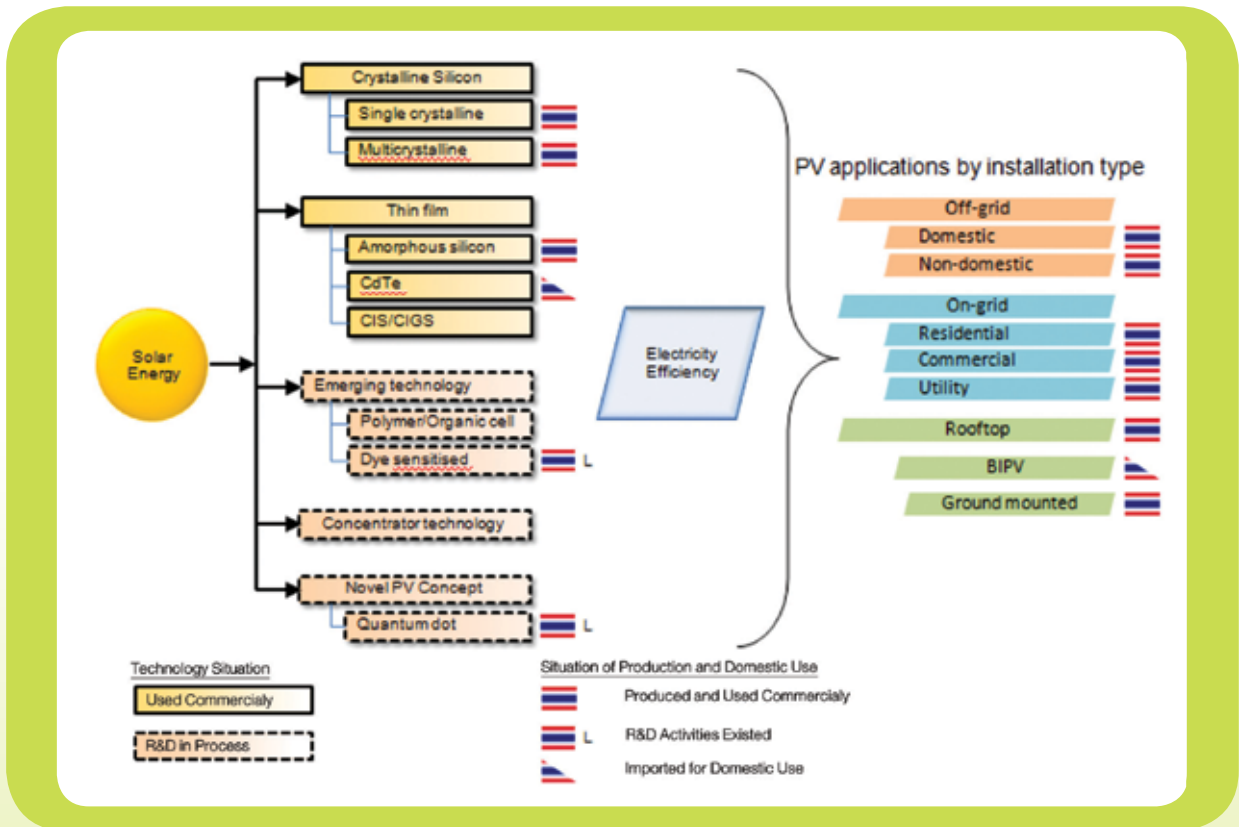

Figure 12 Status of Power Generating Technology With Solar Cells



## Solar Water Heating Technologies

Solar water heating technologies consist of 2 parts, namely solar collector and hot water tank. The design of solar water heating system depends on the user's purpose and requirement. There are thermo-siphon systems (the so-called passive system) which receive heat directly from the free-flow of heat transfer fluids with no requirement for a water pump, making it suitable for households. There is also an indirect water heating technology which uses fluids to carry heat from the solar collector and heat the water through a heat transfer system. This system has many advantages, but it is more expensive than the first technology. In some cases, water pumps are required to assist with the flow of the fluids. This technology is also called an active system which is used for a large water heating system such as in hotels or hospitals. The Ministry of Energy has launched a project to promote the installation of hybrid solar system with heat recovery. In 2008, there was an installation of 3,972 m<sup>2</sup>, worth 21.64 million baht. In 2009, there was an additional installation of 3,000 m<sup>2</sup>, worth 14.14 million baht. Most of the installations were for hospitals, hotels, factories, and academic institutions.

The key obstacle was the lack of standards of the solar panels. In general, there are 2 sizes of solar panel, one is smaller than 6 m<sup>2</sup> and the other is larger than 6 m<sup>2</sup>. At present, there are more than 10 importers, producers and sellers of solar water heating systems. Electricity Generating Authority of Thailand sells systems made with domestic materials. The market for solar collectors for buildings includes hotels, restaurants, hospitals/clinics, hair salons, department stores, laundrettes, government buildings, and prisons. It is discovered that over 80% of households and buildings in Thailand use electric water heaters. Therefore, unless other wise strongly promoted, the share of solar collectors can be higher than 50%.

Solar collector is not a complicated technology. It uses the principle of heat absorption and transfer the heat to water or to other types of heat transfer fluids. At present, solar collector, technology can be divided into 4 categories. The current status of the solar collector technologies is presented in Table 4, and the current status of low-temperature solar water heating technology in Figure 13.



Table 4 Current Status of Solar Collector Technology

Technology	Status	
	International	Thailand
Flat plate collector Efficiency: 30-64% Temperature: 50-70 °C	Commonly deployed	Commonly deployed with domestic production
Evacuated (tube and flat plate) collector Efficiency: 58-77% Temperature: 70-100 °C	Commonly deployed	Commonly deployed with domestic production
CPC type collector (Stationary concentrator) Efficiency: 40-68% Temperature: 70-100 °C	Commercially produced but not commonly deployed	No deployment
Parabolic through collector Efficiency: 67-72% Temperature: 100-250 °C	Commercially produced but not commonly deployed	No deployment



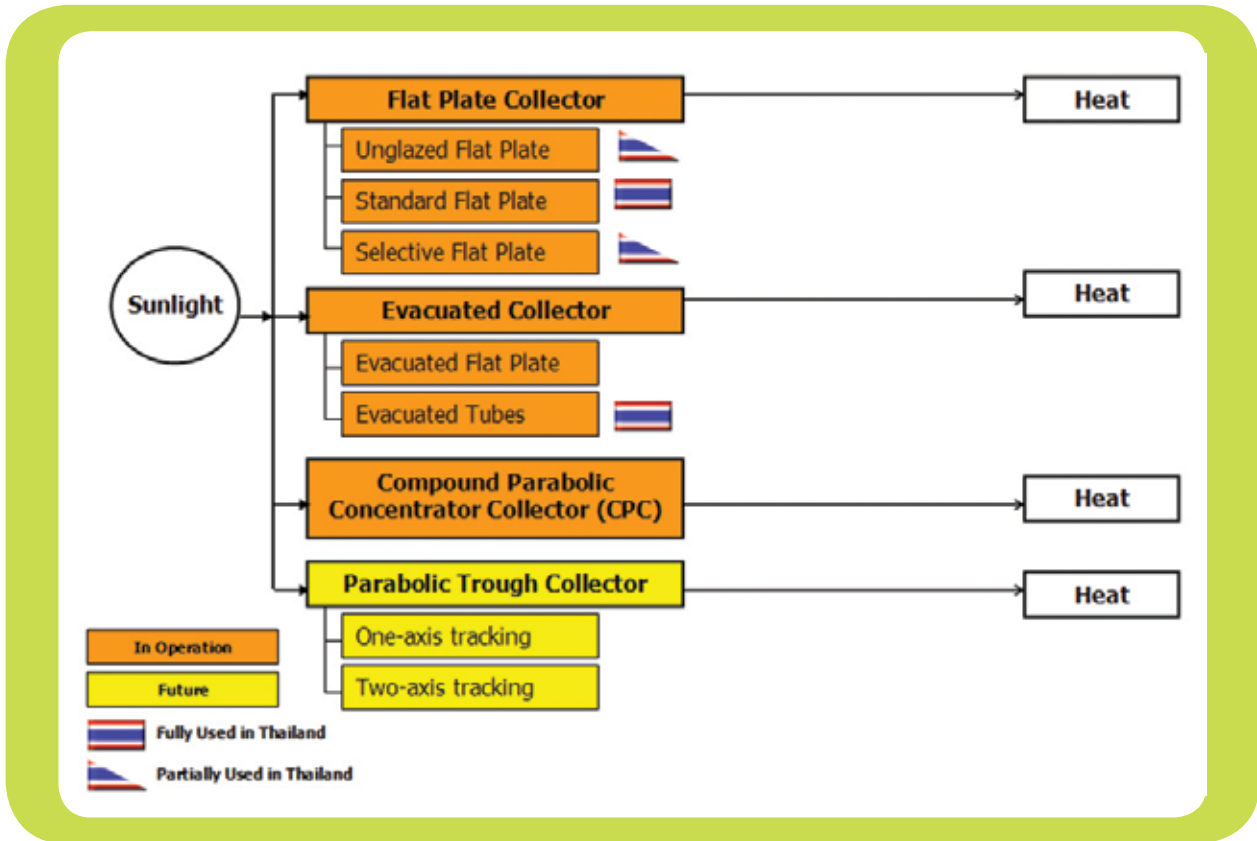

Figure 13 Status of Low-Temperature Solar Water Heating Technology

- **Flat plate collector** is an inexpensive, durable, and easy-to-produce technology. It can be produced domestically. However, it requires a large space for installation. It has a low efficiency and can only heat water to a limited level of temperature. It has a problem of steam condensate, causing collective moisture underneath the glass and mold.

- **Evacuated collector** is a technology that requires a small space for installation. It has a high level of efficiency and a high cost of production and installation. Currently, there is no domestic production. The vacuum tube is more fragile than the flat plate type and needs careful transportation and installation.

- **CPC collector (stationary concentrator)** is a technology that requires a small space for installation. It can generate a high level of temperature without having to readjust the panel's angle towards the sun. However, it is expensive, with limited number of producers and not commonly deployed.

- **Parabolic trough collector** is a technology that can produce a high level of temperature. The panel has 2 axes for sun-tracking rotation, allowing it to produce temperature up to 400 °C.



It is suitable for deployment in solar cooling and process heat systems. However, it is expensive and requires a control system to track the sun. It also requires more maintenance than other technology.

## Research and Development on Solar Cell Technology in Thailand

Flat plate and evacuated tube solar collectors are widely used in Thailand. Both technologies are durable, efficient, similarly priced. Most of them are imported. Only flat plate collector is produced domestically. At present, a super selective coating substance for solar panel has been developed to increase the efficiency and temperature to be the same as that of the evacuated collector. However, this makes the cost of flat plate collector more expensive. Unglazed flat plate collector is cheap and easy to install. Even though it can only produce a low level of temperature (around 50 °C), flat plate collector can produce warm water for pre-heat boiler, which is very efficient for industries that require relatively low temperature hot water in large quantity. This technology has been currently imported but not commonly deployed in Thailand. The domestic production by EGAT and other producers is of a lower cost compared to the imported collectors, but with lower efficiency. Moreover, Thai producers do not give priority to research and development. Thus, the quality of their products has not improved despite having been in production for a long time.

For the next 10-20 years, Thailand will promote solar water heating hybrid with heat recovery systems. Using electricity to produce hot water should not be suitable. The alternatives for hot water production are solar energy and waste heat, such as heat recovery ventilation from air conditioners, coolers and exhaust chimneys. As for hotels, hospitals, commercial buildings and factories, hybrid solar system with heat recovery can be used as these buildings use air conditioning systems, coolers, kilns, steam boilers which generate a large quantity of waste heat. Such hybrid and recovery systems can help reduce the waste of fuels and electricity. Most importantly, these systems use renewable energy and recover waste energy for better uses. In Thailand, the Ministry of Energy has been supporting the use of these systems since 2007 for the installation of hybrid solar water heating systems and heat recovery until 2022, with the target to cover 300,000 m<sup>2</sup> of installing water heating systems.





## Wind Power and Related Technologies

There are several agencies in Thailand, such as Electricity Generating Authority of Thailand (EGAT), Department of Alternative Energy Development and Efficiency (DEDE), and other agencies have conducted research on the use of wind turbines to generate electricity. Most of the works involve using secondary data to calculate and evaluate projects using statistical methodology. Moreover, EGAT has a pilot wind turbine project at Laem Phrom Thep, Phuket with 150-kW Nordtank wind turbines, model NTK 150/25. From the field visit of the Energy for Environment Foundation, it is found that the project's capacity factor is 14%, with an investment cost of around 82.3 million Baht per MW. Other costs include maintenance cost of 1.67 Baht per unit, electricity generation cost of 9.44 Baht per unit. These costs are high when compared to the power production with fossil fuels. These results are similar to the outcome of the feasibility study of using wind energy to produce electricity in the case of wind farm project on Pha-Ngan Island, Surat Thani [17]. From the financial and economic feasibility of the case study, it is found that the wind farm project is not financially feasible, with a negative NPV and a B/C ratio of less than 1.



Apart from the projects mentioned above, there has been a private proposal for Thailand First Wind Farm by Fellow Engineering Co., Ltd. to construct a 360 MW wind farm, whose capacity is equivalent to a 42.11 MW small power producer (SPP) of fossil fuel power plant, operating at 90% load factor. The wind farm is proposed to be located along the coastline from Pak Phanang, Nakhon Si Thammarat to Singhanakhon, Songkhla.

Wind turbine technology can be divided into 2 groups, namely (1) design technology and power control system for wind turbine, and (2) technology for producing wind turbine.

## Design Technology and Power Control System for Wind Turbine

In the past, the airfoil design for wind turbine blade usually used the standard airfoil selection developed by agencies such as NACA or NASA. However, these airfoil sections were designed for aircraft wings, which are different from the airfoil section for blade which has more different specific requirements than aircraft wings. The length of a turbine blade is likely to have a Reynolds Number lower than that of an aircraft wing. Airfoil section is usually resized to be thicker, causing it to lose certain aerodynamic quality. The design of a turbine blade requires individualistic quality of airfoil section, depending on the design of rotor, control system, and other equipment used with the turbine blades.

## Power Control System Technology for Wind Turbine

There are 2 modern designs of power control system for wind turbines with the capacity at MWs level, namely (1) pitch control, and (2) stall control. Both systems have the same purpose which is to reduce the aero dynamic force on the wind turbine when the wind velocity is at a level higher than what the turbine designed for. This will help limit the power produced and protect the structure of the blade from damages. Moreover, under a high wind velocity environment, the system will prevent the power not to be transmitted to the generator more than what it is designed for.

## Technology for Producing Wind Turbine

During the recent years, there is the production of large wind turbines with diameter no less than 80 meters. There has also been a construction of several wind turbine prototypes with diameter 100-120 meters. Over 50 million kilograms of composite materials have been used to produce wind turbines across the world.



As there is a rapid growth of wind turbine, there has been a large quantity of technical research on composite materials and the future trend of this technology, especially on the design of large wind turbines with power production capacity at MWs level.

At present, a large number of wind turbine producers have their own factories. So there is a diversity in the demand for materials and production process. Nordex and GE Wind have built 40-50 m wind turbines using fiber glass in the manual layering process in an open mold and coat a resin based material onto the fiber. NEG Micron is producing 40 m wind turbines using carbon fiber, wood fiber, and epoxy-based material. Vestas has long used prepreg system, using fiber glass as reinforcing material. TPI Composites is producing 30 m wind turbines using vacuum-assisted resin transfer molding (VARTM). Moreover, Bonus uses infusion techniques in making the whole of turbine blades in a single process to reduce gluing between subcomponents in later stage. The wind turbine design technology in Thailand can currently operate at 250 kW level. The experience in producing wind turbines is at 50 kW level.

## Gearbox Technology

Gearbox is an equipment that transfers power from wind turbines to generator and adjust the rotation speed of wind turbine to be at a level needed by the generator (increasing the rotation speed). From previous experience, it is found that wind turbine had to cease operation often due to problems with the gearbox. This is because producers lacked understanding about the nature of wind load on the turbine, as well as about other components such as the material used to produce cogs, lubricant, and the appropriate types of bearing.

In the past 2 decades, wind turbine producers have cooperated with cog designers, bearing producers, and lubricant experts in doing research and development to improve load prediction for the gear, as well as in designing the production process of gearbox. They have achieved a design of gearbox that can last for 20 years. Moreover, there has been cooperation with other engineering agencies on setting the standards for gearbox design of wind turbine. The objective is to get a gearbox that only requires moderate maintenance. Nevertheless, the damages that occur to wind turbine is still mainly to do with gearbox. It is still the primary reason for downtime of wind turbines. Moreover, there are also other expenses to do with maintenance and reduction in power production. The losses caused by a gearbox accounts for 15-20% of the overall cost of a wind turbine.

In 2007, the National Renewable Energy Laboratory (NREL) which is an agency under the U.S. Department of Energy set up the gearbox reliability collaborative (GRC) project. It has a budget support of \$US 2.5 million to find the causes for damages to gearbox. This project has been ongoing for several years and in 2010 GRE world request for an additional \$US 2.5 million to finish the project.



Moreover, in order to ensure that a gearbox meets the standards required prior to installing it onto a wind turbine, the gearbox will be tested at full power. It will then be monitored for vibration and noise during operation, as well as the temperature of its lubricant and the working of the gear's cogs in order to confirm that the design standards are met. At present there is no production of a gearbox for wind turbine. There are only factories that assemble the gearbox with imported parts for other industries. The technology related to power generation with wind turbine is presented in Figure 14.

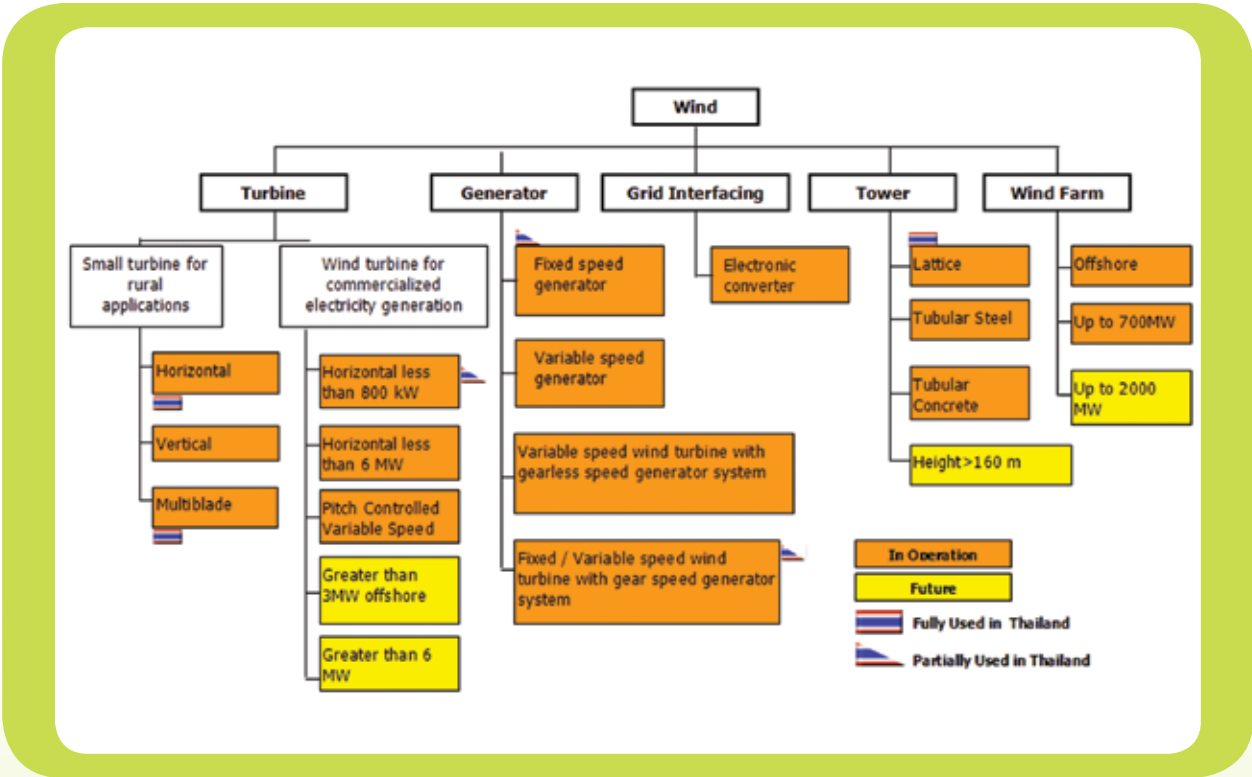

Figure 14 Wind Technology Illustration [16]

## Research and Development on Wind Energy Technology

Most research and development in Thailand focus on identifying wind energy potential with mathematical models or through the use of measuring equipment. The research on wind energy technologies that should be considered by researchers in Thailand covers the following issues;



## Design and Power Control System for Wind Turbines

During the past decade, several international research institutions have developed airfoil section specifically for wind turbine and have it registered for intellectual property rights. The next stage of development is to develop a stronger airfoil section capable of fiercer separation flow. As for the future development of power control technology for wind turbine, there are 2 ways to control the mechanical energy from aerodynamics, namely decreasing the impact angle to reduce the force, and increasing the impact angle to induce stall phenomenon. However, new technologies mostly focus on increasing the reaction speed of the system and the control of impact angle of the turbine blades. Moreover, modern wind turbines have an equipment for monitoring wind speed installed in the hub area or above the engine room. The disadvantage of this system is that there is a delay in adjusting the angle of the blades as the system can only gather the wind speed after the wind has already hit the blades. The use of laser based anemometer (LIDAR) or laser to measure the wind speed that is moving towards wind turbines allow the system to collect the information and adjust the angle of the blades accordingly in time for wind impact. Besides, the fact that the system is informed of the wind speed prior to the impact will allow future blades to be longer and will reduce the damages caused by a sudden increase in wind speed. The vibration of the tips of turbine blades during operation has an impact on the angle of the blades. The vibration sensor technology for the tips of turbine blades can help send information to the control system to readjust the angle of the blades to balance the aerodynamics.

The design of wind turbine in Thailand mostly use the standard airfoil section, such as that of NACA or NASA. The airfoil section developed by international research institutions are registered for intellectual property rights. Therefore, a new airfoil section should be self developed for domestic uses, As for the power control system for wind turbines, Thailand is only in the early stage, due mainly to limited experiences only with small wind turbines which does not require power control system. The larger wind turbines (50 kW) are only in an experimental stage. Therefore, the research and development of power control system for wind turbines should commence immediately.

## Technology for Producing Wind Turbine

Even though many manufacturers still use the layering process in an open mold, the more stringent environmental controls have made manufacturers change their production methods to involve less use of volatile substances. There are 2 new production processes currently used, namely prepreg and infusion systems. Nevertheless, both of these processes require expertise in designing and in production technology, especially the part which uses composite materials in thick layers. This is because the infusion system requires extra care



and expertise in the flow of resin based material throughout the layers of dry fibers. The prepreg system requires elimination of excess resin during the production process to prevent excessive resin in any given area and gas pockets trapped inside the composite blades.

A new method that deserves attention is the use of resin-coated fibers as prepreg, with partial dry fibers. During the process of fiber layering, the dry fibers will allow air to flow out easily, while all layers will be in vacuum. Afterwards, pressure and heat are given to all layers of fibers to allow resin to be absorbed by the dry fibers, with all layers of composite to be combined perfectly.

The preparation of composite materials with high temperature production is necessary for prepreg and infusion processes. In general, prepreg fiber needs a preparatory temperature of around 90-110°C, where as the resin epoxy in infusion process requires 60-65°C. Once the layer of composite is thicker, there is an increasing difficulty in controlling temperature and heat during production to be stable. In general, the costs of mold and equipment depend on the heat requirement in the production process of a given technology. An automatic system for layering in a mold is an alternative production process with good potential, as manufacturers can control the layering of fibers with precision and can reduce the manpower and time during the production.

Composite material industries in Thailand that are closest to a wind turbine blades is the water sports equipment industry that produces for domestic and international markets. Therefore, it is the industry that researchers can potentially conduct a joint research for the construction of wind turbine blades.

## Gearbox Technology

There is now an industrial standard of the gearbox for wind turbine. Future technological development will have no gearbox for wind turbine. This is called gearless system, requiring technological development in generators and controllers instead. If Thailand wants to undertake research and development in order to produce gearbox for wind turbine, manufacturers will have to have readiness in several aspects, especially experience in manufacturing gearbox for other heavy industries, such as gearbox for large ships and mines. This is the experience which Thailand lacks.





## Hydro Power and Related Technology

Hydro turbines can be categorized by the water head levels, namely high, medium, and low levels. These levels have a direct correlation with the size of turbines. Low water head requires a large turbine, whereas high water head requires a small one when compared at the same production capacity. The main reason for differentiating the design of hydro turbines operating at different head levels is the rotation speed of the power generator. The turbines have to be designed accordingly to have a corresponding rotational speed to that of the generator. Small hydropower can be divided into 3 sizes according to their production capacities, namely small hydropower with 1-30 MW capacity, mini hydropower with 200 kW - 1 MW capacity, and micro hydropower with capacity less than 200 kW.

Moreover, hydro turbines can be divided into 2 types according to the nature of their operation, namely impulse turbine and reaction turbine.

1. Impulse turbine, or pelton turbine, changes the kinetic energy of hydropower into potential energy when the turbine rotates. Pelton or Turgo turbines have single or multiple nozzles to help increase water speed. This type of turbine operates under air pressure while





the blades was not totally submerged after water hit the blades and down to the exit underneath. There are 3 main kinds of impulse turbines.

- **Pelton Turbine** consists of wheels with buckets at the rim. Water flows through nozzle and causing the wheel to rotate with high-speed water making water flow down underneath the wheel.

- **Turgo turbine** operates similarly to the Pelton turbine. However, the water that flows through nozzle is designed to impact with the wheel with a specific impact angle (around  $20^\circ$ ). Water flows in from one side of the turbine and flows out in the other side.

- **Cross flow (or Banki) turbine** consists of runners similar to a squirrel cage turbines. Water comes through a nozzle above the turbines and impact with the upper part of the turbine and subsequently the lower part before flowing out below.

2. Reaction turbine comes in both horizontal and vertical axis. In theory, reaction turbine relies on the difference of pressure on the runners for rotation. At the rear of the turbine, there is a diffuser tube called draft tube designed for water flow in order to increase the static pressure in the exit area of the turbine where pressure is low. This type of turbine is more complicated to be designed than the impulse ones, in terms of both the shape and the draft tube. Nevertheless, this kind of turbine is suitable for low head water and is very popular in research and development. Reaction turbines can be divided into 2 main types.

- **Propeller-type turbine** operates similarly to ship propellers only in the other way round. Fixed guide vane is the key equipment which control the flow direction, installed in front of the turbines. The adjustable turbine runners are called Kaplan. The mechanism for angle adjusting and the angle of the guide vane have high cost, only suitable for large turbines. However, angle adjustment of turbines can help increase efficiency of water flow in general. Francis turbine is a turbine applied from the propeller turbine by controlling water flow within its range towards the turbine, and flow out along the turbine's axis. The runner is located in the middle of a snail-shaped casing with a guide vane that helps adjust impact angle.

- **Kinetic energy turbine**, or free flow turbine, can produce electricity from kinetic energy, such as flowing water. This is different from using potential energy that exists due to the difference in head levels. It is suitable to be used in rivers, canals, tides or ocean currents. Kinetic energy system can be used with the water flow channels without the need to use tubes to control the flow. It does not need large structure and can be used with bridge-type structures.



Power generator of a hydro power plant is similar to that of other type of power plants. The most popular types of generator are (1) synchronous generator, (2) induction generator, and (3) permanent magnet generator.

Synchronous generator is suitable for stand-alone power plants which requires an automatic control of water quantity used for power generation per demand through a control equipment called governor. As for induction generator, it is suitable for grid-connected power plants. The generator operates alongside programmable logic controller which controls the operation of the hydro turbine. Permanent magnet generator is also suitable for grid-connected power plants. This kind of generator gains an increasing popularity. It is suitable for low-head hydro turbine as it is able to generate electricity at various rotational speeds. It also requires an inverter to adjust the electricity frequency to be at 50 Hz. Other equipment necessary for a generator include controller box, transformer, and switchyard. The technologies related to electricity generation with hydropower are presented in Figure 15.

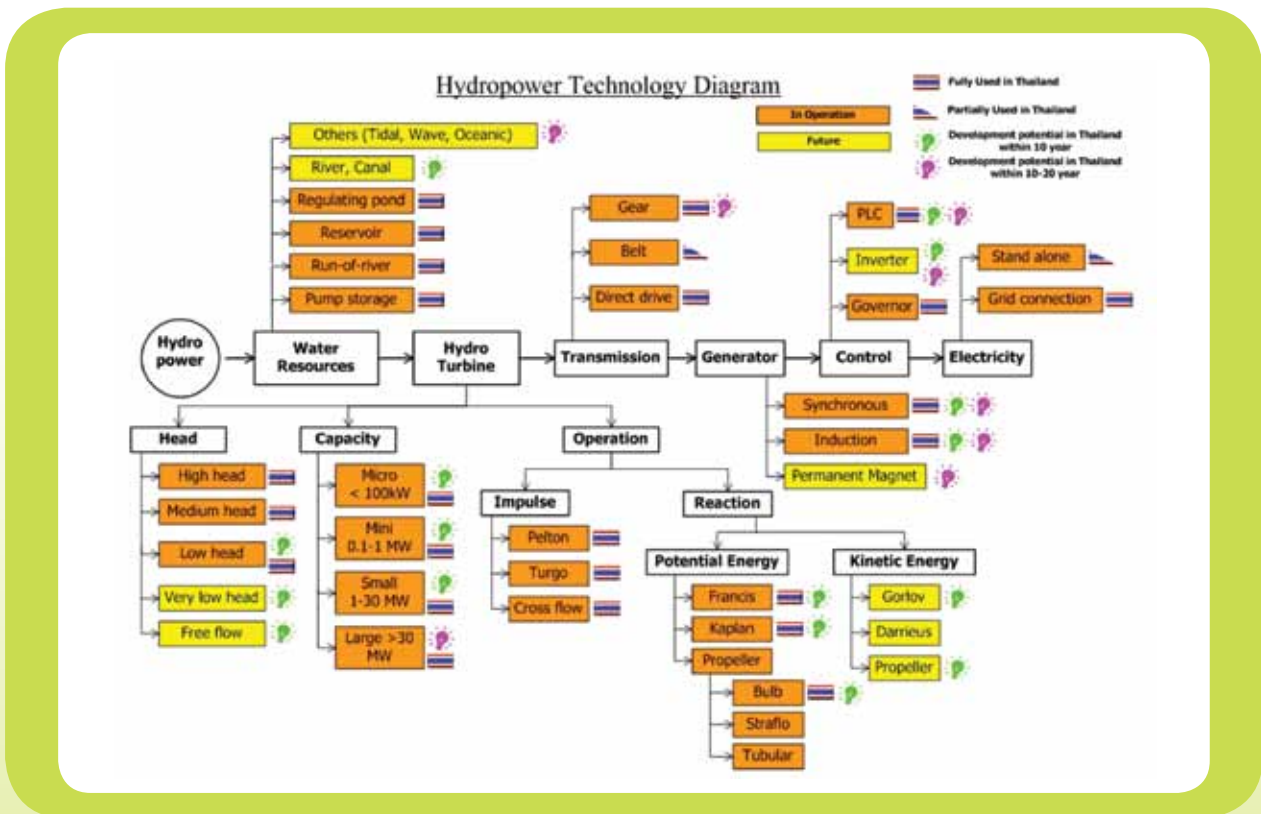

Figure 15 Technologies Related to Hydro Power Generation [15]



## Research and Development on Hydro Power

In Thailand, it is agreed that the responsibility for developing hydropower sources for small and very small power generation be divided among 3 agencies, namely the Electricity Generating Authority of Thailand (EGAT), the Provincial Electricity Authority (PEA), and the Department of Alternative Energy Development and Efficiency (DEDE). It is agreed that for a project which is financially feasible, EGAT or a private company will undertake the project development. DEDE will undertake projects which are socially feasible, but not economically with the capacity no more than 6 MWe. When the project sites are to be located outside national parks and wildlife sanctuaries. At present, all 3 agencies have prepared action plans for small and very small hydro power projects. EGAT has 3 projects, with combined capacity of 28 MW. PEA has 4 projects, with combined capacity of 27 MW. In addition, DEDE has 98 projects, with combined capacity of 350 MWe.

DEDE has developed 75 hydropower projects in villages, with combined capacity of 2,500 kWe. DEDE invests in construction and allow local community to have ownership in a form of cooperatives. DEDE is responsible for project designs, sources of fund, materials, necessary technology. Local community provides manpower, and locally available materials, such as stones and sand. It is expected that 50 hydro power plants will be constructed at the existing dams and additional 400 plants at the existing dikes with a combined capacity of over 190 MW. Moreover, if there is an efficiency upgrade for the existing hydro power plants by changing electromechanical equipment in the next 10 year, it is expected that a capacity of 86 MWe could be added.

Thailand currently has experience exploring for hydropower sources, structural designs, and construction of small and large dams with capacity over 100 MWe. However, there is a low capacity in designing, constructing and manufacturing hydropower turbine and electromechanical systems. DEDE can produce radial flow hydro turbine of a size smaller than 6 MWe through a number of private contractors. However, it cannot design or produce axial flow hydro turbine. Recently, EGAT has cooperated with energy and environmental academic institutions to design and manufacture small hydro turbines to be installed at dams. These turbines can only operate at water pressure of 2.5-3 meters, with the installed capacity of around 28 kWe and efficiency of 75%. The majority of the equipment, such as runner, power generator, and electromechanical equipment, are developed domestically by research team and the Department of Naval Dockyard.



# Waste and Related Technology

The technologies for energy from waste can be divided into 8 groups as follows;

**1) Incineration technology** is very flexible in terms of waste inputs, allowing it to reduce mass and volume considerably. It also takes little time to produce a large amount of energy. It is the system that requires the least space. It can operate with Refused Derived Fuel (RDF), but requires costly investment. The minimal size for feasible investment and for break-even energy production is 250 tons/day. It is a sophisticated technology. Thailand has not yet to be able to produce this technology. It also has a public perception problem, resulting in a requirement of efficient pollution treatment system and a team of special experts.



**2) Gasification technology** is a clean technology which can significantly reduce mass and volume. It only requires a short period of time. A large quantity of energy can be produced in a relatively small area. A small system (less than 1 MW) can be developed domestically. It can operate with RDF, but require a preliminary waste management, such as prepping waste in the form of RDF. However, this will require a costly investment and high operation and management. There is also a lack of commercial reference. A large system which is a sophisticated technology cannot be constructed in Thailand yet as the technology is not available domestically and highly costly.

**3) Pyrolysis technology** is a clean technology, able to reduce mass and volume significantly. It requires a short period of time to produce a large quantity of energy in a relatively small space. Small system (less than 1 MW) can be developed domestically. It can operate with RDF, but require a costly investment and high operation and management. There is also a lack of commercial reference. A large system which is a sophisticated technology cannot be constructed in Thailand yet as the technology is not available domestically and highly costly.

**4) Plasma Arc Technology** is capable of handling a variety of garbage or waste even though each waste has different melting point. There is a small volume of gas exhaustion from the system, requiring only low investment in air pollution treatment system and reducing emission of dioxin. This technology also provides a complete thermal biodegradation in the secondary chamber. However, this technology is not commonly used with community waste. It is still in the research and development stage. There are not many large systems. It is also

a sophisticated technology that cannot be constructed in Thailand as yet.

**5) RDF technology** is a clean technology that can be used together with gasification. The fact that the plants are small in size allows it to be built across the places where wastes are generated. Moreover, the raw materials do not need to be used to produce power immediately. Materials can be stored for later production. It also requires only small space. More importantly, it is a technology which can be developed domestically. However, it is not a stand-alone unit and the residue waste need to be discarded. There is also a lack of commercial reference. The market for energy from waste is still absent. There is a need to establish such market in Thailand.

**6) Anaerobic digestion technology** is a clean technology. The waste composition in Thailand has a high proportion of biodegradable contents. The technology is not complicated and can be developed domestically (except for the generator system). However, a good waste management system is required, with separation of organic wastes from other type of wastes. Only with good management can the technology operate at full efficiency. There is also a need to develop a strain of microorganism that can generate high level of biogas and can withstand the environment. A market for soil improvement materials has to be created to generate additional income for the system.

**7) Landfill-Gas-To-Energy technology** is a clean technology. The waste composition in Thailand has a high proportion of biodegradable contents. The technology is not complicated and can be developed domestically (except for the generator system). However, there is an issue with the quality of the output gas and the pollution that may happen from improper control.

**8) Bioreactor-Gas-To-Energy technology** is a clean technology. The waste composition in Thailand has a high proportion of biodegradable contents. There is also a lack of commercial reference. Moreover, it is a large system that requires costly investment. Thailand is still unable to develop this technology domestically.

The technologies related to energy from wastes are presented in Figure 16.

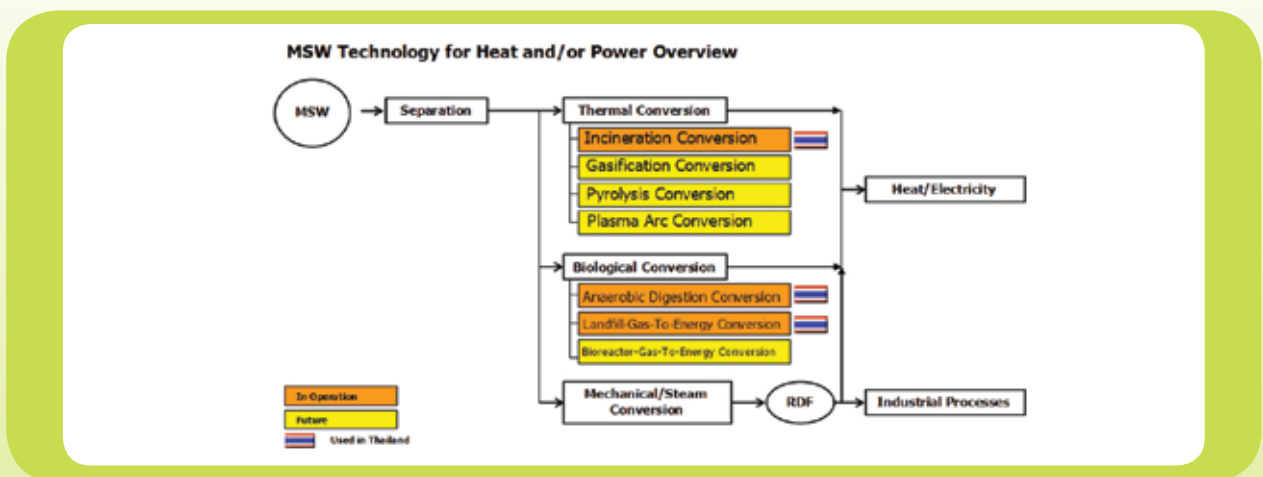

Figure 16 Technologies Related to Energy from Waste

## Research and Development on Energy from Waste Technologies

Research and development on energy from waste technologies can be divided into 3 groups as follows;

### Group 1: Anaerobic digestion technology, landfill-gas-to-energy technology, and refused derived fuel (RDF)

This group of technology is ready and suitable for the types of waste in Thailand. They can be used with small (less than 100 tons/day) to medium (100-250 tons/day) sources of waste. These technologies require a waste management system. Even though the energy produced per unit is not extensive, but the technologies can be dispersed to a range of locations. Limitations of the technologies include waste separation for anaerobic digestion, which will be suitable for fresh markets and canteens. On the other hand, RDF needs to be located near to sources of waste and needs a waste separation system.

Anaerobic digestion technology is ready and can be immediately deployed. However, the technology relies heavily on import contents. The energy produced is in a limited level. There is also a need for waste separation to select only organic wastes which are compatible with the system. The technology can handle small and medium sources of wastes. There are currently many landfills which can produce energy if needed. As for the landfill-gas-to-energy technology, it will require gas extraction system to allow the technology to produce energy at full capacity. Moreover, there is a limitation on forecasting quantity of gas, gas purification. This technology can be used with medium to large source of wastes. On the other hand, RDF can only be used with a small source of wastes as materials for power production, such as gasification. Nevertheless, there is no example in Thailand and there is no market to sell the power to.

### Group 2: Incineration, gasification technology, and pyrolysis technology

The technologies of this group are mainly thermal technologies. They are popular in other countries as they can handle large quantity of wastes without the need for waste separation. The level of energy produced per unit is higher than other technology. This group of technologies requires a costly investment, but can be used in large to extra large source of wastes. Incineration has high costs of investment and operation. It also causes environmental problems. It does not require waste separation and can produce more energy than other technology. Gasification technology is popular in other countries. It is still in experimental stage with a number of prototype factories. It is a clean technology, but has limitation with regard to investment. Pyrolysis technology is still in experimental and prototype stage. It is a clean technology, but has limitation with regard to investment.



### Group 3: Plasma arc technology and bioreactor-gas-to-energy

The technologies of this group not yet ready for deployment as they are in research and development without any application in Thailand and other countries. Plasma Arc technology is in research and development stage. Bioreactor-Gas-To-Energy is in technological development stage. It can be used with old landfill sites that have a problem on waste erosion by water.



## Biomass and Related Technologies

Biomass is from organic substance of crops and animals through a process which transforms biomass into various kinds of energy. The technologies can be divided into 3 groups as follows;

- **Thermochemical process** transforms biomass into energy by using heat to induce chemical transformation, such as combustion, pyrolysis, and gasification.
- **Biochemical process** transform biomass into energy by using biochemical reaction which requires microorganisms, such as bacteria and fungus in fermentation until biomass is transformed into energy such as ethanol and methane gas (CH<sub>4</sub>).
- **Chemical process** transforms biomass into energy through chemical reaction such as biodiesel.



As for Thailand, the biomass being brought for heat and electricity generation can be divided into 3 groups; namely agricultural waste and agro industries, residues from processed wood industries, furniture and biomass from fast growing crops. Nevertheless, an evaluation of potential for heat and electricity production from biomass mentioned above found that the agricultural waste and agro industries have the highest potential.

Thailand's essential agricultural crops include rice, sugar cane, palm, and cassava. Each year, there is a large amount of agricultural waste and agro-industries. An evaluation found that the biomass from agricultural wastes, such as rice husk and bagasse, are already used to produce energy to nearly full capacity as in the case of rubber wood chips that left over in wood-processing and furniture factories. But few of them remains in the farms, such as small branch and tree roots, which are difficult to be collected and are expensive to be transported. However, there are high capacity that remains for energy production from rice straws, sugar cane leaves, corn plants and palm bunch.

There are several technologies for transforming biomass-chemical energy to heat and electricity. Most technologies involve a range of processes such as biomass preparation process, production process, and electricity generation process as depicted in Figure 17.

Biomass preparation process prior to energy production usually includes chipping, grinding, pulverizing, briquetting, or pelletizing, moisture reduction with drying or dehydrating.

In Thailand, there is still no commercial production of briquetted biomass as the cost is high. In other countries, briquetted biomass, especially wood chips, is produced to reduce transport costs. Meanwhile, briquetted biomass is also used for boilers in industries to increase efficiency and for household uses.

The main technologies related to the transformation of biomass into heat and electricity through thermochemical process include combustion boiler and steam turbine, gasification, pyrolysis, pollution emission and control technologies as a result of biomass energy production.





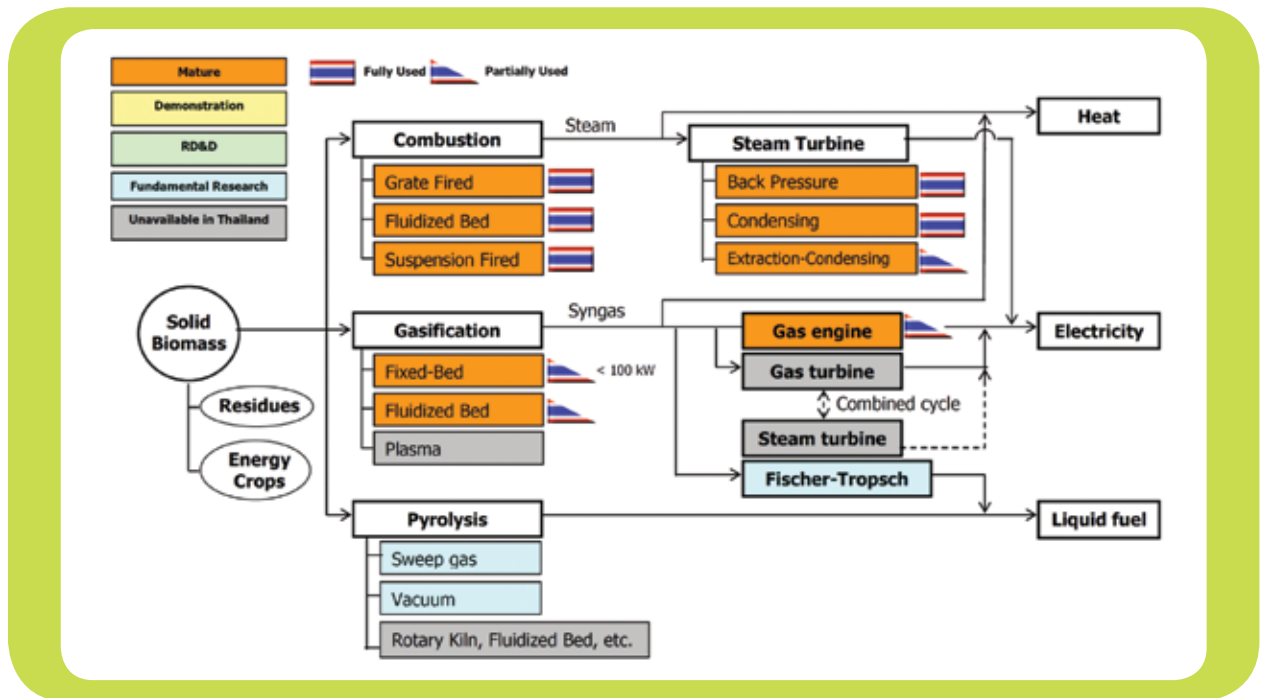

Figure 17 Status of Heat and Electricity Production Technologies from Biomass [15]

## Research and Development on Biomass

There are current researches related to a number of technologies that transform chemical energy in biomass into heat and electricity. The research involves many processes such as biomass preparation prior to energy production, biomass production process and electricity or heat generation process. From a review of research done during 1996-2012, there were 173 pieces of biomass research conducted by 4 main institutions namely, King Mongkut's University of Technology Thonburi, Naresuan University, Kasetsart University, Chulalongkorn University. The related research and development can be divided into 4 groups as follows.

- **Group 1** : research on the potential of materials focuses on assessing the overall potential of biomass as raw materials for electricity and heat production in a given area in Thailand. The research also involves the analysis of new materials that can potentially be used to produce electricity and heat.

- **Group 2** : research on biomass preparation process focuses on finding a way to improve the quality of biomasses to be more suitable for power and heat production, such as chipping, grinding, pulverizing, briquetting, pelletizing, and humidity reduction.



- **Group 3** : research on electricity and heat production technologies from biomass focuses on improving production process and quality of technologies in producing power and heat from biomass.

- **Group 4** : research on economics and environmental impacts of biomass focuses on the cost and environmental impact, especially from the pollution created from biomass production. This includes ways to reduce costs and impacts from using biomass to produce power and heat.

Most of the research in Thailand falls under Group 3 which focuses on improving the process of producing power and heat from biomass, including developing and improving efficiency of technologies for producing energy from biomass, such as gasification. There are also a number of researches that fall under Group 1 and 2 namely, researches that focus on identifying potential of biomass as raw materials for electricity and heat production and analysing for new materials, as well as finding a way to improve the quality of biomass to be more efficient for power and heat production. The research on the cost and environmental impact from biomass production is comparatively limited. This group of research focuses on cost analysis of energy production and ways to reduce such costs.

**Research on biomass technology that should be promoted can be divided into 4 groups as follows.**

1. Research on biomass resources, with a focus on collecting and transporting biomass materials that still have potential for power production and on developing knowledge on fast-growing crops to be used in energy production.

2. Research and development on fuel preparation, with a focus on properties of each biomass fuel, as well as making a database on biomass fuel in Thailand and biomass briquetting process.

3. Research and development on technologies related to transformation of biomass into energy, with a focus on increasing efficiency of energy production process in the potential factory group, as well as a study on preventing and resolving issues related to declining efficiency for both present and future systems. A knowledge body on a mixed combustion between biomass and coal, and the environmental impact of the technology should be created.

4. Capacity development of personnel and domestic equipment for upcoming technologies with potential for commercial deployment in the near future, as well as a development of prototype factory in Thailand which will also help increase capacity in producing technology for export.





## Biogas and Related Technologies

Biogas is one of the alternative energy sources among renewable energies in Thailand that has high potential and lower cost than other renewable energies. The biogas sources can be locally found in the forms of waste from agro-industry's production process, such as waste from animal farms, wastewater from agro-industrial factories, which have currently been utilized for biogas production. Moreover, agricultural solid wastes and energy crops are considered as the significant source of raw materials for biogas production. There are many opportunities in producing energy from biogas from these waste materials that are suitable for degradation, such as those with high carbohydrate content or high humidity.

Overall status of biogas technologies that are available in Thailand and other countries are presented in Figure 2.13. It is discovered that biogas technologies available in Thailand have already been commercially deployed in other countries. The current use of biogas technologies at industrial level in Thailand involves both imported technologies from other countries (with system designed by foreign experts) and technologies that are developed and improved domestically (construction and installation overseen by local entrepreneurs). Tank reactor technology, which is not yet used in Thailand, is mostly in research and prototype stage, such as EGSB and IC AMR tank reactors.



As for wastewater from agro-industry, the commonly used technology in Thailand is mostly dug lagoon, such as covered or modified lagoon technology, as it takes a short time to build and is believed to be cheaper than building a tank reactor. The second most commonly used technology is UASB which is mostly used in factories with limited space and personnel readiness for the technology system maintenance. Apart from sanitary landfill technology, biogas production from organic waste in other countries also uses tank reactors, using both wet process with CSTR tank reactor and dry process. Biogas production from organic waste in Thailand uses sanitary landfill system. However, single stage CSTR is imported for demonstration project which is not yet commonly used.

In the case of biogas production from solid organic wastes, such as yard waste and energy crops, other countries mostly use CSTR tank reactors with an additional pre-treatment process, such as mechanical process, thermal process, acid/alkaline process, or enzyme and biological treatment. The mixed enzyme method in Thailand is still at a research and development stage. There are some engineering developments in a demonstration stage by private sector (i.e. building a operational system with engineering improvement to the design of tank reactor). For instance, the principle of modified covered lagoon is improved by managing the sediments and stirring for agricultural materials, with an additional mechanical pre-treatment process or thermal and acid treatments.

As for the technology for biogas production system, the covered lagoon and modified covered lagoon are the technologies which are most commonly used in Thailand as they can be built quickly. Thailand also has no limitation in term of space. Similarly, in the U.S., modified covered lagoon is also commonly used in processing waste from livestocks. On the other hand, the CSTR is more commonly used in European Union, as it requires less space. As for biogas production technology from industrial wastewater, apart from modified covered lagoon, UASB and AFF technologies are also used in Thailand.



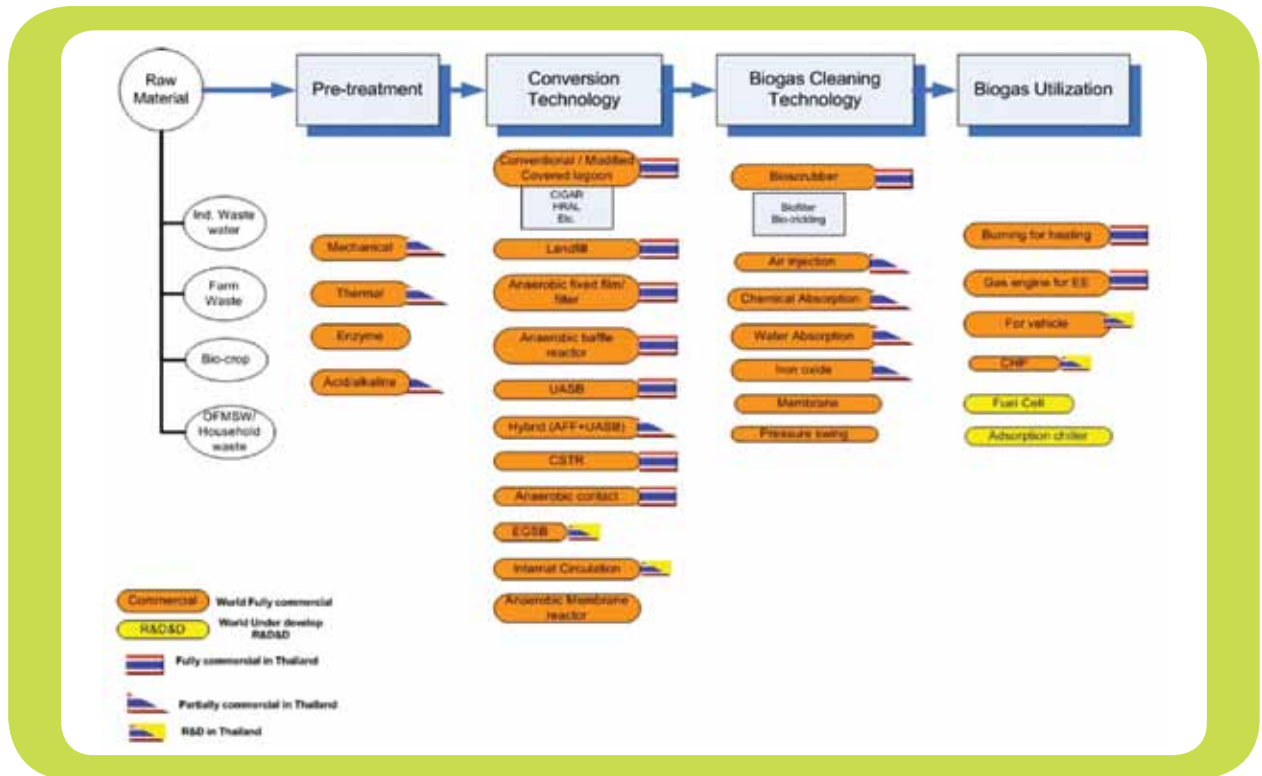

Figure 18 Status of Heat and Electricity Producing Technologies from Biogas

## Research and Development on Biogas Technologies

Current research on biogas technologies is related to various processes including pre-treatment of raw materials, biogas production from a variety of materials, the applications of biogas, such as heat and power generation, and automobile fuel. From a review of research during 1996-2012, it is found that there are 134 pieces of research related to biogas. There are 4 main institutions that are involved in biogas research, namely Chiang Mai University (as there is a dedicated agency for biogas research within the institution), Kasetsart University, KingMongkut's University of Technology Thonburi. The research and development of biogas technologies can be divided into 5 groups as follows.

- Group 1 :** research on potentials of raw materials focuses on the overall potential of materials which can be used to produce biogas such as wastes from farms, wastewater from agro-industries and food factories, wastes from agricultural zones, including the wastes from agro-industries and energy crops (weeds and fast-growing crops) in areas within Thailand. The research also covers an analysis on new materials that can be used for biogas production.



- **Group 2** : research on material preparation process before being transformed into biogas involves study on pre-treatment of new materials so that they are more suitable for biogas production.

- **Group 3** : research on biogas production technologies focuses on developing production process and improving efficiency of biogas production from a variety of materials.

- **Group 4** : research on ways to improve biogas quality focuses on improving biogas for a variety of application, such as heat and power production, and automobile fuel.

- **Group 5** : research on economics and environmental impact of biogas focuses on the costs and environmental impacts, especially from the pollution created from biogas production. This includes ways to reduce cost and impact from using biogas for power and heat generation.

Most of the research in Thailand falls under Group 3 as most researches involve finding new ways to improve biogas production process and improving efficiency of power producing technology from biogas. There are a number of researches which fall under Group 1 as they focus on identifying potentials of biogas materials and finding new materials for biogas. On the other hand, researches that fall under Group 2, 4 and 5 are comparatively limited in number.

To promote commercial development of biogas, support should be given to the development of prototypes and projects at demonstration level. Setting standards for biogas technology should also be supported, in terms of both construction and maintenance. Moreover, there should be trainings for entrepreneurs or personnel related to biogas technology on regular basis in order to create capacity and support for production of biogas equipment and machines. There should be a national testing agency that can provide standard certificates for biogas technologies. Moreover, incentives for using or researching new biogas technologies for entrepreneurs will contribute to further research and development.





## Ethanol and Related Technologies

Ethanol is an alternative fuel for benzene in transport sector. Production of ethanol depends on the type of materials used for production. Ethanol materials can be divided into 3 groups. Firstly, sugar group includes molasses and bagasse which can be directly fermented with yeast without any pretreatment. Secondly, the flour group includes cassava, corn, and rice. The production process for this group needs to be saccharified into sugar before they can go through fermentation process with yeast to change sugar into ethanol. Lastly, cellulose group includes rice husk, bagasse, and corncobs. This group will involve 3-stage process, namely pretreatment to breakdown the cellulose molecule before they are saccharified (with acid or enzyme), and then fermented into ethanol at the final stage. At present, the materials in Thailand with the highest potentials for producing ethanol are cassava and sugar cane (or bagasse).

Ethanol is created from the transformation of sugar (glucose and sucrose) through Embden-Meyerhof-Parnas pathway, or glycolysis pathway of yeast-type microorganisms. Therefore, molasses and bagasse are materials easy to be fermented into ethanol, while materials with flour as their main components, such as cassava, will need to be saccharified into glucose and then fermented into ethanol. Moreover, the 2<sup>nd</sup> generation



ethanol can also be produced from sucrose type materials as well. Ethanol production technology from biomass is depends on the type of materials used to produce ethanol. The difference in ethanol production process for each type of materials is as follows.

1. **Sugar group materials include molasses and bagasse which can be directly fermented with yeast without any pretreatment.**

2. **Flour group materials include cassava, corn, and rice. In the ethanol production process, flour is saccharified into glucose which is a single molecule sugar so that yeast can then change sugar into ethanol. This process involves 2 steps.**

- **Liquefaction** : this process uses acid or alpha-amylase enzyme to saccharify flour into smaller molecule with less thickness. The output liquid of this process is called maltodextrin and it has dextrose equivalent between 10-15%.

- **Saccharification** : this process involves glucoamylase enzyme which continues the process till the output is single molecule sugar before it goes through fermentation process with yeast to change sugar into ethanol.

3) **Cellulose group materials include rice husk, bagasse, and corncobs. The lignocelluloses materials consist of 3 main components, namely cellulose, hemicelluloses, and lignin, along with other compounds. Cellulose is a polymer of sugar in a form of linear chain of linked glucose units. It is in a crystal structure, forming water-insoluble thick fiber. Hemicellulose is a polymer of several types of pentose such as xylose, mannose, and arabinose. Lignin is a polymer of phenylpropane, which is very hard to breakdown. Ethanol production from lingocellulose involves 3 stages as follows.**

- **Pretreatment** breakdowns the bonds between cellulose and other compounds so that cellulose enzyme can access and digest cellulose more easily. There are several methods of pretreatment, such as a chemical method which includes dilute acid, concentrated acid, breakdown with ozone or base, or physical methods which includes steam explosion. Alternatively, both methods can be used, depending on the type of the materials.

- **Enzyme hydrolysis** breakdowns either the molecule with acid or enzyme. Breaking down with acid involves 2 stages. The first stage is breaking down hemicelluloses into pentose. The second stage is breaking down cellulose into glucose with enzyme. The current





technology is simultaneous saccharification and fermentation (SSF) which are combined breakdown and fermentation process in a single tank.

- **Sugar fermentation with yeast-type microorganism**

At present, industrial production of ethanol uses flour and sugar materials. Cellulose materials have high potentials and attract interest internationally. There are research and development as well as prototype factories. Figure 19 illustrates a variety of technologies used in each ethanol production process from biomass. The current technologies employed in Thailand and in other countries and the technologies under development with expectation for actual deployment are both presented.

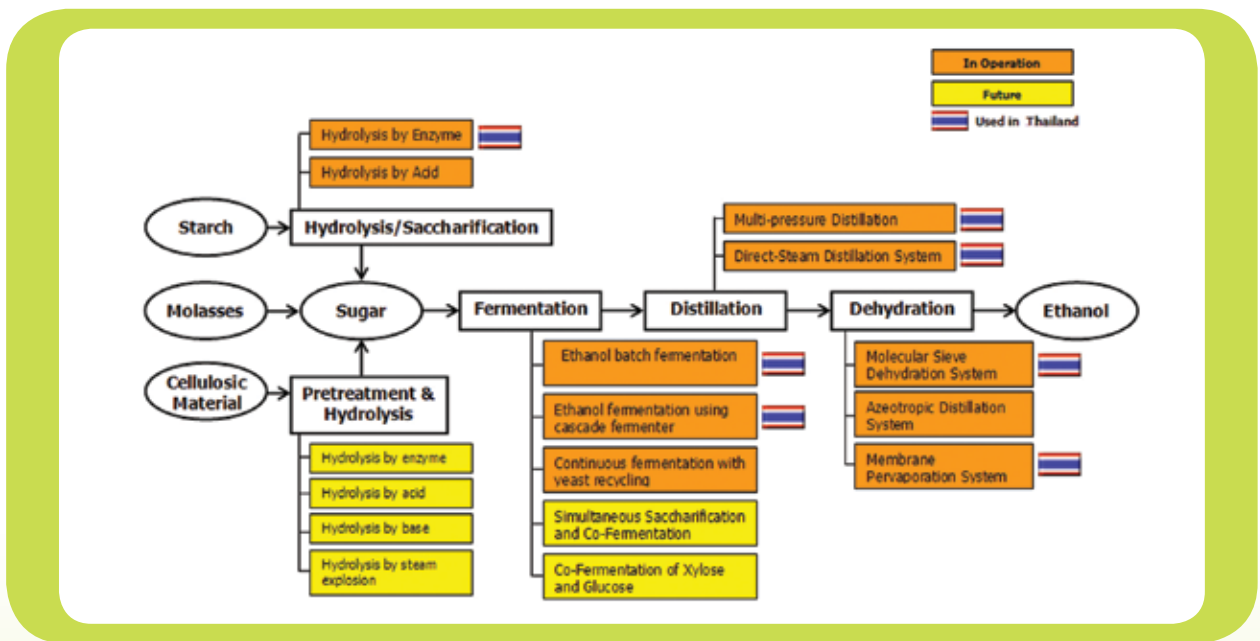

Figure 19 Status of Ethanol Production Technologies [15]

## Research and Development on Ethanol

Current research on ethanol technologies covers a variety of processes, including efficiency improvement of material farming, ethanol production process, and the impact of using ethanol in automobile, including the ways to support ethanol use. From a review of related research on biomass energy during 1996-2012, there are 305 pieces of research related to ethanol. It is found that there are 3 main institutions that conduct research



on ethanol, namely Chulalongkorn University, KhonKaen University (which is located close to areas that grow energy crops for ethanol production, including sugar cane and cassava), and Chiang Mai University. The research and development can be divided into 4 categories.

- **Group 1** : research on potentials of raw materials focus as on the overall potentials of materials which can be used to produce ethanol including analysis of an area's potential in growing crops, study on logistic management for material collection for ethanol production, and efficiency improvement of raw materials, such as yield improvement. Moreover, there is a search for new materials with potential for 2<sup>nd</sup> generation ethanol, such as lignocellulosic ethanol.

- **Group 2** : research on ethanol production technology focuses on improving production process and increasing efficiency in ethanol production from various materials.

- **Group 3** : research on the use of ethanol in automobiles focuses on the impact on automobile engines from using a mixture of ethanol with benzene in different ratios, as well as a support for using ethanol instead of diesel in diesel engines.

- **Group 4** : research on economics and environmental impact of ethanol production focuses on the cost and environmental impact, especially from the pollution created from ethanol production from various materials and technologies. This includes ways to reduce cost and impact from ethanol production.

Most researches in Thailand fall under Group 1 and 2 as studies focus on identifying potential of raw materials in producing ethanol, and on efficiency improvement for ethanol production process from various materials, especially non-food materials. Meanwhile, researches that fall under Group 3 and 4 have a comparatively low proportion, especially the research on production cost and environmental impact throughout the production life cycle of ethanol from various materials.

## Concentrations of Research and Development on Ethanol Production can be divided into 5 aspects

**Firstly, development in plant genetics and cultural control for biofuel production involves the following research samples;**

- 1) Development and modification in plant genetics, such as fast-growing cassava and sugar cane which give higher yields in terms of flour and sugar. Selection and modification of genetics use both traditional and applied biomolecular technology, such as marker-assisted selection, to get most suitable ones for Thailand.



- 2) Development in crop cultural control management and transfer of knowledge on plantation, cultivation, maintenance to farmers in order to reach GAP standards,
- 3) Area management with precision farming, including the use of GIS technology in planning for farming,
- 4) Setting production and promotional plans for sugar cane and cassava plantations at a balanced level to maintain price stability of the materials as well as increase yield per area to prevent problems with cultivation areas.

**Secondly, logistics development for material collection and transportation involve the following research topics;**

- 1) Selection of energy crops suitable for biofuel production by using information on material potential such as yield per area, growth rate, cultivation cost, utilization probability,
- 2) Study for suitable collection method by considering the quality of delivered materials and the locations of plantation along with the locations of biofuel factories, as well as the cost of transportation per unit.

**Thirdly, development of production process and prototype factories in order to use materials efficiently and to reduce costs involves the following research topics;**

- 1) Development of simultaneous saccharification and fermentation processes for cassava materials to reduce energy consumption and contamination during the saccharification process, as well as enzyme development for breaking down raw flour to reduce energy consumption in production process,
- 2) Development of process and system of ethanol production that can use a variety of materials or cheaper materials, such as fresh cassava roots instead of flour or processed cassava so that materials can be chosen on cost-efficient and seasonal basis,
- 3) Selection and improvement of yeast genetics with biomolecular technology so that yeast can withstand high temperature and highly concentrated ethanol,
- 4) Development of control system for saccharification and fermentation,
- 5) Development of fermentation process that can produce highly concentrated ethanol. This can help reduce cost of ethanol purification, including the method that uses large quantity of raw material in the fermentation tank, such as high solid loading fermentation for cassava materials,
- 6) Development of ethanol factory's wastewater utilization for producing biogas to energy, or for producing fertilizer for plantation,



7) Development of utilizing the solid residue from fermentation, including other by-products from ethanol production process in order to create overall value added,

8) Supporting sugar mills to invest in ethanol production by building ethanol factory in the same area to reduce investment risks,

9) Development of prototype factories that combine cassava flour and ethanol production together, or for ethanol production from other materials to create engineering know-how.

**Fourthly, research and development on ethanol production from cellulose with efficient, sophisticated technology involves the following research topics;**

1) Development of pretreatment of cellulose with steam or pressured water that may work with other solvents or carbonic acid,

2) Development of yeast genetics that can transform pentose into ethanol,

3) Using biomolecular technology to develop cellulose enzyme that can change cellulose into sugar efficiently and cheaply,

4) Using small prototype factories to gather engineering know-how for future expansion.

**Fifthly, research on policies, especially on cost and ways to reduce ethanol production costs, including promotional measures for greater use of ethanol involves the following research topics;**

1) Research for suitable cost structures for both raw materials and biofuel,

2) Research for suitable management of demand and supply of each raw material and biofuel,

3) Development of management so that the entire biofuel industry is sustainable with no impact on food security and land use,

4) Preparation for relieving measures for old automobile models that can be affected by the announcement of E10/95 to be used across country, such as assistance for consumers in changing equipment or parts without or with little charge.



# Biodiesel and Related Technologies

Biodiesel is a mono alkyl ester compound which is a result of transesterification reaction between vegetable or animal oil (which is a triglyceride organic compound) and alcohol with acid or base as catalyst. The output of this reaction is ester, as well as glycerol. There are 2 main reactions that create methyl ester, namely transesterification and esterification reactions.



**1) Transesterification** is the most commonly used process in methyl ester production. Triglyceride is transformed into ester through reaction with excessive amount of alcohol, with alkaline solution as catalyst, such as sodium hydroxide, and potassium hydroxide. This process takes place under the condition that free fatty acid has to be removed from oil (the quantity of free fatty acid should not exceed 1%). At present, there are a number of technological development of biodiesel such as;

- Basic production process,
- Transesterification by continuous deglycerolization process,
- Transesterification by lipase enzyme,
- Supercritical methanol transesterification,
- Transesterification by microwave,
- Transesterification by solid catalysts,

**2) Esterification** is a reaction between fatty acid and alcohol, with sulfuric acid as catalyst. A process which combined esterification and transesterification under a single production process has been developed. It is called two-stage process, which can be applied with any materials with high fatty acid. In the first stage, free fatty acid is used in esterification. Then the acid is removed and neutralized. In the second stage, a subsequent reaction of transesterification with alkaline catalyst takes place. Moreover, there is a development of solid catalysts, including lipase enzyme, to replace sulfuric acid catalyst which caused



erosion problems for the production system. Furthermore, other than the 2 reactions mentioned above, sophisticated technologies for biodiesel production have been developed, including using algae to produce fuel and hydrogenated biodiesel (using hydrogen gas to transform triglyceride and fatty acid as fuel).

As for biodiesel, the potential materials for producing biodiesel include oil palm, *Jatropha curcas*, coconut, used vegetable oil. The material with highest potential is palm oil. *Jatropha curcas*.

Plantation is expensive and attractive to farmers. There is also a high cost of biodiesel production. Coconuts have issues of high volatility in price and high cost of collecting materials. Used vegetable oil is so limited in quantity that it is insignificant.

Technologies used in each process of biodiesel production from various materials are illustrated in Figure 20. Current technologies and technologies under development are both presented. The technologies that use transesterification reaction include those that use catalyst, such as conventional process (base/acid catalyst), continuous deglycerolization, lipase-catalysis, and microwave, and those that do not use catalyst, namely supercritical methanol. As for esterification reaction, there are batch and continuous reactions. Once raw materials has gone through reaction, the output compounds from the chemical reaction are divided into 2 parts, namely raw methyl/ethyl ester which will be purified to meet biodiesel standards, including separation of residue alcohol for recycle, and raw glycerol which is a by-product and can be purified and marketed.

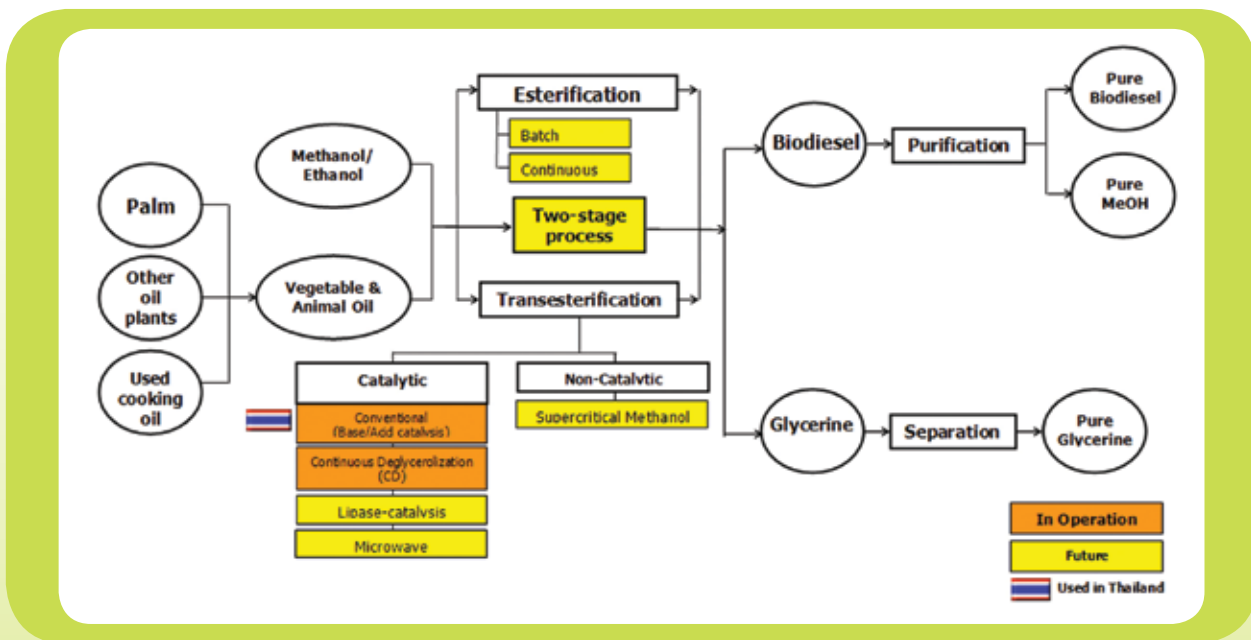

Figure 20 Status of Biodiesel Production Technologies [15]

## Research and Development on Biodiesel Technology

Current research on ethanol technologies is related to various processes, including increasing efficiency in farming methods of raw materials and ethanol production process, ethanol and research on impact from using ethanol in automobile, as well as ethanol promotion. From a review of the research on biomass energy during 1996-2012, it is found that there are 278 pieces of research related to biodiesel. There are 3 main institutions that conduct research on biodiesel. Prince of Songkla University, which is located close to the source of oil palm in the South of Thailand, has the highest number of research. Chulalongkorn University and Kasetsart University are the other 2 institutions with a high number of research. The research and development on biodiesel can be divided into 4 groups.

- **Group 1** : research on the potential of raw materials focuses on the overall potential of materials which can be used to produce biodiesel such as research on area's potential for plantation, logistic management for raw material collection for biodiesel production, and efficiency improvement of raw material production such as genetic improvement. Moreover, an analysis on new materials with potential for new generation of biodiesel is also undertaken, such as *Jatropha curcas* and algae.

- **Group 2** : research on biodiesel production technology focuses on improving production process and increasing efficiency in biodiesel production from various materials.

- **Group 3** : research on the use of biodiesel in automobile focuses on the impact on the engine from using a mixture of biodiesel and diesel in various ratios, as well as supporting biodiesel use in agricultural machines and other vehicles, such as fishing boats.

- **Group 4** : research on economics and environmental impact of biodiesel production focuses on the cost and environmental impact, especially from the pollution created from biodiesel production from various materials and technologies. This includes ways to reduce cost and impact from biodiesel production.

Most researches in Thailand fall under Group 1 and 2, as studies focus on identifying potential of raw materials in producing biodiesel, and on efficiency improvement for biodiesel production process from various materials, especially non-food materials. Meanwhile, researches that fall under Group 3 and 4 have a comparatively low proportion, especially the research on production cost and environmental impact throughout the production life cycle of biodiesel from various materials.



## Concentrations of Research and Development on Biodiesel Production can be divided into 5 aspects.

**Firstly, development in genetics and cultural control of plants for biofuel production involves the following research topics;**

1) 1. Development and modification in plant genetics, such as oil palm, *Jatropha curcas*, and small algae that yield oil products. Selection and modification of genetics use both traditional and applied biomolecular technology, such as marker-assisted selection, to get the most suitable ones for Thailand,

2) Development in crop cultural control and technology transfer on plantation, cultivation, maintenance to farmers in order to reach GAP standards,

3) Area management with precision farming, including the use of GIS technology in planning for farming,

4) Setting production and promotional plans of oil palm plan at a balanced level to maintain price stability of the materials, as well as increasing yield per area to prevent problems with cultivation areas.

**Secondly, logistics development for material collection and transportation involves the following research topics.**

1) Selection of energy crops suitable for biofuel production by using information on material potential such as yield per area, growth rate, cultivation cost, utilization probability.

2) Study for suitable collection method by considering the quality of delivered materials and the locations of plantation areas along with the locations of biofuel factories, as well as the cost of transportation per unit.

**Thirdly, development of production process and prototype factories in order to use materials efficiently and to reduce costs involves the following research topics;**

1) Development of biodiesel production process from oil palm that is integrated with vegetable oil extraction process to be further extended towards design and construction of such factories,

2) Genetic improvement for oil palm by traditional genetic technology and molecular biology, as well as plantation area management,





3) Development of biodiesel production process with new technologies that can transform materials with high level of free fat acid, such as using catalysts or enzyme that can be reused,

4) The expansion of the utilization of crude glycerol resulting from biodiesel production, such as production of biogas or value-added chemicals, as well as developing glycerine purification for a wider industrial uses, and research and development on recovering alcohol used in biodiesel production and utilization of the glycerin by-product to reduce production costs,

5) Development of new palm oil extraction process without using steam – this process can be utilized by smaller factories at community level.

**Fourthly, development of basic research for efficient and sophisticated biodiesel production technologies involves the following research topics;**

1) Research on biodiesel production with microwave and new catalysts,

2) Development of small prototype factories using new efficient technologies in order to study and to collect engineering data,

3) Development of new materials with potential for biodiesel production, such as algae, as well as related technologies, including production and genetic improvement.

**Fifthly, research on policies, especially on cost and ways to reduce ethanol production costs, including promotional measures for greater use of biodiesel involves the following research topics;**

1) Research for suitable cost structures for both raw materials and biofuel;

2) Research for suitable management of demand and supply of each raw material and biofuel.;

3) Development of guidelines management and approaches to ensure the sustainable biofuel industries with no impact on food security and land use.



## Conclusion

**R**esearch and development on energy conservation in the past 15 years focused on energy conservation technologies for buildings, which has a significantly higher proportion than other economic sectors. This is because building energy efficiency is rather complicated and dependent on many variables, including building structural design and the design of other systems such as air-conditioning, ventilation, and lighting systems. It also involves technologies of the equipment and materials, as well as human behavior. The design of such system will have to be suitable for the location and climate of each country. In other words, the building technology which is successful in other countries may not be applied directly with the cases in Thailand. Meanwhile, the research and development on energy conservation technologies in industrial and transport sectors are limited in number despite the fact that these 2 sectors account for 70% of the end-use energy consumption of the country. Moreover, highly efficient equipment and automobile technologies are mostly registered by foreign companies. Therefore, most of the research in these 2 economic sectors focus only on development of supporting technologies to allow for a more efficient use of foreign energy conservation technologies. Moreover, the research on policies is important. It is necessary to conduct the research on policy design and



implementation plans for measures in a way that is related to the technological progress to ensure that energy consumption is most efficient.

At present, research and development on energy conservation technologies in industrial sector in Thailand are limited as there is a need to rely on foreign technologies as previously mentioned, especially industry-specific technologies. There is a need to import the whole process in a turn-key manner. This makes Thailand lack engineering competitiveness in developing technology domestically, except for flour, sugar and food processing industries, as well as the design and construction of cooling systems. As for cross-cutting technologies, Thailand has to primarily rely on imports, especially compressors and water coolers. Thailand currently can manufacture and assemble medium-sized boilers, water pumps, fans, and motors. These machines are installed in medium and small factories. As for large factories which are usually owned by transnational corporations, highly efficient machines are imported, and local personnel receive technological knowledge transfer. Therefore, most large factories are already energy efficient. Most of the locally produced machineries are manufactured with lack of adequate knowledge application. Manufacturing relies on copying with the emphasis on safety standards. The machineries are, therefore, energy inefficient. Promotions through technologies and policies are needed for domestically produced and assembled machineries to be more efficient. This not only promotes energy conservation, but also helps small and medium-sized industries be more competitive and able to survive in the market.

Combined heat and power (CHP) system is a highly efficient technology that can help improve Thailand's energy efficiency. There are 2 types of suitable CHP technology, namely gas turbine technology and gas engine. The manufacturing of gas engine and gas turbine prime movers, and power generators are mostly done by few renowned companies in the developed world. Developing countries that have some roles include China and India. Thailand still needs to import these technologies from other countries. Therefore, the gap in research and development that exists in Thailand is on waste heat and the design of control system and on optimization of system operation.

**Engineering and technological research and development that Thailand should promote to improve energy efficiency in the industrial sector include the following topics;**

(1) Applied research that combines electrical and heat-producing applicants, such as motor systems that combine motor control and moving equipment, and steam systems that combine boiler and other steam equipment,



(2) Applied research helps Thai manufacturers of electrical and heat-producing appliances develop products, such as motors, water pumps, and boilers, which are more efficient than the minimum energy performance standards (MEPS),

(3) Applied research in industrial process control, waste heat recovery, as well as setting up industrial benchmarks for each industry,

(4) Studies on technical aspects and the economics of fuel switching, and the use of CHP system to save energy and to reduce pollution. This will be crucial to handling a rising oil price.

Research and development in commercial and residential buildings should be supported scientific and technological issues that seriously deal with buildings. The buildings that were built in the past 60 years are not suitable for humid climate. There is a high burden from air-conditioning, and an overreliance on artificial light during daytime in spite of adequate availability of daylight. This leads to a high and increasing electricity consumption. Meanwhile, knowledge from current researches informs us that there are potential and opportunities in the design and construction of buildings that have much higher energy capacity and more efficiency than the existing ones. Scientific and technological researches will contribute to knowledge building on overall energy consumption in buildings, economic analysis of overall energy efficiency of buildings. There should also be researches for new ways to increase energy efficiency of systems and equipment, as well as researches on building structure, building shape, bearing, climate, and economic analysis of energy efficiency of buildings, energy efficiency of building structure, and thermal system and air-conditioning. Moreover, researches on lighting and the use of natural light should be set for targets of knowledge and research ability that can lead to the development of a system and design for buildings and meet energy efficiency requirements in practice. Furthermore, research on policy on and support for energy conservation management in buildings is essential for status monitoring and finding new ways to increase effectiveness in energy conservation management within buildings. Development, improvement and reforms of energy efficiency standards management for buildings and system, especially implementation of energy efficiency standards for new buildings and old buildings under renovation

Research and development on energy conservation technologies in transport sector in Thailand has been limited, considering the energy consumption share of the transport sector. This is partly due to the fact that Thailand does not directly own the automobile technologies. The automobile industry in Thailand only involves production of automobile parts and assembly. Engine technologies belong to foreign firms. Nevertheless, an increase in energy efficiency of automobile can be undertaken through using energy efficiency standards measures and through providing tax incentives for using energy efficient cars. These measures



require policy research in order to obtain data for an effective policy implementation, as well as monitoring and evaluation. Moreover, the transport infrastructure of Thailand gives priority to road transport, which is an energy inefficient mode of transport. Therefore, more researches are needed to create knowledge on developing a highly energy efficient transport infrastructure. Technologies that help reduce energy consumption and greenhouse gas emission in transport sector can be divided into 4 groups according to ASIF principle, namely (1) avoid or reduce traveling, such as video conference, online traffic information technology, (2) shift mode of transportation, such as developing bus rapid transit (BRT) and supporting non-motorized transport system, (3) improve vehicle efficiency, such as promoting eco-cars, hybrids, and electric cars, (4) fuel choice in highly efficient fuels.

As for research and development on alternative energy during the past 15 years in Thailand, researches are focused on 5 renewable technologies, namely solar, ethanol, bio-diesel, biomass, and biogas. Research on solar energy accounts for one third of all research, followed by ethanol and biodiesel, accounting for 20% each, biomass for 12%, and biogas for 9.5%.

Research and development on ethanol and biodiesel are similar in that the researches are concentrated in upriver and midstream issues. In other words, most studies focus on identifying potentials of raw materials in producing ethanol and biodiesel, and on efficiency improvement for ethanol production process from various materials, especially non-food materials. Meanwhile, researches on downstream and policy issues have a comparatively low proportion, especially the research on production cost and environmental impact throughout the production cycle of ethanol and biodiesel from various materials. There are 3 main institutions that conduct research on ethanol, namely Chulalongkorn University, KhonKaen University, and Chiang Mai University. Meanwhile, there are 3 main institutions that conduct research on biodiesel, namely Prince of Songkla University, Chulalongkorn University and Kasetsart University. Support for research and development for ethanol and biodiesel production can be divided into 5 aspects: (1) development in plant genetics and crop cultural control management for biofuel, (2) logistics development for material collection and transportation, (3) development of production process and prototype factories in order to use materials efficiently and to reduce cost, (4) research and development to produce ethanol from cellulose with efficient, sophisticated technology development of basic and research for efficient and sophisticated biodiesel production technologies, (5) research on policies, especially on cost and ways to reduce ethanol and biodiesel production cost, including supporting measures for greater use of biodiesel.



Researches related to biomass technologies involve many processes such as biomass preparation prior to energy production, process which transforms biomass into energy, and electricity or heat generation process. There are 4 main institutions that work on renewable energy, namely King Mongkut's University of Technology Thonburi, Naresuan University, Kasetsart University, Chulalongkorn University. Most of the research in Thailand focuses on improving the process of producing energy from biomass, including developing and improving efficiency of technologies for producing energy from biomass. There are also a number of researches that focus on identifying potential of biomass in being raw materials for energy production and on searching for new materials, as well as finding a way to improve the quality of biomass to be more efficient for production. The research on the cost and environmental impact from biomass production is comparatively limited. This group of research focuses on cost analysis of energy production and ways to reduce such costs. The future research related to biomass technology that should be promoted can be divided into 4 groups namely biomass resources, development on fuel preparation, research and development of appropriate technologies that transform biomass into energy, and capacity development of personnel and domestic equipment.

Solar cell technology can be divided into 2 parts, namely solar cell technology and the solar cell system technology. For solar cell technologies, crystalline silicon technology is still the most efficient technology when compared to the thin film technology. There are 5 groups of solar cell technologies, namely crystalline silicon technology (c-Si or wafer based c-Si), thin film technology, emerging technologies, concentrator technologies (CPV), and novel PV concepts. As for the trend in global market share, crystalline silicon technology still has the largest market share. However, the thin film technology has a rapid technological development and is likely to gain more market share quickly, depending on the improved longevity, cost, and efficiency.

In Thailand, crystalline silicon technology has long been commercially available, with established confidence in its quality. As a result, there are limited development gaps among countries. There are rooms for development in cost reduction and quality improvement in the industrial production process. Thin films Si has been produced and developed to some extent in Thailand. Nevertheless, there remains considerable gaps for development choices. Emerging technologies still require prototype development and demonstration as solar cells. Concentrator technologies may have been tested and demonstrated. However, there are obstacles in terms of cost, technological complexity and the pattern of solar radiation in most area of Thailand. Novel PV concepts are the group which deserves to be promoted so that Thai researchers develop their knowledge and stay current with the international progress.



Considering the research and development infrastructure for solar cell technology and the industrial development in Thailand, it is founded that crystalline silicon and silicon thin film have the highest technological potential for industrial development both in terms of efficiency and production process improvement. This may help lowering the production cost of solar cell, increasing the efficiency of cells and cell systems, and improving longevity. Considering the power producing technologies with solar cell, solar system technology in Thailand in the past focused on off-grid technologies. Given that there is now more clear policy on electricity purchasing from solar systems, development and deployment of grid-connected inverters and those for centralized systems or PV power plants can be increased. Thailand's electronic industry has a strong industrial competitiveness and a firm ability in research and development of equipment (balance of systems), both off-grid and on-grid. Apart from the development of equipment for solar systems, Thai researchers also have the capacity and the commitment to undertake research on solar system technology, such as research on the impact of connecting solar systems to power grid, the engineering design of solar systems, standards testing for solar products and systems. Research on these matters will need to be undertaken over time.

Solar water heating technologies consists of 2 parts, namely solar collector and hot water tank. Solar collector is not a complicated technology. It uses the principle of heat absorption and transfer the heat to water or to other types of heat transfer fluids. Solar collector technology can be divided into 4 categories, namely flat plate collector, evacuated collector, CPC collector, and parabolic trough collector. Flat plate and evacuated tube solar collectors are widely used in Thailand. Both technologies are durable, efficient, similarly priced, and mostly imported. Only flat plate collector is produced domestically. At present, a super selective coating substance for solar panel has been developed to increase flat plate panel's efficiency and the output temperature to be comparable to that of the evacuated collector.

The use of wind turbines to generate electricity mostly involves using secondary data to calculate and evaluate projects using statistical methodology. Wind turbine technology can be divided into 2 groups, namely design technology and power control system for wind turbine, and technology for producing wind turbine. The design of wind turbine in Thailand mostly uses the standard airfoil section. The airfoil section developed by international research institutions is registered for intellectual property rights.

As for the power control system for wind turbines, Thailand is only in the early stage, as domestic producers only have experience with small wind turbines which do not require power control system. The larger wind turbines (50 kW) are only in an experimental stage.



Small hydropower can be divided into 3 sizes according to their production capacities, namely small hydropower with 1-30 MW capacity, mini hydropower with 200 kW - 1 MW capacity, and micro hydropower with capacity less than 200 kW. Power generator of a hydro power plant is similar to that of other types of power plants. The most popular types of generator are synchronous generator, induction generator, and permanent magnet generator. In Thailand, it is agreed that the responsibility for developing hydropower sources for small and very small power generation is divided among 3 agencies, namely the Electricity Generating Authority of Thailand (EGAT), the Provincial Electricity Authority (PEA), and the Department of Alternative Energy Development and Efficiency (DEDE). It is agreed that for a project which is financially feasible, EGAT or a private company will undertake project development. DEDE will undertake projects which are socially feasible, but not economically, with capacity no greater than 6 MWe. The projects will also need to be located outside national parks and wildlife sanctuaries. Thailand currently has experience exploring for hydro power sources, structural design, and construction of small and large dams with capacity over 100 MWe. However, there is a low capacity in designing, constructing and manufacturing hydropower turbine and electromechanical systems.

The technologies for energy from wastes can be divided into 8 groups, namely Incineration technology, gasification technology, pyrolysis technology, plasma arc technology, RDF technology, anaerobic digestion technology, landfill-gas-to-energy technology, and bioreactor-gas-to-energy technology. Research and development on energy from waste technologies can be divided into 3 groups. First group is anaerobic digestion technology, landfill-gas-to-energy technology, and refused derived fuel (RDF). This group of technology is ready and suitable for the wastes in Thailand. They can be used with small (less than 100 tonne/day) to medium (100-250 tons/day) sources of waste. These technologies require a waste management system. Even though the energy produced per unit is not extensive, but the technologies can be dispersed to a range of locations. Limitations of the technologies include waste separation for anaerobic digestion, which will be suitable for fresh markets and cafeterias. On the other hand, RDF needs to be located near to sources of waste and needs a waste separation system. Second group is incineration, gasification technology, and pyrolysis technology. This group is mainly thermal technologies. They are popular in other countries as they can handle large quantity of wastes without the need for waste separation. The level of energy produced per unit is higher than other technology. This group of technologies requires a costly investment, but can be used in large to extra large source of wastes. The third group is plasma arc technology and bioreactor-gas-to-energy. This group of technologies is not yet ready for deployment and still in research and development stage with no actual use in Thailand and other countries.





# References

- (1) Ministry of Energy (2011) The 20-year Energy Efficiency Development Plan (2011-2030), November 2011.
- (2) Department of Alternative Energy Development and Efficiency (DEDE), Ministry of Energy (2010), Energy Report of Thailand.
- (3) Joint Graduate School of Energy and Environment, King Mongkut's University of Technology Thonburi (2010), The Study on Formulating Policy of Scientific, Technology and Innovation on Energy, Environment and Related Issues, October 2010.
- (4) Bandit Limmeechok and Team, An Assessment of Cost Effectiveness of Renewable Energy Investment and Energy Saving of the Country, a completed and port, July 2009.
- (5) Aphichit Terdyothin and Team (2007) , An Assessment of Energy Saving Potential and Technology in Industrial Sector under the policy research project on alternative energy and energy efficiency promotion, the Thailand Research Fund.
- (6) Joint Graduate School of Energy and Environment, King Mongkut's University of Technology Thonburi (2011), The Study on the 20-Year Energy Efficiency Development Plan, Final Report, May 2011.
- (7) Surapong Chiratrattananon and Team (2012), The Study on Formulating the Master Plan of Energy Conservation Research in Thailand : Commercial and Residential Sectors.
- (8) Chiratratananon S., P., Hien, VD, Pakkwamsue, P., Kubaha, K (2010), Assessment of Energy Saving from the Revised Building Energy Code of Thailand Energy 35(4): pp. 1741-1753.
- (9) Chiratrattananon S., P., Hien, VD, Tumu, P. (2012), Thermal Performance and Cost Effectiveness of Wall Insulation under Thai Climate, Energy and Buildings 45:pp. 82-90.
- (10) Schipper, L., et.al.(2000) "Flexing the Link between Transport and Green House Gas Emission: A Path of the World Bank," International Energy Agency, Paris.
- (11) Chamnong Sorapipat and Team (2012), The Study on Setting Up the Master Plan on Energy Conservation Research of Thailand: Transport Sector.
- (12) International Energy Agency (2010), Paris, Transport Energy Efficiency
- (13) Department of Alternative Energy Development and Efficiency (2012), Alternative Energy Development Plan : 25% in 10 Years (2012-2021), Department of Alternative Energy Development and Efficiency, Ministry of Energy.
- (14) Ministry of Energy and Ministry of Sciences and Technology (2011), Implementation Plan on Policy Application of Sciences, Technology and Innovation to Support the Alternative Energy Development in Thailand.
- (15) Joint Graduate School of Energy and Environment, King Mongkut's University of Technology Thonburi (2010), The Study to Set Up Policy on Science, Technology and Innovation : Energy and Environment Relating to Energy, National Science Technology and Innovation Policy Office.
- (16) The Thailand Research Fund (2007), Research on Policy Supporting the Renewable Energy and Energy Efficiency Development and Consumption in Thailand, Energy Policy and Planning Office, Ministry of Energy.
- (17) Pamornrat Prasobchok (1989), The Feasibility Study on Electricity Generation form Wind : the Case Study of Wind Power Plant, Pangan Island, Suratthani Province.



# Working Group

## Advisory Team

DR. TWARATH SUTABUTR  
DR. PRASERT SINSUKPRASERT  
MR. MANASWEE HAKEME  
MISS JARASPHAN PHUMPUANG  
MR. RUANGDET PANDUANG  
MR. WANCHAI BUNLEUSINTH  
MISS SUCHITRA YEN-ENG

## Researchers, College of Innovation, Thammasat University

MR. TIRIN NA THALANG  
DR. KAMOLBHAN SANGMAHACHAI  
DR. SURACHAI SATHITKUNARAT  
MR. ATIP HITACHAD  
MISS RUNGRAWEE LORSONG  
MISS PATCHARANAN PONGSATITTHAM

