



Railton, C. J. (2015). A Rotated Subgrid for 3D FDTD. In 2015 IEEE International Symposium on Antennas and Propagation & USNC/URSI National Radio Science Meeting: Proceedings of a meeting held 19-24 July 2015, Vancouver, British Columbia, Canada. (pp. 330-331). (Proceedings of the IEEE International Symposium on Antennas and Propagation & USNC/URSI National Radio Science Meeting). Institute of Electrical and Electronics Engineers (IEEE). DOI: 10.1109/APS.2015.7304551

Peer reviewed version

Link to published version (if available):

[10.1109/APS.2015.7304551](https://doi.org/10.1109/APS.2015.7304551)

[Link to publication record in Explore Bristol Research](#)

PDF-document

This is the author accepted manuscript (AAM). The final published version (version of record) is available online via IEEE at http://ieeexplore.ieee.org/xpls/abs_all.jsp?arnumber=7304551. Please refer to any applicable terms of use of the publisher.

University of Bristol - Explore Bristol Research

General rights

This document is made available in accordance with publisher policies. Please cite only the published version using the reference above. Full terms of use are available: <http://www.bristol.ac.uk/pure/about/ebr-terms.html>

A Rotated Subgrid for 3D FDTD

Chris J. Railton

Centre for Communications Research

University of Bristol

Bristol, England

Chris.railton@bristol.ac.uk

Abstract—In most published work on subgrids for the FDTD method, Cartesian subgrids are proposed which are in the same orientation as the main grid. However there is considerable benefit to allowing for the subgrid to be rotated. In this work, a novel method for introducing a rotated subgrid into the mesh is presented and some preliminary results are given.

I. INTRODUCTION

The Finite Difference Time Domain (FDTD) method has been widely used to characterize antennas and antenna arrays for several decades. Nevertheless arrays in which each element is orientated in a different direction, such as [1], present severe difficulties due to it not being possible to align all elements with the same Cartesian mesh. In [2], a method is presented whereby each element of the array is modeled using a separate Cartesian mesh which can be orientated in the most appropriate way for that element. These separate meshes are then rotated and positioned to match the actual location and orientation of each element in the array. Although good results were obtained, this method makes the approximation that energy is transferred only in one direction, ie. from the excited element to all the non-excited ones and multiple reflections were ignored.

Recently, a full sub-gridding method has been presented which is based upon Huygens and anti-Huygens surfaces [3]. Although the method is effective and flexible, it has been applied only to the situation where all the grids are orientated in the same direction. In [4], the methods of [2] and [3] were generalized and extended to allow application to subgrids which are tilted in 2D FDTD. In this contribution, it is shown that this method can be extended to a full 3D FDTD situation.

II. THEORY

In the proposed method, which is based on [4], a subgrid, which may be rotated, is placed within the main grid as shown in Figure 1. The subgrid, is surrounded by two closed cuboids referred to as the “inner surface” and the “outer surface”. Energy is transferred between the two grids by applying the equivalence principle. Fields impinging on the inner surface from the main grid are replaced by equivalent electric and magnetic currents which are used as excitation sources for the subgrid. Similarly the fields impinging on the outer surface from the subgrid replaced by equivalent electric and magnetic currents which are used as excitation sources for the main grid.

For a tilted subgrid the locations of the nodes in the two grids will generally not coincide and therefore interpolation is necessary. The way in which this is done is a key issue. In Figure

2, part of a cross-section through the boundary between the subgrid and the main grid is shown. The main grid is aligned on the (x,y,z) axes while the subgrid is aligned with the rotated axis (u,v,w). The upper pair of lines form the inner surface and the lower pair form the outer surface. For clarity, the only subgrid nodes which are shown are those on the boundary. The E field nodes are shown by crosses and the H field nodes by circles. This arrangement is similar to the one used in [3] except that here there is no restriction on the angle between the grids and none of the subgrid nodes are collocated with main grid nodes. Time interpolation is done as in [3], space interpolation and distribution is done as follows:

A. The inner surface – interpolation

The inner surface is used to transfer energy from the main grid to the subgrid. For illustration, consider the left hand, $-v$, boundary. The following steps are used:

1. Find the amplitude of the H field in the main grid at the position of each E_u and E_w node on the $-v$ boundary plane using linear interpolation.
2. Find the amplitudes of the equivalent current at these nodes using $\mathbf{J} = -\hat{\mathbf{v}} \times \mathbf{H}$.
3. Rotate the J vector, which is still expressed in (x,y,z) components, to get the (u,v,w) components.
4. Update the E_u or E_w subgrid field amplitude using Maxwell’s equation $\dot{\mathbf{E}} = \epsilon^{-1} \mathbf{J}$. The contribution of curl H to this equation will have already been included using the usual FDTD update equations.

B. The outer surface – distribution

The outer surface is used to transfer energy from the subgrid to the main grid. Again, consider the left hand boundary. The following steps are used:

1. For each E_u and E_w node on the outer surface, find the corresponding equivalent magnetic current using $\mathbf{M} = \hat{\mathbf{v}} \times \mathbf{E}$.
2. Rotate to M vector to find the components in the (x,y,z) directions.
3. For each M_x value, distribute the current between the surrounding H_x nodes using the same weights as were used in the inner surface interpolation. Do the same for H_y and H_z .

- Update the main grid nodes using $\dot{\mathbf{H}} = \mu^{-1} \mathbf{M}$ where, again, the curl E will have already been included during the normal FDTD updates.

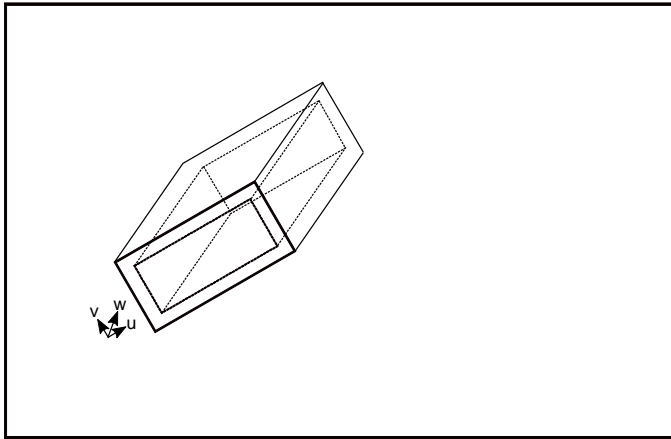

Figure 1 A tilted subgrid surrounded by two Huygens surfaces

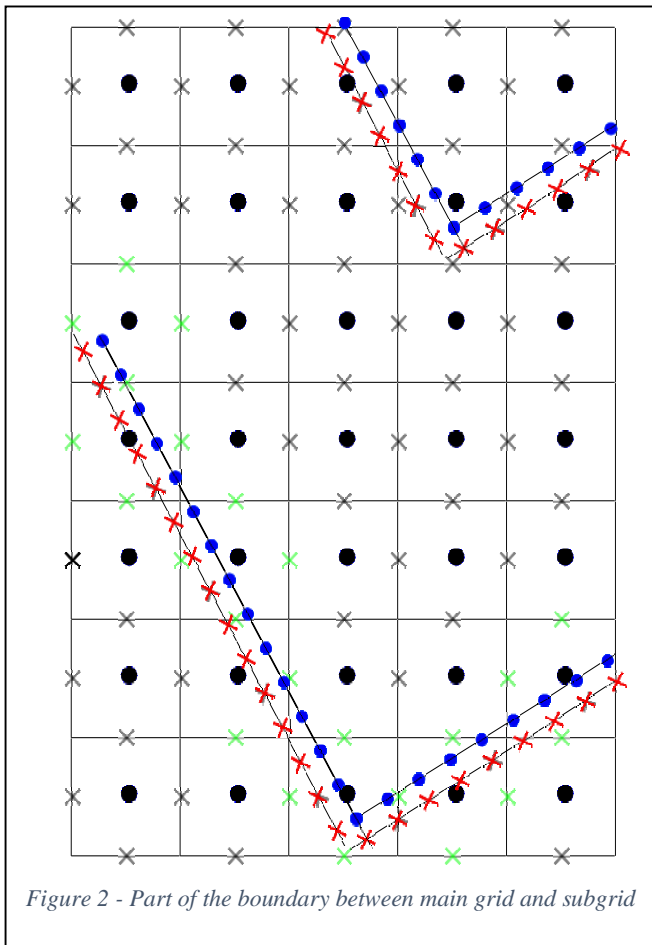

Figure 2 - Part of the boundary between main grid and subgrid

III. RESULTS

As an example, the resonant frequency of a rectangular cavity rotated by 30° about the z-axis was determined. The cavity

was excited with an incident plane wave, launched in the main grid, by means of a small aperture in the cavity wall. The lowest resonance frequency of the cavity was found analytically to be 5MHz. For the test, the main grid cell size was 3mm, the subgrid cell size was 1mm. The subgrid was rotated by 30° so that it was lined up with the cavity. In addition, tests were done using single meshes with cell sizes of 3mm, 1mm and 0.3mm. Fourier transforms of the field in the cavity under these different conditions are shown in Figure 3. It can be seen that the subgrid gives an accurate result whereas for all the single meshes, although the accuracy does improve for smaller cell sizes, the result is not good. This is largely due to staircasing error which is eliminated by using the rotated subgrid.

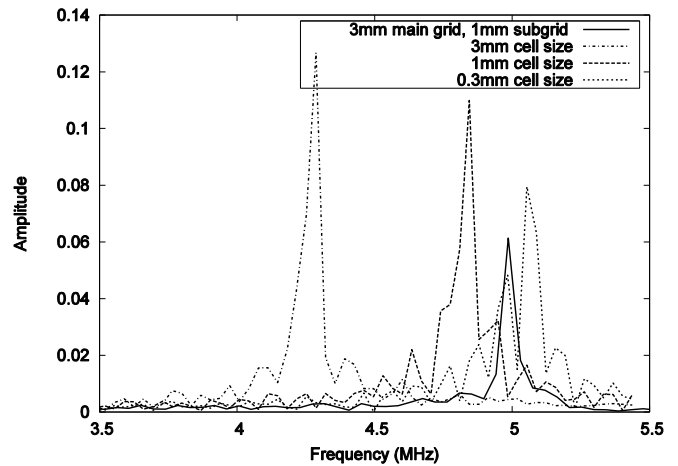

Figure 3 - Fourier Transform of the fields in the resonant cavity

IV. CONCLUSION

A novel rotated subgrid scheme for FDTD has been presented and preliminary results given which indicate the effectiveness of the method.

ACKNOWLEDGEMENT

The author would like to thank his colleagues in the Centre for Communications Research for helpful discussions.

REFERENCES

- [1] M. Klemm, J. Leendertz, D. Gibbins, I.J. Craddock, A. Preece, R. Benjamin, "Towards Contrast Enhanced Breast Imaging using Ultra-Wideband Microwave Radar System", Radio and Wireless Symposium (RWS), 2010, pp. 516-519
- [2] C Christodoulou, C. J. Railton, M. Klemm, D. Gibbins, I. J. Craddock, "Analysis of a UWB hemispherical antenna array in FDTD with a Time Domain Huygens method", IEEE Trans. On Antennas and Propagation, Vol. 60, No. 11, Nov. 2012, pp 5251-5258.
- [3] Jean-Pierre Bérenger, "The Huygens subgridding for the numerical solution of the Maxwell equations", Journal of Computational Physics, 230 (2011) pp. 5635-5659.
- [4] Chris. J. Railton, "A Tilted Subgrid for Two Dimensional FDTD", To be presented, EuCAP 2015, Lisbon, Portugal.