



Longo, J., De Mulder, E., Page, D., & Tunstall, M. (2015). SoC It to EM: ElectroMagnetic Side-Channel Attacks on a Complex System-on-Chip. In Cryptographic Hardware and Embedded Systems - CHES 2015. (1 ed., Vol. 9293, pp. 620-640). (Lecture Notes in Computer Science; Vol. 9293). Springer. DOI: 10.1007/978-3-662-48324-4_31

Peer reviewed version

Link to published version (if available):
[10.1007/978-3-662-48324-4_31](https://doi.org/10.1007/978-3-662-48324-4_31)

[Link to publication record in Explore Bristol Research](#)
PDF-document

The final publication is available at Springer via http://dx.doi.org/10.1007/978-3-662-48324-4_31

University of Bristol - Explore Bristol Research

General rights

This document is made available in accordance with publisher policies. Please cite only the published version using the reference above. Full terms of use are available:
<http://www.bristol.ac.uk/pure/about/ebr-terms.html>

SoC it to EM: electromagnetic side-channel attacks on a complex system-on-chip

J. Longo¹, E. De Mulder², D. Page¹, and M. Tunstall²

¹ Department of Computer Science, University of Bristol,
Merchant Venturers Building, Woodland Road,
Bristol, BS8 1UB, United Kingdom.

{jake.longo,daniel.page}@bristol.ac.uk

² Rambus Cryptography Research Division,
425 Market Street, 11th Floor,

San Francisco, CA 94105, United States.

{elke.demulder,michael.tunstall}@cryptography.com

Abstract. Increased complexity in modern embedded systems has presented various important challenges with regard to side-channel attacks. In particular, it is common to deploy SoC-based target devices with high clock frequencies in security-critical scenarios; understanding how such features align with techniques more often deployed against simpler devices is vital from both destructive (i.e., attack) and constructive (i.e., evaluation and/or countermeasure) perspectives. In this paper, we investigate electromagnetic-based leakage from three different means of executing cryptographic workloads (including the general purpose ARM core, an on-chip co-processor, and the NEON core) on the AM335x SoC. Our conclusion is that addressing challenges of the type above *is* feasible, and that key recovery attacks can be conducted with modest resources.

Keywords: side-channel, electromagnetic, system on chip, ARM, NEON.

1 Introduction

A significant proportion of academic literature on side-channel attacks *already* targets real-world devices: even a very limited list of examples, such as those against KeeLoq keyless entry systems [20,27], Xilinx FPGA bit-stream encryption [34], or Atmel CryptoMemory [5] authentication, provides compelling evidence of their potency. However, and although clear counter-examples are identifiable, such devices may often be characterised as electronically and/or architecturally simple (the cryptographic aspects at least). From one perspective, this is a non-issue: use-cases such as contact-based and contactless payment cards, and trends such as Internet of Things (IoT) suggest devices of this type will abound for some time to come; the simplicity of a target in no way implies that developing and mounting attacks is simple nor without more general value. However, from a different perspective, it may seem unsatisfactory since it contrasts sharply with trends in commodity micro-electronics. In particular, more complex devices with richer functionality are now routinely deployed in contexts where

side-channel attacks are a threat. For example, smart-phones now house multi-core, System-on-Chip (SoC) components with multi-gigahertz clock frequencies as standard, and, modulo constraints such as energy efficiency, market forces will drive increased use of similar components over time.

Within this context, use of ElectroMagnetic (EM) side-channel leakage is particularly attractive. Rohatgi [38] offers a comprehensive overview of both the physical phenomenon itself plus seminal results such as [3,21,37], neither of which we expand on unless specifically relevant. Versus power analysis [28], the non-contact, spatially flexible nature of an EM-based alternative means it a) represents a less invasive means of taking acquisitions, b) avoids issues such as on-chip voltage regulation and, most importantly, c) permits targeting of specific regions of (or components on) an SoC that otherwise offer composite leakage.

Our goal in this paper is to demonstrate that by carefully translating and refining existing techniques, EM-based side-channel attacks are viable against modern, complex targets. The challenges of evaluation and countermeasure instrumentation already motivate such work, but are arguably magnified by other constructive applications of side-channels (e.g., protection of intellectual property [7] and Trojan hardware detection [19]) relevant to SoCs: *all* benefit from better, *open* (noting this topic seems to represent an active but largely undocumented focus of various security services [40]) understanding of the associated leakage characteristics. We explore a single exemplar target device, namely the Texas Instruments (TI) AM335x SoC on a BeagleBone Black development board, with respect to three options for execution of cryptographic workloads. Following the relevant background material in Section 2, our contribution is, concretely, the EM-based analysis of

1. AES executed by an OpenSSL server on the ARM core (Section 3),
2. the proprietary AES co-processor (Section 4), and
3. the NEON³ core, including bit-sliced AES (Section 5).

A central conclusion is that, while some effort is required to characterise the leakage, attack complexity does not *necessarily* scale in line with perceived device complexity. For example, in the first case above we are able to acquire and exploit leakage at *much* lower frequencies than suggested by the 1 GHz system clock; this implies attack cost may also be lower than expected, and hence relying on device complexity (resp. obscurity) to provide security is dubious at best.

2 Background

2.1 An overview of the BeagleBone platform

BeagleBone Black is a single-board computer built around a AM335x “Sitara” SoC. Constituent components can be grouped logically into four sub-systems per [25, Figure 1-1]; the sub-systems are able to communicate via a dedicated Network-on-Chip (NoC), or interconnect. The following sections focus on the

³ Note that by targeting NEON, we specifically aim to add detail to the premise introduced during the CHES 2014 rump session talk of Bernstein and Lange: see <http://cr.ypt.to/talks/2014.09.25-2/slides-dan+tanja-20140925-2-4x3.pdf>.

Micro-Processor Unit (MPU) and the cryptographic co-processor. Although the latter lacks public documentation of the internal design (bar device driver source code⁴ that interfaces with it), the former warrants further analysis: we refer to the extensive literature⁵ for in-depth coverage.

The central point to take away from such analysis is the high degree of architectural complexity evident, even ignoring the number of components. For example, the MPU alone has a total of 3 clock and 4 power domains. Such features make the SoC an extremely challenging target with respect to Signal-to-Noise Ratio (SNR), and underlines the advantages offered by EM-based leakage.

2.2 Experimental environment

Acquisition and measurement equipment. To allow reproducibility, the equipment used throughout this paper is listed below:

- Tektronix DPO7104 1 GHz oscilloscope,
- Signatec PX14400 400 MS/s digitiser,
- Langer PA303 pre-amplifier plus various (e.g., low-pass) hardware filters,
- Langer RF-3 mini near-field probe set,
- Langer ICS105 IC scanner (or XY-table),
- Matlab 2014b (with signal processing toolbox).

The configuration was therefore very standard: the target device was mounted on the XY-table to allow micro-positioning of the probe(s), which supplied an amplified, filtered signal to either the digitiser (Section 3 and Section 5) or oscilloscope (Section 4, to cope with a higher sampling rate). This limits our remit strictly to close-range acquisitions, rather than at a distance, e.g., per [43].

Software stack. We used a standard BeagleBone Black distribution of Debian “Wheezy” on the target device (Linux kernel version 3.13.3). The device was booted from on-board embedded MultiMediaCard (eMMC) storage as is; no standard system processes were disabled. On top of this platform we use OpenSSL 1.0.1j, with the `cryptodev` extension⁶ enabled when appropriate.

2.3 Leakage detection and exploitation strategy

Notation. For some set or sequence x of length n , we let $x[j]$ denote the j -th element of x such that $0 \leq j < n$; x_i then denotes the i -th such object within a larger collection, with the subscript omitted where irrelevant. We use $\mathcal{H}(x)$ and $\mathcal{D}(x, y)$ to denote the Hamming weight and distance, respectively, of some x and y . As such,

$$r_i = \text{DUT}_k^f(x_i) \rightsquigarrow \lambda_i$$

models some i -th execution of an operation f on the target device DUT, involving a security critical datum k (e.g., key material), accepting input x_i and yielding

⁴ <http://github.com/torvalds/linux/blob/master/drivers/crypto/omap-aes.c>

⁵ http://www.arm.com/files/pdf/A8_Paper.pdf

⁶ <http://cryptodev-linux.org/>

an output r_i and an EM-based trace of leakage λ_i (a sequence of samples). Depending on the context, the target operation ranges from single instructions to entire algorithms (e.g., AES), and, from the attacker perspective, r_i and/or x_i may be known or unknown and controlled or uncontrolled.

λ is essentially a function of the target device (or leakage model), the operation f and input x_i , *plus* the probe type and location (and any other parameters of the experimental environment). With this in mind, mounting a concrete attack demands an attacker a) determines when and where (in time and/or frequency domains) λ contains useful, exploitable leakage, and b) selects a probe configuration to maximise said leakage (i.e., maximise the SNR).

Leakage detection. While several strategies, e.g., [11,12,23], have been proposed to address the former challenge above, throughout this paper we use Welch’s t-test. More specifically, we use the Test Vector Leakage Assessment (TVLA) methodology of Goodwill et al. [23]. Although there are several variants (fixed-versus-random and semi-fixed-versus-random for instance), the basic idea involves constructing two sets of test vectors V_0 and V_1 : the former contains a single (semi-)fixed vector, whereas the latter contains (a large number of) vectors chosen uniformly at random. For each i -th invocation of the target device, the input is selected by first randomly selecting a test vector type, i.e., a $b \stackrel{\$}{\leftarrow} \{0, 1\}$, then a test vector from the appropriate set, i.e., an $x_i \stackrel{\$}{\leftarrow} V_b$; the resulting trace of leakage, λ_i , is added to a set A_b based on the test vector type. Then, we compute the t-statistic trace as

$$t = \frac{\bar{A}_0 - \bar{A}_1}{\sqrt{\frac{\sigma_0^2}{|A_0|} + \frac{\sigma_1^2}{|A_1|}}}$$

where $|A_b|$, \bar{A}_b and σ_b^2 respectively denote the sample size, sample mean and sample variance of set A_b . The idea is that given a threshold τ (say $\tau = 4.5$ per [23, Section 3]), if we find $|t[j]| > \tau$ then we claim significant leakage is detected at the j -th sample: at that point there is a statistically observable difference between fixed and random test vectors, so there may be data-dependent and thus potentially exploitable information present. Each following section uses this approach: section-specific detail is included where appropriate, with a comprehensive overview deferred to the full version of this paper [29, Appendix A].

3 Software-based AES

In the literature, it is common to target embedded devices (e.g., a micro-controller) executing a program on “bare-metal”, i.e., directly on the hardware. Although reasonable for some scenarios, a growing number of targets will execute an Operating System (OS) kernel; this is even true of many smart-cards (cf. JavaCard or MULTOS). Perhaps due to the perceived increase in complexity, related attacks are less common than the bare-metal case: selected examples include Uno et al. [42] and Genkin et al. [22] who mount non-differential EM-based attacks on

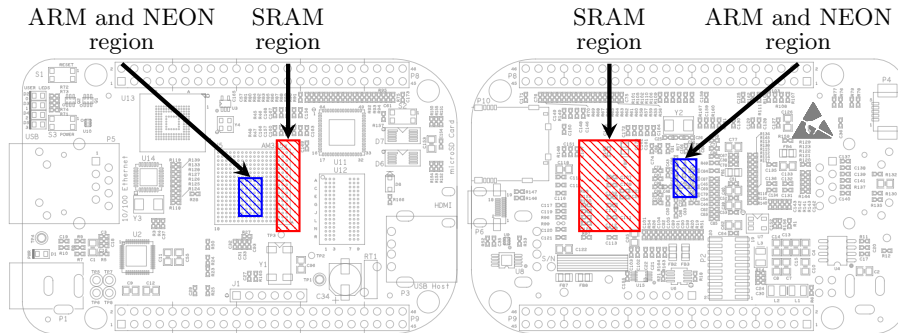

Fig. 1: BeagleBone Black schematic (source: http://github.com/CircuitCo/BeagleBone-Black/blob/rev_a5c/BBB_PCB.zip) from front-side (left) and back-side (right), annotated with probe locations for leakage from the SRAM (red) and ARM and NEON cores (blue).

RSA (plus ElGamal in the latter case only) executing under Android (on ARM) and Windows XP (on x86), Aboukassimi et al. [1,2] who mount differential EM-based attacks on AES executing under Java ME (on ARM), and Pellegrini et al. [35] who mount voltage depletion fault attacks on RSA executing under Linux (on SPARC).

In this section we consider a systems-oriented scenario of the latter type. Specifically, we imagine the target is a communications device (e.g., a smartphone) engaged in a TLS-based session with some server. As such, the attacker can observe computation of

$$c_i = \text{DUT}_k^{\text{AES-128-CBC}}(m_i) \rightsquigarrow \lambda_i.$$

That is, AES-128 encryption, in CBC mode, of some unknown plaintext m_i under k to yield a known ciphertext c_i (since it is communicated across the network). Concretely, each encryption operation is performed by OpenSSL in software via the default T-tables-based [14, Section 4.2] implementation.

3.1 Experimental outline

Before considering an attack strategy to exploit λ and recover k , a host of experimental challenges need to be addressed: the first relates to acquisition of λ . In common with analysis of other unknown/as yet unprofiled target devices, we rely on initial exploration based on full control of a replica profiling device. We stress that our use of the profiling device is simply to give insight into the associated signal characteristics: although it is well known that such an approach is not necessarily sufficient for building templates [13], we simply use it to mitigate systemic features (e.g., of the OS scheduler, hardware and software interrupts etc.) inherent in the scenario above.

Probe location. An initial, manual scan of the SoC surface was conducted in several stages to identify leakage related to the execution of three kernels: a

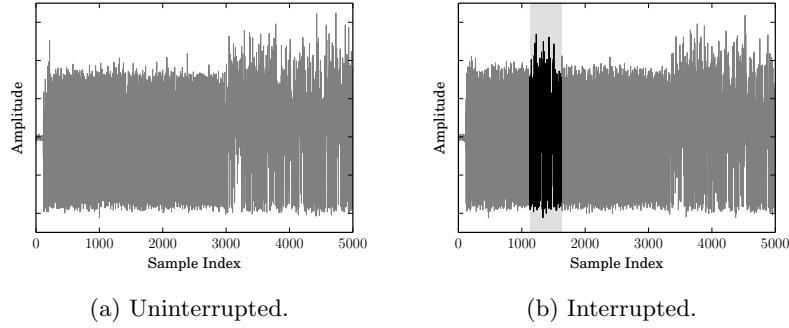

Fig. 2: Impact of interrupts on the acquisition process in Section 3: whereas the uninterrupted case (left) yields a “clean” trace, the interrupted case (right) is corrupted (during the annotated period).

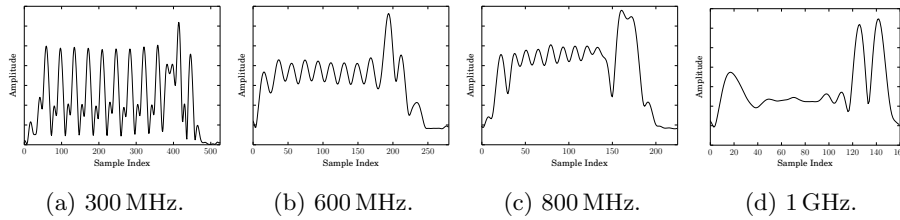

Fig. 3: Impact of clock scaling on the acquisition process in Section 3: each trace represents execution of AES under one of the four available clock frequencies.

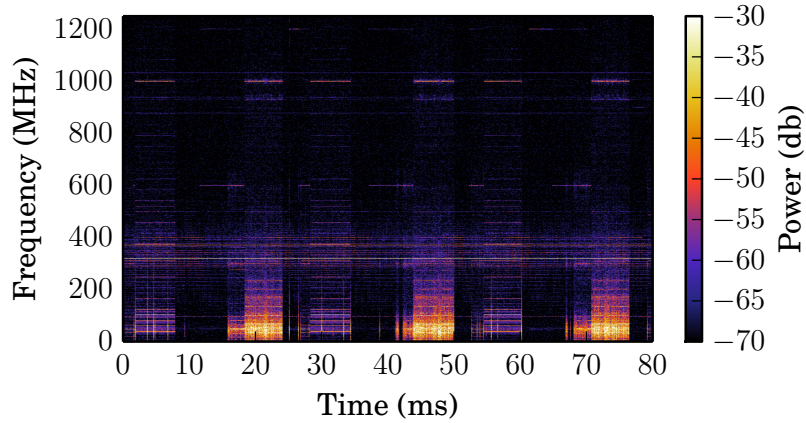

Fig. 4: Spectrogram plot of frequency band 0 to 1.25 GHz at our attack location, with the profiling device cycling through three kernels: a total of three iterations (left-to-right) of the memory intensive, spin-lock and computational (i.e., AES) kernels is illustrated. Note a) the indicative frequency response of AES, and b) the relatively narrow, low frequency range required to capture this response.

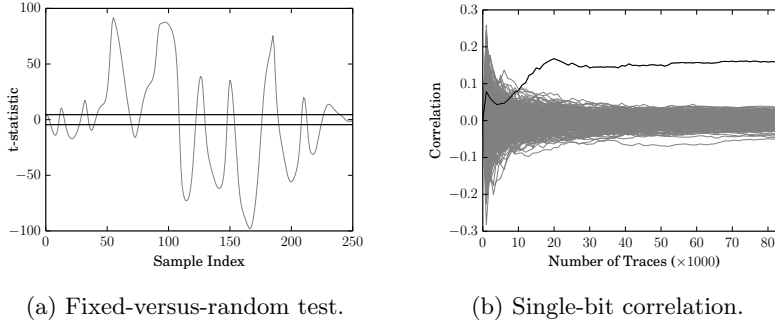

Fig. 5: Leakage analysis results for a free-running target using 85,000 sub-traces matched at 600 MHz. The leakage detection test (left) shows leakage above the significance threshold $\tau = 4.5$ (marked in black on the Y-axis) throughout the AES execution. The single-bit analysis (right) tracks the correct key bit hypothesis of the first byte over the number of sub-traces used.

set of memory intensive operations, a spin-lock, and a set of computationally intensive operations (namely AES encryption, as performed by OpenSSL). By periodically cycling through the kernels and monitoring the frequency response (illustrated by Figure 4), two distinct regions of interest were identified (shown in Figure 1). We attribute one region (straddling the SoC edge and SRAM bus) to the memory intensive kernel, and hence memory access. Given that the memory bus is specific to this development kit, that no effort appears to have been made to secure it, and that a complete operational datasheet is available⁷, we did not feel it warranted further investigation even though it will likely yield exploitable leakage. The second region is located centrally on the AM335x surface, over a cluster of capacitors on the back-side of the board (specifically, around C94 and C46). Motivated by a) the magnitude of the frequency response observed during the AES execution, but also b) the long-term trend toward stacked fabrication processes (and associated decrease in SNR), we fixed the probe location over this support circuitry.

Acquisition tuning. The leakage from the selected region was identifiable using relatively low frequencies alone, i.e., below 100 MHz. We expect this, to some degree, since a) AES throughout is clearly lower than the system clock frequency (one round is requires more than one instruction), and b) the on-chip discrete components coupled with the capacitor behave as a low-pass filter. As such, we applied a band-pass filter to the amplified signal centred on 45 MHz with a bandwidth of 24 MHz. This is interesting in so far as it allows use of less capable, and hence less expensive acquisition equipment. That is, rather than use a high-specification oscilloscope, we were able to use a lower-specification digitiser.

Bulk, or multi-block acquisitions. Our next step was to replace the artificial kernels with a “free-running” uninstrumented OpenSSL client instance: no artificial

⁷ <http://www.micron.com/parts/dram/ddr3-sdram/mt41k256m16ha-125>

(e.g., hardware, via a GPIO pin) triggers are inserted. A coarse, soft trigger is attractive, but strictly to limit acquisitions to a target session (i.e., one k) rather than to provide alignment per se: each trace λ_i acquired therefore relates to l invocations of AES rather than 1, i.e., each c_i is now a $(16 \cdot l)$ -byte or l -block ciphertext, as generated by the TLS record layer. Such a soft trigger is easily realised via traffic analysis, and is additionally beneficial since it permits c_i to be known (i.e., sniffed) rather than controlled (i.e., injected) by the attacker.

Although we argue that this choice is more realistic than the alternative, it has both positive and negative effects. On one hand, bulk acquisition significantly reduces the wall-clock time required [6, Section 3] and allows the effect of data and instruction caches to be largely ignored (since all but the first few AES invocations will occur with a warm cache). On the other, we must address various challenges relating to systematic noise that occurs over the longer time period (and which for “one-shot” devices such as smart-cards, are normally irrelevant).

Interrupt detection and synchronisation. The OS may preempt a user process if it does not voluntarily yield, or if the kernel needs to service an interrupt: use of bulk acquisition necessitates we account for these interrupts, because they will be observed more frequently during the computation of longer ciphertexts.

Figure 2 demonstrates that an uninterrupted versus interrupted trace can be identified visually. We *automate* similar identification using the trace alignment scores (i.e., a measure of the least squares [31, page 208]). To do so, we manually identify and select a single uninterrupted trace for use as a template. We then perform coarse alignment of all traces and record their score (versus the template): if the score is above an experimentally determined threshold, the trace is assumed to have been interrupted. For interrupted traces, we then have two choices: discard them, or “clean” them by pruning the interrupted region. We found the low sample rate used means interrupt pruning is highly error prone (it is not always clear at which exact point the interrupt has ended and the OpenSSL process has resumed); such errors desynchronise the trace (i.e., the sub-trace for a given AES invocation) from the associated ciphertexts. Although discarding traces imposes a penalty on the total number of traces required, we opted for this approach.

Clock scaling. Finally, the OS may attempt to scale (or throttle) the clock frequency to optimise power consumption. We observed cases where this occurred, although found the device would typically stabilise at 600 MHz once the OpenSSL process becomes active. AES execution under each clock configuration is shown in Figure 3, with the difference between cases clearly highlighting the resulting misalignment.

By sampling well above the Nyquist rate, it may be possible to *infer* the clock rate by examining the response at specific frequencies (i.e., at 300 MHz, 600 MHz, 800 MHz and 1 GHz); such an approach may also facilitate interrupt pruning (per the above). However, use of a low sampling rate, while advantageous in other respects, rules this approach out. Instead, we simply created a template of AES execution at each clock frequency: any trivial comparison between each

template and target trace reveals the clock frequency used, and yields a usable subset of traces whose clock frequency is uniform.

3.2 Analysis and discussion

Summarising the section above, to mount a concrete attack we performed an acquisition phase as follows:

1. Bulk acquire $n = 1,000$ traces, each including $l = 256$ encryption operations (meaning 4 kB of traffic per trace, and ~ 4 MB in total).
2. Deal with systemic noise by filtering for interrupts and clock scaling; in our experience, this means discarding $\sim 20\%$.
3. From each remaining trace, extract a fragment or sub-trace for each encryption operation; match these with the associated ciphertexts.
4. Realign each sub-trace, and discard any corrupted or low-quality cases; in our experience, this means discarding a further $\sim 5\%$.

This process yields a set of $s < n \cdot l$ remaining (sub-)traces, and for such n and l took ~ 6 min. Based on this set, we then attempted to exploit the leakage. To do so, we mounted a single-bit correlation-based attack targeting the T-table (or S-box) look-up in the final AES round. Figure 5b illustrates, without loss of generality, an example for the first byte of k : it shows growth of the correlation coefficient as the number of (sub-)traces increases. Note the correct (highlighted) hypothesis is clearly distinguished using around 20,000 (sub-)traces, meaning we *could* have bulk acquired as few as 100 traces (~ 400 kB) and still have been successful. In reality, fine-tuning n before the acquisition phase is difficult since the attacker cannot control l (and indeed this may change from one trace to another). However, using an adaptive choice of n such that s is large enough, the attack still succeeds.

We benchmarked this attack against a traditional alternative where an artificial hardware trigger (which simultaneously aligns traces, and avoids the issue of interrupts) and fixed clock frequency were used. We found key recovery was possible with only 3,000 (sub-)traces, ~ 7 times fewer than our free-running scenario. We posit the gap between the two *can* be incrementally reduced, since it essentially represents pre-processing inefficiency, deferring this to future work.

4 Hardware-based AES

In this section, we shift focus to hardware-based execution of AES using the cryptographic co-processor. As in Section 3, the attacker can still observe the computation of

$$c_i = \text{DUT}_k^{\text{AES-128-CBC}}(m_i) \rightsquigarrow \lambda_i$$

as invoked via OpenSSL. However, the underlying encryption operations are performed using a hardware-based AES implementation. We suggest this is likely to reflect use-cases such as Full Disk Encryption (FDE) given the potential to marshal operations via DMA. In such a use-case, the attacker can access c_i since this will represent (a block of) ciphertext stored on, and readable from, the disk in question.

4.1 Experimental outline

As noted in Section 2.1, there is scant documentation for the AM335x cryptographic co-processor: our only insight into the internal design stems from device drivers that support interaction with it. Since the drivers do not expose any system calls for use by user processes, such interaction is realised concretely by enabling the OpenSSL `cryptodev` extension: each encryption operation invoked is processed, by OpenSSL, via the associated `cryptodev` kernel module and ultimately performed by the co-processor.

Black-box architectural analysis. Treating the co-processor as a black-box, we use the functionality offered (i.e., ECB, CBC and CTR modes, with 128-, 192- and 256-bit key sizes) and the extensive literature on similar hardware designs to infer the (probable) internal design. Specifically, the registers exposed (e.g., for the IV) and requirement to reinitialise the key register per invocation (so the key schedule is likely recomputed for each encryption) suggest an iterative design: a single (combinatorial) core is likely used by surrounding control logic in multiple steps to realise each mode. The default driver behaviour capitalises on hardware DMA support, via the scatter-gather mechanism, to operate autonomously from the ARM core.

Signal hunting. During any exploration phase, it is important to first establish a) an identifiable form and b) a base alignment point for the target signal; doing so maximises the chances of successfully detecting leakage. The two challenges are intrinsically linked, since a well defined form will facilitate alignment. However, the former challenge is perceived as being simple, because the target operation will typically yield a pronounced, identifiable form by virtue of how it is computed and by what. This was true, for instance, in Section 3: we were able to easily detect leakage from the ARM core by monitoring the frequency response during execution. In contrast, this is not true for the co-processor: not only is it unclear how AES is computed, we could not identify any periodic leakage signature linked to the AES operation. This is complicated further by virtue of the fact that the co-processor operates (semi-)independently of the ARM core (thus any hardware trigger used will be asynchronous to encryption operations).

Without any visual cues nor a reliable trigger, we were unsuccessful in detecting leakage under fixed-versus-random tests at the probe locations identified in Section 3. Further attempts to manually scan the AM335x surface at alternative probe locations did not yield better results. However, we *did* manage to detect the DMA strobes by locating a probe over the memory access region: these are, of course, inherently related to encryption operations and hence (to some degree) yield a (somewhat) synchronous trigger for activity by the co-processor. The difficulty with capitalising on this fact is that *any* memory intensive instruction sequence can cause false positives, rendering the trigger less reliable.

To combat this issue, we instead rely on saturating the DMA engine with *other* work: this forces the driver into a non-DMA fall-back mode, which issues interrupts for any memory management. These interrupts are used as a trigger for AES operations on the co-processor. While less ideal than the free-running

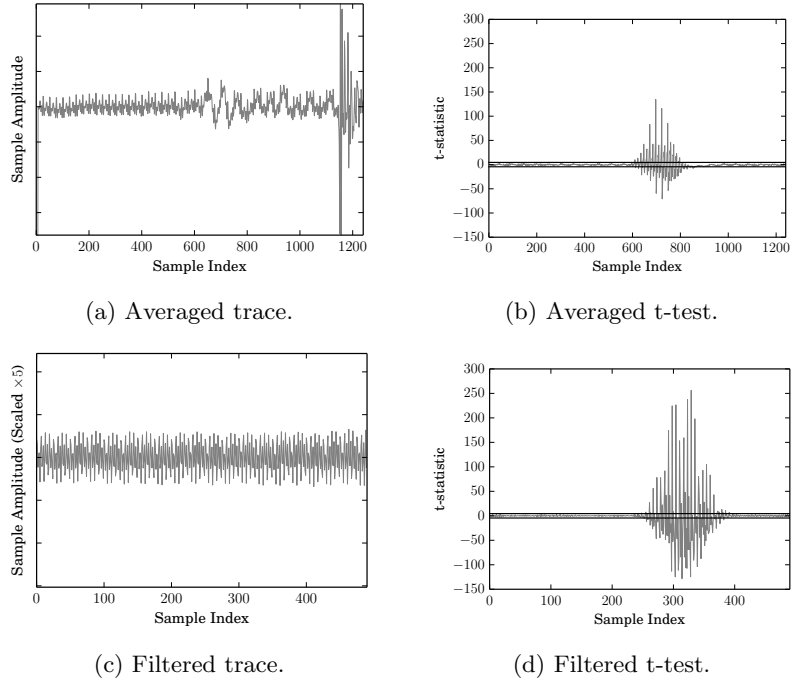

Fig. 6: Leakage detection test results for the AES co-processor running with a saturated DMA. The two columns relate to an averaged trace (left) and the related t-test result (right). The rows are indicative of raw unprocessed traces (top) and traces post-processed via the wavelet analysis (bottom).

scenario in Section 3, we argue this *is* incrementally better than a GPIO-based hardware trigger. Specifically, it requires an attacker controlled process be co-resident on the target device (cf. “spy process” in access-driven cache attacks such as [36]) rather than invasive alteration of the target process.

Testing strategy. With the trigger mechanism active, we placed several probes at various locations on the AM335x surface and repeated the same fixed-versus-random tests as above (using all available channels on the oscilloscope, sampling at a rate of 2.5 GS/s). Their repeated failure led us to abandon generic fixed-versus-random tests, and instead focus on more specifically tailored leakage detection test vectors. A test plan was developed to target several leakage models, using semi-fixed-versus-random [6, Section 5] test vectors. The only strategy to yield detectable leakage (which we focus on subsequently as a result) was Hamming distance; the associated test vectors force a small Hamming distance between round input and output. Figure 6 shows an averaged trace and the resulting t-test result (over 10,000 traces); note that the t-statistic far exceeds our significance threshold of $\tau = 4.5$.

Signal processing and detrending. Although the leakage detection step was successful, it gave us little insight into the signal characteristics. As a first step, we

carried out an automated scan of the AM335x surface, performing semi-fixed-versus-random tests (over 400 traces) at increments of 1 mm in each dimension; the location yielding the highest t-statistic will likely maximise our chances of success during key recovery.

Having optimised the probe location, we applied wavelet analysis [15] in an attempt to increase the SNR. There are already results [10,16] demonstrating wavelet transforms effective for filtering (denoising) and decomposition analysis in the context of side-channel attack. In general, denoising involves applying a soft-threshold [17,18] on the details components at each filter level before resynthesising the (clean) signal. However, a high-magnitude, semi-correlated interference signal overlaid the low-magnitude signal of interest. Both signals separately had low-noise but the interference reduced the SNR of the signal of interest. As the interference contained overlapping frequencies with the signal of interest, a wavelet based detrending scheme, as used in [39], provided an effective and efficient approach for separation. After trying various wavelets, ones with a lower number of vanishing moments provided better results, indicating the need for a fast response to sudden changes in the interference [15,41]. The detrending technique follows a simple algorithm, inspired by the wavelet shrinkage techniques as described in [10,16]. First, perform the DWT [30] with the Haar wavelet. The low ratio of the sampling rate over frequency content of the signal required only a single level computed. Then, set all of the resulting approximation coefficients to zero before performing an inverse DWT on the detail coefficients. The resulting signal (shown in Figure 6) with the interference extracted, yields a stronger result from the leakage detection test.

4.2 Analysis and discussion

Summarising the section above, to mount a concrete attack we performed an acquisition phase as follows:

1. Saturate the DMA mechanism such that the driver operates in the non-DMA fall-back mode.
2. Acquire $n = 500,000$ traces, each associated with 1 encryption operation and averaged over $l = 1,000$ trials; match these traces with the associated ciphertexts.
3. Apply wavelet post-processing to each trace to maximise SNR.

Note that our interrupt-based trigger offers the best alignment achievable; post-processing to improve alignment was impossible, due to the lack of an identifiable form for AES operations. The acquisition process took around 3 days. To exploit the leakage, we then applied a single-bit correlation-based attack: if s_i denotes the AES state after i iterations through the AES core, we target $\mathcal{D}(s_{i-1}, s_i)$ for $i = 10$ relating to the final AES round. This succeeded in recovering k (albeit with a modest amount of key enumeration to cope with one lower-ranked byte).

There are (at least) three important conclusions to draw from the above. First, the effort required to identify leakage from the device far outweighs that of subsequent acquisition and attack phases: only by using a rigorous leakage detection methodology were we able to get a satisfactory outcome. Second, a

gap exists: although Figure 6 indicates that strong leakage *is* identified, our attack is unable to capitalise on this efficiently. This suggests that while leakage detection is a necessary first step, translating it into an accurate leakage model (in our case, Hamming distance seems not to be so) is also important in concrete attack scenarios. Third, while black-box analysis gave some insight into the co-processor architecture, this did not extend to the internal implementation. In particular, the initial failure of our testing strategy suggests either a) the trigger mechanism is not accurate enough to align traces correctly, hence decimating the SNR, and/or b) the co-processor is, in some way, protected against side-channel attacks. *If* the latter is true, it remains unclear *which* countermeasure is implemented: in contrast with Heinz et al. [24], for example, there is no structure in the signal that suggests time-based hiding, but equally attempted higher-order attacks on possible masking strategies were unsuccessful. Either way, *if* a countermeasure is implemented, then we conclude it only seems effective in increasing attack cost rather than preventing an attack.

5 NEON

NEON is a general-purpose SIMD extension to Cortex A-series ARM cores, harnessed, for example, by Bernstein and Schwabe [8] to both accelerate cryptographic workloads and deliver constant execution time. In terms of the ISA, each vector instruction \odot^w processes vector operands with $l = \frac{n}{w}$ elements (or sub-words), each w -bits in size; $n \in \{64, 128\}$ is determined by the instruction type (more specifically, whether the operands are double- or quad-words). For the simplest case of a pure vector operation, we can therefore say

$$\mathbf{r} = \mathbf{x} \odot^w \mathbf{y} \mapsto \langle r^w[0] = x^w[0] \odot^w y^w[0], \dots, r^w[l-1] = x^w[l-1] \odot^w y^w[l-1] \rangle$$

where $t^w[j] = \mathbf{t}[j \cdot w, \dots, (j+1) \cdot w - 1]$ is the j -th w -bit (scalar) sub-word of vector \mathbf{t} , and \odot^w is the operation \odot for such sub-words. The ISA naturally captures standard logical (e.g., $\odot = \oplus$ with $w = 1$) and arithmetic (e.g., $\odot = +$ with $w = 8$, $w = 16$ or $w = 32$) operations, plus various more specialist extensions. Note that although the semantics of quad-word NEON instructions suggest they process 128-bit operands, the pipeline will in fact issue two 64-bit micro-operations.

5.1 Instruction-level characterisation

In this section we study leakage from (a subset of) NEON instructions by focusing on observation of

$$\mathbf{r}_i = \text{DUT}^{\odot^w}(\mathbf{x}_i, \mathbf{y}_i) \rightsquigarrow \lambda_i$$

for a range of \odot^w but, without loss of generality, on $w \in \{8, 32\}$ bit sub-words within double-word, i.e., $n = 64$ bit, operands. Given that the NEON pipeline is tightly coupled to the ARM pipeline, we reason the two will be physically close on the AM335x surface; as such, we retain the same experimental configuration (e.g., same probe location) as Section 3. However, our specific remit means we

compromise by using a strictly controlled profiling device: a hardware trigger is used throughout to support instruction-level (i.e., cycle-accurate) alignment and hence a lower bound on success rate.

Leakage detection. We performed an initial exploration focused on a limited, indicative set of NEON instructions: the aim was to gather general intuition about their leakage characteristics. As such, we considered various potential sources of leakage. Consider, for example, execution of a vector XOR instruction (e.g., `veor.u32 d0, d1, d2`): one could potentially observe leakage related to operand reads (i.e., from `d1` and/or `d2`), computation of the operation, or result write-back (i.e., to `d0`).

In summary, the results show that a) clear operation-dependent SPA leakage is evident, allowing, for example, construction of per-instruction templates, and b) data-dependent leakage is evident, but from result write-back only: we could identify no leakage relating to operand reads. The latter fact, i.e., the statistically observable difference between write-back of random versus fixed results, confirms that the leakage point relates to said step (not reading operands from memory).

Hamming weight leakage. Having identified a set of leakage points, our next goal was to analyse and exploit their structure. More specifically, we attempted to align the characterisation with standard attacks by tracking the Hamming weight of results written-back against associated leakage. This is achieved by amending the fixed-versus-random methodology, so semi-fixed test vectors are selected (for a given Hamming weight).

The results of this analysis, plus their utility, are discussed in the following sections. We stress that, throughout, the Hamming weight of the entire n -bit result is considered: our results show that focusing on an individual w -bit sub-word *is* feasible, but with the expected increase the number of traces. That is, if one considers leakage with regards to a single w -bit sub-word then the other $l - 1$ sub-words can be considered noise (thus overcome by acquiring more traces).

Arithmetic and logical operations. Figure 7 illustrates leakage from two specific NEON instructions pertinent to cryptography. The (vector) XOR case is indicative of most instructions, in the sense that clear separation between distinct Hamming weights is evident. In contrast, the vector polynomial multiplication is something of a special case. The separation between distinct Hamming weights is still evident, and potentially relevant to cryptographic use-cases (e.g., [9]). However, unlike the other instructions there is some “cross over” with regard to the Hamming weight and signal that we cannot currently explain.

Comparison operations. Figure 8 illustrates leakage from a NEON vector comparison instruction. In contrast to a scalar comparison on the ARM core (which produces a 1-bit result in the CPSR status register), a NEON vector comparison sets (or clears) all w bits in each sub-word to signal true or false (i.e., forms a mask). Without loss of generality, we focus on equality comparison:

$$r^w[j] = \begin{cases} 2^w - 1 & \text{if } x^w[j] = y^w[j], \\ 0 & \text{otherwise.} \end{cases}$$

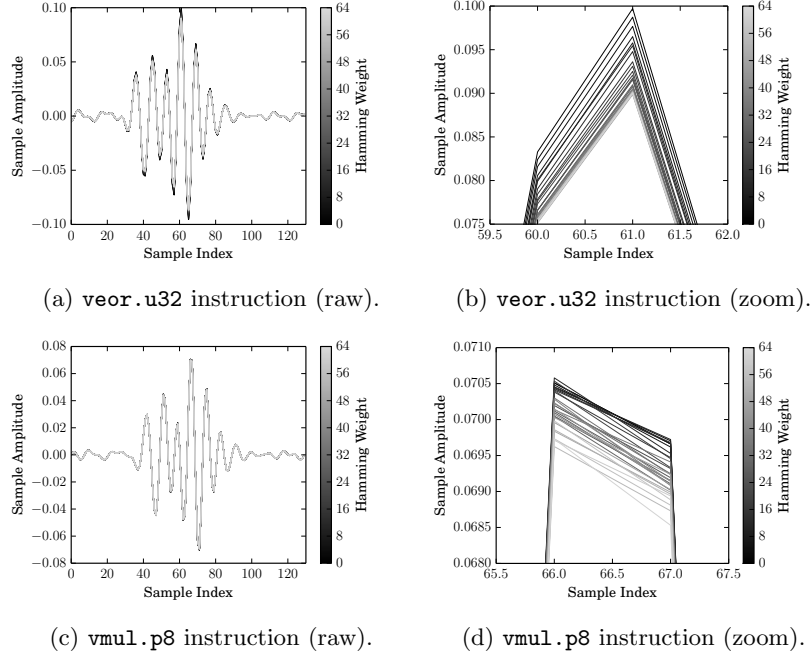

Fig. 7: Illustration of Hamming weight leakage for a (limited) set of NEON arithmetic and logical instructions (where $w = 32$).

This can be used to support branch-free, constant-time implementations: the resulting mask is used to control conditional execution of subsequent operations in each sub-word, replacing conditional *control-flow* by conditional *data-flow*.

Our results demonstrate two important facts. First, analysis of leakage from a vector comparison reveals the (total) number of sub-word results that were true (or false); this is as expected, given the maximal and minimal Hamming weight of the outputs (i.e., masks) produced in each case. Second, as demonstrated by Figure 10, it is possible to target a *specific* sub-word, and hence ascertain whether it has the value $2^w - 1$ or 0. Doing so means considering each sub-word independently, treating the remaining sub-words as noise (cf. single-bit DPA).

5.2 A concrete attack on AES

The characterisation above clearly suggests Hamming weight leakage can be leveraged in concrete attacks. As justification, we consider a scenario where the attacker can observe computation of

$$m_i = \text{DUT}_k^{\text{AES-128-CBC}}(c_i) \rightsquigarrow \lambda_i$$

but alter how AES itself is realised (compared with Section 3 and Section 4): we instead target the NEON-based bit-sliced implementation in OpenSSL (which stems from work by Käsper and Schwabe [26], and was enabled via the pre-processor flag `-DBSAES_ASM`).

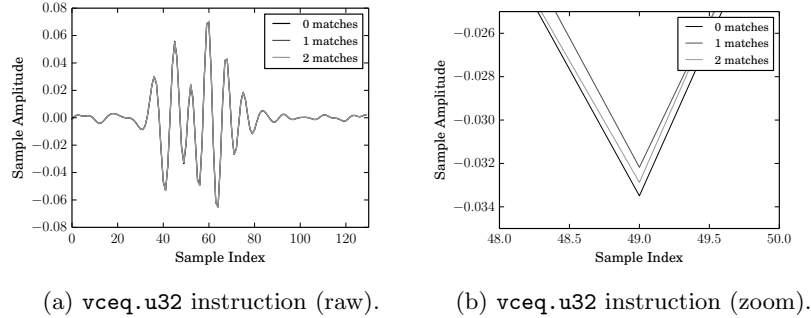

Fig. 8: Illustration of Hamming weight leakage for NEON comparison instructions (where $w = 32$).

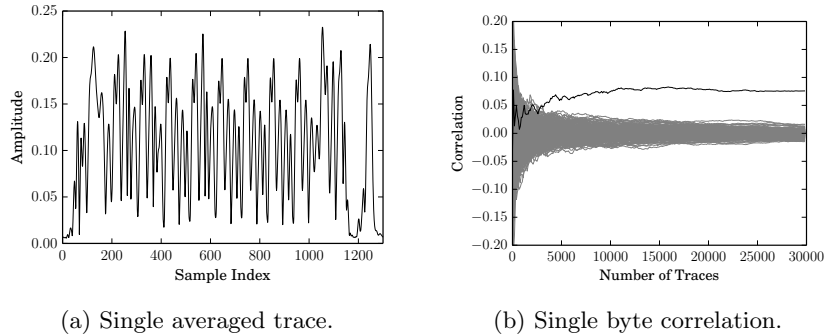

Fig. 9: Illustration of decryption (for a 128-byte ciphertext) using the NEON-based bit-sliced implementation of AES in OpenSSL; the corresponding correlation coefficient evolution suggests the attack succeeds with $\sim 5,000$ traces.

This particular implementation is triggered if c_i is sufficiently large (namely 128 bytes, falling-back to an alternative implementation otherwise). Although we note the techniques in Section 3 remain broadly applicable, for clarity we retain the same experimental environment as Section 5.1 (e.g., with a hardware trigger). The attack then proceeds in a fairly straightforward manner: we simply use key (byte, due to the representation of data used by the implementation) hypotheses based on Hamming weight of the intermediate state after the first round `InvSubBytes` operation in a standard, correlation-based approach. The attack succeeds with $\sim 5,000$ traces, requiring $5000 \cdot 128 = 625$ kB of ciphertext.

5.3 A theoretical attack on NORX

Perhaps more so than other operations, the relevance of leakage from a vector comparison needs motivation. As such, consider NORX [4], an AEAD-based CAESAR candidate whose reference implementation⁸ harnesses NEON. The

⁸ See <http://github.com/norx/NORX>. We stress our analysis should in no way be inferred as criticism of NORX within the context of CAESAR.

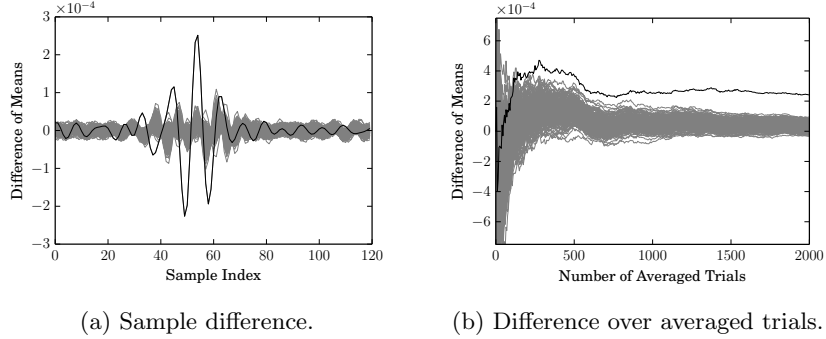

Fig. 10: Illustration of a single-word attack on `vceq.u32`: the black hypothesis for $r^w[j] = 2^w - 1$ (i.e., where the comparison is true, without loss of generality for $j = 0$) is clearly distinguished after averaging over 1,000 trials.

NORX32-6-1 parametrisation (i.e., for 32-bit word size, 6 rounds, parallelism degree 1, and 128-bit tag size) verifies tags as follows

```

/* Verify tag */
A = vceqq_u32(A, LOADU(c + 0));
return 0xFFFFFFFF == (vgetq_lane_u32(A, 0) & vgetq_lane_u32(A, 1) &
    vgetq_lane_u32(A, 2) & vgetq_lane_u32(A, 3)) ? 0 : -1;

```

noting the state `A` (representing the computed tag) is compared with the received tag using vector comparison on 32-bit sub-words.

On one hand this *is* attractive since a) it is likely more efficient than four sequential 32-bit comparisons, and b) it is constant-time, unlike an alternative such as use of `memcmp`. On the other hand, consider a (purely hypothetical) scenario where an attacker has access to a decryption oracle, i.e., execution of

$$\text{DUT}_k^{\text{NORX32-6-1}}(c_i) \rightsquigarrow \lambda_i$$

for chosen c_i can be observed. The resulting leakage can be used to enable tag forgery: the attacker is able to determine the total number of matching sub-words for a candidate tag, so requires $O(2^{32})$ queries (albeit with a constant factor that hides the cost of dealing with noise etc. in acquisitions) to brute-force search for a tag matching ciphertext of their choice. Whether or not such an approach is feasible in practice clearly depends on the context, but equally clear is the gap between this and the supposed (theoretical) security level.

6 Conclusions

In this paper we present concrete, EM-based analysis of the AM335x SoC and software executing on it. Although hard to compare directly, a summary of our results targeting CBC-based AES is shown in Table 1. Beyond this, however, we draw several more general conclusions:

Section	Operation	Implementation	Hardware	Trigger	Acquisitions	Data
3	Decryption	T-tables	ARM core	GPIO-based	3,000	46 kB
3	Encryption	T-tables	ARM core	Network-based	100	400 kB
4	Encryption	Hardware	Co-processor	DMA-based	500,000	7 GB
5	Decryption	Bit-sliced	NEON core	GPIO-based	5,000	625 kB

Table 1: Summary of results.

1. Despite suggestions to the contrary [32], higher clock frequency does not *imply* a requirement for a high sampling rate: instruction- or cycle-level resolution *may* yield better results, but we still observed exploitable leakage at much lower frequencies (mirroring observations such as in [22]). This fact refutes any suggestion that the impact of EM-based attacks (against targets of this complexity) is lessened by cost: for example, in Section 3 a (post-characterisation, i.e., excluding the XY-table) attack can be mounted using \sim \$1,800 of equipment (including a suitable low-end oscilloscope in place of the digitiser, and hand-made 30 AWG coil, 15-turn probe).
2. For devices of this complexity, the value offered by the TVLA methodology is significant: we suggest that an ad hoc analysis would have been difficult or ineffectual, particularly in the context of an unknown target (as in Section 4).
3. Target complexity suggested at a high level does *not* imply the same complexity at lower levels. Our results demonstrate this fact in two examples. First, we were able to bypass complexity relating to the SoC architecture or fabrication technology by targeting support circuitry in Section 3. Second, in Section 5, we observed that parallelism suggested in the NEON ISA (traditionally viewed as a complicating factor in DPA, for example) is not realised in the micro-architecture: This is of relevance to constructions (e.g., [33], albeit studied in the context of hardware) that *rely* on parallelism somehow.
4. Although the drive for efficient, constant-time implementation using NEON is clearly important, it seems prudent to proactively consider when/how such an approach can enable other forms of leakage. For example, Section 5 demonstrates that vector comparison, while advantageous in the sense of having a fixed latency, will still leak information about sub-word (in)equality.
5. Software such as OpenSSL is now becoming commonplace in (embedded) scenarios in which it might traditionally have been deemed too heavy-weight. As a result, alongside the challenging goal of securing such software against network-based attacks, it is starting to seem of long-term importance that countermeasures for hardware side-channels are also proactively considered.

Acknowledgements

Jake Longo has been supported in part by a studentship under the EPSRC Doctoral Training Partnership (DTP) scheme. The authors would like to thank Pankaj Rohatgi for general discussion, and Sami Saab for specific help with signal processing/analysis. We also thank both Billy Brumley and Markku Saarinen for their insight on NEON-based implementation, Martijn Stam for discussion about AEAD, and the NORX team, all of who help improved Section 5.

References

1. D. Aboukassimi, M. Agoyan, L. Freund, J.J.A. Fournier, B. Robisson, and A. Tria. ElectroMagnetic Analysis (EMA) of software AES on Java mobile phones. In *Information Forensics and Security (WIFS)*, pages 1–6, 2011.
2. D. Aboukassimi, J.J.A. Fournier, L. Freund, B. Robisson, and A. Tria. EMA as a physical method for extracting secret data from mobile phones. *IJCSA*, 2(1):16–25, 2013.
3. D. Agrawal, B. Archambeault, J.R. Rao, and P. Rohatgi. The EM side-channel(s). In *CHES*, pages 29–45. LNCS 2523, 2003.
4. J.-P. Aumasson, P. Jovanovic, and S. Neves. NORX. CAESAR submission specification, version 1.1, 2014. <http://norx.io/data/norx.pdf>.
5. J. Balasch, B. Gierlichs, R. Verdult, L. Batina, and I. Verbauwhede. Power analysis of Atmel CryptoMemory – recovering secret keys from secure EEPROMS. In *CT-RSA*, pages 19–34. LNCS 7178, 2012.
6. G.T. Becker, J. Cooper, E. DeMulder, G. Goodwill, J. Jaffe, G. Kenworthy, T. Kouzminov, A. Leiserson, M. Marson, P. Rohatgi, and S. Saab. Test Vector Leakage Assessment (TVLA) methodology in practice. In *ICMC*, 2013.
7. G.T. Becker, M. Kasper, A. Moradi, and C. Paar. Side-channel based watermarks for IP protection. In *COSADE*, pages 47–50, 2010.
8. D.J. Bernstein and P. Schwabe. NEON crypto. In *CHES*, pages 320–339. LNCS 7428, 2012.
9. D. Câmara, C.P.L. Gouvêa, J. López, and R. Dahab. Fast software polynomial multiplication on ARM processors using the NEON engine. In *CD-ARES*, pages 137–154. LNCS 8128, 2013.
10. X. Charvet and H. Pelletier. Improving the DPA attack using wavelet transform. In *NIST Physical Security Testing Workshop*, 2005.
11. T. Chothia and A. Guha. A statistical test for information leaks using continuous mutual information. In *CSF*, pages 177–190, 2011.
12. O. Choudary and M.G. Kuhn. Efficient template attacks. In *CARDIS*, pages 253–270, 2013.
13. O. Choudary and M.G. Kuhn. Template attacks on different devices. In *COSADE*, pages 179–198, 2014.
14. J. Daemen and V. Rijmen. *The Design of Rijndael*. Springer, 2002.
15. I. Daubechies. *Ten Lectures on Wavelets*. CBMS-NSF Regional Conference Series in Applied Mathematics. Society for Industrial and Applied Mathematics, 1992.
16. N. Debande, Y. Souissi, M.A.E. Aabid, S. Guilley, and J. Danger. Wavelet transform based pre-processing for side channel analysis. In *MICROW*, pages 32–38, 2012.
17. D.L. Donoho. De-noising by soft-thresholding. *IEEE Transactions on Information Theory*, 41(3):613–627, 1995.
18. D.L. Donoho and I.M. Johnstone. Ideal spatial adaptation by wavelet shrinkage. *Biometrika*, 81(3):425–455, 1994.
19. D. Du, S. Narasimhan, R. Subhra Chakraborty, and S. Bhunia. Self-referencing: A scalable side-channel approach for hardware Trojan detection. In *CHES*, pages 173–187. LNCS 6225, 2010.
20. T. Eisenbarth, T. Kasper, A. Moradi, C. Paar, M. Salmasizadeh, and M.T. Manzuri Shalmani. On the power of power analysis in the real world: A complete break of the KeeLoq code hopping scheme. In *CRYPTO*, pages 203–220. LNCS 5157, 2008.
21. K. Gandolfi, C. Mourtel, and F. Olivier. Electromagnetic analysis: Concrete results. In *CHES*, pages 251–261. LNCS 2162, 2001.

22. D. Genkin, L. Pachmanov, I. Pipman, and E. Tromer. Stealing keys from PCs by radio: Cheap electromagnetic attacks on windowed exponentiation. Cryptology ePrint Archive, Report 2015/170, 2015. <http://eprint.iacr.org/>.
23. G. Goodwill, B. Jun, J. Jaffe, and P. Rohatgi. A testing methodology for side-channel resistance validation. In *NIST Non-Invasive Attack Testing Workshop*, 2011.
24. B. Heinz, J. Heyszl, and F. Stumpf. Side-channel analysis of a high-throughput AES peripheral with countermeasures. In *ISIC*, pages 25–29, 2014.
25. Texas Instruments. AM335x Sitara processor datasheet. Technical Report SPRS717G, TI, 2014. <http://www.ti.com/lit/ds/symlink/am3358.pdf>.
26. E. Käsper and P. Schwabe. Faster and timing-attack resistant AES-GCM. In *CHES*, pages 1–17. LNCS 5747, 2009.
27. M. Kasper, T. Kasper, A. Moradi, and C. Paar. Breaking KeeLoq in a flash: On extracting keys at lightning speed. In *AFRICACRYPT*, pages 403–420. LNCS 5580, 2009.
28. P.C. Kocher, J. Jaffe, and B. Jun. Differential power analysis. In *CRYPTO*, pages 388–397. LNCS 1666, 1999.
29. J. Longo, E. De Mulder, D. Page, and M. Tunstall. SoC it to EM: electromagnetic side-channel attacks on a complex system-on-chip. Cryptology ePrint Archive, 2015. <http://eprint.iacr.org/>.
30. S.G. Mallat. A theory for multiresolution signal decomposition : the wavelet representation. *IEEE Transactions on Pattern Analysis and Machine Intelligence*, 11(7):674–693, 1989.
31. S. Mangard, E. Oswald, and T. Popp. *Power analysis attacks: Revealing the secrets of smart cards*. Springer, 2008.
32. E. Mateos and C.H. Gebotys. Side channel analysis using Giant Magneto-Resistive (GMR) sensors. In *COSADE*, pages 42–49, 2011.
33. M. Medwed, F.-X. Standaert, and A. Joux. Towards super-exponential side-channel security with efficient leakage-resilient PRFs. In *CHES*, pages 193–212. LNCS 7428, 2012.
34. A. Moradi, A. Barenghi, T. Kasper, and C. Paar. On the vulnerability of FPGA bitstream encryption against power analysis attacks: extracting keys from Xilinx Virtex-II FPGAs. In *CCS*, pages 111–124, 2011.
35. A. Pellegrini, V. Bertacco, and T. Austin. Fault-based attack of RSA authentication. In *DATE*, pages 855–860, 2010.
36. C. Percival. Cache missing for fun and profit, 2005. <http://www.daemonology.net/papers/htt.pdf>.
37. J.-J. Quisquater and D. Samyde. ElectroMagnetic Analysis (EMA): Measures and counter-measures for smart cards. In *E-SMART*, pages 200–210. LNCS 2140, 2001.
38. P. Rohatgi. Electromagnetic attacks and countermeasures. In *Cryptographic Engineering*, pages 407–430. Springer, 2009.
39. S. Saab, A. Leiserson, and M. Tunstall. Efficient key extraction from the primary side of a switched-mode power supply. Cryptology ePrint Archive, Report 2015/512, 2015. <http://eprint.iacr.org/>.
40. J. Scahill and J. Begley. iSpy: The CIA campaign to steal Apple’s secrets. The Intercept, 2015. <http://firstlook.org/theintercept/2015/03/10/ispy-cia-campaign-steal-apples-secrets/>.
41. G. Strang and G.J. Fix. *An Analysis of the Finite Element Method*. Automatic Computation. Prentice-Hall, 1973.
42. H. Uno, S. Endo, Y. Hayashi, N. Homma, and T. Aoki. Chosen-message electromagnetic analysis against cryptographic software on embedded OS. In *EMC*, 2014.

43. A. Zajic and M. Prvulovic. Experimental demonstration of electromagnetic information leakage from modern processor-memory systems. *IEEE Transactions on Electromagnetic Compatibility*, 56(4):885–893, 2014.