

6-8-2015

# Might-E Wheel

Abigail Grills  
*Santa Clara University*

Daniel Doke  
*Santa Clara University*

Jared O'Rourke  
*Santa Clara University*

Zach Jesberger  
*Santa Clara University*

Follow this and additional works at: [http://scholarcommons.scu.edu/idp\\_senior](http://scholarcommons.scu.edu/idp_senior)

 Part of the [Electrical and Computer Engineering Commons](#), and the [Mechanical Engineering Commons](#)

---

## Recommended Citation

Grills, Abigail; Doke, Daniel; O'Rourke, Jared; and Jesberger, Zach, "Might-E Wheel" (2015). *Interdisciplinary Design Senior Theses*. Paper 11.

This Thesis is brought to you for free and open access by the Engineering Senior Theses at Scholar Commons. It has been accepted for inclusion in Interdisciplinary Design Senior Theses by an authorized administrator of Scholar Commons. For more information, please contact [rscroggin@scu.edu](mailto:rscroggin@scu.edu).

**SANTA CLARA UNIVERSITY**

Department of Mechanical Engineering  
&  
Department of Electrical Engineering

I HEREBY RECOMMEND THAT THE THESIS PREPARED  
UNDER MY SUPERVISION BY

Abigail Grills, Daniel Doke, Jared O'Rourke, and Zach Jesberger

ENTITLED

**MIGHT-E WHEEL**

BE ACCEPTED IN PARTIAL FULFILLMENT OF THE REQUIREMENTS  
FOR THE DEGREE OF


**BACHELOR OF SCIENCE IN MECHANICAL ENGINEERING  
&  
BACHELOR OF SCIENCE IN ELECTRICAL ENGINEERING**



ME Thesis Advisor

6/10/15

date



EE Thesis Advisor

6/10/15

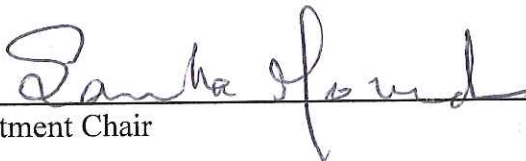
date



ME Department Chair

6/10/15

date



EE Department Chair

6/10/15

date

# MIGHT-E WHEEL

By

Abigail Grills, Daniel Doke, Jared O'Rourke,  
and Zach Jesberger

## SENIOR DESIGN PROJECT REPORT

Submitted to  
The Departments of Mechanical & Electrical Engineering

of

SANTA CLARA UNIVERSITY

in Partial Fulfillment of the Requirements  
for the Degrees of  
Bachelor of Science in Mechanical & Electrical Engineering

Santa Clara, California

June 8, 2015

# **Might-E Wheel**

Abigail Grills, Daniel Doke, Jared O'Rourke,  
and Zach Jesberger

Departments of Mechanical & Electrical Engineering  
Santa Clara University  
2015

## **ABSTRACT**

Electric bikes are proving to be an increasingly reliable source of transportation, but with large price tags and existing conversion kits proving too complicated and unapproachable for the average user, commuters are failing to consider electric bicycles as an option. A prototype of a wireless, rear-wheel replacement to convert a bicycle from manual to full-power electric was built. This motorized wheel is called Might-E Wheel. Might-E Wheel was designed as the most approachable and user-friendly way to convert a bicycle from manual to full-power electric. Might-E Wheel was able to achieve a top speed of 27.5 km/h, a range of 24.6 km, and run at 311 W of power. Range tests were inconclusive. The fully assembled system weighed 6.8 kg. The system was found to adequately meet the goals of the project. Battery failure limited the testing of Might-E Wheel, but the system was found to run smoothly before the failure, which was unrelated to the system design. In the future, further tests are planned with new batteries. Also, further development of the product is desired in order to lower the weight and reduce the size of the system. Ideally, the next prototype of the system would consist of a custom built motor and a fully-enclosed system within the hub of the wheel.

**Keywords:** Electric Bicycles, Transportation, Green Technologies

## **Acknowledgements**

Many individuals and groups deserve acknowledgement for assistance in this project. The Santa Clara University Undergraduate Senior Design Grant and the Center for Science, Technology, and Society's Roelandts Grant funded the project. Dr. Robert Marks and Dr. Timothy Healy, the project advisors, assisted the entire project from conception to construction to the writing of the thesis. Dr. Jacquelyn Hendricks, the project's English professor, assisted heavily with the initial research and formatting of the thesis.

Other professors that assisted in the engineering of the project include Dr. Timothy Hight, Dr. Scott Abrahamson, and Dr. Christopher Kitts. Don Maccubbin and Calvin Sellers, the Santa Clara University machine shop managers, assisted heavily in the construction of the project. External names and organizations that deserve acknowledgement include Good Karma Bikes, ELV Motors, Arman Toorian, and Chris Yu of Specialized Bikes. Thank you to all the people listed here; this project could not have been completed without them.

## TABLE of CONTENTS

Abstract.....	i
Acknowledgements.....	ii
Chapter 1 – Introduction.....	1
1.1 Problem Statement.....	1
1.2 Project Objectives.....	1
1.3 Project Background and Motivation.....	2
Chapter 2 - Project Overview.....	4
2.1 Customer Needs.....	4
2.2 System Requirements.....	7
2.2.1 Customer Requirements.....	8
2.2.2. Engineering Requirements.....	8
2.3 Functional Analysis.....	9
2.4 Benchmarking Results.....	10
2.5 System Level Issues, Options, Tradeoffs, and Rationales.....	11
2.6 Systems-Level Overview.....	13
2.7 Subsystem Breakdown.....	13
2.7.1 Wheel Assembly.....	14
2.7.2 Handlebar Assembly.....	14
2.8 Team and Project Management.....	14
2.8.1 Challenges & Constraints.....	14
2.8.2 Budget.....	14
2.8.3 Timeline.....	15
2.8.4 Risks and Mitigations.....	15
2.8.5 Team Management.....	16
Chapter 3 - Subsystem Descriptions.....	16
3.1 Rear Wheel Assembly.....	16
3.1.1 Motor.....	19
3.1.2 Vertical Supports.....	20
3.1.3 Top Structure.....	21
3.1.4 Separation Rods.....	21
3.1.5 Seat Stay Clamps.....	22
3.1.6 Batteries.....	22

3.1.7 Battery Support Steps.....	23
3.1.8 Battery Straps.....	23
3.1.9 Composite Case.....	24
3.2 Handlebar Interface.....	24
3.2.1 Throttle.....	24
3.2.2 Regenerative Brake.....	25
3.2.3 Connectivity.....	26
3.3 Design Process.....	28
Chapter 4 - Systems Integration & Testing.....	30
4.1 Top Speed .....	30
4.2 Range Test.....	31
4.3 Weight Test.....	34
4.4 Installation Time Test.....	34
Chapter 5 - Engineering Standards & Realistic Constraints.....	34
5.1 Health & Safety Impacts.....	34
5.2 Social Impacts.....	35
5.3 Economic Impacts.....	36
5.4 Environmental Impacts.....	37
5.5 Manufacturability.....	37
5.6 Realistic Constraints.....	38
5.6.1 State Laws.....	38
5.6.2 Size.....	38
5.6.3 Weight.....	39
5.6.4 Range.....	39
5.6.5 Cost.....	39
Chapter 6 - Summary & Conclusion.....	39
6.1 Summary.....	39
6.2 Future Work.....	40
Appendix A: Budget.....	44
Appendix B: Gantt Chart.....	45
Appendix C: Safety Risks and Mitigations.....	46
Appendix D: Electrical Calculations.....	48
Appendix E: Inertia Calculations.....	52

Appendix F: Finite Element Analysis.....	53
Appendix G: Wind Speed to Pressure Conversion Chart.....	58
Appendix H: Business Plan.....	59
Appendix I: Artistic Contributions.....	65
Appendix J: Mechanical Drawings.....	66



## LIST of FIGURES

Figure 1-1: FlyKly Design.....	3
Figure 1-2: FlyKly Product Deliverable.....	3
Figure 1-3: Copenhagen Wheel Design.....	4
Figure 1-4: Copenhagen Wheel Product Deliverable.....	4
Figure 2-1: System & Subsystems Functional Decomposition.....	10
Figure 2-2: Layout of System-Level Design with Main Subsystems.....	13
Figure 3-1: The Might-E Wheel Installed.....	17
Figure 3-2: Exploded View of Might-E Wheel.....	18
Figure 3-3: Smart Pie Hub Motor.....	20
Figure 3-4: Thumb Throttle on Handlebar.....	25
Figure 3-5: Regenerative Braking Lever with Labels.....	26
Figure 3-6: XBee Pin Designation.....	27
Figure 3-7: XBee Experiment.....	28
Figure 3-8: Theoretical Custom Motor Design Cross Section.....	29
Figure 4-1: Nominal Battery System Voltage with Respect to Distance.....	32
Figure 4-2: Individual Battery Voltage with Respect to Distance.....	33
Figure 5-1: Percent Income as a Function of Commuting Distance.....	36
Figure A-1: Project Budget.....	44
Figure B-1: Detailed Project Timeline.....	45
Figure E-1: Inertia Calculations.....	52
Figure F-1: FEA of 80 km/h Crosswind (Stresses).....	54
Figure F-2: FEA of 80 km/h Crosswind (Deflection).....	55
Figure F-3: FEA from 270 N Point Force (Deflection).....	56
Figure F-4: FEA from 270 N Point Force with Clamps (Stresses).....	57
Figure H-1: First Year Cash Flow Analysis.....	64
Figure J-1: Exploded Assembly Drawing.....	66
Figure J-2: Full Assembly.....	67
Figure J-3: Battery Support Drawing.....	68
Figure J-4: Top Structure Drawing.....	69
Figure J-5: Battery Structure Drawing.....	70
Figure J-6: Seat Stay Clamp Drawing.....	71

## LIST of TABLES

Table 2-1: Customer Needs Related to Cost.....	5
Table 2-2: Customer Needs Related to Performance.....	6
Table 2-3: Customer Needs Related to Experience.....	7
Table 2-4: Customer Needs Related to Aesthetics.....	7
Table 2-5: FlyKly and Copenhagen Wheel Specifications.....	11
Table 3-1: Part Identification of System Diagram.....	19
Table 4-1: Test Specifications and Results.....	30
Table G-1: Wind Speed to Pressure Conversion Chart.....	58
Table H-1: Might-E Wheel Specifications Compared to Competitors.....	61
Table I-1: The Artistic Contributions Made by Each Team Member.....	65

# **1. INTRODUCTION**

## **1.1 Problem Statement**

Electric bikes are proving to be an increasingly reliable source of transportation, but with large price tags and existing conversion kits proving too complicated and unapproachable for the average user, commuters are failing to consider electric bicycles as an option. Might-E Wheel seeks to provide the most intuitive and user-friendly bicycle conversion kit with its easy-to-install design.

## **1.2 Project Objectives**

The Might-E Wheel is an innovation for the urban commuter, the recreational user, and anyone who wishes to make his travel more sustainable. The wheel provides an alternative to conventional, inefficient modes of transportation and reduces the carbon footprint of the everyday commuter. Our design will convert an existing bicycle into an electric bike controlled by a thumb throttle. The conversion is easily done by installing the Might-E Wheel to the rear of the bicycle and mounting the included handlebar assembly, which includes a remote controlled throttle and a regenerative braking lever. The motor, batteries, and additional electrical components will be stored within the wheel assembly. Making the motor, batteries, and controls a single assembly will make the design more approachable for average users to convert his or her bike. The ease of installation will allow for both novice and expert users to embrace our innovation in alternative transportation technology. The wheel is different and innovative because it allows the freedom of selecting assistive pedaling or full-power electric, while containing all of the necessary components enclosed and protected safely within the wheel or surrounding structure. The rider's experience is enhanced by the ability to choose if he or she wants to coast freely on full electric power or pedal it his/herself, like a traditional bike. The electric capabilities of this bicycle wheel enhances the riding experience by allowing riders to throttle through difficult parts of their ride, making a commute by bicycle more appealing and accessible.

The project utilizes an approach of “upcycling” with regard to innovation. Instead of creating an entirely new bicycle with the intent of replacing the former product, we have

designed a product that enhances the user's current product while minimizing waste and cost. Our easily installable upgrade cuts down on emissions today while addressing the problem of future waste management. We believe this simple, relatively inexpensive product will help take cars off the road and improve riders' quality of life by allowing them to spend more time outdoors and less time in traffic.

### **1.3 Project Background and Motivation**

Commutes in the San Francisco Bay Area are known to be some of the worst in the country with regards to traffic and pollution. The problem can be analyzed both on individual and collective levels. In a study published by the San Francisco Chronicle, it was estimated that the average commuter wastes 25 gallons of excess fuel per year due to congestion and has a "yearly congestion cost" of \$1,266 [1] in addition to regular travel/commuting costs. If our product is sold at the target price (\$1,100), then savings during high-traffic periods alone over a few years may be enough to convince commuters to convert.

Looking at Bay Area traffic on a larger scale adds scope and motivation to our project. The same study stated that Bay Area commuters as a whole spend 155 million hours in traffic and "excess fuel consumption and truck delays" cost an overall \$3.3 billion annually [1]. The hope is that many individuals would use our product to not only reduce these numbers, but also to have an impact on the pollution from the excess traffic that affects both the environment and residents living in metropolitan areas. Our success would result in fewer vehicles on the road, leading to less pollution and a drop in wasted time in traffic. More on the environmental, social, health, and economic impacts of automobiles and bicycles can be found in Chapter 5.

Electric bicycles also serve as a recreational product. Tim Neville wrote in *The New York Times* about his journey over the Alps on an electric bicycle, and the many others he met on his trip also travelling by electric bicycle [2]. Neville, like many other cyclists, enjoys riding to explore new scenic areas. He explains that electric bikes have extended the possibility of traveling long distances on a bike to people who may not have the endurance or physical

capability. This is particularly useful to older cyclists who begin to experience pain due to Arthritis and other factors related to age.

Existing electric bicycles and conversion kits are unappealing to consumers in a number of ways. Electric bicycles are expensive, with low-end models costing around \$1,500 to \$3,000 and prices exceeding \$10,000 for the luxury models. Current conversion kits are complicated, cluttered, and unappealing to the novice user. At a minimum these kits require the user to install the new wheel, batteries and some mounting system, handlebar controls. The wiring runs along the length of the bike from the handlebars to the wheel, making the bike appear cluttered. Many of the current electric bike conversion kits also require the user to program the control system. These systems are complicated and many come without adequate documentation on how to install.

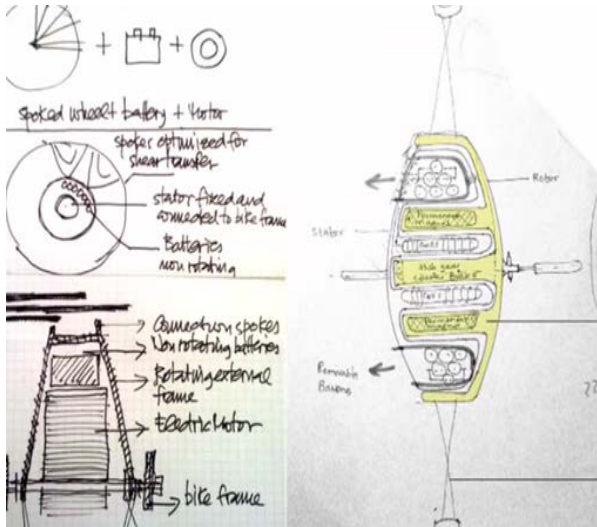
Currently, only two other in-wheel conversion kits exist: FlyKly Smart Wheel (Figures 1-1 & 1-2) and the Copenhagen Wheel (Figures 1-3 & 1-4). Note that all figures taken from external sources were reproduced with permission of their copyright holders.



**Figure 1-1:** FlyKly Design [3]



**Figure 1-2:** FlyKly Product Deliverable [3]



**Figure 1-3: Copenhagen Wheel Design [4]**



**Figure 1-4: Copenhagen Wheel Product Deliverable [4]**

Both of these products house a motor, batteries, and controller within the hub of a bicycle wheel, and the controls are accessed through an iPhone app. Their motors are 250 W and 350 W, respectively, and both operate solely on assisted pedaling - they do not operate without some physical input from the rider (i.e., they are not full-power electric) [3, 4].

Might-E Wheel aims to improve upon these designs by offering fully electric capabilities to a compact, wireless, and easy to install rear-wheel replacement.

## 2. PROJECT OVERVIEW

Chapter 2 provides introductions to and descriptions of the systems functions and requirements, customer needs, user interactions, project results, team and project management.

### 2.1 Customer Needs

A customer needs analysis was performed by interviewing four possible customers: an avid e-biker, an employee of an electric bike store, and two college students who would consider an e-bike for a mode of transportation after they graduate. The main goal of the interviews

was to find the motivation for purchase and use of e-bikes and to form needs/requirements from the observations.

The reasons for purchasing an e-bike varied and applied to a wide demographic. The store employee provided the majority of the customer information, although the avid e-biker shed light on some valuable personal experience. It was found that people are willing to commute farther by e-bike than by standard bike due to less stress on the user; therefore, people in metropolitan areas are likely customers. Some purchased e-bikes for commutes, while others purchased for adventure. The e-bikes make climbing hills and mountains easier, which makes lengthy trips a more viable option. Others cannot drive due to complications in their lives (such as DUI's or losing their driver's license). It was found that people who cannot have a driver's license are not interested in the exercise that traditional bikes offer.

Therefore, they are willing to use e-bikes because they are not strenuous and do not require a license. The final (and biggest) motivation was found to be enjoyment. The fun had while riding an e-bike is a unique and joyful experience, according to the avid e-biker. This aspect opens up a large market for those who want to use e-bikes as a recreational tool.

Next, customer needs/requirements were formed from the observations in the interviews. It was decided to divide the needs into four categories: cost, performance, experience, and aesthetics. Each one contributes to the overall appeal of the product, but they were analyzed separately in order to isolate and concentrate on each specific area of the design. An observation → problem → need approach was then taken to identify what the customer needs from the product; this approach involves stating an observation from the interviews/experiences, identifying a problem from the observation, and deriving a need from the problem.

**Table 2-1:** Customer Needs Related to Cost

Observation	Problem	Need
E-bikes are fairly expensive: generally range \$1,000-\$3,000.	People want to pay a reasonable price to enhance or replace their current form of transportation.	Price must be low enough to be a better option than a full e-bike.

The cost category is straightforward, yet remains the most important constraint for the product. Participants said they would be interested in a conversion for their existing bike, but cost would be an important factor in purchasing. If the product is effective, but costs the same as a full e-bike, then participants said they would rather buy the e-bike in full. Therefore, the product cost must be low enough so that it draws customers away from the fully assembled vehicles.

**Table 2-2:** Customer Needs Related to Performance

<b>Observation</b>	<b>Problem</b>	<b>Need</b>
Bikers do not look happy when they climb up difficult terrain. Arthritis and other issues limit the biking abilities of some users.	Users cannot travel as far as they would like to by bicycle.	Extend the biker's range, enhance the biking experience, and decrease the work a user puts in.
Users want to go on extended trips across the state or country.	Long-range capabilities are difficult to apply to e-bikes.	Provide extra battery and cruise control capabilities.
People do not want to commute by bike if they travel over 16 kilometers.	Bike range is limited when using a manual-powered bike.	An option to extend a bike's range beyond 16 kilometers.

Although cost is seen as the primary constraint, performance comes in at a close second. If the product does not work or does not benefit people, then they have no reason to purchase it. Therefore, needs were formed to match the optimal range that the average user could travel on a charge. Additional performance requirements of extra battery and cruise control capabilities stemmed from the experience of the 60-year-old participant. He believed extra batteries to be a necessity in order to take longer trips and cruise control to be a positive feature that would make longer rides enjoyable.



**Table 2-3:** Customer Needs Related to Experience

<b>Observation</b>	<b>Problem</b>	<b>Need</b>
Commuters <i>via</i> car in traffic are long, stressful and unreliable; commutes via e-bike are consistent and efficient.	Commuters do not enjoy their current transportation experience.	An efficient, enjoyable, and reliable transportation experience.
Very difficult to replace or fix flat tires with a hub motor	Wires connecting to the motor get in the way of removing the wheel for service	An easy way to isolate the hub motor from the wires and be able to completely remove the wheel and motor from the frame

In addition to cost and performance, the customer experience is a large concern of the product. It was noted that certain people are unhappy with the experience provided by their current form of transportation. Therefore, the need for an easy, safe, and fun riding experience is born. Another concern raised is the difficulty of changing flat rear tires with a hub motor attached, as the wiring can be messy. This was kept in mind throughout the development of the product in order to make the user experience as easy and intuitive as possible, especially considering our goal for simple installation.

**Table 2-4:** Customer Needs Related to Aesthetics

<b>Observation</b>	<b>Problem</b>	<b>Need</b>
People enjoy forms of transportation that are aesthetically pleasing.	Conversion kits are difficult to make look sleek and integrated.	System to look simple, sleek and visually pleasing.

Finally, aesthetics was recognized as an important need for the product, though the other needs are more important in the end. A product can function perfectly, but interest may be lost if it looks bland or ugly. So, a need was created to design the product to be as visually enticing as possible while maintaining a simple and user-friendly feel.

## 2.2 System Requirements

This section presents a hypothetical scenario for the standard user that is targeted by Might-E Wheel as well as an explanation of engineering specifications that guided our design.

### **2.2.1 Customer Requirements**

In order to create a useful product that would ultimately benefit the end consumer, a use case analysis was performed from which system requirements were derived. A man lives in a metropolitan area 24 km away from where he works and drives a full size pickup truck. He is frustrated with how difficult it is to find parking, the congested traffic into the city, and the money it takes to fuel and maintain his truck. He is looking for an affordable solution for his daily problem and finds the Might-E Wheel. He has a bicycle that has been stored in his garage for two years and sees the opportunity to solve all of his daily commuting problems. Spending 30 minutes, he installs the Might-E wheel to his existing bike with the quick-disconnect axle and connects the wireless handlebar controls to his right handle to transform his unused bicycle into a vehicle for commuting. Every night he makes sure to charge his phone and Might-E Wheel battery which will power him to work the next morning. His leisurely ride to work every morning includes the fresh air, a stress free ride around traffic, and no more stops at the gas station. Once at work, he pulls his bike up to the front entrance of his office, locks up his bicycle, and charges his batteries while he is at work. Upon his departure, he comfortably commutes home; all the while he was avoiding the terrible parking in the city, flying past congested traffic, and saving money by avoiding the gas station.

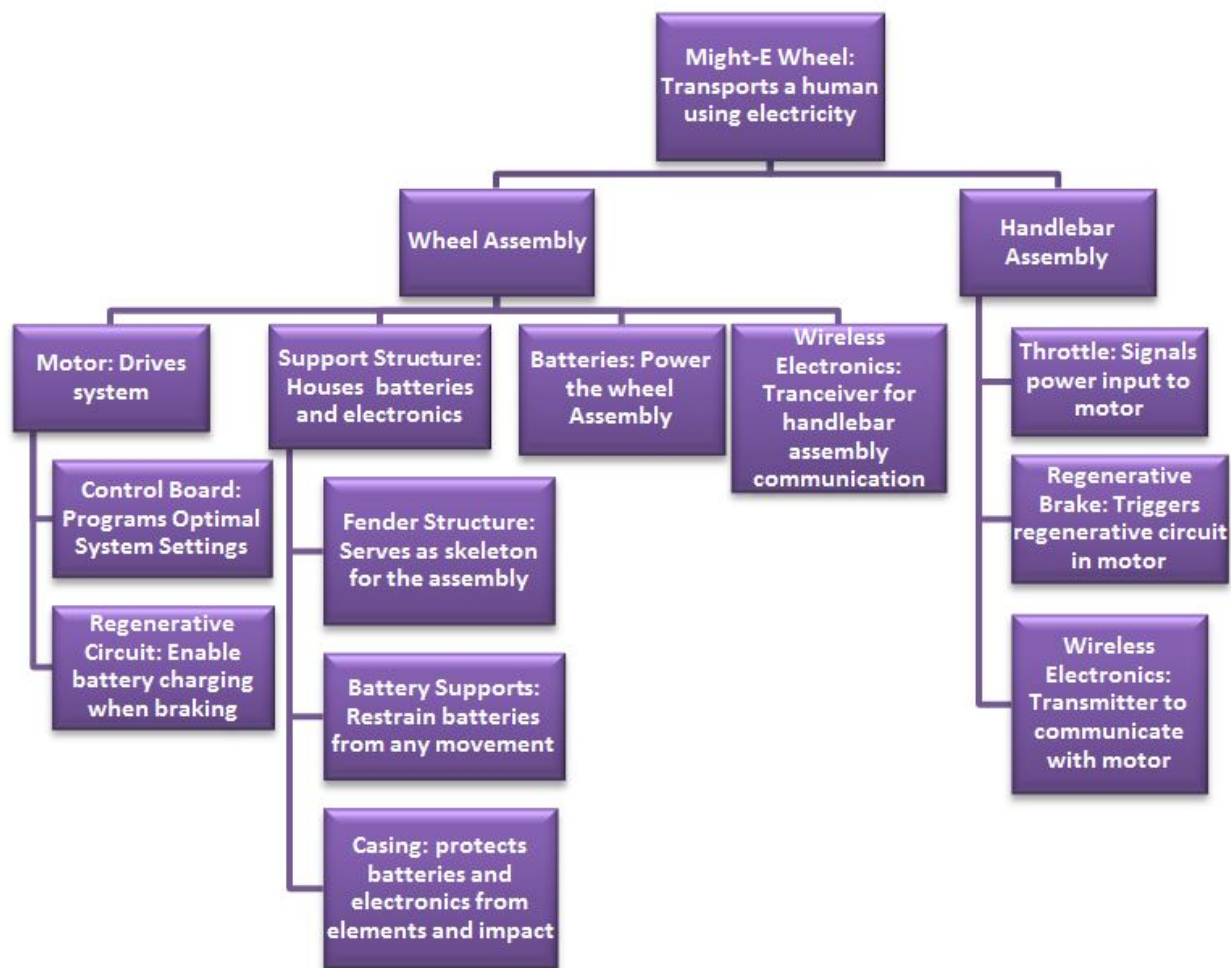
### **2.2.2 Engineering Requirements**

The specifications were designed around assumptions with regards to our users and their needs based on a series of customer interviews. It was determined that the rider to be used for this analysis would be 200 pounds and own a 35 pound bicycle (total weight with Might-E Wheel installed). Calculations were then performed in order to analyze the energy required to power the person and their bicycle, which are explored in further detail in Appendix D. The initial design specification targets were a 32 km range at a top speed of 32 or 40 km/h, 10 starts and stops, and a net elevation change of 500 meters. These constraints were applied to calculate the potential energy, kinetic energy, and total power required to operate the system. After calculating the total amount of stored power needed, the duration for which different powered motors, either 750 watts or 500 watts, could power the system was calculated.

Additional features included in the original design specifications, such as assisted pedaling and regenerative braking, were also explored through calculations to determine exactly how beneficial each additional feature would be, these calculations can also be found in Appendix D. The extended range of assisted pedaling was calculated by determining the power a human could generate and summing it to the power already being supplied to the system. The utility of regenerative braking at different speeds was also analyzed in order to determine its efficacy. Though some of the specifications were later changed or adapted as the project progressed, these initial calculations played an integral role in how the project was understood and the designs that followed.

### **2.3 Functional Analysis**

The ultimate purpose of the Might-E Wheel is to transport someone economically and efficiently. Figure 2-1 shows The breakdown and function of each subsystem in the Might-Wheel.



**Figure 2-1:** Functional Decomposition of System and Subsystems

## 2.4 Benchmarking Results

Only two products currently exist that are immediately comparable with Might-E Wheel: FlyKly and Copenhagen Wheel (See Figures 1-1 through 1-4). Other electric conversion kits exist, but they require the separate purchase of batteries which must be externally mounted to the bike frame. Might-E Wheel, along with FlyKly and Copenhagen Wheel, provides the batteries as part of the system for ease of purchase and user-friendly installation and operation.

**Table 2-5:** The Important Specifications of Might-E Wheel’s Competitors

	<u>FlyKly</u>	Copenhagen Wheel
Price	\$1,099	\$949
Power Delivery	Pedal Assist	Pedal Assist
Interface	Mobile App	Mobile App
Top Speed (km/h)	25	25
Range (km)	40	50
Power (W)	250	350
Weight (kg)	3	5.9

While Might-E Wheel sets out to solve the same problems as these competitors, there are a few major system differences worth emphasizing. First, they both run using pedal assist systems only, whereas Might-E Wheel uses a throttle to deliver its power. Their pedal assist systems increase their range specifications, as human power is also inherently used in those tests. For example, if the wheel is set to amplify the rider’s power by 2 times their input and the rider puts in 100 W, the motor will put in 100 W. The other main difference is that both competitors use a mobile app interface, which requires the user to own a smartphone and mount it to the handlebars; Might-E Wheel wanted to avoid this type of interface and user requirement, reinforcing the decision to use a full-power electric throttle. A smartphone interface would be unreliable if the rider’s phone battery died. Also, by eliminating the need for a compatible smartphone when using Might-E Wheel, we are able to equip even more people with sustainable transportation.

### **2.5 System Level Issues, Options, Tradeoffs, and Rationales**

Issues typically arise in the design process that forces the designers to make decisions that involve tradeoffs. There are numerous shapes that the system can take, each with its own advantages and disadvantages. Some issues/options that the Might-E Wheel faced included the size and weight, optimizing the range, the wires and electrical connections, and the approachability vs. the functionality.

The first significant tradeoff the team faced was whether or not to enclose the entire system within the hub of the wheel. Doing this would allow for simpler wheel installation, but

would limit the space available for the batteries and electronics running the system. Instead, the team opted for a fender design that mounted on the external axle of the hub but was still no wider than the rear fork of the bike. This allowed for efficient mounting of the proper amount of batteries and electronics.

The bigger the wheel is, the bigger and more powerful the motor can be. However, more batteries would be needed to power a bigger motor for the same range, adding to the overall weight of the product. This would make the user's bike heavier and more difficult to transport. Therefore, the decision was made to use a motor rated at 200 to 400 W in order to efficiently power the wheel without needing a large number of batteries.

Range was also given consideration in the design. If the wheel has a good stream of power but cannot transport the user on a short or medium commute, then it is useless. Extended range incorporates more batteries, which again adds to the overall weight. Four Li-ion battery packs were chosen to power the system. Each pack is rated at 11.1 V and 10.2 Ah (113 Wh). The four battery packs weighed around 2 kg in total, a small addition to the system that would not weigh slow the rider too much.

A large issue facing the Might-E Wheel was that of electrical connections. A throttle is desired to be connected to the wheel, but simplicity of installation must be maintained. Attaching a wire to a rotating hub can cause many problems. Other conversion kits solve this problem by connecting to a user's smartphone, but the Might-E Wheel team saw this as an unnecessary, complicated, and dangerous feature. Therefore, it was decided to use a wireless connection between the throttle and motor for optimized safety and ease of installation and use.

The final trade off related to functionality vs. approachability. The wheel could be made into the most functional conversion kit on the market, but it would involve very complex installation and user choices, in addition to a bulkier design. The Might-E Wheel aims to make the user experience - from installation to use - as easy and pleasant as possible.

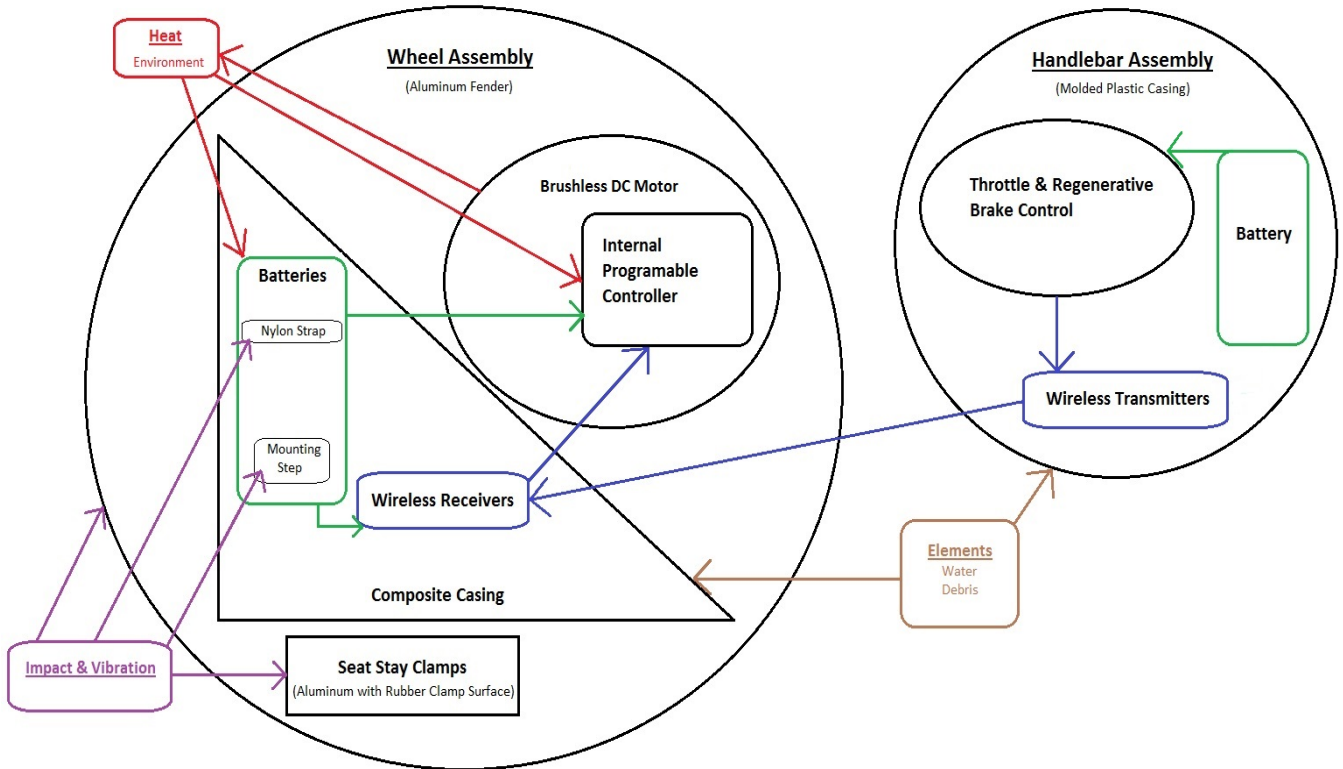
Therefore, functionality on the extreme end (1000 W motor or external batteries) was sacrificed to improve the overall experience of the product.

## 2.6 Systems-Level Overview

The system is made up of two main subsystems that communicate wirelessly. The wheel assembly includes the motor, wheel, batteries, supporting structure, and wireless electronics. The handlebar assembly includes the throttle, regenerative brake, and wireless electronics.

## 2.7 Subsystem Breakdown

Figure 2-2 displays the integration of both subsystems and external inputs.



**Figure 2-2:** Layout of System-Level Design with Main Subsystems

### **2.7.1 Wheel Assembly**

The wheel assembly is centered around a brushless DC electric hub motor spoked in a 26" bicycle rim. An aluminum fender mounts onto both sides of the axle and goes over top of the wheel. This fender includes aluminum steps and nylon straps that restrain the four battery packs used to power the motor. Two wireless receivers are also mounted, serving to facilitate the connection to the handlebar assembly. Finally, two composite cases provide a physical defense for the batteries and electronics from both the weather and contact with any external object.

### **2.7.2 Handlebar Assembly**

The handlebar assembly consists of a thumb throttle and a regenerative braking lever, both of which were designed for our specific motor. Each component is powered separately by two AA batteries and is connected to a wireless transmitter in order to communicate with the wheel assembly.

## **2.8 Team and Project Management**

Managing a project of this scale was a job within itself and was made up of many different components. The following section details these components and the team's project management approach.

### **2.8.1 Challenges & Constraints**

Lack of experience and expertise in the field led to challenges in the design process. Multiple iterations of certain parts of the design and fabrication processes were required because not every interaction was understood at the time. This led to a bit of delay in the full fabrication and testing of the product.

### **2.8.2 Budget**

The budget was based on necessary parts and restrictions based on funding received to date. Might-E Wheel received a total of \$2,500, with \$500 from the Roelandts Grant and \$2,000 from the SCU School of Engineering. The discrete budget can be found in Appendix A. The



majority of the budget was allocated for specific parts, but money was also used for testing materials and repairing the bike used in the project.

### **2.8.3 Timeline**

The timeline is laid out in the Gantt chart in Appendix B. The project began at the end of September with initial research into existing products and what needed to be improved upon. Grant proposals were also submitted early in the process (October) and continued to mid-November, terminating with a venture capitalist pitch. An analysis of customer needs began in November. A range of potential customer, from current electric bicycle users to people with little to no knowledge of electric bicycles were interviewed to gain an understanding of their interest in a product of this type and what they would expect from it. From these needs, features, and requirements a design was developed. With identified features, a more detailed budget was formed.

The system requirements were analyzed to determine the motor and battery sizes needed. With this in mind, the team was able to begin the design process. The design process began in January with initial system design concepts and a mockup to represent the general concept. The design process for all subsystems lasted through March, when parts were ordered. Fabrication took place through March and April. May was for testing and presenting the project at the Santa Clara University Senior Design Conference

### **2.8.4 Risks and Mitigations**

In the final assembly of the design, several risks were faced in possible failure of parts or in the system not working properly when assembled. System risks included calibration of the regenerative brake and throttle for full power electric. Wire management and battery safety also presented risks, along with the natural safety risks of machining the parts used in the product. These risks were thought of ahead of time, and careful precautions were taken to mitigate many of them. The full list of safety risks and mitigations can be found in Appendix C.

The one risk that was not fully mitigated was the shorting of the batteries. Their mounting steps rubbed off the protective casing on one of the battery backs; this caused two of the packs to short circuit together with the support structure. They exploded and were thereafter unusable. No one or anything else was harmed, but this malfunction did prevent the team from completing one of its tests. This risk could have been mitigated by not mounting the battery packs directly on metal, and instead using some sort of insulating material between the two.

### **2.8.5 Team Management**

The team divided up the work as equally as possible for the project and held each other accountable for due dates. The mechanical engineers were all responsible for the design of the system. Once the design had been completed, the team worked on the production of the mechanical and electrical systems in parallel for increased efficiency. Two of the mechanical engineers (Daniel Doke and Zach Jesberger) were responsible for the machining of parts and assembly of the system. The other mechanical engineer and the electrical engineer (Abby Grills and Jared O'Rourke, respectively) were responsible for the battery, motor, and wireless testing. These two divergent teams paralleled each other and converged at the end of the fabrication process.

The only large issue faced in the team management was the coordination between the schedules of the four team members and two advisors. It was very difficult to find times when everyone was free and certain members had to make sacrifices at some points.

Overall, it was a positive and fruitful team dynamic and experience.

## **3. SUBSYSTEM DESCRIPTIONS**

The main subsystems consist of the wheel assembly and the handlebar assembly. This chapter analyzes the functions and components of each subsystem.

### **3.1 Rear Wheel Assembly**

The final design consists of a fender like structure that mounts on both sides of the axle and goes over the top of the wheel, as well as the wheel itself. This design was ultimately chosen

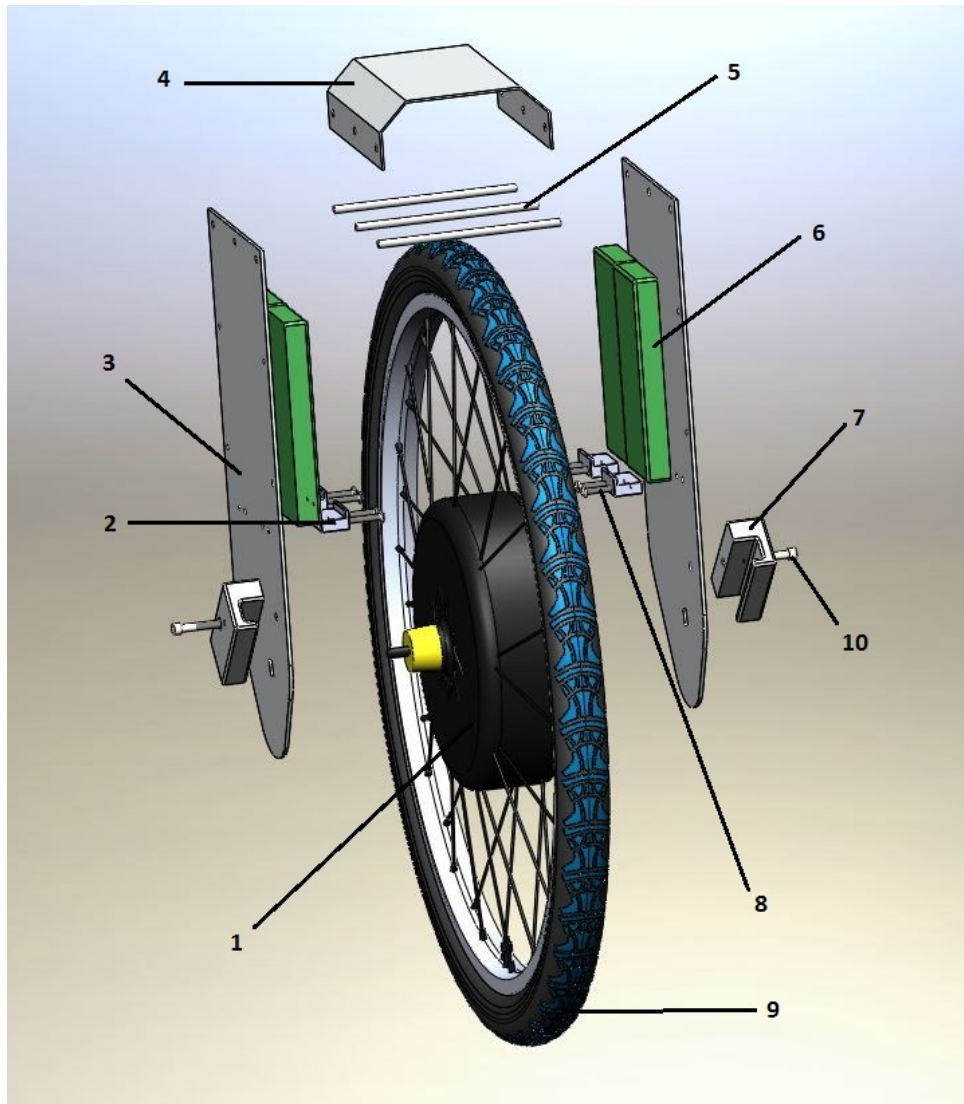
because it provided more space to store batteries and other components, resulting in a longer range and more powerful wheel. Figure 3-1 shows the final design built and assembled onto the bike.



**Figure 3-1:** Might-E Wheel Assembled to the Bike

The rear wheel acts as a vessel to bring together all of the necessary components needed to propel the bicycle. By having all of the needed parts packaged within the seat stays, this aids in the ease of installation and betters the user's experience with the product. It acts as a space to house the motor, batteries, and wireless electronics and is concealed by a protective cover.

Figure 3-2 shows an exploded view of the rear wheel assembly with all of the major parts and components labeled, and Table 3-1 describes the part corresponding to each number label.



**Figure 3-2:** Exploded View of Might-E Wheel and Part Identification

**Table 3-1:** Identified Parts and Descriptions of Figure 3-2

<b>Part Number</b>	<b>Part Description</b>	<b>Quantity</b>
<b>1</b>	Electric Bicycle Hub Motor with Internal Controller	1
<b>2</b>	Battery Support Steps (Aluminum)	4
<b>3</b>	Vertical Supports (Aluminum)	2
<b>4</b>	Top Fender Cover (Aluminum)	1
<b>5</b>	Separation Rods (Stainless Steel)	3
<b>6</b>	Lithium-Ion Battery Pack	4
<b>7</b>	Seat Stay Clamps (Aluminum)	2
<b>8</b>	#10 Pan Head Machine Screws	8
<b>9</b>	26 inch Bicycle Rim and Tire	1
<b>10</b>	¼ inch Cap Head Machine Screws	2

### **3.1.1 Motor**

The motor lies in the center of the assembly at the hub of the wheel and provides the torque needed to propel the rider forward. It is also used for regenerative braking; the motor has the capability of becoming a generator to provide auxiliary power to extend the life of the batteries. The Golden Motor Smart Pie 4, shown in Figure 3-3, was chosen for Might-E Wheel due to its programmable, built in control system and slim profile, which left space on the axle for the battery structure. This space was needed in order to mount the battery structure at the axle.



**Figure 3-3:** The Smart Pie 4 Motor Manufactured by Golden Motor [5]

The Smart Pie 4 is rated for 200 - 400 W, though with the Might-E wheel's specific battery assembly it output 311 W. A defining reason for purchasing this motor was that it is programmable and has an internal control board. Most other electric bike controllers are large and must be mounted externally. This motor enabled design versatility while being powerful enough to propel a bike for our purposes.

### **3.1.2 Vertical Supports**

The vertical supports are the framework that the rest of the assembly relies on. These Vertical Supports can be seen in Figure 3-2 as Part 3 in the assembly and are made up of  $\frac{1}{8}$ " thick 6061 aluminum sheet. This type of sheet was chosen for the high strength to weight ratio as well as its availability and machinability. A plate is positioned and mounted on either side of the axle and on the inside of the rear frame forks.

The vertical supports provide the structure with the majority of its stiffness and ability to house all of the necessary electrical components. To ensure that the design of the structure would sustain everyday use as well as more extreme riding cases (crashes, wind, etc.), the stress the plates might experience was simulated using Finite Element Analysis (FEA). One,

having the structure subject to a 80 km/h crosswind and two, subject to a 270 N impact force at the top of the structure. Further analysis and detail can be found in Appendix F. After conducting the necessary analysis, the plates proved to be able to withstand these conditions when used in conjunction with the seat stay clamps as detailed in Section 3.1.5.

The shape of the supports reflects how the bicycle frame influenced the design of the structure. The bottom of the plate is the most constrained and had to be designed to be able to avoid the tapering chain stay of the bicycle. Therefore, to avoid the constraints of the frame the plates are oriented vertically away from the frame and slightly off-center towards the rear of the bicycle. To ensure that the plate remained vertical and positioned correctly, a computer aided mill was programmed to cut a hole to match the axle shape as well as its resting angle. Cutting the hole as such, this kept the supports oriented vertically, and because the hole was fitted to the axle the tight fit ensures that the hole in the plate will not wear prematurely and will continue to hold the supports vertically.

### **3.1.3 Top Structure**

This fender cover is labeled as Part 4 on Figure 3-2. It is fabricated out of 1/16" aluminum and functions to cover the system and wires, maintain a safe separation distance between the plates, and serve as an aesthetic connecting piece. The piece helps to stabilize the assembly by providing rotational stability to the structure. Its functionality is further reinforced by the separation rods detailed in the next section.

### **3.1.4 Separation Rods**

There are three separation rods that can be identified on Figure 3-2 as Part 5. These rods are made up of 1/4" thick threaded stainless steel. Aluminum threaded rod was considered, however the aluminum rod would be too susceptible to thread damage and the material's strength properties were not sufficient to withstand the forces that the rods may encounter, including impact forces, vibrations, and torsional forces. The stainless steel was found to have the same aesthetic qualities of aluminum but with the strength of steel.

The rods were used for the rider's safety and to ensure the assembly would be able to withstand the challenges that the road may present. With the thread of the rod across the width of the top of the assembly flanged nuts are used on the inside of the structure and tightened to maintain a safe operational distance between the electronics on the inside face of the vertical supports and the rotating wheel and tire running in between both vertical supports. This is imperative to the safety of the rider for any unforeseen loading of the structure because the rods will not allow the plates to deflect toward the rotating wheel, which might cause mechanical failure.

These rods lastly act as a mounting structure to safely be able to run the necessary electrical wire. The rods provide the space needed away from the rotating wheel for the wires to securely be mounted and connected to each battery and component of the assembly.

### **3.1.5 Seat Stay Clamps**

These clamps were designed as a result of the finite element analysis on the vertical supports and part labeled as Part 7 on Figure 3-2. After the yielding of the vertical supports in these tests, it was determined that each support required an additional anchoring point to the frame of the bike. The clamps were machined out of 6061 aluminum blocks in order to stay lightweight but provide sufficient strength. There is one clamp for each vertical support. Each clamp uses rubber padding to ensure a tight fit to the seat stays of the bike. The carved out section is flush with the seat stay while the body stays flush to the vertical support. Each clamp is anchored to the support by a ¼" cap head machine screw (Part 10 in Figure 3-2), washers, and nylon lock nut. The cap head screw was chosen to remain low profile and nestled within the fork. The nylon lock washers were used to prevent loosening upon vibration of the bike and assembly.

### **3.1.6 Batteries**

The batteries are necessary to power the motor and are located within the fender assembly. Li-ion batteries were determined to be the best for our purposes due to their high energy density, low self-discharge, and low maintenance needs. They are expensive batteries, but are very reliable and are used in a wide range of applications.



Custom Li-ion battery packs were determined to be the ideal choice for the project. These batteries were chosen based upon their physical size as well as their energy specifications. Each battery package is comprised of nine separate Li-ion batteries connected and packaged together, which can deliver 11.1 V, 10.2 Ah, and has maximum discharge rate of 14 Amps. Each individual Li-ion battery is a High Power Panasonic Lithium 18650 rechargeable cell that delivers 3.6 V, 3400 mAh, and has a max continuous discharge rate of 6.8 Amps each. These cells were chosen for their high energy density, because most individual cells are rated below 3000 mAh for the identical size cell. Keeping the volumetric space needed for the energy storage to a minimum is important to ensure a longer range as well as to conserve space for other components that will be needed. Based upon calculations in Appendix D, four batteries are connected in series to create a 44.4 V battery pack rated at 10.2 Ah which is capable of achieving about a 24 km range.

### **3.1.7 Battery Support Steps**

Indicated in Figure 3-2 as Part 2, the individual steps can be seen underneath each battery. Since the steps are not going to be subject to major loading conditions, they were machined out of 6061 aluminum stock and designed to simply provide a stable mounting location for each battery.

Each step was cut so that the battery would have a flat step to rest upon, but was also machined to have a small lip towards the inside of the structure. This small lip helps to nest the battery into a secure position and is fully mounted with adjustable nylon straps that are not shown in Figure 3-2 for clarity. Further details about the straps are provided in Section 3.1.8.

### **3.1.8 Battery Straps**

The batteries were strapped into the vertical battery supports with one inch wide nylon adjustable straps. These straps were used to ensure that the batteries will stay in position while the system is operating. However, these straps also simplified battery installation and removal. The straps use low-profile clips that are easy to clasp, giving the user an option to remove and charge the existing batteries.

### **3.1.9 Composite Case**

The inside of the structure is vulnerable to weather exposure and attack from road debris. With the batteries and electronics on the inside of the plates these items are also susceptible to water or being damaged by flying road debris. To protect these important systems a composite casing is used to cover all of the components on the inside of the vertical supports. The casing is not shown in Figure 3-2 for clarity. Although these casings have not been manufactured, their design has been completed.

The casing would be comprised of fiberglass and epoxy resin and would be molded using a plywood mold. The fiberglass is placed within the mold and saturated with epoxy resin being sure to dispose of extra resin. When cured, the case is cut to shape and mounting holes are cut to attach to the vertical supports. Before installation, the case's edge is lined with a thin, weather tight rubber seal to protect against the elements

## **3.2 Handlebar Interface**

The interface that the rider will be using to control the electrical components of the product will provide the necessary functions needed, including accelerating the bicycle and regenerative capabilities. The interface will also be connected to the rear assembly without any physical wires.

### **3.2.1 Throttle**

Several full-power electric bicycle throttles were tested and the thumb throttle best fit our needs of comfort and easy installation. The throttle consists of a retrofitted electric bicycle controller that originally was designed to be wired to the motor (see Figure 3-4).



**Figure 3-4:** Thumb Throttle Used for Might-E Wheel.

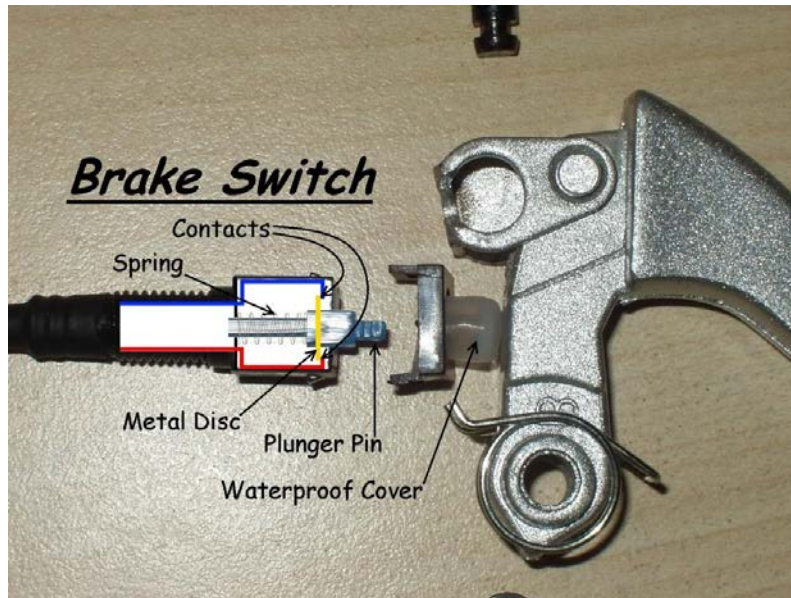
The choice was made to use the thumb throttle that was originally designed to work with our motor in order to save time in both manufacturing and development. The throttle was to be retrofitted to connect to a radio frequency (RF) transmitter, allowing the system to be wireless. The throttle input will be tuned by the control panel for accurate speed control. The throttle will send an analog voltage signal, varying between 1V and 4.25V. Pushing the throttle down by curling the thumb around the handle bar will cause the wheel to accelerate. The RF systems have been tested off of the bike, but have not yet been installed. The team is waiting to install the wireless systems once other necessary tests have been completed.

### **3.2.2 Regenerative Brake**

The regenerative brake feature is assembled by adding components to a standard bicycle brake. The decision to modify a bicycle brake lever was made to aid user comprehension of the feature, as it was decided that people would better understand its utility if it was incorporated in an already accepted brake design.

The modified braking lever sends a voltage when idle and will send a ground signal if activated as a result of the contacts separating from the signal wires. Pulling the brake causes

the main lever to mechanically compress the plunger pin and separate the contacts from the signal wires, thereby eliminating the idle voltage and providing the ground signal. Figure 3-5 shows a schematic of the regenerative brake.



**Figure 3-5:** Regenerative Braking Lever with Labels

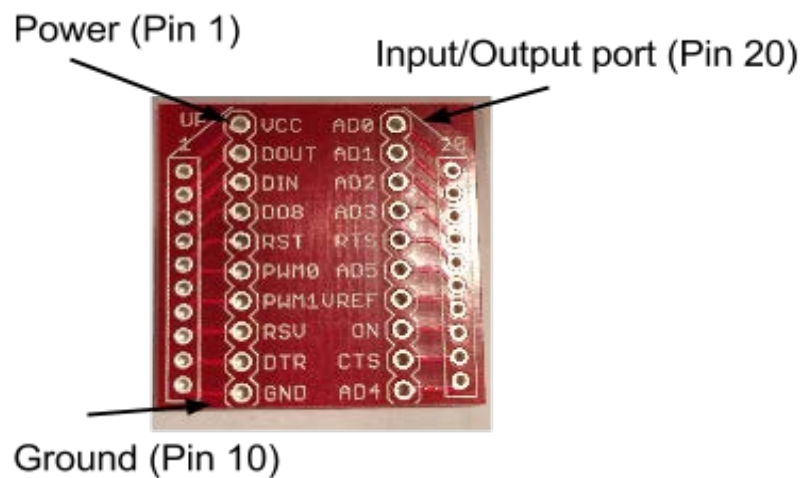
### 3.2.3 Connectivity

For easy installation, all handlebar systems must communicate with the wheel wirelessly. In order to achieve this communication, XBee Series 1 transceivers were used. XBee Series 1 operates between 2.8V and 3.3V. The system requires four XBee Series 1 transceivers, two as transmitters and two as receivers. The two transmitters would be mounted on the handlebar and receive an analog signal from the regenerative brake lever and throttle. These signals will be transmitted to their respective receivers in the wheel housing and will recreate the signal as a digital output. In order to better recreate the signal, a digital to analog converter will be inserted between the throttle receiver and the motor controller for a smoother ride. The signal is discretized in order to be transmitted wirelessly, so for this reason, it must be converted back to analog before it is sent to the motor.

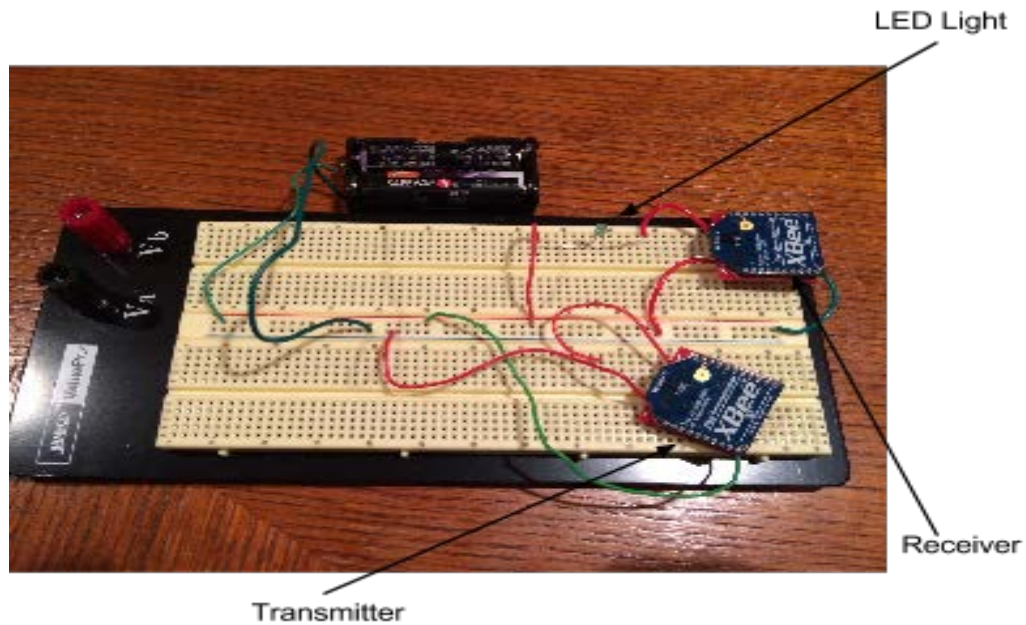
The XBee Transceivers, were programmed using XCTU, a third party software. Through this software, the XBee's were configured, two as transmitters and two as receivers. Each pair of

XBee's, consisting of one transmitter and one receiver, was set to a unique channel so that its respective signals would not interfere with each other.

To test the performance of the XBee pairs, an experiment was designed where each pair was placed on a breadboard, both respective XBee's were powered (power connected to pin 1 and ground connected to Pin 10) and a signal was sent to turn on a LED light. The transmitting XBee was supplied a voltage signal (via Pin 20) and sent it to the receiving XBee where the signal powered the LED connected to the channel pair (via Pin 20). The pin designation of the XBee's can be seen in Figure 3-6 and the experiment performed with the XBee's and the LED light can be seen in Figure 3-7.



**Figure 3-6:** XBee Pin Designation

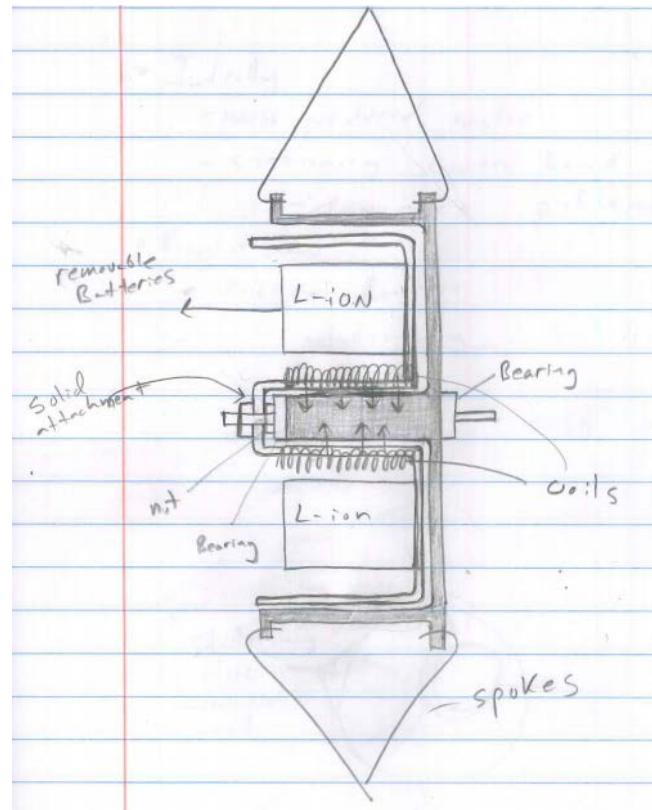


**Figure 3-7:** Xbee Experiment

The experiment was a success in that the signal was transmitted so that the LED was illuminated. However, once the signal was terminated, there was quite a significant delay (of approximately 7 seconds) before the receiving Xbee responded correctly and the LED would turn off. The implication of this delay meant that the regenerative brake would be unable to immediately respond should a user activate the brake. That being said, though the time at which the system responded could be improved upon, the functionality that we designed was still addressed despite the delay.

### **3.3 Design Process**

Two options were considered for the rear-wheel assembly: (1) a readily available motor or (2) a custom fabricated motor. Using a custom fabricated motor could have provided the option to consolidate the subsystems and components as we see fit. The motor could be designed around our constraints and the batteries and controller would be able to be stationary with the stator, as seen in the preliminary design in Figure 3-6.



**Figure 3-8:** A Theoretical Design for a Custom Motor (Cross-Section)

With this design, the batteries would be stationary along with the controller to make the electrical connections much easier. Also, no electrical components will be moving, thus reducing the risk of damaging the electronics. However, a custom designed motor posed a few setbacks. With the tools that are accessible to the team, it would not be possible to fabricate a motor that has the same efficiency as motors on the market today, and it would take much more time to develop a motor to meet the desired specifications. Having an outside contractor build this motor would cost a substantial amount.

Also, a large amount of time for the project would have been spent waiting for the contractor to build the motor and it would have taken away from the educational experience. If our budget were put to manufacturing a motor, the motor would have absorbed far too large a percentage of the budget. The large cost and manufacturing time involved in building a motor was ultimately determined to be too great for an initial prototype and proof of concept.



Due to these factors, the team decided to use a motor that was already designed and manufactured.

An off the shelf motor allowed for the selection of a motor from multiple manufacturers who produce 400 W motors of varying weights and dimensions. The use of a mass-manufactured motor meant the motor would be much more cost effective than a custom-fabricated motor. These motors have been proven to work with the required loads and are available in many sizes. Due to the fender design of the wheel assembly, the size of the motor only affected the system by the amount of axle length it took up, as well as how much it weighed. The more space left on the axle between the dropouts on the bicycle (135 mm spacing), the more space there would be for energy storage.

#### **4. SYSTEM INTEGRATION & TESTING**

Once the design process and fabrication of Might-E Wheel was completed, it was necessary to test the system with regard to its design specifications. The specifications tested were top speed, range, weight, and installation time. Table 4-1 shows the testing results, and each following sections of the chapter details the procedure for each test.

**Table 4-1:** The Various Specifications Tested and Results Achieved

<b>Test Specification</b>	<b>Design Specification</b>	<b>Result</b>
Top Speed (km/h)	32	27.5
Range (km)	24	41
Weight (kg)	6.8	11
Installation Time (min)	30	20

##### **4.1 Top Speed Test**

This test was performed by having 4 different users throttle (without pedaling the bike) until peak speed was achieved. This allowed for a measurement based entirely on the power of the motor and batteries, and not human power. The speed was measured and recorded using a Specialized Bikes Speedzone Cyclocomputer Sport; this product is a bicycle computer that uses a magnet and sensor mounted on the front wheel and can display maximum speed,



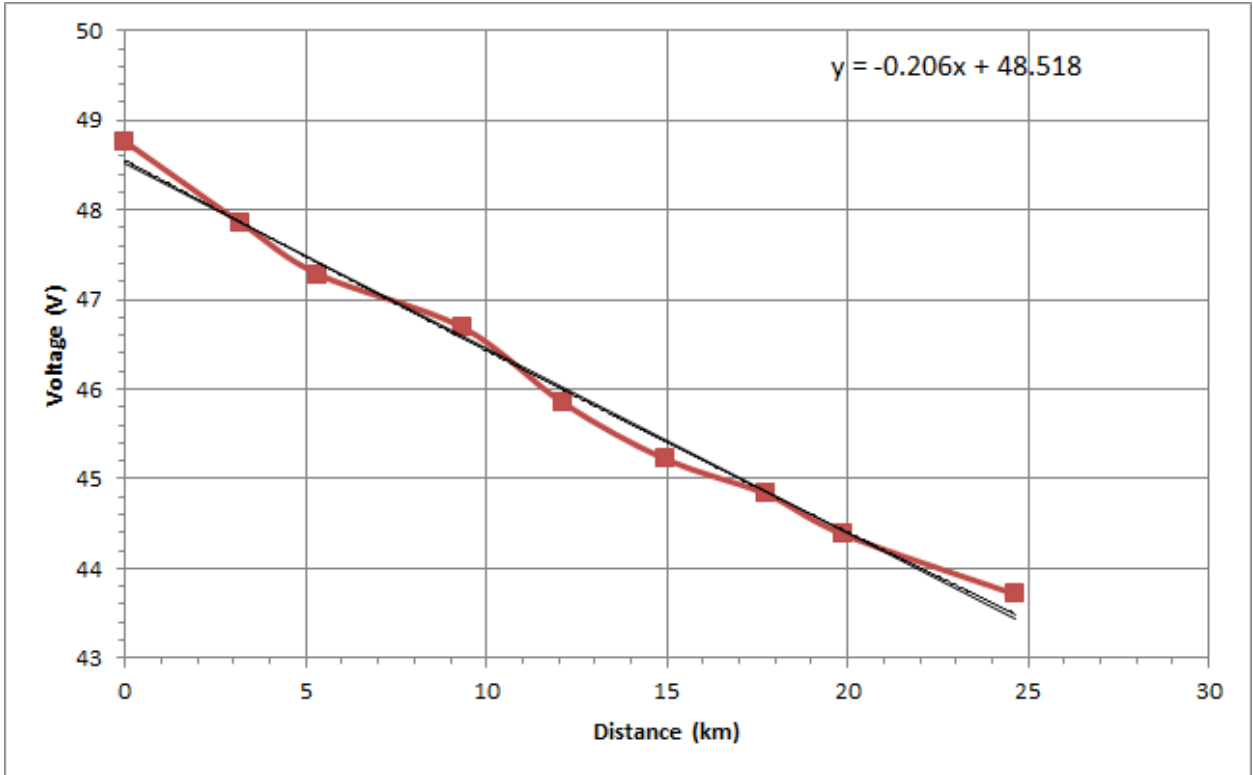
average speed, and range of a trip. The maximum speed achieved was 27.5 km/h. While this fell slightly below the design speed of 32 km/h, it was deemed an acceptable top speed. Higher speeds were reached when the riders used a combination of pedaling and throttling; however, this test was meant to measure determine the speed achieved when using the Might-E Wheel electric system alone.

## **4.2 Range Test**

A test of range was conducted in order to find the total distance Might-E Wheel could carry a bike and rider on a single battery charge. The calculations in Appendix D show that the system was predicted to be able to transport the rider for 32 km. The range test was completed by riding the bike around the Santa Clara University campus with the rider moving at an average speed of 22 km/h. No human power was added by pedaling, leaving the bike powered only by the motor. As few stops as possible were taken as possible because acceleration takes additional energy.

The Specialized Bikes Speedzone Cyclocomputer Sport was used to monitor speed and track distance. The Strava Cycling app was also used to verify distance, as well as time. Stops were taken periodically in order to measure the nominal voltage of the battery pack and the voltage of each individual battery. The batteries were charged to be relatively even and initial voltage measurements of each battery, as well as the whole system were taken before beginning the test.

The bike was run for 24.6 km for a total of 83 minutes run time, resulting in a nominal voltage drop from 48.76 V to 43.71 V. The change in voltage with distance was fairly linear, as seen in Figure 4-1.



**Figure 4-1:** The Nominal Voltage of the Battery System with Respect to Distance, where  $y$  Represents Voltage and  $x$  Represents Distance

The motor could still run after the 24.6 km of testing, but testing was concluded there for the safety of the batteries and the rider. At this point, there had been a noticeable loss in power as the bike could no longer achieve as high of a top speed, but the testing speed of 22 km/h was still able to be maintained. The cutoff voltage of each individual battery is 7.2 V, or 28.8 V nominal for the entire pack, but the motor cannot be powered properly once the pack voltage drops below 40 V. This is also beneficial in keeping the batteries safe, as they never fully reach their cutoff voltage. Ideally, this would also extend the battery life cycles.

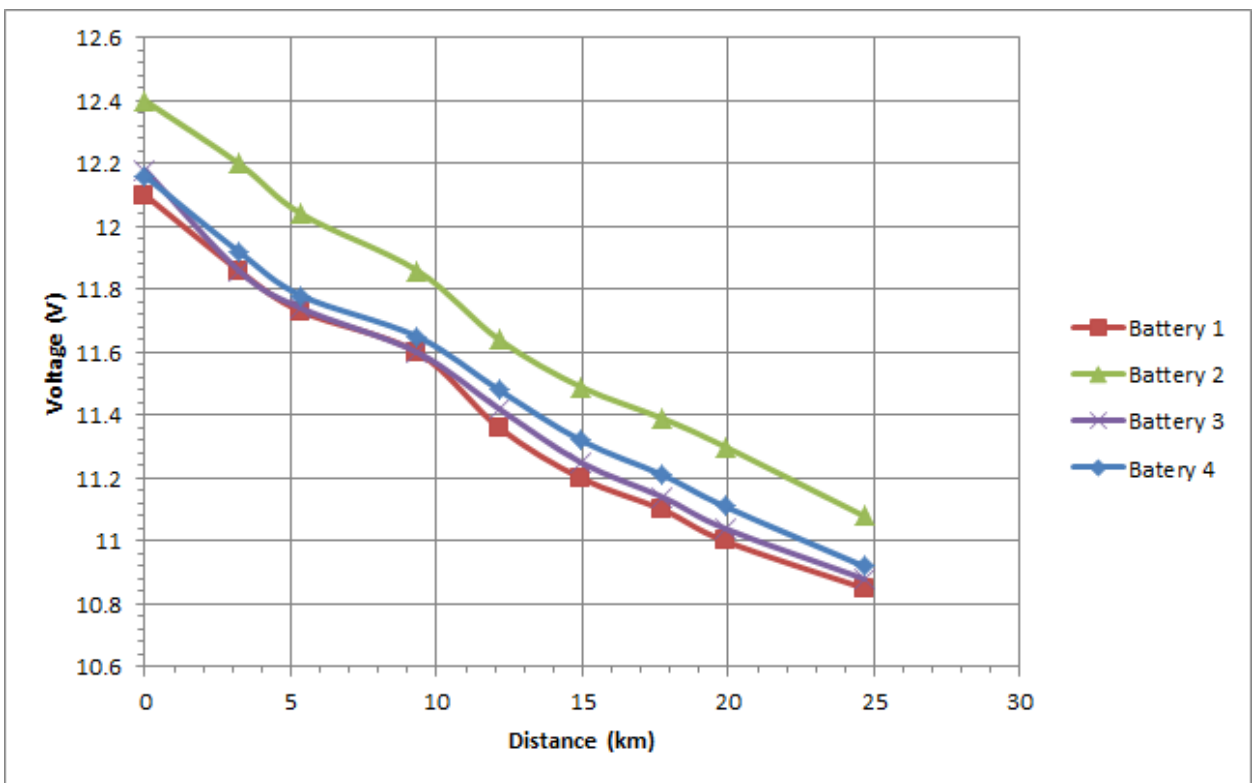
The nominal voltage drop of the battery pack with distance can be represented by

$$y = -0.206x + 48.518, \tag{eq. 4-1}$$

where  $y$  represents voltage and  $x$  represents distance.

Equation 4-1 was used to extrapolate the total range if the batteries were continued to be drained to a nominal 40 V. It was found that at this voltage, the range would reach 41.35 km. This range significantly exceeded the goal range of 24 km.

An additional concern was the even discharge of the batteries. For this reason, all of the batteries were read for voltage at each stop. The voltage changes of each battery are shown in Figure 4-2. The batteries discharged at a consistent rate, with all batteries discharging similarly.



**Figure 4-2:** The Voltage of Each Battery with Respect to Distance

The total range could have been affected by the stops taken during testing. A total of 15 stops were taken. These stops were not considered significant in the data, because an actual ride would also include occasional stops, requiring the rider to accelerate additional times, and consuming more power. The range specification was exceeded despite these stops and the range may have been even longer with only the initial acceleration from zero.

### **4.3 Weight Test**

The weight test was performed by simply placing the system with all its components onto a scale and recording the result. The system weighed 11 kg. This was 4.2 kg heavier than the intended weight, but this variation was not deemed to be important due to the achievement of a good top speed and the fact that the weight of riders would likely vary by much more than 5 kg.

### **4.4 Installation Time Test**

The installation time test was performed by preparing the Might-E Wheel as it would be sold on the market, with all subsystems were assembled. The only installation necessary was to secure the wheel onto the bike frame, mount and anchor the frame clamps to either side of the wheel assembly, and mount the handlebar assembly on the handlebars of the bike. After testing this with 3 different users, the maximum installation time was found to be 20 minutes. This result was excellent due to it being shorter than the target installation time. This is one of the most user-friendly features of the Might-E Wheel.

## **5. ENGINEERING STANDARDS AND REALISTIC CONSTRAINTS**

All engineering projects are driven by constraints, and many projects must conform to certain engineering standards. These constraints and standards define the technical boundaries that project cannot cross.

Might-E Wheel will help take cars off the road, resulting in reduced emissions, improved public health, and reduced spending on transportation. Adoption of Might-E Wheel will make an impact across economic, social, health and safety, political, and environmental lines.

### **5.1 Health & Safety Impacts**

The air we breathe has a large effect on our health. According to the *American Lung Association State of the Air 2011* report, over 154 million people, making up slightly over half the nation, are exposed to highly polluted air every day [6]. With 75% of carbon monoxide emissions resulting from automobiles, minimizing transportation by car serves as a strong starting point to improve public health [7].

Researchers at the University of Wisconsin - Madison conducted a simulation modeling the impact of eliminating automobile travel for round trips of 8 kilometers in distance or less in 11 United States metropolitan areas. The study concluded that eliminating these trips would result in approximately 608 fewer deaths per year based on improved air quality alone [8]. The health impacts of air quality are also evident in the fact that 15% of children's asthma cases are linked to living near a busy road [9].

Might-E Wheel uses minimal electric power and creates zero road emissions, improving air quality in highly populated areas. The extended range of Might-E Wheel allows for more trips that can be made by electric bikes, thereby taking more cars off the road.

## **5.2 Social Impacts**

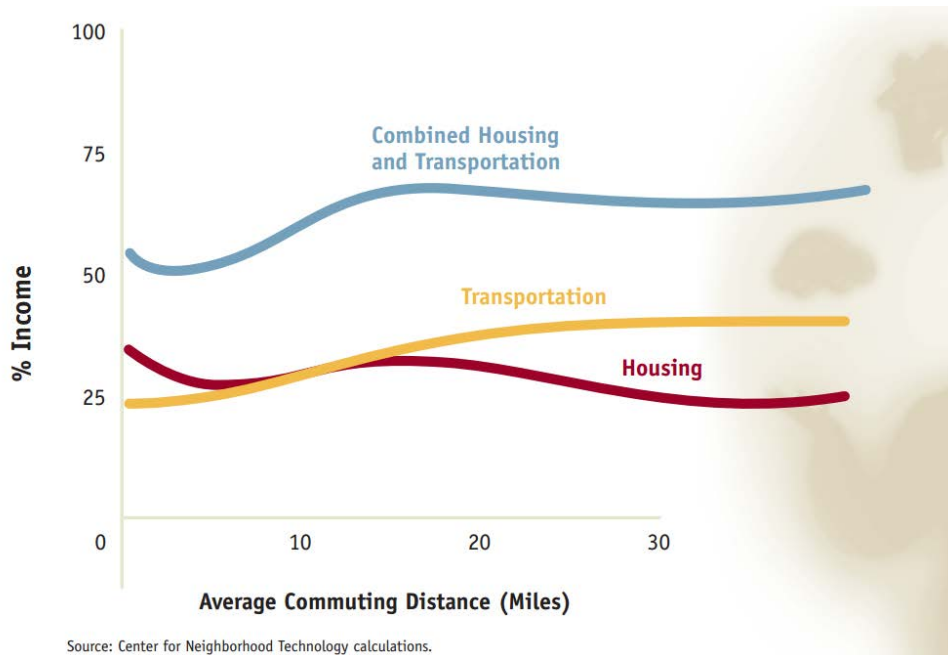
Most automobile usage in the U.S. could be replaced, considering 69% of car trips are less than 3.2 km (2 mi) [10]. In the first few minutes after an automobile is started, it emits the highest amount, making up almost a quarter of its emissions throughout an entire drive [11]. These short trips can easily and comfortably be replaced by electric bicycles. Replacing just 1 in 5 of these trips under 3.2 km with travel by Might-E Wheel instead of by automobile would account for 14% of automobile usage in the U.S.

A study conducted by MIT on bicycle data in Lyon, France found that the speed of bicyclists on manual bikes exceeds that of cars during rush hour by 50% and tends to match the speed of cars in European inner cities [12]. The average of the rides recorded were 2.49 km in distance over 14.7 minutes [13]. This distance could be expanded and time shortened by the adoption of Might-E Wheel. Additionally, traveling with Might-E Wheel would be more time efficient at busy hours and reduce the frustrations of sitting in traffic.

The added time, frustration, and cost of parking is also minimized by traveling by bicycle. The space required to store one car can typically hold around 10 bicycles [14]. Since bicycles are smaller, storage is easier and less expensive to provide. Adopting Might-E Wheel on to an existing bike means that the bike will maintain its small dimensions and easy storability.

### 5.3 Economic Impacts

The Might-E Wheel has huge potential economic impacts through replacing more expensive forms of transportation for commuters. In a 2006 study by the Center for Housing Policy, regions from all around the nation were examined to compare housing and transportation costs in all sorts of areas (urban, rural, suburban, etc.). Figure 5-1 shows the percentage of income taken up by housing and transportation in relation to commuting distance.



**Figure 5-1:** Transportation and Housing Costs as Functions of Average Commuting Distance [15]

It was found that transportation, on average, accounts for at least 25% of the income for working families (this income was assumed to be \$50,000-\$60,000 per year) [15]. This annual transportation cost equates to around \$13,000 per year. This is an extremely high percentage of total income that could be better allocated for families. The Might-E Wheel, in production, would cost the consumer about \$1,000, while a standard bike costs about the same. This equals an initial investment of \$2,000 on a sustainable form of transportation. The only maintenance costs to the wheel itself should be battery replacements (\$300) after two years and occasional tire replacements. There may also be additional bike repairs needed occasionally, adding up to an estimated \$250 per year for each bike.

#### **5.4 Environmental Impacts**

Metropolitan areas have much worse air quality than their rural counterparts due to the high volume of cars and other gas vehicles that constantly flow through them. In 2012, a simulation was performed in order to understand the possible effects of eliminating 50% of short car trips (< 8 km) in metropolitan areas and replacing them with bicycle rides. In the simulation, the specific emissions of interest were fine particulates. It was found that this reduction of automobile trips would reduce the average annual amount of fine particulates in the air by 1.0-2.0% [16]. These results could be achieved by the use of the Might-E Wheel and other electric bikes, reducing emissions and making the world healthier.

Further environmental issues stem from the batteries used in the Might-E Wheel. Lithium-ion batteries were used for their excellent performance and rechargeability. Issues that arise from these are that they cannot come in contact with fire or excessive water. Fire could cause the batteries to explode while placing the batteries in water could cause the batteries to rupture and release harmful gasses. Additionally, the batteries must be disposed of properly. They are not allowed to be thrown away into the trash, since harmful chemicals can be released into surrounding water and soil sources [17]. Instead, they should be recycled in accordance with each state's respective guidelines.

#### **5.5 Manufacturability**

With the Might-E Wheel's current design the entire product is manufacturable without the aid of computer automated machining (CAM). With the use of metal cutting tools and fasteners the current model can be built and used as a working prototype. In regards to the prototype's current design this product cannot be mass-produced economically. The mass production of the Might-E Wheel would require too much manufacturing time per product. However, the Might-E Wheel's first prototype would not be mass produced and if the Might-E Wheel was in fact to go into mass production a separate design would be used. The development time for the first prototype was fast due to the nature of the design and was designed as such to be able to manufacture the product on-campus. For the second design to be mass produced, the development time would increase significantly, yet the production time per product would be greatly reduced in comparison to the first prototype. The

development time would greatly increase because the new design would have no battery fender and would have the batteries within a case in the hub with the motor. To accomplish this complex design, special aluminum molds, which also increases pre-production cost, need to be cut with computer aided machining to create the needed components to house all of the components. Once the molds are cut, it is only a matter of filling and refilling of the molds and assembling the parts to create a production sequence. This process has a high pre-production cost but this would be the only way that the Might-E Wheel can be mass produced.

## **5.6 Realistic Constraints**

Constraints to the design based on legal, size, speed, and range set the design parameters and limitations.

### **5.6.1 State Laws**

Laws and restrictions on electric bikes vary throughout the US and throughout the world. This project is being done in California, so the California state laws were referred to for restrictions. According to the California Highway Patrol, an electric (or “motorized”) bicycle must have a motor that (1) outputs no more than 1000 W of power, (2) propels the bike no faster than 32 km/h on level ground, and (3) increase the speed of the bicycle if human power is propelling it faster than 32 km/h [18]. These all create constraints for the motor size and speed of the system.

### **5.6.2 Size**

A major engineering constraint of the project is size. We are volumetrically confined within the hub of a 135 mm wheel axle spacing between the inside of each side of the fork. Exceeding this space would disable the existing bicycle from operating properly, which would make the project a failure. Therefore, it is certain that the motor, batteries, and electrical equipment (control board, sensors) must be packaged within the hub of a bicycle wheel.



### **5.6.3 Weight**

Another engineering constraint to be considered is weight. The heavier the system is, the more power is required to run it. High weight would also make the system bulky, difficult to install, and difficult to transport. A lightweight, efficient system is desired in order to make a usable and appealing system that maximizes performance.

### **5.6.4 Range**

Range is a defining constraint of the system. Users will buy the product due to its ability to transport them over a certain distance. If the product is unable to deliver a consistent and worthwhile transportation distance, then appeal to the consumer becomes low. Therefore, it is important to ensure that the product lives up to its target design range of 24 km on fully-electric power.

### **5.6.5 Cost**

Finally, cost is a heavy constraint on the project. This includes prototyping, testing, and final product costs. The project has a specific budget (see Appendix B) that it cannot exceed. It has received a finite amount of money from funding sources. Should these costs be exceeded when ordering materials and prototyping, then the project is essentially dead. Additionally, the goal of the project is to create a product that is appealing and comes at a fair cost to consumers. Should a product be created that is many thousands of dollars, then it is very unlikely that anyone would buy the product. The end cost must be kept in mind through the entire design, fabrication, and testing stages.

## **6. SUMMARY AND CONCLUSION**

### **6.1 Summary**

The Might-E Wheel aims to improve upon current methods of transportation by designing a wireless, electric rear wheel replacement that upgrades a bicycle to electric power. This was accomplished by modifying a Golden Motor Smart Pie 4 motor, which was attached to a wheel, and creating a housing that included Li-ion battery packs, wires, and electronics. This assembly will communicate wirelessly with a throttle and brake lever that will attach to the

handlebars of the bike. The assembly will provide the user with both throttling and regenerative braking capabilities to maximize the user experience and extend the range. The project aspires to achieve an approachable, easily installable, and user-centric end product that extends the range and improves the experience of human transportation.

## **6.2 Future Work**

Going forward, there are a few improvements which could be made to Might-E Wheel had there been more time. In the short term, more improvements should be made to lower the market entry barrier to Might-E Wheel adoption and make it more widely adaptable for users. In order to do this, the design should be further iterated upon to make the Might-E Wheel easier to install and cheaper. In order to make Might-E Wheel a more viable commuting option, the structure should be made smaller and lighter weight. As for the long term, Might-E Wheel could be a catalyst in growing consciousness of green transportation technologies. This could be done by partnering with ride-sharing programs that already exist in cities to install Might-E Wheel onto shared bicycles. Converting these bicycles will cost less than replacing them and encourage more people to commute by bike. Hopefully, wide-scale adoption of Might-E Wheel will further spur individuals to shift towards electronic means of transportation and ultimately lead to an improvement in our nation's infrastructure, particularly with regards to bicycles.

## BIBLIOGRAPHY

- [1] Cabanatuan, Michael. "Tied up in traffic as bad as L.A.'s?." *San Francisco Chronicle* (CA) 11 Feb. 2013, 5star-dot, Metro: A1. NewsBank. Web. 15 Oct. 2014.
- [2] Neville, Tim. "Over the Alps on a Bike With a Boost." *The New York Times*. The New York Times, 27 Aug. 2011. Web. 04 Nov. 2014.
- [3] FlyKly cited 2015  
[Available online at <http://flykly.com/>]
- [4] Copenhagen Wheel cited 2015  
[Available online at <https://superpedestrian.com>]
- [5] *Programable, Construir-en Controller, Magic Pie 3 Hub Motor E Bike Kit Y Smart Pie Electric Bicycle Conversion Kit. Made-in-China.com*. Web. 08 June 2015.
- [6] "State of the Air 2011." *American Lung Association*. American Lung Association, 2011. Web.
- [7] "Cars, Trucks, Buses, and "Nonroad" Equipment." *EPA*. Environmental Protection Agency. Web. 27 Apr. 2015.
- [8] Grabow, Maggie L. et al. "Air Quality and Exercise-Related Health Benefits from Reduced Car Travel in the Midwestern United States." *Environmental Health Perspectives* 120.1 (2012): 68–76. *PMC*. Web. 27 Apr. 2015.
- [9] "A Breath of Fresh Air Please." *The Lancet* 377.9769 (2011): 875. The Lancet, 12 Mar. 2011. Web.
- [10] *Urban Transport. Transport Research & Innovation Portal*. European Commission's Directorate General for Mobility and Transport, July 2001. Web.

- [11] "Air Quality and Exercise-Related Health Benefits from Reduced Car Travel in the Midwestern States" *Environmental Health Perspect.* 2012 January. Web.
- [12] "Cyclists Pedal Faster On Wednesdays, Reveals Smart Bike Data." *MIT Technology Review*. MIT, 1 Dec. 2010. Web. 27 Apr. 2015.
- [13] "Cyclists Pedal Faster On Wednesdays, Reveals Smart Bike Data." *MIT Technology Review*. MIT, 1 Dec. 2010. Web. 27 Apr. 2015.
- [14] Litman, Todd. "Evaluating Active Transport Benefits and Costs: Guide to Valuing Walking and Cycling Improvements and Encouragement Programs." *Victoria Transport Policy Institute*. Victoria Transport Policy Institute, 27 Feb. 2015. Web.
- [15] Lipman, Barbara J. "A Heavy Load: The Combined Housing and Transportation Burdens of Working Families." Center for Housing Policy (2006): 1-21. Nhc.org. National Housing Conference + Center for Housing Policy. Web.
- [16] Grabow, Maggie L., Scott N. Spak, Tracey Holloway, Brian Stone, Jr., Adam C. Mednick, and Jonathan A. Patz. "EHP – Air Quality and Exercise-Related Health Benefits from Reduced Car Travel in the Midwestern United States." Ehp.niehs.nih.gov. Environmental Health Perspectives, 2 Nov. 2011. Web. 27 Apr. 2015.
- [17] Agoston, George A. "Health and Safety Hazards of Art Materials." *Leonardo* 2.4 (1969): 373-82. Www.nrel.gov. National Renewable Energy Laboratory. Web. 27 Apr. 2015.
- [18] "Motorcycles and Similar Vehicles." *California Highway Patrol*. CA.gov, 2014. Web. 09 Dec. 2014.
- [19] "PSF to MPH Conversion Chart." Bristolite Daylighting Systems. N.p., n.d. Web. 26 May 2015.

[20] "Drag Coefficient." Drag Coefficient. The Engineering ToolBox, n.d. Web. 07 June 2015.

## Appendix A: Budget

<b>Budget Update</b>				
<b>TEAM</b>	Might-E Wheel			
<b>Date</b>	March 9th, 2015			
<b>INCOME</b>				
<b>Category</b>	<b>Source</b>	<b>Sought</b>	<b>Committed</b>	<b>Pending</b>
Grant	Roelandt's Grant	\$1,000	\$500	
	SCU School of ENGR	\$2,000	\$2,000	
	<b>TOTAL</b>	<b>\$ 3,000.00</b>	<b>\$ 2,500.00</b>	<b>\$ -</b>
				<b>\$ 2,500.00</b>
<b>EXPENSES</b>				
<b>Category</b>	<b>Description</b>	<b>Estimated</b>	<b>Spent</b>	<b>Pending</b>
Bike	Full Bike Frame	\$271.88	\$271.88	\$0.00
	Cassette Tool, Cable, Spacer	\$15.98	\$15.98	\$0.00
	Tube	\$8.70	\$8.70	\$0.00
	Chain	\$10.00	\$10.00	\$0.00
	Sprocket	\$16.31	\$16.31	\$0.00
Wheel Assembly	Motor	\$356.73	\$356.73	\$0.00
	Batteries	\$630.64	\$630.64	\$0.00
	Support Substructure	\$84.38	\$84.38	\$0.00
	Battery Fixtures	\$50.00	\$0.00	\$50.00
	Battery Straps	\$19.43	\$19.43	\$0.00
	All Thread + Nuts	\$26.01	\$26.01	\$0.00
	Hardware			
Outer Casing	Foam Mold	\$200.00	\$0.00	\$200.00
	Fiberglass + Epoxy	\$150.00	\$0.00	\$150.00
Electrical	Breakout Board for Xbee	\$14.75	\$14.75	\$0.00
	Xbee 1mW Trace Antenn	\$124.75	\$124.75	\$0.00
	Xbee explorer USB	\$24.95	\$24.95	\$0.00
Charger	Single Battery Charger	\$48.14	\$48.14	\$0.00
	<b>TOTAL</b>	<b>\$2,052.65</b>	<b>\$ 1,652.65</b>	<b>\$ 400.00</b>
				<b>\$ 2,052.65</b>
	<b>Net Reserve (Deficit)</b>		<b>\$ 847.35</b>	<b>\$ (400.00)</b>
				<b>\$ 447.35</b>

**Figure A-1: Project Budget**

## Appendix B: Gantt Chart

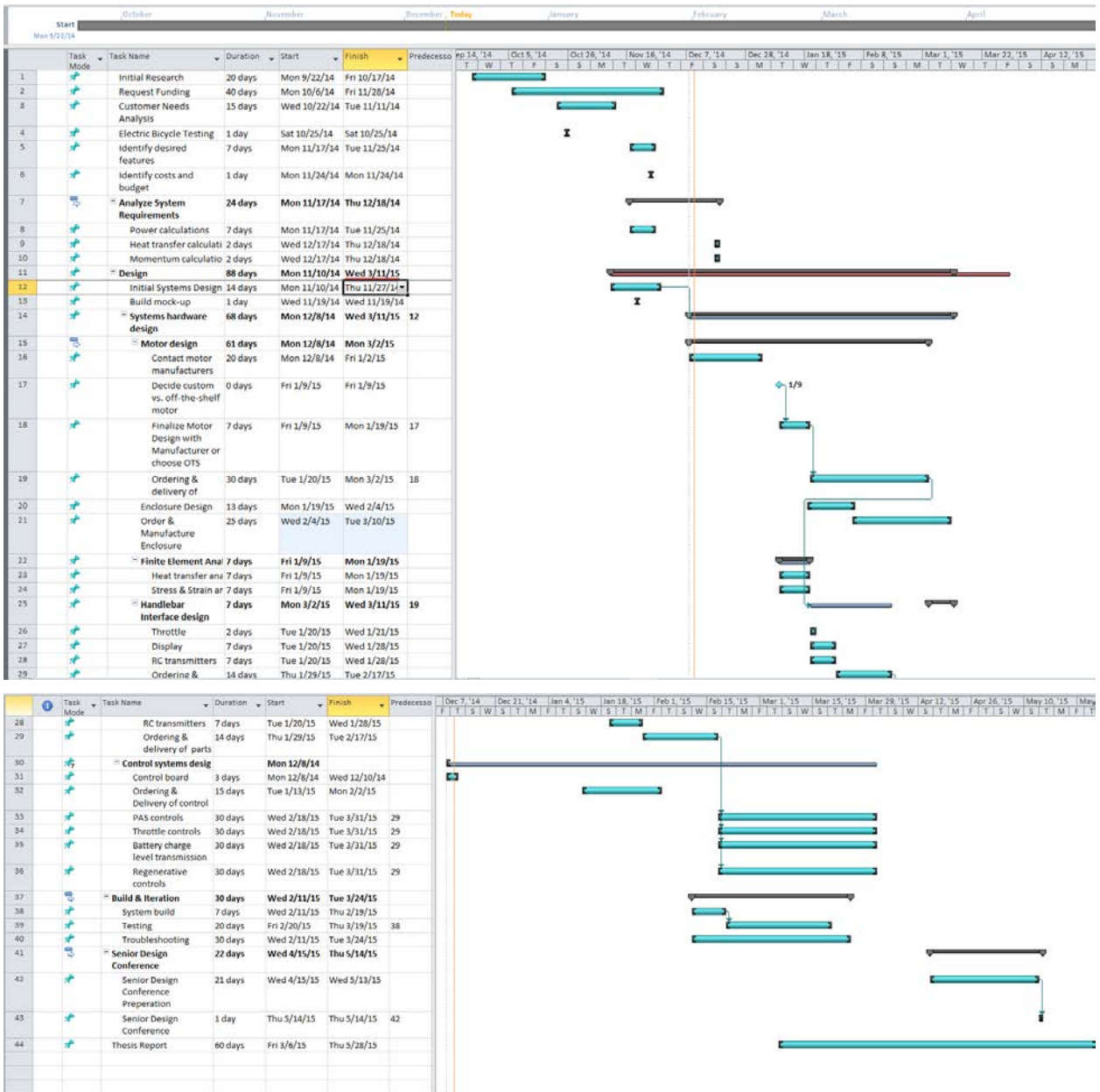


Figure B-1: Detailed Project Timeline

## **Appendix C: Safety Risks and Mitigations**

**Risk:** Lithium Ion batteries. The batteries can chemically combust if not charged/discharged correctly or physically damaged. The stationary batteries could come in contact with rotating parts (due to close proximity). This risk is mitigated by purchasing batteries with a BMS (battery management system) inside of them. Additionally, batteries can explode if overcharged. The BMS manages this risk by restricting the flow during charging.

**Risk:** Rotating wheel and spokes. The system will rotate at a high enough velocity/RPM to harm a person should any part of them come in contact or get stuck in the rotating parts. This could be especially harmful through the testing phase. The risk will be mitigated by only allowing one person near the wheel when it is in use; that same person will be in charge of controlling it. This will mitigate any miscommunications between operator and tester that could end poorly.

**Risk:** Electrical components. The electrical systems must be organized so that they are grounded and safe from shock, as well as being in a dry environment. This risk will be mitigated by ensuring all wires and connections have secure connections and are well-insulated from the environment.

**Risk:** Machining of battery plate. The machine shop will be used to fabricate the battery plate. Many risks are involved with operating a Bridgeport milling machine, including damaging oneself and/or the equipment. All machine shop safety procedures will be followed when machining the plate and we will consult the machine shop manager on all machining before beginning the milling process.

**Risk:** Mounting the batteries and battery plate. The batteries and battery plate must be mounted securely to ensure no movement/rotation that would tangle or tear the wires. This risk will be mitigated by testing the mounts prior to running the motor.



**Risk:** RF signal transferring. The signal must be tested before being connected to the motor. The signal could be wrongly amplified or filtered and result in the wrong signal being sent to the motor. This risk will be mitigated by testing before hooking the receiver up to the motor.

**Risk:** Falling off the bike. When testing the bike, there is a chance that the user could fall off and harm him/herself. This risk will be mitigated by wearing a helmet during testing.

## Appendix D: Electrical Calculations

### Assumptions

These specifications are assumptions made about Might-E Wheel's user as well as the user's desired range and speed.

91 kg - 200 lbs (the human)  
16 kg - 35 lbs (the bike)  
11.17 m/s - 40.2336 kmph - 25 mph (speed)  
8.94 m/s - 32.18 kmph - 20 mph  
20 miles (range)

### Potential Energy

The potential energy equation determines how much energy is required for the bicycle system overcome a certain amount of elevation gain. This equation is required for computing the total energy required to power the whole system.

$$\begin{aligned} E(h) &= mgh \\ &= (107kg) * (9.8 \text{ m/s}) * (h) \\ &= 1048.6 * (\text{height}) \\ &= 1048.6 / (1000 * 3600) = (2.19 \times 10^{-4}) * (\text{height}) \text{ kWh} \\ &= (2.19 \times 10^{-4}) * (\text{height}) \text{ kWh} * 1000 = .219 * (\text{height}) \text{ Wh} \end{aligned}$$

### Kinetic Energy

The kinetic energy equation determines how much energy is required to power the bicycle system at a given speed. This equation is also required for computing the total energy required to power the whole system.

$$\begin{aligned} E(k) &= (.5) * (m) * (v^2) \\ &= (.5) * (107 \text{ kg}) * (v^2) \\ &= 53.5 * (v^2) \\ @ 11.17 \text{ m/s} &\rightarrow 53.3 \text{ (} 11.17 \text{ m/s)}^2 = 6675.136 \text{ joules} \\ &= 6675.136 / 3600 = 1.85 \text{ Wh} \\ &= 1.8542 / 1000 = .00185 \text{ kWh} \\ @ 8.94 \text{ m/s} &\rightarrow 53.3 \text{ (} 8.94 \text{ m/s)}^2 = 4259.92788 \text{ joules} \\ &= 4259.92788 / 3600 = 1.18 \text{ Wh} \\ &= 1.1833 / 1000 = .00118 \text{ kWh} \end{aligned}$$

## Aerodynamics

The aerodynamics equations are needed to determine how much energy is required, per mile, to overcome the force of drag of the given bicycle system. This equation is also required for computing the total energy required to power the whole system.

\*Assume frontal area of passenger and bicycle =  $.4 \text{ m}^2$

\*Assume air density ( $\rho$ ) =  $1.2 \text{ kg/m}^3$

\*Assume drag coefficient =  $.9$  [20]

$$\begin{aligned} E(a) &= .5 * (\rho) * (\text{aerodynamic drag coef}) * (\text{area}) * (v^2) \\ &= .5 * 1.2 * (.9) * (.4) * (v^2) \\ &= .216 (v^2) \end{aligned}$$

for  $E(a)$  measured in Joules/mile

$$\begin{aligned} &= .216 (v^2) * (1609/3600) = .09654 (v^2) \quad v \text{ is measured in m/s} \\ &= .09654 (v^2) / 2 = .04827 (v^2) \quad \text{where } v \text{ is measured in mph} \end{aligned}$$

## Starts/Stops

The start/stop equations calculate the amount of energy needed to start or stop the given bicycle system. The value found was based off the Tesla Model S, so the equation used required an approximation based off the Tesla Model S data. This equation is also required for computing the total energy required to power the whole system.

$E(s)$  of bicycle approx  $1/23$  of  $E(s)$  of Tesla

$$\begin{aligned} E(s) &= (.158 * v^2) / 23 = .0068695652 * (v^2) \quad v \text{ measured in mph} \\ &= .0068695652 * (v^2) * .44704 = .00307097 (v^2) \quad v \text{ measured in m/s} \end{aligned}$$

## Total Energy Required

The total energy equations dictate how much energy the bicycle system will need given the desired range and speed. The total energy use was calculated for two different speeds.

\*Assume 500  $m$  elevation change

\*Assume 10 start/stops

@ 25 mph

$$\begin{aligned} E(\text{max}) &= E(h) + E(s) + [E(a) + \#Start/Stops]L \\ &= [(.219)*500] + \{ [.0068695652 * (25^2)] + \{ .04827 (25^2) + 10 \} * 20 \text{ miles} \} \\ &= 917.16 \text{ Watt Hours} \end{aligned}$$

@ 20 mph

$$\begin{aligned} E(\text{max}) &= E(h) + E(s) + [E(a) + \#Start/Stops]L \\ &= [(.219)*500] + [.0068695652 * (20^2)] + \{ .04827 (20^2) + 10 \} * 20 \text{ miles} \\ &= 698.40 \text{ Watt Hours} \end{aligned}$$

### Length of Trip

The length of trip equations is just a reorganization of the total energy equation above.

$$L = [E(\text{max}) - E(\text{h}) - E(\text{s})] / [E(\text{a}) + \#\text{Start/Stops}]$$

### Watt Hours Per Mile

The equations below help determine how many watt hours will be used by the bicycle system per mile. The watt hours per mile required of the system was calculated for two different speeds.

@ 25 mph

$$\begin{aligned} Wh/M &= 917.16847 \text{ wh}/20 \text{ miles} \\ &= 45.85 \text{ Wh}/M \end{aligned}$$

@ 20 mph

$$\begin{aligned} Wh/M &= 698.407826 \text{ wh}/20 \text{ miles} \\ &= 34.92 \text{ Wh}/M \end{aligned}$$

### Time/Range

The Time/Range equations calculate how much time in total each of these systems could last. The calculations are broken down first by motor power then by speed.

#### \*Assuming 750 Watt Motor

@ 25 mph

$$\begin{aligned} \text{Energy} &= \text{Power} * \text{Time} \\ 917.16847 \text{ Watt Hours} &= 750 \text{ Watts} * \text{Time} \\ \text{Time} &= 1.22 \text{ Hours} \end{aligned}$$

@ 20 mph

$$\begin{aligned} \text{Energy} &= \text{Power} * \text{Time} \\ 698.407826 \text{ Watt Hours} &= 750 \text{ Watts} * \text{Time} \\ \text{Time} &= .93 \text{ Hours} \end{aligned}$$

#### \*Assuming 500 Watt Motor

@ 25 mph

$$\begin{aligned} \text{Energy} &= \text{Power} * \text{Time} \\ 917.16847 \text{ Watt Hours} &= 500 \text{ Watts} * \text{Time} \\ \text{Time} &= 1.83 \text{ Hours} \end{aligned}$$

@ 20 mph

$$\begin{aligned} \text{Energy} &= \text{Power} * \text{Time} \\ 698.407826 \text{ Watt Hours} &= 500 \text{ Watts} * \text{Time} \\ \text{Time} &= 1.39 \text{ Hours} \end{aligned}$$

### Extended Range

The extended range calculations were performed to see the impact assisted pedaling would have on the bicycle system. The calculations are broken down first by motor power then by speed.

\*Assume humans produce 100 watts when pedaling

#### \*Assuming 750 Watt Motor

@ 25 mph

$$\begin{aligned} \text{Energy} &= \text{Power} * \text{Time} \\ &= 100 \text{ watts} * 1.078293 \text{ Hours} \\ &= 107.82 \text{ watt hours} \end{aligned}$$

@ 20 mph

$$\begin{aligned} \text{Energy} &= \text{Power} * \text{Time} \\ &= 100 \text{ watts} * .78662 \text{ Hours} \\ &= 78.66 \text{ watt hours} \end{aligned}$$

$$\begin{aligned} \text{Total Energy} &= 107.8293 \text{ watt hours} \\ &+ 917.16847 \text{ watt hours} \\ &= 1024.99 \text{ watt hours} \end{aligned}$$

$$\begin{aligned} \text{Total Energy} &= 78.662 \text{ watt hours} \\ &+ 698.407826 \text{ watt hours} \\ &= 777.06 \text{ watt hours} \end{aligned}$$

$$\begin{aligned} \text{Watt Hours Per Mile} &= 1024.9977 \text{ watt hours} \\ &/ 20 \text{ miles} \\ &= 51.24 \text{ Wh/Mile} \end{aligned}$$

$$\begin{aligned} \text{Watt Hours Per Mile} &= 777.0698 \text{ watt hours} \\ &/ 20 \text{ miles} \\ &= 38.85 \text{ Wh/Mile} \end{aligned}$$

**\*Assuming 500 Watt Motor**

@ 25 mph

$$\begin{aligned} \text{Energy} &= \text{Power} * \text{Time} \\ &= 100 \text{ watts} * 1.61744 \text{ Hours} \\ &= 161.74 \text{ watt hours} \end{aligned}$$

@ 20 mph

$$\begin{aligned} \text{Energy} &= \text{Power} * \text{Time} \\ &= 100 \text{ watts} * 1.17993 \text{ Hours} \\ &= 117.99 \text{ watt hours} \end{aligned}$$

$$\begin{aligned} \text{Total Energy} &= 161.744 \text{ watt hours} \\ &+ 917.16847 \text{ watt hours} \\ &= 1078.91 \text{ watt hours} \end{aligned}$$

$$\begin{aligned} \text{Total Energy} &= 117.993 \text{ watt hours} \\ &+ 698.407826 \text{ Watt Hours} \\ &= 816.40 \text{ watt hours} \end{aligned}$$

$$\begin{aligned} \text{Watt Hours Per Mile} &= 1078.912 \text{ watt hours} \\ &/ 20 \text{ miles} \\ &= 53.94 \text{ Wh/Mile} \end{aligned}$$

$$\begin{aligned} \text{Watt Hours Per Mile} &= 816.4008 \text{ watt hours} \\ &/ 20 \text{ miles} \\ &= 40.82 \text{ Wh/Mile} \end{aligned}$$

### Regenerative Braking

The regenerative braking calculations were done to determine the efficacy of regenerative braking when applied to our system. The calculations are broken down by speed.

$$E(\text{recovered from braking}) = .5 * m * (v^2)$$

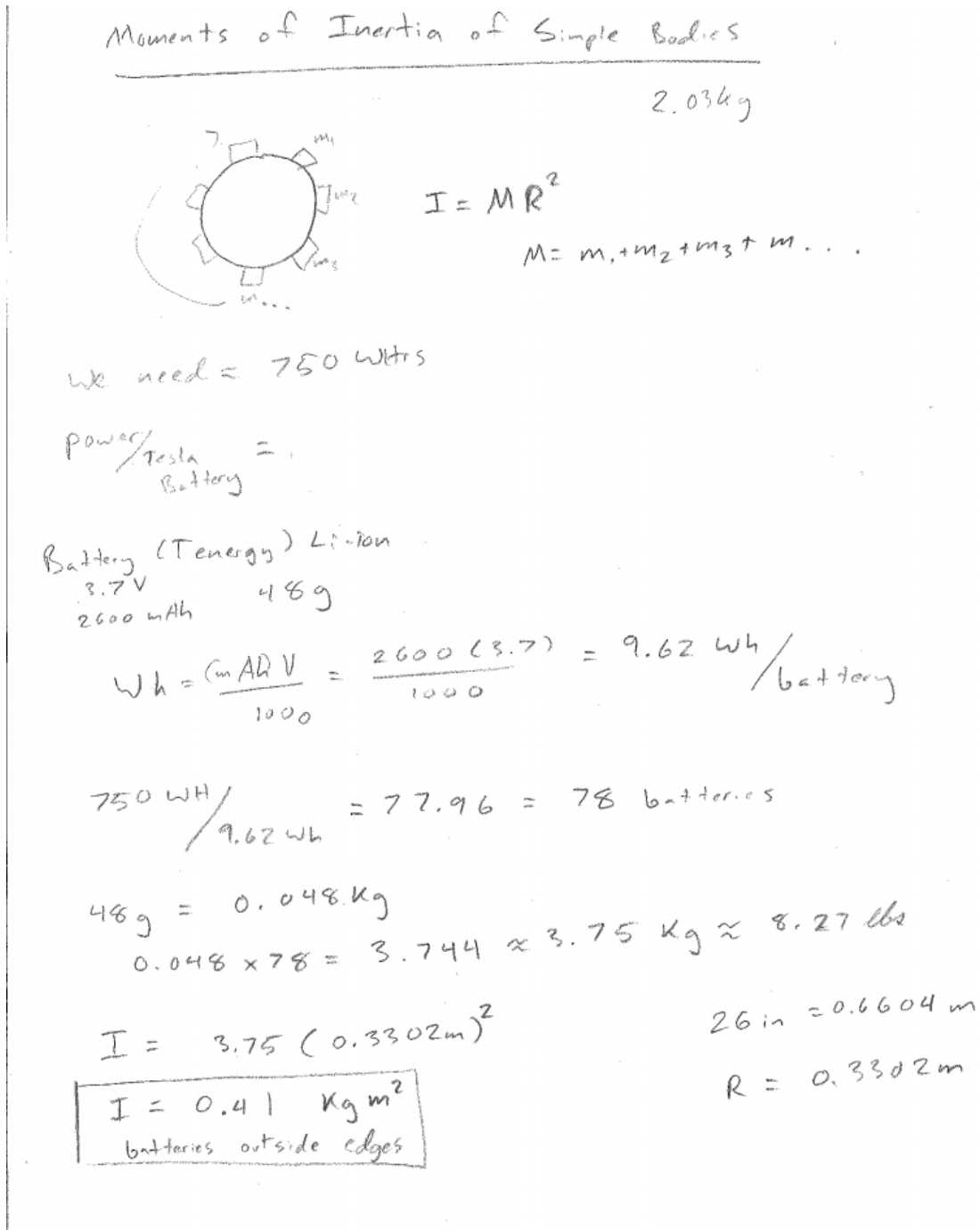
@ 25 mph

$$\begin{aligned} E(\text{recovered}) &= .5 * 107 \text{ kg} * ( 11.17 \text{ m/s} ^2) \\ E(\text{recovered}) &= 6,675.13 \text{ newtons} \end{aligned}$$

@ 20 mph

$$\begin{aligned} E(\text{recovered}) &= .5 * 107 \text{ kg} * ( 8.94 \text{ m/s} ^2) \\ E(\text{recovered}) &= 4, 275.9126 \text{ newtons} \end{aligned}$$

## Appendix E: Inertia Calculations



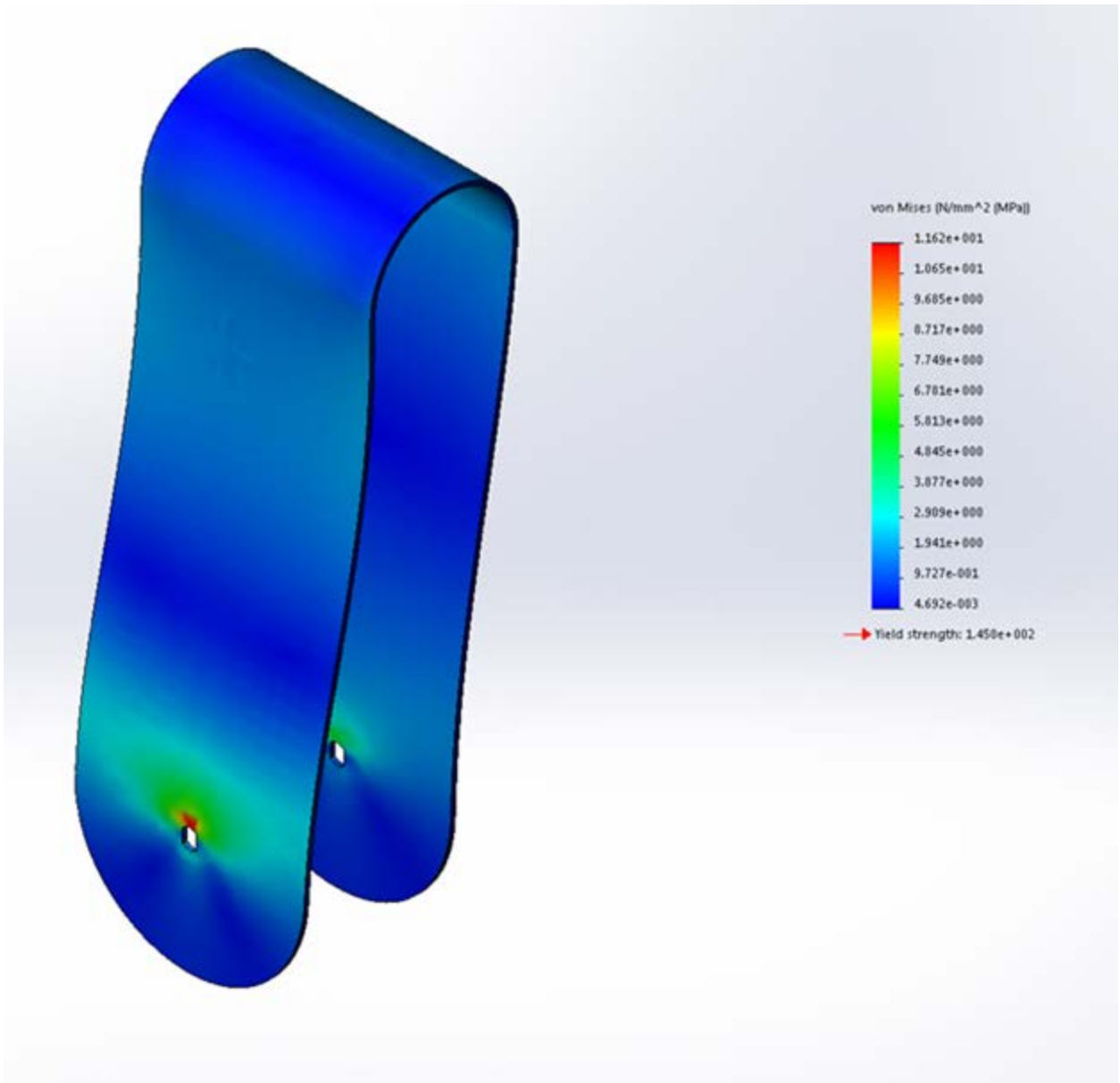
**Figure E-1: Inertia Calculations**

## **Appendix F: Finite Element Analysis**

### **Scenario 1: 80 km/h Crosswind**

**Description:** This model represents the structure experiencing an 80 km/h wind normal to its flat and wide surface. This wind speed was chosen because it is fairly severe; the system will probably not have to perform under such conditions, but this analysis allows for a factor of safety to be built in to the design.

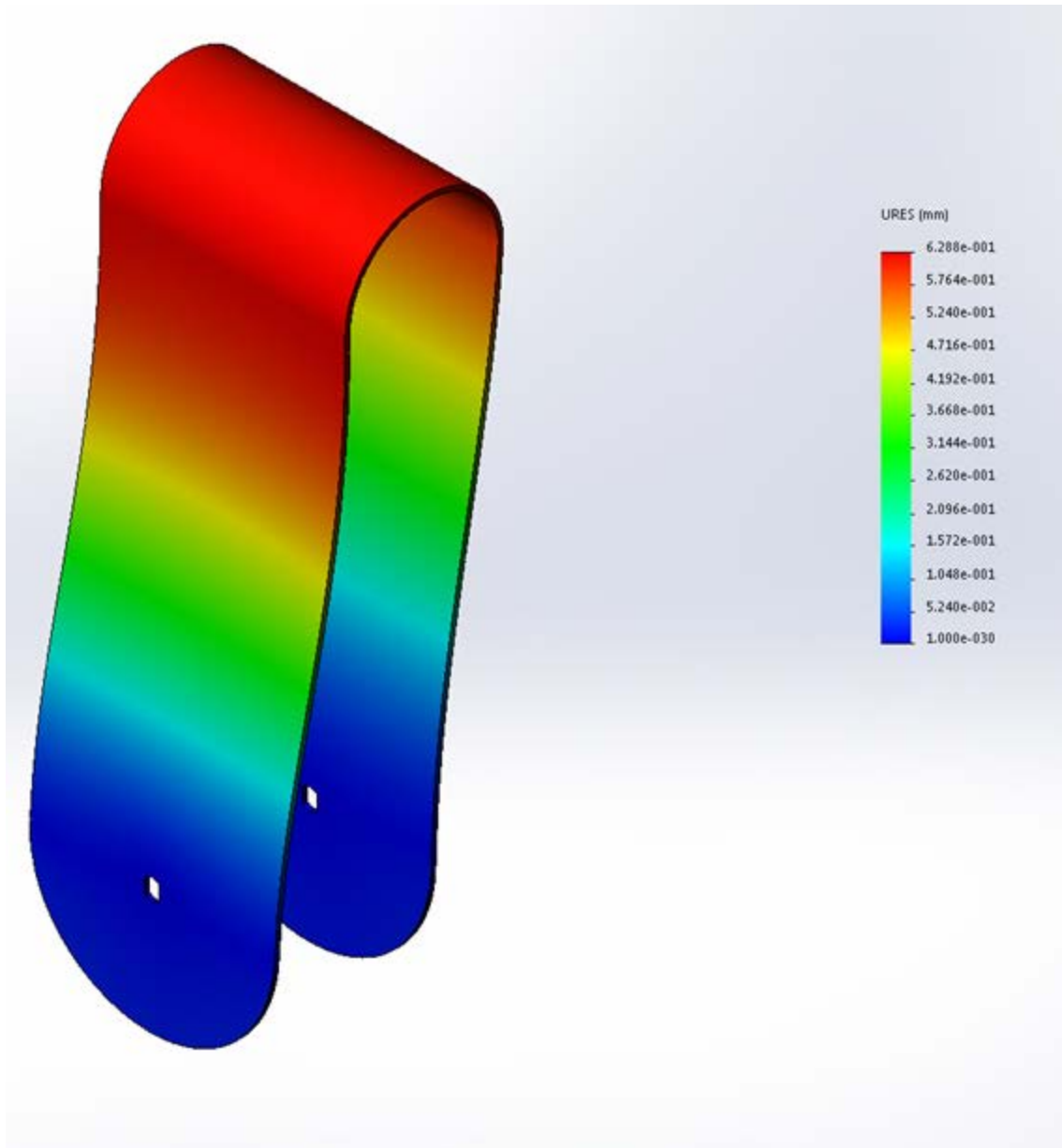
**External Loads:** The 80 km/h crosswind was converted into a 322 Pa pressure using a conversion table provided by Bristolite Daylighting Systems (Appendix G).



**Figure F-1:** The Von Mises Stresses Resulting from the 80 km/h Crosswind

**Modeling Results and Interpretation:** The maximum displacement that would occur from this cross wind would be 0.629 mm at the end farthest from the axle. This is a relatively small displacement and will not affect the functionality of the structure or result in any damage.

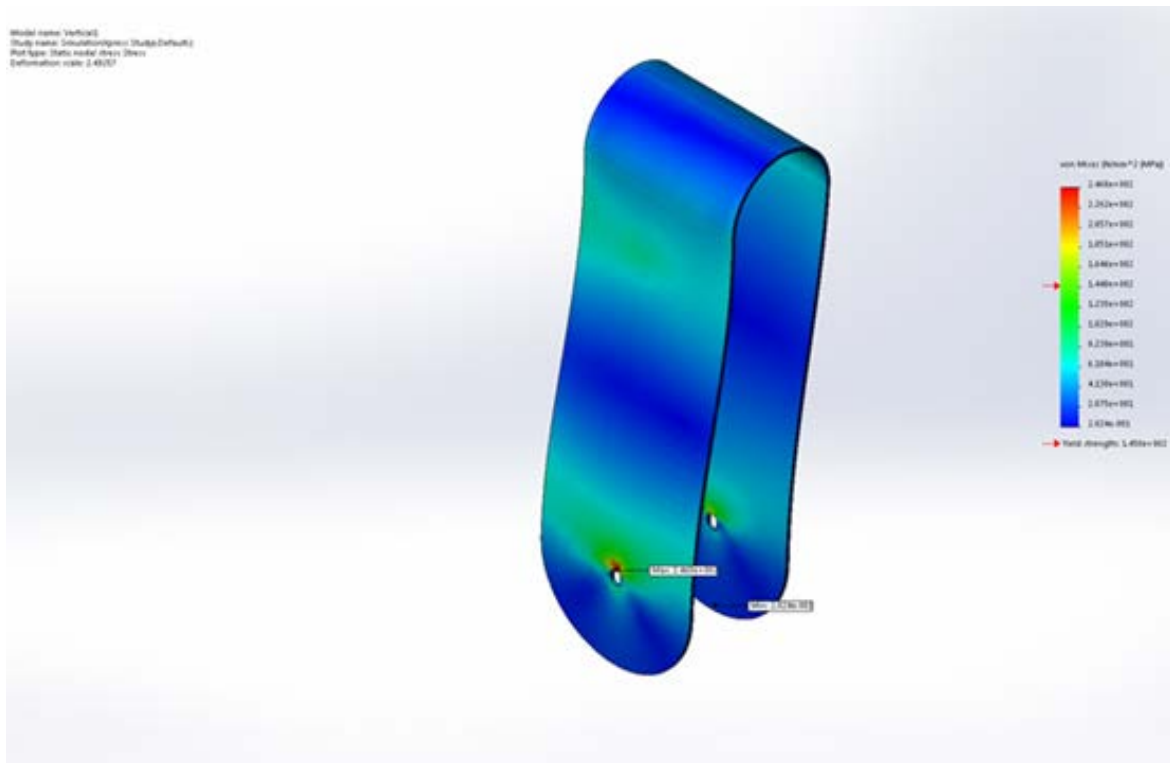




**Figure F-2:** The Deflection Resulting from the 80 km/h Crosswind

### Scenario 2: Point Impact to Side of Structure

**Description:** This model represents a point impact to the back of the structure. This was modeled in order to test the deflection if a rock were to fly up and hit the back of the structure or if someone were to kick the structure. This was modeled by placing a circle on the back side and applying a 270 N force to that circle (about the force from the kick of a professional soccer player).

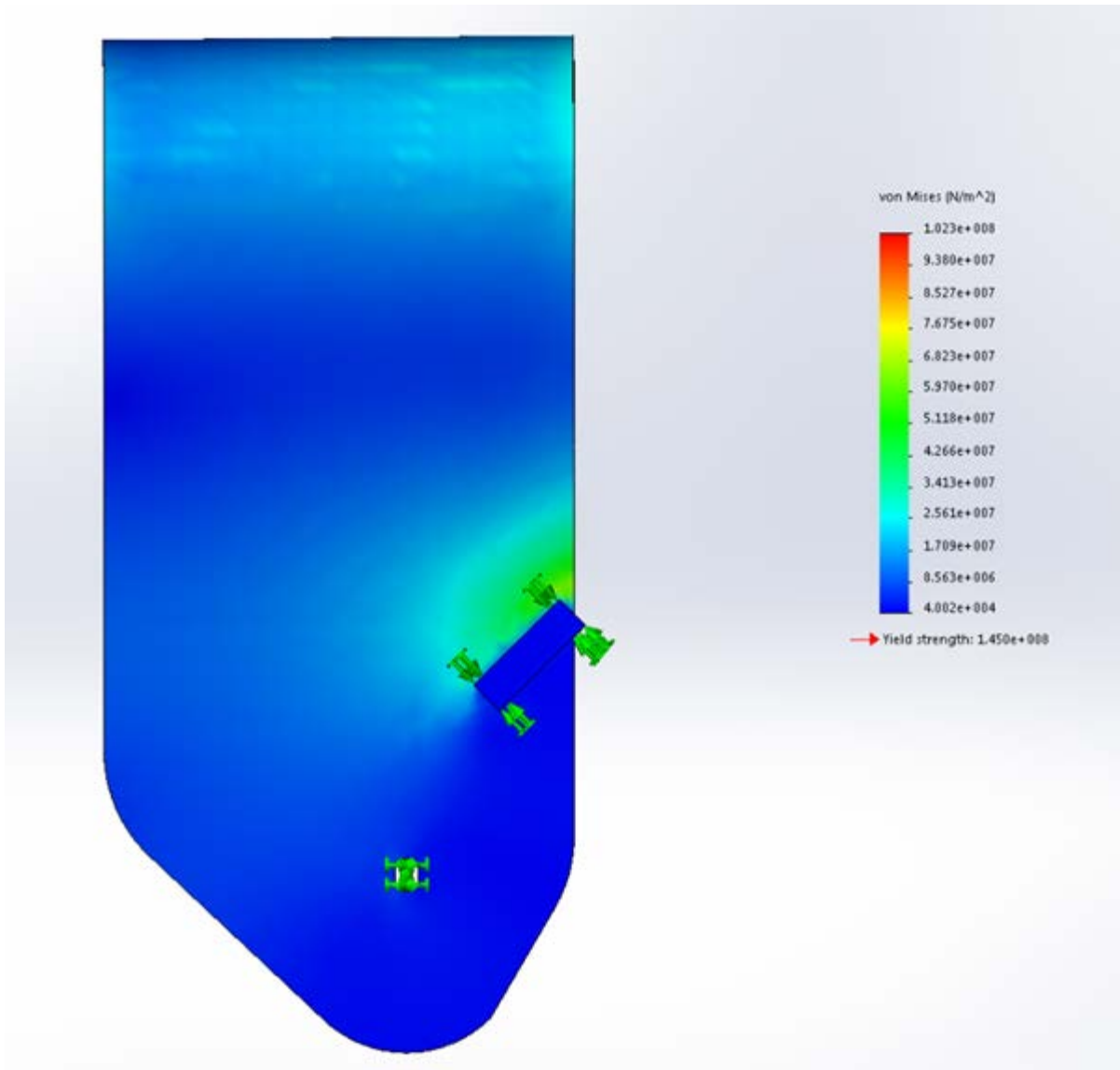


**Figure F-3:** The Deflection Resulting from the 270 N Point Force.

**Modeling Results and Interpretation:** The results showed that the maximum stress to occur will be  $2.46E8$  Pa at the axle. This stress will result in some of the metal around the axle deforming. Over time, this could result in less stability of the plate to the axle. Because the structure is only supported by the two attachments at the axle, it is important that they remain tight and secure. To maintain stability, further support is necessary. However, the force being tested is relatively high and the structure is not expected to take this kind of abuse. The model was tested with lower forces at the same point and was found to experience no yielding up to a force of about 170 N.

### **Scenario 3: Additional Support with Seat Stay Clamps with Point Impact**

**Description:** Identical to Scenario 2, however with additional support with the seat stay clamps



**Figure F-4:** The Von Mises Stresses Resulting from a 270N Impact Force

**Modeling Results and Interpretation:** With the additional supports the plates are able to withstand the force of a strong kick without any permanent deformation. With this design the operator can ensure he is safe while riding and the structure will not deform if subject to an impact force such as a crash or if the bicycle is dropped.

## Appendix G: Wind Speed to Pressure Conversion Chart

Pressure values were converted to SI for wind speed calculations.

**Table G-1:** Wind Speeds to Pressure Conversion [20]

P.S.F.	M.P.H.	P.S.F.	M.P.H.
0.10	6.25	22.50	93.75
0.30	10.83	25.00	98.82
0.57	14.92	25.60	100.00
1.57	24.76	27.50	103.64
1.60	25.00	30.00	108.25
2.00	27.95	32.50	112.67
2.86	33.42	35.00	116.93
3.00	34.23	37.50	121.03
3.50	36.98	40.00	125.00
3.75	38.27	42.50	128.85
4.00	39.53	45.00	132.58
4.50	41.93	47.50	136.22
5.20	45.07	50.00	139.75
6.00	48.41	55.00	146.58
6.24	49.37	60.00	153.09
6.40	50.00	65.00	159.34
7.70	54.84	70.00	165.36
8.00	55.90	75.00	171.16
9.20	59.95	80.00	176.78
10.00	62.50	85.00	182.22
10.80	64.95	90.00	187.50
12.00	68.47	95.00	192.64
12.50	69.88	100.00	197.64
15.00	76.55	105.00	202.52
17.50	82.68	110.00	207.29
20.00	88.39	115.00	211.95

## **Appendix H: Business Plan**

### **Introduction**

Bicycles are a popular form of transport, especially for commuting in urban areas. Electric bikes have been growing in popularity recently due to their ability to extend a cyclist's range, alleviate some of the workload, make for a consistent commute, and prevent sweating through one's work clothes. The electric bike market is comprised of two main groups: electric bikes and conversion kits. Electric bikes are sold as fully completed products that are ready to ride, and generally cost between \$1,500 for the lowest grade and around \$10,000 for the highest grade. Conversion kits are made to install on a user's previously owned bike, and generally require mechanical and electrical aptitude. Most, when factoring in the cost of batteries, cost around \$800-\$1,500. There is a wide variety of conversion kits that do not include batteries and require the user to purchase, connect, and mount them. Only two conversion kits (FlyKly and Copenhagen Wheel, both of which are in the pre-order stage right now) include batteries and wireless electronics packaged together to ease installation and improve the user's experience. Might-E Wheel aims to achieve this goal and enhance existing technologies and user experiences.

The current team (three mechanical engineers and one electrical engineer) would be able to take over the roles of CEO, CTO, senior manufacturing manager, and senior electrical engineer. In terms of additional personnel required, we would need a CFO, a marketing manager, an accountant, two salespeople (one for online distribution and one for vendor distribution), and two or three manufacturing engineers.

### **Goals and Objectives**

The goal of the Might-E Wheel enterprise is to promote sustainable travel by making commute by electric bicycle more approachable and accessible. With road congestion and traffic prices increasing and irreversible environmental changes partially due to automobiles, Might-E Wheel aims to be a catalyst in a transition to sustainable transportation.

Might-E Wheel seeks to appeal to the average consumer and intuitive for use by technical novices. Ideally, Might-E Wheel would initially be adopted by bicycle owners looking to commute farther and more comfortably. Might-E Wheel could also be implemented by existing city bike programs that operate on a leasing system.

### **Product Description**

Might-E Wheel is the first wireless rear-wheel replacement to convert bicycles from manual to full-power electric. With an intuitive and quick installation, users can convert their bicycles to full-power electric just by replacing their rear-wheel with Might-E Wheel and attaching the handlebar assembly, consisting of the thumb throttle and regenerative brake. Converting existing bicycles to electric will allow commuters to travel farther by bicycle, resulting in more consistent commute times, reduced emissions on roads, and a more enjoyable commute.

### **Potential Markets**

Electric bikes appeal to a wide variety of consumers and markets. The primary target audience would be urban commuters seeking to travel 24 km or less to work. This audience would want to buy the product due to its ease of installation and ability to transport them to their destination consistently and comfortably. Another target market is senior citizens. Many people above the age of 65 enjoy being outside and taking fun trips, however the majority are too weak to pedal a bike for long or up a hill. The product would enable them to have fun bike rides outdoors while not wearing on their body at all. A final target audience would be people charged with a DUI. These people generally have their license suspended for a period of time, yet need a proper form of transportation. Might-E Wheel would provide them with a solution that enables them to ride a bike for long distances to get them where they need to go.

### **Competition**

Might-E Wheel is competing for a similar market as the FlyKly Smart Wheel and the Superpedestrian Copenhagen Wheel. These products are both fully enclosed systems that encompass the motor, controls, and batteries within the hub of the wheel. Both FlyKly and Copenhagen Wheel entered the market through a crowdfunding campaign. FlyKly has

recently completed fulfillment, but Copenhagen Wheel is still in the pre-order stage. Both of these products only offer pedal assist where the motor amplifies the input of the user to the pedals and they are not equipped with fully electric capabilities. The specifications of FlyKly and Copenhagen Wheel are shown in Table 1.

**Table H-1:** The Important Specifications of Might-E Wheel and its Competitors

	<b>FlyKly</b>	<b>Copenhagen Wheel</b>	<b>Might-E Wheel</b>
<b>Price</b>	\$1,099	\$949	\$1,100
<b>Power Delivery</b>	Pedal Assist	Pedal Assist	Full Electric
<b>Interface</b>	Mobile App	Mobile App	Thumb Throttle
<b>Top Speed (km/h)</b>	25	25	27
<b>Range (km)</b>	40	50	24 (predicted)
<b>Power (W)</b>	250	350	311
<b>Weight (kg)</b>	3	5.9	11.3

It is important to take into account the combination of human and electric power when comparing the range of the different products. Because the other two products are powered by pedal assist, the range is not only a result of battery power, but the power applied by the user. Might-E Wheel’s range is based on fully electric power only, and no additional human power.

The weight of Might-E Wheel in its current state is higher than its competitors, but this is a factor that the team is attempting to reduce in further development before market mobilization.

## **Sales and Marketing Strategies**

Might-E Wheel plans to enter the market through a crowdfunding campaign. The campaign will allow customers to place pre-orders through the Might-E Wheel website. A transparent fulfillment date will be given upon ordering to prevent frustrated customers. Beginning sales in a pre-order stage will allow Might-E Wheel to test market interest while acquiring funds for manufacturing and initial business costs. The company can also continue to develop and improve on the technology in order to deliver the best possible product to the customer.

Might-E Wheel will work with press to gain publicity and awareness going into the crowdfunding campaign. The company will also make a vision video in order to share the possible uses of the product with consumers.

From there, Might-E Wheel will work with e-commerce sites to minimize costs of sales and distribution in the early phases. Many of these websites sell “cool” tech products, and Might-E Wheel will likely appeal to these consumers.

Once an initial market has been established and brand awareness has developed, Might-E Wheel will move into bicycle stores. With Might-E Wheel, consumers can buy a manual bike and use it for its traditional purposes, as well as for electric transportation when necessary.

## **Manufacturing Plans**

Might-E Wheel is comprised of multiple aluminum pieces that are easily manufactured. To achieve the volume and price that is needed, the separate pieces will be cut by outsourcing to a local CNC machine shop. This shop will be able to provide accurate cutting and be able to replicate each part in volume. Once the parts are cut by the shop, all of the pieces will be assembled by the manufacturing engineers and overseen by the senior engineer to ensure a safe and consistent product. Each Might-E Wheel will take approximately five hours to cut all the necessary pieces and another two hours to assemble each package.

Included in the Might-E Wheel package is a thumb throttle and regenerative braking assembly that will need to be manufactured. For this specific piece it will be a molded casing, which the thumb control will install into. This molded piece will be outsourced to a



manufacturing company in China, which will be able to deliver an affordable product. The case and assembly will take approximately four hours each to mold, trim, and assembly into a usable product. To begin molding these parts, an estimated \$4,000 will be needed to cut the mold and to start the manufacturing process.

To ensure that the Might-E Wheel will be readily available to the public, at least 100 Might-E Wheel assemblies will be in inventory at a time. This is due to the manufacturing time needed to cut the needed pieces, the time it takes to assemble each unit, and testing time to ensure a safe and reliable product. This will allow for any issues to be solved in future batches and initial shipments to go out in waves to the earliest backers.

To expand Might-E Wheel, a facility will be purchased to be able to house a CNC machine where the Might-E Wheel's respective pieces will be manufactured in house. This would cut the cost of outsourcing the machining work and reducing the turnover time per unit.

### **Product Cost and Price**

The company's costs can be broken down into fixed costs and per-unit costs. Each unit is estimated to cost \$770 to manufacture, and would be sold at a price of \$1,110 (compared to FlyKly's price of \$1,099 and Copenhagen Wheel's price of \$949). This creates a base profit of \$340 per unit. The initial manufacturing plans are to create 1,000 units to test the market, resulting in a base profit of \$340,000. Based on the success of this run, production could be increased up to 5,000 units per year, resulting in a base profit of \$1.7 million per year, assuming facilities costs of \$50,000 per year and personnel costs (salaries) totaling \$700,000 that is divided up between the estimated 12 employees of the company. Other fixed costs would include marketing, sales, R&D, employee benefits, and manufacturing costs. These costs would divide up among the remaining \$950,000 of the money earned.

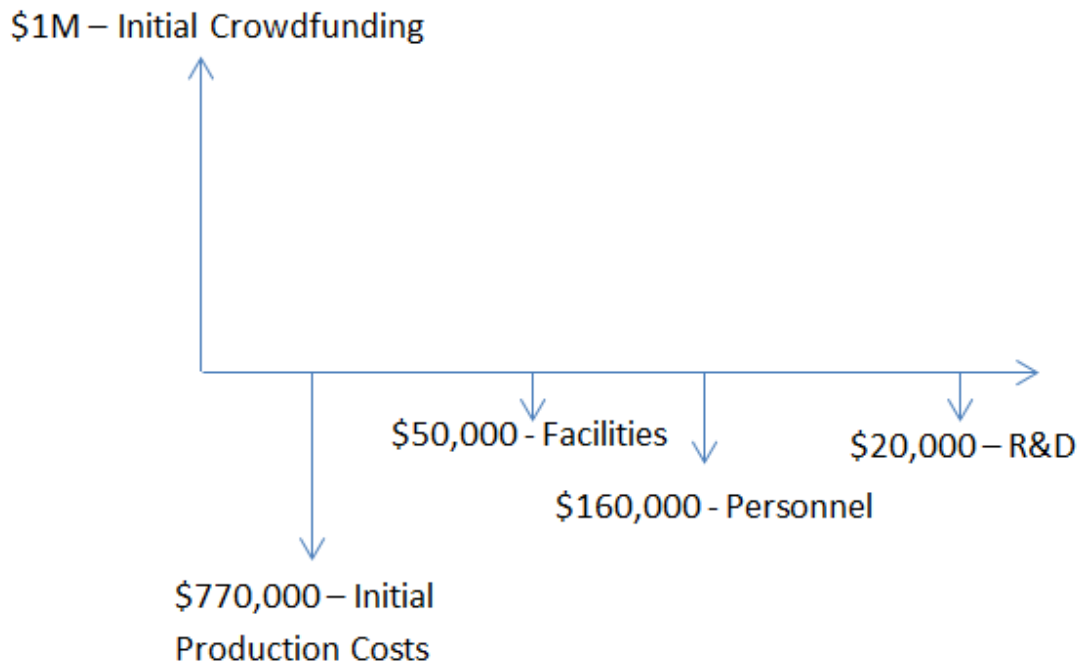
### **Warranty**

Might-E Wheel will offer a 1 year limited warranty from the date of fulfillment on any hardware defects not due to accidental damage or normal wear and tear. Should any issues

arise during the warranty period and the claim is valid, Might-E Wheel will either repair the defect or replace the affected parts.

### Financial Plan

All money for the initial production run of 1,000 units would be raised through a crowdfunding campaign (see Sales and Marketing). The initial production costs are \$770,000 (\$770 per unit for 1,000 units). The initial crowdfunding goal is \$1 million; this would pay for the production costs as well as facilities costs, and the remaining money would be invested into employees and further R&D. Figure 1 shows the initial cash flow for the first year of business.



**Figure H-1:** Cash Flow Analysis for the First Year of Might-E Wheel

## Appendix I: Artistic Contributions

**Table I-1:** The Artistic Contributions Made by each Team Member.

<b>Team Member</b>	<b>Description</b>	<b>Location</b>
Abby Grills	CAD Full Assembly	Figure J-2
	Battery Structure CAD Drawing	Figure J-5
Daniel Doke	Theoretical Custom Motor Design	Figure 3-8
	Exploded Assembly CAD Drawing	Figure J-1
	Top Structure CAD Drawing	Figure J-4
Zach Jesberger	Battery Support CAD Drawing	Figure J-3
	Seat Stay Clamp CAD Drawing	Figure J-6
Jared O'Rourke	Functional Decomposition	Figure 2-1
	System-Level Design with Subsystems Layout	Figure 2-2

# Appendix J: Mechanical Drawings

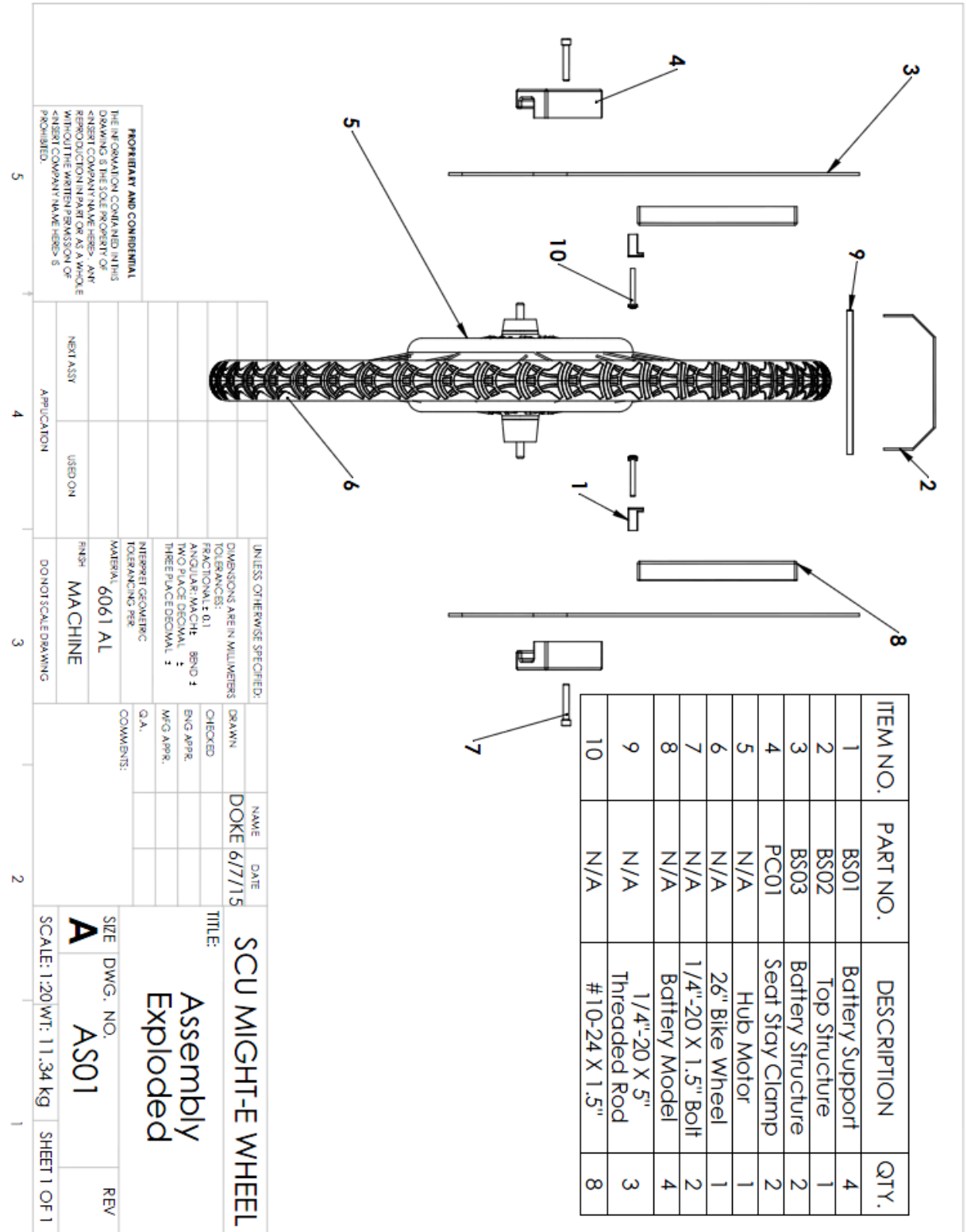
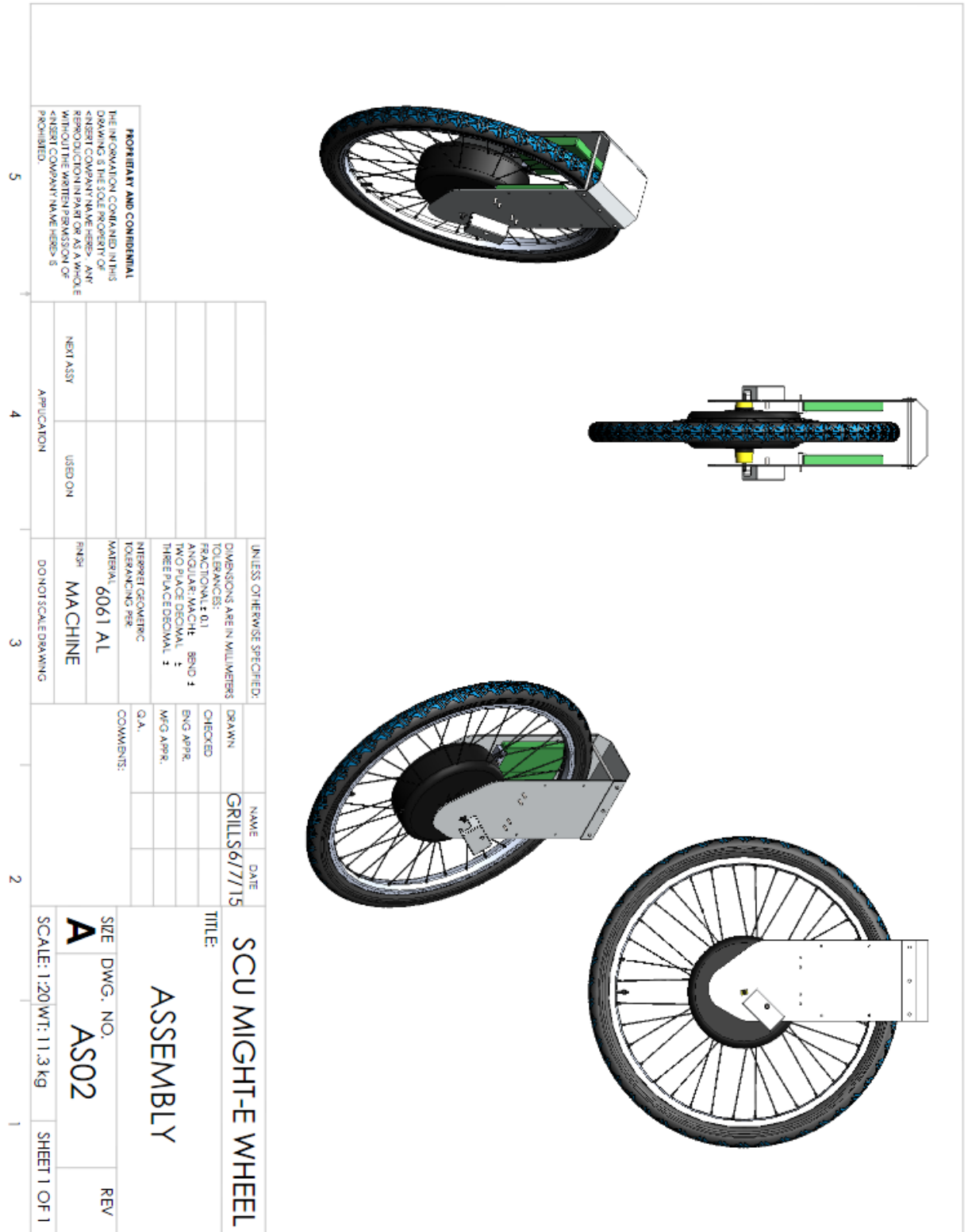


Figure J-1: Exploded Assembly Drawing and Bill of Materials



**Figure J-2: Full Assembly**

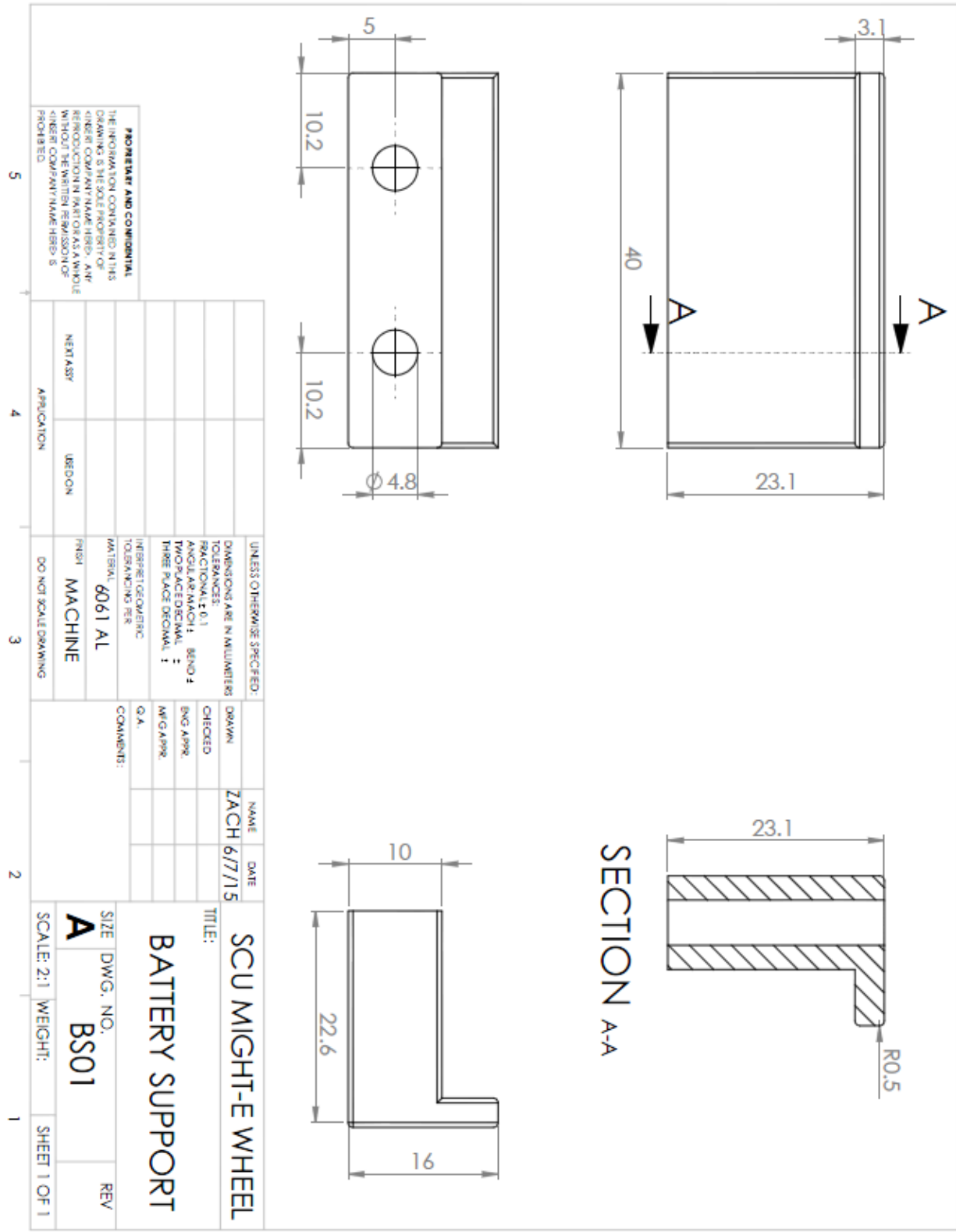
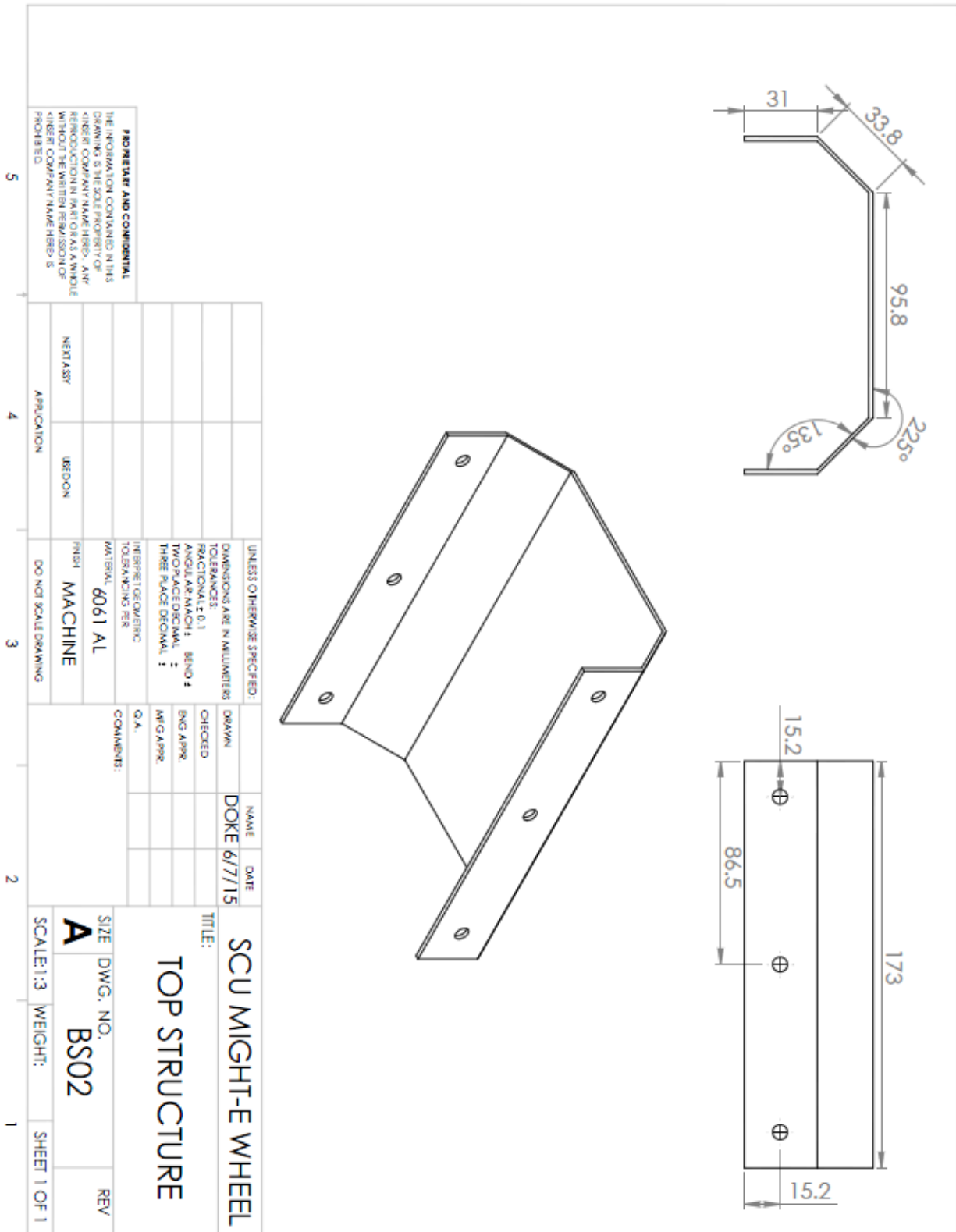


Figure J-3: Battery Support Drawing



**Figure J-4:** Top Structure Drawing





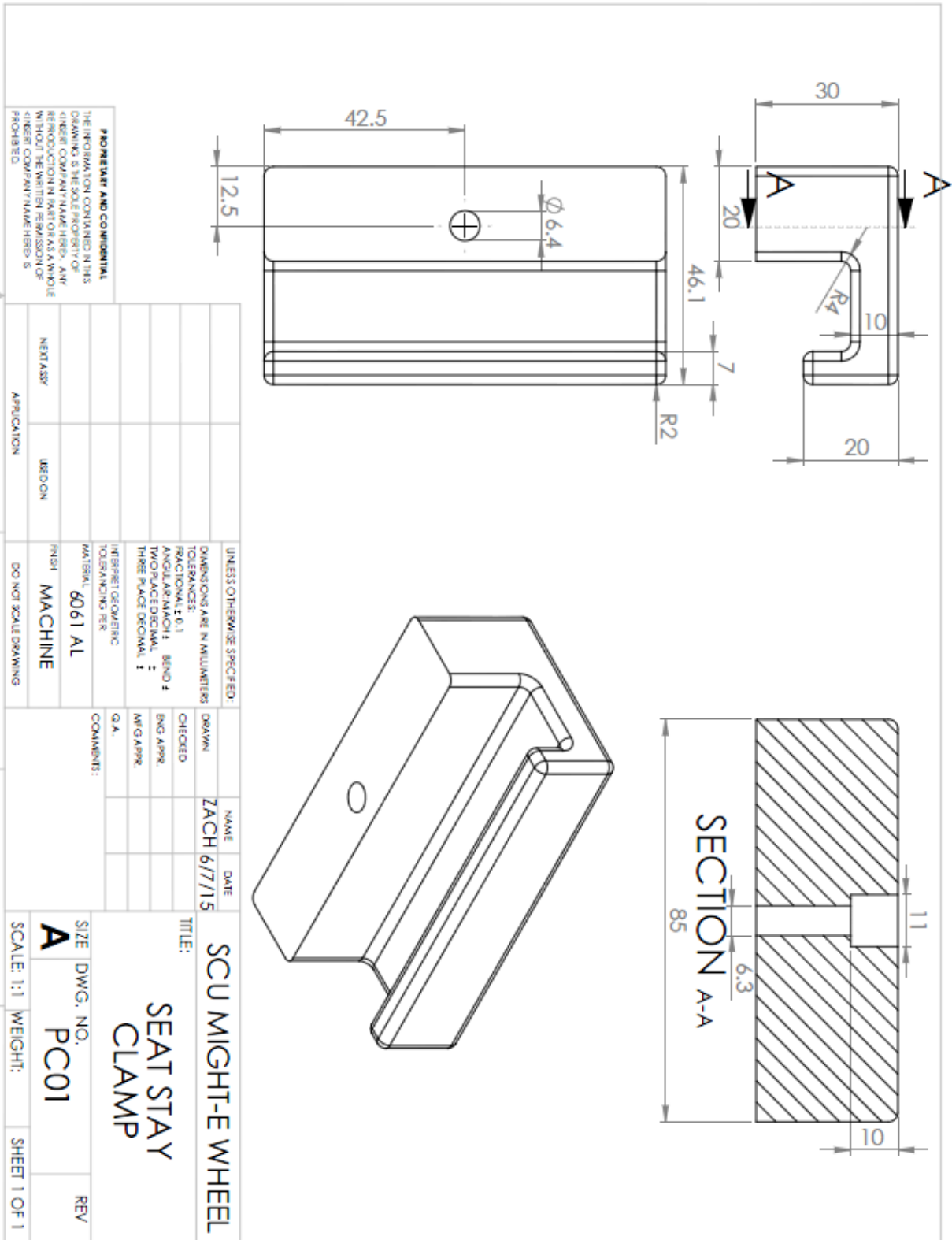


Figure J-6: Seat Stay Clamp Drawing