

1994

Effective, Reliable, Inexpensive Cryofixation Device

Lawrence A. Mink
Arkansas State University

Roger A. Buchanan
Arkansas State University

Follow this and additional works at: <http://scholarworks.uark.edu/jaas>

 Part of the [Biochemistry Commons](#), [Organic Chemistry Commons](#), and the [Physical Chemistry Commons](#)

Recommended Citation

Mink, Lawrence A. and Buchanan, Roger A. (1994) "Effective, Reliable, Inexpensive Cryofixation Device," *Journal of the Arkansas Academy of Science*: Vol. 48 , Article 55.

Available at: <http://scholarworks.uark.edu/jaas/vol48/iss1/55>

This article is available for use under the Creative Commons license: Attribution-NoDerivatives 4.0 International (CC BY-ND 4.0). Users are able to read, download, copy, print, distribute, search, link to the full texts of these articles, or use them for any other lawful purpose, without asking prior permission from the publisher or the author.

This General Note is brought to you for free and open access by ScholarWorks@UARK. It has been accepted for inclusion in Journal of the Arkansas Academy of Science by an authorized editor of ScholarWorks@UARK. For more information, please contact scholar@uark.edu.

An Effective, Reliable, Inexpensive Cryofixation Device

Lawrence A. Mink and Roger A. Buchanan
 Department of Chemistry, Biochemistry and Physics
 and Department of Biological Sciences
 Arkansas State University
 State University, AR 72401

Cryofixation provides a unique method for the preparation of biological specimens that does not introduce the artifacts (chemical substitution, and significant dimensional changes) associated with standard chemical fixation procedures (see Kellenberger et al., 1987). Cryofixation, because of millisecond cooling, produces amorphous (or microcrystalline) ice so that morphological characteristics and elemental location are not modified by ice crystal formation (Van Harreveld and Crowell, 1964; Heuser et al., 1976; Angell and Choi, 1986). Ultrathin cryosections can then be cut from frozen tissue samples and transferred to a liquid nitrogen-cooled cold stage. Elemental analysis of subcellular compartments in these tissue sections can be completed using X-ray microanalysis or electron energy loss spectroscopy in an appropriately configured analytical electron microscope (Buchanan et al., 1993; Leapman et al., 1993). Alternatively, frozen tissue can be prepared by freeze drying or freeze substitution for more conventional transmission or scanning electron microscopy (Buchanan et al., 1988; Landis and Reese, 1983).

We will describe the design, construction, and operation of a cryofixation device that can be produced on a limited budget. Similar commercially produced cryofixation devices are available for approximately \$30,000 [one device is available from RMC, Inc. of Tucson, AZ]. We have constructed a very satisfactory similar device in our laboratory for < \$4,000, including over \$1,000 for the mechanical vacuum pump. We utilized readily available quick-connect vacuum components and a limited amount of machining and welding of the type that is locally available at any machine shop.

Our device (Fig. 1), like some other laboratory and commercial cryofixation devices, consists of a LN₂ (Liquid Nitrogen) cooled cold finger maintained in a vacuum (<10 mTorr). This reduces LN₂ usage and prevents condensation on specimen cooling surface at the cold finger end. Dry pressurized N₂ is used to operate pneumatic valves and cylinders of our device and is introduced to break the vacuum. Electrically operated valves control the N₂ flow.

Commercially available quick-connect vacuum components were used to construct the vacuum chamber. These components include a 6-way quick-connect "T" (ISO #NW40, US 1.5" Series, available from MDC Vacuum Products of Hayward, CA), thermocouple and electrical

feed quick-connects, and Al quick-connect blanks that were tapped to accept vacuum gauge, N₂ inlet, cold finger and shutter pneumatic shaft. One of the O-ring metal spacer assemblies was ground flat on one side so that the shutter could slide perpendicular to the "T". The aluminum supporting structure was welded from plate. The copper cold finger was turned on a lathe from electrical purity Cu rod stock (standard 1-1/8" (2.86cm) OD stock). This cold-finger was also bored for the LN₂, tapped for the cooling surface on one end and on the other end for the LN₂ inlet and outlet connections. The replaceable cooling surfaces can be constructed on the lathe from the same (or smaller) Cu rod. Several of the Cu cooling surfaces may then be mounted in tapped holes on a piece of standard 1 by 1" (2.54 by 2.54 cm) steel stock and cheaply ground flat at a local machine shop. Simple power buffing may be used to produce a highly polished cooling surface. These replaceable cooling surfaces can be protected from chemical etching by Au or Pt plating, as are the commercially prepared varieties (RMC, Inc.).

During operation, (Fig. 1), the vacuum-surrounded cold finger cooling surface is first cooled by LN₂ flowing into and out of the cold finger. When the freezing surface is sufficiently cooled (thermocouple attached near the cooling surface), the specimen, after being placed on an aluminum planchet, is affixed using two-sided tape to a foam rubber cube that is then attached to the vertical pneumatic driver rod. The horizontal pneumatically-actuated shutter is then opened in conjunction with the introduction of dry N₂ via an electric valve to break the vacuum. This exposes the cooling surface that is located just above the shutter inside the vacuum chamber. Immediately, the vertical pneumatic cylinder is activated to drive the specimen against the cold surface where it freezes in milliseconds. The pneumatic pressure maintains good thermal contact between the specimen and the cooling surface and prevents bouncing. The foam cube absorbs some of the shock and prevents specimen compression. After freezing, the cryofrozen specimen is grasped with LN₂ cooled tweezers and rapidly transferred to a LN₂ holding container. The shutter is then re-closed (the re-opened vacuum quickly pulls the shutter leak-tight) to limit condensation on the freezing surface.

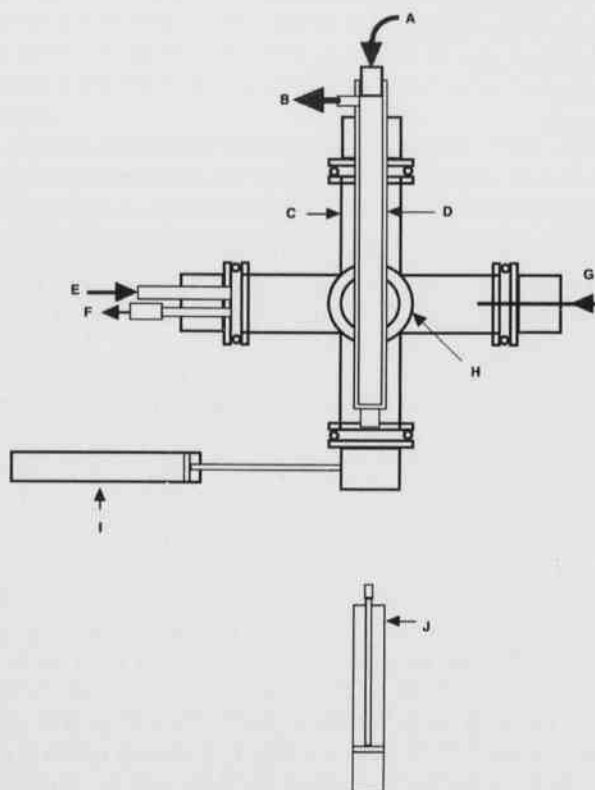

Fig. 1. Arrangement of parts of Cryogenic Fixation Device on a vertical Aluminum plate. Parts: A: LN₂ inlet; B: N₂ & LN₂ outlet; C: 6-way vacuum quick-connect "T"; D: Hollow Copper Cold finger with attached freezing surface; E: Dry N₂ inlet; F: Vacuum gauge; G: Heater-tape power connections; H: fifth (back) and sixth (front) ports for vacuum and thermocouple, respectively; I: Pneumatic cylinder to open/close shutter; J: Pneumatic cylinder that drives specimen onto freezing surface.

Accumulated ice on the freezing surface is removed by a vacuum-heating cycle: restore vacuum, stop LN₂ flow, heat cold finger end and cooling surface with an electric heat tape while pumping the vacuum. The LN₂ flow is then re-established to re-cool the cold finger and attached cooling surface in preparation for the next specimen.

We expect our cryofixation device to serve many investigators at ASU. We experienced only minor construction problems. First, finding U-bolts and constructing supports to attach and "T" to the Al frame took longer than expected. Second, positioning of the shutter pneumatic cylinder and the specimen pneumatic cylinder was by eye, not by pre-measure! Third, the length of the Cu cold finger was a trial and adjust procedure. Fourth,

the cold hardened the O-ring seal closest to the cold finger causing it to leak. As a result, we redesigned the Al blank holding the cold finger for maximum thermal resistance and may add a heat tape at the troublesome joint. Finally, should we construct another cryofixation device from scratch, we would use a larger diameter vacuum "T" and a thicker Al frame.

We would caution all who are considering constructing similar devices that the electro-pneumatic controls should be designed to require two-handed operation because the pneumatic cylinders exert sufficient force to maim careless fingers!

Acknowledgements

Partial funding for this project was provided by ASU and by ASTA grant # 94-B-03.

Literature Cited

- Angell, C.A. and Y. Choi. 1986. Crystallization and vitrification in the aqueous system. *J. Microsc.* 141:251-260.
- Buchanan, R.A., R.C. Wagner, S.B. Andrews and J. Frøjkaer-Jensen. 1988. Effect of section thickness on the morphological characterization of the vesicular system. *Microvasc. Res.* 35:191-196.
- Buchanan, R.A., R.D. Leapman, M.F. O'Connell, T.S. Reese and S.B. Andrews. 1993. Biological applications of the field-emission STEM: subcellular structure and analysis in ultrathin tissue cryosections. *J. Struct. Biol.* 110(3):244-255.
- Heuser, J.E., T.S. Reese and D.M.D. Landis. 1976. Preservation of synaptic structure by rapid freezing. *Cold Spring Harbor Symp. Quant. Biol.* 15:17-24.
- Kellenberger, E., E. Carlmalin and W. Villiger. 1987. Physics of the preparation and observation of specimens that involve cryoprotocols. *In: The science of biological specimen preparation for microscopy and microanalysis.* (M. Müller, R.P. Becker, A. Boyde and J.J. Woloszewick, Eds.,) Scanning Electron Microscope, Inc., O'Hare, IL. pp 1-20.
- Landis, D.M.D. and T.S. Reese. 1983. Cytoplasmic organization in cerebellar dendritic spines. *J. Cell Biol.* 97:1169-1178.
- Leapman, R.D., J.A. Hunt, R.A. Buchanan and S.B. Andrews. 1993. Measurement of low calcium concentrations in cryosectioned cells by parallel-EELS mapping. *Ultramicrosc.* 49:225-234.
- Van Harreveld and J. Crowell. 1964. Electron microscopy after rapid freezing on a metal surface and substitution fixation. *Anat. Res.* 149:381-386.