

## University of Arkansas, Fayetteville ScholarWorks@UARK

---

### Patents Granted

---

12-23-2008

# Microfluidic device utilizing magnetohydrodynamics and method for fabrication thereof

Eyitayo S. O. Fakunle

Prabhu U. Arumugam

Ingrid Fritsch

*University of Arkansas, Fayetteville*

Jeffrey Elbert Mincy

*University of Arkansas, Fayetteville*

Fred D. Barlow III

*University of Arkansas, Fayetteville*

*See next page for additional authors*

Follow this and additional works at: <http://scholarworks.uark.edu/pat>

---

### Recommended Citation

Fakunle, Eyitayo S. O.; Arumugam, Prabhu U.; Fritsch, Ingrid; Mincy, Jeffrey Elbert; Barlow, Fred D. III; and Wang, Gangqiang, "Microfluidic device utilizing magnetohydrodynamics and method for fabrication thereof" (2008). *Patents Granted*. Paper 93.  
<http://scholarworks.uark.edu/pat/93>

This Patent is brought to you for free and open access by ScholarWorks@UARK. It has been accepted for inclusion in Patents Granted by an authorized administrator of ScholarWorks@UARK. For more information, please contact [scholar@uark.edu](mailto:scholar@uark.edu).

---

**Inventors**

Eyitayo S. O. Fakunle, Prabhu U. Arumugam, Ingrid Fritsch, Jeffrey Elbert Mincy, Fred D. Barlow III, and Gangqiang Wang



US007467928B2

(12) **United States Patent**  
**Fakunle et al.**

(10) **Patent No.:** **US 7,467,928 B2**  
(45) **Date of Patent:** **Dec. 23, 2008**

(54) **MICROFLUIDIC DEVICE UTILIZING  
MAGNETOHYDRODYNAMICS AND  
METHOD FOR FABRICATION THEREOF**

(56) **References Cited**

U.S. PATENT DOCUMENTS

(75) Inventors: **Eyitayo S. O. Fakunle**, San Diego, CA (US); **Prabhu U Arumugam**, Sunnyvale, CA (US); **Ingrid Fritsch**, Fayetteville, AR (US); **Jeffrey Elbert Mincy**, Fayetteville, AR (US); **Fred D. Barlow, III**, Moscow, ID (US); **Gangqiang Wang**, Fayetteville, AR (US)

5,893,954	A *	4/1999	Nanataki et al. ....	156/89.11
5,897,723	A *	4/1999	Tatumoto et al. ....	156/89.11
5,985,119	A *	11/1999	Zanzucchi et al. ....	204/450
5,997,671	A *	12/1999	Takeuchi et al. ....	156/89.11
6,120,708	A *	9/2000	Ohshita et al. ....	252/511
6,171,420	B1 *	1/2001	Takahashi et al. ....	156/89.11
6,572,830	B1 *	6/2003	Burdon et al. ....	422/186.29
6,875,402	B2 *	4/2005	Hirota et al. ....	422/100
7,160,512	B2 *	1/2007	Hirota et al. ....	422/100
2002/0026978	A1 *	3/2002	Harada et al. ....	156/89.11
2003/0235504	A1 *	12/2003	Lemoff et al. ....	417/50
2005/0051253	A1 *	3/2005	Tosa et al. ....	156/89.11
2005/0194084	A1 *	9/2005	Yoshida et al. ....	156/89.11
2006/0096693	A1 *	5/2006	Murosawa et al. ....	156/89.12
2006/0130956	A1 *	6/2006	White et al. ....	156/89.11
2006/0213602	A1 *	9/2006	Yoshida et al. ....	156/89.12
2007/0214865	A1 *	9/2007	Nakae et al. ....	73/19.01

(73) Assignee: **Board of Trustees of the University of Arkansas**, Little Rock, AR (US)

(\* ) Notice: Subject to any disclaimer, the term of this patent is extended or adjusted under 35 U.S.C. 154(b) by 106 days.

(21) Appl. No.: **11/609,236**

(22) Filed: **Dec. 11, 2006**

(65) **Prior Publication Data**  
US 2007/0086898 A1 Apr. 19, 2007

**Related U.S. Application Data**

(62) Division of application No. 10/317,777, filed on Dec. 12, 2002, now Pat. No. 7,147,441.

(51) **Int. Cl.**  
**F04B 37/02** (2006.01)

(52) **U.S. Cl.** ..... **417/48**; 417/53; 422/100; 156/89.11

(58) **Field of Classification Search** ..... 417/44, 417/45, 48-50, 53; 422/100; 156/89.11  
See application file for complete search history.

\* cited by examiner

*Primary Examiner*—William H Rodriguez  
(74) *Attorney, Agent, or Firm*—Head, Johnson & Kachigian, P.C.

(57) **ABSTRACT**

Microfluidic channels utilizing magnetohydrodynamics are used to pump very small volumes of solution. The channels have electrodes along the walls and a current carrying species within a solution carries current through the solution. The combination of the electric and magnetic fields causes the solution to flow through the channel.

**39 Claims, 13 Drawing Sheets**

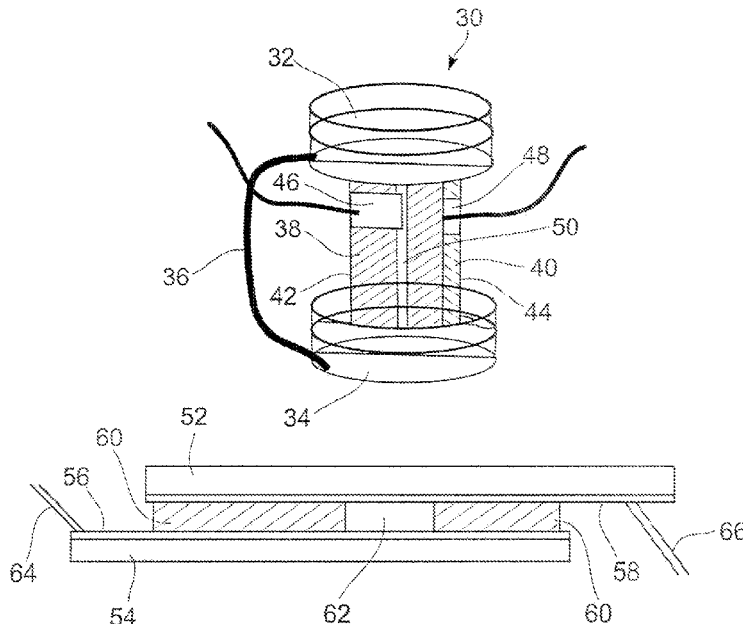

FIG. 1

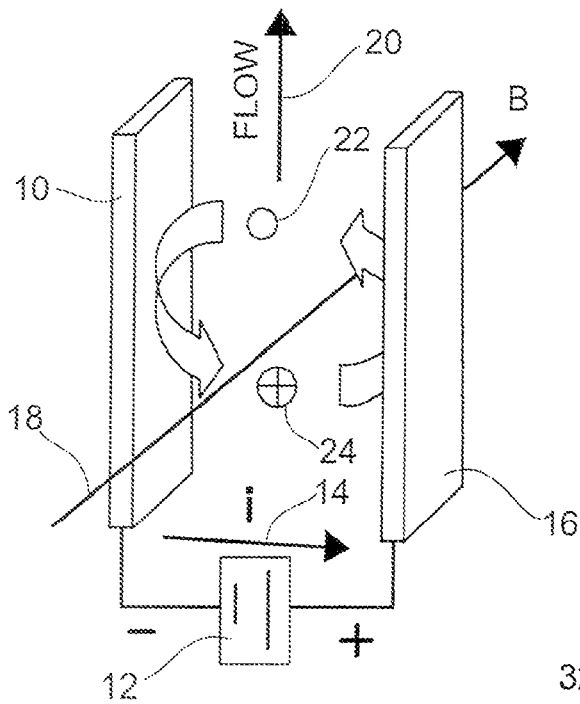

FIG. 2

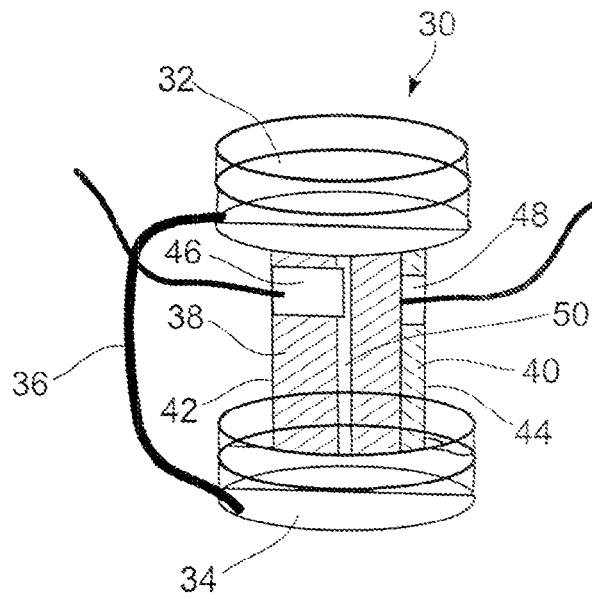

FIG. 3

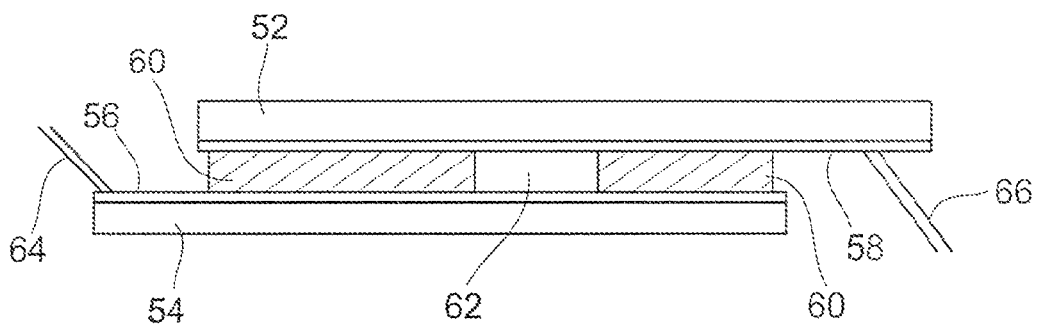

FIG. 4A

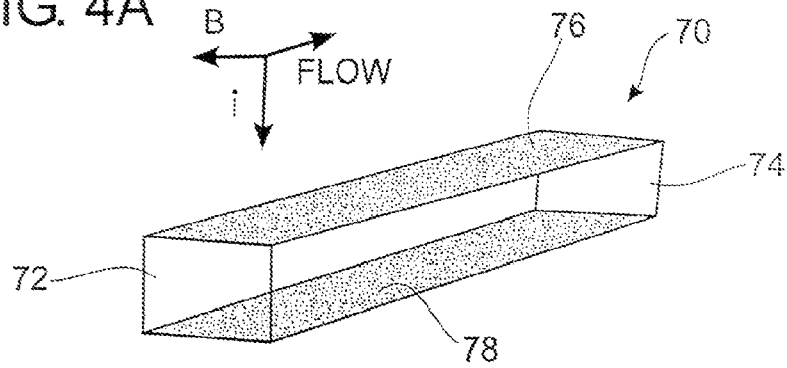

FIG. 4B

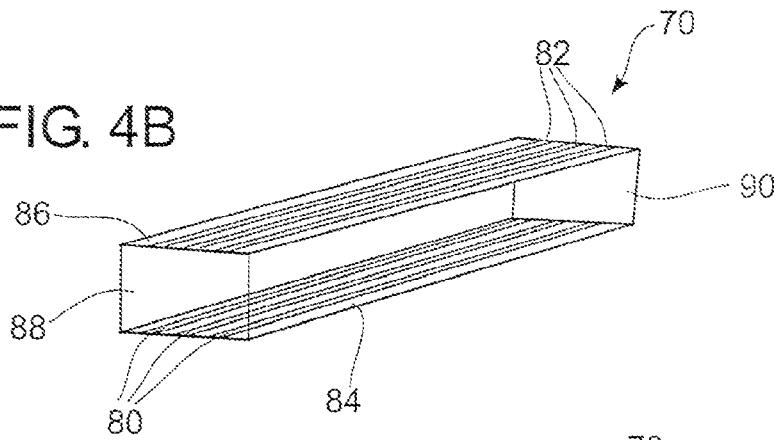

FIG. 4C

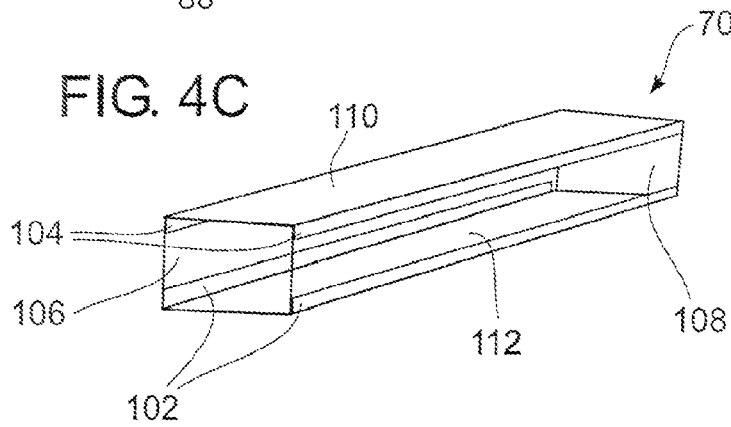

FIG. 4D

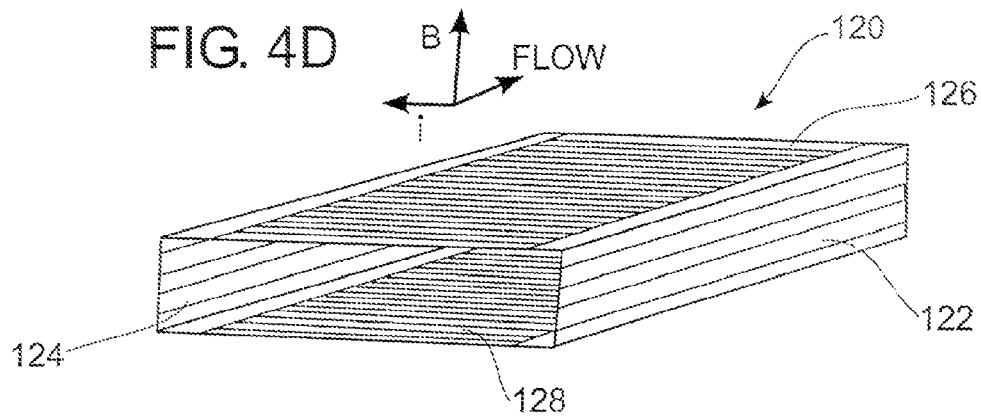

FIG. 5A

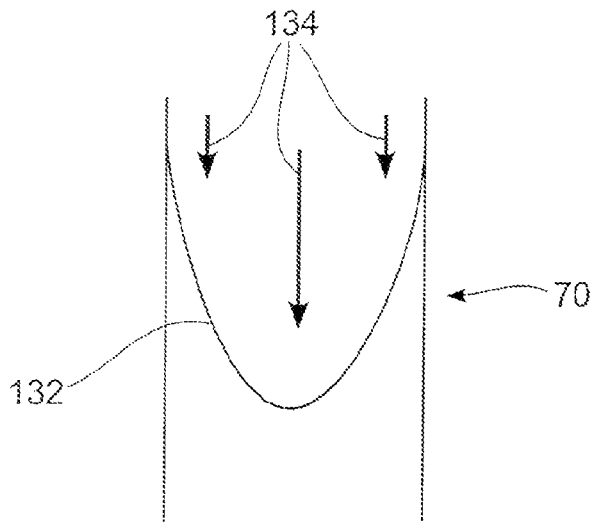

FIG. 5B

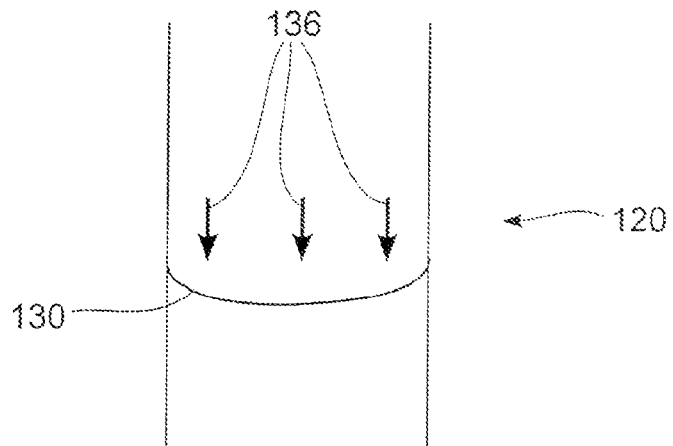

FIG. 6

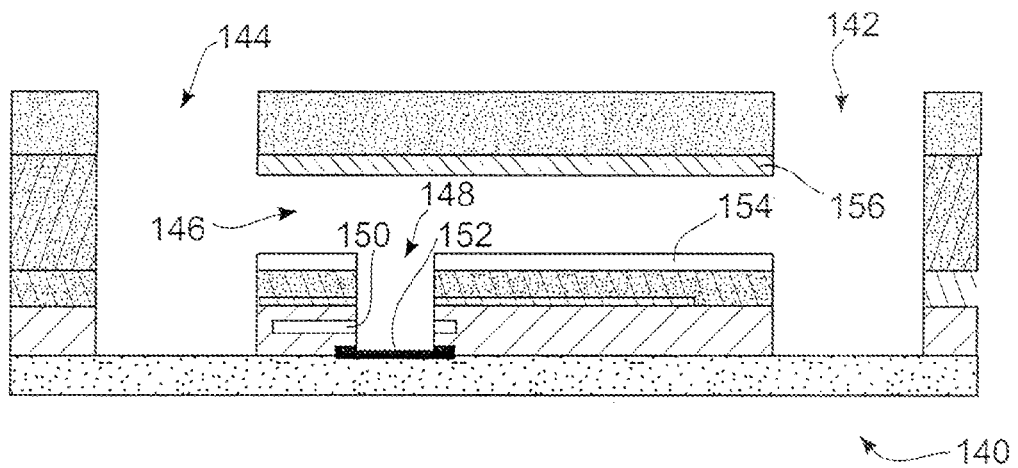

FIG. 7

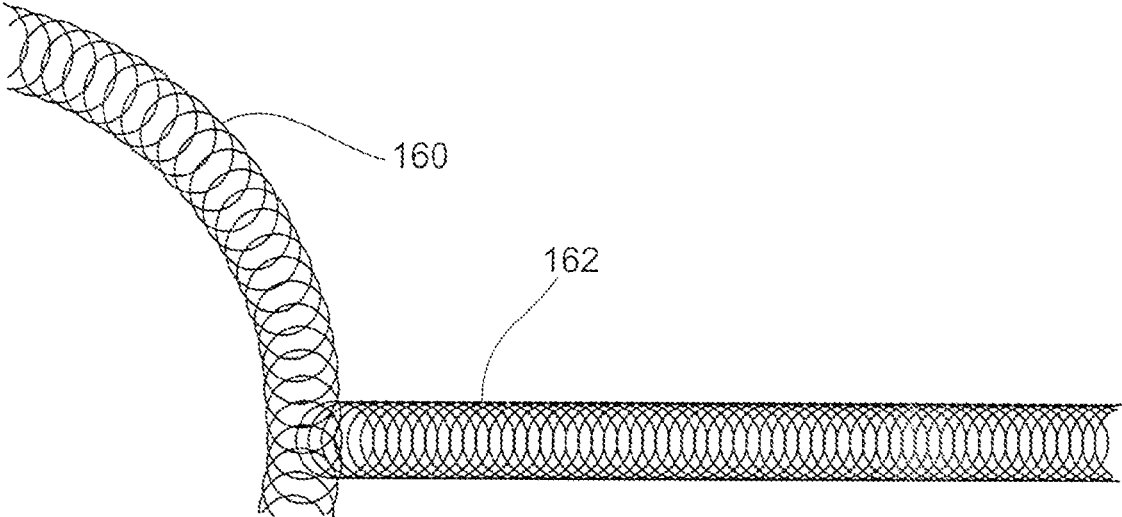

FIG. 8

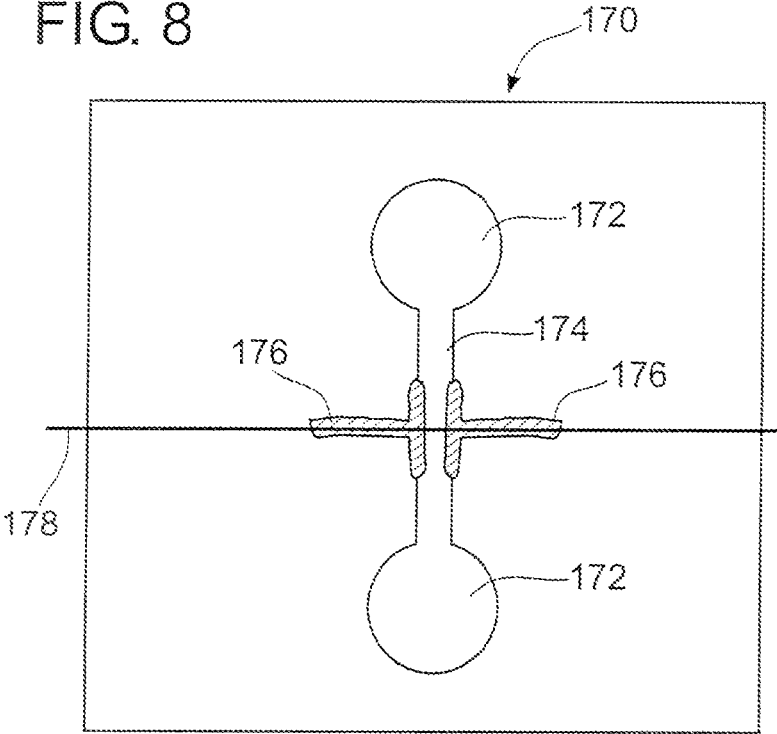

FIG. 9

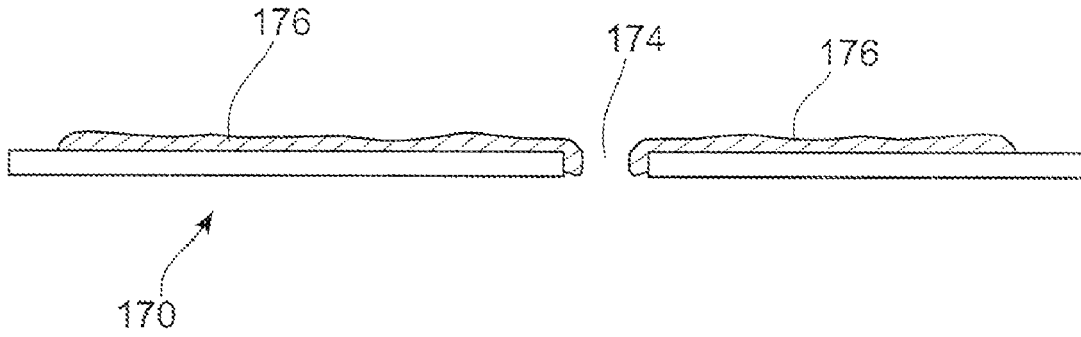

FIG. 10

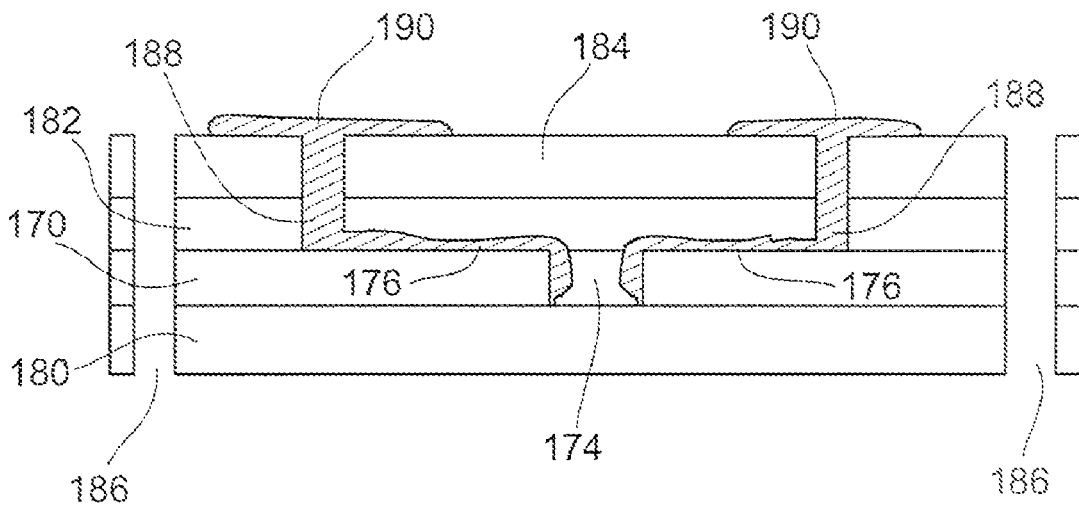



FIG. 11

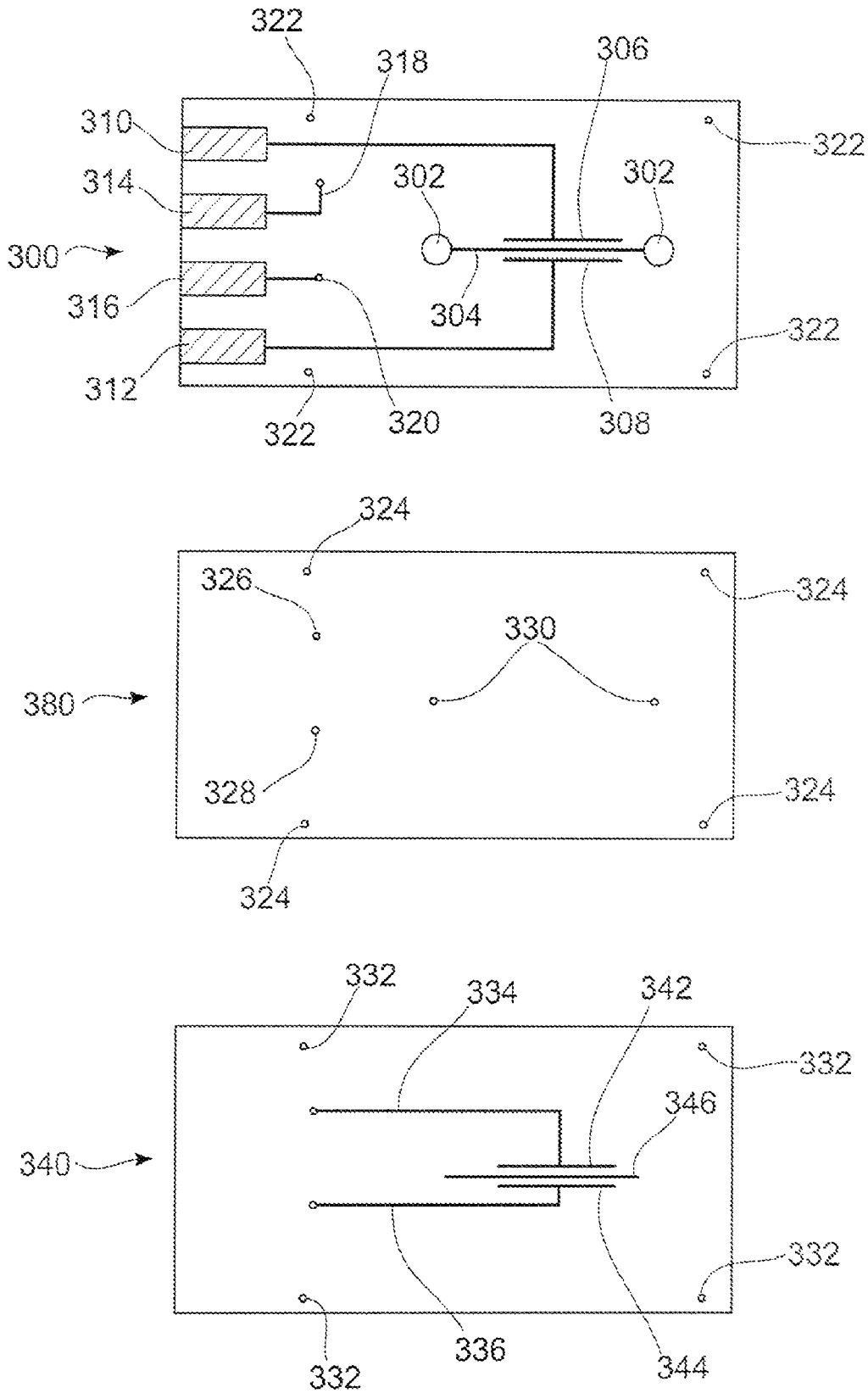

FIG. 12

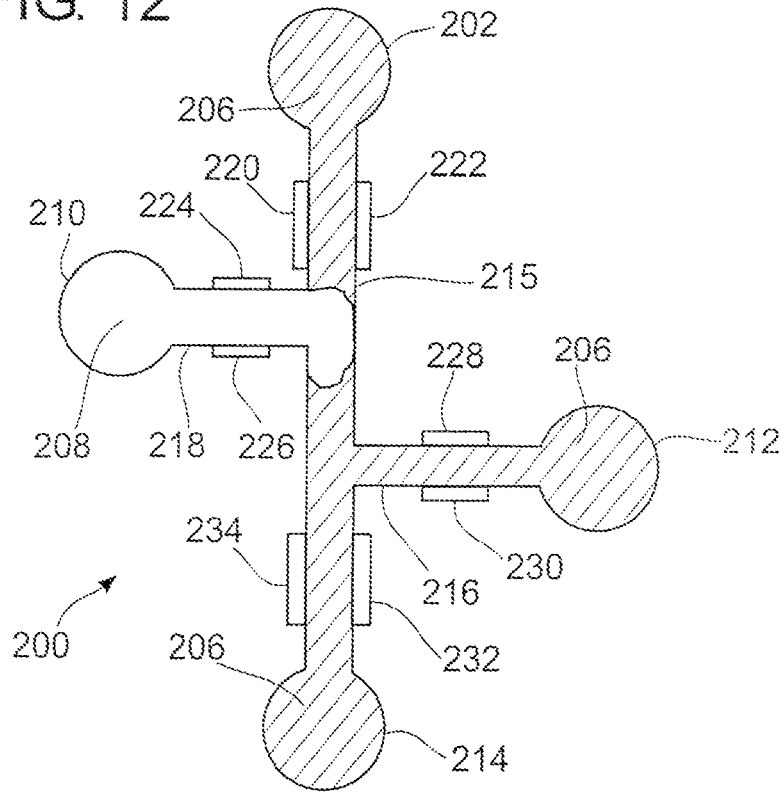

FIG. 13

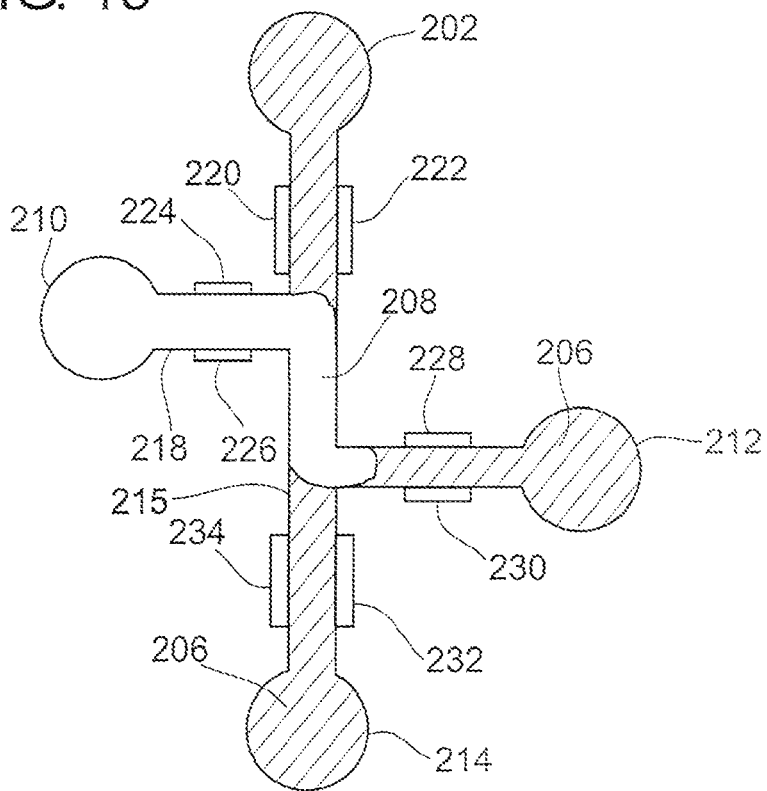

FIG. 14

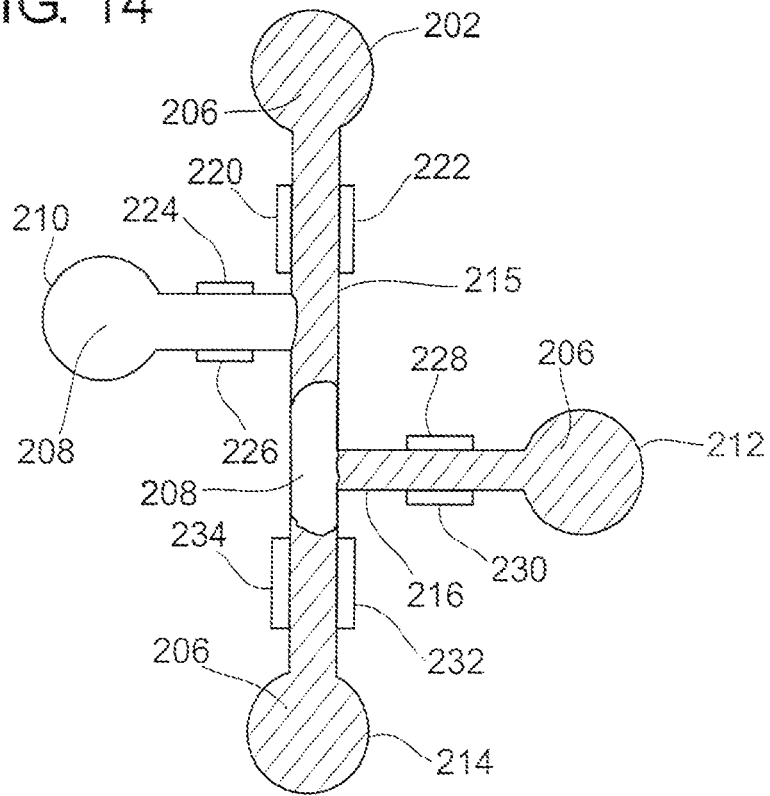

FIG. 15

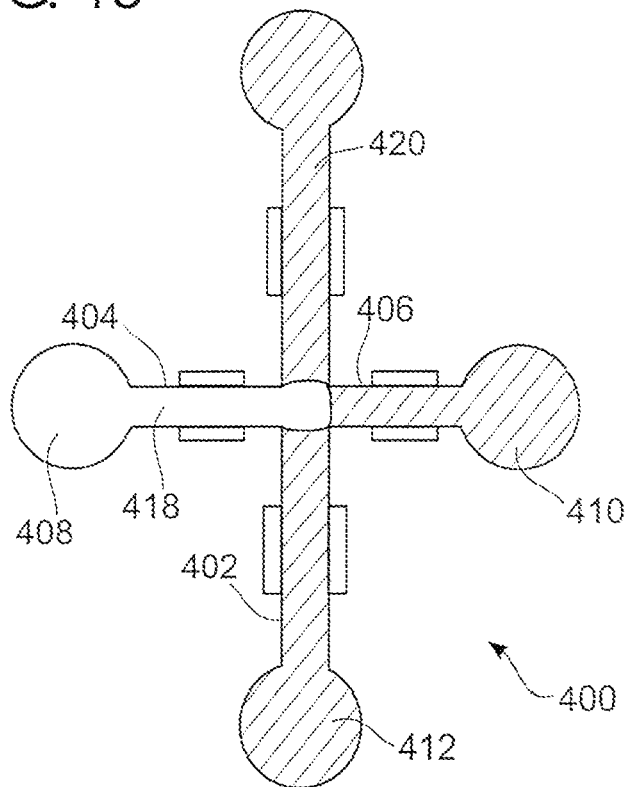

FIG. 16

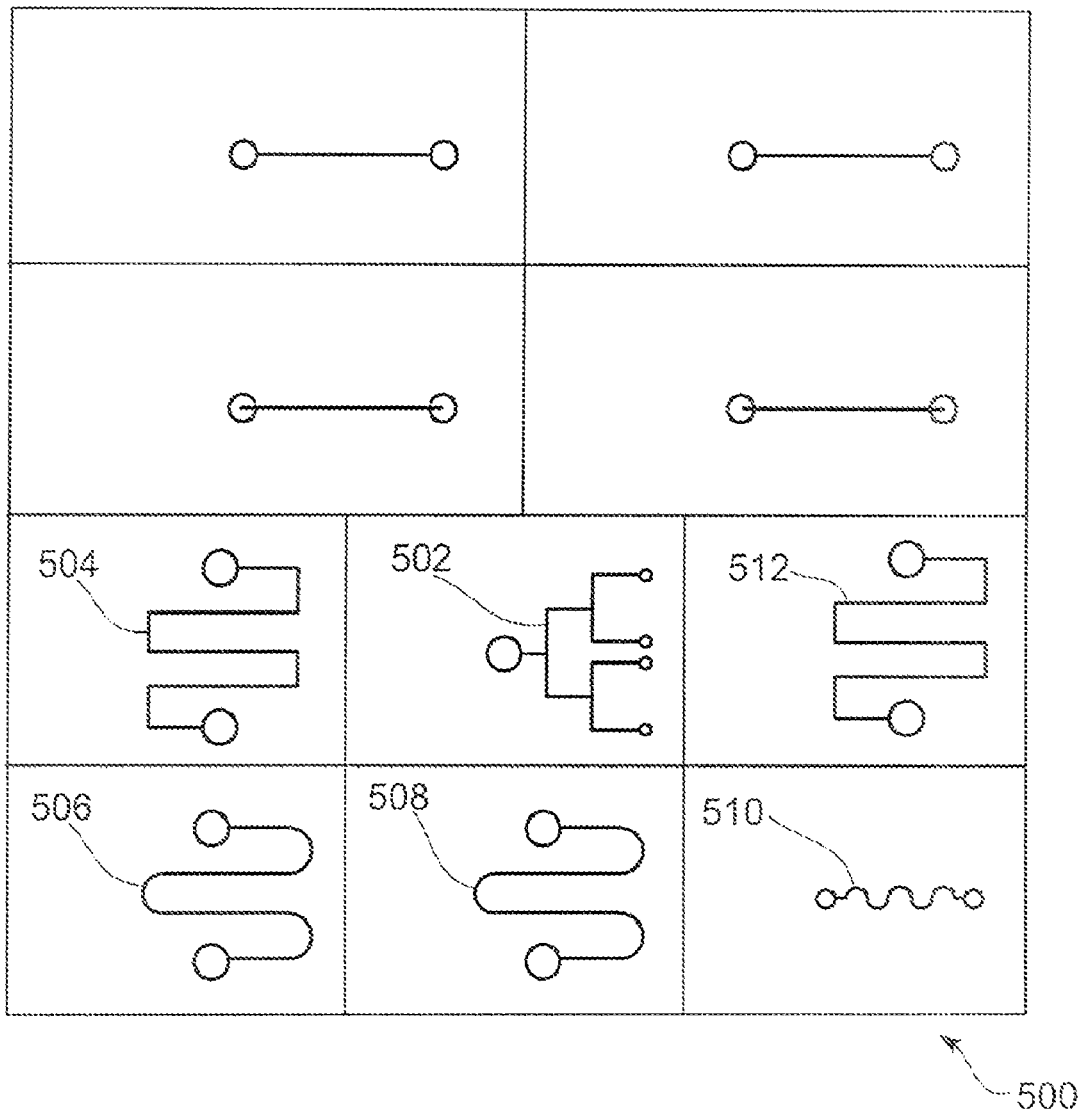
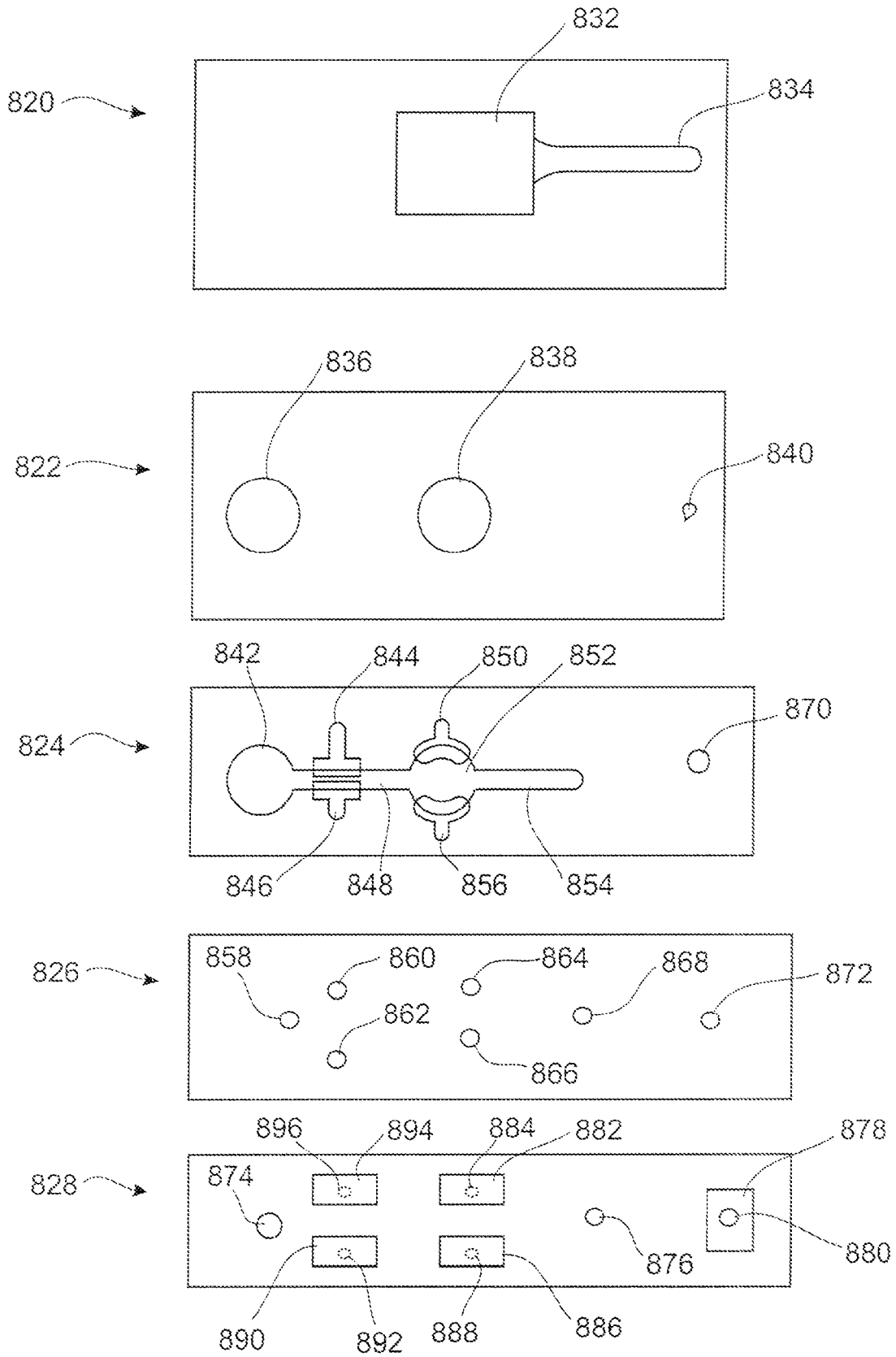

FIG. 17



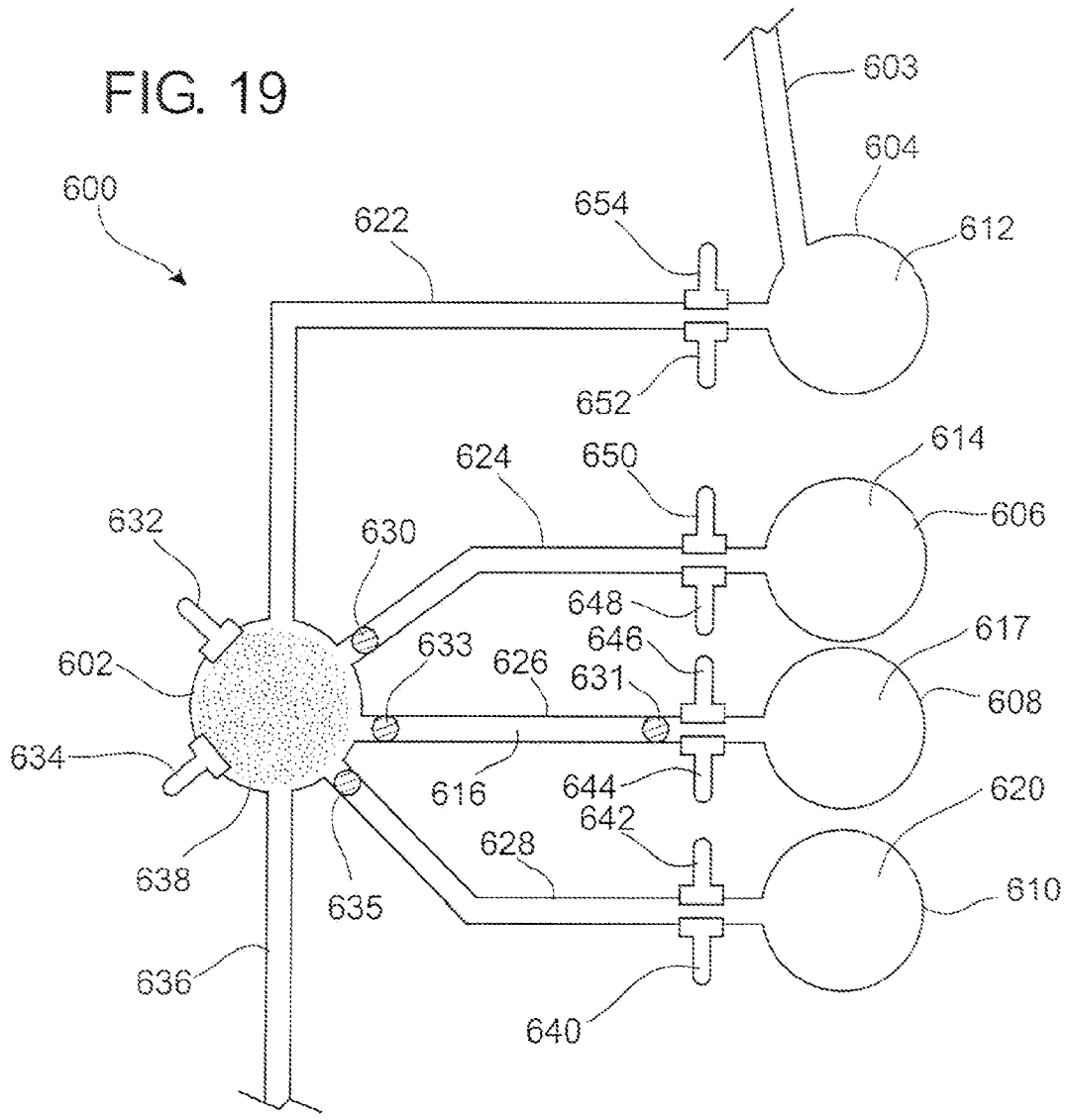
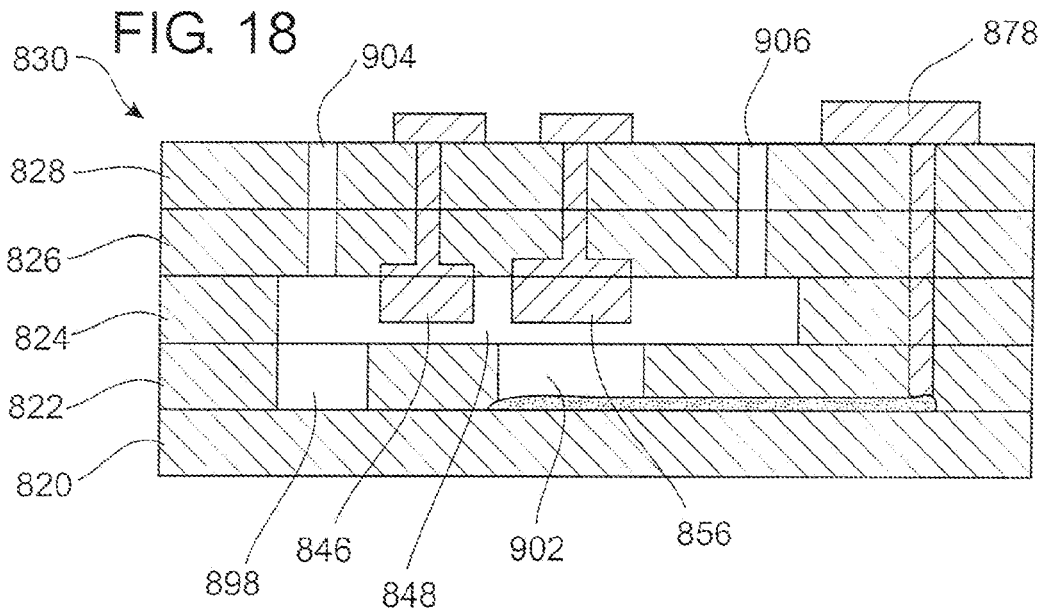

FIG. 20

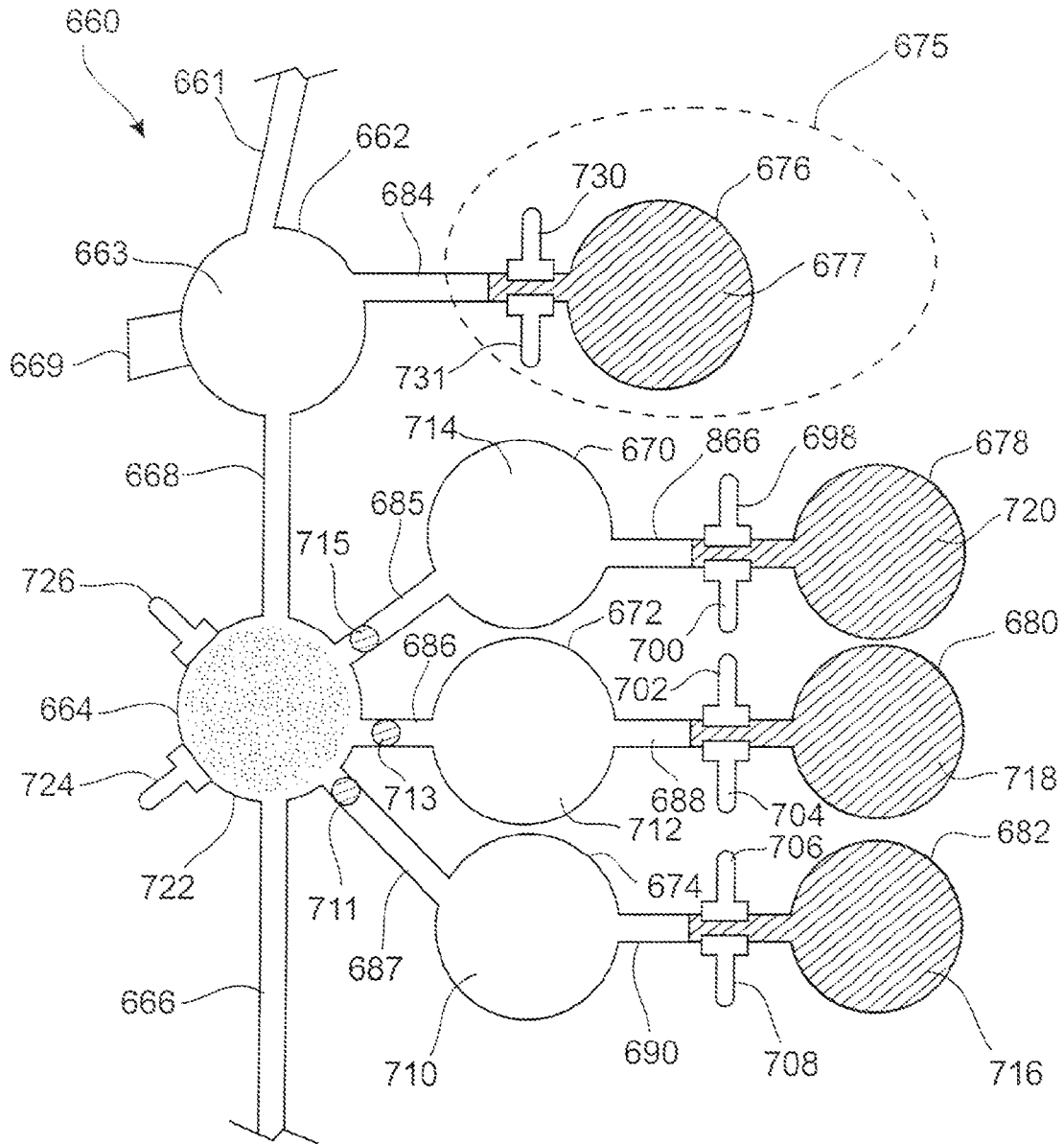
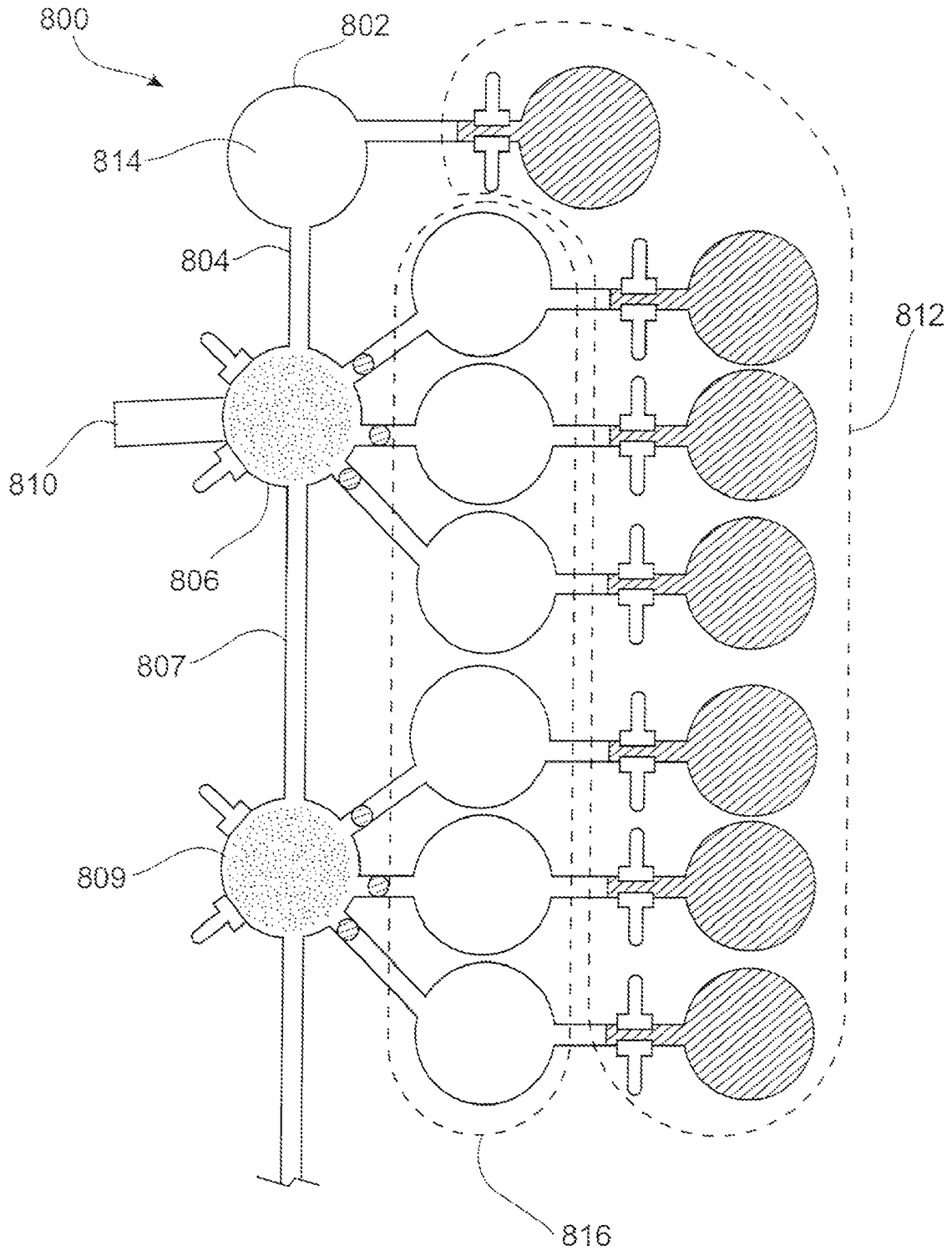

FIG. 21





**MICROFLUIDIC DEVICE UTILIZING  
MAGNETOHYDRODYNAMICS AND  
METHOD FOR FABRICATION THEREOF**

CROSS-REFERENCE TO RELATED  
APPLICATIONS

This application is a divisional of U.S. patent application Ser. No. 10/317,777, filed Dec. 12, 2002 now U.S. Pat. No. 7,147,441 and claims priority to U.S. patent application Ser. No. 10/026,748, now U.S. Pat. No. 6,733,244, filed Dec. 19, 2001 and claims priority to U.S. Provisional Application Ser. No. 60/257,331, filed Dec. 20, 2000 and claims priority to U.S. Provisional Application Ser. No. 60/278,275, filed Mar. 22, 2001 and claims priority to U.S. patent application Ser. No. 10/252,342, filed Sep. 23, 2002.

BACKGROUND OF THE INVENTION

1. Field of the Invention

The present invention relates to microfluidic devices. In particular, the present invention relates to the use of magnetohydrodynamics to propel or mix fluids within microfluidic structures.

2. Prior Art

The field of microfluidics is growing rapidly. There is a strong desire to miniaturize chemical assays. A number of various technologies are currently being developed in an effort to develop what has become known as lab-on-a-chip (LOC) technology. It is believed that these technologies will lead to mobile, small scale chemical testing devices. Such devices would have a variety of applications. Emergency Medical Technicians and military medics could use such devices to rapidly analyze a person's blood chemistry. Forensic scientists could perform DNA analysis at a crime scene, instead of waiting hours or days for results from a laboratory. Realizing the great potential of such devices, there have been many attempts to find a low power method of accurately propelling extremely small liquid samples through microfluidic structures. The desired width of these channels is less than 1 mm, preferably 500 micrometers or less, preferably 100 micrometers or less.

Some of the characteristics sought in a microfluidic propulsion system include high fluid flow rates, the ability to change direction of the flow, minimal power requirements and the ability to effectively propel a wide variety of fluids through structures composed of a wide variety of solid materials. High fluid flow becomes more difficult as microfluidic structures become smaller. This is due to increased drag created by moving along the walls of the microfluidic structure. A small power requirement is desired so that devices may be compact and portable. Different microfluidic technologies have advantages and disadvantages in these areas.

It has been found that by forming a gradient of a hydrophobic film across a glass or silica plate, water droplets can be induced to travel along the gradient. However, this method has only achieved relatively slow flow rates. In addition it is difficult to scale down to the microfluidic level of less than 500 micrometers. Hydrophobic films tend to work best on relatively large water droplets. It is impossible to change flow direction and is only effective on aqueous solutions.

There has been some experimentation in using temperature gradients to propel water through small channels. Although flow is reversible, flow rate is very slow. This technique also requires a relatively large power supply.

Electrokinetics has been a popular field of study in microfluidics. It provides for easy change of flow direction and is

suitable for very small channels. It is also well suited for separating chemicals. However, electrokinetics suffers from disadvantages. It is very sensitive to the chemical properties of both the fluid being manipulated and the walls of the channel. In addition, this technology requires high voltage and can only achieve relatively slow flow rates. Electrokinetics also will not work in the presence of air bubbles, which are common in microfluidic systems. Another disadvantage is that electrokinetics is ineffective on organic fluids. Like hydrophobic films, this method only works well on aqueous solutions. Application of a strong current may also alter chemicals present in the solution, thereby decreasing the accuracy of any analyses.

Mechanical methods of pumping fluids through microstructures also pose several problems. The mechanical methods usually require valves which can complicate fabrication and become clogged. Complex mechanical devices, including many valves, are difficult to scale down to small sizes. In addition, mechanical pumping usually requires a pulsating flow and it does not conveniently allow changes in flow direction.

Centrifugation is inexpensive and adaptable to a wide range of channel sizes. However, the flow direction cannot be reversed and this process usually involves a single-use cartridge. Centrifugation also requires a large power supply. These power requirements rapidly increase and the microfluidic structure size decreases due to drag.

There is a need for alternative non-mechanical pumping systems that are lower power, operate with a wider range of device materials and solutions compositions, offer multi-use capabilities, and allow easy change in flow direction.

Magnetohydrodynamics (MHD) has been proposed as an alternative method for microfluidic propulsion. This technology involves the application of a magnetic field and a electric field. The two fields are applied perpendicular to each other and perpendicular to the desired direction of flow. These fields induce fluid flow perpendicular to both fields. This is known as a Lorentz force. On larger scales, the Lorentz force is too weak for any practical applications and until recently has been considered only a curious phenomenon.

MHD works best when current density is high, and most electrodes have fairly low current density. However, because of the physics unique to small scale diffusion, microelectrodes exhibit very high current densities. MHD is therefore much more practical at very small scales. Relatively little power, less than one volt, can achieve high flow rates in microfluidic structures.

MHD is very susceptible to change of flow direction. By simply alternating the electrodes, the direction of fluid flow reverses. Similarly, reversing the magnetic field will also reverse flow direction. The ease of change in flow direction coupled with low power and high flow rate make MHD an excellent mechanism for microfluidic propulsion. In addition, Lorentz forces apply to all fluids, so that MHD may effectively propel both aqueous and organic solutions. MHD is also unaffected by the materials used to construct microfluidic structures.

There have been limited attempts to apply MHD technology to microfluidics already. It has been used successfully on molten metals and mercury. However, these generally involve high temperatures and are not well suited to be used in conjunction with chemical assays. These methods have high power requirements and chemical assays are generally not designed to utilize molten metals.

More recently, attempts have been made to apply MHD to aqueous solutions. Channels have been constructed having electrodes on opposing walls. A magnetic field is then applied

perpendicular to both the direction of flow and the electric field generated by the electrodes. Unfortunately, a significant problem has arisen due to water electrolysis. Although insignificant on larger scales, bubbles formed by water electrolysis within a microstructure pose serious problems. Aside from blocking fluid flow, they also disrupt the electric field. This in turn disrupts the Lorentz forces and halts fluid flow completely. Only very low voltage, which results in very slow flow rates, have been shown to be practical. At higher voltages, water electrolysis makes MHD impossible. In addition, MHD is ineffective when applied to hydrophobic, oily solutions that have dielectric points greater than that of water.

There have been attempts to use an alternating current in conjunction with a synchronous alternating magnetic field to counteract the electrolysis of water. By constantly reversing the fields, bubble formation is reduced. Unfortunately, this only provides for a minimal increase in voltage and flow before electrolysis occurs. In addition it is much more difficult to perform. It requires precise shifts in the electric and magnetic fields, otherwise the fluid does not flow at all.

It is therefore desirable to provide a microfluidic propulsion technique that requires relatively little power.

It is also desirable to provide a microfluidic propulsion technique that utilizes a constant magnetic field.

It is also desirable to provide a microfluidic propulsion technique that may be used on a variety of fluids, specifically aqueous and hydrophobic solutions and structures.

It is also desirable to provide a microfluidic propulsion technique that does not induce water electrolysis.

#### BRIEF DESCRIPTION OF THE DRAWINGS

FIG. 1 shows a schematic diagram of a magnetohydrodynamic device.

FIG. 2 shows a schematic diagram of an alternative magnetohydrodynamic device formed on a glass substrate.

FIG. 3 shows a cross-sectional view of the schematic diagram of FIG. 2.

FIG. 4A shows a perspective view of a magnetohydrodynamic channel.

FIG. 4B shows a perspective view of an alternative magnetohydrodynamic channel.

FIG. 4C shows a perspective view of an alternative magnetohydrodynamic channel.

FIG. 4D shows a perspective view of an alternative magnetohydrodynamic channel.

FIG. 5A shows a schematic diagram of a flow pattern of a solution within a magnetohydrodynamic channel.

FIG. 5B shows a schematic diagram of an alternative flow pattern of a solution within a magnetohydrodynamic channel.

FIG. 6 shows a schematic diagram of an alternative magnetohydrodynamic device.

FIG. 7 shows a schematic diagram of a hole punch pattern for forming a magnetohydrodynamic device on ceramic tape.

FIG. 8 shows a schematic diagram of a magnetohydrodynamic device formed on a piece of ceramic tape.

FIG. 9 shows a cross-sectional view of the schematic diagram of the magnetohydrodynamic device of FIG. 8.

FIG. 10 shows a schematic diagram of a magnetohydrodynamic chip comprised of ceramic tape and incorporating the ceramic tape of FIGS. 8 and 9.

FIG. 11 shows a schematic diagram of a series of pieces of ceramic tape designed to form a magnetohydrodynamic chip having a feedback loop.

FIG. 12 shows a schematic diagram of an alternative embodiment of a magnetohydrodynamic device.

FIG. 13 shows the magnetohydrodynamic device of FIG. 12 after analyte solution has entered the main channel.

FIG. 14 shows the magnetohydrodynamic device of FIG. 12 where the device is pumping the analyte solution toward a reservoir.

FIG. 15 shows an alternative embodiment of a magnetohydrodynamic device.

FIG. 16 shows alternative design patterns for microfluidic channels on ceramic tape.

FIG. 17 shows a series of pieces of magnetic tape that may be stacked to form the microfluidic chip shown in FIG. 18.

FIG. 18 shows a microfluidic chip capable of performing a redox assay.

FIG. 19 shows a schematic diagram of a microfluidic assay structure.

FIG. 20 shows an alternative microfluidic assay structure.

FIG. 21 shows a schematic diagram of an alternative microfluidic assay structure.

#### SUMMARY OF THE INVENTION

The invention disclosed here is a new method of microfluidic propulsion and a set of devices that promises to solve many of the problems that other existing microfluidic methods suffer from. This new approach is capable of moving small volumes of fluids through a channel, in either direction, without valves. These devices may be constructed from a variety of materials and use voltages that are in the millivolt to volt range. In addition, this invention utilizes relatively small, constant magnetic fields that can be provided by small permanent magnets. The method disclosed is effective on extremely small samples, less than 100 picoliters. MHD is also a readily reversible method of pumping. These characteristics make this invention especially suitable for use in LOC technology. It may be used for chemical analysis of very small samples, such as those common in forensics, DNA and medical testing.

In order to avoid water electrolysis, chemicals that are highly susceptible to reduction/oxidation are added to the solution prior to its addition to the microfluidic system. These reduction/oxidation (redox) chemicals serve as "ferries" transporting electrons from the anode to the cathode. Once oxidized at the cathode, they return to the anode where they are once again reduced. This cycle is repeated many times. By using redox chemicals in the fluid as electron transporters, electrolysis of water is avoided. The redox species in the solution are propelled in a direction perpendicular to both the electric and magnetic fields. This movement of the redox species causes the entire solution to flow in the same direction. This constitutes a significant improvement over existing microfluidic technology.

In addition to redox species, other current carrying species may be used. Metallic nanoparticles may be added to the solution in order to accomplish the same motion as redox compounds. The nanoparticles ferry electrons, thereby allowing current to flow through the solution. This is necessary for the Lorentz forces to take effect. The movement of nanoparticles causes the entire solution to move.

Mixing is generally difficult with extremely small volumes. Sample preparation and assays, such as immunoassays and DNA analysis, involve combining of reagents in very small amounts. Small samples pose challenging problems in analyzing their content, since signal of small volumes is generally small or requires special equipment to achieve high sensitivity. Some chemical detection methods, such as electrochemical detection, have a signal that depends on how fast the molecular species move past the detector or a modified

5

surface which captures the analyte. The inability to mix extremely small volumes allows diffusion to predominate and significantly reduces the accuracy of small sample analysis. The invention disclosed herein allows mixing of such small samples and can significantly improve the accuracy of small sample analysis. Methods of mixing extremely small samples have eluded scientists for years. In the present invention, relatively high concentration of current carrying species, such as redox chemicals, nanoparticles, or the like are usually used. This guarantees the inhibition of water electrolysis. The current carrying species carries the entire current. This also rapidly and effectively mixes samples as small as a hundred picoliters. The rapid movement of the redox species or nanoparticles mixes the solution.

Another advantage provided by the present invention is that a wide variety of redox chemicals may be used. It may be desirable to use MHD microfluidic technology to analyze chemicals that react with various redox compounds. In such situations, a different, non-reactive redox chemical, nanoparticle or the like may be employed instead without any adverse effects. This ability to choose from a wide range of suitable current carrying species makes the present invention more practical and more adaptable than other microfluidic pumping methods. It is also possible that small scale, portable LOC devices may be exposed to various extreme conditions. Some conditions such as extreme pressures, heat or cold may have

6

field passes through the two remaining walls, perpendicular to the electric field created by the electrodes. A solution having a current carrying species is introduced to the channel. Lorentz forces affect the current carrying species, propelling them in a direction perpendicular to both the electric and magnetic fields. The current carrying species in turn causes the solution to move through the channel.

The magnetohydrodynamic microfluidic systems disclosed herein are especially suited for the formation of microfluidic assay structures that allow the performance of chemical detection assays within very small chips. Reduction/oxidation assays, ELISA's polynucleotide hybridizations and other immobilization assays may all be performed within microfluidic assay structures. These assays, because of their electrochemical nature and small volume, are fast, reliable, sensitive and easily transported.

It is therefore an object of the present invention to provide an effective method of microfluidic pumping.

It is another object of the present invention to provide a method of using (MHD) technology to pump microfluidic samples without inducing water electrolysis.

It is another object of the present invention to provide a method of rapidly and effectively mixing extremely small samples. It is another object of the present invention to provide a method of pumping microfluidic samples that is effective for a wide variety of sample solutions.

#### FEATURES OF MICROFLUIDICS

Feature	Electro-kinetic	Mechanical	Centrifugal	Magnetohydrodynamic
Flow and Profile	Limited (slow) & flat	Variable & non-flat	Variable & non-flat	Variable (slow) & non-flat
Reversible	Yes	Yes (valves, pushed)	No	Yes
Direction			For Spinning	
Voltage & Power	High (100's to 10000's V)	For pump devices		0.01 V to 1 V
Versatile Materials and Solvents	No	Yes	Yes	Yes
Easy to Miniaturize, low complexity	Yes (device) No (power)	no (moving parts, valves)	No (moving parts, detection)	Yes (battery)

45

an adverse effect on certain redox chemicals. Again, in these situations specific redox chemicals may be employed that best suit a given situation.

The present invention also allows the pumping action of the MHD microfluidics channel to be separated from the analyte solution. A hydrophobic solution having a current carrying species may be used to push an aqueous solution through a microfluidic channel. The two solutions will not mix together. This provides many advantages. Many analytes may react with redox species or nanoparticles to form different compounds. This will decrease the accuracy of any measurements of the analyte. Current carrying species may disrupt the method of detection of the analyte, causing false positives or false negatives. By separating the analyte solution from the pumping solution, the analyte remains unaffected.

In the present invention, a small channel is formed through which the fluid flows. To avoid evaporation, the channel is enclosed on four sides. Two opposing sides consist of electrodes. It is usually desirable that these electrodes be switched, so that each alternates between being a cathode and an anode allowing direction of flow to reverse. A magnetic

#### DETAILED DESCRIPTION OF THE PREFERRED EMBODIMENTS

The embodiments discussed herein are merely illustrative of specific manners in which to make and use the invention and are not to be interpreted as limiting the scope of the instant invention.

While the invention has been described with a certain degree of particularity, it is to be noted that many modifications may be made in the details of the invention's construction and the arrangement of its components without departing from the spirit and scope of this disclosure. It is understood that the invention is not limited to the embodiments set forth herein for purposes of exemplification.

MHD Lorentz forces have been known to physicists for almost 200 years. It involves 3 physical fields all perpendicular to one another. The flow or velocity field is aligned perpendicular to both the magnetic and electric fields which are also perpendicular to one another. Manipulation of any two of these fields results in a change in the third one. In the present

invention, an electric field and a magnetic field are applied to a channel both being perpendicular to the desired direction of flow.

MHD technology requires a relatively dense current in order to induce a significant rate of flow through the channel. At larger scales this is not practical. Small scale, microfluidic channels however, because of the unique properties associated with microelectrodes in close proximity to one another, allow for relatively high current densities. These may be combined with natural magnets. Magnetic fields on 0.4T or less may be adequate. Because natural magnets and a low amount of electricity are all that is required, MHD technology is especially well suited for LOC.

Microfluidic MHD channels may be constructed from a variety of materials. Channels formed from ceramic tape and glass slides are discussed in detail below. However, any substrates susceptible to microfabrication are suitable.

The current carrying species may be any chemical compound capable of readily acquiring and releasing one or more electrons. Those skilled in the art of chemistry will recognize that there are a large number of chemical compounds, generally known as redox compounds or species, that would serve as adequate current carrying species. Two common examples of well known redox compounds are ferricyanide and hydroquinone. Also, small particles, called nanoparticles, may serve as adequate current carrying species. Nanoparticles may be comprised of metals, carbon fibers, conductive plastics or the like. Depending on the solution to which they are added, redox species or nanoparticles may be hydrophobic, hydrophilic or amphoteric.

FIG. 1 illustrates the principles by which the present invention operates. Electrodes **10** and **16** are connected to an electrical power source **12**. Electrode **16** works as a cathode while electrode **10** works as an anode. This creates an electrical field represented by directional arrow **14**. Natural magnets, not shown in this drawing, are used to apply a magnetic field represented by directional arrow **18**. The magnetic field is applied perpendicular to the electric field. Current between cathode **16** and anode **10** is carried by a current carrying species **22**. Current carrying species **22** acquires an electron from anode **10** and is transformed into the reduced form of species **24**. The reduced species **24** then carries the electron to cathode **16** where it discharges it and transforms into the oxidized species **22**. This process is repeated many times. Electric field **14** created by the redox cycling of the current carrying species, in conjunction with the magnetic field, induces flow of the current carrying species in the direction of directional arrow **20**. The flow induced within the current carrying species is transferred to the entire solution located between the electrodes.

FIGS. 2 and 3 illustrate a MHD channel formed between 2 glass slides. To form this microchannel, an electrode is first deposited on each glass slide. An insulating material is then used to form a channel on one slide and then the second slide is attached. The slides are positioned in such a way that the electrodes deposited each run along a wall of the channel. Reservoirs are then placed at each end of the channel, a magnetic field is applied, and current is sent through the electrodes. A current carrying species within the solution carries the current and creates an MHD effect. In FIG. 2 MHD device **30** has an upper reservoir **32** and a lower reservoir **34**. Lower reservoir **34** is sealed so that it is air tight and is connected to upper reservoir **32** by pressure equalizing tube **36**. As solution is transferred to upper reservoir **32**, a partial vacuum is created in lower reservoir **34**, making it more difficult for the device to draw solution out of reservoir **34**. Equalizing tube **36** relieves this vacuum pressure.

Class slides **42** and **44** have electrodes **46** and **48** respectively. Electrodes **46** and **48** are on the sides of slides **42** and **44** that face each other. This way electrodes **46** and **48** lie along 2 opposite walls of the channel. Insulating material **38** and **40** lie between slides **42** and **44**, and adhere to each of them. Insulating material **38** and **40** may be comprised of any of a number of materials. Polydimethylsiloxane (PDMS) elastomer, polyimide and various photo resists may all be used. It is also possible to use double sided adhesive tape for the insulating material.

FIG. 3 shows a cross sectional view of an MHD channel formed by the following process:

#### Device Fabrication Procedure

##### Electrode Fabrication

1. Glass microscope slides are piranha cleaned for 30 minutes then rinsed thoroughly with water.
2. Deposit a 100 Å chromium adhesion layer, then 6000 Å of gold on a glass microscope slide using a thermal evaporator.
3. Coat the deposited glass slides with approximately 1.5 mL of HPR-504 positive photoresist.
4. Spin coat the slides for 20 seconds at 2000 rpm.
5. Bake the slides for 9 minutes at 103° C. on top of petri dishes.
6. Place the electrode photoplot film ink-side down on top of the deposited slide and place another slide on top of the film.
7. Expose slides to UV light for 30 seconds for each half of the slide (1 minute total).
8. Develop the exposed slide for 1 minute in a 50:50 solution of water:developer solution.
9. Place the slides in Aqua Regia (3:1 HCl:HNO<sub>3</sub>) for 3-4 minutes or until the gold is etched away. Rinse with water.
10. Place the slides in a Chromium Etch agent for 1 minute, or until all of the chromium has been etched away. Rinse with water.
11. Rinse all remaining photoresist away with acetone and rinse with water.

The pattern from the electrode film should now be transferred onto the glass slide.

##### Channel Mold Fabrication

1. A silicon wafer is piranha cleaned for 30 minutes then rinsed thoroughly with water.
  2. Coat the wafer with SU-8 25 (Microchem Corp), a negative photoresist.
  3. Spin coat the wafer for 30 seconds at 2000 rpm.
  4. Soft bake the wafer to 5 minutes at 95° C.
  5. Place the channel film ink-side down on top of the wafer and place a microscope slide on top of the film.
  6. Expose the wafer for 5 minutes.
  7. Hard bake the wafer to 15 minutes at 95° C.
  8. Develop the exposed wafer to 3 minutes (1 minute of agitation and soaking for 2 minutes) in SU-8 Developer.
  9. Spray with fresh developer.
  10. Bake at 60° C. until dry.
- The mold should be hard.

##### Transferring Channel to Electrode Slide

1. Mix polydimethylsiloxane (PDMS) elastomer and curing agent (10:1 by weight) thoroughly.
2. Degas mixture for 10-30 minutes.
3. Pour mixture on top of channel mold.
4. Press electrode slide firmly against the channel mold.
5. Bake for 1-3 hours at 60° C. until cured.

6. Peel the electrode slide and the channel mold wafer apart. The PDMS should adhere to the glass electrode slide, thereby transferring the channel design onto the electrode slide.
7. Clear the residual PDMS out of the channels using a sharp object (i.e. razor blade).
8. Piranha clean the electrode slide with the PDMS and another electrode slide (which has holes drilled in it for the reservoirs) for 15 minutes and rinse thoroughly with water.
9. Immediately rinse both slides with methanol and press them together (gold sides facing each other).
10. Bake at 65° C. until methanol is completely dry. The two slides should now be joined together.

This process creates the sandwich arrangement in FIG. 3. In the particular embodiment described above, glass slides **52** and **54** are used as the beginning substrate. However, any substrate susceptible to any process of depositing layers of conducting material may be used. Oxidized silicon wafers and polyimide films are examples of other suitable substrates.

The channel formed by this process may be as little as 12 microns wide and 12 microns long. However, it is also possible to form channels 12 microns wide and several millimeters long. This process allows the formation of a structure having several channels in a variety of designs.

Also in this embodiment, thermal evaporation is used to deposit gold electrodes **58** and **56** onto slides **52** and **54** respectively. However, those skilled in the art will appreciate that there are a variety of methods for depositing these electrodes. Electron beam evaporation, sputtering deposition, spin coating, molecular beam epitaxy or the like are suitable alternatives to thermal evaporation. The preferred method of deposition will depend on the type of substrate used, the use to which the MHD device is to be put, the desired characteristics of the MHD device and other factors known to those skilled in the art.

Those skilled in the art will also appreciate that gold is only one of many suitable materials for the conducting layer. Other metals such as copper and aluminum are suitable for use as electrodes. It may also be desirable to use non-metallic conductors, such as carbon fibers for the electrode layer.

Insulating layer **60** is sandwiched between slides **52** and slides **54** in order to form channel **62**. Slides **52** and **54** are positioned such that electrodes **58** and **56** face one another. Slides **52** and **54** are off set from one another to facilitate attachment of conducting wire **64** and **66** that lead to an electrical current source. In this particular embodiment, PDMS is used as the insulating layer. This layer may be as thin or as thick as desired. The only limit on the thickness of the layer is that it must be thick enough to prevent shorting between electrodes **58** and **56**.

FIGS. **4A**, **4B**, **4C** and **4D** all show alternative designs for a MHD channel. In FIG. **4A**, general MHD channel **70** has a basic design. Anode **76** comprises 1 of 4 walls of the channel. Cathode **78** comprises the opposite wall of channel **70**. Side walls **72** and **74** are comprised of an insulating material. FIG. **4A** illustrates the simplest design where anode **76** and cathode **78** each comprise an entire wall of the channel.

FIG. **4B** illustrates a more complex design for channel **70**. In this embodiment, wall **86** has a series of anode bands **92** running down the length of the wall. Here there are 3 anode bands **92** but this number may vary. Similarly, wall **84** has a series of cathode bands **80** running along its length. Preferably there are the same number of anode bands **92** and cathode bands **80**. However, this is not necessary. Side walls **88** and **90** are comprised of insulating materials.

FIG. **4C** shows another alternative embodiment for channel **70**. In this particular embodiment, anode bands **104** are located on the edges of wall **110** in the corners of the channel created by walls **110**, **106** and **108**. Similarly, cathode bands **102** are located in the corners formed between wall **112** and walls **106** and **108**. Those skilled in the art will realize that the different geometries found in **4A**, **4B** and **4C** are slight and that the channels are substantially similar.

FIG. **4D** shows an alternative embodiment that has significant differences from the other illustrated embodiments. Channel **120** is specifically designed to alter the flow profile of the fluid within the MHD channel. Microfluidic channels impose a significant amount of drag on solutions that pass through them. This creates a "D" shaped flow profile. In some situations, it may be advantageous to have a more square shaped flow profile. Channel **120** alters the flow profile by replacing the insulating walls with passive equilibration conducting walls **126** and **128**. Passive equilibration conducting walls **126** and **128** contact anode wall **122** and cathode wall **124**. The partial equilibration conduction caused by walls **126** and **128** effect the flow pattern of the fluid within the channel **120**.

The magnets used to induce the magnetic field are not shown in these drawings. Those skilled in the art will understand that the magnets do not need to be in actual physical contact with the channel or the solution within the channel. It is only necessary that magnets be positioned close to the MHD channel in order to induce a magnetic field in the proper orientation.

FIGS. **5A** and **5B** illustrate different flow patterns. FIG. **5A** illustrates the flow through general channel **70**. Fluid **132** flows unevenly as indicated by flow vector arrows **134**. The least amount of drag is experienced by the portion of the fluid in the middle of the channel. This creates a cone shaped flow pattern. FIG. **5B** illustrates a square shaped flow pattern. Fluid **130** moves at an even rate as indicated by flow vector arrows **136**. Passive equilibration causes this type of square shaped flow pattern.

FIG. **6** shows a microfluidic MHD channel combined with a microcavity sensing device. Microfluidic structure **140** has a first reservoir **142**, a second reservoir **144**, a microfluidic MHD channel **146** and a microcavity **148**. The magnet used to induce a magnetic field is not shown in the illustration. Electrodes **156** and **154** are used in conjunction with an exterior magnet to create the MHD effect. This causes solution in reservoir **142** to enter channel **146** and pass through it, eventually reaching reservoir **144**. When the solution encounters microcavity **148**, microcavity electrodes **150** and **152** may be used to detect various analytes. Such microcavities are described in detail in U.S. patent application Ser. No. 09/946, 249 and U.S. patent application Ser. No. 09/978,734. The microfluidic structure shown in FIG. **6** is a relatively simple design. It may be desirable to incorporate several microcavities along the wall of microfluidic MHD channels. The presence of the magnetic field also induces mixing within the microcavity. This can increase the speed and accuracy of the detection of analytes within the analyte solution.

In an alternative embodiment of microfluidic MHD channels, the channels are fabricated in ceramic tape commercially available from DuPont. The microfluidic devices are fabricated on Green Tape™ 951 series and 851 series. The designs consist of microchannels fabricated on 6 in.<sup>2</sup> pieces of substrates with gold electrodes screen printed on the side-walls of the channels. The thickness of the screen print is 12 um. These electrodes extend to form contact pads at the side of the chip for edge connectors. The gold electrodes form the electrical part of the magnetohydrodynamic pump.

The material used in fabrication is known as Green Tape™ and is also known as Low Temperature Co-fired Ceramic (LTCC). In the pre-fired state the ceramic tape consists of alumina particles, glass frit and organic binder. In the pre-fired state the ceramic tapes are soft, pliable and easily machinable. Mesoscopic features ranging in size from 10 μm to 10 mm can be machined using mechanical, chemical and thermal means. This material is compatible with high conductivity metals such as gold and silver.

Green Tape™ comes in two varieties. The 951 series and the 851 series both have similar compositions but the 851 is white in the pre-fired state and the 951 is blue.

#### Fabrication Terminology:

Via—hole punched in ceramic tape using a punching machine.

Filled vias—vias filled with metal to form electrical interconnects between layers.

Catchpads—patches of metal printed on the tape directly above filled vias to assist with the electrical interconnect.

Registration holes—vias punched at four corners of the ceramic tape to assist in stacking of the tapes during the lamination process.

Alignment holes—vias close to the registration holes to assist with alignment during the screen print process.

Screen print—process of printing metal onto the ceramic tape.

The fabrication process for the Green Tape™ proceeds in several steps. The tape comes in a roll, which is cut into 6 in<sup>2</sup> pieces, then cured at 120° C. for 30 minutes. Then registration and alignment holes are punched along with other features necessary for the overall function of the device such as microchannels are vias. Each layer is fabricated separately. These individual layers will eventually be arranged in the proper order (stacked) to form a 3D structure. The next step after punching is the via fill. In this stage vias are filled with metallic, conductive ink. These help to form electrical interconnections between layers. After this, screen-printing of the gold electrode ensues. By this stage all the microchannels have been punched on the tape and the sidewalls of the microchannel are coated with metal by pulling a vacuum through during the screen print (FIG. 9). After the screen print process is lamination. With the aid of the registration holes the various layers are stacked together then vacuum sealed and a hydraulic pressure of 3500 psi at 80° C. is applied for 10 minutes. Then the substrate is baked at 850° C. for 8 hours.

The Green Tape™ shrinks on heating. There is a 12% shrinkage in the x,y plane and 15% shrinkage in the z-axis. The shrinkage is predictable thus can be compensated for during the design.

There are several methods available to create vias and microchannels on the ceramic tape. These methods include milling, punching, jet vapor etching and laser machining.

A 3 dimensional channel system may be designed by stacking several layers of the tape. The sidewalls of the channels may be coated with gold to form the electrodes for the magnetohydrodynamic pump.

FIG. 7 illustrates the use of a hole puncher to form channels and reservoirs in ceramic tape. FIG. 7 is an enlarged schematic diagram of the whole punching pattern used. Circular hole punch pattern 160 is used to form reservoirs in the tape. Straight hole punch pattern 162 is used to form a channel. By punching several holes in an overlapping manner, a channel and ring may be formed. FIG. 8 shows a top plan view of a piece of ceramic tape 170 that has had reservoirs 172 and channel 174 punched through it. Electrodes 176 are formed by screen printing conductive ink in a cross shaped pattern

over the channel as shown in FIG. 8. A vacuum is applied to the opposite side of the tape. This causes the ink to run down the sides of the channel and to separate so as to form two (2) electrodes. FIG. 9 is a cross sectional view of the same piece of tape shown in FIG. 8 along cross section line 178. FIG. 9 shows how electrodes 176 run along the inside of channel 174 on opposite walls. Excess conductive ink is pulled through channel 174 by the vacuum, so as to prevent channel 174 from being filled. By this method, 2 microelectrodes 176 are formed within the channel.

FIG. 10 shows the same piece of ceramic tape stacked with additional pieces of ceramic tape in order to form a microfluidic chip. Channel tape 170 shown in FIGS. 8 and 9 rest on top of support tape 180 and underneath via tape 182. Via tape 182 has holes filled with conductive material positioned such that they engage electrodes 176. Resting atop via tape 182 is top tape 184. Top tape 184 also has vias filled with conductive material. On the top side of tape 184 are catch pads 190. The catch pads are significantly larger than the extremely small vias 188. This is to facilitate connection to an electric current. Each catch pad 190 is connected to an electric current power source, such that one acts as an anode while the other acts as a cathode. Current travels from the catch pad through vias 188 down to electrodes 176. The current carrying species within the solution in channel 174 completes the circuit.

In this particular embodiment, the conductive material that the electrodes and catch pads are comprised of an that fill the vias is either gold or silver conductive ink. However, those skilled in the art will understand that any conductive material that is compatible with co-fired ceramic tape will be suitable.

All 4 pieces of ceramic tape have aligning holes 186. Proper alignment of these holes insures that the catch pads, vias and electrodes are aligned properly so that they may conduct electric current. Once the ceramic tape pieces have been fabricated and aligned, they are fired together to form a single solid chip. Prior to firing, the tape is flexible. However, once fired the chip structure becomes rigid. Because the chip is very thin, they may become brittle if there are an insufficient number of tape layers. Therefore, it is often desirable to include extra tape layers to strengthen the chip. FIG. 10 shows a chip having 4 layers. It is often more practical to form chips comprised of 10 or more layers to add strength and support. These additional layers may consist of additional support tapes, additional via tapes and/or additional channel tapes.

FIG. 11 shows a top down schematic diagrams of alternative chip configurations. The embodiment shown in FIG. 11 forms a microfluidic MHD channel having a feedback loop. Top plate 300 has reservoirs 302 that are connected by main channel 304. Main channel electrodes 306 and 308 are screen printed onto the ceramic tape such that they are connected to catch pads 310 and 312 respectively.

Reservoirs 302 and main channel 304 are formed by the manner shown in FIG. 7. Overlapping punch holes are used to form the pattern.

Catch pads 314 and 316 are screen printed such that conductive material connects them to vias 318 and 320 respectively. These vias are formed using the same hole puncher used to form the reservoir/channel design. Four aligning holes 322 are also punched into the tape. Second tape 380 has aligning holes 324 that correspond to aligning holes 322 in the top tape 300. Vias 326 and 328 are filled with conductive material and correspond to vias 318 and 320 respectively. Transport vias 330 correspond to reservoirs 320. These vias are left hollow so that the solution may pass through them.

Bottom plate 340 has alignment holes 332 that correspond to alignment holes 324 and tape 380 and to holes 322 and tape 300. Conductive pattern 334 is applied to bottom plate 340

such that via **326** is conductively connected to feedback channel electrode **342**. Similarly, conductive pattern **336** is applied to bottom tape **340** in such a way as to conductively connect via **328** to feedback channel electrode **344** when the 3 tapes are stacked. Feedback channel **346** is formed by making overlapping hole punches as shown in FIG. 7. Once all of the holes have been punched in the tape and the conductive material has been applied, the 3 tapes are stacked and co-fired. As with the previous example, it is often desirable to include several additional layers of tape in order to strengthen the final chip.

FIG. 12 shows an alternative embodiment of a microfluidic MHD channel designed to measure the volume of the analyte solution being analyzed. This embodiment is particularly well suited for keeping the analyte solution separate from the pumping solution. Analyte solution **208** is located in reservoir **210**. Electrodes **224** and **226**, in conjunction with a magnetic field applied to the structure **200**, causes analyte solution **208** to flow through introduction channel **218** and into main channel **215**. Main channel electrodes **220**, **232**, **234** and **222** are not active. Exit channel electrodes **228** and **230** are active and draw pumping solution **206** from the main channel **215** through the main channel **215** toward exit channel **216** by the vacuum caused by the pumping of the pumping solution **206** by electrodes **228** and **230**.

Once analyte solution **208** begins to enter the exit channel **216**, as shown in FIG. 13, introduction channel electrodes **224** and **226** and exit channel electrodes **228** and **230** are turned off. Main channel electrodes **220**, **222**, **232** and **234** are turned on to cause pumping solution **206** to enter the main channel **215** from reservoir **202** and to exit the main channel **215** into reservoir **214**. The movement of the pumping solution **206** causes the analyte solution **208** to travel down main channel **215** toward reservoir **214**, as shown in FIG. 14. Analysis of the analyte solution may occur at any point within the structure. In addition, other microfluidic channels may be added to main channel **215** or reservoir **214** and the analyte solution may be pumped through them.

The amount of analyte solution analyzed is determined by the distance between the introduction channel **218** and exit channel **216**. The distance between these two channels multiplied by the cross-sectional area of the channel equals the volume of analyte solution drawn into main channel **215**. FIG. 15 shows a microfluidic structure that operates in the same fashion as the structure shown in FIGS. 12, 13, and 14. However, in structure **400** introduction channel **404** and exit channel **406** join main channel **402** at the same point. This causes the portion of the analyte solution **408** that travels to reservoir **412** to be as small as possible. Pumping solution **420** propels analyte solution **418** down main channel **402**.

Pumping solutions **206** and **420** may be hydrophobic and analyte solutions **208** and **418** may be hydrophilic, or vice versa. This prevents the analyte solution from mixing with the pumping solution. Those skilled in the art will understand that there are advantages to keeping the analyte solution free of carrier species.

Other microfluidic pumping devices may be readily adapted for use in conjunction with a MHD system. The analyte solution may be introduced into the main channel using a different type of pumping. Once the analyte solution is within the main channel, an immiscible pumping solution may be used to propel the analyte solution through the structure.

The above embodiments describe a single channel with or without a second feedback loop. One embodiment describes a main channel and two side (introduction and exit) channels. However, those skilled in the art will appreciate that a natural

extension of these designs include a series of microfluidic channels, each utilizing the same magnetic field and each having independently addressable electrodes. These channels may be interconnected so that fluids may be propelled by Lorentz forces through more than one or all of them. FIG. 16 shows a piece of ceramic tape **500** having a number of microchannel structures. Microchannel **502** illustrates how a microchannel may have several branches, while microchannels **504**, **506**, **508**, **510** and **512** show a variety of different microchannel patterns.

FIG. 17 shows a series of pieces of ceramic tape **820**, **822**, **824**, **826** and **828**. These pieces of LTCC may be stacked and fired to form a ceramic chip capable of performing redox assays. Tape **820** has a gold electrode **832** stamped onto it in the form of gold ink. Gold ink circuit **834** extends away from electrode **832** and is aligned with vias that conductively connect it to a catch pad as described below. Electrode **832** will serve as the bottom of assay structure **902** as shown in FIG. 18.

Chip **822** has two holes that will serve as reservoirs punched through it, as well as filled via hole **840**. Hole **836** will form the bottom portion of a sample reservoir **898** in FIG. 18. Hole **838** will form part of assay structure **902**. Via **840** is filled with conductive, metallic ink.

Central tape **824** has hole **842** that in conjunction with hole **836** forms sample reservoir **898**. Similarly, hole **852** in conjunction with hole **838** forms assay structure **902**. Holes **842** and **850** are connected by conduit **848**. As can be seen in FIG. 18, conduit **848** is sandwiched between tapes **826** and **822** to form a magnetohydrodynamic conduit. Electrodes **844** and **846** are used to form an electric field within conduit **848** such that fluids having carrier species may be transported from sample reservoir **898** to assay structure **902**. Electrodes **850** and **856** are located on the sides of hole **852** and may serve as detecting electrodes within assay structure **902**. Exit conduit **854** allows a sample to be pushed out of assay structure **902**. Alternatively, conduit **854** exposes fluids within the microfluidic structure to the environment, thereby relieving back pressure. Filled via **870** allows electrode **832** to be connected to a catch pad.

Tape **826** consists of microfluidic conduits **858** and **868**, as well as filled vias **860**, **862**, **864**, **866** and **872**. These filled vias connect electrodes to catch pads on the top layer piece of tape **828**. Sample conduit **858** is part of conduit **904** that allows sample to be introduced into sample reservoir **898**. Conduit **868** allows conduit **854** to be exposed to the environment, thereby relieving back pressure for allowing sample to exit the microfluidic chip.

Top layer top **828** has hole **874** that completes conduit **904** and allows introduction of a sample into sample reservoir **898**. Similarly, hole **876** completes conduit **906**. Catch pad **878** is comprised of gold ink and lies directly above filled via **880**. Catch pad **878** is thereby conductively linked to electrode **832**. Catch pads **894**, **892**, **882** and **886** are similarly connected to electrodes **844**, **846**, **850** and **856** by filled vias **860**, **862**, **864** and **866** respectively. These catch pads allow current to be conductive to their respective electrodes. This facilitates MHD propulsion and detection of redox cycling.

The tape layer shown in FIG. 17 is layered as shown in FIG. 18 to form microfluidic assay chip **830**. Structure **830** is then fired so as to form the microfluidic assay chip. Aligning holes may be added to the tape layers, but is not shown here for clarity. Similarly, magnets are applied to the top and bottom of chip **830** to allow MHD propulsion through conduit **848**. The similar is not shown for clarity, but their positioning would be clear to one skilled in the art.

This relatively simplistic microfluidic assay chip **830** is operated in the following procedure. First, sample is introduced through conduit **904** into sample reservoir **898**. Sufficient sample is introduced such that some enters conduit **848** in between electrodes **844** and **846**. Because this assay is a redox assay, the sample being tested may also serve as a carrier species. An electric field is then applied to conduit **848** through electrodes **844** and **846** so as to induce MHD propulsion. In this manner, the sample will enter the assay structure **902**. Conduit **906** prevents the build up of back pressure. Leaving conduit **904** exposed to the environment also relieves back pressure. Due to the relatively small diameters of conduits **904** and **906**, the effects of evaporation are greatly reduced.

Once the sample enters assay structure **902**, redox cycling may be measured. Any combination of two of electrodes **850**, **856** and **832** may be utilized to measure redox cycling by cyclic voltammetry or other methods known in the art. In this embodiment, three electrodes are present within the assay structure and all three may be utilized. However, only two electrodes are necessary to perform redox cycling, as is well recognized by a skilled artist.

Those skilled in the art will appreciate that the concentration of a variety of redox compounds may be detected by the present invention. One particularly useful assay for use in the present invention is the detection of dopamine. Measuring low concentrations of dopamine has proven difficult because it is usually found in extracellular fluids that also include ascorbic acid in significantly greater concentrations. The chip described in FIG. **18** allows dopamine to constantly cycle between electrodes while ascorbic acid is irreversibly oxidized and censes contributing to electric current after a few seconds.

FIG. **19** shows a diagrammatic top view of a system designed for conducting an assay within a magnetohydrodynamically driven microfluidic system. The scheme in FIG. **19** may be used in microfluidic systems formed with either ceramic tape or photolithographic methods. The scheme of FIG. **19** may be punched or etched into a single layer that is then sandwiched between upper and lower layers.

Those skilled in the art will appreciate that FIG. **19** is one of many possible configurations for the assays disclosed herein and is therefore essentially a schematic diagram.

The sample **612** that is being analyzed is first placed in sample reservoir **604** by means of insert port **603**. This may be accomplished by a variety of methods including, but not limited to, injection by a syringe, using either a micro or macro scale pump and capillary action. If sample **612** is known to have a carrier species at a relatively high concentration, no carrier species will need to be added to facilitate MHD propulsion. However, it may be necessary to add an appropriate carrier species. It is also desirable that sample **612** have relatively low concentrations of salts. Although salts may assist MHD propulsion, they lead to rapid corrosion of electrodes. It may therefore be desirable to remove salts by precipitation or other methods known in the arts. Of course, if the microfluidic chip into which this assay is incorporated is intended to be a single use, disposable chip, corrosion of the electrodes is inconsequential.

Once sample **612** has been inserted into reservoir **604**, electric current is applied to electrodes **654** and **652** such that one is an anode and one is a cathode, thereby creating an electric field. Permanent magnets above and below structure **600** (not shown) provide a magnetic field. This causes sample **612** to flow through conduit **622**. Those skilled in the art will appreciate that one of the disadvantages of MHD propulsion is that it has slow flow rates. One of the advantages of using

MHD in microfluidic systems is that conduits through which fluids flow are relatively short. This allows even the slow flow rate of MHD to provide for rapid analysis. Sample **612** flows through conduit **622** into assay structure **602**. Those skilled in the art will appreciate that it may be possible to apply sample **612** directly to assay structure **602** without the need for sample reservoir **604** or conduit **622**. However, those skilled in the art will also appreciate that whichever structure, assay structure **602** or sample reservoir **604**, the sample is applied to will be exposed to the open environment and therefore subject to evaporation. Evaporation is a serious factor to consider with very small volumes. If assay structure **602** is not exposed to the environment, the concentration will remain constant. Therefore, it is often advantageous to utilize a separate sample reservoir. In addition, although not shown, those skilled in the art will appreciate that it is a relatively simple matter to add additional sample conduits to reservoir **604** that connect it to additional assay structures such that a variety of assays may be performed on a single sample.

Assay structure **602** has detecting electrodes **632** and **634**. In this particular embodiment, the MHD assay chip is formed on ceramic tape. Therefore, electrodes **634** and **632** are comprised of a metallic, conductive ink that is printed onto a layer of tape. Those skilled in the art will appreciate that if the microfluidic structure is formed using photolithographic techniques, it may be easier and more desirable to have detecting electrodes that are formed as tubular nanoband electrodes.

Primary analyte binding material **638** is located on either the top or the bottom (or both) of assay structure **602**. Analyte binding material **638** may be comprised of any of a variety of materials well known to those skilled in the art. In this particular embodiment, analyte binding material **638** is a primary antibody developed for an ELISA technique. In this particular embodiment, assay structure **600** is designed to detect the microorganism *Cryptosporidium parvum*. Therefore, ABM **638** is a primary antibody that is specific for *C. parvum*. It is attached to a self-assembled monolayer formed by lipids having a sulphate group on their hydrophilic ends. The sulphate group is covalently bound to gold ink printed on the ceramic tape layer that comprises the bottom of the assay structure **602**. Once sample **612** enters assay structure **602**, any *C. parvum* present will bind to ABM **638**.

Rinse reservoir **606** contains a rinsing solution **614**. Rinsing solution **614** may simply be DI water. Alternatively, solution **614** may be comprised of a series of buffers and/or salts and having a pH that optimizes the ELISA being performed. Additionally, rinse solution **614** has adequate concentration of a carrier species to facilitate MHD propulsion. A current is applied to electrodes **650** and **648** such that one serves as a cathode and one an anode. This in conjunction with permanent magnets above and below conduit **624** cause solution **614** to enter assay structure **602**. Conduit **624** has hydrophobic bead **630** in order to prevent premature mixing. Those skilled in the art will appreciate that hydrophobic bead **630** may not be necessary because of the relatively little mixing in a microfluidic system. Hydrophobic bead **630** is comprised of a hydrophobic liquid, such as an oil. It serves as a plug between conduit **624** and assay structure **602**.

Once sufficient time has elapsed for substantially all *C. parvum* present in sample **612** to bind to ABM **638**, solution **614** is propelled into assay structure **602** using MHD. Sample solution **612** and some of solution **614** exits assay structure **602** through conduit **636**. Conduit **636** may lead to a waste reservoir for discarded fluid. Alternatively, conduit **636** may lead to a second assay structure.



Once assay structure **602** has been rinsed by fluid **614**, solution **616** held in reservoir **608** is then introduced to assay structure **602**. In this embodiment, fluid **616** carries a secondary ABM, in this case a secondary antibody specific for *C. parvum* having an electroactive complex covalently attached. Solution **616** is located in conduit **626** between hydrophobic beads **633** and **631**. Beads **633** and **631** may be comprised of the same material as beads **630** in conduit **624**. **617** may be comprised of the same solution as **616** or may be a different solution. Almost any solution will be suitable for **617** so long as it has an adequate concentration of carrier species to facilitate MHD propulsion. When a current is passed through electrodes **646** and **644**, MHD propulsion of solution **617** is facilitated by the electric field and magnetic field provided by permanent magnets not shown. The presence of beads **631** and **633** prevents additional secondary ABM from entering assay structure **602** after excess secondary ABM has been rinsed out of assay structure **602**. Furthermore, because bead **631** is downstream of electrodes **644** and **646**, it is not necessary that solution **616** have a carrier species. This reduces the amount of carrier species present in assay structure **602** and helps to reduce background noise of electrochemical measurements. Beads **633** and **631** are not necessary for the present invention to function properly. However, they are generally preferred because they usually increase the accuracy of the invention. It is possible for reservoir **608** to hold solution **616** and for **616** to have a carrier species in it.

Once secondary ABM solution has entered assay structure **602** and sufficient time has been allowed for secondary ABM to attach to any *C. parvum* present, assay structure **602** is again rinsed with solution **614**.

This removes excess, unbound secondary ABM. The next step in the assay is to activate the electroactive complex. The method of activation will depend upon the type of electroactive complex used. Here, the electroactive complex is alkaline phosphatase. Therefore, activation of the electroactive complex consists of adding PAP to assay structure **602**.

Substrate reservoir **610** holds substrate solution **620** which contains PAP. Because PAP is a redox compound, it may also double as a carrier species for MHD propulsion. When a current is applied to electrodes **642** and **640**, the electric field in conjunction with the magnetic field produced by magnets above and below this structure cause substrate solution **620** to enter assay structure **602** by traveling down conduit **628**. As does conduits **624** and **626**, conduit **628** has a hydrophobic bead plug **635**. As with the other beads, this bead is not necessary but is preferred. Those skilled in the art will appreciate that although PAP is the substrate used for alkaline phosphatase, other electroactive complexes may require other substrates that may or may not be redox species. Solution **620** may be comprised of substrates or other activating compounds, such as a buffer that changes pH within the assay structure. As described above, some electroactive complexes are activated by change in pH. Activating species may also be a coenzyme or cofactor. Those skilled in the art will also appreciate that some electroactive species will not require the addition of a solution to be activated. In that situation, reservoir **610** and conduit **628** are unnecessary.

In this particular embodiment, assay structure **602** is rinsed by solution from reservoir **606** twice. Those skilled in the art will appreciate that this will also be accomplished by utilizing two reservoirs instead of one.

Once the electroactive species has been activated by addition of an activating compound or other means, current is run through electrodes **632** and **634**. Cyclic voltammetry or other current measuring methods may be utilized to evaluate the electrochemical activity of the contents of assay structure

**602**. The presence of two electrodes within the assay structure facilitates measurements of cyclic voltammetry and also facilitates redox cycling to amplify the electrochemical signal.

Those skilled in the art will appreciate that there will also be background noise. To evaluate background noise so that it may be subtracted from the signal received by electrodes **632** and **634**, it may be desirable to include a second control assay structure in a chip. A control assay structure would include all of the same features of microfluidic assay structure **600** except for the presence of primary ABM **638**. The process would be run simultaneously on the same sample. Sample for the control may be MHD driven from reservoir **604** or may have its own sample reservoir separate from structure **600**. In addition, due to the extremely small size of assay structure **600**, several such assay structures may be placed in an array or grid pattern on a chip. The array would include one or more controls as well as a variety of assays. Binding materials may be antibodies specific for other microorganisms or molecules. ABMs may also be DNA probes, protein substrates or other compounds having specificity. In addition, the primary ABMs located within the structure that cause an analyte to immobilize may alternatively be comprised of a binding material lacking specificity. Examples of this include polystyrene and nitrocellulose.

Assay structure **600** is designed such that electrodes **640**, **642**, **644**, **646**, **648**, **650**, **652** and **654** are all aligned such that they may all use the magnetic fluid from a pair of large magnets located above and below the electrodes. The magnets may be electromagnets, but permanent magnets are preferred in order to reduce energy consumption of assay chips. Because the electrodes are aligned, long, narrow magnets may be used thereby both simplifying manufacture and reducing the amounts of material needed. While it is preferred to utilize a structure that requires only a single, localized magnetic field, other configurations are possible. However, utilizing multiple magnetic fields unnecessarily complicates this device. When an array of assays are used, it would be desirable to align all the electrodes used for MHD propulsion either in a single long line or in a single region of the chip such that they may all use a single magnetic field. Electrodes **632** and **634** are not associated with MHD propulsion electrodes because they are used for measuring electric current and not for moving fluid within the microfluidic structure.

FIG. **20** shows a schematic diagram of an alternate embodiment of the present invention. Because MHD propulsion requires the presence of a carrier species, substantial additional background noise often results in electrochemical measurements of assays. This is because carrier species by their nature are capable of redox cycling. This can make electrochemical measurements more difficult at low analyte concentrations. To overcome this, the present invention has described the techniques shown in FIGS. **12** through **15**. FIG. **18** shows how those techniques could be applied for use in small scale assays. This improves the sensitivity of the assays. The structure or method is very similar to that described in FIG. **19**. The significant difference between the diagrams shown in FIGS. **19** and **20** is that FIG. **20** employs "hydrophobic pumps" to inject the sample, secondary ABM solution, rinse solution and activating solution into the assay structure.

Sample solution **663** is placed into sample solution reservoir **662**. This may be accomplished in the same methods by which sample solution **612** is placed in reservoir **604** of FIG. **19**. However, the microfluidic assay structure **660** of FIG. **18** requires that once sample solution **663** is placed in reservoir **662**, reservoir **662** must be sealed hermetically. If reservoir

662 is not sealed properly, then activation of hydrophobic pump 675 will result in a substantial portion of the sample to exit through entry port 661. This may be accomplished by partially filling port 661, thereby blocking it, or by placing some sort of seal over port 661.

Once reservoir 662 is no longer exposed to the outside environment, hydrophobic pump 675 is actuated. This is accomplished by applying current to electrodes 730 and 731 such that an electric field is formed between them. Permanent magnets (not shown) above and below conduit 684 create a magnetic field in approximately the same region as conduits 684 to which electrodes 730 and 731 apply an electric field. Pump reservoir 676 is filled with pump fluid 677. Pump fluid 677 is hydrophobic. Hydrophobic solutions may be comprised of any hydrophobic compound so long as it is liquid at room temperature and is capable of dissolving a carrier species. Those skilled in the art will appreciate that there are a variety of organic redox cycling compounds that are soluble in hydrophobic solutions. Various compounds used in cellular respiration within mitochondrial membranes are well suited to be these carrier species. When electric current is applied to electrodes 730 and 731, Lorentz forces induce MHD propulsion of the hydrophobic fluids. This pushes the aqueous sample from sample reservoir 662 down conduit 668 and into assay structure 664. Once sufficient sample has entered assay structure 664, the electrical current is ceased and the hydrophobic pump is thereby deactivated. As with the system described in FIG. 19, the assay structure 664 has a primary ABM on its bottom and attached to the underlying piece of ceramic tape. However, in the assay described in FIG. 20, the primary ABM is a DNA probe. It is covalently bound to the hydrophobic end of a lipid that is part of a self-assembled monolayer which is, in turn, covalently bound on its hydrophilic end to a metal surface. The DNA probe is complementary to an analyte polynucleotide strand.

In this particular embodiment, the assay is designed to perform a hybridization assay. It is therefore desirable to include heating element 669 which is attached to reservoir 662. The heating element heats the sample solution, thereby denaturing double stranded DNA. While it is preferred to have heating element 669, it is not necessary. It is possible to heat and denature the sample prior to placing it within reservoir 662.

Once sufficient time has been given for any analyte DNA to anneal to the primary ABM probe, it is rinsed by rinse solution 714 which is stored in reservoir 670. Reservoir 670 has a hydrophobic pump attached to it by means of piston conduit 866. Pump reservoir 678 has a hydrophobic solution 720 having a dissolved carrier species within it. This pump operates in the same way as pump 675. An electric current is applied to piston conduit 866 by electrodes 698 and 700. This works in conjunction with a magnetic field to cause solution 720 to move towards reservoir 670 and act as a piston within conduit 866. This, in turn, pushes rinsing solution 714 down conduit 685 and into assay structure 664. Conduit 685 has a hydrophobic bead 713 to serve as a plug so that rinsing fluid 714 does not leak into assay structure prematurely. As with the hydrophobic plugs in FIG. 19, this plug is not necessary but is preferred. Once rinsing fluid 714 has flushed assay structure 664 of the sample, the electric field generated by electrode 698 and 700 is ceased so as to stop the pumping action.

Rinsing fluid 714 may be comprised of deionized water. Because Lorentz forces are not applied to solution 714 itself, it has no need for a carrier species. This is generally preferred as it does not introduce any compounds that may produce background noise to the structure 664.

Reservoir 672 has solution 712 in which a secondary ABM, in this case a secondary probe, is dissolved. The secondary ABM probe has a carrier species covalently bound to it. Once the rinsing step is completed, electric current is applied to electrodes 702 and 704 to create an electric field through piston conduit 688. Hydrophobic solution 718 has a carrier species dissolved within it and is kept in reservoir 680. An electric field is applied that works conjointly with a magnet to push solution 718 down piston conduit 714 to work as a piston and push solution 712 out of reservoir 672, down conduit 686 and into assay structure 664. Solution 712 may also be comprised of buffers and/or salts and/or chelating agents and other compounds known to those skilled in the art to enhance the hybridization process. Once sufficient quantities of solution 712 have entered assay structure 664, the electric current applied to electrodes 702 and 704 is ceased and pumping action stops. As with the other plugs described herein, hydrophobic bead 713 is not necessary but is preferred. This microfluidic assay structure also shows that it is not necessary to have a second bead in the conduit that introduces the secondary ABM.

After sufficient time has been allowed for the secondary ABM to bind to any analyte DNA present, assay structure 664 is again rinsed by rinse solution 714. As with the initial rinse, addition of rinse solution 714 to assay structure 664 is facilitated by applying current to electrodes 698 and 700, thereby actuating a hydrophobic pump. The electric current is ended after assay structure 664 is sufficiently rinsed.

Once excess secondary ABM is removed from assay structure 664, it may be necessary to add an activating agent and activating solution 710. In this particular embodiment, the electroactive species is again alkaline phosphatase. Therefore, PAP must be added to serve as a redox cycling compound to facilitate detection. Activating solution 710, stored in reservoir 674, is pushed by hydrophobic pump solution 716, stored in reservoir 682, when an electrical field is generated by electrodes 706 and 708. Hydrophobic solution 716 moves down pump conduit 690, thereby pushing solution 710 down conduit 687 and into assay structure 664. As with other conduits, hydrophobic bead 711 prevents premature mixing of the activating solutions. Once the activating solution is added, electrodes 724 and 726 are used to measure currents generated by any alkaline phosphatase present.

As with the assay described in FIG. 19, the electroactive complex utilized in the assay described in FIG. 20 may not require an activating agent.

FIGS. 19 and 20 disclose only two of a wide variety of immobilization assays. They are intended to illustrate methods by which immobilization assays may be incorporated into microfluidic systems to quickly, efficiently and easily perform assays on a wide variety of samples and analytes. They may be used in conjunction with each other and may be combined in a variety of ways. One such combination is shown in FIG. 21.

FIG. 21 shows a method of performing two assays in sequence using a microfluidic structure. Reservoirs 816 are actuated to deposit solutions into assay structures 806 and 809 by hydrophobic pumps 812 in the same methods described above. Assay structure 806 is designed to perform an ELISA substantially the same as that described above. Assay structure 806 is designed to perform an ELISA substantially the same as that described in FIG. 19. Those skilled in the art will appreciate that the modifications are slight. Assay structure 806 has heating element 810 attached to it. After the ELISA is completed, heating element 810 is actuated in order to heat shock immobilized microorganisms. The heat shock results in release of heat shock mRNAs. The

21

solution in assay structure **806**, now including heat shock mRNAs is pumped down conduit **807** and into assay structure **809**. Assay structure **809** is substantially the same as that described in FIG. **18**. It is used to detect the presence of any heat shock mRNAs. This combination of assays allows a microfluidic chip to rapidly and accurately detect not only the presence but also the viability of the microorganism for which it is testing. As with the assay structures disclosed in FIGS. **17** and **18**, the structure disclosed in FIG. **19** may also be used to form an array of similar structures on a chip. Even relatively large assay structures, such as the one disclosed in FIG. **21**, take up only a few millimeters on a chip.

Microfluidic assay systems disclosed in FIGS. **17** through **21** are intended to illustrate their use when comprised of ceramic tape. Those skilled in the art will appreciate that similar structures are readily formed by photolithographic methods. In addition, reservoirs and assay structures are all depicted as being circular in shape. Those skilled in the art will appreciate that they may take on any of a variety of forms. Similarly, conduits are all shown to be substantially straight. Those skilled in the art will appreciate that these conduits may be curved. The assay structures have also been shown to exist two dimensionally. Those skilled in the art will appreciate that both ceramic tape chips and photolithographic chips are comprised of several layers. The reservoirs and assay structures may be comprised of one or several layers. In addition, it is not necessary that an assay system in a microfluidic chip have a planar design. In many situations, it may be desirable for the microfluidic assay system to utilize reservoirs from many different layers within a chip. Similarly, conduits may readily be designed to penetrate several layers. Those skilled in the art will appreciate that the microfluidic assay designs schematically depicted in FIGS. **17** through **21** may be readily adapted to a large variety of three dimensional geometries.

For clarity, the magnets used to create the magnetic field are not shown in FIGS. **17** through **21**. However, those skilled in the art will appreciate that a magnetic field is readily applied to the structures by placing a pair of magnets about them. One magnet would go above the structure and one below, both being laid at the location corresponding to points where MHD electrodes are placed along conduits.

Whereas, the present invention has been described in relation to the drawings attached hereto, it should be understood that other and further modifications, apart from those shown or suggested herein, may be made within the spirit and scope of this invention.

What is claimed is:

1. A method for constructing a magnetohydrodynamic microfluidic device, comprising the steps of:
  - fabricating at least one channel layer using at least one layer of ceramic;
  - forming at least two electrodes in at least one channel and substantially perpendicular to said at least one channel;
  - forming at least one magnet in said at least one channel and substantially perpendicular to said channel and said electrodes;
  - inserting said at least one channel layer between at least two sandwiching layers to form a unitary device;
  - forming electrical connectors such that current or voltage can be applied to said electrodes; and
  - applying said magnet and said electrodes substantially perpendicular to a solution within said at least one channel causing said solution to flow through said at least one channel.
2. The method for constructing a magnetohydrodynamic microfluidic device according to claim **1** including an addi-

22

tional step of laminating said at least one channel layer between said sandwiching layers.

3. The method for constructing a magnetohydrodynamic microfluidic device according to claim **2** wherein said step of laminating is accomplished by pressure, thermal or adhesive means.

4. The method for constructing a magnetohydrodynamic microfluidic device according to claim **1** wherein said at least one layer of ceramic is a low-temperature, co-fired ceramic material or a high-temperature ceramic material.

5. The method for constructing a magnetohydrodynamic microfluidic device according to claim **1** wherein at least one of said sandwiching layers is ceramic, glass or a polymer.

6. The method for constructing a magnetohydrodynamic microfluidic device according to claim **5** wherein said ceramic of said at least one of said sandwiching layers is a low-temperature, co-fired ceramic material or a high-temperature ceramic material.

7. The method for constructing a magnetohydrodynamic microfluidic device according to claim **1** wherein said step of forming electrical connectors is accomplished by fabricating circuits onto said at least one channel layer such that said circuits allow current or voltage to be applied to said electrodes.

8. The method for constructing a magnetohydrodynamic microfluidic device according to claim **7** wherein said step of fabricating circuits onto said at least one channel layer is by screen printing, thermal deposition, sputter deposition, electron-beam deposition, laser ablation, photolithography, electro-plating or electroless-plating processes.

9. The method for constructing a magnetohydrodynamic microfluidic device according to claim **1** wherein said step of forming electrical connectors is accomplished by fabricating circuits onto at least one of said sandwiching layers such that said circuits allow current or voltage to be applied to said electrodes.

10. The method for constructing a magnetohydrodynamic microfluidic device according to claim **9** wherein said step of fabricating circuits onto said at least one of said sandwiching layers is by screen printing, thermal deposition, sputter deposition, electron-beam deposition, laser ablation, photolithography, electro-plating or electroless-plating processes.

11. The method for constructing a magnetohydrodynamic microfluidic device according to claim **1** wherein said electrodes are fabricated by screen printing, thermal deposition, sputter deposition, electron-beam deposition, laser ablation, photolithography, electro-plating or electroless-plating processes.

12. The method for constructing a magnetohydrodynamic microfluidic device according to claim **1** wherein said electrodes are fabricated into spatially separate bands, disks, rectangles, or other geometric shapes to which electrical current or voltage can be individually applied.

13. The method for constructing a magnetohydrodynamic microfluidic device according to claim **1** wherein said electrodes are fabricated using continuous conductive material or nanoparticulate material.

14. The method for constructing a magnetohydrodynamic microfluidic device according to claim **1** wherein said electrodes are formed using pull-through methods.

15. The method for constructing a magnetohydrodynamic microfluidic device according to claim **1** wherein said electrodes are formed by coating both sides of said at least one channel layer and using pull-through methods.

16. The method for constructing a magnetohydrodynamic microfluidic device according to claim **1** including the addi-

23

tional step of fabricating passive equilibration conducting walls within said at least one channel.

17. The method for constructing a magnetohydrodynamic microfluidic device according to claim 16 wherein said passive equilibration conducting walls are constructed of continuous conductive material or nanoparticulate material.

18. The method for constructing a magnetohydrodynamic microfluidic device according to claim 16 wherein said passive equilibration conducting walls are fabricated by screen printing, thermal deposition, sputter deposition, electron-beam deposition, laser ablation, photolithography, electroplating or electroless-plating processes.

19. The method for constructing a magnetohydrodynamic microfluidic device according to claim 16 wherein said passive equilibration conducting walls are fabricated into spatially separated bands, disks, rectangles, or other geometric shapes.

20. A magnetohydrodynamic microfluidic device, comprising:

at least one channel layer using at least one layer of ceramic;

at least two electrodes in at least one channel and substantially perpendicular to said at least one channel;

at least one magnet in said at least one channel and substantially perpendicular to said at least one channel and said electrodes;

wherein said at least one channel layer is between at least two sandwiching layers to form a unitary device; and

wherein said electrodes and said magnet induce a solution to flow in a direction substantially perpendicular to both said electrodes and said magnet.

21. The magnetohydrodynamic microfluidic device of claim 20 wherein said at least one channel layer is laminated between said sandwiching layers.

22. The magnetohydrodynamic microfluidic device of claim 21 wherein said lamination of said at least one channel layer between said sandwiching layers is accomplished by pressure, thermal or adhesive means.

23. The magnetohydrodynamic microfluidic device of claim 20 wherein at least one of said sandwiching layers is ceramic, glass, or a polymer.

24. The magnetohydrodynamic microfluidic device of claim 23 wherein said ceramic of said at least one of said sandwiching layers is a low-temperature, co-fired ceramic material or a high-temperature ceramic material.

25. The magnetohydrodynamic microfluidic device of claim 20 wherein said at least one layer of ceramic is a low-temperature, co-fired ceramic material or a high-temperature ceramic material.

26. The magnetohydrodynamic microfluidic device of claim 20 further including electrical connectors wherein said electrical connectors allow current or voltage to be applied to said electrodes.

27. The magnetohydrodynamic microfluidic device of claim 26 wherein said electrical connectors are formed by

24

fabricating circuits onto said at least one channel layer such that said circuits allow current or voltage to be applied to said electrodes.

28. The magnetohydrodynamic microfluidic device of claim 27 wherein said fabrication of said circuits onto said at least one channel layer is by screen printing, thermal deposition, sputter deposition, electron-beam deposition, laser ablation, photolithography, electro-plating or electroless-plating processes.

29. The magnetohydrodynamic microfluidic device of claim 26 wherein said electrical connectors are formed by fabricating circuits onto at least one of said sandwiching layers such that said circuits allow current or voltage to be applied to said electrodes.

30. The magnetohydrodynamic microfluidic device of claim 29 wherein said fabrication of said circuits onto said at least one of said sandwiching layers is by screen printing, thermal deposition, sputter deposition, electron-beam deposition, laser ablation, photolithography, electro-plating or electroless-plating processes.

31. The magnetohydrodynamic microfluidic device of claim 20 wherein said electrodes are in spatially separate bands, disks, rectangles, or other geometric shapes to which electrical current or voltage can be individually applied.

32. The magnetohydrodynamic microfluidic device of claim 20 wherein said electrodes are fabricated by screen printing, thermal deposition, sputter deposition, electron-beam deposition, laser ablation, photolithography, electroplating or electroless-plating processes.

33. The magnetohydrodynamic microfluidic device of claim 20 wherein said electrodes are constructed of continuous conductive material or nanoparticulate material.

34. The magnetohydrodynamic microfluidic device of claim 20 wherein said electrodes are formed using pull-through methods.

35. The magnetohydrodynamic microfluidic device of claim 20 wherein said electrodes are formed by coating both sides of said at least one channel layer and using pull-through methods.

36. The magnetohydrodynamic microfluidic device of claim 20 further including passive equilibration conducting walls within said at least one channel.

37. The magnetohydrodynamic microfluidic device of claim 36 wherein said passive equilibration conducting walls are constructed of continuous conductive or nanoparticulate materials.

38. The magnetohydrodynamic microfluidic device of claim 36 wherein said passive equilibration conducting walls are in spatially separate bands, disks, rectangles, or other geometric shapes.

39. The magnetohydrodynamic microfluidic device of claim 36 wherein said passive equilibration conducting walls are fabricated by screen printing, thermal deposition, sputter deposition, electron-beam deposition, laser ablation, photolithography, electro-plating or electroless-plating processes.

\* \* \* \* \*