

5-2014

Water System for Developing Countries / Disaster Relief Made with Local Materials

Lauren E. Cole

University of Arkansas, Fayetteville

Follow this and additional works at: <http://scholarworks.uark.edu/cheguht>

Recommended Citation

Cole, Lauren E., "Water System for Developing Countries / Disaster Relief Made with Local Materials" (2014). *Chemical Engineering Undergraduate Honors Theses*. 75.
<http://scholarworks.uark.edu/cheguht/75>

This Thesis is brought to you for free and open access by the Chemical Engineering at ScholarWorks@UARK. It has been accepted for inclusion in Chemical Engineering Undergraduate Honors Theses by an authorized administrator of ScholarWorks@UARK. For more information, please contact scholar@uark.edu.

This thesis is approved.

Thesis Advisor:

Christa Hestekle

Thesis Committee:

An Undergraduate Honors College Thesis

in the

College of Engineering
University of Arkansas
Fayetteville, AR

by

Personal Contribution to This Paper

At the beginning of this project, I elected to focus mainly on the electrolysis portion. I completed a lot of research on electrolysis in general, and then specifically on brine electrolysis, which is transforming a salt water solution into a sodium hypochlorite solution, or bleach. I researched all of the different types of electrode materials and purchased several electrodes in order to perform experiments. I researched several methods of electrolysis in use today.

I performed several calculations about the electrolysis reaction, including the electric potential required to drive the reaction (approximately 1.0 volt), as well as what concentration of salt to use for the water and the expected final concentration of the bleach solution that would be created. Based on sources given to us in the Phase I proposal, a salt concentration of 3% by weight was chosen, and this translates to a 0.513M solution. Due to the stoichiometry, this indicates that the highest concentration of sodium hypochlorite solution that was possible was also a 0.513M solution. Based on the electric potential, I ranked what I thought would be the best pairings of electrodes, and I planned how to carry out the experiment. The “best” theoretical pairing of electrodes was the copper and aluminum pairing, because the potential difference between the two metals was the highest, at 2.01 volts. After that failed, I purchased new electrodes with special coatings that were already in use for this type of application and carried out experiments with these electrodes.

I performed every electrolysis experiment, recorded data, and drew conclusions about the data I recorded. I determined what the optimal time to run electrolysis was based on the batch size we selected. I took the graphs depicting the data from the treadle pump, sand filter, battery charging, and electrolysis experiments, edited them, and inserted them into the final paper. Although many group members assisted in writing the paper, I went through it and meticulously edited it for both content and grammar. I also filmed the footage we needed for the instructional videos.

I assisted with the overall design of the water purification system, including what materials to use, what the size of batches should be, and how we would keep the water clean in the final reservoir. I spoke with a Civil Engineering professor regarding how clean the water must be to kill the microbes we expected to be present in the non-potable water, and we decided to use a chlorine residual of 1-5ppm based on her recommendation. I also spoke with two

Chemical Engineering professors to learn more about the electrochemistry of the electrolysis reaction and to consult when I was having problems with the experimentation.

I assisted in doing research in other areas of the project, including discrediting the idea of using a scotch yoke, and coming up with an alternative plan. I investigated the use of an alternator to charge the 12 volt battery using a bicycle, and when that failed, I researched about using the DC motor from a scooter to charge the battery using a bicycle.

Water System for Developing Countries / Disaster Relief Made with Local Materials

Faculty advisors: Christa Hestekin, Roy Penney, and Stephanie Schulte

Student team: Lauren Cole, Keiron Durant, Jordan Goss, Shumon Hasan, DJ Lee, Omar Qasem, Florencio Serrano Castillo, and Cayla Tichy

IV. EXECUTIVE SUMMARY

Date of Project Report: March 25, 2014

EPA Agreement Number: SU835531

Project Title: Water System for Developing Countries / Disaster Relief Made with Local Materials

Faculty Advisors: Hestekin, Christa; Penney, Roy; Schulte, Stephanie

Student Team Members: Cole, Lauren; Durant, Keiron; Goss, Jordan; Hasan, Shumon; Lee, DJ; Qasem, Omar; Serrano Castillo, Florencio; Tichy, Cayla

Department and Institution: Ralph E. Martin Department of Chemical Engineering, University of Arkansas

Project Period: 8/15/2013 - 8/14/2014

Description and Objective of Research

The United Nations estimates that water-borne illness accounts for 80% of deaths in developing nations and that nearly 1 in 6 do not have access to clean water (1). However, despite the ability to produce water in the developed world from complex streams such as wastewater or seawater, challenges remain in providing this basic resource in the developing world. Too often the approach has been to apply a high-tech solution, which requires significant technical expertise to run and significant financial resources to repair. Furthermore, as every developing nation faces different challenges, a new solution must be provided for each situation.

The objective of this project was to design a water purification system that can be constructed from easily available materials, common to the particular country, and is capable of the complete water purification process. The designed system consisted of a treadle pump (built from wood or bamboo) to pull the water from its source, a filter (made of readily available materials such as sand) to remove contaminants and improve palatability of water, an electrolysis system to allow chlorination from salt water (using locally sourced salt), and a car battery (which could be sourced from a scrapped car) that could be charged by pedaling a mountain bike connected to a DC motor (which could be obtained from a scrapped scooter). In addition, a set of instructions was developed that can be interpreted with minimal text. In Phase I, a working model and the schematics of the system were developed and tested. In Phase II, the schematics will be taken to a developing nation, India, and a water purification system will be built and evaluated on site. The schematics will be modified according to the ability of locals to understand and construct the system and schematics will be developed for other developing nations with different material resources. Depending on the success of the project, additional funding will be requested to distribute these instructions to as many developing nations as possible.

The Phase I research team, Team WaterHOGs, sought to design a simple water purification process that would clean water from alternate sources. One innovation of this system was the novel combination of previously demonstrated technologies into one system that can take water from untreated non-potable water to drinking water. Another unique innovation was

the development of a set of instructions that could be used anywhere in the world with locally sourced materials and with minimal use of text. Due to the nature of this technology, the water source must be freshwater (i.e. no ability to turn seawater into drinking water) and chemical contaminants (i.e. PCBs, heavy metals) will not be removed. A higher tech approach would be able to handle seawater (i.e. reverse osmosis system or solar distillation), but at the cost of higher material and energy costs. Since most of the developing nations are dealing with water contaminated with fecal matter, the technology is focused on eliminating microbial contaminants (2). In addition, low technology solutions often provide a longer lasting and less waste-producing solution (3).

Summary of Findings (Outputs/Outcomes)

Water Assessment

Team WaterHOGs first sought to determine what types of water compositions the intended process could handle. Through extensive research it was determined that the system should be primarily targeted towards water supplies contaminated with microbial agents, but with moderate levels of salinity, and no chemical contaminants.

Treadle Pump

The single person treadle pump was constructed primarily using standard 2”x 4” wooden beams. The piston system was built from standard 4 inch diameter PVC pipe. A support system was designed, using additional 2”x 4” wooden beams to stabilize the main structure of the pump, and minimize friction losses. The final pump used two pistons and was capable of producing 12 psia of head per piston when operated by a 160 lb person. This generated a flow rate of 5 gallons per minute. The wooden beams and PVC pipe could be replaced with local materials such as bamboo.

Sand Filter

A sand filter was designed to removed large contaminants and other suspended solids present in the well water. The filter was designed using an 18 gallon plastic bucket open to the atmosphere. The filter contained layers of sand, coarse gravel and cloth. The water was pumped into the top of the filter using a single piston, where it flowed down the filter material, and was collected at the bottom of the bucket through a two inch PVC tube connected to the second piston. Theoretical analysis and experimentation confirmed that the pressure head and volumetric flow rate are not significantly affected after the water flows through the filter. The PVC pipe and plastic bucket could be replaced with local materials such as bamboo and pottery.

Electric Generator

In order to obtain the energy required to power the entirety of the process, Team WaterHOGs designed a human powered electric generator. The generator was built from an 18 speed mountain bike, which was hooked up to a DC motor. This motor was attached to a 12 volt

car battery; as long as the bicycle was being pedaled fast enough (>1000 rpm), the battery will be charged. This battery was used to power the electrolysis unit. Testing confirmed the ability of this system to recharge the battery. The DC motor could be obtained as scrap from a broken scooter while the bike could be any that would achieve the appropriate rpm.

Electrolysis Unit

An electrolysis unit was designed to operate in a batch system and produce sodium hypochlorite (bleach) solution from salt water. The original salt solution used was 30 g/L, or a 3% by weight solution, and the 12 volt car battery was used to power the system. Electrodes made from several metals were tested, but a titanium cathode and a ruthenium oxide coated anode were selected as the most successful pair due to no significant corrosion over time. Testing proved the ability of the cell to produce enough bleach at a reasonable rate to service the water needed on a given work day. Local pottery could be used to make the electrolysis container. The electrodes used in our system are the only items that could not be obtained from a scrap or local material. While cheaper electrode materials were capable of producing sodium hypochlorite, the reactions time required was longer and there was more corrosion.

Visual Instruction for the General Public

One of the main objectives of the project was to make the results as accessible as possible. This is particularly important given the target audience, rural communities in third world countries. In order to accomplish this objective, Team WaterHOGs developed a set of pictorial instructions that conveys the assembly process of each separate unit, as well as the system as a whole. These instructions are designed so that no minimum level of education or technical background is needed for their execution. The current instructions are available in both English and Hindi (see supplementary materials) and are still in the process of being reduced to minimal language. These instructions are also available on the PI's website (<http://comp.uark.edu/~chesteki/index.php>).

Conclusions

Phase I proved the feasibility of designing and building a working water purification system with minimal cost and limited materials. These types of systems, while simplistic, provide a valuable opportunity for a low cost, sustainable method of water purification in developing nations. By measuring chlorine levels the team was able to determine that the water would be free of microbial contaminants and therefore safe to drink.

The designed system can provide 1,500 gallons of clean water per day to a village using two person manpower during an 8-hour workday. The recommended amount of water usage for drinking, sanitation, bathing, and cooking is about four gallons per person per day so this system would sustain a population of about 375 people (4).

Based on Phase I research, it is expected that this system would be successful should it be implemented during Phase II. Experimentation carried out by the team on the individual system

components demonstrated the ability to pump enough water, to filter the water to reduce turbidity and remove particulates, to produce enough sodium hypochlorite (bleach) for microbial disinfection, and to produce enough electricity to power the electrolysis which produces the bleach. Further testing regarding the performance of the equipment after extended, continuous usage might be necessary. This would be critical in order to develop optimized logistic protocols for both the construction and operation of this system. Therefore, field research centering around the implementation and operation of multiple units in developing nations is highly recommended. Phase II proposes to do this by working with a university in India and implementing the system in key villages in their area.

Proposed Phase II Objectives and Strategies

In Phase II, senior chemical engineering students will travel to India and work with locals to build the full scale process capable of producing 1,500 gallons of palatable, potable water per day. This is made possible with the cooperation of Christ University in India (see Bryan Hill letter of support). The materials required to build the water purification unit would be purchased or found in India. The construction of the entire process is estimated to cost less than \$500.

The construction process will be completed by locals as much as possible, with the Phase II team assisting and modifying for future implementation. This will provide the team of students with feedback to correct the schematics where there is confusion. Additionally, before the visit a video will be created showing the construction of each step in the process. This will be shown to the locals before they begin construction to give a better understanding of the process.

After the system has been built and implemented, a team of students will return to the site. They will check to see if the system is still in place and if there are any modifications that have been made by the locals. For example, the locals might choose to replace the electrolysis unit with bleach depending on its cost and availability. In addition, any modification that the locals have made to the system may be used to make modification in the instructions as well as for the potential development of a set of maintenance instructions. The students will also check the contamination level of the water. This will be used to assess the effectiveness of the design and any modifications need before implementation in other developing countries.

Supplemental Keywords: Water treatment, water purification, developing countries, electrolysis, filtration, bleach, treadle pump

Relevant Websites: <http://comp.uark.edu/~chesteki/index.php> (for downloading instructions)

Summary of Phase I Results

1. Background and Problem Definition

Relevance and Significance to Developing or Developed World

Access to clean, safe drinking water is vital to human life and health. However in many developing nations, poor or remote communities have problems with water that is contaminated with fecal matter containing microbial pathogens. Because of the nature and location of these communities, a water purification system needs to be inexpensive and sustainable. In Phase 1, we have designed and constructed a water purification system that is capable of pumping and disinfecting 1,500 gallons per day at a cost of <\$0.01 per gallon. This system consists of a treadle pump, sand filter, electrolysis system, and bicycle battery charger. The system is inexpensive because the majority of parts can be made from local materials (bamboo or pottery) or obtained from scrapped materials (car battery, DC motor from scooter). In addition, a set of instructions requiring limited education and technical abilities will allow the communities to build the water purification systems themselves therefore taking ownership and operation of the system to increase the sustainability of the process.

Relationship to People, Prosperity and the Planet

In Phase I, a system was designed and built that has the potential to provide 1,500 gallons per day of clean water and requires one person operating the treadle pump for about eight hours and a one person pedaling a mountain bike for approximately nine hours to charge the batter to power the electrolysis unit. The recommended amount of water usage is about four gallons per person per day (4), so this system would sustain a population of 375 people.

The designed system seeks to supply a low-cost, low-technology, accessible water purification system capable of supplying local communities with enough water for daily activities with minimal capital investment or maintenance required. It is important to notice that the expected outcome of this project was crafted to mimic those suggested by the EPA's Local Government Climate and Energy Strategy Series (5). These guides outline simple methods geared for the development of energy-saving measures for the day-to-day operations of small rural communities, while still satisfying the basic needs of the population. It was believed that these guidelines could be altered and refocused to fit the needs of small rural communities in the developing world as well. To accomplish this, stricter design considerations were set that would account for more limited resources. For example, it was assumed that there would be no access to electricity and a limited access to non-locally produced materials. Goals in the project have been completed by implementing concepts like *Smart Growth*, a set of strategies used to encourage development that serves the communities, and their social conscience towards themselves and the environment (6).

Implementation of the P3 Project as an Educational Tool

Team WaterHOGs includes seven senior chemical engineering students and one junior

communications student. The chemical engineering students will be given course credit for Design II (with the option to use this project for their Honors thesis) and they have performed the literature searches on equipment design, preliminary testing, and construction of the water treatment system. This P3 project more than satisfied the base requirements of the engineering capstone design course, which includes the understanding and application of key chemical engineering techniques like energy and mass balances, process flow diagrams, design, scaling-up, costing, and economic analysis. The communications student was a vital, integrated part of this team as she took the engineering design and dissected it into a set of instructions that could be understood by people with lower education levels, such as those in developing nations. This required the engineering students to explain to the communications student how to build the system; the communications student had to take this explanation and convert it into an understandable set of instructions. The communications student will receive course credit for independent study in communications and the ability to use the project for her Honors thesis.

2. Purpose, Objectives, Scope

The purpose of Phase I was to develop, test, and assess the design for a water purification process that would allow rural communities in developing nations to source their own water. A *Nature* review article reported that many of the infectious diseases re-emerging around the world are originating in developing countries, and can be attributed to unsanitary conditions (7). Furthermore, the UN predicts that by the year 2050, roughly 85% of the global population will be located in the developing world (8). Therefore, a proactive approach to this population shift is needed. Technology like the one proposed here seeks to educate as it helps. Its adoption could help prepare developing countries for potential fluctuations in the demand for resources, prices, or even population shifts. This type of system effectively allows communities to become independent and self-reliant, having wide reaching effects past the few communities helped directly during Phase II. It is also important to notice that systems like these could also be used in disaster relief situations in hard to reach areas, where basic necessities like clean water and power are not accessible.

An important objective of this project was to provide a system that can accomplish the previously stated goals at a price not only affordable, but significantly lower than more mainstream water purification processes. To accomplish these goals, Team WaterHOGs has ensured that the system could be successfully implemented in most communities, and that design alternatives could be easily incorporated based on the local availability of materials. Lack of traditional building materials or access to trained labor would not be a detriment for the success of the project. The treadle pump can be built with virtually any type of wood or strong plant-based material available; the electrolysis unit and generator can be made from parts found in salvage yards. It is estimated that after one year of operation, the cost of water is approximately \$0.28/day (< \$0.01/gallon).

One of the most significant aspects of this project is the design of the instructions for the construction of the water purification system. These schematics were designed to be simple to

understand, access, and modify according to specific needs. The PI's website will be used as a repository for these instructions that will also include modifications as they become available. The instructions will be downloadable so that developing nations or groups assisting them can use the instructions as a blueprint to implement the system. At the completion of Phase II, Team WaterHOGS will have overseen the construction of field units in communities in India, as well as monitored these systems to ensure that they operate at a safe and environmentally friendly level.

3. Data, Findings, Outputs/Outcomes

Figure 1 is a process flow diagram of the entire water purification system. Untreated water enters the treadle pump (P-101). This pump has two pistons; one piston draws the water from the underground well and deposits it in the sand filter (V-101). The other piston draws up the filtered water from the sand filter unit and pumps it into one of three 100 gallon drums (V-102, V-103, or V-104) using flex hose. When one drum is filled with water, the flex hose is moved to fill another one with filtered water. While this is happening, salt water is being electrolyzed into bleach (E-101). The battery (M-101) is the power source for the electrolysis unit. When the battery does not have enough power to continue electrolysis (~ 6 V) it is charged using the bicycle connected to a DC motor (B-101). When a batch of bleach is finished, it is poured into one of the 100 gallon drums, allowed to sit for 30 minutes, and then allowed to enter one of the holding vessels for the clean water (V-105 or V-106). Once the holding vessel is full, it must be left to sit overnight so that the bleach has enough time to react with any potential microorganisms still present in the filtered water. After the clean water is left overnight, the free chlorine concentration should be tested using water test strips. As long as the chlorine concentration is between 1 and 5 ppm, the water may be pumped using hand pumps (P-102 or P-103) into individual buckets (CW-102 or CW-103) for the locals to use. If the chlorine residual is less than 1 ppm, then it is possible that not all of the microbial agents have been neutralized. Therefore more bleach must be added to the water, allowed to sit, and retested using a test strip. If the chlorine residual is greater than 10 ppm, then it exceeds the recommended safe allowance for drinking water. Therefore more filtered but unbleached water must be added, allowed to sit, and retested using a test strip. It is important to note that because the water is being taken from the same source, once a general method of the process is established on site, very few changes will have to be made to get consistently clean water.

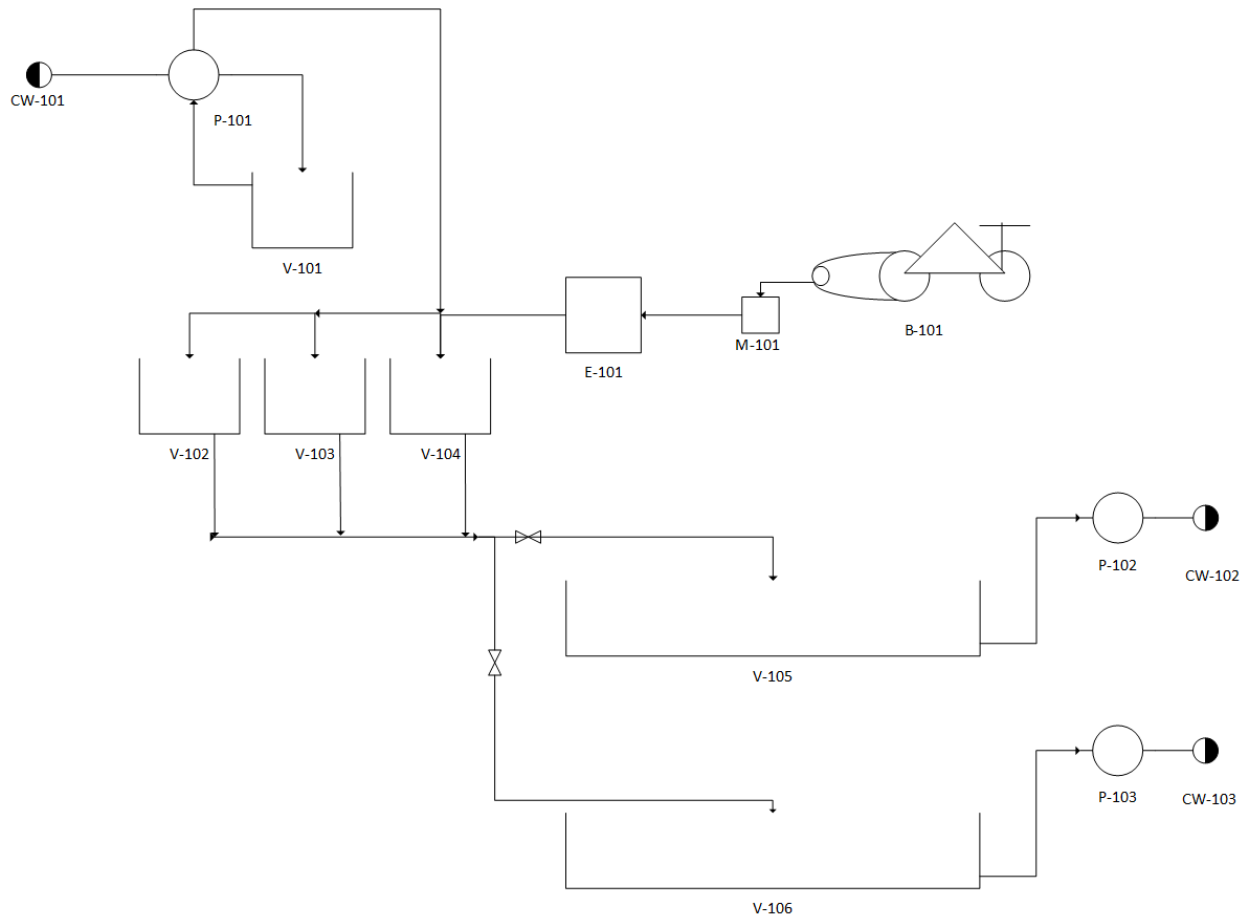

Figure 1: A process flow diagram of the water purification system.

Treadle Pump

The original design called for a two-person treadle pump. Experimentally, it was determined that one piston of the treadle pump can move around 5 gal/min (Figure 2A). Therefore it is theoretically possible to pump the 1,500 gallons required in 5 hours of continuous operation. Therefore a one person treadle pump is sufficient to meet the pumping requirements. In addition, it was determined that a bicycle would provide a more effective means of charging the battery (discussed in Electric Generator). Figure 2B shows the volume of water that flowed through the treadle pump for different strokes of the pump. A stroke is defined as one up and down movement of the pedal. In order to achieve the required 1,500 gallons per day, the operator of the treadle pump would need to complete about 15-20 strokes per minute.

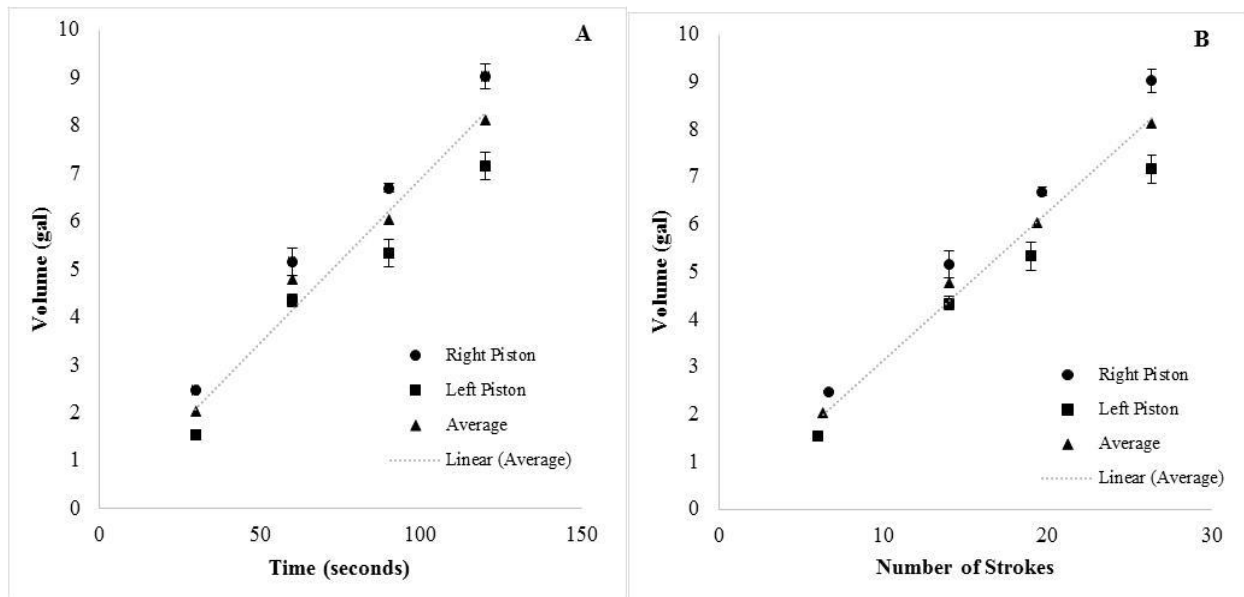

Figure 2: Performance of the treadle pump for A) volume flowrate of water and B) volume of water per stroke. Results represent an average of 3 different experiments.

Sand Filtration

The purpose of filtration is to remove suspended particles from water by passing the water through a medium, in this case, sand. There is a slight pressure drop through the filter. As the water passes through the filter, impurities get caught in the sand and the clean water passes through. The filtered water is collected and then disinfected before use (9). Filtration is an important step in the purification process because it reduces the turbidity (cloudiness) of the water. Turbidity is a measure of the decreased passage of light through water due to suspended materials (10). Although turbidity is not harmful on its own, turbid water is difficult to disinfect. Microorganisms growing on the suspended particles may be hard to kill using disinfection, and the particles themselves may chemically react with chlorine, making it difficult to maintain a residual chlorine level in the system. This illustrates the importance of filtration in this project design. In order to ensure the bleach is killing the microorganisms, the water must be filtered properly to remove suspended particles. For this system it was experimentally determined that the sand filter was able to decrease the turbidity on average by 87% ($\pm 10\%$) for water that ranged in initial turbidity from 15 to 70 NTU (Nephelometric Turbidity Units). The water was collected from a nearby lake, Lake Fayetteville.

Electric Generator

The WaterHOGs design needed a sustainable power source to run the electrolysis unit. In the original proposal, it was suggested that the treadle pump should be used as the power source for the electrolysis unit. However, upon further research, it was determined that using the treadle pump would not produce enough rpm to power the electrolysis unit. The original design also required a scotch yoke, a mechanism that converts linear motion into rotational motion or vice

versa, connected to a generator. The generator would then be used to provide direct current to the electrolysis unit. A problem with this proposed design was the stability of the scotch yoke. The rotating part of the scotch yoke mechanism, a flywheel, is attached in a way that makes it nearly impossible to stabilize without the utilization of more advanced tools. To replace the treadle pump and scotch yoke mechanism, a bicycle with a belt attached to a scooter DC motor was suggested. This new proposal was adopted and integrated into the design.

The system also needed to produce enough sodium hypochlorite in a day to purify the 1,500 gallons of water and therefore a consistent supply of current was required. The pedaling of the bike produces a varying current depending on the age, size, tiredness, and gender of the operator. Therefore, it was determined that a potential solution would be to use a 12 volt battery which can easily be obtained from a scrapped vehicle. This altered the function of the bicycle generator from directly powering the electrolysis unit to charging the battery. The battery is able to supply the electrolysis unit with steady current (3-5 amps) required to produce the desired concentration of sodium hypochlorite.

The issue with utilizing a battery is measuring its charge. A battery will hold a certain voltage (typically ~12 volts) until it has been completely discharged when the voltage drops dramatically. There is no indication that the battery was being discharged besides the lowering concentration of the sodium hypochlorite produced after every batch. In order to produce consistent batches of sodium hypochlorite, the battery must be above 12 volts when running electrolysis. Through experimentation, it was determined that the battery could be fully charged after pedaling the bike approximately nine hours, operating on the fourth gear of an 18 speed bike, producing an average of 3-4 amps of current. The charging was done in 30 minute intervals.

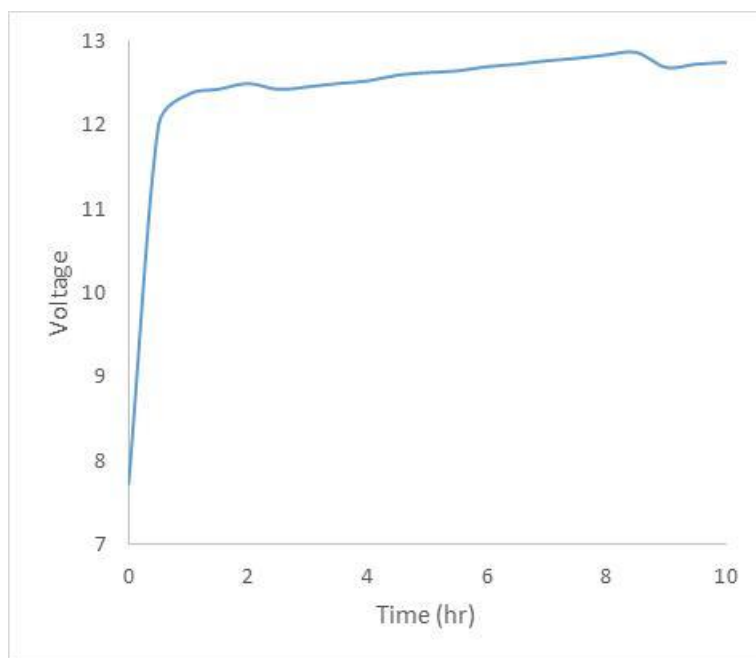

Figure 3: Charging of battery as a function on time pedaling the bicycle.

Figure 3 shows the experimental correlation between the actual battery voltage reading obtained using a voltmeter as compared to the amount of time pedaling the bicycle. As the data shows after about 1 hour the battery was able to be charged from ~ 7.7 volts to 12 volts. Therefore, an hour of pedaling should be sufficient to charge the battery after each electrolysis experiment.

Electrolysis

In Phase I of this project, Team WaterHOGs determined a sodium hypochlorite or bleach generator would be the best source of disinfection for the developing world. Sodium hypochlorite generators were first developed for spas and swimming pools (12) and are now in widespread use in this application. The generator eliminates the problem of the user having to handle sodium hypochlorite and instead allows clean water to be produced with only a slightly salty pool. According to EPA guidelines (13), bleach can be used for disinfecting drinking water by mixing 1/8 teaspoon of 6% by weight sodium hypochlorite solution, or common household bleach, per gallon of water and allowing the water to sit for 30 minutes. This level of chlorine is also within the level considered safe according to World Health Organization guidelines (14). Further, using an *in situ* generator requires less free chlorine because the slightly salty water also provides some resistance to freshwater bacterial growth (15).

Electrolysis experiments were designed and performed to chemically change a 3% salt (sodium chloride) water solution into sodium hypochlorite. Each electrolysis experiment was run for an average of about 40 minutes. Figure 4A illustrates the relationship between sodium hypochlorite production and time elapsed with a fully charged 12 volt car battery.

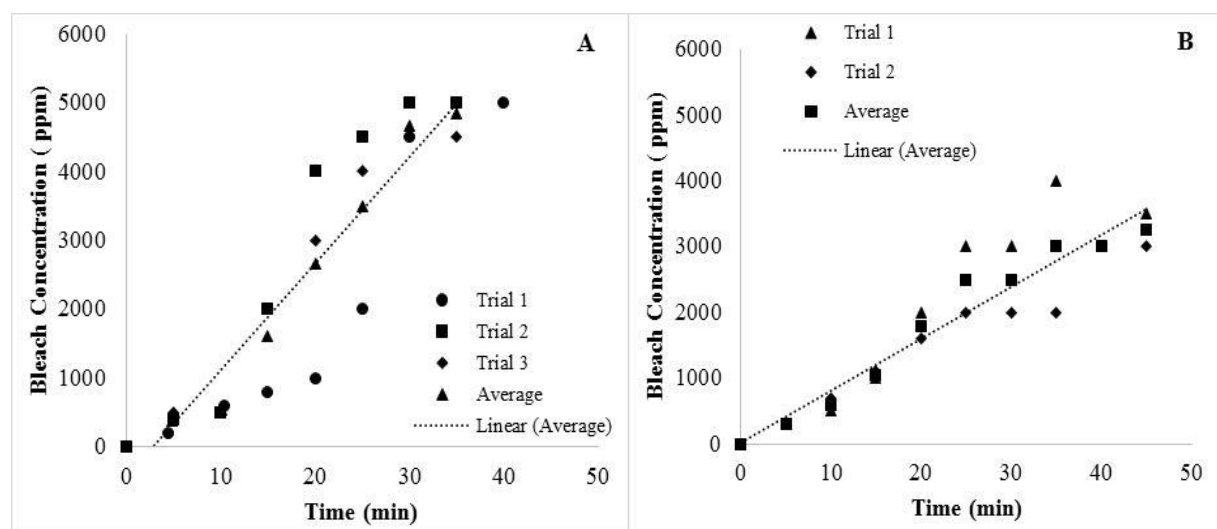

Figure 4: Concentration of bleach (sodium hypochlorite) produced over time by the 2 L electrolysis system using A) a fully charged or B) a discharged 12 volt car battery.

These experiments were used to create a guideline for the estimated minimum time the electrolysis unit needed to be run to obtain the target sodium hypochlorite solution. In order to satisfy the EPA requirement of 3.8 g of sodium hypochlorite per 100 gallons of water, it was determined that a 2000 ppm of sodium hypochlorite would need to be generated in a 2 L reactor, which also allows for sufficient free chlorine to be left in the water. As Figure 4A shows, the 2 L electrolysis unit is able to generate 2000 ppm of sodium hypochlorite after a 17 to 20 minute run time per batch. Figure 4B illustrates the relationship between sodium hypochlorite production and time elapsed when the battery charge was depleted (~ 5 volts). The discharged battery is able to generate 2000 ppm of sodium hypochlorite in the 2 L system after a 20 to 25 minute run time per batch. Therefore, there is only a 3-5 minute difference in the time required to produce the required amount of sodium hypochlorite. This indicates that even if the battery cannot be fully recharged between electrolysis runs that it will still have enough voltage for the electrolysis process.

The results of these experiments show that a sufficient amount of sodium hypochlorite could be generated to treat the required 1,500 gallons of water per day. Based on a 20 minute run time to treat 100 gallons of water, the electrolysis unit would need to be run ~ 5 hours per day to produce enough sodium hypochlorite to disinfect the 1,500 gallons.

Instructions for Construction

A set of instructions is being developed that can be interpreted with primarily pictorial representations so that people with limited literacy can still assemble the equipment. An example of these instructions in English and Hindi can be seen in Appendix A.

Cost Analysis

The original proposal specified that the design for the water purification system would cost the developing community less than \$500 to construct. Table 1 outlines the capital (construction) costs for the water purification system that was built by the P3 WaterHOGs team and the estimated cost for building the team in the developing nation of India. The cost for the unit build by the P3 WaterHOGs team was ~\$553, which included purchasing wood, a new car battery, and a new bicycle. For the estimated costs in India, a previous report of a treadle pump construction using bamboo for \$43 was used for the treadle pump cost estimate (16). The car battery, DC motor, and bicycle were all estimated to be obtained as negligible cost since they would be scrapped from non-function parts and assembled into the system. The overall system was estimated to cost ~\$226 for construction in India. In addition, to the construction costs the operating costs reflect supplies that would need to be purchased to keep the system operational after construction. Table 2 outlines the operating costs needed for the sodium hypochlorite generator which total ~\$103 per year.

Table 1: Capital Costs

Capital Cost				
Equipment	P3 Design Cost		India Cost Estimate	
	Pieces	Cost, USD	Pieces	Cost, USD
Treadle Pump	Wood	\$52.40	Bamboo and Supplies	\$43.00
	Nuts, Bolts and fittings	\$56.01		
	Pulley	\$3.48		
	Steel Cable	\$6.08		
	Metal Rod	\$5.63		
	3" Pistons	\$13.46		
	PVC pipe and Fittings	\$31.59		
Hypochlorite Generator	12 Volt Car Battery	\$94.99	12 Volt Battery	\$0.00
	DC Motor	\$0.00	DC Motor	\$0.00
	Cables and Belt	\$49.98	Cables and Belt	\$19.99
	2x4 Ply Wood	\$5.38	Bamboo and Supplies	\$0.00
	Bicycle	\$98.74	Bicycle	\$0.00
	Container	\$0.00	Clay Pot	\$0.00
	Voltmeter	\$60.00	Voltmeter	\$80.00
Filter	Sand	\$3.98	Sand	\$0.00
	Drainage Rock	\$3.48	Gravel	\$0.00
	Bucket	\$0.00	Bucket	\$15.00
	PVC pipe and fittings	\$25.12	PVC pipe and fittings	\$19.63
Hand Pump	PVC pipe and fittings	\$42.40	PVC pipe and fittings	\$42.40
Storage and Lines Piping		\$0.00	Storage Drums	\$0.00
		\$0.00	Tarp	\$39.98
		\$0.00	3/4" Hoses	\$25.00
TOTAL		\$552.72		\$260.00

Table 2: Operating Costs

Operating Costs				
Equipment	P3 Design Cost		India Cost Estimate	
	Supplies	Cost, USD	Pieces	Cost, USD
Hypochlorite Generator	Sodium Chloride	\$0.44	Sodium Chloride	\$17.21
	Electrodes	\$100.00	Electrodes	\$20.00
	Testing Strips	\$45.00	Testing strips	\$65.48
	TOTAL (for project period)	\$145.44	TOTAL (per year)	\$102.69

4. Discussion, Conclusions, Recommendations

A life cycle assessment evaluates the human and environmental impacts of the water treatment system. In India, many people die every year because of limited access to potable water (7). Team WaterHOGs' system will positively impact communities in India by providing them with an inexpensive, easy way of producing clean water. The system, which was specifically designed for India, can be adapted to any developing nation and would help reduce drinking water mortality rates.

Since this system is made out of materials indigenous to India, there will be minimal environmental impact. One part of the system needing careful examination is the generation of sodium hypochlorite. Using sodium hypochlorite as a disinfectant has both advantages and disadvantages. While chlorine gas can escape to the surrounding atmosphere (17) and at high concentration chloride has serious health effects (18), the concentrations produced in the proposed design are too low to have significant effects. Another consideration is the environmental impact if there were a chlorine spill. The amount of chlorine produced per batch of treated water is 0.002 L and is not large enough to have a significant impact (19) and the European Union has found that there are no significant risks to using chlorine as a disinfectant for water (20). It is therefore clear that the positive human impact outweighs the negative environmental impact.

The water purification system designed in phase 1 provides an inexpensive, highly accessible water purification system capable of supplying local communities with enough water for daily activities with minimal capital investment or maintenance required. The availability of clean water will greatly benefit the people of these communities by increasing their quality of life. In a lot of isolated areas where necessary resources like clean water and electricity are scarce, social, economic, and human development are hindered tremendously. Therefore the implementation of these water purification systems will bring about many opportunities for rural communities. The WaterHOGs' design not only produces clean water but it also utilizes technologies that can be applied to other needs. The treadle pump can replace highly complex pumps, the filtering system can be implemented practically anywhere because of its simple design, and the bike generator/charger can be used as a power source for many other devices.

Phase I proved the feasibility of designing and building a working water purification system with minimal cost and limited materials. These types of systems, while simplistic, prove to be much more valuable for developing communities. In addition, the development of a set of instructions for constructing these systems anywhere in the world creates the potential for significant global impact.

Based on Phase I research, Team WaterHOGs feels confident about the success of this type of system should it be implemented during Phase II. Experimentation carried out by the team on the individual system components proved the ability to effectively pump water, decrease particulate matter, produce a level of sodium hypochlorite for microbial disinfections, and create a set of instructions for local construction. Further testing regarding the performance of the equipment after extended, continuous usage might be necessary. This could indicate areas of

future refinement for the instructions and aid in the long term use of the systems. Therefore, field research centering on the implementation and operation of multiple units in third world villages is highly recommended. Phase II proposes to do this by working with Christ University in India and implementing the system in key villages in their area.

5. Assurance that Research Misconduct Has Not Occurred During the Reporting Period

The University of Arkansas, through the Provost and Vice Chancellor for Academic Affairs, Academic Initiatives and Integrity strives to create a culture of honesty and personal and professional responsibility among its students, faculty and staff. As a community of scholars, we uphold academic integrity as foundational to appropriate conduct within the university setting. Academic Initiatives and Integrity manages outreach efforts for policy education and facilitates the University's process for alleged violations with the All University Academic Integrity Board. The Academic Integrity Policy was strictly followed throughout this project.

6. Publications / Presentations of Phase I Work

None to date.

Proposal for Phase II

1. P3 Phase II Project Description

Project Description, Novelty and Evaluation

The primary goal of Phase II is to implement the system in a local community in India. This community will be identified through interactions with Christ University in India with whom the University of Arkansas already has a relationship (see letter from Bryan Hill). As part of their Center for Social Action they are already working with slums to improve the quality of life and the water purification system fits well with their work to improve impoverished areas of India. Through construction of this system in India, the team will be able to assess modification to the instructions, the type and accessibility of local materials, attitudes toward the implementation of the system and the system's performance during extended real time operation.

The proposal for Phase II focuses on the implementation of this project as a way to apply simple, yet effective technologies to provide attainable water purification options for small, rural communities in third world countries. This project contains two very important novel components. Previously demonstrated technologies have been combined into a unique system that can handle water from untreated non-potable sources, and a set of instructions has been developed that could be used anywhere in the world with locally sourced materials and with minimal educational or technical background required.

Overall Sustainability of Proposed Project

Given the low capital and start-up cost related to this project, as well as the amount of potable water treated daily, the proposed system is inherently sustainable. Reliability testing and cost analysis performed on the system components show the ability to run for extended amounts of time with very little maintenance required. Furthermore, the pictorial instructions and system logistics can be easily adjusted to fit the needs of individual communities. This includes the use of different materials indigenous to the region.

Educational and Teamwork Aspects of the Proposal

Phase I was very successful as an educational tool because it acted as the culmination of four years of technical training for the members of Team WaterHOGs. The project required the implementation of a variety of skills that make up the training of professional engineers. This project branched out to many areas, including civil engineering, electrical engineering, communications, and marketing. Furthermore, the students learned to apply and synthesize their technical knowledge of chemical engineering in areas such as reaction kinetics, mass transport, fluid mechanics, materials science, and engineering design. They were responsible for all of the major decision making, research, experimentation, documentation, construction, and testing of the system. As a result of this project, Team WaterHOGs gained valuable experience in all of these areas. The entire experience served to strengthen each individual team member's engineering skills, which will be invaluable to them as they prepare to enter the workforce.

Finally, the group environment fostered the development of interpersonal communication skills and teamwork. They were responsible for distinct tasks that built upon each other, all within a hierarchical structure. They were required to submit progress reports, literature reviews of sources, and troubleshoot problems all while maintaining common professional practices that will become standards in their work lives.

Phase II of this project will continue to enrich the educational experience of students involved in the project. For this phase, the students involved will be responsible for the development of a clear plan for the implementation of the system in rural communities in India. They will need to work together closely before and after the trip with Christ University in India to target specific locations, organize any preparatory work, and work on marketing and techniques to make the system as enticing to the communities as possible. This experience will represent an invaluable experience for the students involved; they will hone their engineering skills while also learning about a foreign culture. In addition, to learning from the construction the students will also take input from the locals and use it to modify or even redesign the system or instructions as necessary. By returning to the system a year later the students will be able to learn about replacement of wearable materials and unanticipated challenges.

The finished system, or individual components of it, can also be implemented as display units for science fairs, classroom visits, and as part of the science and engineering outreach programs within the University of Arkansas. The treadle pump, electrolysis unit, and bike generator principally can be used to explain complex concepts like batteries, chemical reactions, and momentum balances to a variety of K-12 students.

2. Quality Assurance Statement

Due to the nature of this project, the bulk of the research and development was performed during Phase I. The students responsible for the design and execution of the experiments have had extensive laboratory experience through both coursework and research. All experiments were performed in triplicate and summarized results were prepared using standard data analysis techniques. Raw data and experimental observations were diligently kept and recorded by the student researchers.

In Phase 2, student will be responsible for making sure that the systems constructed in India are safe and that the operators know how to evaluate the sodium hypochlorite levels to ensure microbial disinfection while also maintaining a safe level for drinking. Students will also journal their experiences during the on-site construction and any modifications or necessary changes that they observed being made to the system. This will allow them upon their return to develop new solutions to problems that may arise or to make appropriate modifications to the instructions. A similar process will be used on the second visit to ensure that the existing model is still being operated in a safe manner and that the new system is constructed appropriately.

3. Project Schedule

Task 1: Review Phase I Work

The Phase II students will review the work completed by the Phase I team and make any changes to the design they deem necessary.

Task 2: Pre-trip planning

Students will work with a Christ University in India to identify target communities and establish and accomplish key goals prior to the trip.

Task 3: Travel to India

Students and advisors will travel to India to implement the system.

Task 4: Construction of Water Purification Unit

Students will work with local communities to build the water treatment system

Task 5: Extended Reliability Assessment

Students will work for a full week to test the installed systems on a continuous daily basis.

Task 6: Economic Analysis

The team will continue to evaluate the economic viability utilizing the information from the installed systems.

Task 7: Report Results

The experimental results, as well as series of field ready systems installed in targeted communities in India, will be documented. If applicable, the students will work towards publication of their results.

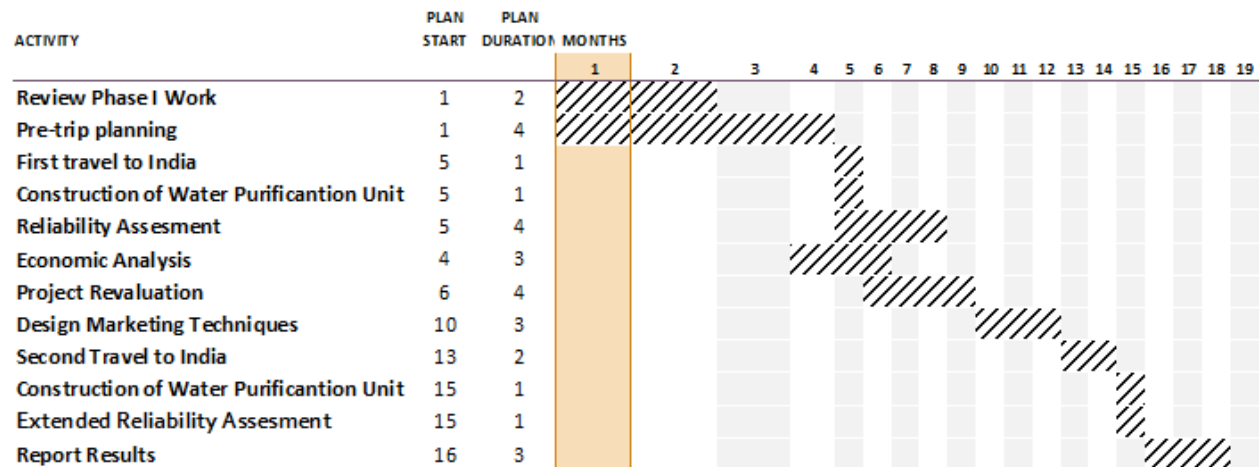

Figure 5: Gantt table describing the proposed schedule for Phase II.

4. Partnerships

Phase I was successful in laying the groundwork for partnerships with key players. The

most important partnership established was with the director of the Global India study abroad program, Mr. Bryan Hill. He will act as the liaison between the team and a private university, Christ University, in India; he will also provide an important perspective on his experience with running the India study abroad program for the College of Engineering for eight years. His letter of support can be seen in Section VI. Other individuals at the University have also been helpful with the research process. Dr. Julian Fairey from the Civil Engineering department assisted with performing water turbidity testing and designing the filtration system. Faculty and technical staff in the Chemical Engineering department have assisted the Phase I team in the design and construction of the electrolysis unit and the power generator.

The Phase II team will also work closely with the Ralph E. Martin Department of Chemical Engineering at the University of Arkansas to continue improving the design and schematics of this process. The department head, Dr. Babcock, has written a letter of support for Phase II. The department has also given their full support to use Phase II as credit for the honors section of the senior capstone design course (CHEG 4443), as well as allowing the project to be used as an honors thesis. The department is fully committed to utilizing this project as an educational tool for its chemical engineering students, as well as the science and engineering outreach programs.

C. References

1. Annan, K. United Nations Press Release from www.un.org/News/Press/docs/2003/sgsm8707.doc.htm 2003.
2. World Health Organization. Facts and Figures: Water, Sanitation, and Hygiene Links to Health. www.who.int/water_sanitation_health/publications/factsfigures04/en/
3. SPIE. High-Tech Engineering Export Low-Tech Solutions to Developing Countries. Spie.org/x23125.xml 2008.
4. Reed, Brian.; Reed, Bob. Technical notes on Drinking-Water, Sanitation and Hygiene in Emergencies. World Health Organization. Retrieved March 3, 2014, from www.who.int/water_sanitation_health/publications/2011
5. World Health Organization. Chlorine in Drinking Water. Guidelines for Drinking Water Quality 1996, Ed. 2.
6. VOCless Pulping, Waste Water (2010-13). "Aerobic Waste Water Treatment Process." Retrieved February 28, 2014 from <http://voclesspulping.com>.
7. Tighe, M.R.; McCutchen, H.L. Swimming Pool Chlorinator System. 1978, 811, 989.
8. Sustainable Infrastructure: Energy Efficiency for Water and Wastewater Utilities" (11, 2013). Retrieved Feb 28, 2014 from water.epa.gov.
9. Smart growth in Small Towns and Rural Communities (10, 2013). Retrieved Feb 28, 2014 from epa.gov/smartgrowth.
10. Shaffer, D. L., et al" Seawater desalination for agriculture by integrated forward and reverse osmosis: improved product water quality for potentially less energy" *Journal of Membrane Science*, Volumes 415–416, 1 October 2012, Pages 1-8.

11. R. Franklin. (07, 2011) "How does UV Disinfection Works." Retrieved February 28, 2014 from uvo3.co.uk
12. Morens, D.M.; Folkers, G.K.; Fauci, A.S. The Challenge of Emerging and Re-Emerging Infectious Diseases. *Nature* 2004, 430, 242-249.
13. Lesson 6: Filtration. Lesson 6: Filtration. Retrieved March 3, 2014, from <http://water.me.vccs.edu/courses/env110/lesson6.htm>
14. Yuasa Batteries Incorporated, NP Series. Retrieved March 19, 2014 http://www.yuasabatteries.com/pdfs/NP_1.2_12_DataSheet.pdf
15. Environmental Protection Agency. Emergency Disinfection of Drinking Water. water.epa.gov/drink/emereprep/emergencydisinfection.cfm 2010.
16. Engardio, P.; Capell, K.; Carey, J.; Hall, K. Responsible Practices Actually Help a Company's Bottom Line. *BusinessWeek* 2007, 4019, 50.
17. Al-Haq, M.I.; Seo, Y.; Oshita, S.; Kawagoe, Y. Disinfection Effects of Electrolyzed Oxidizing Water on Suppressing Fruit Rot of Pear Caused by *Botryosphaeria Berengeriana*. *Food Research International* 2002, 35, 657-664.
18. Turbidity. Home. Retrieved March 1, 2014, from <http://water.epa.gov/type/rsl/monitoring/vms55.cfm>
19. Practical Action Nepal, Treadle Pumps. Worldwide Helpers. 2010. Retrieved March 10, 2014 from http://www.worldwidehelpers.org/wwhweb/uploads/files/KnO-100434_Treadle%20Pumps.pdf
20. Office of Pollution Prevention and Toxins, Chemical in the Environment: Chlorine. U.S. Environmental Protection Agency. August 1994. Retrieved March 17, 2014 from http://www.epa.gov/chemfact/f_chlori.txt
21. New York State Department of Health. The Facts About Chlorine. August 5, 2004. Retrieved March 17, 2014 from http://www.health.ny.gov/environmental/emergency/chemical_terrorism/chlorine_tech.htm
22. The Emergency Response Safety and Health Database, Chlorine: Lung Damaging Agent. Centers for Disease Control and Prevention. 2003. Retrieved March 18, 2014 from http://www.cdc.gov/niosh/ershdb/EmergencyResponseCard_29750024.html
23. World Chlorine Council, Drinking Water Chlorination. 2008. Retrieved March 18, 2014, from http://www.worldchlorine.org/publications/pdf/WCC_Policy_Paper_Water_Chlorination.pdf

Appendix A: Example of Pictorial Instructions

■ “People, Prosperity and the Planet” ■



WaterHOGS

INSTRUCTIONS: TREADLE PUMP

STEP 1- FOUNDATION: **Cut** a 2x4 stud in half

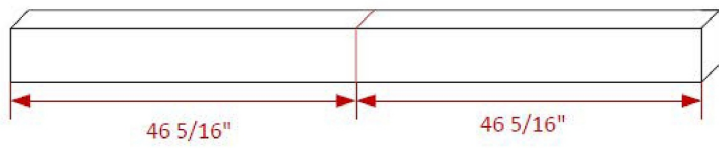

STEP 2- FOUNDATION: Place foundation together and **nailed** together

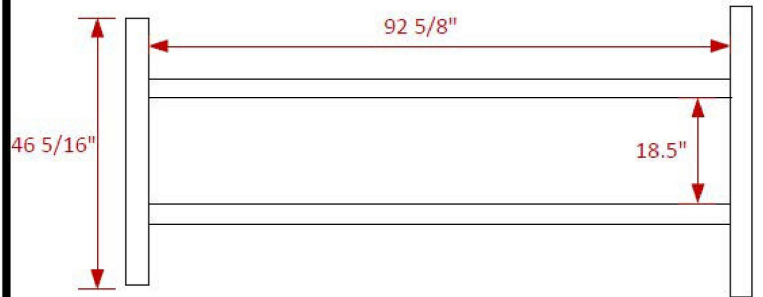

STEP 3- PIVOT: **Cut** boards for pivot as shown below:

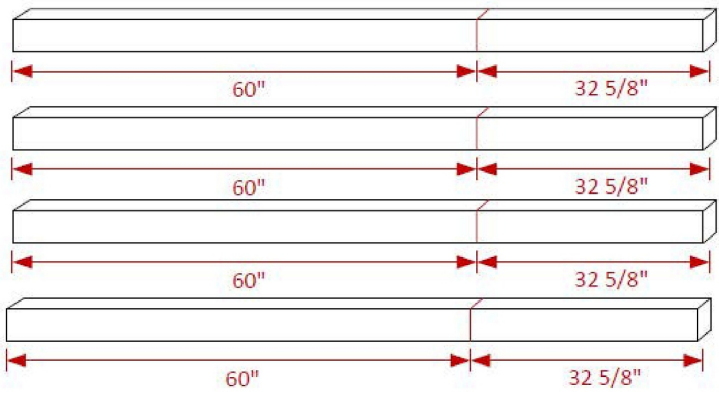

STEP 4- PIVOT: **Drill** $\frac{5}{8}$ " hole in pivot as shown below:

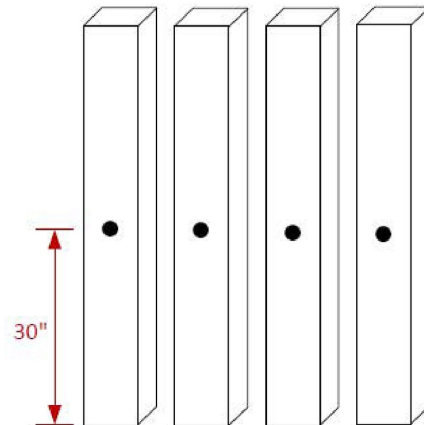

STEP 5- PIVOT: **Cut** Cross Braces for the Pivots

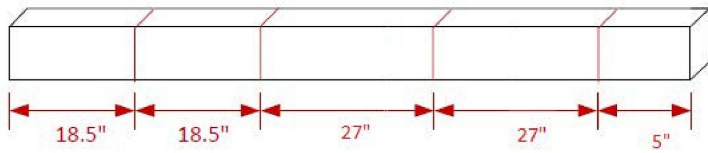

STEP 6: PIVOT – **Align** the pieces for the PIVOT section as shown below and **nail** together

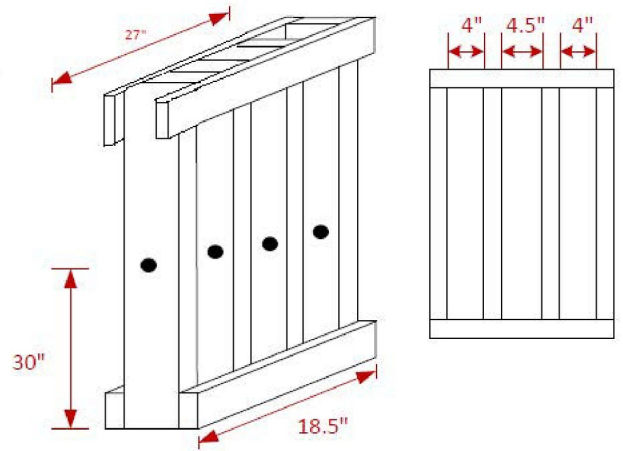

STEP 7 : PIVOT - **Align** Pivot on Foundation and **Nail** to Foundation

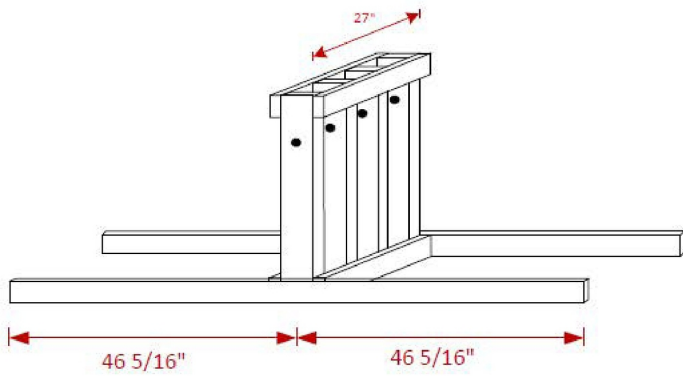

STEP 8 : MOUNTING BRACKETS - **Cut** stud for piston-mounting bracket

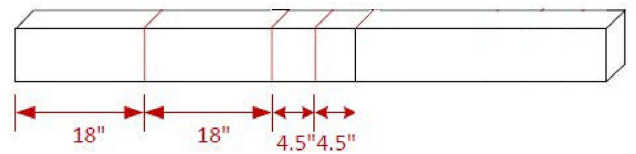

STEP 9 : MOUNTING BRACKETS – **Align** mounting brackets as shown below and **nail** together. Nail 4.5" boards above the 18" with 1.5" overlapping the placement of the pistons

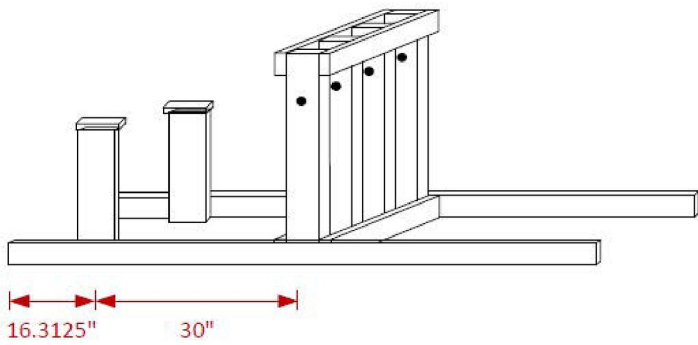

STEP 10: BEAMS – **Cut** 5/8" square at center of 2x4 stud for both beams.

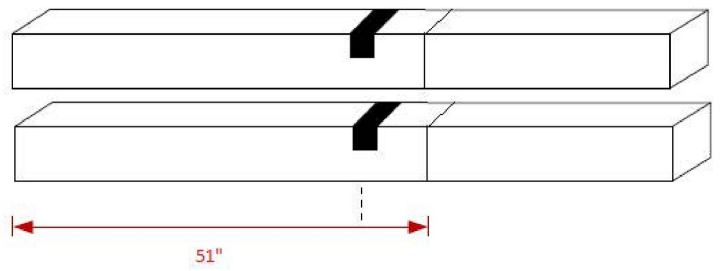

STEP 11: BEAMS – **Cut** two 2x4 studs as support for the beams.

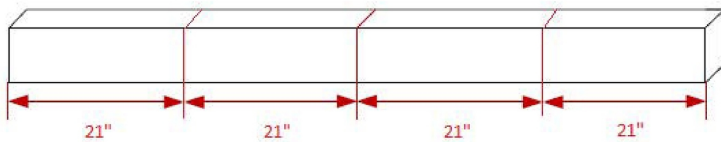

STEP 12: PIVOT – **Insert** the rod through the 5/8" hole in the pivot.

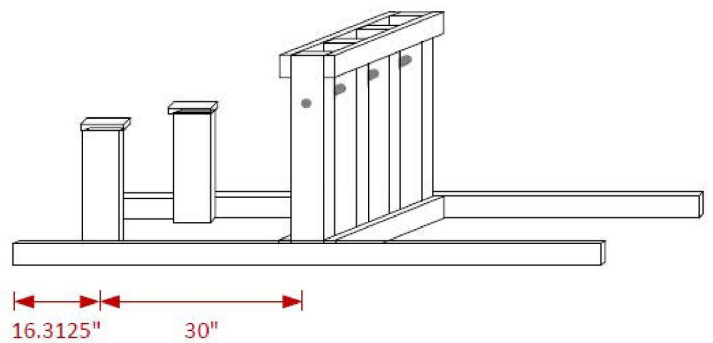

STEP 13 : BEAMS – **Align** beam as shown about rod and **nail** together.

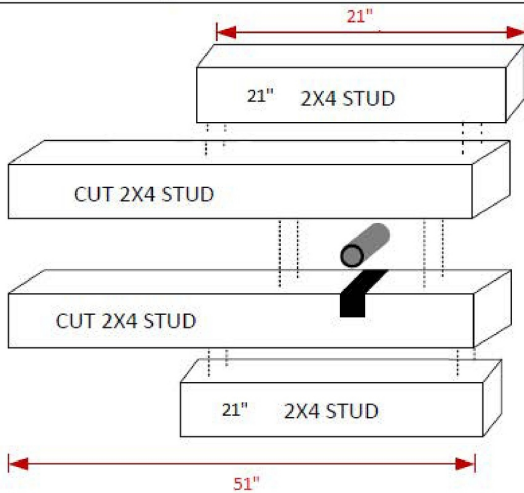

STEP 14 : BEAMS – **Mark** holes and **drill** for 1" dowel rod. This is a hole cut from the side. Also drill a hole from the top for part of the rod the go through.

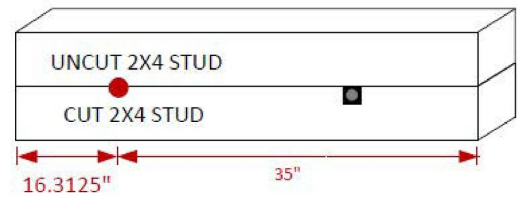

STEP 15 : PISTONS – **Cut** 4 18" pieces of the 4" PVC pipe, then **seal** one end with plastic cap covered in epoxy. **Drill** two 3/4" holes 3" from the bottom of the cylinder. These holes will need to be tapped for a threaded fitting. Place the holes on opposite sides of the cylinder.

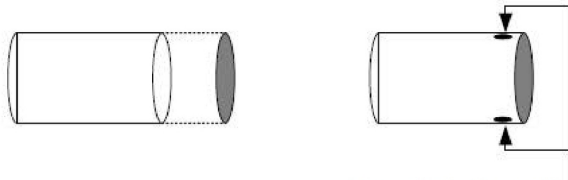
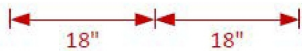
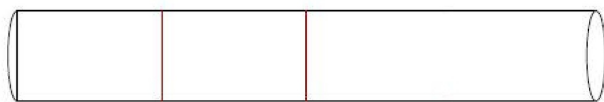

Drill and tap the 3/4" holes

STEP 16 : PISTONS – **Cut** flat PVC circles to fit inside of 4" PVC pipe.

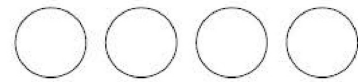

4 Circles made to account for thickness of leather in Step 17. Drill a 3/8" hole in the center of each circle.

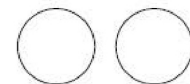

2 Circles made small enough to fit in the piston. Drill a 3/8" hole in the center of each circle.

STEP 17 : PISTONS – **Cut** leather seals for pistons, then soak in water for 20 minutes.

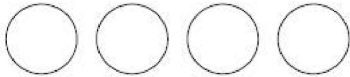

4 Circles made from leather.
Each circle has a diameter of 4.5"
Drill a 3/8" hole in the center of each seal.

STEP 18 : PISTONS – **Cut** all-thread into 24" sections, as well as the square supports into 18" sections.

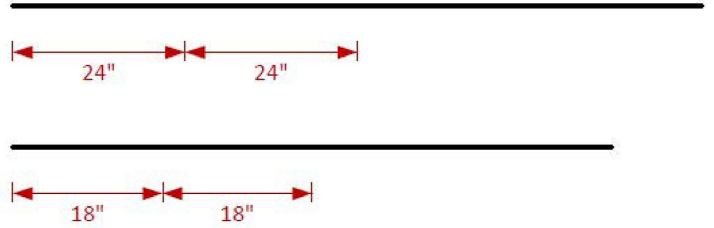

STEP 19 : PISTONS – **Assemble** the pistons as shown below.

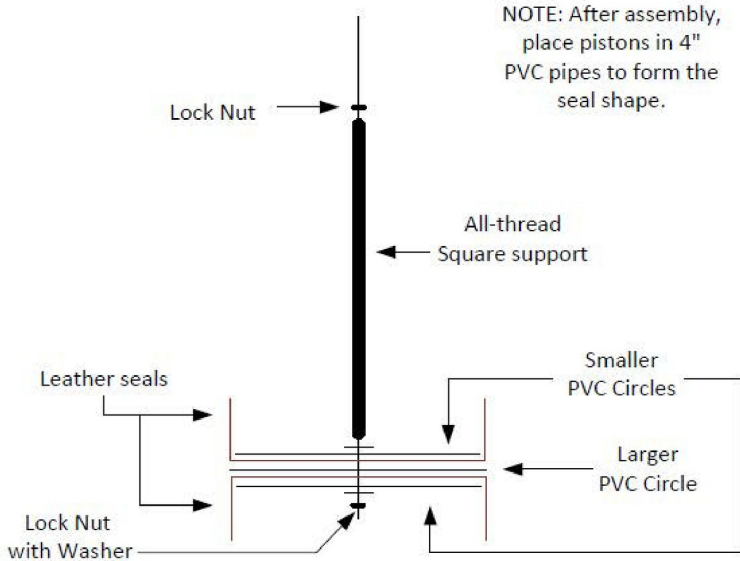

STEP 20 : PISTONS – **Mount** the pistons on the brackets.

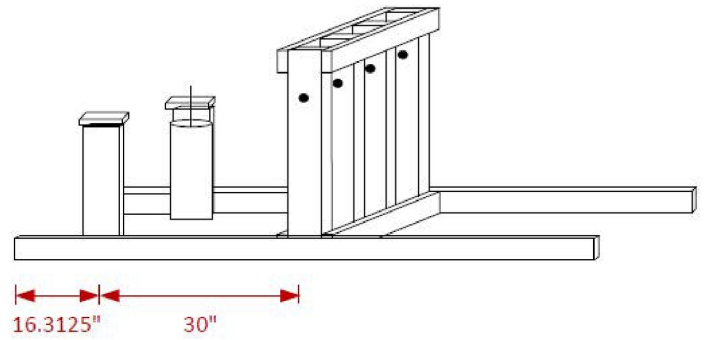

STEP 21 :BEAMS - Cut two 4" sections of 1" wooden dowel & drill 3/8" hole through center of each 4" piece.

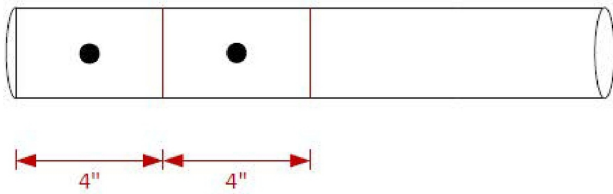

Step 22: Beams- Drill vertical 1" hole through the beam, then insert dowels into the beams horizontally. Also drill 3/8 holes vertically to insert the ropes.

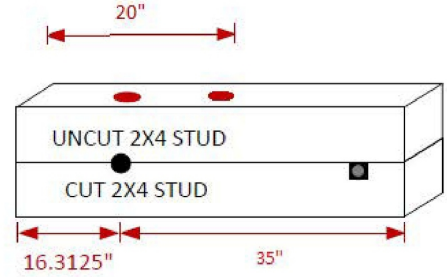

STEP 23: BEAMS – Insert rod through vertical hole and assemble together as shown below.

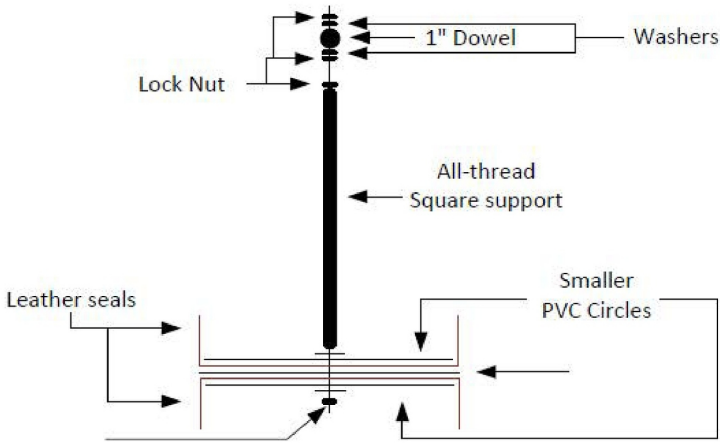

STEP 24: CHECK VALVE ASSEMBLY – Assemble the check valves and as shown below. (Four of each assembly). Apply solvent and glue liberally.

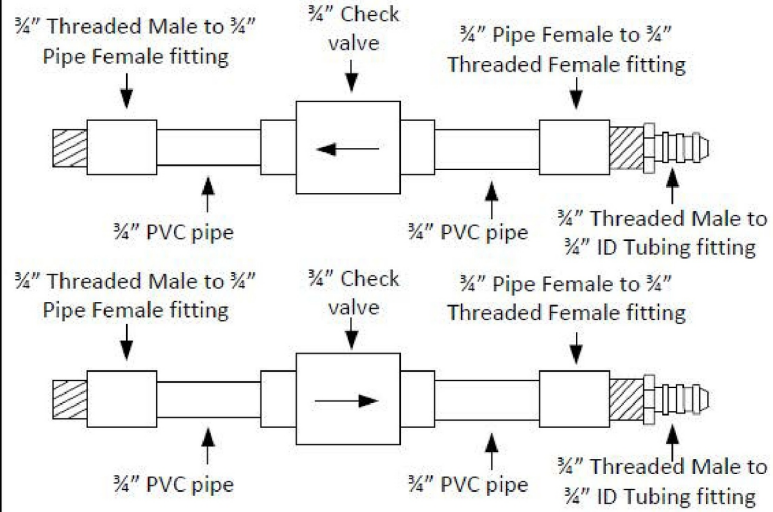

STEP 25 : BRACING – **Cut** the following triangles for bracing.

Cut six triangles from $\frac{3}{4}$ " plywood for bracing the pivot and safety rails.



Cut four triangles from $\frac{3}{4}$ " plywood for bracing the piston mounting brackets.

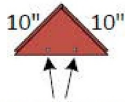

Note: $\frac{1}{2}$ " holes drilled at base for pipe fasteners

STEP 26 : SAFETY RAILS – **Cut** boards for safety rails as shown below.

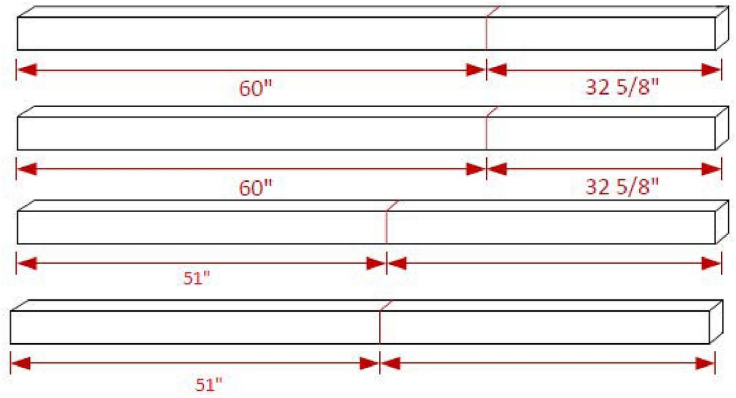

STEP 27 : SAFETY RAILS – **Align** safety rails and **nailed** to the foundation.

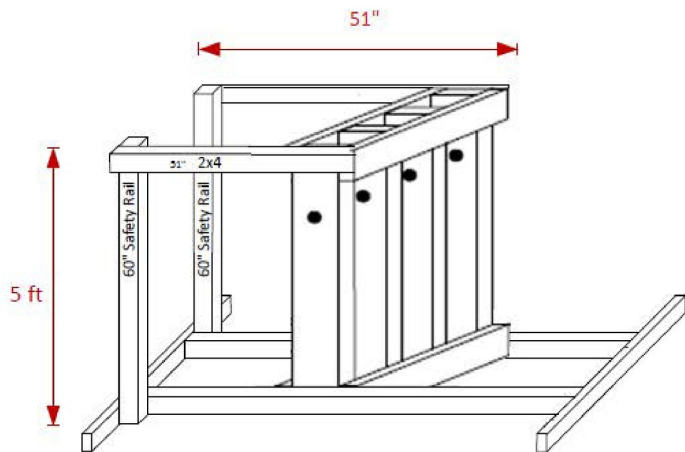

STEP 28 : BRACING – **Align** the bracing as shown and **nailed**.

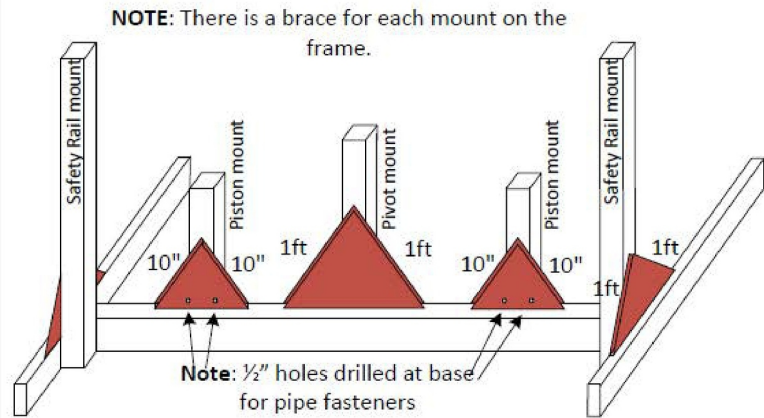

STEP 29 : CHECK VALVE ASSEMBLY – **Attach** assemblies to pistons. Place one of each assembly on every piston.

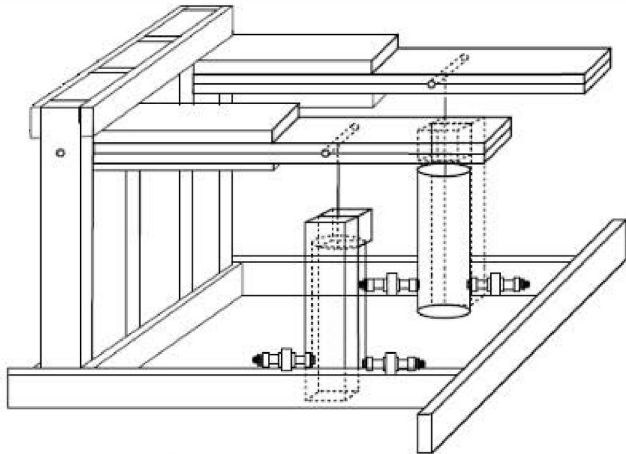

NOTE:
DON'T
put two
of the
same
assembly
on one
piston

STEP 30 – SAFETY RAILS – **Lower** the walking beams on one end until it rests on the wooden block. Underneath this, **attach** a crossbeam between the safety rails as shown. Repeat on opposite end.

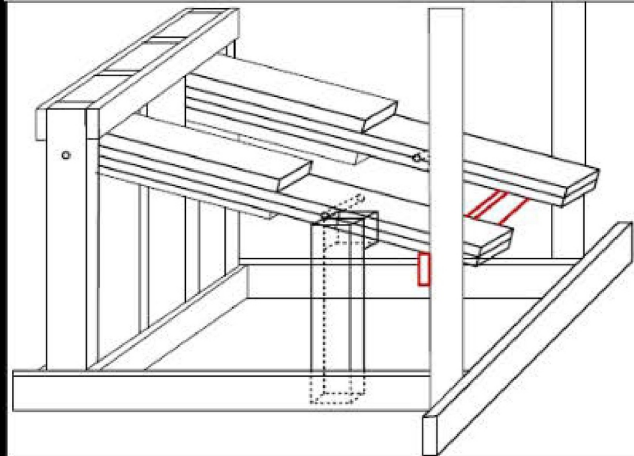

Step 31: Cut the 3/4" rod into 8" piece. Also cut out a 4" diameter circle out of ply wood for the pulley system.

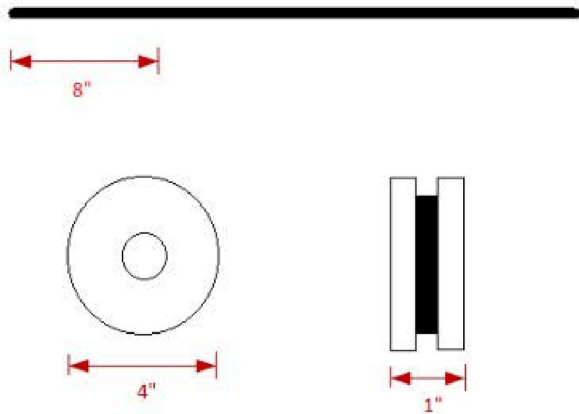

Step 32: Cut out two 27" 2X4. Drill 3/4 hole in the middle of the ply wood.

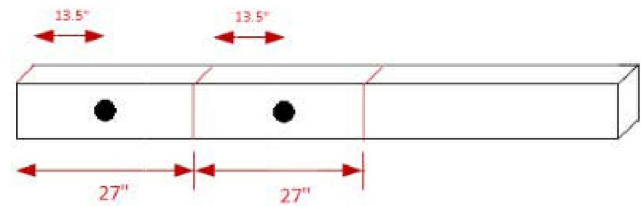

Step 33: Attach two 27" 2X4 15" and 19.5" respectively from the end.

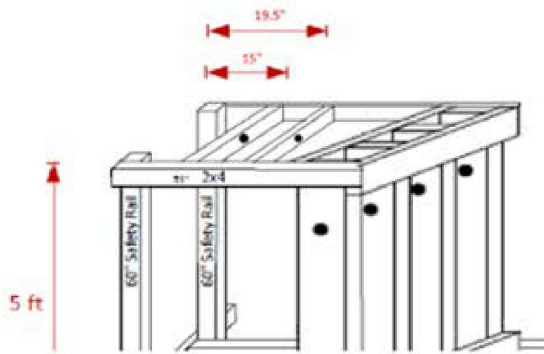

Step 34: Attach the pulley to the pump using the 3/4 rod.

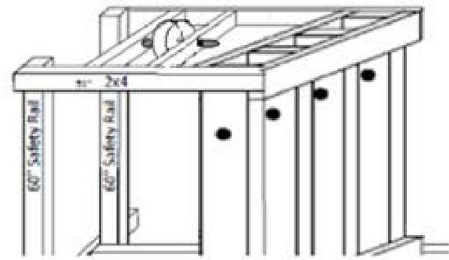

Step 35: Attach the string to the treadle around the pulley.

