

University of Arkansas, Fayetteville
ScholarWorks@UARK

Chemical Engineering Undergraduate Honors
Theses

Chemical Engineering

5-2013

Hydrocarbon Removal

Elizabeth Ashley

University of Arkansas, Fayetteville

Follow this and additional works at: <http://scholarworks.uark.edu/cheguht>

Recommended Citation

Ashley, Elizabeth, "Hydrocarbon Removal" (2013). *Chemical Engineering Undergraduate Honors Theses*. 9.
<http://scholarworks.uark.edu/cheguht/9>

This Thesis is brought to you for free and open access by the Chemical Engineering at ScholarWorks@UARK. It has been accepted for inclusion in Chemical Engineering Undergraduate Honors Theses by an authorized administrator of ScholarWorks@UARK. For more information, please contact scholar@uark.edu.

An Undergraduate Honors College Thesis

in the

College of Engineering
University of Arkansas
Fayetteville, AR

by

This thesis is approved.

Thesis Advisor:

A handwritten signature in black ink, appearing to read 'W. K. Fung', is written over a horizontal line. The signature is fluid and cursive.

Thesis Committee:

A group of Chemical Engineering Undergraduates participated in the 2013 Waste-Management Education and Research Consortium (WERC) Competition. We competed in Task 4, titled "Hydrocarbon Removal." The task required a system that removed the hydrocarbons, both polar and non-polar, that can be found in flowback water from hydraulic fracturing at a rate of 1000 gal/min in order to protect a reverse osmosis (RO) membrane.

Our system used ultrafiltration (UF) to remove non-soluble hydrocarbons down to 0.005 micrometers and granular activated carbon (GAC) beds to remove the soluble hydrocarbons. This system gave total protection to the RO membranes. As my literature research and later lab research showed, any hydrocarbons in the feed solution for RO membrane would quickly and permanently foul the RO.

This system would be modular and mobile. I generated the process flow schematics for the full scale and bench scale processes. For the full scale, there would be a total of four GAC beds on one lowboy trailer. Another trailer would have the regeneration equipment. The third trailer would have the UF and RO membranes. I read an article by the Environmental Protection Agency that showed GAC can be regenerated. This was supported in an experiment that I conducted. This would increase the efficiency of the full scale process.

My other contributions to the WERC effort were towards the written report, in the Appendix, and the oral presentation. For the paper, I learned about competing technologies, both their strengths and their weaknesses. Using this information, I wrote the Executive Summary of the report. For the oral presentation, I presented the safety considerations for the full scale system. I learned about the Safe Drinking Water Act and the Clean Water Act; how they applied to our process and what laws would need to be followed.

I learned many elements of the design process that will remain with me for years to come. Our system was the application of off the shelf devices to achieve the goal of removing hydrocarbons. The system was simple yet effective.

Appendix



Hydrocarbon Removal

WERC 2013

Task #4

FracHOGS

**Ralph E. Martin
Department of Chemical Engineering
University of Arkansas
Fayetteville, AR**

Hydrocarbon Removal

Task #4

FracHOGS

Elizabeth G. Ashley

Hayden A. Dwyer

Colton J. Knox

Janvier M. Kwizera

Elisabeth E. Yates

Advisors:

Dr. Jamie A. Hestekin

Dr. W. Roy Penney

Ralph E. Martin
Department of Chemical Engineering
University of Arkansas
Fayetteville, AR

TABLE OF CONTENTS

EXECUTIVE SUMMARY.....	3
INTRODUCTION.....	4
TASK PARAMETERS.....	5
TECHNOLOGIES CONSIDERED.....	6
BENCH-SCALE APPARATUS.....	8
BENCH-SCALE OPERATION.....	12
LABORATORY EXPERIMENTAL RESULTS.....	13
FULL-SCALE DESIGN.....	16
ECONOMIC ANALYSIS.....	21
REGULATIONS.....	22
CONCLUSIONS AND RECOMMENDATIONS.....	23
REFERENCES.....	24

EXECUTIVE SUMMARY

The use of up to 7,000,000 gallons of fracking fluid per drilled well is a growing concern for those living in communities where fracking occurs¹. Thus, it is important to find a way in which the return water, about 25% to 30% of the original amount pumped into the ground, can be reused or can be treated so that it can be disposed directly to waterways. The current practice is deep well injection of excess flowback water, except for some locations where the flowback water is used for the next stimulation.

It is known that Southwestern Energy Company (SWN) reuses almost all their flowback water in this way for the wells they have completed in the Fayetteville Shale. The flowback water is stored in ponds on site until SWN finishes using the water at the drill pad. The flowback water is then trucked or piped to a central storage pond system. At SWN, a portion of fracking water is taken from central storage ponds and trucked to a new drill site to be reused. SWN's reasoning for reusing the water is that it costs money to pump the water into the ground and it costs money to obtain fracking water. Thus, they lose double the amount of money when they deep well inject the water. Reusing the flowback water for fracking also reduces demand for surface and subsurface water. Also to be considered, the methane from the Fayetteville shale is relatively dry (i.e., no heavy hydrocarbon fraction); thus, there are few liquid hydrocarbons that come from the well to contaminate the flowback water. The return water is contaminated with salts, where dilution by fresh water makes the solution suitable for the next fracking operation. This cannot be said about other shale plays, where returned hydrocarbon liquids are common. Hydrocarbons in the flowback water are a reason, in other locations such as the Bakken formation, significant portions of the flowback water are deep well injected². There has been some testing of systems that would clean the flowback water and discharge to the environment. One example is the Ecologix system that uses foam fractionation to clean the flowback water.

The hydrocarbons produced by the well can be light soluble hydrocarbons or polar micelle forming hydrocarbons or a combination of micelles and soluble hydrocarbons. Thus, a versatile system is needed. This involves two different processes: a process to remove the micelle formations and a process to remove the soluble hydrocarbons. The exception to this is multiple-effect evaporation. A solution that has gone through both treatments will be hydrocarbon free and can be diluted and injected into another well or sent through a reverse osmosis (RO) membrane, the permeate of which can be directly discharged to waterways.

When considering alternatives for micelle removal, there are a limited number of options for the first process. The use of pH adjusters will work, depending on the micelles. The use of harsh chemicals is not ideal and does not always work, as found in this investigation of the surrogate feed solution. Dilution will always work to dissolve the micelles by reaching the critical micelle concentration and the solution can then be treated as a soluble hydrocarbon solution; however, this can require up to thousands of times the original volume of water to be added. This is undesirable when water is to be conserved. Another option is to add a surfactant and use foam fraction to remove the micelles. This process will produce foam that has to be disposed of by deep well injection which is undesirable. Finally, ultrafiltration (UF) can be used. UF is compact and does not require any chemicals; thus, UF was the selected option for removing the micelles from the surrogate solution.

For the second step in the process, the soluble hydrocarbons must be removed. This can be done with a sand bed or a granular activated carbon (GAC) bed. The sand bed was eliminated due to disposal of the sand after it had been used. Thus, the second step in the FracHOGS process removes the soluble hydrocarbons by using two GAC beds. These beds are approximately 7.5' diameter and about 5' deep. The activated carbon beds are regenerated using 1,000°F superheated steam.

The economic parameters for the FracHOGS' system are determined as follows: the purchased equipment cost is \$2,650,000 and the total capital cost is estimated to be \$17,000,000. This is expensive, but once this investment has been made, money will be saved if the water is reused for stimulation and not sent through the RO system. Based on a three year lifetime of the RO membranes, the total operating costs will be \$1,050,000. With a 5 year payout to equate capital to operating costs, the cost of the clean, potable, directly-dischargeable water is \$10/1000 gal.

The WERC task statement specified that the RO membrane be protected from fouling by the feed stream. The full-scale process is versatile and will eliminate any forms of hydrocarbons present in the feed stream.

INTRODUCTION

Treatment of flowback water from hydraulically fractured shale gas wells is becoming an increasingly important step in gas well production. The flowback water typically contains large

amounts of total dissolved solids (TDS) and other contaminants which render it unsafe to the environment. Consequently, a significant amount of return water is currently disposed of through deep well injection where it is stored safely away from ground and surface water sources. Through proper treatment methods, however, significant amounts of the contaminants can be removed, allowing for reuse of the water in future fracturing operations or other beneficial areas while simultaneously diminishing large volumes of water that would otherwise require deep well injection. It also reduces the demand on surface and subsurface water systems.

Common technologies being implemented for this purpose include thermal distillation and reverse osmosis (RO). Both methods can achieve the desired results, but each comes with a unique set of pretreatment requirements. Task #4 specifically deals with the need for a practical and feasible pretreatment solution for the RO method.

Reverse osmosis utilizes a semi-permeable membrane to separate salt from water, resulting in fresh water recovery rates of 40-90%³. Unfortunately RO membranes are prone to fouling and membrane replacement can be costly. In the case of fracturing flowback water, foulants can include TDS and organic carbons - oils and greases. Therefore, a pretreatment apparatus is required to handle particulates and organics prior to the RO unit to ensure membrane longevity.

TASK PARAMETERS

The design premises specified for the task are:

1. Remove hydrocarbons from the “production water” sample.
2. Sustain RO flux and rejection over a 30 minute period.
3. Minimize waste byproduct and energy use.
4. Maximize ease of operation, reliability, and safety.
5. Upon scale up, supply 1,000 gpm of treated production water to the RO system.
6. The system must be designed to handle a feed of the following composition:
 - a. 3,000 ppm Sodium chloride
 - b. 180 ppm Total Organic Carbon of a hydrocarbon mixture comprised of the following solutions, each accounting for 1/3 of the mixture by volume:
 - i. 67% diesel, 11% Ethanol, and 22% 1-Butanol by volume
 - ii. 67% mineral oil, 11% Ethanol, and 22% 1-Butanol by volume

- iii. 65% Oleic acid (pecan oil was specified; however, FracHOGS used olive oil, which has 55-83% oleic acid content versus 59-75% oleic acid content in pecan oil), 13% Potassium hydroxide, and 23% Methanol by volume exposed to a limited saponification process at 70 C.

TECHNOLOGIES CONSIDERED

There are several water treatment technologies that can be used for industrial water pretreatment before it is sent to a reverse osmosis membrane system. Pretreatment for RO membranes is crucial because it prevents the membranes from being fouled by hydrocarbons, metals and other high or low molecular weight substances in industrial wastewater. For this report, six technologies were considered for the removal of hydrocarbons from water returning from a hydraulic fracturing well: multiple effect evaporation, sand filtration, electrocoagulation, foam fractionation, ultrafiltration and activated carbon bed adsorption.

Multiple-effect evaporation is a process in which water is evaporated in a series of stages with each downstream stage held at a lower pressure than the previous one; because the boiling point of water decreases as the pressure decreases, the vapor from a preceding high pressure stage can be used to provide the heat required by the next low pressure stage. Notwithstanding the fact that this process would completely remove all the water from the fracing fluid, and thus eliminate the need for an RO system for Task 4, its energy and capital requirements make it costlier than those of other technologies that were considered.

Sand filtration is another treatment method used in wastewater treatment throughout the world. Feed water is run through a well packed sand bed and as the water moves through tortuous pathways in the porous sand, the hydrocarbons in the wastewater are captured by different mechanisms such as diffusion, direct collision, and Van der Waals attraction. Sand filtration is often made more effective by adding flocculent chemicals to the feed⁴. Sand filtration was rejected for Task 4 due to disposal considerations for the hydrocarbon-loaded sludge after treatment, high maintenance cost, a massive amount of sand required and because it was not successful in separating the hydrocarbon micelles, which are present in the revised feed stream.

Electrocoagulation is another water treatment method cited in the literature. A current is passed between two metal electrodes immersed in water and this introduces metal cations *in situ*,

thus destabilizing any colloidal particles by the formation of polyvalent metal complexes. These complexes have high adsorption properties which, coupled with a flocculation aided by the evolution of hydrogen gas from the electrochemical reaction, form a foam layer that can be skimmed off the liquid surface⁵. This method was rejected for Task 4 due its sizable energy requirements as well as a lack in the literature of a single systematic or empirical approach to the design of electrocoagulation reactors.

Foam fractionation – widely used for municipal water systems – was considered. Foam is produced by adding a surfactant which causes hydrophobic compounds to preferentially attach to the foam bubbles⁶. The separated chemical species rise in a column of foam which overflows the vessel and is then allowed to disassociate. Foam fractionation was rejected for Task 4 due to the large volume of foam necessary, which caused water loss and the large vessel volume required to break the foam.

Ultrafiltration (UF) is another method widely used today for waste water treatment, especially if the main purpose is the production of drinking water. It is a type of membrane filtration in which hydrostatic pressure forces a liquid through a semipermeable membrane. A literature survey showed that, despite its effectiveness in removing microorganisms, suspended solids and other solutes of high molecular weight, ultrafiltration does not perform well alone when the feed water has high levels of turbidity or high fouling tendencies⁷. Currently manufactured UF membranes can handle 0-5 bars (0-75 psig) pressure. UF is usually coupled with other conventional pretreatment methods (adsorption, coagulation, gravity settling, etc.) for the UF membranes to operate efficiently. Ultrafiltration membranes as a standalone pretreatment were rejected for Task 4. UF membranes are incapable of removing soluble hydrocarbons since they are size exclusion membranes. This left UF alone incapable of meeting the criteria to satisfy Task 4 pretreatment needs.

As discussed above, ultrafiltration is usually combined with other conventional pretreatment methods for optimal efficiency. For Task 4, the FracHOGS decided to use UF combined with carbon adsorption using GAC. The UF feed will be pulled from gravity settled ponds or containment tanks, which are common throughout the oil and gas industry. This settling prior to treatment will diminish the total suspended solid (TSS) in the flowback water, thus significantly reducing the chance that the UF membranes will foul due to large particulates. This hybrid process was chosen for its high efficiency in removing organic molecules in the feed

stream prepared according to the WERC organizers' instructions, its low overall cost compared to the other methods considered and the ability for the carbon to be regenerated for further use. The combination of UF membranes with granular activated carbon (GAC) takes advantage of the high adsorption capabilities of activated carbon and particles removal abilities of UF membranes. Adsorption is a natural phenomenon by which molecules of a dissolved substance adhere to and collect on an adsorbent solid surface. Adsorption is facilitated by a high surface area to volume ratio. Typical commercial activated carbon has a surface area of 1,000 m²/g.

As a contaminated feed stream moves through a well packed bed of activated carbon, a dynamic mass transfer zone – bed depth required to reduce the contaminant concentration to a desired final level – is established at a given flow rate through the carbon bed and when it reaches the exit boundary of the bed, the contaminant appears in the exit stream. This condition is called “breakthrough” and the amount of contaminant adsorbed at this point is the breakthrough capacity. If the carbon bed continues to be exposed to the feed stream after breakthrough, it will eventually reach a saturation point, when no contaminant is being adsorbed on the carbon bed. At this point, the inlet concentration of the contaminant will equal the exit concentration. To take full advantage of the adsorption ability difference between breakthrough and saturation, 2 beds in series were used for Task 4 – one adsorption bed and one guard bed – to allow for the contaminants that pass through the loading bed after break through to be removed in the following guard bed.

The feed stream for Task 4 has some nonpolar molecules which, thanks to a esterification process in the feed preparation procedure, form micelles with polar ends that cannot be removed effectively by the carbon bed (the carbon bed adsorbs only nonpolar molecules) and hence the need for an ultrafiltration step. The feed stream is fed to a UF system which removes the polar micelles and other particulates and the effluent is fed to a GAC bed (two beds in series) where the soluble hydrocarbons are removed.

Another advantage of the UF/GAC hybrid system is that the carbon can be regenerated to be reused in the adsorption process. A literature survey shows that a full scale design of a continuous regeneration process is feasible for Task 4 and its energy requirements are much lower than those of other technologies considered such as multiple effect evaporation and electrocoagulation ¹¹.

BENCH-SCALE APPARATUS

The pretreatment apparatus consisted of a feed tank, feed pump, three pressure gauges, flow meter, three ultrafiltration membranes, two activated carbon beds, and a receiving tank.

Ultrafiltration Unit Design

A 15 gallon bucket was used as the feed tank to supply the surrogate frac water. The water was pumped from the tank using a Procon variable speed, rotary vane pump (102A14011PA) and fed to three Romicon 1" diameter, 18" long, hollow fiber ultrafiltration cartridge, type PM30 (KM84624-5001), distributed by Koch Membrane Systems Inc. The three UF membranes were run in parallel to increase the filtrate flow rate produced by the system. From the ultrafiltration membrane the retentate was continuously recycled to the feed tank while the filtrate was collected in a reservoir before being forwarded to the first of the two in-series activated carbon beds. One pressure gauge was located at the inlet to the ultrafiltration membrane and another at the retentate outlet to monitor the pressure drop across the membrane, generally maintained at ~5 psi. At the pump discharge, there was also a recycle line with a valve that recycled back to the feed tank so that the pressure at the UF inlet could be controlled.



Figure 1. Parallel ultrafiltration membranes.

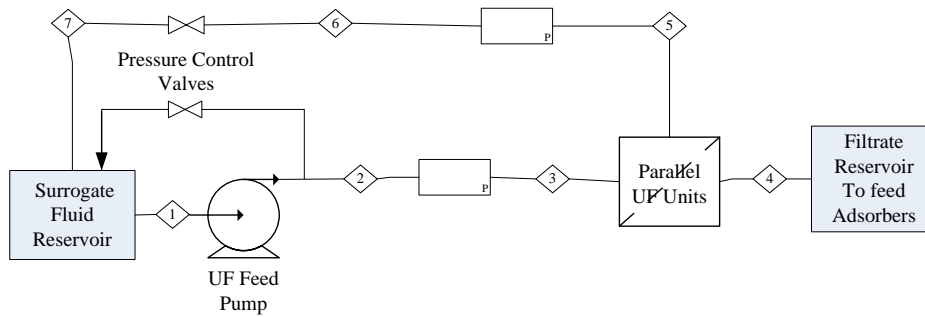

Figure 2. Process flow diagram for ultrafiltration portion of pretreatment.

Activated Carbon Bed Unit Design

Each bed of activated carbon had a height of 30” with a 6” layer of fiberglass at the base for support. The beds were housed in 1” ID Tygon tubes, 52” in length. The apparatus operated with two beds in series. The first bed was loaded past breakthrough, while the second bed acted as a guard to capture the hydrocarbon breakthrough from the first bed. The flow meter and one pressure gauge were attached prior to the first carbon bed so the pressure drop and flow rate across the beds could be measured. While processing a batch of water, small amounts of dispersed oils were able to percolate the carbon bed and collect in the tube connecting the two activated carbon beds. For this reason, a short vertical section of tubing was added with a valve so that the collecting oils could be removed while treating the water.

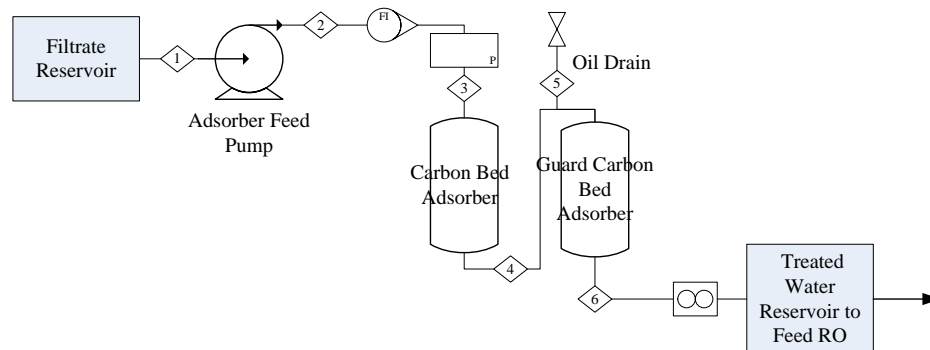

Figure 3. Process flow diagram for activated carbon bed portion of pretreatment.

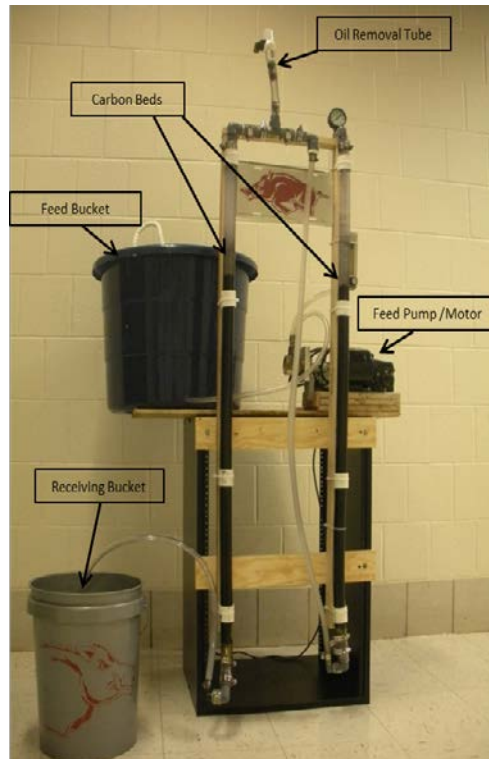

Figure 4. Pretreatment apparatus: ultrafiltration in conjunction with activated carbon beds.

RO Membrane Unit Design

The RO system consisted of a feed tank, feed pump, 2.5" x 12" stainless steel housing, and a permeate tank in addition to the RO membrane itself. Pressure gauges were attached to the inlet and outlet sides of the housing to measure the pressure drop across the membrane. Quarter inch copper tubing was used for both the inlet and retentate tubing. The permeate exited through 1" Tygon tubing. A flow control valve was attached to the retentate outlet tubing to adjust the pressure within the housing. The treated water from the carbon beds was stored in a reservoir tank. This tank served as a feed tank to the RO unit. The feed pump was a Procon, 200 psi, 35 gph, ¼ HP, variable speed rotary vane pump. A pressure gauge and ball valve were attached to a piping-T at the outlet of the pump to recycle flow back to the feed reservoir allowing the pressure at the pump outlet to be adjusted. The outlet for the retentate stream was recycled to the feed tank, while the outlet for the permeate was collected in the permeate tank. The RO unit allowed GE TFM24 Spiral Wound RO membranes to be tested. The pump and steel housing are shown in Figure 5. These membranes were Polyacrylamide, which is the same material used in the GE AG2521TM issued by WERC to be tested. This allowed for

accurate testing of RO membranes without running the risk of fouling the larger, more expensive membranes.

The GE AG2521TM membranes were tested using the same pump and in much the same fashion as the TFM24 membranes. The GE AG2521TM membrane apparatus is shown in Figure 6.

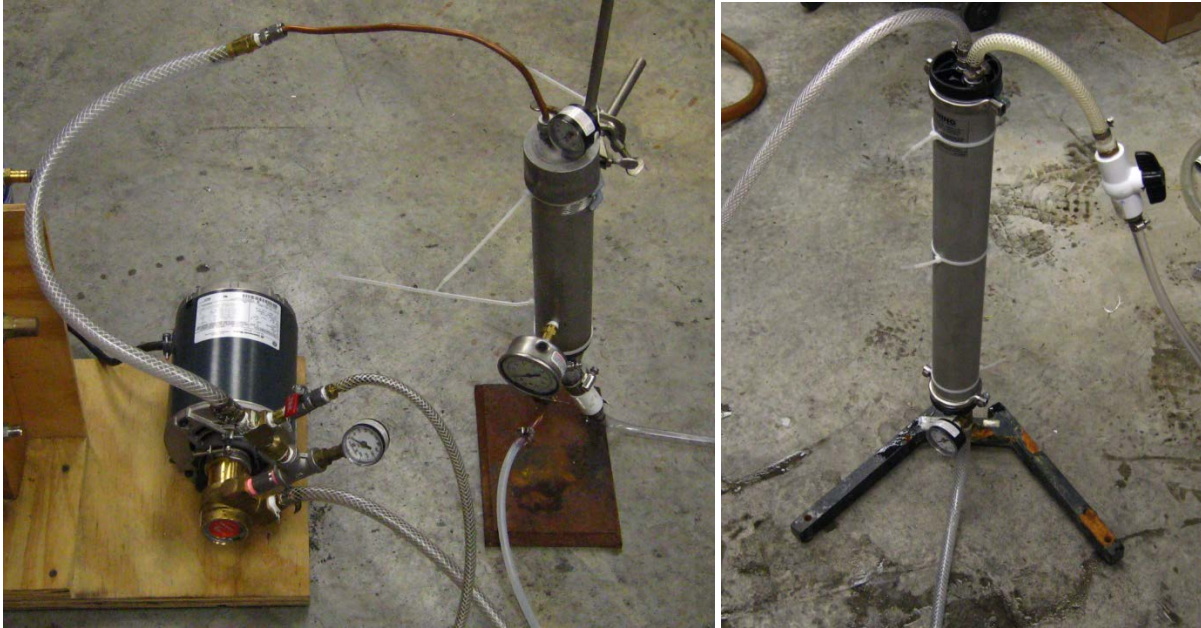

Figure 5. Apparatus for the GE TFM24 membrane shown on left. GE AG2521TM apparatus on right.

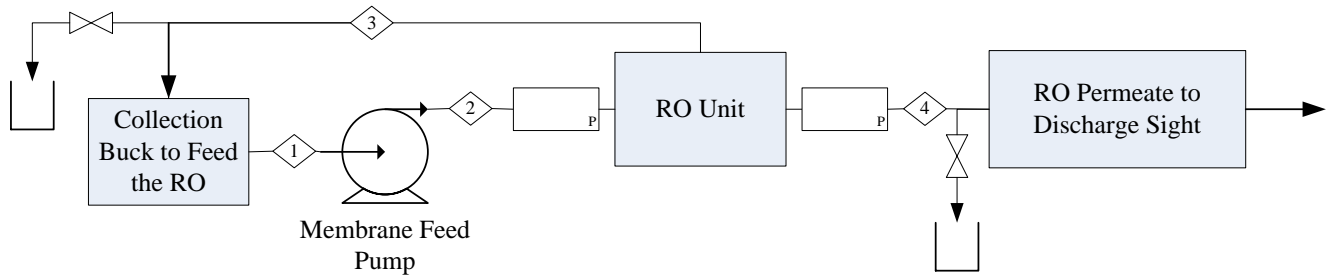

Figure 6. Laboratory RO unit process flow diagram.

BENCH-SCALE OPERATION

In order to test the effectiveness of the pretreatment apparatus, a procedure was developed to measure the amount of fouling induced by the apparatus' product water.

The feed mixture was created using the procedure outlined by WERC⁸. This feed solution was pumped through the three UF membranes in parallel. The filtrate from these UF membranes was then pumped through the two activated carbon beds in series. The RO feed reservoir was filled with water from the activated carbon bed outlet stream. Using the system

described above (RO design), the water was circulated by and forced through a RO membrane. The flow rate of the permeate stream was measured every two minutes for thirty minutes. Any significant decrease in permeate output or increase in retentate output was thought to be due to fouling of the membrane by oils retained in the treated water.

The only significant comparison of the RO performance was that of the flux for the 3000ppm salt water and the treated feed solution. If our process removes all hydrocarbons as expected, the resulting water will only contain the 3000ppm NaCl that was initially added. Thus the membrane flux should be very similar between the 3000ppm salt water and the treated water. Comparison of the treated feed to DI water was deemed irrelevant because the membrane flux for DI water is not comparable to the treated solution. This is due to the fact that DI water will not have any osmotic back pressure from salt, which decreases the flux. It was known that the salt would be retained through the pretreatment so the most accurate comparison with the treated solution would be the 3000ppm solution with the lower flux from osmotic pressure rather than the higher flux from pure DI water.

UF and carbon treatment resulted in no significant decrease in RO membrane performance, indicating that all components which would foul the RO membrane were removed by the combination of UF and carbon bed adsorption.

LABORATORY EXPERIMENTAL RESULTS

Initially, the feed solution outlined by our task only included 3,000 ppm NaCl and 180 ppm hydrocarbon. The hydrocarbon additive was comprised of 50/50 by volume diesel and mineral spirits. When this feed was ran through the RO instant fouling occurred. In fact, the membrane was completely fouled within 10 minutes of operation. The majority of hydrocarbons present in this mixture were in a dispersed phase, because the solubility limit of typical hydrophobic hydrocarbons in water is about 20-60 ppm. By means of GAC pretreatment, almost all of the hydrocarbons were removed and the RO maintained its original flux. However, the task was altered to require treatment for a completely different feed solution⁸. The specifications for this new solution are outlined in “Task Parameters” above. Upon initial testing of the new feed solution, it was surprising to discover that without any pretreatment it in fact did not foul the RO membrane. This is evidenced by the steady flow rates reported in Figure 7 below. The new solution produced hydrocarbons that were present in micelles, evidenced by the statement from WERC “*The Production Water will be composed of microscopic micelles (majority size 0.25 -2*

μm in diameter) of the two hydrocarbons formed from a three part mixing process listed below"⁸; therefore the hydrophobic aspects of the molecules were being contained within a hydrophilic layer. This hydrophilic layer made it possible for the hydrocarbons to flow by the membrane instead of attaching, thereby fouling it, which means they were coming out in the retentate stream. Though the permeate was still a flow of pure water, this meant the retentate would require disposal, removing the possibility for recycling the brackish retentate for future fracking. FracHOGS' GAC treatment works by adsorbing hydrophobic molecules, so other methods had to be considered to remove the micelles from solution. After multiple failed attempts to rupture the micelles via pH and temperature changes, dilution with water, increased salt concentration, and various other surfactant additives it became apparent that size exclusion would be the only effective method for removing the micelles. UF treatment preceding the GAC treatment proved to be capable of removing all micellular hydrocarbons, as shown by Figure 7.

As can be seen in Figure 7, the feed solution, even when untreated, does not cause any fouling of the RO membrane within 30 minutes of operation. This is due to the micelle formation which provides a level of protection for the membrane from possible foulants within the solution. The micelles form because the hydrophilic hydrocarbons preferentially interact and congregate together forming an outer hydrophilic layer encasing the hydrophobic center. This hydrophilic layer prevents the hydrocarbons from interacting with the membrane surface and prevents the feed solution, containing micelles, from fouling the membrane. As shown in Figure 7, runs for salt solution, untreated feed solution, and treated feed solution all produce very similar fluxes. However, feeding non-micellular hydrocarbons will foul the RO membrane. The originally proposed hydrocarbon mixture of 50/50 diesel and mineral spirits was run through a GE TFM24 RO membrane. The results are shown in Figure 8 and it can be seen how quickly and severely the membrane will foul if not protected. So although the proposed feed solution containing micelles does not foul the membrane in Figure 7, it is still important to ensure no hydrocarbons reach the membrane. The FracHOGS' process will not only remove micelles but the carbon beds are also capable of removing any other hydrocarbons present in the solution to ensure that the RO membrane is adequately protected to prevent fouling.

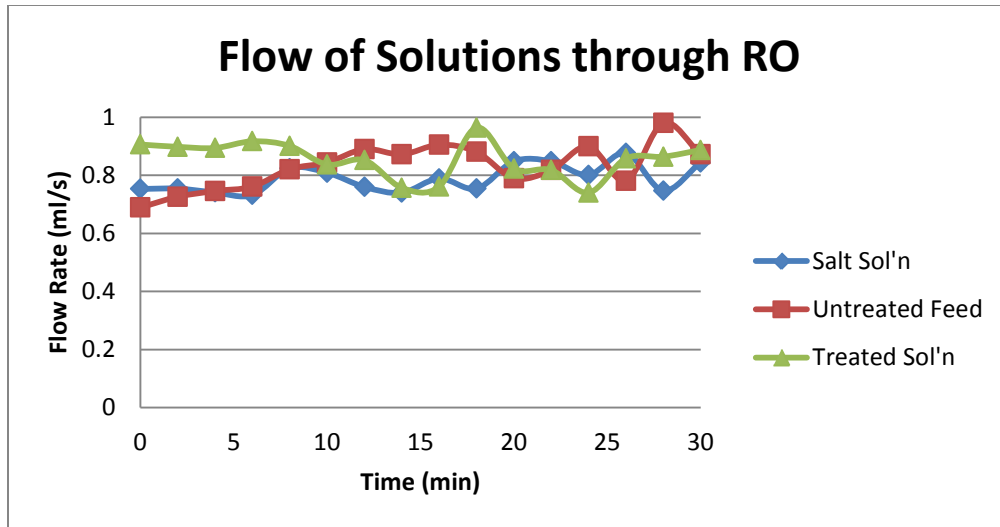

Figure 7. Graph displaying data from various runs, treated and untreated.

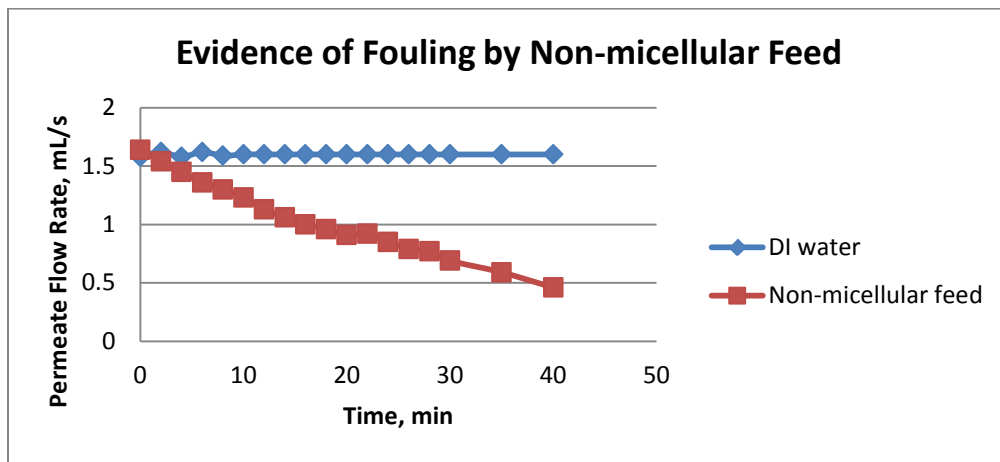

Figure 8. Graph displaying fouling by original non-micellular solution.

Figures 9 and 10 are visual representations of the effectiveness of the UF membranes at removing the micelles, which cause the milky coloration in the water.



Figure 9. Comparison of treated water by UF (left) to the original feed solution (right) prior to treatment. Note: there is a quarter in both samples.



Figure 10. Comparison of UF-treated water (left) to the original feed solution (right) prior to treatment. Note: The samples in this picture are the same as those featured in figure 9, demonstrating that there was not a disproportionate depth of the two solutions.

FULL-SCALE DESIGN

The full scale process flow diagram is given as Figure 11. The equipment for the full scale system will consist of (1) a 3,000 gpm, 100 hp centrifugal feed and recirculating pump which takes feed from an existing feed lagoon, (2) a 3/15 array of hollow-fiber ultrafiltration membranes to handle 1,000 gpm of permeate flow, (3) four 7' diameter by 7' straight side (2,500 gal) 304 SS granular activated carbon vessels, (4) a steam generator for the carbon bed regeneration, (5) a shell and tube steam superheater heat exchanger and (6) a shell and tube condenser to handle condensation of the regeneration steam.

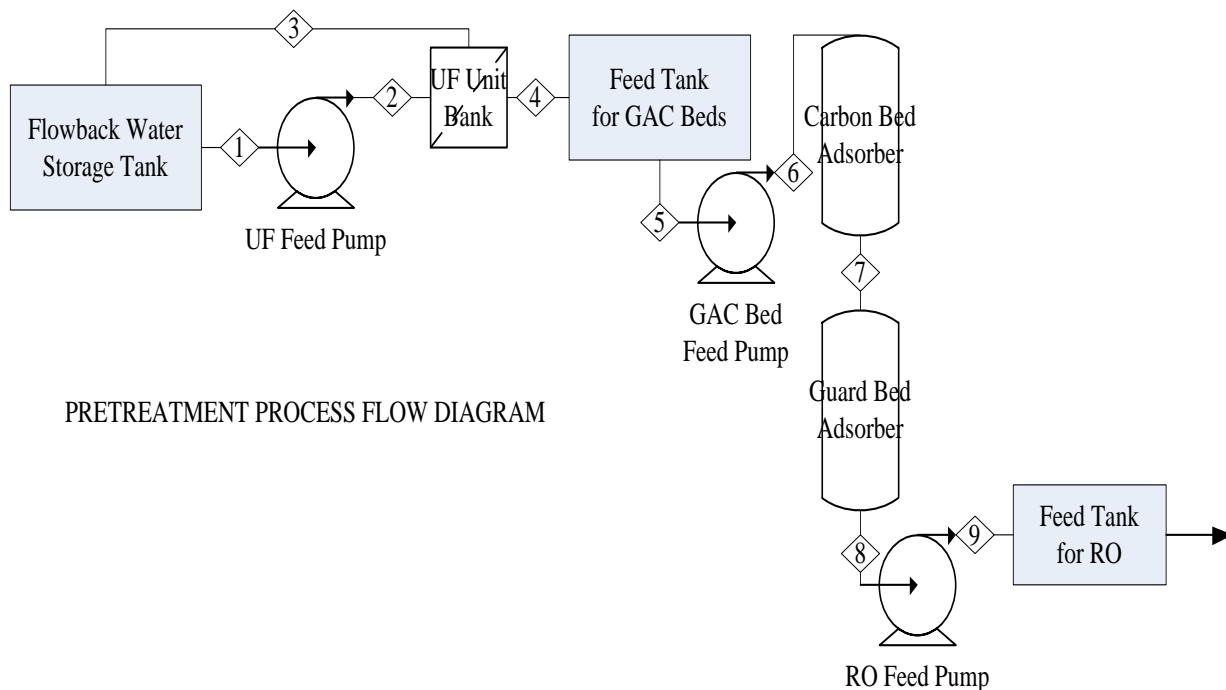

Figure 11. Full Scale process PFD and regeneration PFD

Ultrafiltration

The hollow-fiber ultrafiltration will be configured in a multi-unit array. The UF bank will contain sufficient membranes, assuming 90% recovery (i.e., 90% of the feed permeates the membrane), to handle 3,000 gpm of recirculated flow and 1,000 gpm of filtrate flow. The UF membranes will be operated at ~25 psi inlet and ~20 psi outlet pressures. The retentate of all UF membranes will be retained in a storage feed lagoon as the UF unit removes clean water as permeate. The feed lagoon can be operated to accept fresh feed and/or to have decreasing volume with no fresh feed. No matter the mode of operation with regard to the rate of fresh feed to the feed lagoon, the feed lagoon must be emptied when the concentration of rejected species builds to a level which significantly reduces the permeate flow; a significant permeate flow decrease is not expected to occur until 90% recovery has been achieved.

Based on literature data a bank of 15 (in a 3 x 5 array) SFP-2880 modules (829 ft²/module for a total membrane area of 12,500 ft²) will handle 1,000 gpm of filtrate with a recirculation rate of 3,000 gpm^{9, 10}.

Granular Activated Carbon Beds

Four granular activated carbon beds (each 7' diameter 304 SS vessels with 5' of carbon bed depth) will be used to adsorb any soluble hydrocarbons which pass through the UF units. Two of the beds will always be operated as an adsorption train with the leading bed (bed 1) operating in a fully loading adsorption mode and the following bed (bed 2) operating in a guard mode. When breakthrough occurs in the leading bed the leading bed will be switched to standby regeneration mode (bed 3) and the guard bed will be switched to the adsorption mode. The bed in the standby regeneration mode will be switched to regeneration mode (bed 4) after the current regeneration bed has been cooled and switched to the guard bed. The sequencing for a given bed will be done with automatic valving. For a particular bed this is the sequence of events as it is moved through one complete cycle:

- 1) Adsorption, 2) Standby Regeneration, 3) Regeneration, 4) Cooling, 5) Guard, and 6) Then back to Adsorption.

Carbon Regeneration

In 1978, the EPA did a study on regenerating activated carbon¹¹. That study coupled with the experimental work done here was the basis for the full scale design. The loaded beds must be regenerated. The regeneration is accomplished by heating the beds by superheated

steam to about 1000 F. By the time that the beds have been heated to 1000 F, all the hydrocarbons will have been desorbed from the carbon. Each carbon bed is about 2,000 gal and contains about 16,000 lb of granulated carbon. With a specific heat of 0.17 Btu/lb F about 3,000,000 Btu will be required to heat the carbon and about 5,000,000 Btu will be required to evaporate the contained water. One bed will be regenerated about every 12 hours, giving a maximum duty of the boiler of 700,000 Btu/hr. The beds must be cooled after regeneration and much of the cooling will be done by the cooling of 212 F steam; at least 25% of the maximum duty will be decreased by cooling with atmospheric steam, giving a required boiler duty of about 500,000 Btu/hr. The regeneration PFD is shown in Figure 12. The regeneration of the beds will be accomplished as follows:

1. The loaded bed will be taken out of the loading adsorption mode and moved into the regeneration mode.
2. Compressed air will be used first to strip as much feed solution as is practical from the carbon bed.
3. Superheated steam will be introduced; it will initially condense and heat the bed. The condensate will be routed back to the feed lagoon. After the condensate ceases to flow from the heated bed, the steam exiting the heating bed will be used to cool the bed which has just been regenerated.
4. Superheated steam will be fed to the bed until the temperature reaches about 1,000 F at which time the bed will be switched from the regeneration mode to the cooling mode.

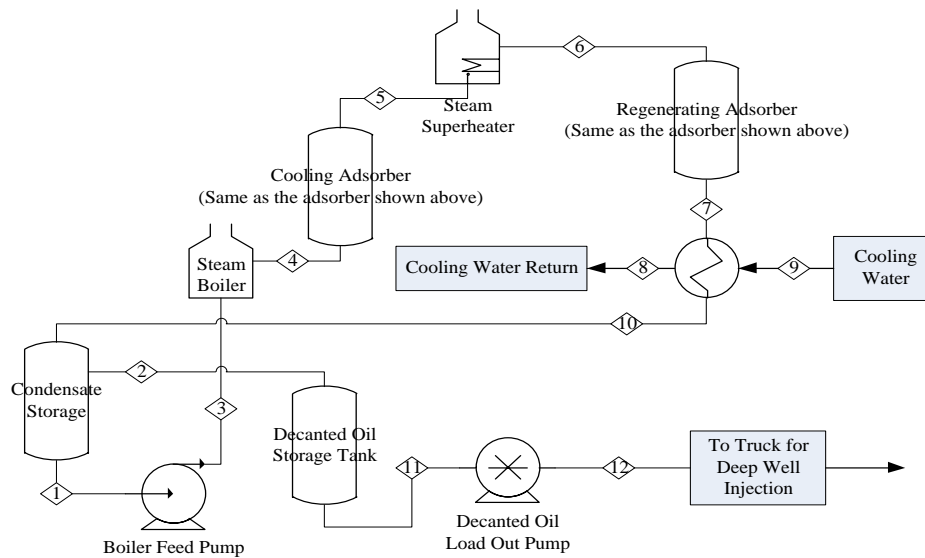

Figure 12. Carbon Regeneration PFD

Logistics

Extensive use of trucking is one of the major cost, safety, and environmental considerations of fracking operations. According to an investigation conducted by Baker Hughes, supported by Figure 13 below, trucking accounts for 60% of the total cost associated with water acquisition and treatment. Their investigation concluded there would be significant savings for using pipelines in place of trucking, as shown by Figure 14.

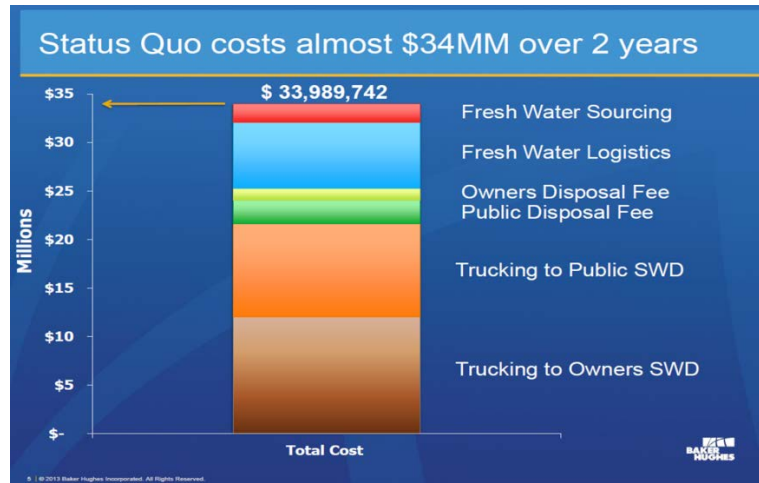

Figure 13. Analysis of typical costs for water acquisition and treatment in the fracking industry¹²

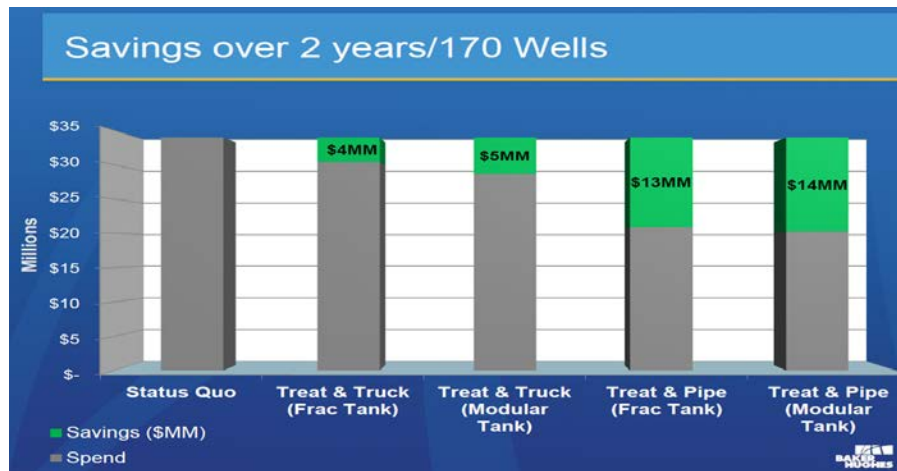

Figure 14. Total savings of using piping versus trucking to service 170 wells over a 2 year period¹².

Proper implementation of the FracHOGS' pretreatment process will decrease the energy industry's trucking reliance. Produced water from all the wells within an appropriate radius would be piped to a central processing location. There, FracHOGS treatment trucks, one equipped with the activated carbon beds, another with a superheated steam bed regeneration

system, and another with the desalination RO elements, would treat the produced water. The brackish retentate would be stored in an additional holding tank where, preferably, it could be piped to new wells and used again for hydraulic fracturing. The permeate stream is sufficiently pure for direct discharge to nearby water ways or any other location requiring potable water, including farm ponds, whatever the most efficient means may be. FracHOGS' treatment trucks would travel from one central processing location to another, leaving the transportation of fluids to the pipelines instead of trucks, thereby minimizing trucking and maximizing recycling.

The "appropriate radius" for the scope of these holding tanks would have to be determined on a case by case basis depending on the density of wells in a given area. As a suggestion, an average radius might be 2.5 miles. Additionally, the size of the holding tanks would also have to be determined based on situational requirements. In order to treat 1,000 gpm, 160 RO elements of 8" inner diameter and length 40" will be used in parallel. An 10 x 16 array requires a space of 7' x 7'. The UF membrane bank would consist of 15 8" x 80" UF membrane modules in a 3' x 5' array which would easily fit on a flatbed trailer.

The composition of produced water will vary not only among different shale plays, but also within each shale play from well to well. One universal method of pretreatment will not necessarily be the best for every application. However, with the FracHOGS' pretreatment method all TDS but salt would be removed via the ultrafiltration while all TSS will be adsorbed in the carbon beds, leaving only salt to be removed from the water going into the RO membrane.

Carbon Regeneration

In 1978, the EPA did a study on regenerating activated carbon ¹¹. It was shown that all activated carbon could be regenerated when heated to 1000°F. This result was proven using an apparatus constructed in the University of Arkansas Chemical Engineering Shop. The device is a cylinder wrapped in heating elements. The deactivated carbon was placed inside of the cylinder. Nitrogen was used to purge the system as the carbon was being reactivated. The system was heated to 1,000 F. The bed was purged with 10 vessel volumes of nitrogen to desorb the hydrocarbons. Upon regeneration the carbon weight was the same as the weight of carbon used to load the hydrocarbon by being agitated in a beaker containing the feed solution.

ECONOMIC ANALYSIS

Table 1. Economic Breakdown of full scale process.

EQUIPMENT COSTS		
	Basis	Cost (\$)
Pumps	Manufacturer	150,000
UF Trailer	Manufacturer	500,000
Carbon Bed Trailer	Manufacturer	1,500,000
Boiler and Condenser	Manufacturer	500,000
Total Purchased Equipment Cost		2,650,000
DIRECT COSTS		
Purchased Equipment Cost		2,650,000
Purchased Equipment Delivery	10% of Purchased Equipment Cost	265,000
Purchased Equipment Installation	47% of Purchased Equipment Cost	1,245,500
Instrumentation and Controls	36% of Purchased Equipment Cost	954,000
Piping	75% of Purchased Equipment Cost	1,987,500
Electrical Plus Automation systems	100% of Purchased Equipment Cost	2,650,000
Total Direct Plant Costs		9,752,000
INDIRECT COSTS		
Engineering and Supervision	100% of Purchased Equipment Cost	2,650,000
Construction Expenses	41% of Purchased Equipment Cost	1,086,500
Legal Expenses	4% of Purchased Equipment Cost	106,000
Contractor's Fee	22% of Purchased Equipment Cost	583,000
Total Indirect Plant Costs		4,425,500
Fixed Capital Investment (FCI)	Sum of Direct and Indirect Costs	14,177,500
Working Capital	10 % of FCI	1,417,750
Total Capital Investment	Sum of Fixed and Working Costs	<u>15,595,250</u>
ANNUAL OPERATING COSTS		
Utilities	Cooling Water, Steam, Power, etc	100,000
Operating Labor Costs		250,000
TOTAL OPERATING COST PER YEAR		<u>1,050,000</u>

REGULATIONS

Environmental Considerations

The main governing party for hydraulic fracturing operations is the Environmental Protection Agency (EPA). The EPA passed two critical acts in the protection and preservation of water within the United States. First, the Clean Water Act (CWA) was enacted in 1972. The CWA establishes the basic structure for regulating discharges of pollutants into the waters of the United States and regulating quality standards for surface waters¹³. The CWA is currently regulating all surface water involved in the hydraulic fracturing industry. Our technology will abide by all previously established regulations of the industry. Prior to treatment with our system, all produced water will be stored at central processing locations in steel containment tanks, which are ubiquitous throughout the fracing industry. This is common practice in industry and complies with the CWA. After treatment from our system, the water can be placed back in containment tanks until it is recycled, or if the appropriate permits are obtained (National Pollutant Discharge Elimination System (NPDES) permit¹⁴), the cleaned water can be discharged to above ground surface water.

Second, the Safe Drinking Water Act (SDWA) was passed by Congress in 1974 to protect public health by regulating the nation's public drinking water supply¹⁵. A core element of the SDWA that regulates the hydraulic fracturing industry is the SDWA Underground Injection Control (UIC)¹⁶. The UIC provides regulations for placing fluids deep underground. A UIC Class II Well is specified to “Inject brines and other fluids associated with oil and gas production, and hydrocarbons for storage.”¹⁷. UIC Class II wells are the predominant disposal method of produced water in the fracing industry, demonstrated by the fact that there are 172,068 UIC Class II wells; this is nearly 150,000 more wells than Class I, III, IV, and VI combined¹⁷. The retentate stream from the UF module may need to be deep well injected, the final use of this water is not determined yet. All other water produced from our treatment system can be either discharged to surface water or reused in hydraulic fracturing operations, eliminating the need for further use of UIC Class II well injection. The only non-recyclable product will be produced from the regeneration of the activated carbon beds. After the steam from regeneration is cooled and separated, the oil layer will require deep well injection. This will all be disposed of in accordance with all previous processes for deep well injection already in use throughout the oil and gas industry.

Our process will use plastic tarp lining beneath our system at the treatment sites, as is currently done on drilling pads and frac operations. This will serve as a method to catch any possible oil spills and leaks from the produced water and retentate stream to avoid any contamination of the site. Our process will continue to follow the protocols of the industry that are already established to prevent oil spills and leaks from entering the environment.

Worker Safety

While prevention and training are the primary safety measures for the proposed system, additional precautions should be considered. Since the system is manually operated, it is of the utmost importance to have operators well trained and familiar with the process. There is not much danger of pressure as the pressure in the system should not exceed about 25 psig, but care should still be taken. The most hazardous portion of the process is the regeneration of the carbon beds. This step will happen at temperature above 1000°F so appropriate personal protection equipment should be worn. This includes eye protection, hard hats, and heat resistant clothing.

Additional Regulations

Due to the potential for the treatment system to be on natural gas well and compression sites, all motors should be approved for explosive environments. Each state has different regulations that need to be considered for use of our system.

The public is always the highest priority and should constantly be considered. It is imperative to maintain a “good neighbor” status with local residents of the oil and gas industry. It should be taken into consideration to not produce excess noise near residential areas, which should not pose a problem for our operation. Trucking is another conflict point between the oil industry and the public, due to the increase in traffic, noise, and dust production. Our process will help to alleviate much of the trucking used in hydraulic fracturing operations, which will help to build a better rapport with the community in oil industry areas.

CONCLUSIONS AND RECOMMENDATIONS

1. The FracHOGS team has determined that ultrafiltration in conjunction with beds of activated carbon is the best pretreatment method for produced fracturing water RO. The process removes particles, including micelles, to 0.005 μm while activated carbon adsorbs all soluble hydrocarbons minimizing the fouling potential of the RO feed stream and prolonging the life of downstream RO membranes.

2. The addition of a second activated carbon bed acts as a guard to the first carbon bed, ensuring that all suspended hydrocarbons would be adsorbed in the event of loading or failure of the first bed.
3. Despite the wide gamut of applications for FracHOGS' pretreatment, all wells will produce water of varying compositions; therefore tests should be conducted to determine the type of pretreatment that will be necessary for that particular case. If the hydrocarbons are only in the suspended phase, not forming micelles, ultrafiltration would be an unnecessary step in the process.
4. The UF units will be trucked to remote sites on one trailer; the carbon beds will also be trucked on one trailer and the regeneration equipment including boiler, condenser, and oil/water gravity separator will be hauled on a third trailer.
5. The total capital cost of the system is estimated as \$15,600,000.
6. The operating cost, including 4 operators is \$250,000/year.
7. With a 5 year payout for the capital, the yearly charges are \$1,250,000/year. With the unit's operating half the time – 4,400 hr/y (263,000 min/y). At 1,000 gpm the water treatment cost is \$10/1000 gal.

REFERENCES

1. Rao, V. (2012). *Shale gas: The promise and the peril*. RTI International
2. National Geographic (March 2013) *America Strikes Oil: The Promise and Risk of Fracking*
3. Alleman, D. (2011, March 29). Treatment of shale gas produced water for discharge. Retrieved from [http://www.epa.gov/hfstudy/17_Alleman - Produced Water 508.pdf](http://www.epa.gov/hfstudy/17_Alleman_-_Produced_Water_508.pdf)
4. United States Environmental Protection Agency (1999). Storm Water Technology Fact Sheet. Sand Filters. Retrieved from http://water.epa.gov/scitech/wastetech/upload/2002_06_28_mtb_sandfltr.pdf
5. Holt, P., Barton, G., and Mitchell, C. (2006) Electrocoagulation as a Wastewater Treatment. Retrieved from http://www.isf.uts.edu.au/publications/PH_GP_CM_1999.pdf
6. Wall, D. (2007) Advanced Chemical Separation Using Foam Fractionation. Retrieved from http://personalpages.manchester.ac.uk/staff/p.martin/publications/Advanced_chemical_separation_using_foam_fractionation.pdf

7. Wenton, I.G. Ultrafiltration in Water Treatment and its Evaluation as Pre-Treatment for Reverse Osmosis System. Retrieved from <http://www.ultraflo.com.sg/images/wenton.pdf>
8. R. Thompson (personal communication, March 6, 2013)
9. <http://www.dowwaterandprocess.com/products/uf/2880.htm>
10. http://msdssearch.dow.com/PublishedLiteratureDOWCOM/dh_07f5/0901b803807f5bda.pdf?filepath=liquidseps/pdfs/noreg/609-02222.pdf&fromPage=GetDoc
11. Robert S. Kerr Environmental Research Laboratory (May 1978) *Thermal Regeneration of Activated Carbon*, United States Environmental Protection Agency
12. Dawson, Kent, and Baker Hughes. "Understanding and Optimizing the Water Management Value Chain." 4th Water Management for Shale Plays. Houston Marriott West Loop by the Galleria, Houston, TX. 26 Feb. 2013. Lecture.
13. "Water Enforcement." *EPA*. Environmental Protection Agency, 12 Sept. 2012. Web. 16 Mar. 2013. <<http://www.epa.gov/enforcement/water/index.html>>.
14. "National Pollutant Discharge Elimination System (NPDES)." *EPA*. Environmental Protection Agency, 12 Mar. 2009. Web. 16 Mar. 2013. <<http://cfpub.epa.gov/npdes/>>.
15. "Safe Drinking Water Act (SDWA)." *EPA*. Environmental Protection Agency, 06 Mar. 2012. Web. 16 Mar. 2013. <<http://water.epa.gov/lawsregs/rulesregs/sdwa/index.cfm>>.
16. "Basic Information about Injection Wells." *EPA*. Environmental Protection Agency, 4 May 2012. Web. 17 Mar. 2013. <<http://water.epa.gov/type/groundwater/uic/basicinformation.cfm>>.
17. "Classes of Wells." *EPA*. Environmental Protection Agency, 2 Aug. 2012. Web. 16 Mar. 2013. <<http://water.epa.gov/type/groundwater/uic/wells.cfm>>.

AUDITS

Audit from Doug Melton of Southwestern Energy received March 19, 2013.

Email: doug_melton@swn.com

Phone: (501) 548-6620

Summary of comments:

Good job of looking at the options!

The oil & gas industry usually finds this (Frack) form of spelling to be offensive, as it is usually used by opponents to our business. The preferred forms are: frac, fracing, and hydraulic stimulation.

Instead of “excess fracing water” or “return water” it is correct to use the term “flowback water.”

An additional reason that SWN reuses flowback water is the reduction in demand on surface and subsurface water systems.

Because natural gas liquids are common in other shale plays, they cannot simply dilute flowback water and reuse it, as is the common practice in the Fayetteville shale.

In your process, I would try to catch the oil & grease early on before it hits the carbon. At least try to reduce the volume by gravity separation.

In your process, you should consider using two carbon beds plus a guard bed. The two beds in parallel allow the system to operate while the other is being regenerated.

As the oil & gas industry is heavily regulated, would this system require a permit for air emissions?

Your economic analysis should include permit fees and monitoring fee. Any permit will require extreme monitoring of the discharged water.

Strictly speaking, in all states the privacy for regulating has been assigned to the individual states. In Arkansas it is the Arkansas Department of Environmental Quality.

“Produced water” is completely different than “flowback water” and is regulated differently.

An “oil layer” is not amendable to injection. Separated oil is sent to a refinery for recycling.

25 psig is enough pressure to blow out an eye.

Would carbon regeneration be more practical at a central facility?

Audit by Dr. Robert Cross of the Ralph E. Martin Department of Chemical Engineering at the University of Arkansas received March 27, 2013.

Email: racross@uark.edu

Phone: (479) 464-3177

page 2. 40,000 gallons is much too low. The volume of fluid used for fracking per well is approximately 4.5 million gallons. Approximately 85% of that remains in the ground. I believe the 40,000 gallons you have in the report came from Doug Melton as the volume he had left to treat after the recycling that SWN already does.

page 3. Dilution doesn't remove micelles (emulsified hydrocarbons). Concentration might if the concentration reaches a level where the micelles would coalesce and form a separate layer.

page 6. UF alone wouldn't work because UF doesn't remove dissolved hydrocarbons, not because high pressures can't be used. At 75 psi the flux rate will be very high so there is no need to have higher pressures. Why would Task 4 require higher pressures if UF would do the job.

In you test RO system, your pump can only operate up to 200 psi. Just for your information industrial RO elements would normally be run at much higher pressures (at least 400 psi).

page 11. What you are calling the hydrophilic layer did not pass through the membrane. It is in the retentate.

page 12. You should explain why the salt water flux is lower than the pure water flux. It's because the osmotic pressure of salt water reduces the effective pressure driving force across the membrane.

page 14. With this stream the UF recovery could be at least 80 to 90%, maybe higher. What do you do with the UF retentate after you store it? You will only need to handle a UF feed of 1,250 gpm or less to supply 1,000 gpm to the RO unit. This will require at least 120 8"x40" spiral UF units.

page 16. You don't mention UF as being in one of the trucks.

page 16, 8 lines from bottom. TSS (total suspended solids) and micelles will be removed with UF. The remaining TDS (total dissolved solids) and hydrocarbons will be removed by the carbon beds.

page 16. The RO system will require at least 160 (not 121) 8"x40" elements. RO units are not designed with all elements in parallel. For energy saving there will be at least four elements in series, maybe 6. For further energy savings and to increase the recovery the RO system would be staged. Considering the piping, pumps, controls, cleaning tanks and space necessary to service the unit, it will be significantly larger than 7' x 7' but can probably be put in a large truck.

page 18. Another operating cost is the replacement of the UF elements (3-year membrane life). The cost will be about \$1,000 per element resulting in an annual cost of \$40,000.

page 21. UF will remove particles above 0.005 microns in size

Audit from Rich Plageman of Southwestern Energy received March 25, 2013.

Summary of comments:

Nice work! Very thorough analysis of the options.

Mention the fact that “some testing of other systems to discharge into waterways” has been done.

“Also, SWN uses less fresh water, reducing demand on natural resources” because they reuse the flowback water.

For the reasons against using a sand bed, “is one reason more influential than the other? Could list primary and then secondary reasons.”

“Can the single bed regenerate fast enough for a continual process?” Should use “two adsorption beds before the guard bed.”

“Check volumes based on correct fluid volumes coming back from the well. Will you need more resources (more FracHOGS trucks)?”

Are you going to have “3-4 arrays per 18 wheeler?”

“TAXES!!” are not included in economic analysis.

Engineering and supervision cost is “quite high.”

Did not include “permitting fees!, maintenance requirements, or capital replacements.”

“How many times can carbon beds be regenerated?”

Hydraulic fracturing is “State regulated” by the “AOGC and ADEQ.”

The oil layer can be “recycled not injected.”

“Not plastic (lining beneath treatment sites), Geo fabric which has a definite thickness requirement.”

For worker safety, do you need “gloves? Face shields? Research boiler operation to find safety procedures.”

For references: “SPE papers? There are good, academic resources from the data base.”

