

§12. Effect of External Magnetic Field on CT Injection

Uyama, T., Fukumoto, N., Nagata, M. (Himeji Inst. of Tech. Eng.), Miyazawa, J., Yamada, H.

We have advanced a project to fuel LHD by spheromak-like compact toroid (CT) injection method using SPICA (Spheromak Injector using Conical Accelerator).¹⁾

Application of CT injection for LHD needs a long distance transportation of CT through a drift tube. This is because the CT formation regions of SPICA should be installed away from the LHD vessel. The transportation of CT through the long drift tube is to be seriously affected by the LHD magnetic fluxes that are leaking out from the LHD and intersecting the drift tube.

For the above reasons, we researched a behavior of CT during it was travelling in the drift tube with a vertical vacuum magnetic field. Experiments were carried out in the FACT device at Himeji Institute of Technology as shown in Fig. 1. CT plasma was formed by a magnetized coaxial plasma gun and accelerated by discharge current between coaxial electrodes for CT acceleration.²⁾ The external magnetic fluxes were supplied by a pair of saddle coils installed outside the drift tube and perpendicularly interpenetrated into the drift tube. CT behaviors were measured by five sets of multi-channel magnetic probe arrays and a few electrostatic probes.

We investigated a temporal evolution of CT magnetic field profile at a few positions in the drift tube. Results obtained indicated that CT was decelerated by the external magnetic field, B_{ex} , and came to stop at a certain place, that is a penetration length. This penetration length depends on both of the strength of external field supplied and the velocity, v_{CT} with which CT is injected into the vertical magnetic field, as shown in Fig. 2. We also measured an induced current, J_{ind} in the CT plasma when CT was traversing the magnetic field, using Rogowsky coil. It was measured that J_{ind} flowed across the CT cross-section in the direction of $v_{CT} \times B_{ex}$, and was short-circuited through the drift tube as an external conductor, thus generating the Lorentz force of $J_{ind} \times B_{ex}$, the direction of which was inverse to v_{CT} . Consequently, measurements enables us to estimate that the main deceleration of CT arises from this Lorentz force as illustrated in Fig. 3. If we suppose to cover the drift tube wall with a kind of insulator, then we are able to relieve CT from deceleration.

In addition, we observed that CT shifted in a direction perpendicular both to v_{CT} and B_{ex} during it traversed the vertical magnetic field in the drift tube. Measurements showed that the shift direction of CT was $-v_{CT} \times B_{ex}$ when the polarity of source inner electrode was minus and $v_{CT} \times B_{ex}$ after it became plus. This shift is interpreted in terms of two models. One is discussed on the assumption that CT is carrying with electric charge and is forced to shift by the vertical magnetic field. The other assumed that CT shifts owing to interaction of a current flowing along the central axis of the drift tube with the vertical magnetic field. It is difficult to determine from the present results which of the two models is responsible for this shift.

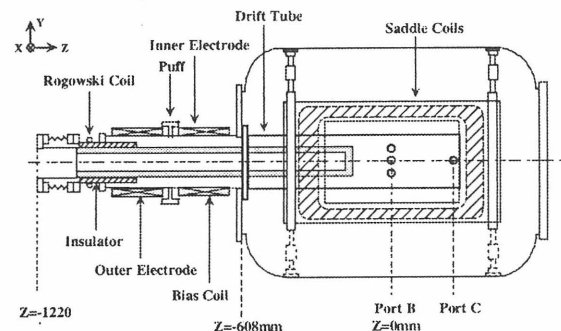

Fig.1. Schematic of the FACT device with saddle coils.

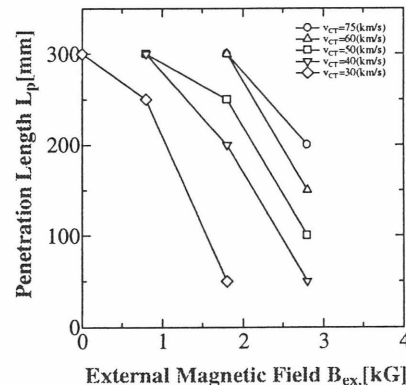

Fig.2. Penetration length of CT vs. External magnetic field.

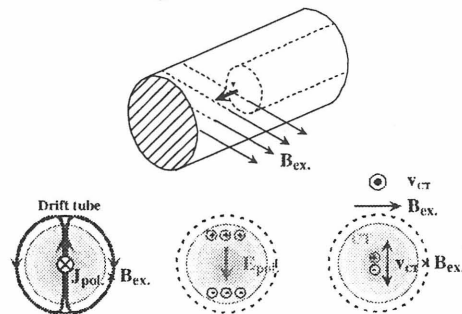

Fig.3. Illustration of CT deceleration.

References

- 1) J. Miyazawa et al., NIFS-614 (1999)
- 2) N. Fukumoto et al., Trans. IEE Japan, 119-A, 11, 1300 (1999) (in Japanese)