

§32. Optimized Thermo-Mechanical Design of High Intensity Neutron Source Test Cell for Material Irradiation

Shimizu, A., Yokomine, T., Ebara, S., Yoshida, N., Matsuo, K. (Kyushu Univ.), Nakamura, H., Yutani, S. (JAEA), Matsui, H., Hasegawa, A. (Tohoku Univ.), Noda, N., Muroga, T., Sagara, A.

For material irradiation tests in IFMIF, temperature control of high accuracy is indispensable since neutron irradiation characteristics of material depend on irradiation temperature strongly. Especially in the high flux test module (HFTM), the space allowed for the temperature control is a little because the irradiation volume is remarkably restricted, and it makes the irradiation test very severe from the viewpoint of heat transfer. We have proposed a test module design that an accurate temperature control and monitor of temperature of irradiated specimens are possible. In our design, by making a cast-like capsule that is irradiation unit and accommodates specimens elongated in the spanwise direction, uniform temperature distribution in the capsule is promoted. A series of heat transfer experiment and numerical analysis and the upgrade of the design have so far been done in Kyushu University.

Since the temperature control of the HFTM is done with the electric heater installed in the capsule and He gas cooling, control of a flow rate and velocity profile of the flowing coolant is necessary to achieve the accurate temperature control. The coolant is supplied from the lower side of the HFTM and it passes through the irradiated region. Its velocity distribution is required to become uniform until it reaches the irradiated region. In addition, the coolant must be distributed equally into four channels in the irradiated region and this must be achieved without applying an independent gas supply system. In this case, because the mechanical device is inapposite under the irradiation environment, it is necessary to hold an accurate distribution of flow rate only by geometrical configurations of the channels. For this purpose, we have been proposing a porous-type manifold which is used as a flow distributor of coolant entering an irradiation region of the module. The manifold is comprised of a straightener part with porous plates located upstream of the irradiated region and a bifurcation part into four cooling channels just before entering the region. Porous plates are considered suitable for mixing the flowing coolant and making its velocity profile spatially uniform even in a short flow path. In this study, we manufacture a mock-up of the manifold and performe fluid flow experiment by varying the porous plates inserted in the straightener part.

Fig. 1 shows a schematic of the test section. The test section is the one as big as the original dimension based on the JAEA test module design, and N_2 is used for the gas. The most controversial part of development of the manifold is whether velocity profiles in the four channels after passing

the manifold become the same. Fig. 2 shows velocity profiles in the measurement part in Fig. 1 in case without porous plates while Fig. 3 shows those which are obtained by using three porous plates. From these figures, it is found that the velocity profiles which are not uniform at all in case without porous plates are well modified by inserting the porous plates and almost uniform over the channel just before branching into four channels. In the experiment, pressure drop by the porous plates is up to about 3 % of the total. Distribution of the flow rate into the four channels is sufficiently achieved, but this is considered due to not the porous plates but a geometrical configuration of the bifurcation part. The porous plates contribute to the velocity profile. The velocity profile can be remarkably changed by the porous plates and made spatially uniform.

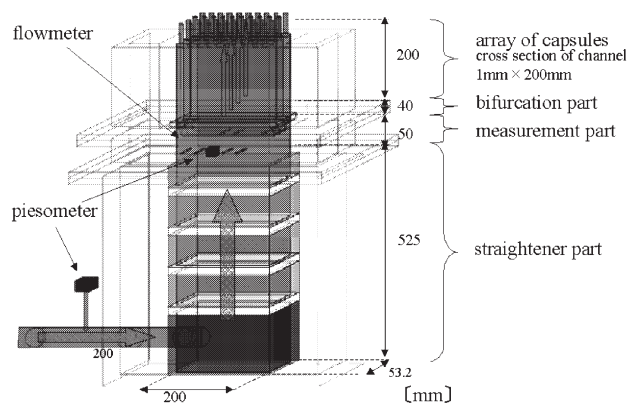

Fig. 1 Schematic view of test section

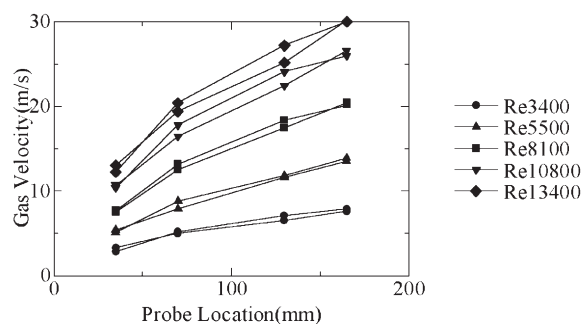

Fig. 2 Velocity profiles in case without porous plates

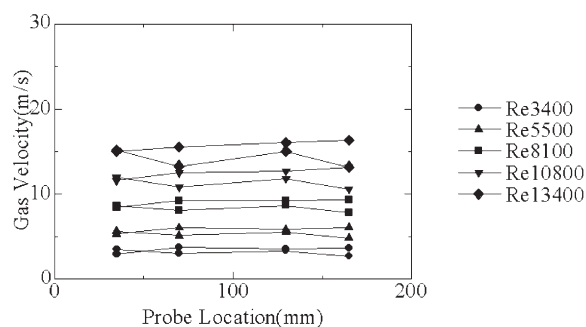

Fig. 3 Velocity profiles in case with porous plates