

§18. Two-dimensional Potential Measurements with HIBP on the LHD

Shimizu, A., Ido, T., Nishiura, M. (Univ. Tokyo), Makino, R. (Nogoya Univ.), Kurachi, M. (Nagoya Univ.), Yokoyama, M., Takahashi, H., Igami, H., Kubo, S., Shimozuma, T., Kato, S., Yokota, M.

In the confinement physics of magnetically confined torus plasma, the structure of radial electric field E_r is important. Plasma flow is correlated to E_r through $E \times B$ flow, and many theoretical researches show that the shear flow can improve the confinement property by reducing the turbulence. Experimental results that support this theory were obtained in good confinement mode, such as H-mode and internal transport barrier (ITB). Flow also influences appearance/disappearance of islands, so it is important for island formation physics. Two-dimensional measurement of E_r is very helpful to study those physics, therefore the method of 2-D potential measurement with HIBP is presented.

In LHD, the probe beam energy of HIBP is usually fixed and the injection/ejection angle to/from plasma is changed to obtain the one-dimensional potential profile¹⁾. If the probe beam energy is changed, we can measure another one-dimensional profile of potential with HIBP. By changing the probe beam energy, two-dimensional potential profile are possible to measure, however, changing the probe beam is not easy. Since the length of beam transport line of HIBP in LHD is about 20 m, so when the probe beam energy is changed, the beam orbit in the beam transport line have to be adjusted. We have many electrostatic deflectors in the beam transport line, and they are required to control to adjust the beam position to the center of the beam transport chamber. In order to adjust the beam orbit automatically, the automatic beam adjustment system is developed. The simple diagram of the system is shown in Fig. 1. The system consists of PC installed ADC board into PCI bus. The beam positions, Δx_i and Δy_i , in the beam transport line are measured by beam profile monitors (BPMs) and data are acquired through ADC. Obtained data are analyzed and required voltages of deflector to adjust the beam position, ΔV_{xi} and ΔV_{yi} , are calculated. The beam positions Δx_i and Δy_i have linear dependence on deflector voltages ΔV_{xi} and ΔV_{yi} , therefore, the relation between these parameters is expressed as follows,

$$\begin{pmatrix} \Delta x_1 \\ \Delta y_1 \\ \Delta x_2 \\ \Delta y_2 \end{pmatrix} = \begin{pmatrix} A_{11} & A_{12} & A_{13} & A_{14} \\ A_{21} & A_{22} & A_{23} & A_{24} \\ A_{31} & A_{32} & A_{33} & A_{34} \\ A_{41} & A_{42} & A_{43} & A_{44} \end{pmatrix} \begin{pmatrix} \Delta V_{x1} \\ \Delta V_{y1} \\ \Delta V_{x2} \\ \Delta V_{y2} \end{pmatrix}. \quad (1)$$

Here, the transport matrix, A_{ij} , can be calculated from theory, but the coefficients obtained from calibration experiments are used in the actual optimization. The required voltage to shift the beam position to the center of beam transport line can be calculated by using the inverse matrix of A_{ij} , as

$\Delta \mathbf{V} = \mathbf{A}^{-1} \Delta \mathbf{x}$. The calculated voltages for power sources of deflectors are applied through DAC modules in CAMAC, which connected with GPIB controller to PC. After new parameters are applied to deflectors, once more positions of probe beam are measured with BPMs and the next optimization loop is repeated. When the distances of beam from the axis of the beam transport line become less than 1 mm, the optimization process stops. By using the automatic beam adjustment system, the required time to adjust the beam can be reduced to within 3 minutes, while it takes a few ten minutes without this system.

By applying the automatic beam adjustment system, the probe beam energy is changed shot to shot, and two-dimensional potential profile is measured in LHD. The obtained 2-D profile of equilibrium potential is shown in Fig.2. From 7 similar shots, potential profile is measured with different probe beam energy. In the inner region, plasma potential profile is flat, which coincides with the electron temperature profile from Thomson scattering diagnostics. In the future, we improve S/N ratio to study the effect of 2-D E_r structure on islands and fluctuations.

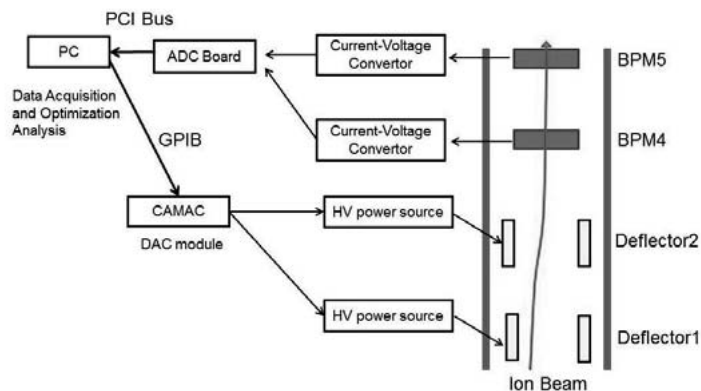

Fig. 1. Simple diagram of automatic beam adjustment system is shown.

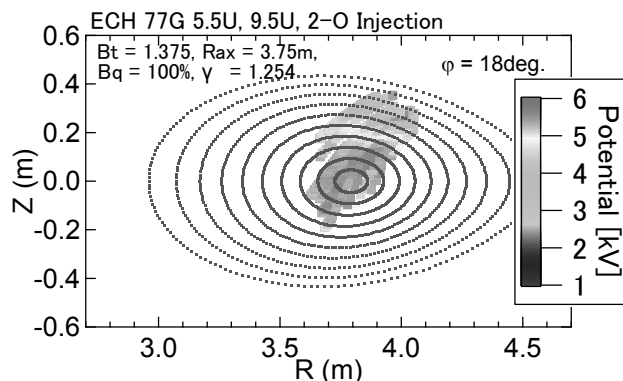

Fig. 2. Obtained 2-D potential profile with HIBP from 7 shots, by changing the probe beam energy

1) Shimizu, A., Ido, T., Nishiura, M. *et al.*: J. Plasma Fusion Res. **5** (2010) S1015.