

## §17. In-situ Diagnostics of CO<sub>2</sub> Gas Generated in the Microwave Carbothermic Reduction by Using the Laser Absorption Spectroscopy

Matsubara, A., Nakayama, K., Okajima, S. (Chubu Univ.),  
Takayama, S., Sato, M.

The microwave-heating technology accumulated through the nuclear fusion research has contributed to the field of industrial microwave processing. One of the innovations is microwave iron making<sup>1)</sup>. The energy required for carbothermic reduction of iron ore is supplied as microwave. Thus, the microwave iron making allows to reduce the consumption of carbon by half from the level in the blast furnaces, if the electric power for the microwave is generated by carbon-free energy such as nuclear power. The precise amount of the carbon consumption is governed by the reduction process. There can be three processes in the reduction from magnetite to wustite<sup>1)</sup>:

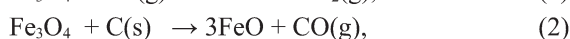
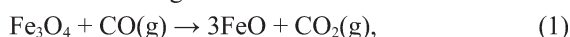

The carbon consumption for the process of eq. (1) is inherently larger because of the loss of CO by gas diffusion. The carbon utilization in reduction process is twice higher for eq. (3) than that for eq. (2).

In order to reveal predominant process in the carbothermic reduction, the in-situ gas analysis with a CO<sub>2</sub> laser absorption spectroscopy (LAS) was employed. Fig.1 shows the experimental setup for the microwave material irradiation and the LAS diagnostics system. The specimen made of magnetite and graphite powders was heated by E-field of microwave at 2.45 GHz in the TE<sub>103</sub>-single mode cavity depicted as SMC in Fig. 1. In this experiment, a two wavelength LAS was performed in consideration of the temperature effect. The temperature dependence on the transmissivity is different between 9- $\mu\text{m}$  and 10- $\mu\text{m}$  bands, because the lower state of the transition is higher for 10- $\mu\text{m}$  than that for 9- $\mu\text{m}$ . Thus, it is expected that the two wavelength LAS give simultaneously us both temperature and concentration of CO<sub>2</sub>.

Fig. 2 shows various time evolutions measured during the heating. There are three stages associated with the change of phenomena, depicted as I - III on the upper axis of Fig. 2(a):

- I.  $t = 47 \text{ s} - 121 \text{ s}$ , namely pre reduction-dominated stage, characterized by microwave direct volumetric heating.
- II.  $t = 121 \text{ s} - 210 \text{ s}$ , namely the reduction-dominated stage, characterized by the large scale discharge plasma and significant exhaust gas generation.
- III.  $t = 210 \text{ s} - 574 \text{ s}$ , namely the post reduction-dominated stage.

These stages are equivalent fundamentally to that found in previous experiments for microwave iron making<sup>1,2)</sup>. In the stage I, the transmissivities begin to decrease slightly from 1.00 to  $0.96 \pm 0.01$ . Comparison with theoretical transmittance, the most probable set of temperature and volume mixing ratio are inferred as  $\sim 300 \text{ K}$  and  $\sim 0.4$ . The

evidence of the laser-absorption is provided partially by the trace of the beam position of He-Ne laser as shown in Fig. 2(b). The generation of CO<sub>2</sub> at the stage I concluded from the laser analyses indicates that considerable process in the pre-reduction is attributed to the process given by eq. (3). The present in-situ LAS ensures the existence of pre-reduction found through exhaust gas analysis performed in prior experiments.

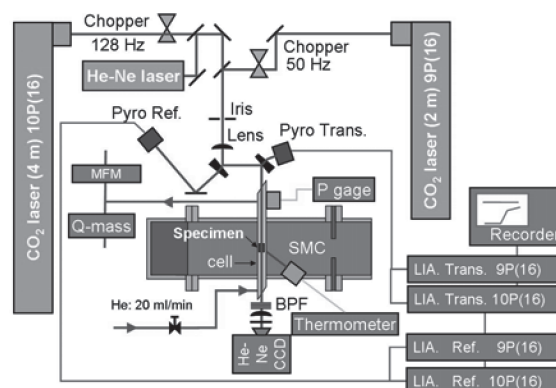

Fig. 1. Experimental setup of the microwave heating in the single mode cavity (SMC) and the LAS diagnostics system.

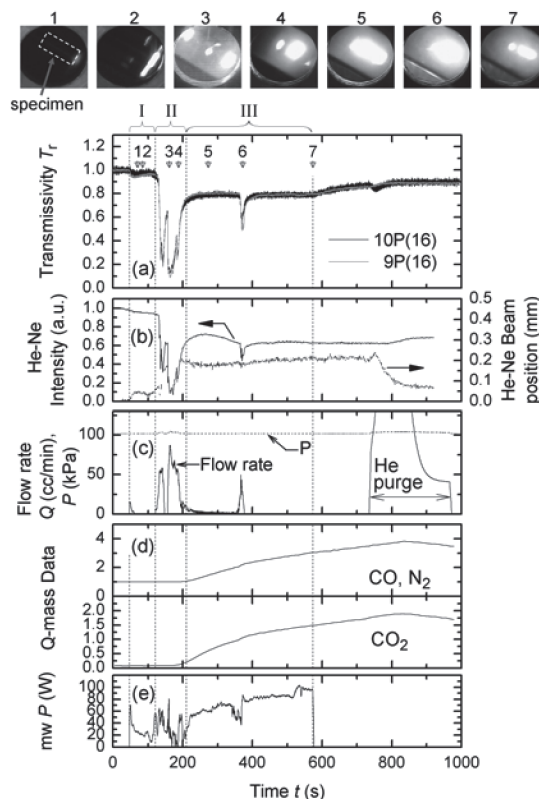

Fig. 2. Various time evolutions measured during the microwave carbothermic reduction of magnetite. CO<sub>2</sub> laser transmissivities in (a). Intensity of the transmitted He-Ne laser and its beam position in (b). Flow rate of exhaust gas and gas pressure in (c). Component intensity in CO and CO<sub>2</sub> measured by Q-mass in (d). Net absorbed power into the cavity in (e).

1) Nagata K., et al.: Proceeding of Int. Cong. Sci.&Tech. Steel Making (Gifu 2008) in press.

2) Matsubara A., et al.: PFR 3 (2008) S1085.