

§4. Performance of the LHD Cryogenic Control System

R. Maekawa, T. Mito

Cryogenic system for the LHD has been developed to provide reliable and safe operation. (1) Infrastructure of LHD cryogenic control system (TESS) is a combination of distributed control system with an integrated controller linked by multiple LANs, as shown in Fig. 1. The integrated controller shared information with four subsystems: a helium refrigerator/liquefier; a helical coil; a poloidal coil and a superconducting bus-line, via reflective memories. Each subsystem has a VME controller and a workstation for its process control. The system utilizes redundancy, a duplex system, for fault-tolerance. Operating graphic console units, DP-1000, are man-machine interface which adjust parameters for PID control loops, monitor process values and so on.

The LHD-cooldown scenario, approximately one month operation, is carefully considered to maintain temperature gradients in the system within a tolerant level (50 K). Cooldown processes of each subsystem are implemented independently by the temperature levels. Sequence programs are developed to change cooling mode for subsystems corresponding to their temperatures. Program Control Unit (PCU) proceeds cooldown process from ambient temperature to approximately 80 K in terms of changing a supply helium gas temperature for -0.8 K/hr. During this process, mass flow rates for subsystems are adjusted from the integrated control unit.

Temperature distributions in subsystems are monitored and reported to the integrated controller. Once the temperature gradients exceed the tolerant level, a cooldown process is interrupted until the condition becomes clear.

To increase the reliability and availability of system operation, the system needs to take corrective action against failures, such as, a coil quench, software crash, power loss and deterioration of vacuum insulation. Sequence programs have been developed for the case of these failures. For instance, in the case of coil quench, an integrated controller sends command to subsystem to interrupt PID loop control and/or sequence programs to execute emergency sequence programs to prevent any damage to the apparatus. In other words, supply lines from the helium refrigerator are changed to bypath cooling objects. These programs are executed based upon operating currents of the superconducting coils, which in turn prevent any fault quench signal to run emergency programs.

Despite the limited preparation time, LHD-TESS demonstrated a reliable operation during the first cooldown, steady state operations and in the case of emergency. Cooldown scenario is proved to be working well, however, it still needs some modification to establish automatic operation. Sequence programs for quench were also tested for 1T operation with a dummy signal, which ensured the continuous operation of refrigerator and the PID control of cooling objects.

Reference

- 1) Mito, T., et. al. Proc. CEC/CEC 16, 1, (1997) 79

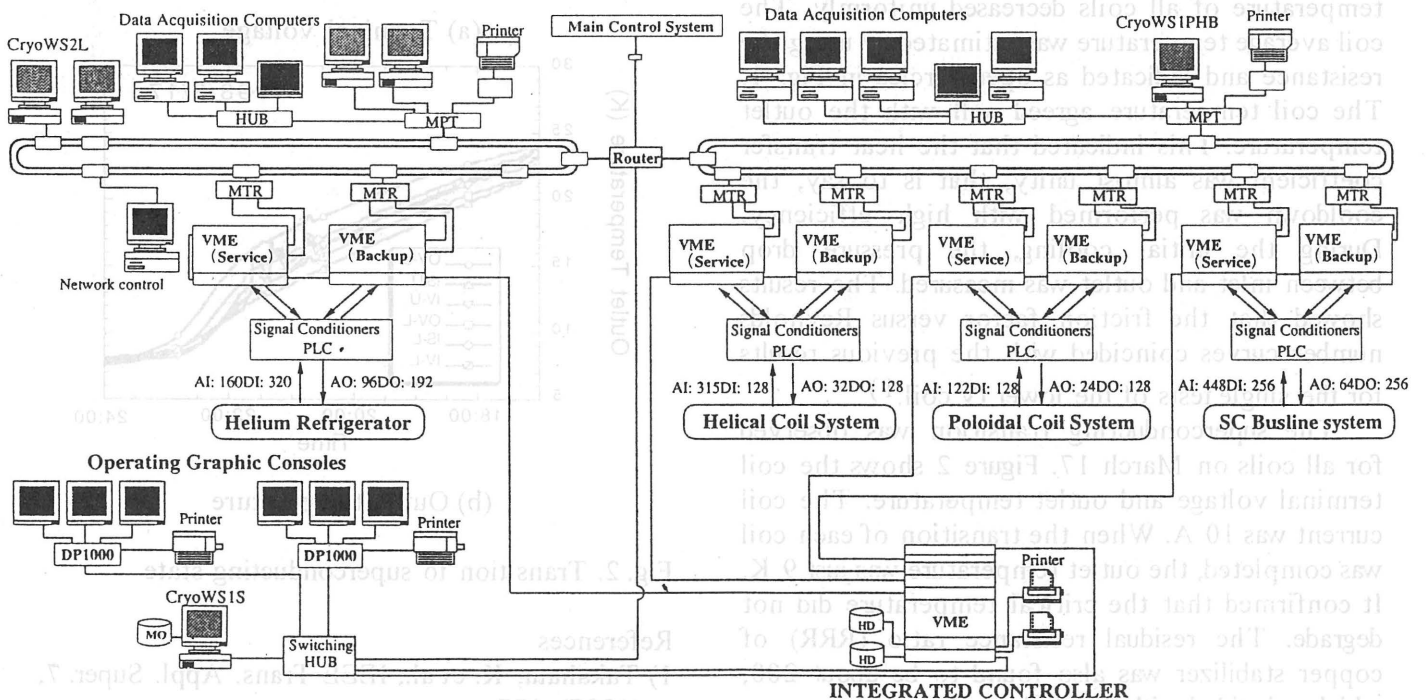

Fig. 1. LHD Cryogenic Control System