

Kusano, K., Suzuki, Y., Nishikawa, K.
(Dept. Mater. Sci., Hiroshima Univ.)

While solar flares are believed to be a catastrophic liberating of the magnetic energy in the solar corona, even an elementary question is still open; *'why does it occurs such as a catastrophe?'* Recently, we tackled this problem based on the MHD relaxation theory, and developed the bifurcation-transition flare model [1], which explains flares as a transition dynamics between the bifurcated linear force-free fields (LFFF). In the current study, we have improved the theoretical model, and try to specify which type of catastrophe might be involved in flare dynamics.

First, we carefully reconsidered the solution structure of the solar coronal arcades in the LFFF, and clarified that two different modes can cause the bifurcation; the symmetric mode (SM) which has a zero wave vector, and the undulating mode (UM) which has a nonzero wave vector parallel to the magnetic neutral lines [2]. Depending on the geometry and the magnetic helicity, the minimum energy state is switched among three different solutions of the LFFF: the coupled solution (CS) which totally coupled with the potential field, the mixed solution (MS) which is composed of the CS and the SM, and the MS of the CS and the UM.

Secondly, we investigated the stability of the CS, and revealed that, once the bifurcation happens, the CS is always unstable against the mode leading to the bifurcation (Figs.1 & 2) [2]. This result implies that the system must be linearly unstable as long as the free energy exists, and thus there is no meta-stable state. Based on these results, we proposed that the pre-flare phase is controlled by the competition between the growth of the instability and the helicity injection due to the photospheric motion. This is consistent with the simulation result which shows that the catastrophic feature of the energy relaxation is caused by a nonlin-

earity in the current sheet formation process, rather than a *'loss of equilibrium'* dynamics.

References

- 1) Kusano, K., Suzuki, Y., and Nishikawa, K.: *Astrophys. J.* **441** (1995) 942.
- 2) Kusano, K., and Nishikawa, K: *Astrophys. J.* **461** (1996) 415.

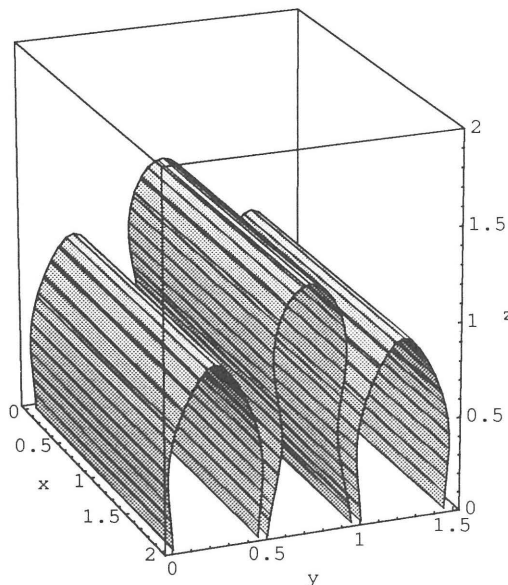

Fig.1: The iso-flux surfaces of the magnetic arcades which are modified by the symmetric mode instability.

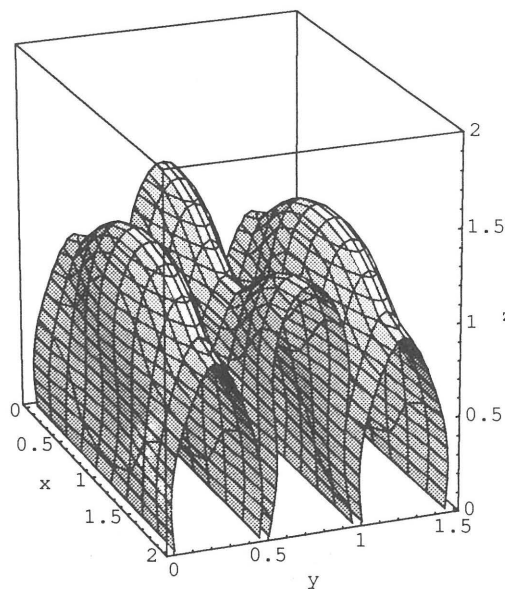

Fig.2: The iso-flux surfaces of the magnetic arcades which are modified by the undulating mode instability.