

§28. Quasi-Optical Antenna System for JIPPT-IIU

Kubo, S., Idei, H., Ohkubo, K., Watari, T., Toi, K.
Iwase, M. (Graduate University for Advanced Studies)

Electron cyclotron heating system for JIPPT-IIU is under construction. High power (400kW) microwave from the gyrotron with the frequency of 53.2 GHz used for the ECH experiment on CHS is connected to JIPPT-IIU by long distance corrugated waveguide transmission line between halls of CHS and JIPPT-IIU. A part of the quasi optical transmission line for CHS is modified to switch the transmitted power to couple to the corrugated waveguide. The transmitted power via corrugated waveguide is again converted to Gaussian beam to couple to the antenna system attached on the JIPPT-IIU. This antenna system is designed so that the focused Gaussian beam has a waist at the center of the vacuum vessel with the waist size of 20 mm. The cross sectional drawing of the antenna system is shown in Fig.1. Symmetric Gaussian beam with the waist at the

window with the waist size of 25 mm is weakly focused to be a wide beam at the final focusing mirror. The wide Gaussian beam is strongly focused by the final mirror to have an axisymmetric waist at the center of the vacuum vessel with the waist size of 20 mm in case of the axis heating. The design concept of the focusing mirrors is the same as that developed for the antenna system for CHS [1]. The final plane mirror can be steered to direct the beam from 0 to 45 degree in the poloidal cross section which covers upper half of the plasma cross section. Thus, the power deposition region can be controlled without changing the magnitude of the toroidal magnetic field.

This steering mirror has another capability to direct the beam toroidally within 15 degree from perpendicular to the magnetic field in both co and counter directions. This capability allows to do a electron cyclotron current drive experiment.

Reference

- 1) Kubo, S., et al., Fusion Engineering and Design 26 (1995)319.

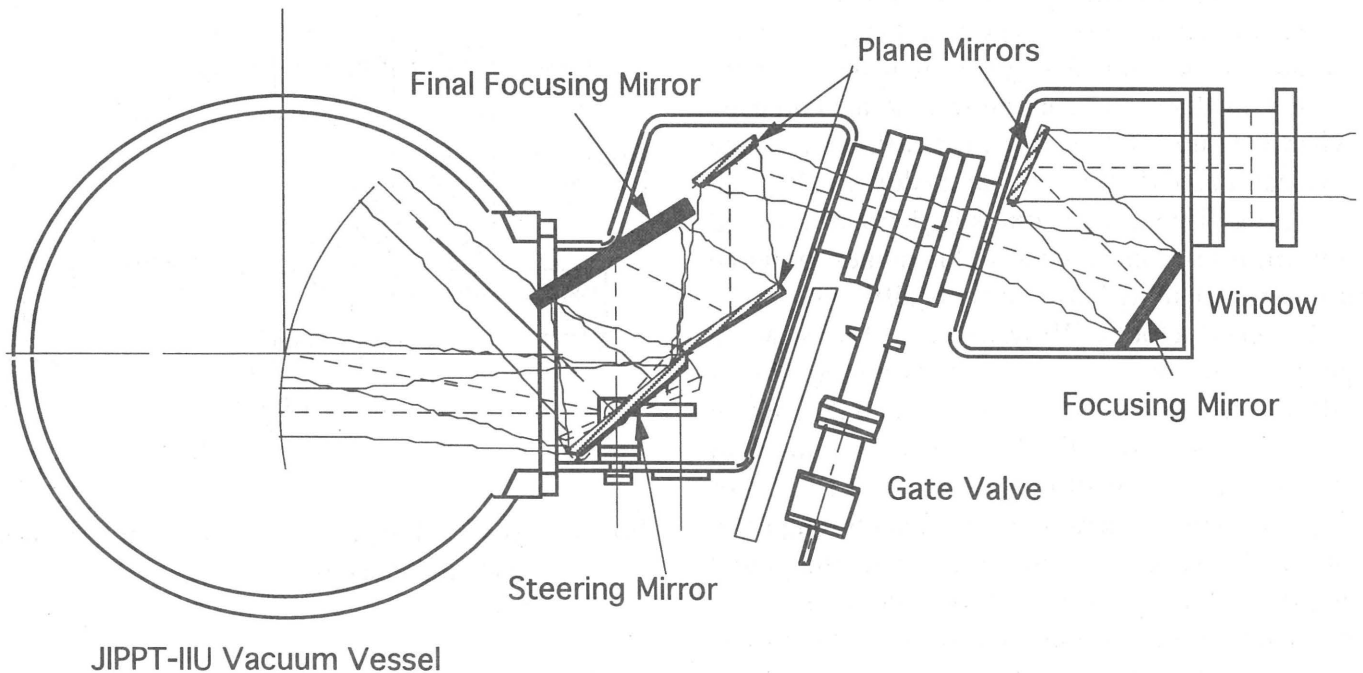

Fig. 1 The cross sectional view of the ECH antenna system for JIPPT-IIU