

§38. Local Island Divertor for CHS

Komori, A., Ohyabu, N., Sakakibara, S., Masuzaki, S., Morisaki, T., Suzuki, H., Yamada, H., Watanabe, K., Watanabe, T., Takahashi, C., Nishimura, K., Okamura, S., Matsuoka, K., Motojima, O., England, A.C. (ORNL)
 Lyon, J.F. (ORNL)
 Rome, J.A. (ORNL)

A local island divertor (LID) has been proposed for the edge plasma control of the Large Helical Device (LHD) [1]. The LID functions, however, have not been studied experimentally, so that experiments are intended to demonstrate the principle of the LID, using the Compact Helical System (CHS). All LID instruments required for the CHS were prepared at the end of this period.

The LID magnetic configuration, an $m/n=1/1$ island, is formed with 16 small coils located above and below the CHS. The LID experiments are performed with a toroidal magnetic field B of 1 T, a magnetic axis position R_{ax} of 97.4 cm, and a maximum island width of ~ 4 cm. The outward heat and particle fluxes crossing the island separatrix are designed to flow along the field lines to the back side of the island. Carbon target plates are placed there on a divertor head located at a toroidal position giving the maximum island width. The plates cross the island separatrix at a small angle. Thus the target plates and divertor head have almost the same shape as the island separatrix, which has a three dimensional curved surface. Since it is difficult to make the target plates and divertor head with the three dimensional curved surfaces, their surfaces are designed to be formed only with planes, as shown in Fig. 1.

The particles recycled on the target plates are pumped out by a cryosorption pump of 21,000 l/s pumping speed for H_2 . A closed divertor system is formed by the divertor head and pumping duct, as shown in Fig. 2. This is expected to achieve a high pumping efficiency which will be clarified by edge plasma measurements and pressure measurements with fast ion gauges. Reciprocating Langmuir probe, RI TV camera, and H-alpha measurements will also help determine the effectiveness of the LID.

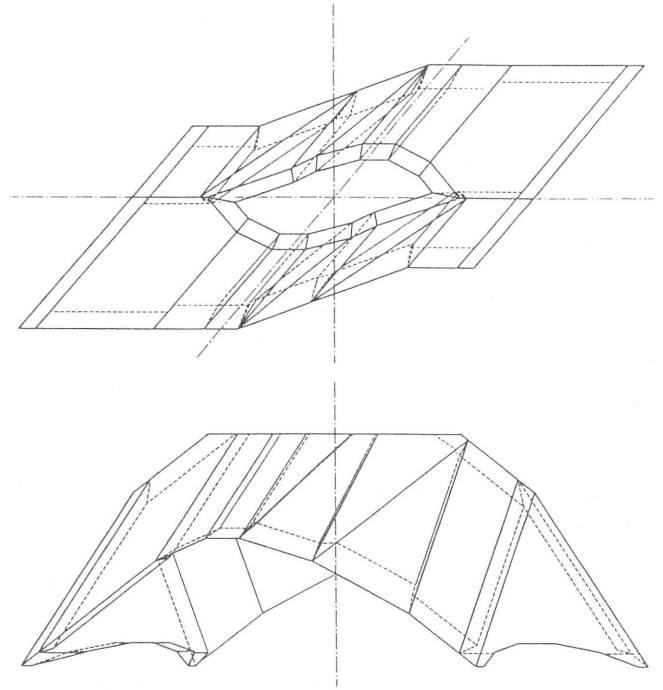

Fig. 1. A divertor head covered with carbon target plates.

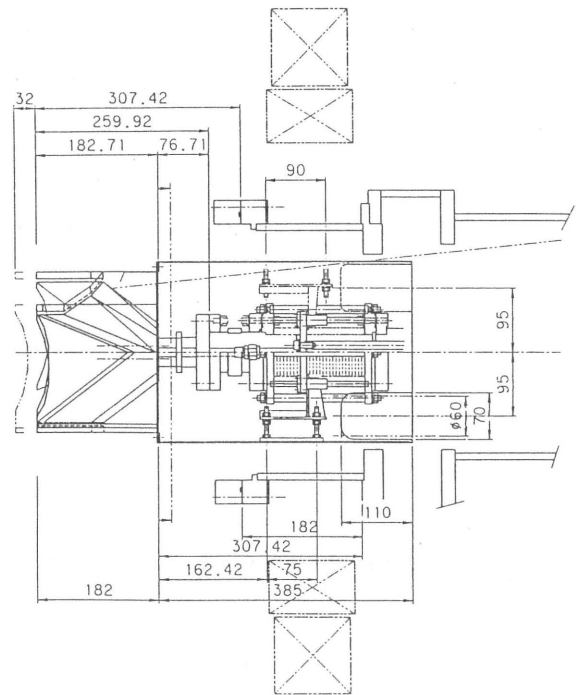

Fig. 2. A closed divertor system formed by a divertor head and a pumping duct.

References

- [1] Komori, A., et al., in *Plasma Physics and Controlled Nuclear Fusion Research 1994* (Proc. 15th Int. Conf. Seville, 1994), IAEA-CN-60/F-P-4.