

## §5. Development of Multi-channel Heterodyne Receiver for ECE Imaging and Application on LHD

Kogi, Y., Sakoda, T., Mase, A., Yokota, Y. (ASTEC Kyushu Univ.), Yamaguchi, S., Nagayama, Y., Kawahata, K.

An electron cyclotron emission (ECE) radiometer is an essential tool to investigate radial electron temperature profile in magnetically confined plasmas. In the ECE diagnostics, a receiver antenna detects the ECE from plasma. Since the frequency of the ECE is too high to process such as amplifying etc., it is common to introduce heterodyne detection which utilizes frequency mixers and local oscillators (LOs) to convert the signal frequency. After the frequency conversion, a band-pass filter bank with different pass-band, which corresponds to radial emission point, resolves the heterodyne signals. Then video detectors detect amplitude of these filtered signals which correspond to the electron temperature of the specific area. In the recent study, this diagnostics is progressed to not only one-dimensional resolved measurement but also two or three-dimensional measurement by utilizing a detecting antenna array. This study is performed to construct the IF system for the ECE imaging diagnostics. Fig. 1 (a) shows a block diagram of the IF system. It consists of a 3 stages of broad band amplifier, a low pass filter, a band pass filter bank, and video detectors. These functional components are realized on a Teflon substrate as shown in Fig. 1(b).

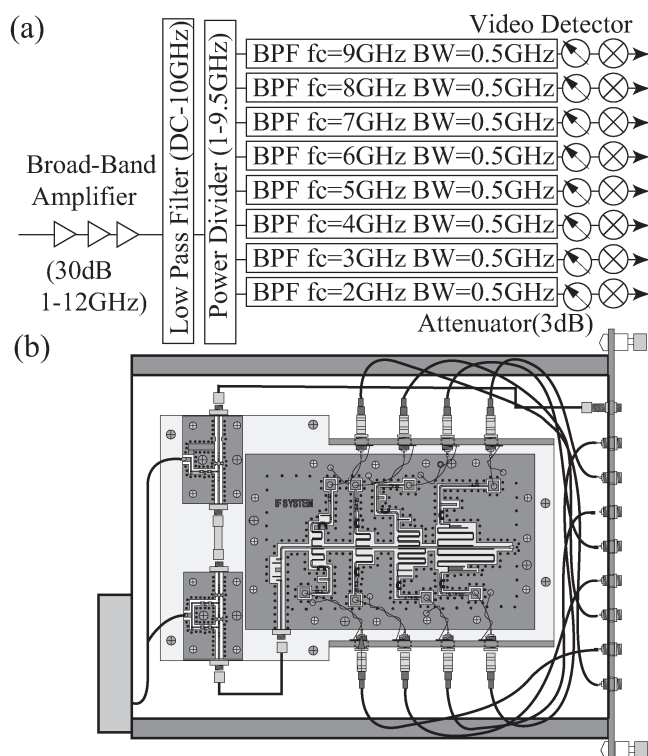

Fig. 1 The block diagram(a) and the illustration(b) of the IF system

We connect the IF system to an heterodyne output of the existent ECE radiometer system on LHD along with an additional frequency conversion module. This system accepts the second harmonics of the ECE with frequency from 110 to 160 GHz. The signal is mixed with LO (132 GHz). The frequency band of the heterodyne signal is upto 26 GHz. This signal is then further down converted by the additional conversion module. After the conversion, the frequency band of the IF signal is upto 10 GHz. Then the IF signal is resolved by the IF system. Figure 2 shows the time sequences of ECH (a) and ICRF (b) heating systems, and average electron density (c) measured by the FIR interferometer, and amplitude of the ECE (d) measured by the Michelson ECE spectrometer (broken curve) and the ECE radiometer (solid curve). Plasma is sustained over 10 seconds by the ECH. Frequency of the ECE measured by the radiometer is 134 GHz which is almost same to the measurement frequency of 134.42 GHz by the Michelson system. Although it is impossible to compare the amplitude variation before 6.5 seconds due to the influence of the ECH on the spectrometer, two traces are in good agreement with each other after 6.5 seconds. Since we have not calibrated the ECE radiometer system yet, the raw data measured by the radiometer is multiplied so as to fit the radiometer trace to the spectrometer's. From standard deviation of the AC noise measured by the radiometer, the total system noise of the radiometer is about 30eV. Although it has not been displayed in this report, time traces of other radiometer channels have similar shapes to the radiometer plot in Fig. 2 (c).

In the future, we plan to calibrate the IF system to achieve absolute temperature measurement. We also have to confirm reproducibility of the characteristics of IF systems.

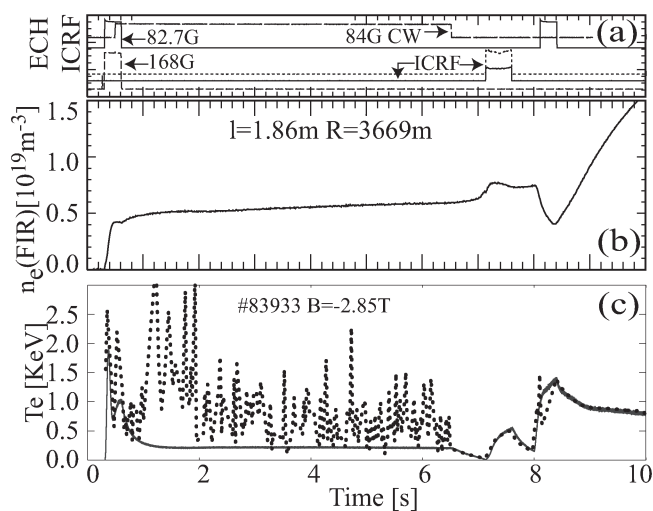

Fig. 2 Time sequence of the heating systems (a), electron density measured by the FIR interferometer(b), and time traces of electron temperature (c) measured by the radiometer (solid line) and Michelson spectrometer (dotted line).