

## §1. Development of an Access Control System for the LHD Experimental Hall

Kawano,T.,Inoue,N.,Sakuma,Y.,Uda,T.,Yamanishi,H.,Miyake,H.,Tanahashi,S., and Motojima,O.

With the construction of the large helical device(LHD), an access control system have been developed simultaneously. The access control system is originally a device keeping strict watch on an entrance all though the time. The systems found in most radiation facilities usually involve many functions, typically prevention of intrusion of a person without permission, daily record of entrance into and exit from a controlled area, administration of an amount of radioisotope, checking of radioactivity contamination, monitoring of personnel radiation exposure, and so forth. In the case of National Institute for Fusion Science(NIFS), the access control system for the LHD experimental hall was developed while being equipped with a function of interlock signal used in exchange with the LHD control system as a characteristic one.

The construction of the whole system and a set of interlock signals are graphically summarized in Fig.1, in which the system itself is composed of an access control computer, five entrance gates and eight shielding doors. And eight interlock signals available for their respective purposes are also found.

The access control computer is used to register information of each person into the access control system. The information contain a name, an identification (ID) card number, affiliation and so forth. The individual information may certainly be altered, revised and deleted also by using the computer. The computer is used likewise to send/accept the interlock signals to/from the LHD control system. The present situations of the interlock signals and the personnel access are shown in real time on the computer display, which is a furthermore important role.

The entrance gates are located at four places in the LHD experimental hall. At the inspection room(1) in Fig.1, two entrance gates are found because of frequent going in and out. The entrance gates are combined with the shielding doors at every place. All the shielding doors are compared to 2m-thick movable concrete walls. As shown in Fig.1, the LHD experimental hall has these shielding doors at eight positions. Three of them are the slide type moving from side to side and the other fives, the offset type moving back and forth. The former type of shielding doors are found at the three carriage entrances for large scale articles and the later type ones, at the entrance gates and the hall overview(in Fig.1). Each of the entrance gates has a turnstile with three arms and a pair of ID card readers on the entrance side and the

exit side. Being held a ID card in front of the surface of the card reader, the access control system checks the ID card number and unlock the turnstile if the number is identified. When a person enters or exits through the entrance gate, the access informations including the ID card number, a person's name, a gate number, date, time are recorded in the access control computer.

A set of interlock system is integrated into between the access control system and the LHD control system for the securement of safety operation of the LHD. Six signals of the set are properly sent as the occasion demands from the access control system to the LHD control system and the other two, in the opposite manner. The meanings and parts of the interlock signals are briefly shown in corresponding squares in Fig.1.

In March 1998, the operation of the access control system was started, and immediately the importance of establishment of the access control system with the function of interlock signal was practically reconfirmed. The access control is necessary to ensure safety for users' entering into or exiting from a controlled area and to eradicate careless mistakes. The access control system will certainly play important roles relating to the LHD control and the plasma experiments from the view point of protecting a person from not only a radiation field but a electro-magnetic field.

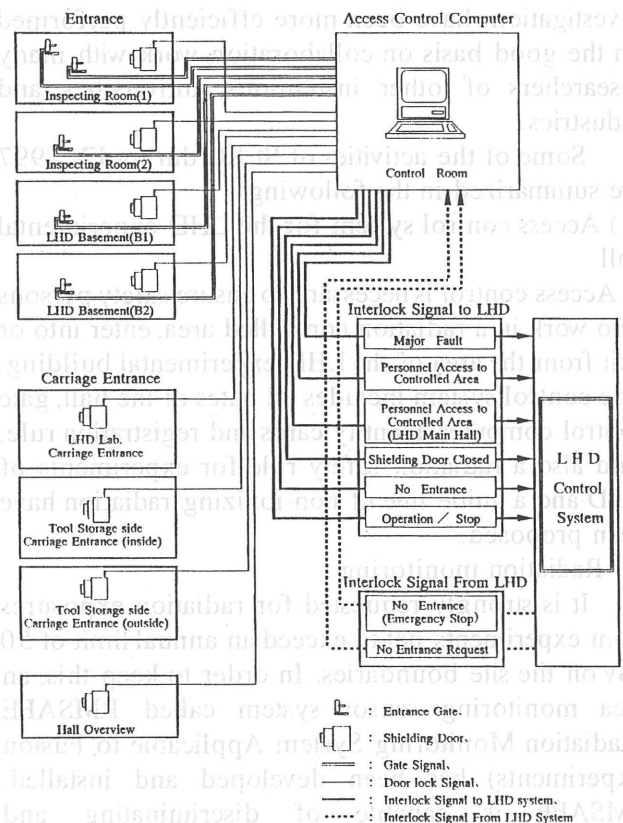

Fig.1 Access Control System and Interlock Signal