

§13. Development of the Electron Energy Distribution Function Measurement From Time-derivatives of the Electrostatic Probe Characteristics

Kado, S. (Kyoto Univ.),
Watanabe, S., Yamano, M., Iida, Y. (Univ. Tokyo),
Iida, K.

This work has been conducted as a part of the LHD Project Research Collaboration "Experimental verification of helium line spectroscopy models by intermachine and intermethod comparison".

Reaction rates adopted in the conventional collisional-radiative (CR) model [1] were calculated assuming the Maxwell distribution for the Electron Energy Distribution Function (EEDF):

$$\langle \sigma(v)v \rangle = \frac{2}{\sqrt{\pi} (kT_e)^{3/2}} \int_0^{\infty} \sigma(\varepsilon) \sqrt{\frac{2\varepsilon}{m_e}} \exp(-\varepsilon / kT_e) \sqrt{\varepsilon} d\varepsilon \quad (1)$$

where σ represents an arbitrary inelastic electron impact cross section, such as excitation, deexcitation or ionization, that depends on the electron velocity v , namely on its kinetic energy $\varepsilon = m_e v^2/2$, where m_e is the electron mass. T_e is the electron temperature and k is the Boltzmann constant.

In our previous preliminary study investigating the effect of EEDF on the He I CR model [2], either form of bimaxwellian F_B which has two temperature components in the ratio $\alpha : (1-\alpha)$, as:

$$F_B(\varepsilon) d\varepsilon = C \cdot \sqrt{\varepsilon} \cdot (\alpha e^{-\varepsilon/kT_{e,High}} + (1-\alpha) e^{-\varepsilon/kT_{e,Low}}) d\varepsilon, \quad (2)$$

or the Druyvesteyn function F_D characterized by the shaping parameter γ as:

$$F_D(\varepsilon) d\varepsilon = C \cdot \sqrt{\varepsilon} \cdot e^{-\varepsilon/kT_e} d\varepsilon, \quad (3)$$

where C is the normalization constant, was assumed.

We have implemented these functions as well as the arbitral one for the electron impact excitation and deexcitation rates in the CR-model [3,4], and found that some line intensity ratios can be modified to a significant degree as the parameters α or γ changes [2].

However, there are several difficulties in the accurate measurement of EEDF.

From the early stage of the plasma physics research, EEDF has been measured based on a Druyvesteyn method [5] that uses second derivative d^2I/dV^2 of the probe current with respect to probe potential. Although numerical differentiation is a simple and typical method, it amplifies digitized noise. AC superimposed method that superimposes small alternating voltage on sweep voltage is used to obtain d^2I/dV^2 with a high accuracy by analyzing second harmonics (2ω), but one has to prepare costly lock-in amplifier to detect harmonics. In addition, in order to reduce the terms equal to or higher than the fourth order component included in the 2ω component, alternating voltage of small amplitude has to be used, which further worsen the signal to noise ratio (SNR).

Therefore in this study, d^2I/dV^2 was obtained from the first and second derivative of the probe current in time domain which were measured simultaneously using a

differentiator circuit, as shown in the following equation [6]

$$\frac{d^2I(t)}{dV^2(t)} = \left(\frac{d^2I}{dV^2} \frac{dV}{dt} - \frac{dI}{dt} \frac{d^2V}{dt^2} \right) \left/ \left(\frac{dV}{dt} \right)^3 \right. \quad (4)$$

High frequency noise at the output point of the differentiator circuit was reduced by filter circuit. In order to optimize the frequency-dependent throughput, these circuits were designed using a circuit simulator based on frequency characteristics of the probe current. Moreover, non-linear frequency components of the circuits were band-limited by performing the FIR (Finite Impulse Response) filter to the obtained data [7].

In this configuration, EEDF was measured successfully in MAP-II divertor simulator in the University of Tokyo[8] with such probe bias as 10 Hz triangle wave superimposed by 10 kHz sinusoidal wave, as shown in Fig. 1. Further investigations as to the accuracy, hysteresis for the increasing/decreasing phases in the voltage sweeping, and the sensitivity of the results to the noise are underway.

- [1] T. Fujimoto, "plasma spectroscopy", Oxford Univ Pr. (2004).
- [2] R. Komatsu, bachelor thesis dissertation, Dept. Engineering. Univ. Tokyo (2010).
- [3] M. Goto, J. Quant. Spectrosc. Radiat. Transf. **76**, 331 (2003).
- [4] Y. Iida, S. Kado, A. Okamoto *et al.*, J. Plasma Fusion Res. SERIES, **7**, 123(2006).
- [5] M.J. Druyvesteyn, Z. Phys. **64**, 781 (1930).
- [6] K.F. Schoenberg, Rev. Sci. Instrum. **49**, 1377 (1978).
- [7] S. Watanabe, S. Kado, *et al.*, Meeting Abst. Phys. Soc. Jpn., 68th annual, Hiroshima, 26aEF-2 (2013).
- [8] S. Kado, Y. Iida, S. Kajita *et al.*, J. Plasma Fusion Res. **81**, 810 (2005).

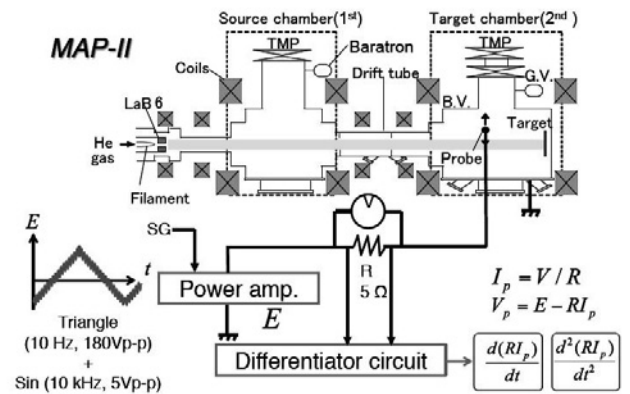

Fig. 1 Schematic diagram of the experimental setup.