

## §16. Basic Study on the Oxide Superconductors with a Large Current Capacity for Nuclear Fusion Reactors

Iwakuma, M. (Kyushu Univ.),  
Mito, T.

### 1. Introduction

In order to develop  $RE_1Ba_2Cu_3O_{7-x}$  (RE: Rare Earth, Y, Gd et al., REBCO) superconductors with a large current capacity and a low ac loss property for nuclear fusion reactors, we have introduced the configuration of parallel conductors as shown in Fig. 1. The constituent tapes of parallel conductors should be insulated and transposed so as to be equivalent in inductance with each other for the sake of uniform current distribution and low ac loss. We have investigated the ac loss and current sharing properties of transposed parallel conductors composed of REBCO superconducting tapes theoretically and experimentally. This year we studied how to transpose the REBCO tapes for a uniform current distribution in the case that a parallel conductor was wound into a solenoidal coil.

### 2. Current-sharing properties

For the analysis of current sharing among the constituent tapes in a transposed parallel conductor wound into a coil, the self and mutual inductances for every turn of the respective tapes were first calculated. Here let us consider the case that a 3-strand parallel conductor is wound into a 1-layer solenoid as shown in Fig. 2 for simplicity. The parallel conductor is represented as an equivalent circuit as shown in Fig. 3. Here each inductance corresponds to one turn of a tape. By summing the self and mutual inductances for the respective tapes up over the coil, the equivalent circuit shown in Fig. 3 is converted to the simple equivalent circuit as shown in Fig. 4.

Branch currents in the respective tapes can be calculated by the following circuit equation.

$$V = j\omega \begin{bmatrix} L_1 & M_{12} & M_{13} \\ M_{21} & L_2 & M_{23} \\ M_{31} & M_{32} & L_3 \end{bmatrix} I \quad (1)$$

where  $L_i$  is a self inductance of tape #  $i$  and  $M_{ij}$  is a mutual inductance between tape #  $i$  and tape #  $j$ ,  $\omega$  is equal to  $2\pi f$ ,  $f$  is frequency,  $I$  is a matrix of branch current,  $V$  is a voltage of an AC power supply.

In the case that a 3-strand parallel conductor is wound into a 1-layer solenoid, the optimum

transposition points are the positions at which the coil is divided into three equal parts in the direction of height. We investigated the optimum transposition points for various cases.

This work was also supported in part by New Energy and Industrial Technology Development Organization (NEDO) as Technological Development of Yttrium-based Superconducting Power Equipment.

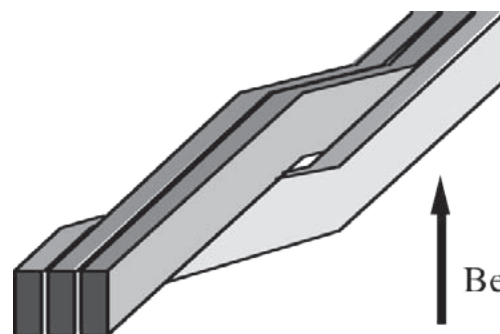

Fig. 1 Schematic illustration of the transposition in the case of a 3-strand parallel conductor.

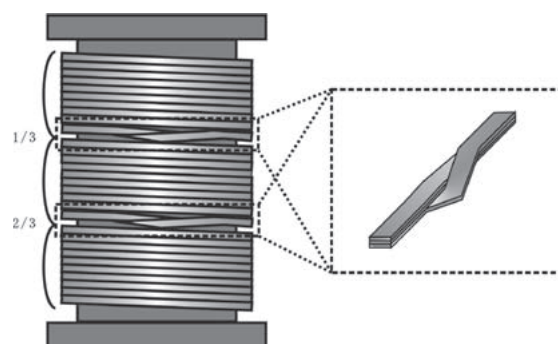

Fig. 2 Schematic illustration of a 3-strand parallel conductor wound into a 1-layer solenoid. The tapes are transposed at the indicated two points so as to be arranged as ①②③ in the upper part, ③①② in the central part and ②③① in the lower part.

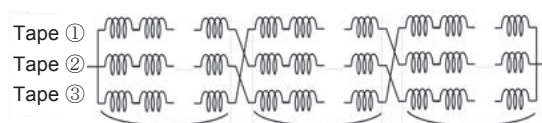

Fig. 3 Equivalent circuit of a 3-strand parallel conductor. Each inductance represents one turn of a tape.

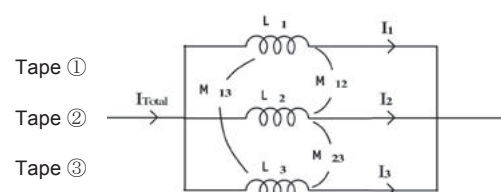

Fig. 5 Simple equivalent circuit of a 3-strand parallel conductor.