

§ 12. Study on Helically Trapped Energetic Ion Losses in Compact Helical System

Isobe, M., Darrow, D.S. (PPPL), Yoshimura, Y., Nagaoka, K., Matsushita, H. (Nagoya Univ.), Okamura, S.

One of potential issues in heliotron or torsatron plasmas is the confinement of energetic ions because of a lack of symmetry of the system. In order to investigate confinement and/or loss core structure of energetic ions from an experimental approach, a diagnostic neutral beam (DNB) has been installed as a test particle source on CHS. The beam line is on the equatorial plane and its injection angle can be varied from co- to counter-direction. In this experiment, DNB is injected into ECRH plasmas. Lost helically trapped ions are detected by use of a scintillator-based fast ion probe, providing both information of pitch angle and gyroradius simultaneously. This probe is installed at small major radius (R) side since helically trapped ions are theoretically predicted to be lost at small R side of CHS. 1) We have observed bright, localized light spots on the scintillator screen at $B_t/R_{ax} = 0.88T/0.921m$ when the injection angle of DNB is in a particular range of $-23 \sim -26$ degrees and the angle of -25 degrees gives the highest loss rate to probe (see Fig.2). Here, "-" means counter-injection of beams and the angle of 0 corresponds to perpendicular injection. Bright spots due to impact of lost fast ions appear around pitch angle of 60-70 degrees. When DNB is coinjected, no intense loss signals have been so far observed. Orbit analysis will be made to verify whether experimental observation can be explained by the ripple transport. In regard to neutral beam (NB)-heated plasmas, MHD effects on beam ion transport are also of interest. However, mode-induced loss of heating beam ion has not seen yet by the probe on the small R side although it has been clearly observed during co-injected NB heating by the probe on the large R side. 2-3)

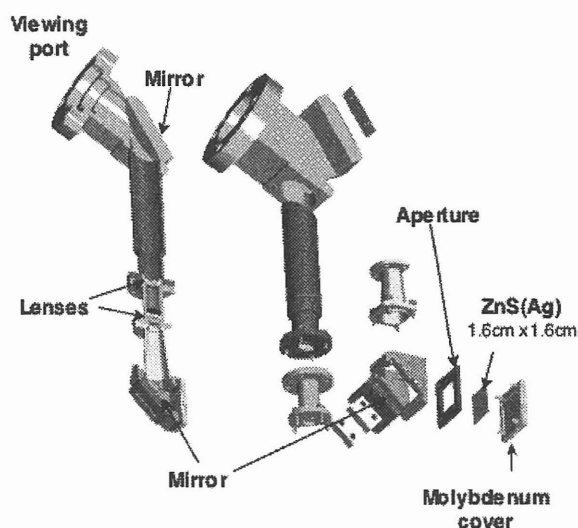

Fig. 1. Three-dimensional schematic drawing of a lost fast ion probe installed at small R side. 1)

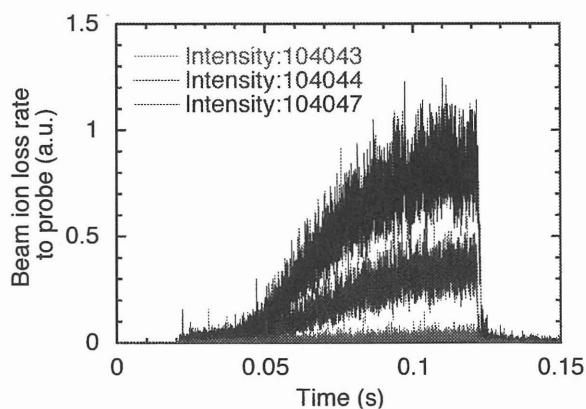

Fig. 2. Loss rate of escaping helically trapped fast ion to probe in different injection angle of diagnostic neutral beam.

References

- 1) Isobe, M. *et al.*, Rev. Sci. Instrum. **74**, (2003)1739.
- 2) Kondo, T. *et al.*, Nuclear Fusion **40**, (2000)1575.
- 3) Toi, K. *et al.*, Nuclear Fusion **39**, (1999)1929.