

## §11. Power System for Fusion Reactor Including Auxiliary Devices with Various Requirements for Supplied Power Quality

Ise, T., Miura, Y., Segi, H. (Osaka Univ.), Chikaraishi, H.

It is supposed that a nuclear fusion generation plant will include various auxiliary devices. For example, in the case of a magnetic confinement nuclear fusion reactor, power supplies and helium refrigerators for superconducting coils, plasma heating devices, vacuum pumps, control and measurement instruments will be included in the system. These devices require various power qualities, that is, some devices require high quality power without voltage sags and interruptions, some devices require high quality power without voltage sags, other devices do not require such high quality power. Some devices such as plasma heating devices may cause disturbances to power grid. In this study, the power system in a nuclear fusion generation plant is treated by the concept of multi-quality power supply or Quality Control Center (QCC), and the power system suitable for various kinds of loads is studied. That is, the power system which can continuously supply power for important devices in the plant without voltage sag and/or interruption and causes no disturbance to the power grid due to operation of the plant.

In the F.Y.2007, simulation studies of the multi-quality power supply system proposed in F.Y.2006 have been carried out. The simulation model is shown in Fig.1, which is for high quality B1 supply system. The single line circuit is shown in Fig.2. Simulation result is shown in Fig.3. At time  $t=0.44s$ , a fault is occurred at the point F in Fig.2 by turning on the switch SW1, resulting in voltage sag of the receiving voltage at point F with the 75 % of nominal voltage. After detection of this voltage sag, compensating voltage  $V_C$  is calculated in the controller, and the voltage is applied across the series transformer, then voltage sag is avoided at the load voltage  $V_L$ . At time  $t=0.46s$ , the breaker SW2 is turned off in order to cause an interruption. In spite of this situation, load power can be continuously supplied through the parallel converter. As shown in this simulation, load voltage  $V_L$  keeps constant voltage even in the cases of voltage sag and interruption.

The magnetic confinement nuclear fusion reactor includes load apparatuses which require various kinds of power quality in the concentrated area of the power plant. As a result, application of multi-quality power system is very suitable to the plant. The power plant can continue to operate even in the case of voltage sag and interruption and stable operation can be performed. Simultaneously, the energy storage devices in the power system can help to reduce power disturbances due to starting and stopping the

plant and operation of heating devices of plasma. As a result, the nuclear power plant is not only affected by the power system disturbances but also does not give disturbances to power systems.

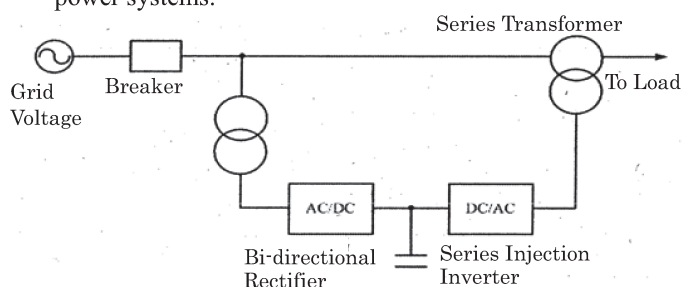

Fig.1. Configuration of the of High Quality B1 Supply System.

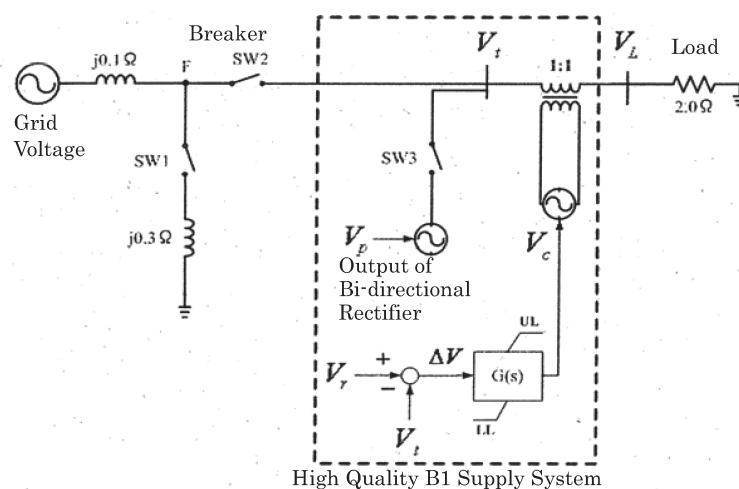

Fig.2. Simulation Model of High Quality B1 Supply System.

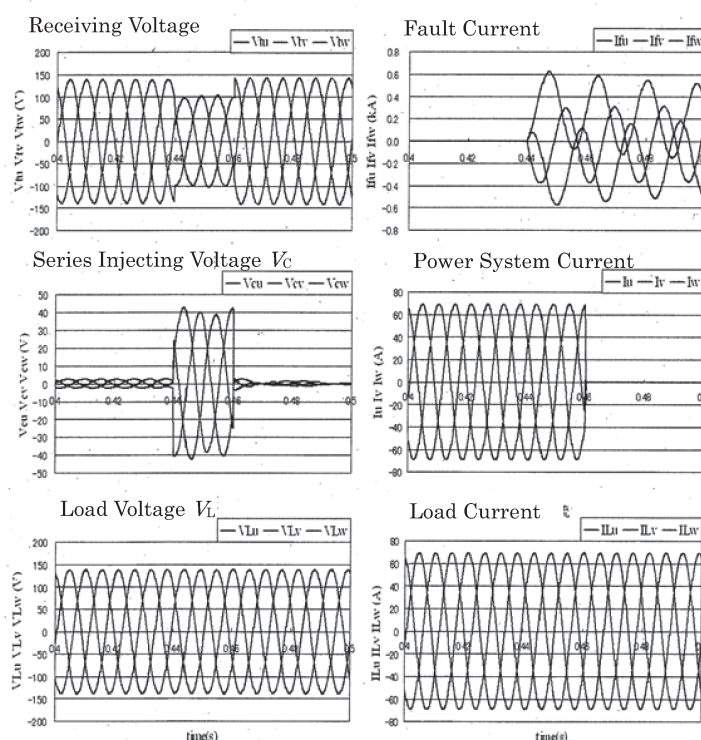

Fig.3. Simulation Result of High Quality B1 Supply System.